

US00RE46407E

(19) **United States**  
(12) **Reissued Patent**  
**MacKinnon**

(10) **Patent Number: US RE46,407 E**  
(45) **Date of Reissued Patent: May 23, 2017**

(54) **ENGINEERED PUSH UP INSERT**

(56) **References Cited**

(71) Applicant: **Runberg, Incorporated**, Spring Lake, NJ (US)

U.S. PATENT DOCUMENTS

(72) Inventor: **Debra MacKinnon**, Spring Lake, NJ (US)

2,697,228	A *	12/1954	Orr	450/57
2,817,842	A	12/1957	Block et al.	
2,834,352	A *	5/1958	Ullian	450/57
3,257,951	A *	6/1966	Espenschied et al.	92/140
3,384,091	A *	5/1968	Block	450/54
3,814,107	A *	6/1974	Greenblatt et al.	450/56
4,992,074	A *	2/1991	Diaz	450/81
6,042,608	A *	3/2000	Ishikawa et al.	623/7
6,101,630	A	8/2000	Lee	
6,231,423	B1	5/2001	Deal et al.	

(73) Assignee: **Runberg Incorporated**, Spring Lake, NJ (US)

(21) Appl. No.: **14/851,822**

(22) Filed: **Sep. 11, 2015**

(Continued)

**Related U.S. Patent Documents**

Reissue of:

(64) Patent No.: **8,216,021**  
Issued: **Jul. 10, 2012**  
Appl. No.: **12/461,116**  
Filed: **Jul. 31, 2009**

U.S. Applications:

(63) Continuation of application No. 14/327,362, filed on Jul. 9, 2014, now Pat. No. Re. 45,838, which is an application for the reissue of Pat. No. 8,216,021.

(60) Provisional application No. 61/085,335, filed on Jul. 31, 2008.

(51) **Int. Cl.**  
*A41C 3/00* (2006.01)  
*A41C 3/10* (2006.01)  
*A41C 3/14* (2006.01)

(52) **U.S. Cl.**  
CPC ..... *A41C 3/10* (2013.01); *A41C 3/144* (2013.01)

(58) **Field of Classification Search**  
CPC .... *A41C 3/10*; *A41C 3/12*; *A41C 3/14*; *A41C 3/144*; *A41C 3/146*  
USPC ..... 450/36-39, 54-58, 1; 2/267, 268; 623/7, 623/8

See application file for complete search history.

**OTHER PUBLICATIONS**

Definition of silicone, www.dictionary.com, May 2015.

*Primary Examiner* — Patricia Engle  
(74) *Attorney, Agent, or Firm* — Oblon, McClelland, Maier & Neustadt, L.L.P.

(57) **ABSTRACT**

Kidney-shaped push up insert including first lobe and second lobe is provided. Notch is formed in top side between first lobe and second lobe. Insert has depression formed adjacent top side extending towards notch. Second main surface opposes first main surface. Second main surface is substantially smooth arcuate-shaped surface. First lobe has narrower width between top side and bottom side than second lobe, and second lobe is thicker between first main surface and second main surface than first lobe. Ratio of maximum thickness between first main surface and second main surface to maximum length between opposing ends of first lobe and second lobe is less than about 9 and/or ratio of depth of notch from a straight line connecting first lobe and second lobe along top side of insert to width of insert from top side to bottom side at depth of notch is less than about 4.

**8 Claims, 21 Drawing Sheets**

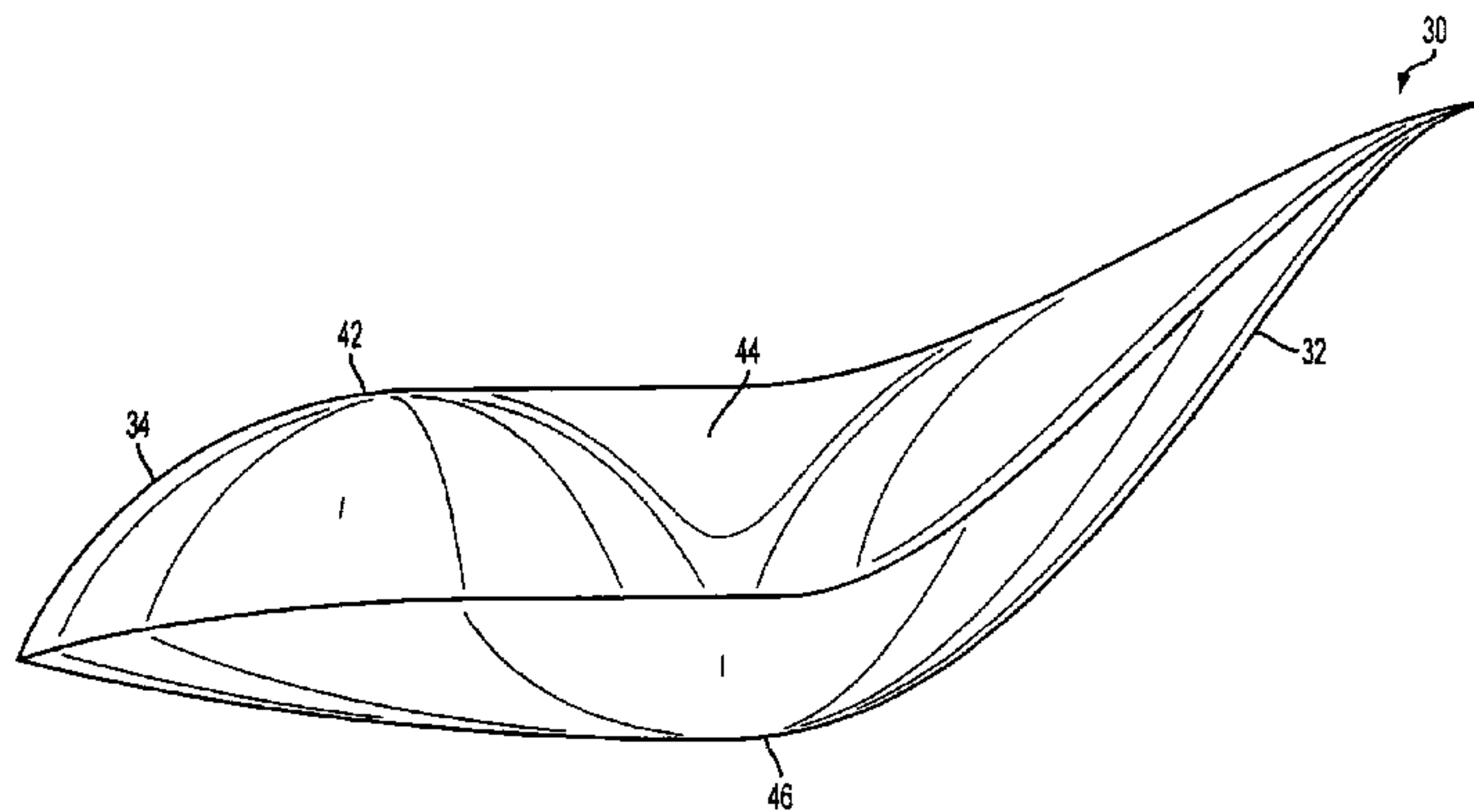
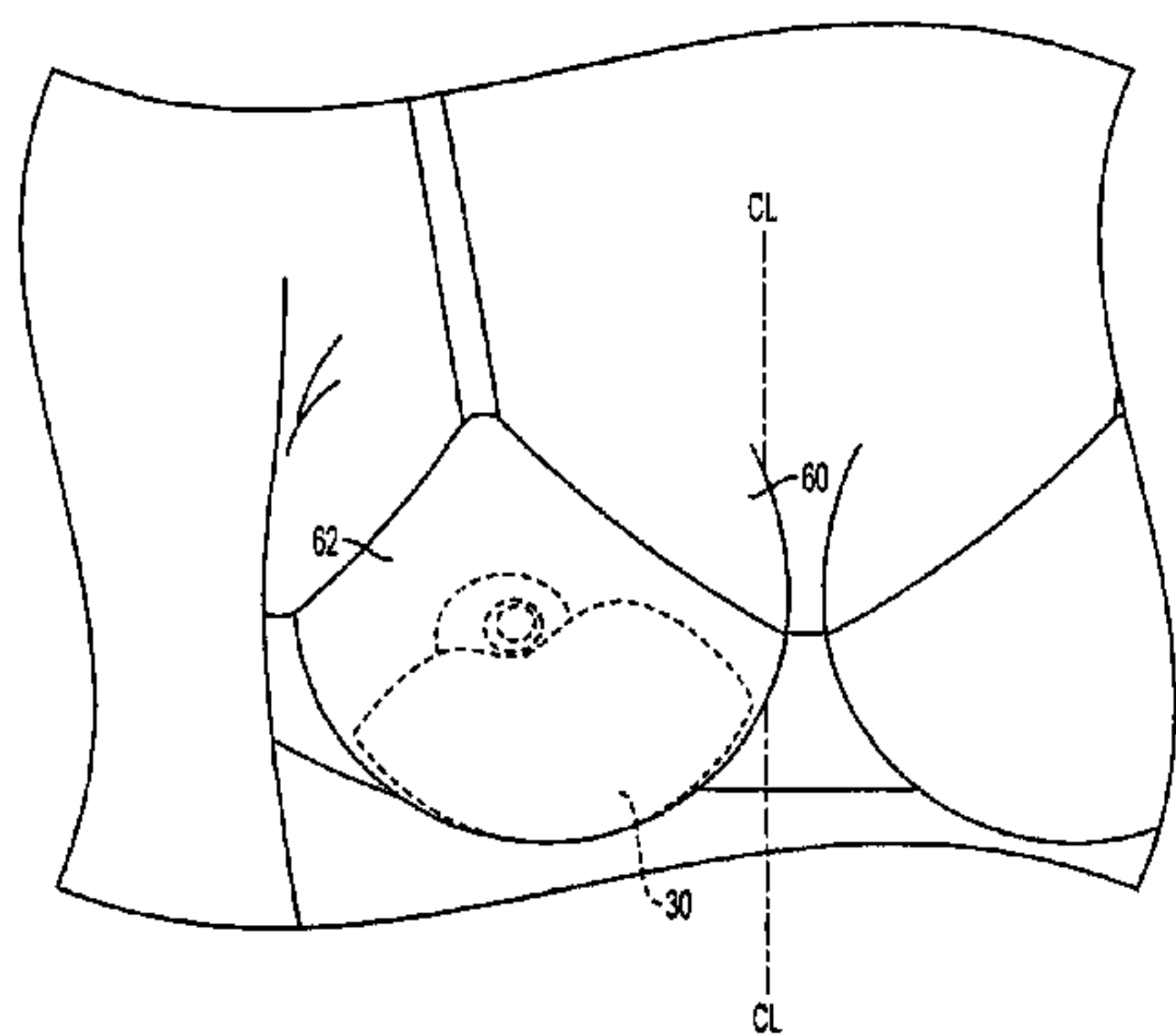

(56)

**References Cited**

U.S. PATENT DOCUMENTS

6,296,545	B1	10/2001	Chen	
6,443,806	B1 *	9/2002	Fang .....	450/57
6,544,100	B1 *	4/2003	Nadsady .....	A41C 3/144
				450/38
7,163,433	B2 *	1/2007	Chou .....	450/81
7,628,811	B1	12/2009	Gaskill	
D655,476	S	3/2012	Naughton et al.	

\* cited by examiner

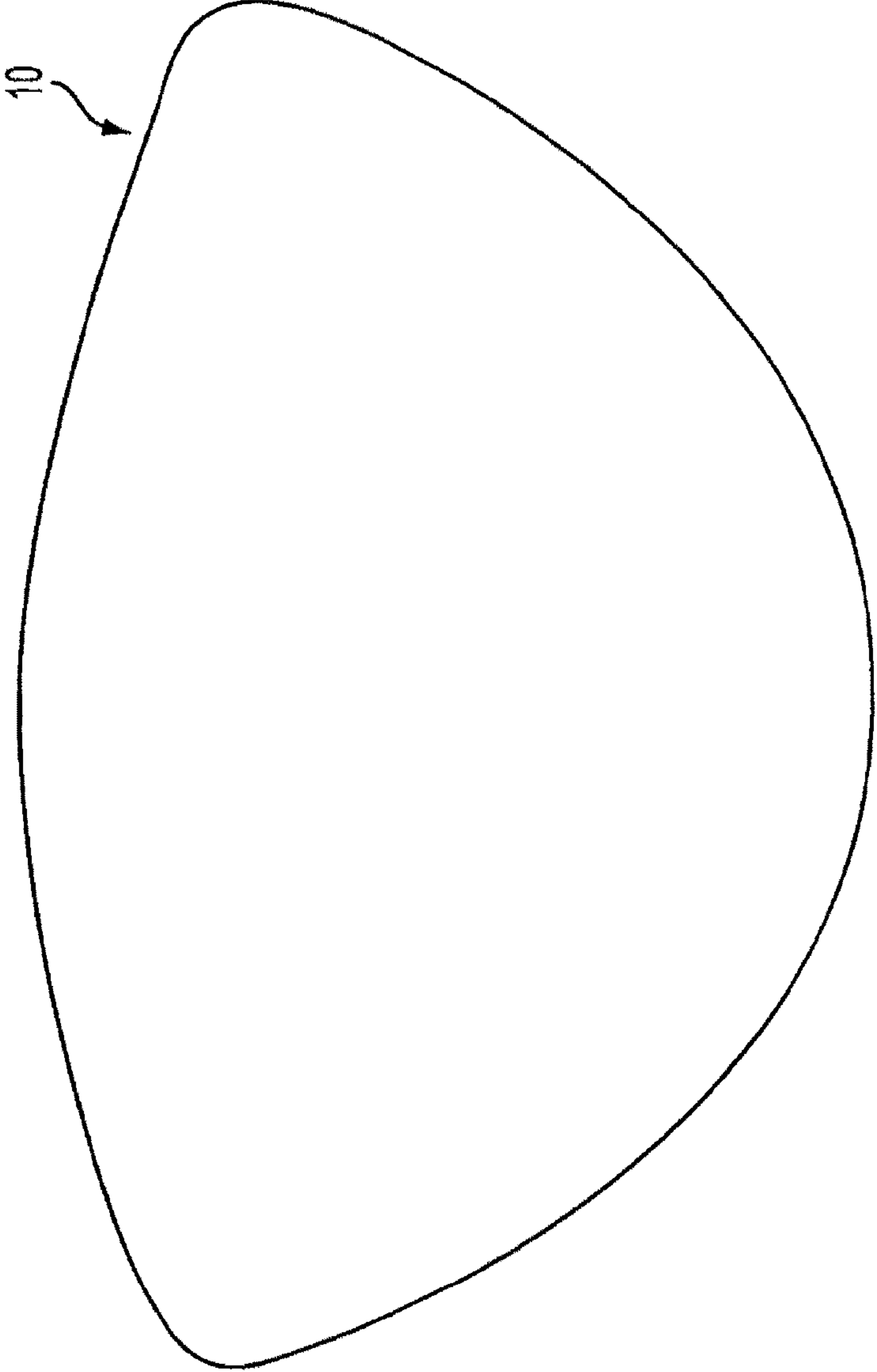

FIG. 1  
PRIOR ART

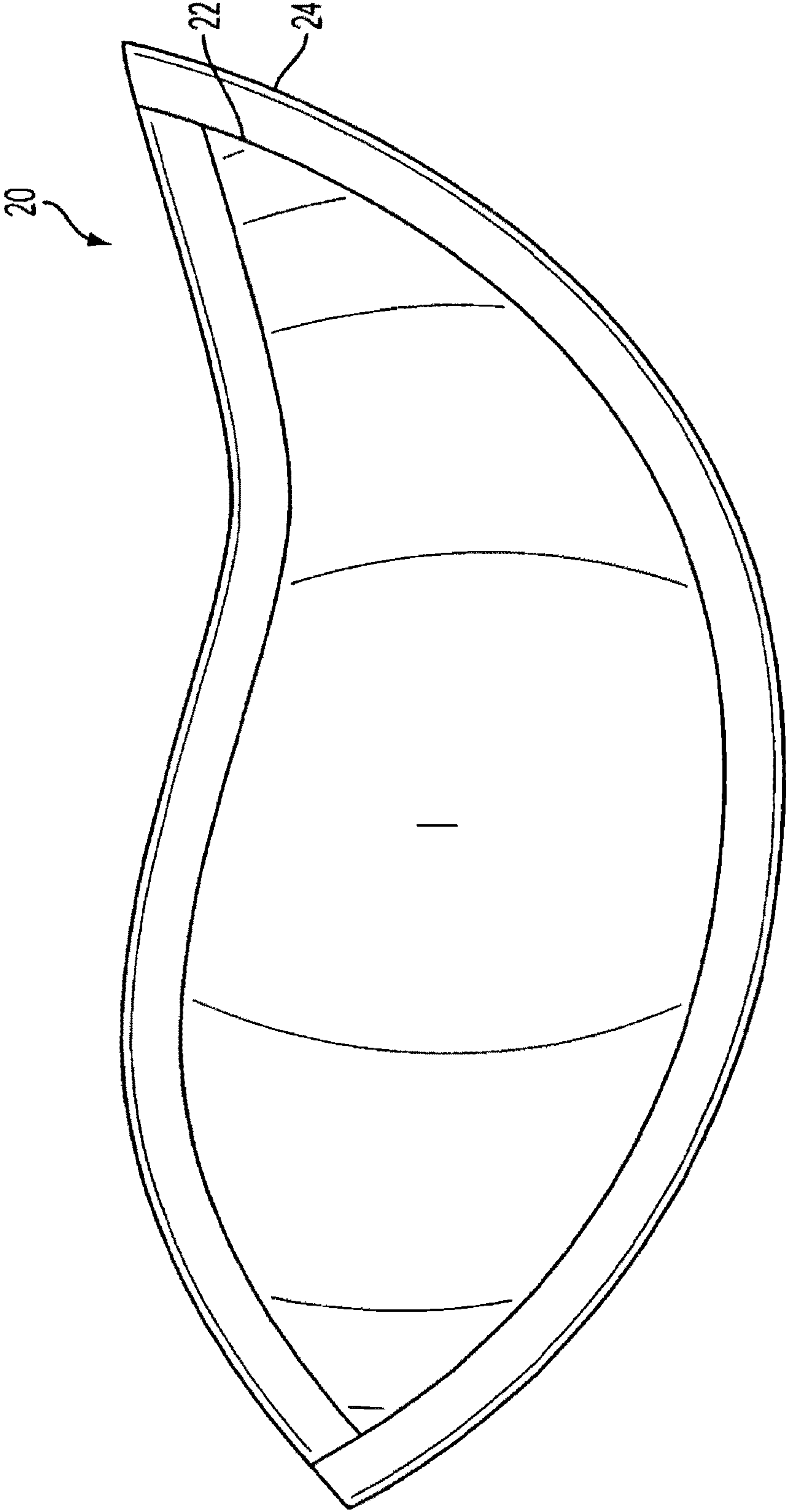

FIG. 2  
PRIOR ART

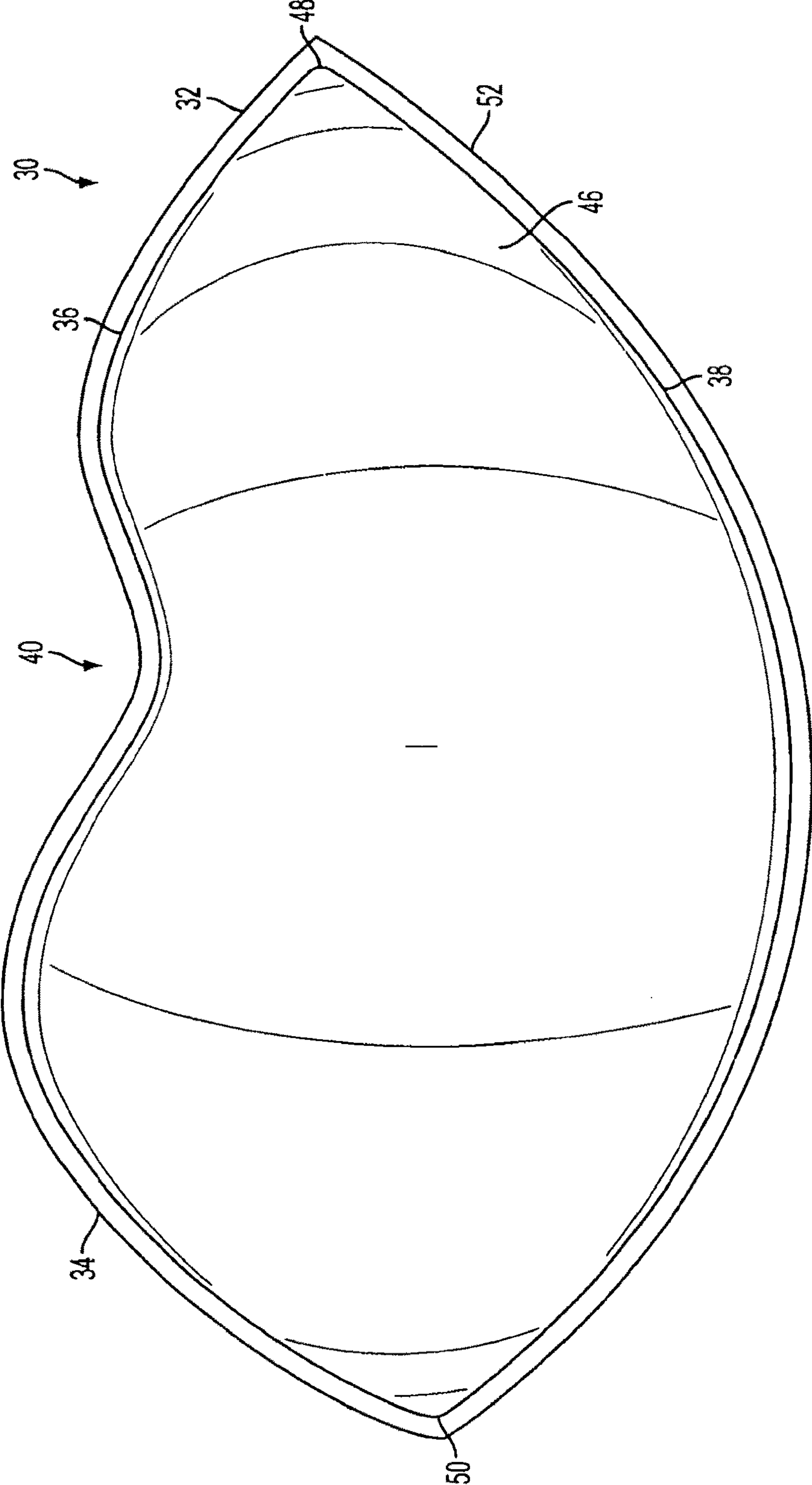

FIG. 3



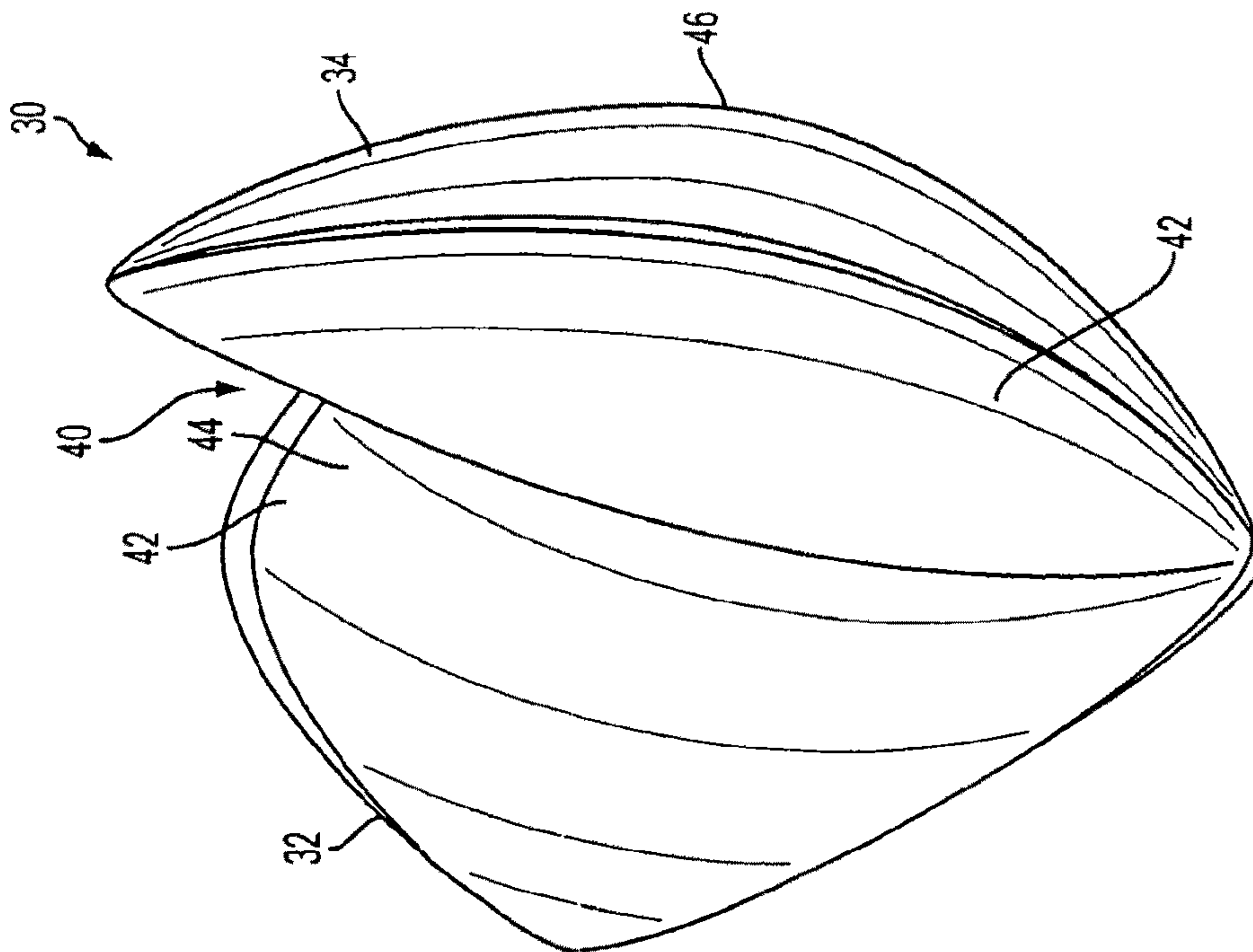

FIG. 4

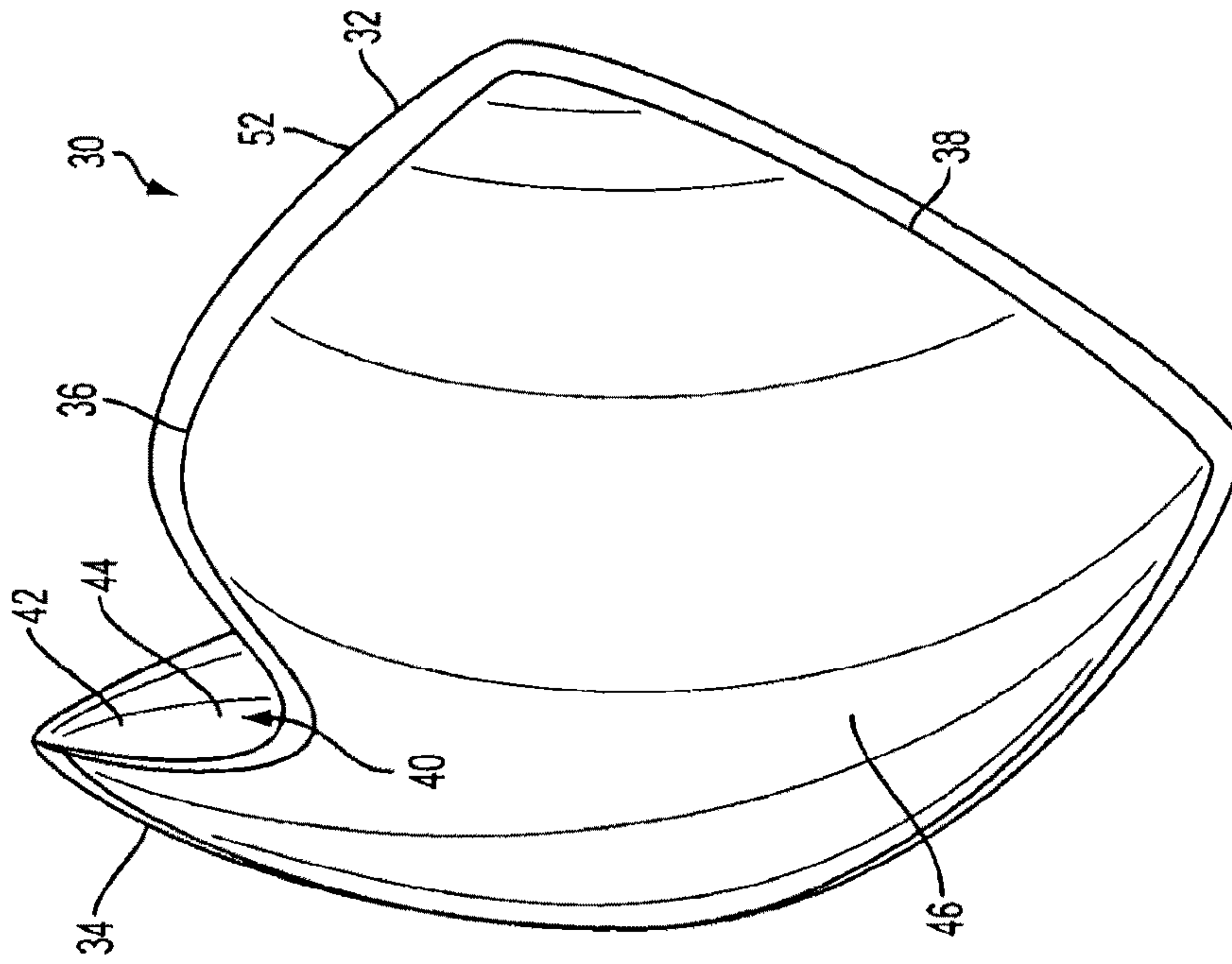

FIG. 5

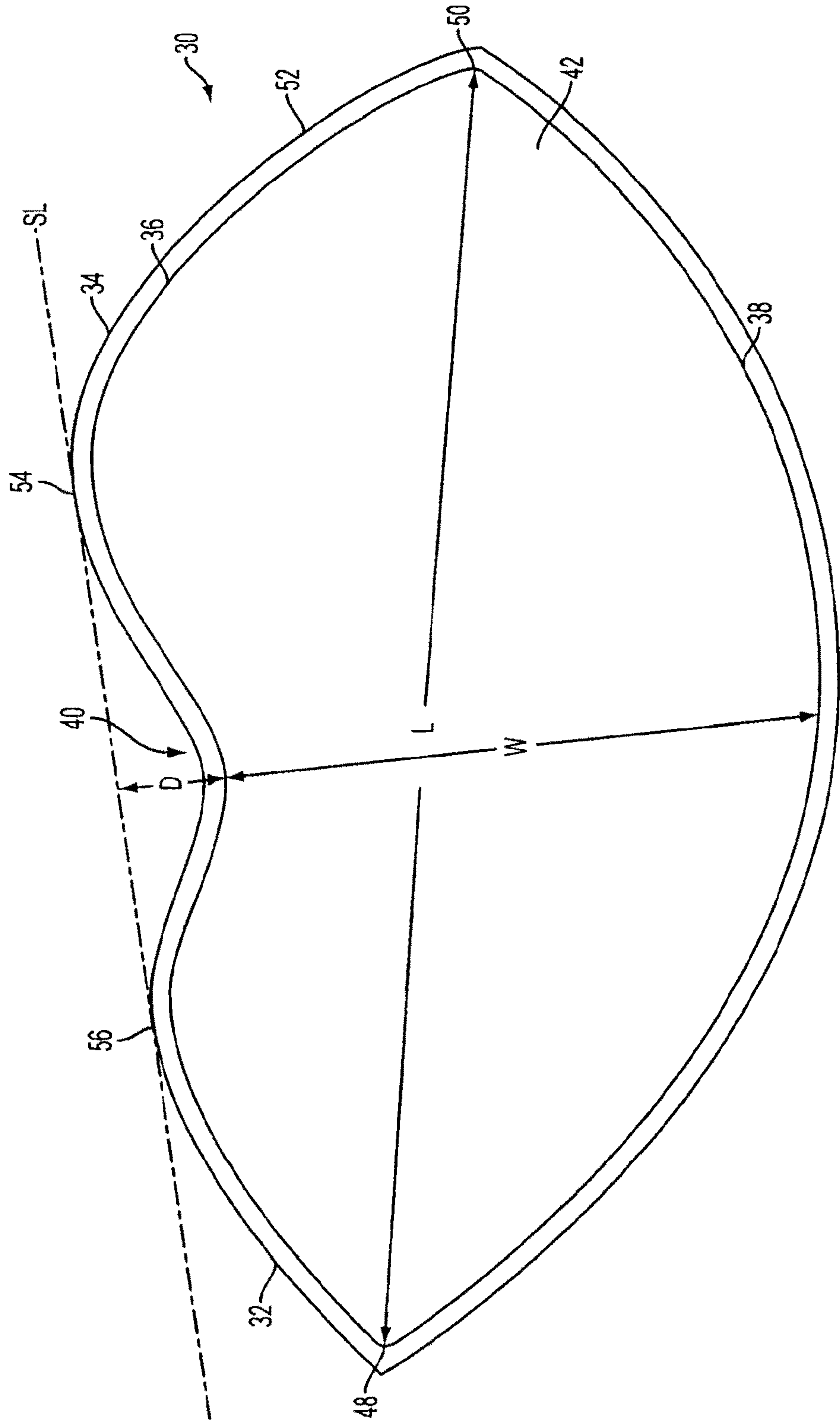

FIG. 6

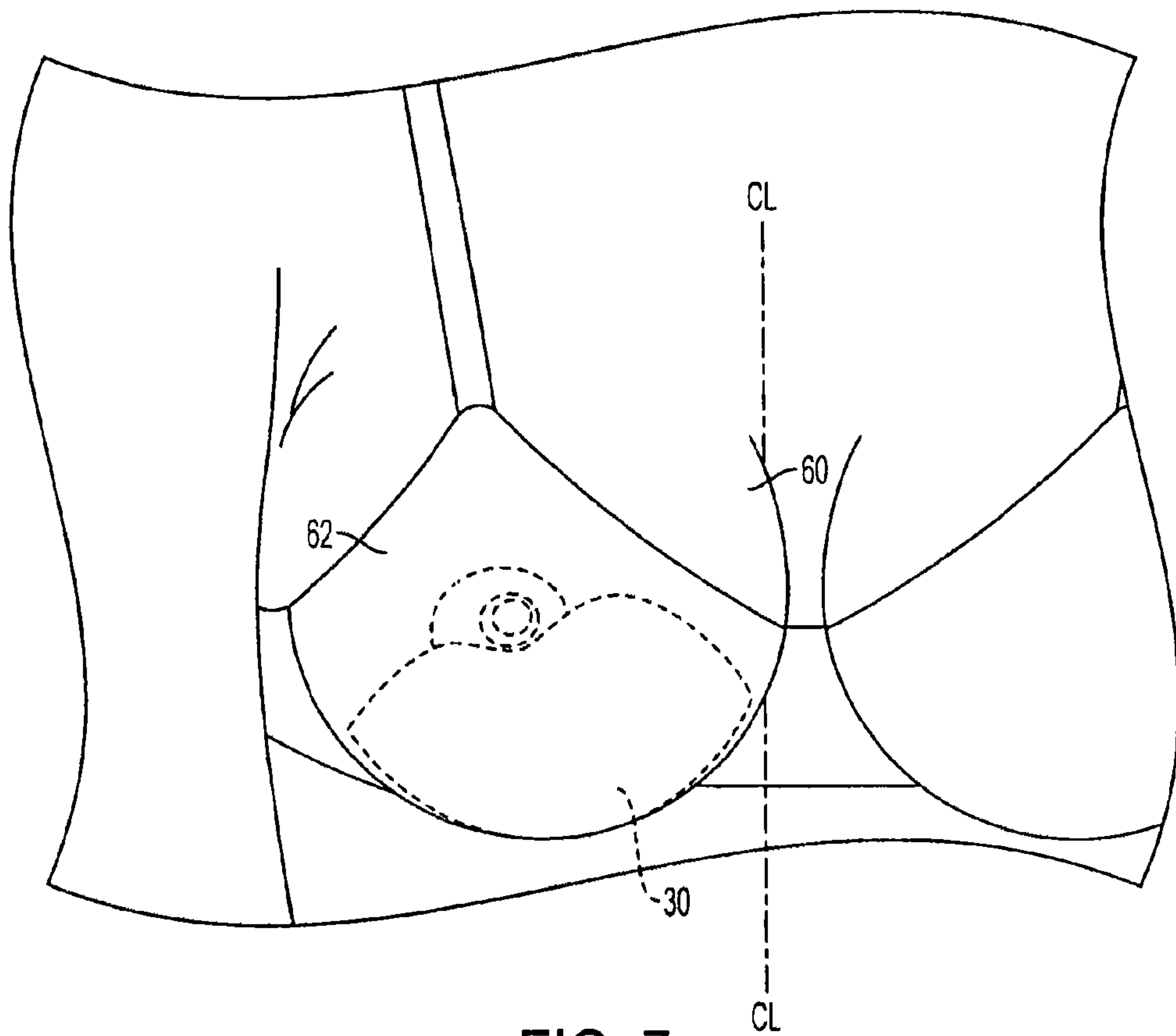

FIG. 7



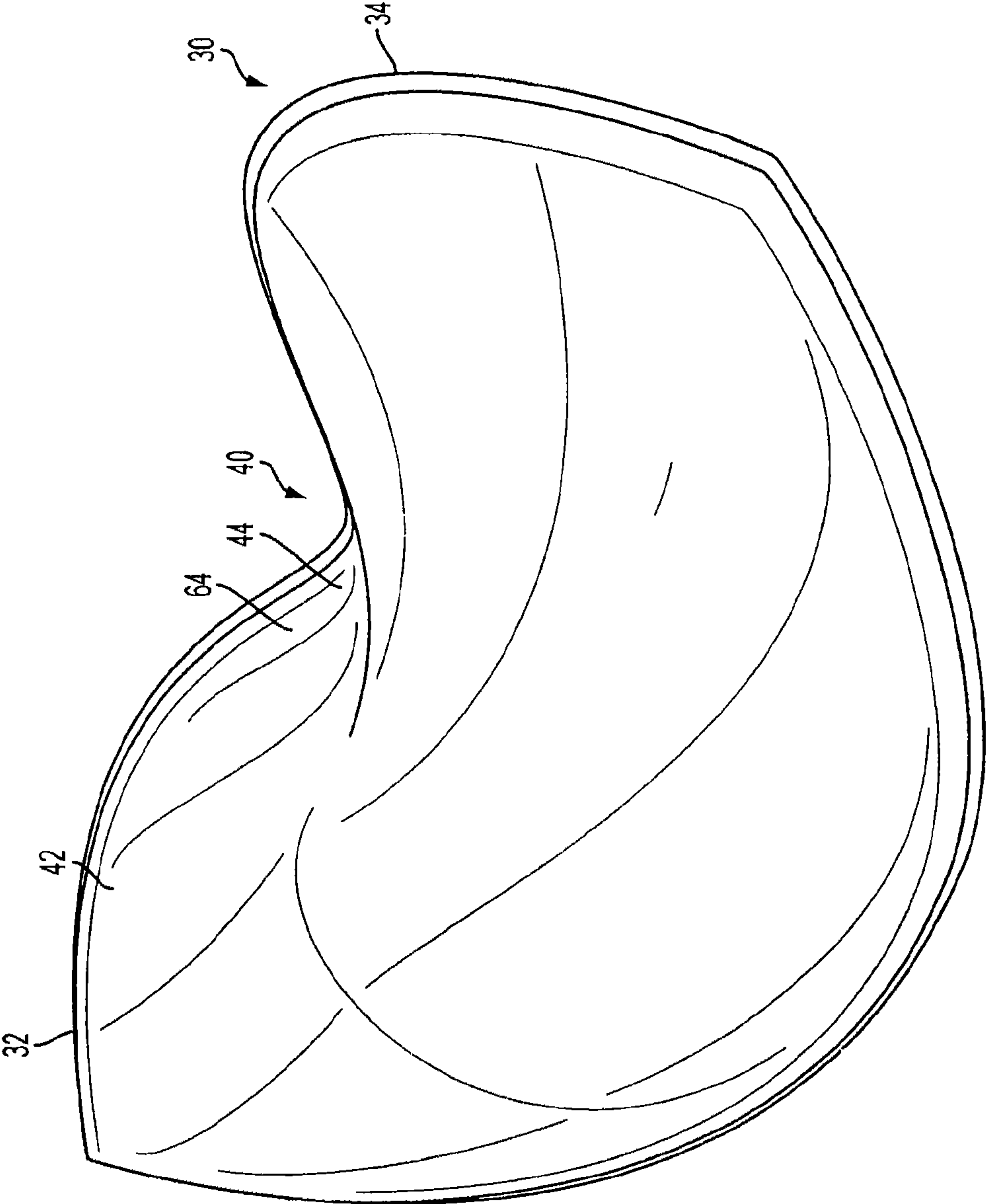

FIG. 8

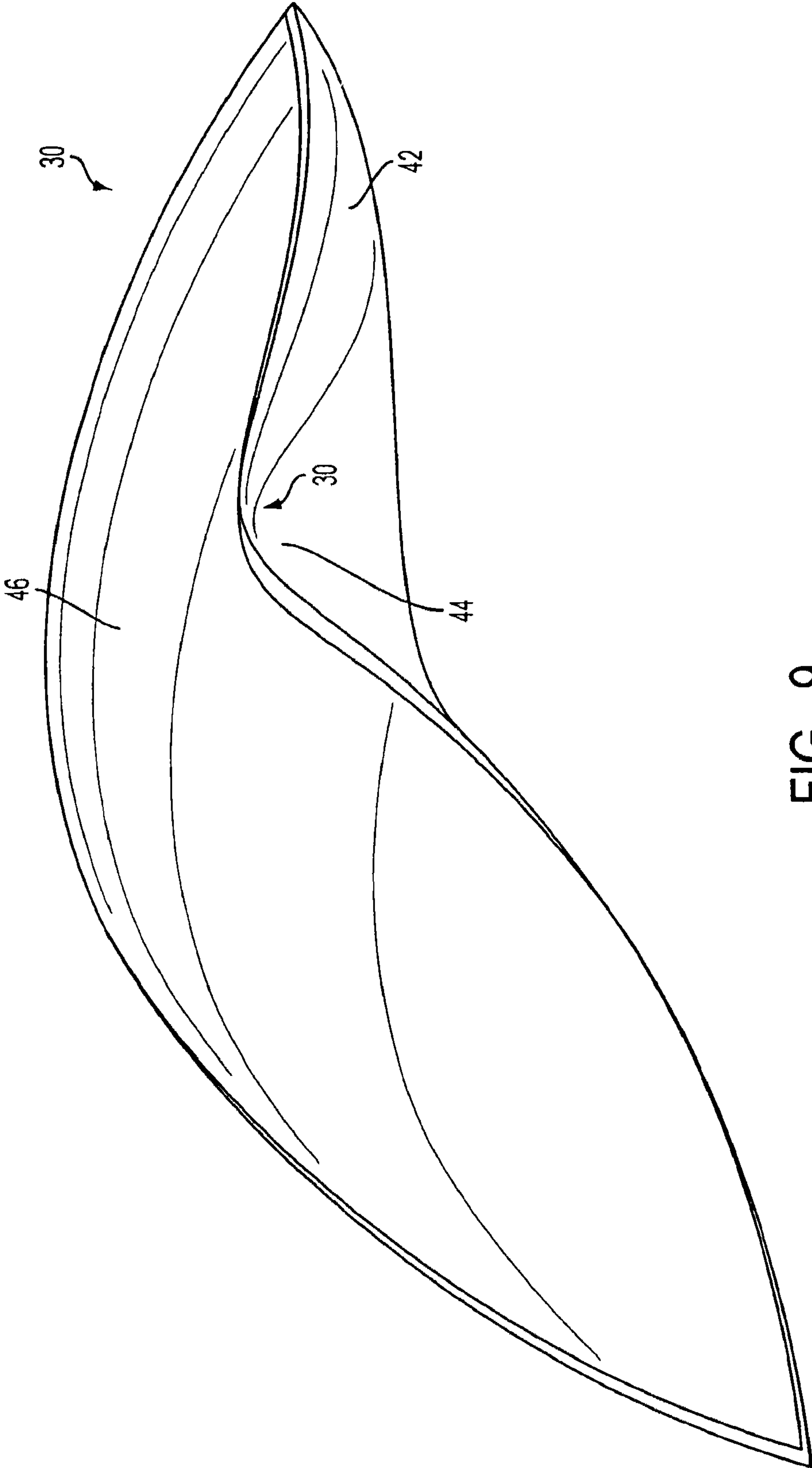

FIG. 9

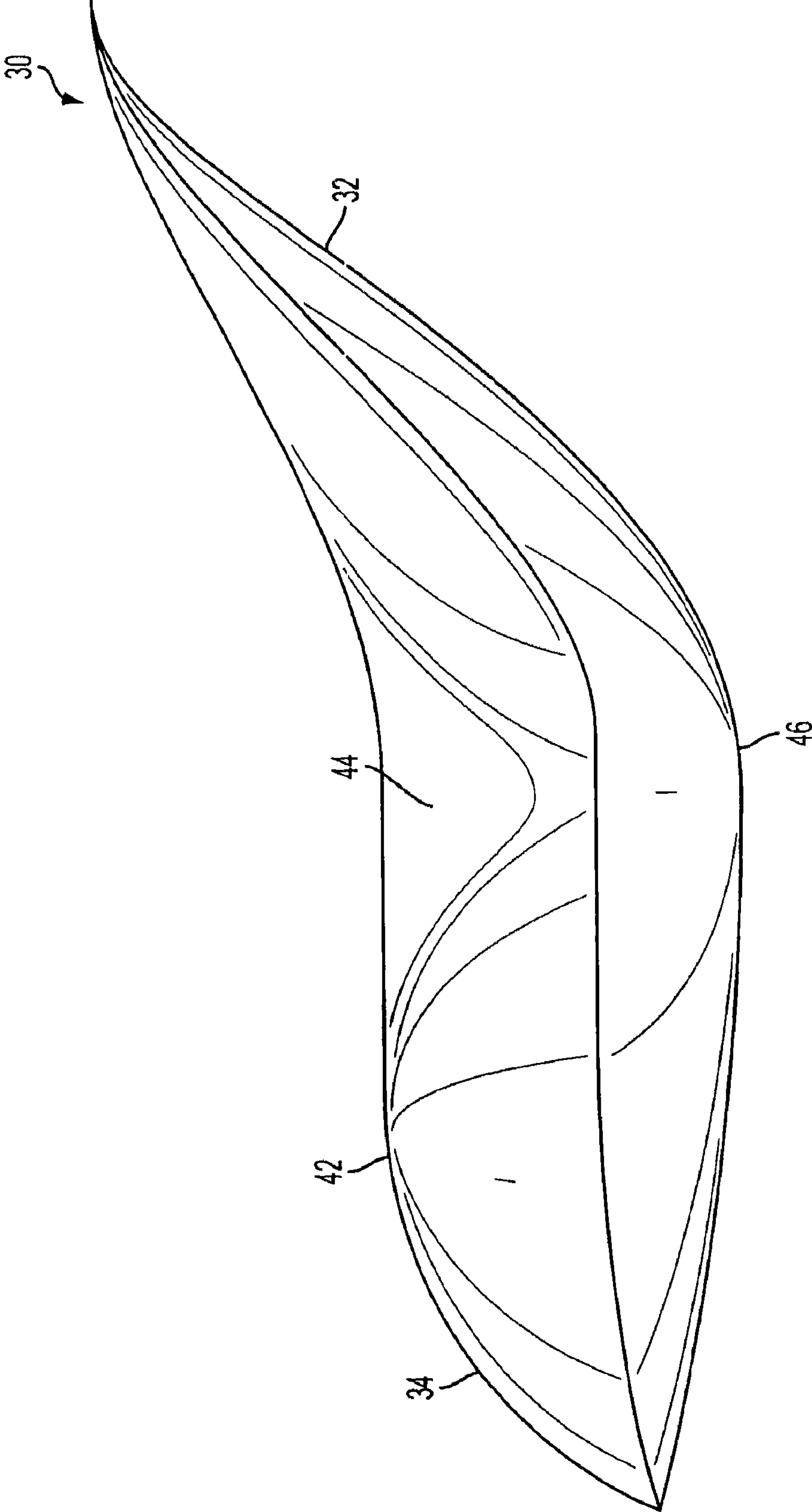

FIG. 10

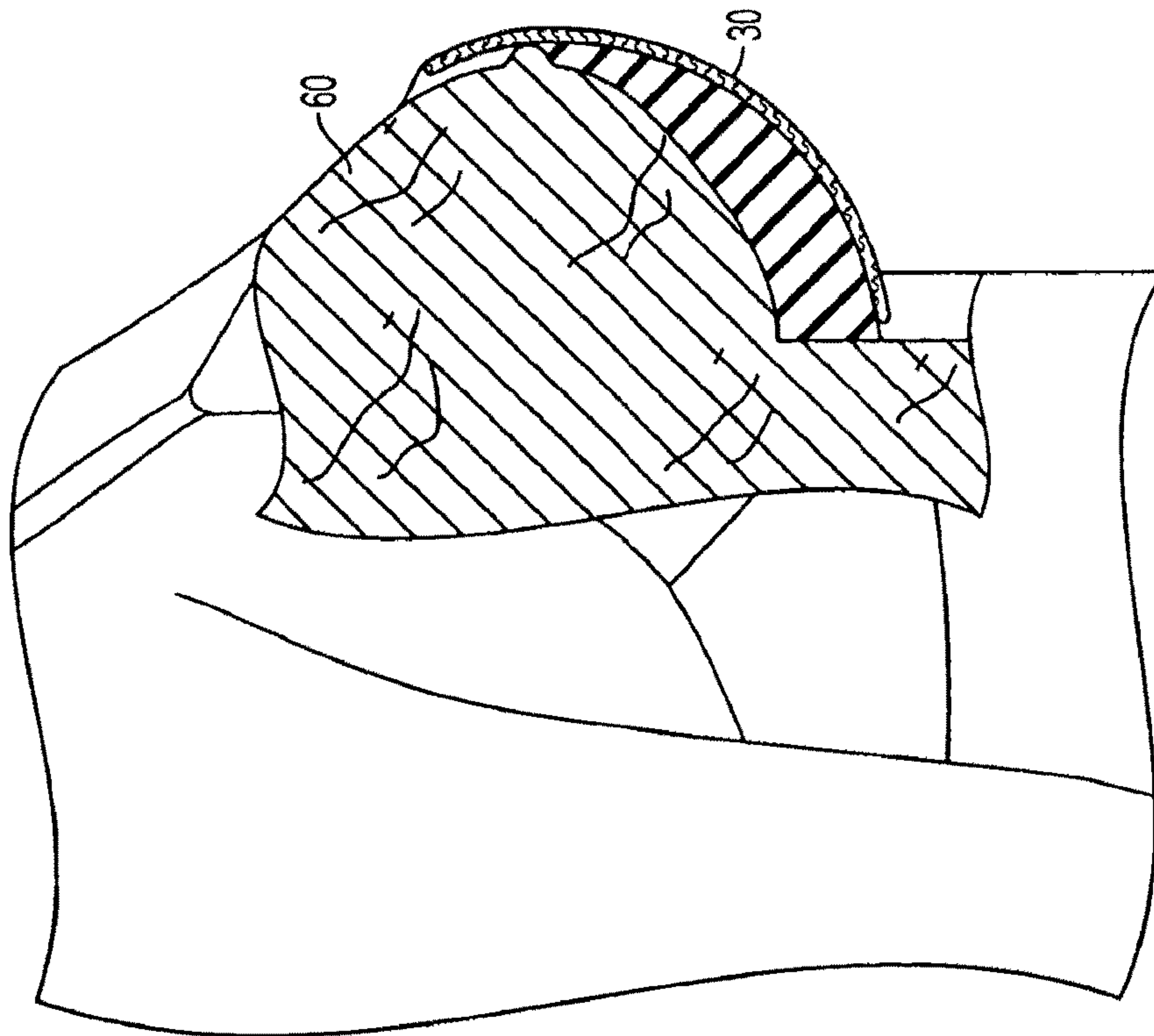

FIG. 11

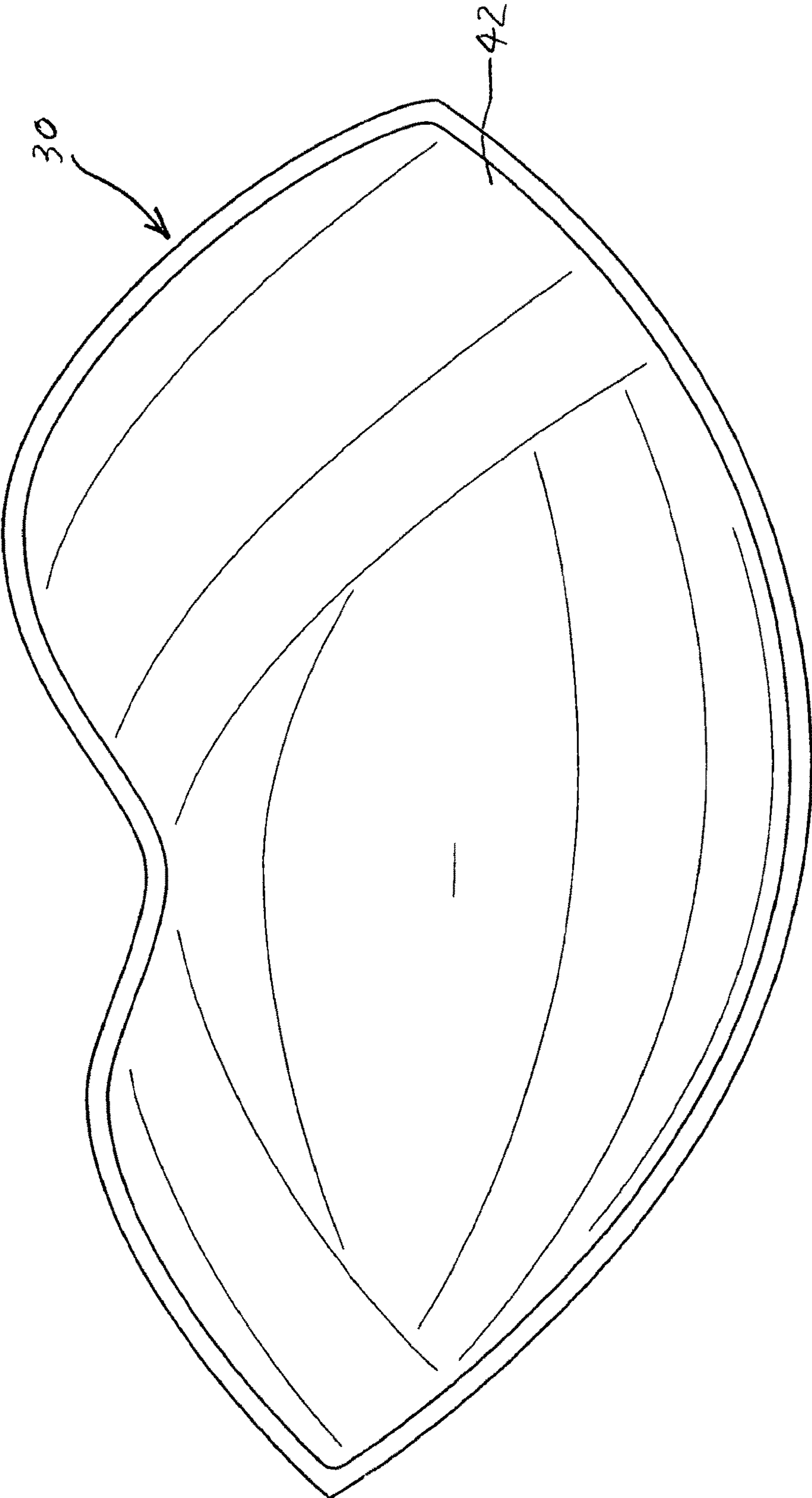

FIG. 12

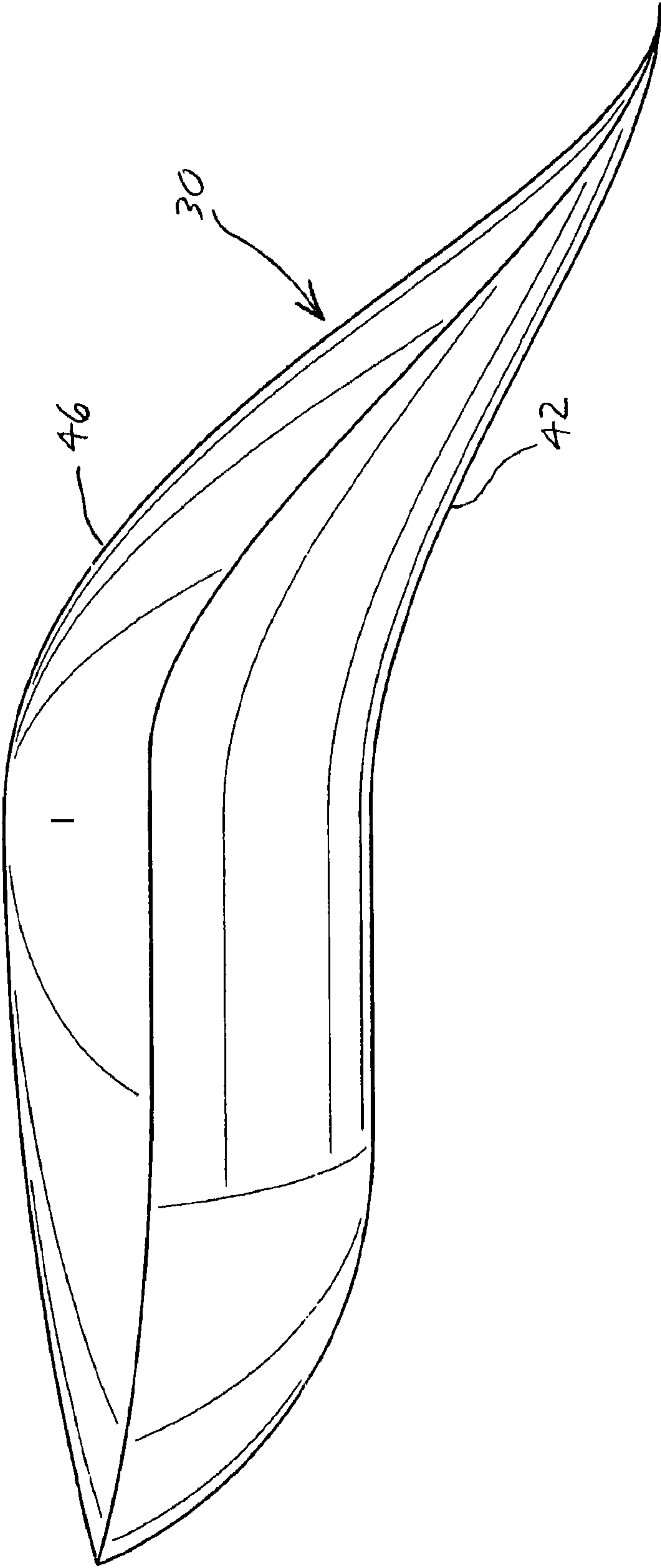

FIG. 13



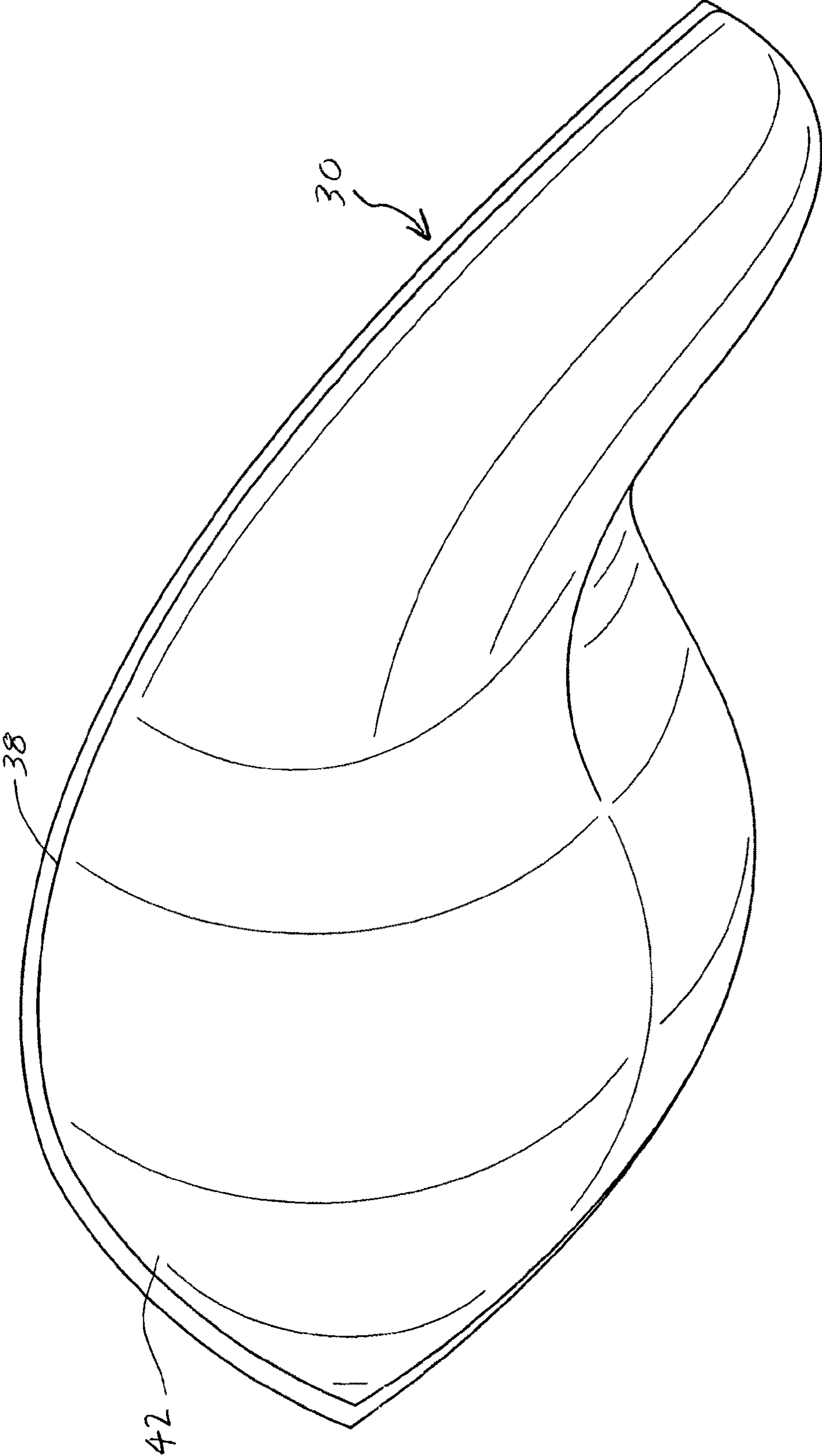

FIG. 14

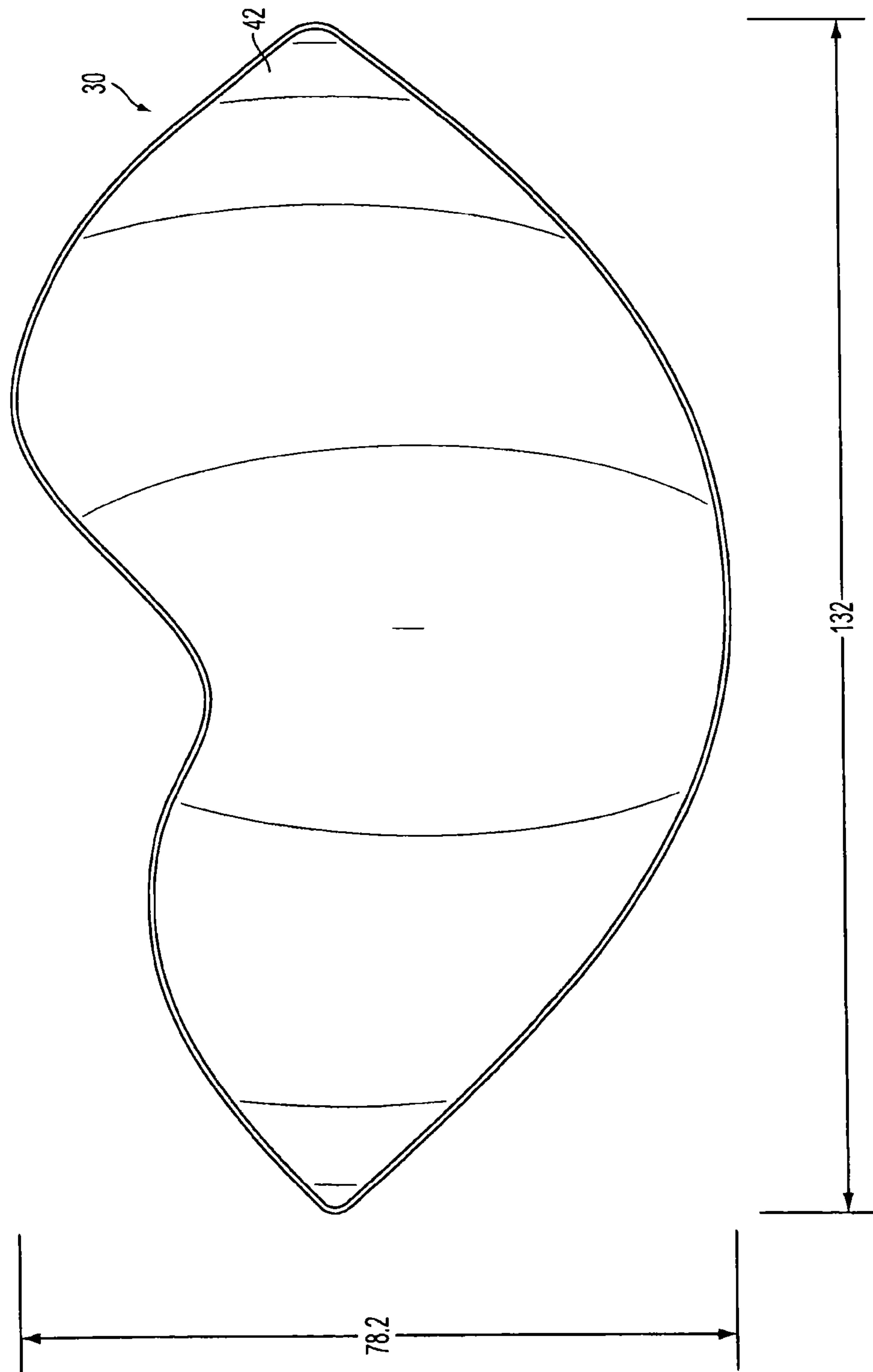

FIG. 15

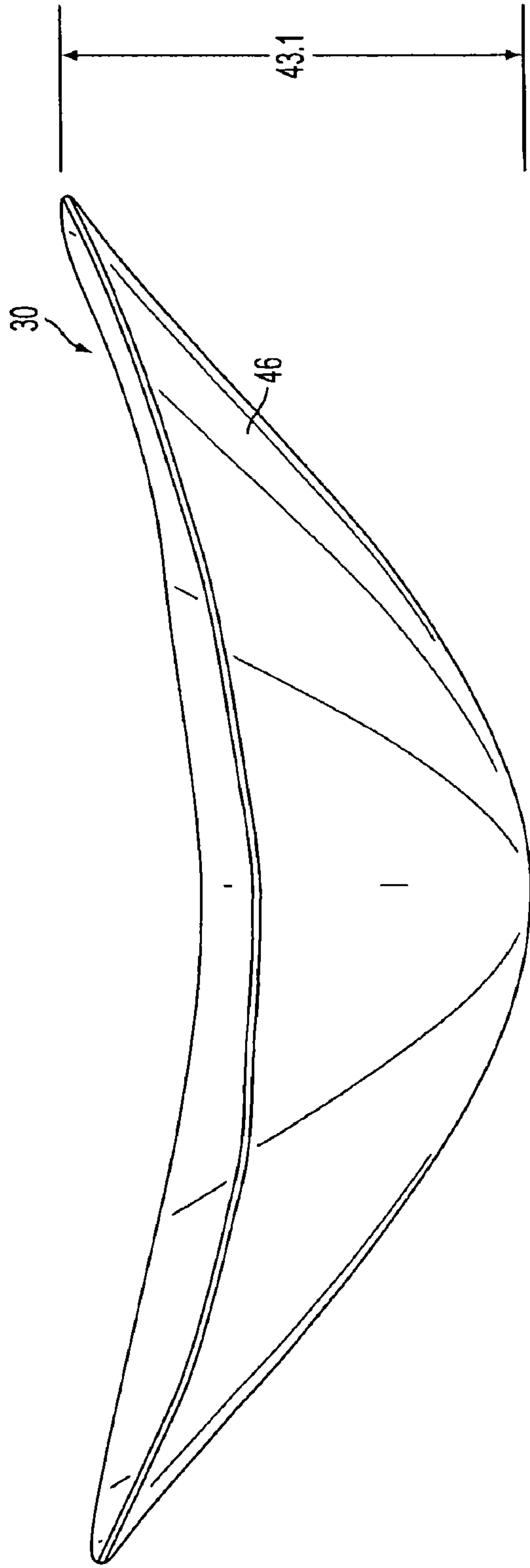

FIG. 16

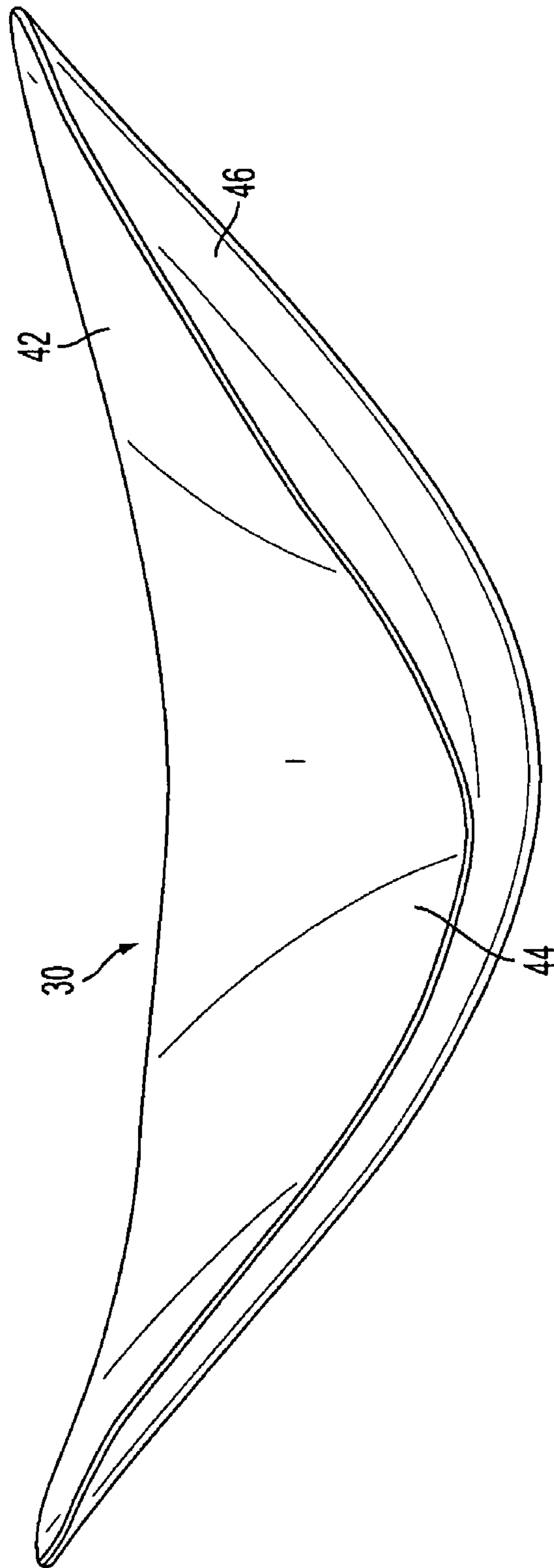

FIG. 17

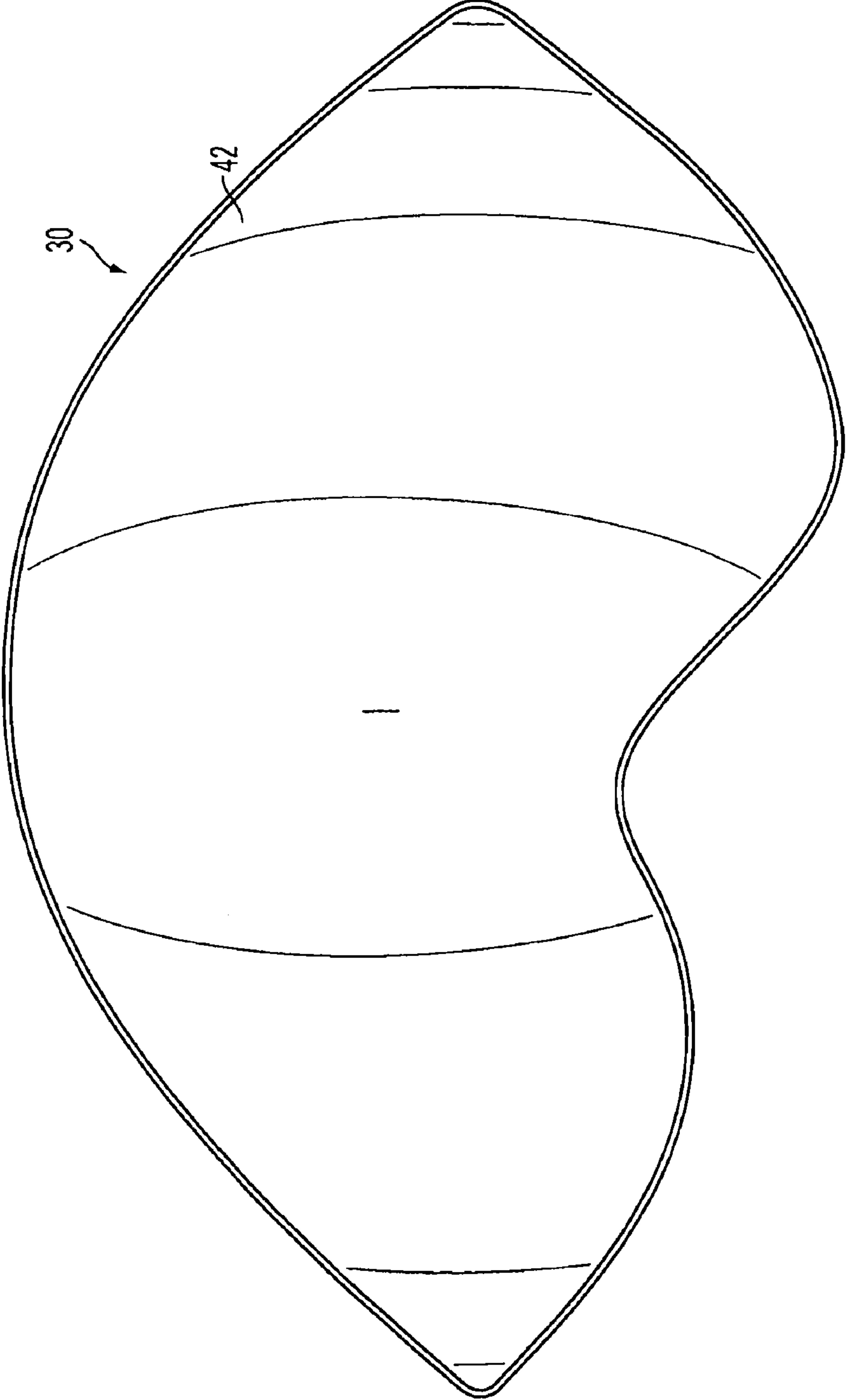

FIG. 18

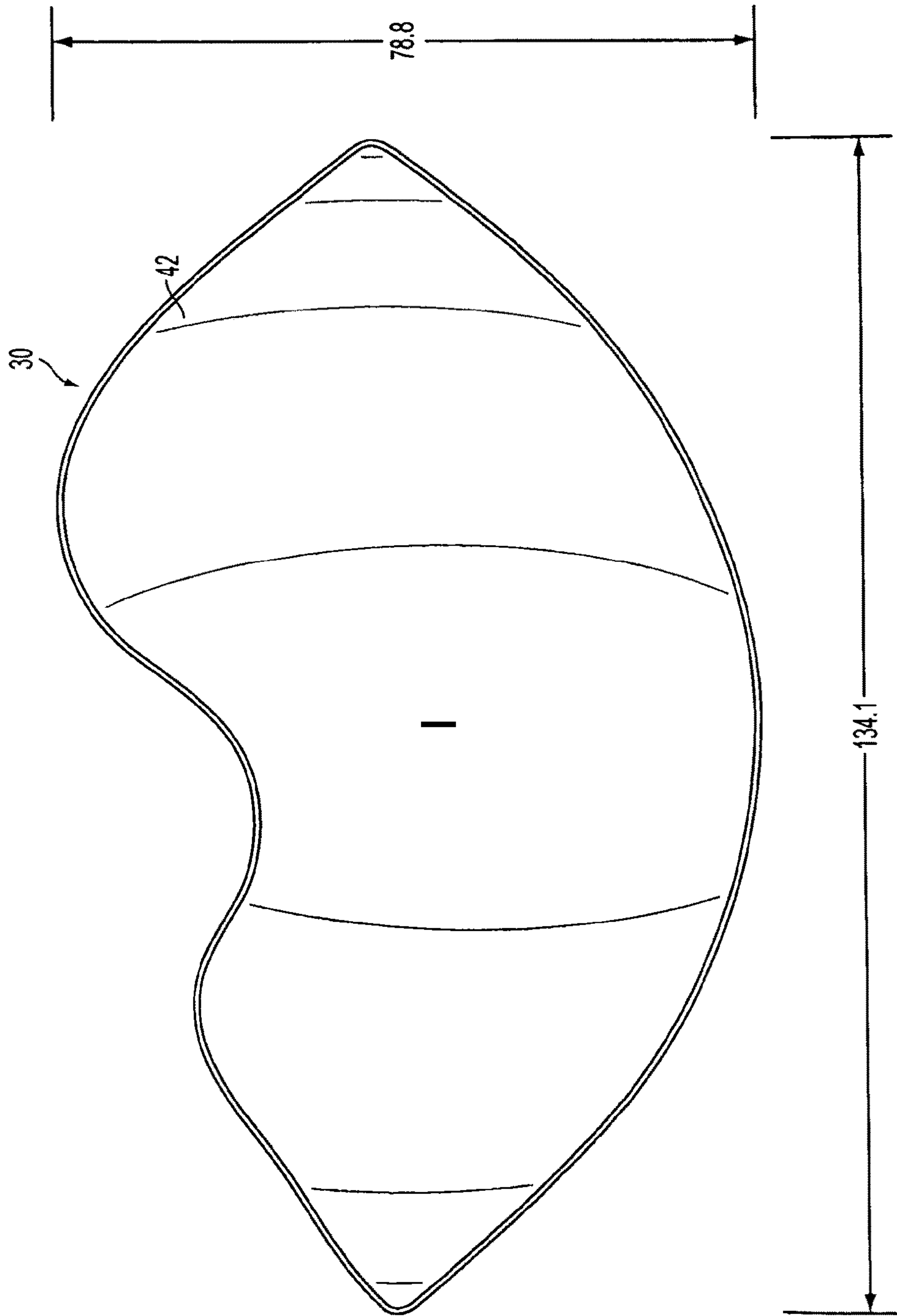

FIG. 19



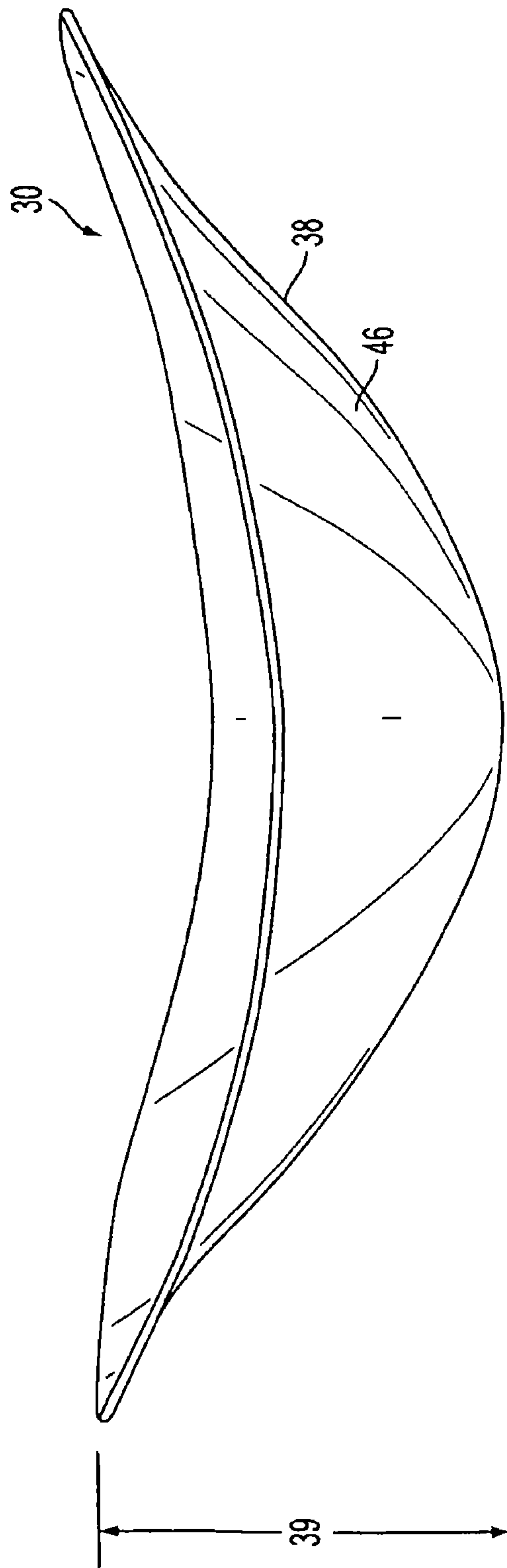

FIG. 20

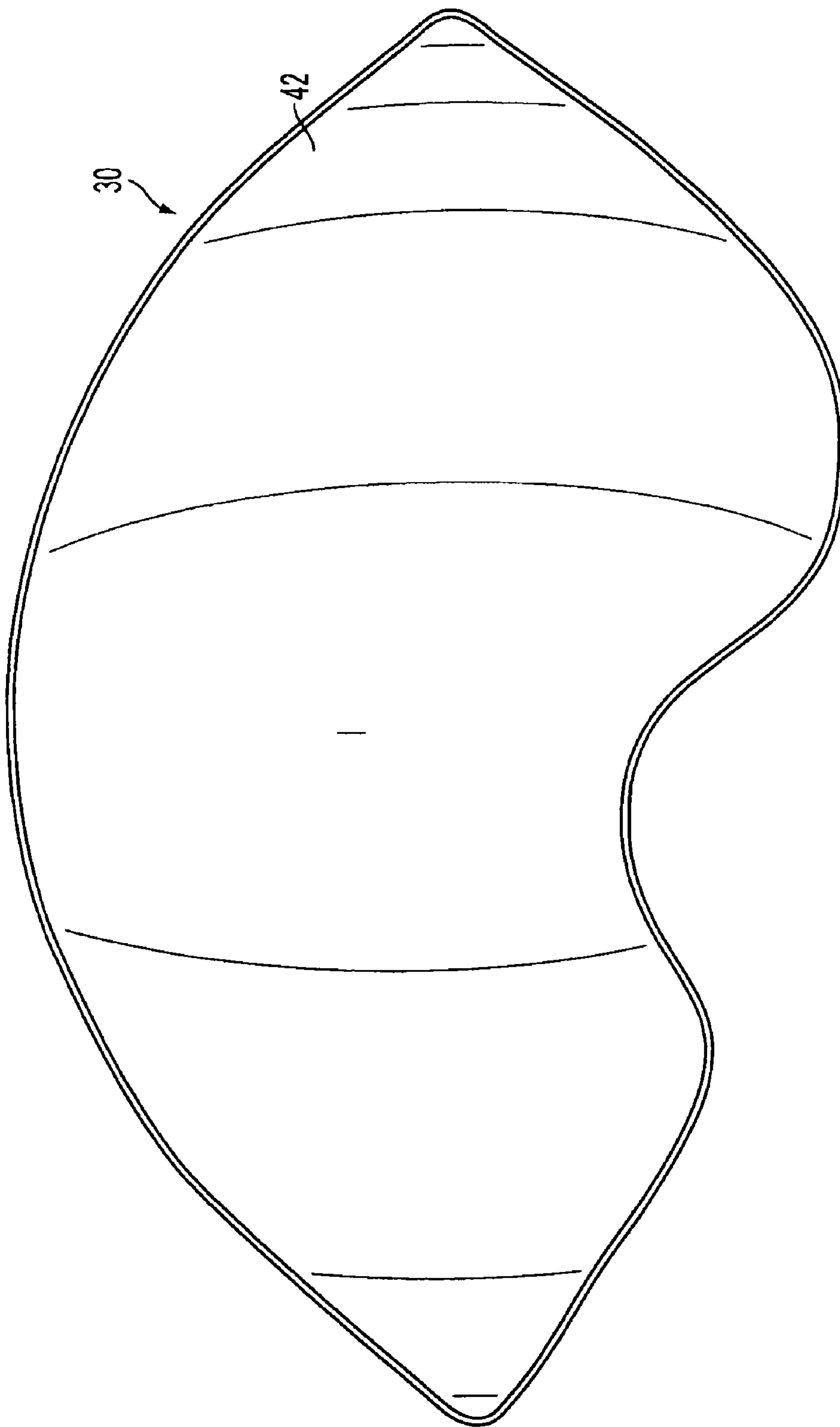

FIG. 21

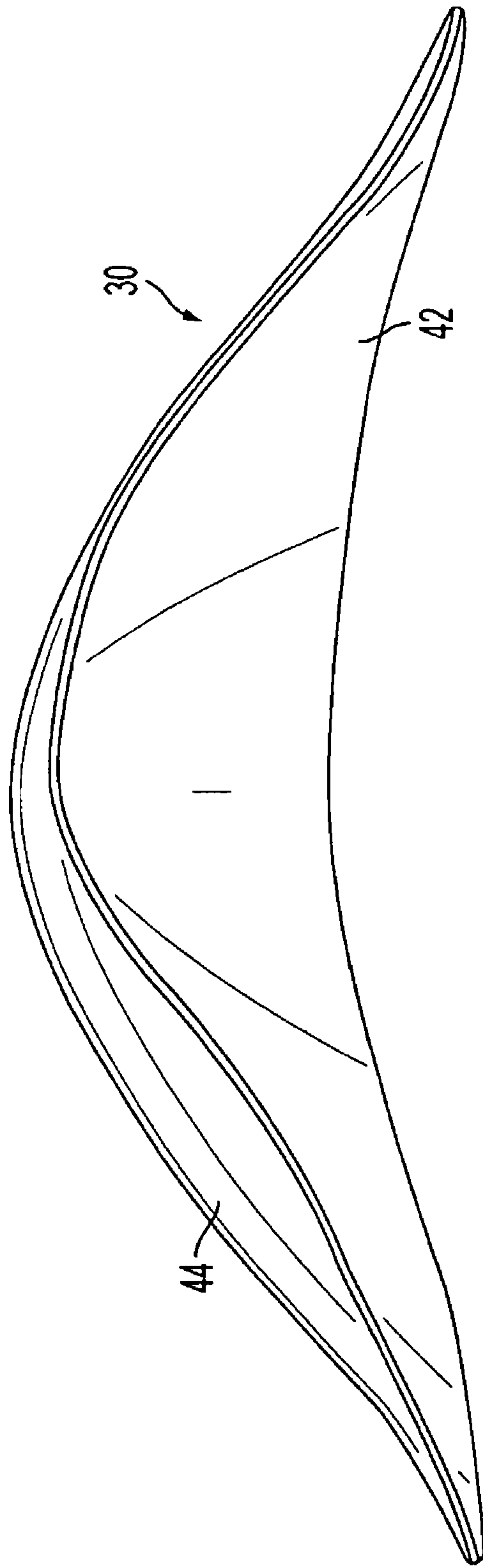

FIG. 22



## ENGINEERED PUSH UP INSERT

**Matter enclosed in heavy brackets [ ] appears in the original patent but forms no part of this reissue specification; matter printed in italics indicates the additions made by reissue; a claim printed with strikethrough indicates that the claim was canceled, disclaimed, or held invalid by a prior post-patent action or proceeding.**

## RELATED APPLICATION

*Notice: More than one reissue application has been filed for the reissue of U.S. Pat. No. 8,216,021. The additional reissue applications are: application Ser. No. 14/327,362, filed Jul. 9, 2014, is a reissue of U.S. Pat. No. 8,216,021; application Ser. No. 14/851,822, filed Sep. 11, 2015, is a continuation reissue application of application Ser. No. 14/327,362. This application claims the benefit of priority of U.S. Provisional Application Ser. No. 61/085,335 filed Jul. 31, 2008.*

## FIELD OF THE INVENTION

The present disclosure is directed to push up inserts for enhancing cleavage and adding volume, thus, improving appearance and the fit of clothing.

## BACKGROUND

Pads are typically inserted into the cups of a bra to fill out the bra. An example of a plastic pad is shown in FIG. 1, illustrating an approximately semi-circular-shaped pad 10. FIG. 2 illustrates another example of a pad 20 having cloth exterior encasing a foam pad. The cloth/foam pad is thin, about 1/2 inch thick at its maximum thickness. The outer cloth exterior of the foam pad 20 is secured by stitching 22 around the periphery 24 of the pad 20.

The prior art foam pads do not push up breasts and do not create cleavage and volume. The prior art plastic and foam pads do not wrap around breasts and are not contoured to the breast to create a natural shape. The prior art pads do not anatomically fit the breasts to provide natural-looking, enhanced cleavage. Thus, it would be desirable to provide a soft insert that is anatomically designed to conform to the breasts to provide a better fit, more lift, greater cleavage, and increased volume.

## SUMMARY OF THE DISCLOSURE

There exists a need for a soft shaping insert that is anatomically designed to conform to and push up the breasts, thereby increasing volume and cleavage, while providing a natural shape.

These and other needs are met by embodiments of the present disclosure, which provide a kidney-shaped push up insert comprising a first lobe, and a second lobe on an opposing side of the insert from the first lobe. The insert has a top side and a bottom side on an opposing side of the insert from the top side. A notch is formed in the top side, between the first lobe and second lobe. The insert has a first main surface having a depression formed adjacent the top side and the depression extends towards the notch. A second main surface opposes the first main surface. The second main surface is a substantially smooth arcuate-shaped surface. The first lobe is narrower in width between the top side and the bottom side than the second lobe, and the second lobe is

thicker between the first main surface and the second main surface than the first lobe. A ratio of [a maximum thickness between the first main surface and the second main surface to] a maximum length between opposing ends of the first lobe and second lobe *to a maximum thickness between the first main surface and the second main surface* is less than about 9.

According to another embodiment of the present disclosure, a kidney-shaped push up insert is provided comprising a first lobe, and a second lobe on an opposing side of the insert from the first lobe. The insert has a top side, and a bottom side on an opposing side of the insert from the top side. A notch is formed in the top side between the first lobe and second lobe. The insert has a first main surface having a depression formed adjacent the top side and the depression extends towards the notch. A second main surface opposes the first main surface. The second main surface is a substantially smooth arcuate-shaped surface. The first lobe is narrower in width between the top side and the bottom side than the second lobe, and the second lobe is thicker between the first main surface and the second main surface than the first lobe. [A ratio of a depth of the notch from a straight line connecting the first lobe and second lobe along the top side of the insert to a width of the insert from the top side to the bottom side at the notch is less than about 4.]

## BRIEF DESCRIPTION OF THE DRAWINGS

FIG. 1 is an illustration of a main surface of a prior art plastic pad.

FIG. 2 is an illustration of a main surface of a prior art cloth over foam pad.

FIG. 3 is an illustration of a main surface of a push up insert according to the present disclosure.

FIG. 4 is an illustration of an opposing main surface of a push up insert according to the present disclosure.

FIG. 5 is an isometric view of a push up insert according to the present disclosure.

FIG. 6 is an isometric view of a push up insert according to the present disclosure.

FIG. 7 illustrates the use of a pushup insert according to the present disclosure.

FIG. 8 illustrates the first main surface of a push up insert according to the present disclosure.

FIG. 9 illustrates the second main surface of a push up insert according to the present disclosure.

FIG. 10 is an edge view of the depression of a pushup insert according to the present disclosure.

FIG. 11 illustrates the push up insert according to the present disclosure lifting up a breast.

FIG. 12 illustrates the first main surface of a push up insert according to the present disclosure.

FIG. 13 is a side view of a push up insert according to the present disclosure.

FIG. 14 is a bottom view of a push up insert according to the present disclosure.

FIG. 15 is a view of the first main surface of a push up insert according to the present disclosure.

FIG. 16 is a side view of the second main surface of a push up insert according to the present disclosure.

FIG. 17 is a side view of the first main surface of a push up insert according to the present disclosure.

FIG. 18 is a view of the first main surface of a push up insert according to the present disclosure.

FIG. 19 is a view of the first main surface of a push up insert according to the present disclosure.



3

FIG. 20 is a side view of the second main surface of a push up insert according to the present disclosure.

FIG. 21 is a view of the first main surface of a push up insert according to the present disclosure.

FIG. 22 is a side view of the first main surface of a push up insert according to the present disclosure.

#### DETAILED DISCLOSURE

According to an embodiment of the present disclosure, a kidney-shaped push up insert 30 is provided comprising a first lobe 32, and a second lobe 34 on an opposing side of the insert 30 from the first lobe 32, as shown in FIG. 3. The insert 30 has a top side 36, and a bottom side 38 on an opposing side of the insert 30 from the top side 36. A notch 40 is formed in the top side 36 between the first lobe 32 and second lobe 34. The insert 30 has a first main surface 42 having a depression 44 formed adjacent the top side 36 and the depression 44 extends towards the notch 40, as shown in FIGS. 4 and 5. A second main surface 46 opposes the first main surface 42. The second main surface 46 is a substantially smooth arcuate-shaped surface. The first lobe 32 is narrower in width between the top side 36 and the bottom side 38 than the second lobe 34, and the second lobe 34 is thicker between the first main surface 42 and the second main surface 46 than the first lobe 32. A ratio of a maximum thickness between the first main surface 42 and the second main surface 46 to a maximum length L between opposing ends 48, 50 of the first lobe 32 and second lobe 34 is less than about 9 (see FIG. 6).

In certain embodiments, the ratio of the maximum thickness between the first main surface 42 and the second main surface 46 to the maximum length L between opposing ends 48, 50 of the first lobe 32 and second lobe 34 ranges from about 2 to about 8. In certain other embodiments, the ratio of the maximum thickness between the first main surface 42 and the second main surface 46 to the maximum length L between opposing ends 48, 50 of the first lobe 32 and second lobe 34 is about 4.5.

According to another embodiment of the present disclosure, a kidney-shaped push up insert 30 is provided comprising a first lobe 32, and a second lobe 34 on an opposing side of the insert 30 from the first lobe 32, as shown in FIG. 3. The insert 30 has a top side 36 and a bottom side 38 on an opposing side of the insert 30 from the top side 36. A notch 40 is formed in the top side 36 between the first lobe 32 and second lobe 34. The insert 30 has a first main surface 42 having a depression 44 formed adjacent the top side 36 and the depression 44 extends towards the notch 40, as shown in FIGS. 4 and 5. A second main surface 46 opposes the first main surface 42. The second main surface 46 is a substantially smooth arcuate-shaped surface. The first lobe 32 is narrower in width between the top side 36 and the bottom side 38 than the second lobe 34, and the second lobe 34 is thicker between the first main surface 42 and the second main surface 46 than the first lobe 32. [A ratio of a depth D of the notch 40 from a straight line SL connecting the first lobe 32 and second lobe 34 along the top side 36 of the insert to a width W of the insert from the top side 36 to the bottom side 38 at the notch 40 is less than about 4 (see FIG. 6).] The straight line SL connects the high point 56 of the first lobe 32 with the high point 54 of the second lobe.

[In certain embodiments, the ratio of the depth of the notch 40 from the straight line SL connecting the first lobe 32 and second lobe 34 along the top side 36 of the insert 30 to the width W of the insert 30 from the top side 36 to the bottom side 38 at the notch 40 ranges from about 1 to less

4

than about 4. In certain embodiments, the ratio of the depth D of the notch 40 from the straight line SL connecting the first lobe 32 and second lobe 34 along the top side 36 of the insert 30 to the width W of the insert from the top side 36 to the bottom side 38 at the notch 40 is about 2.]

In certain embodiments, the top side 36 and bottom side 38 meet at opposing ends 48, 50 of the first lobe 32 and second lobe 34. The push up insert 30 according to embodiments of the present disclosure insert is pliable and sufficiently maintains its shape to push up a breast of a wearer when inserted into a bra cup 62.

When inserted in a bra cup 62, the push up insert 30 according to the present disclosure is inserted so that the first main surface 42 faces the wearer's chest and the opposing second main surface 46 faces away from the wearer towards the bra cup 62. The push up insert 30 is inserted under a breast such that the top side 36 faces upward and the bottom side 38 faces downward. The second lobe 34 is positioned toward the vertical centerline CL of the wearer's chest when the chest is viewed from the front and the first lobe 32 is positioned further away from the vertical centerline CL than the [first] second lobe [32] 34. In this manner, the push up insert 30 is engineered so that the larger second lobe 34 pushes the breast 60 up to enhance cleavage, as shown in FIG. 7. The push up insert 30 is contoured to conform to the body of the wearer and the depression 44 is configured to lift and support the breast 60 of the wearer. The depression 44 is centered about the notch 40 and starts descending towards the notch 40 above the midpoint of the width towards the top side 36. The depression [40] 44 creates a sloped shelf 64, as shown in FIG. 8, which lifts and supports the breast 60, as shown in FIG. 8. FIG. 8 is an isometric view of the first main surface 42 illustrating the first lobe 32, the second lobe 34, the depression 44, the notch 40, and the sloped shelf 64.

In certain embodiments of the present disclosure, the kidney-shaped push up insert can have a maximum length L between opposing ends 48, 50 of about 5 $\frac{5}{8}$  inches, a maximum thickness between the first main surface and second main surface of about 1 $\frac{1}{4}$  inches, a width W from the top side 36 to the bottom side 38 at the notch 40 of about 2 $\frac{5}{8}$  inches, and a depth D of the notch 40 from a straight line SL connecting the first lobe 32 and second lobe 34 along the top side 36 of the insert 30 of about 0.3 inches.

In certain embodiments of the present disclosure, the ratio of [a maximum thickness between the first main surface 42 and the second main surface 46 to] a maximum length L between opposing ends 48, 50 of the first lobe 32 and second lobe 34 to a maximum thickness between the first main surface 42 and the second main surface 46 is set so that the push up insert 30 formed from a certain material will be both sufficiently pliable to conform to the breast and be sufficiently rigid to lift the breast to comfortably provide enhanced cleavage. In certain embodiments, the ratio is set to be less than about 9.

In certain embodiments of the present disclosure, the ratio of a depth D of the notch 40 from a straight line SL connecting the first lobe 32 and second lobe 34 along the top side 36 of the insert to a width W of the insert from the top side 36 to the bottom side 38 at the notch 40 is set so that the push up insert 30 formed from a certain material will be sufficiently pliable and sufficiently lift the breast to comfortably provide enhanced cleavage. [In certain embodiments, the ratio is set to be less than about 4.]

When inserted in a bra cup 62, the engineered push up insert 30 according to the present disclosure increases volume to provide a full cup size increase in apparent breast size. The engineered push up insert 30 is comfortable,



5

invisible under clothing, and is easily inserted into any bra. Pushup inserts **30** according to the present disclosure are stain-resistant and washable.

According to certain embodiments of the present disclosure, the engineered kidney-shaped push up insert **30** comprises a soft, non-porous polymer, that is comfortable to wear, yet it has sufficient rigidity to lift and support the breast **60** of a wearer. In certain embodiments, the non-porous polymer is a silicone. The push up insert **30** can be formed from a single molded, soft polymer, such as a silicone rubber. In other embodiments, the push up insert **30** can comprise an outer surface completely enclosing a gel interior. The gel can be a silicone gel and the outer surface a non-porous polymer film, such as a polymer film selected from the group consisting of silicones polyolefins, polyesters, polyvinyl acetates, polyvinylidene chlorides, and fluoropolymers. The non-porous polymer film outer surface can comprise opposing non-porous polymer films sealed around the periphery **52** of the top and bottom sides **36**, **38**. Alternatively, the periphery **52** represents flashing, which can be optionally removed, in the case of a single piece molded insert **30**.

The two lobe, kidney-shaped, engineered pushup insert **30** of the present disclosure provides increased volume and cleavage over prior art pads. Engineered push up inserts according to the present disclosure provide greater comfort, as they are anatomically designed to conform to the breast, and provide greater support than substantially semi-circular-shaped and fabric over foam bra-filling pads.

Engineered push up inserts according to the present disclosure are molded so that a greater amount of silicone is channeled along the bottom and sides of the push up insert **30** to create lift and maximize cleavage. The push up insert **30** according to the present disclosure can be opaque, translucent, or transparent.

Additional views of engineered push up inserts according to the present disclosure illustrating different features of the push up inserts are shown in FIGS. **9** and **10**. FIG. **9** illustrates the second main surface **46** and its substantially smooth arcuate-shaped surface, and the depression **44** formed on the first main surface **42**. FIG. **10**, looking edge on at the depression **44**, illustrates the difference between the relatively thinner first lobe **32**, and relatively thicker second lobe **34**.

FIG. **11** shows the push up insert **30** pushing up the breast **60** and the pliable push up insert **30** conforming to the breast **60** to increase volume and cleavage, while providing a natural appearance.

FIGS. **12-21** illustrate additional embodiments of push up inserts according to the present disclosure. FIG. **12** is a view of the first main surface **42** according to an embodiment of the present disclosure. FIG. **13** is a side view of a push up insert according to the present disclosure. FIG. **14** is a bottom view of a push up insert according to the present disclosure. FIG. **15** illustrates the first main surface **42** of an embodiment of a push up insert according to the present disclosure, showing the overall dimension in millimeters. FIG. **16** illustrates a side view of the second main surface **46** of an embodiment of a push up insert according to the present disclosure, showing the height dimension in millimeters. FIG. **17** is a side view of the first main surface of an embodiment of a push up insert according to the present disclosure. FIG. **18** is a view of the first main surface of an embodiment of a push up insert according to the present disclosure. FIG. **19** is a view of the first main surface of an embodiment of a push up insert according to the present disclosure showing the overall dimensions in millimeters.

6

FIG. **20** illustrates a side view of the second main surface **46** of an embodiment of a push up insert according to the present disclosure, showing the height dimension in millimeters. FIG. **21** is a view of the first main surface of an embodiment of a push up insert according to the present disclosure. FIG. **22** is a side view of the first main surface of an embodiment of a push up insert according to the present disclosure.

The embodiments illustrated in the instant disclosure are for illustrative purposes only. They should not be construed to limit the claims. As is clear to one of ordinary skill in the art, the instant disclosure encompasses a wide variety of embodiments not specifically illustrated herein. While the compositions and methods of this disclosure have been described in terms of exemplary embodiments, it will be apparent to those of skill in the art that variations may be applied to the compositions and methods and in the steps or in the sequence of steps of the method described herein without departing from the concept, spirit and scope of the invention.

What is claimed is:

**[1.** A kidney-shaped push up insert comprising:

a first lobe;

a second lobe on an opposing side of the bra insert from said first lobe;

a top side;

a bottom side on an opposing side of the bra insert from said top side, wherein a notch is formed in the top side between the first lobe and second lobe;

a first main surface having a depression formed adjacent the top side and extending towards the notch; and

a second main surface opposing said first main surface, wherein the second main surface is a substantially smooth arcuate-shaped surface,

wherein the first lobe is narrower in width between the top side and the bottom side than the second lobe, and the second lobe is thicker between the first main surface and the second main surface than the first lobe,

wherein a ratio of a maximum thickness between the first main surface and the second main surface to a maximum length between opposing ends of the first lobe and second lobe is less than about 9, and

wherein the bra insert is kidney-shaped as viewed from a direction perpendicular to the first main surface or second main surface.]

**[2.** The kidney-shaped push up bra insert according to claim **1**, wherein the ratio of the maximum thickness between the first main surface and the second main surface to the maximum length between opposing ends of the first lobe and second lobe ranges from about 2 to about 8.]

**[3.** The kidney-shaped push up bra insert according to claim **1**, wherein the ratio of the maximum thickness between the first main surface and the second main surface to the maximum length between opposing ends of the first lobe and second lobe is about 4.5.]

**[4.** The kidney-shaped push up bra insert according to claim **1**, wherein the top and bottom sides meet at opposing ends of the first lobe and second lobe.]

**[5.** The kidney-shaped pushup bra insert according to claim **1**, wherein the insert comprises a non-porous polymer.]

**[6.** The kidney-shaped push up bra insert according to claim **1**, wherein the non-porous polymer is a silicone.]

**[7.** The kidney-shaped pushup bra insert according to claim **1**, wherein the bra insert is pliable and pushes up a breast of a wearer when inserted into a bra.]



7

**[8.** The kidney-shaped push up bra insert according to claim 7, wherein the bra insert conforms to the breast of the wearer.]

**[9.** The kidney-shaped pushup bra insert according to claim 8, wherein the depression lifts and supports the breast of the wearer.]

**[10.** The kidney-shaped push up bra insert according to claim 8, wherein the first lobe and the second lobe push up the breast.]

**11.** A kidney-shaped push up bra insert comprising:

a first lobe;

a second lobe on an opposing side of the bra insert from said first lobe;

a top side;

a bottom side on an opposing side of the bra insert from said top side, wherein a notch is formed in the top side between the first lobe and second lobe; **[and]**

a first main surface having a depression formed adjacent the top side and extending towards the notch; *and*

a second main surface opposing said first main surface, wherein the second main surface is a substantially smooth arcuate-shaped surface,

wherein the first lobe is narrower in width between the top side and the bottom side than the second lobe, and the second lobe is thicker between the first main surface and the second main surface than the first lobe,

*wherein the top side of each of the first lobe and the second lobe is substantially convex-shaped,*

*wherein the second lobe is positioned closer to a vertical centerline of a chest of a wearer than the first lobe as viewed from a direction facing the chest,*

**[wherein a ratio of a depth of the notch from a straight line connecting the first lobe and second lobe along the top side of the bra insert to a width of the bra insert from the top side to the bottom side at the notch is less than about 4,]** and

8

wherein the bra insert is kidney-shaped as viewed from a direction perpendicular to the first main surface or second main surface.

**[12.** The kidney-shaped push up insert according to claim 11, wherein the ratio of the depth of the notch from the straight line connecting the first lobe and second lobe along the top side of the bra insert to the width of the bra insert from the top side to the bottom side at the notch ranges from about 1 to less than about 4.]

**[13.** The kidney-shaped push up insert according to claim 11, wherein the ratio of the depth of the notch from the straight line connecting the first lobe and second lobe along the top side of the bra insert to the width of the bra insert from the top side to the bottom side at the notch is about 2.]

**14.** The kidney-shaped push up bra insert according to claim 11, wherein the top and bottom sides meet at opposing ends of the first lobe and second lobe.

**15.** The kidney-shaped push up bra insert according to claim 11, wherein the bra insert comprises a non-porous polymer.

**16.** The kidney-shaped push up bra insert according to claim **[11]** 15, wherein the non-porous polymer is a silicone.

**17.** The kidney-shaped push up bra insert according to claim 11, wherein the bra insert is pliable and pushes up a breast of a wearer when inserted into a bra.

**18.** The kidney-shaped push up bra insert according to claim 17, wherein the bra insert conforms to the breast of the wearer.

**19.** The kidney-shaped push up bra insert according to claim 18, wherein the depression lifts and supports the breast of the wearer.

**20.** The kidney-shaped push up bra insert according to claim 18, wherein the first lobe and second lobe push up the breast.

\* \* \* \* \*

UNITED STATES PATENT AND TRADEMARK OFFICE  
**CERTIFICATE OF CORRECTION**

PATENT NO. : RE46,407 E  
APPLICATION NO. : 14/851822  
DATED : May 23, 2017  
INVENTOR(S) : MacKinnon

Page 1 of 1

It is certified that error appears in the above-identified patent and that said Letters Patent is hereby corrected as shown below:

In the Specification

At Column 1, under the heading "RELATED APPLICATION," replace Lines 13-18 (approx.) and the portion of Line 19 (approx.) that includes "14/327,362. This application," with the following:

*--NOTICE: More than one reissue application has been filed for the reissue of U.S. Patent No. 8,216,021 B1. The reissue applications are U.S. Reissue Patent Application No. 16/661,764, filed on October 23, 2019, which is a continuation reissue application of U.S. Reissue Patent Application No. 15/594,295, filed on May 12, 2017, now U.S. Reissue Patent No. RE47,668 E, issued October 29, 2019, which is a continuation reissue application of U.S. Reissue Patent Application Serial No. 14/851,822, filed on September 11, 2015 (the present application), now U.S. Reissue Patent No. RE46,407 E, issued May 23, 2017, which is a continuation reissue application of U.S. Reissue Patent Application Serial No. 14/327,362, filed on July 9, 2014, now U.S. Reissue Patent No. RE45,838 E, issued January 12, 2016, which is a reissue application of U.S. Patent Application Serial No. 12/461,116, filed July 31, 2009, now U.S. Patent No. 8,216,021 B1, issued July 10, 2012, which--*

Signed and Sealed this  
Twentieth Day of October, 2020

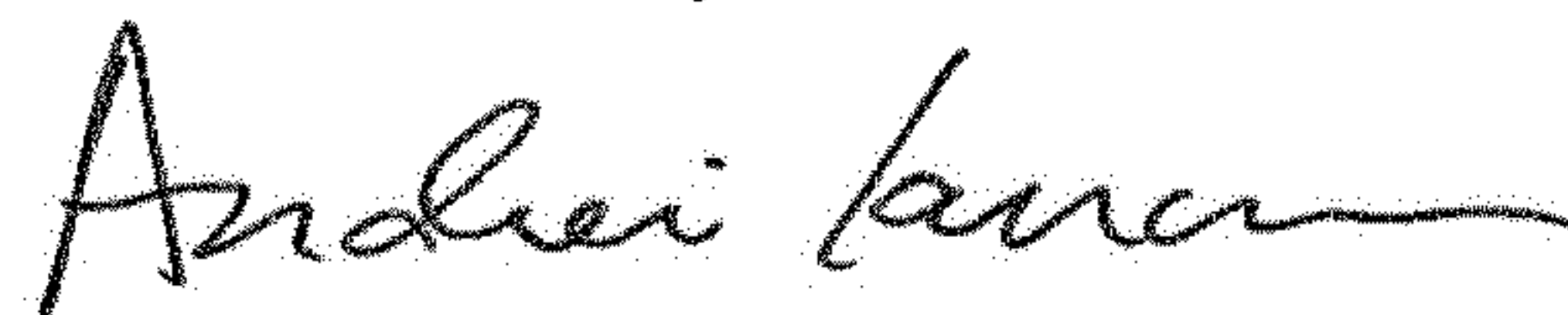

Andrei Iancu  
Director of the United States Patent and Trademark Office