



US00RE46300E

(19) **United States**
(12) **Reissued Patent**
Popov et al.

(10) **Patent Number:** **US RE46,300 E**
(45) **Date of Reissued Patent:** ***Feb. 7, 2017**

(54) **SPINDLE MOTOR HAVING A FLUID DYNAMIC BEARING SYSTEM AND A STATIONARY SHAFT**

(51) **Int. Cl.**
H02K 5/16 (2006.01)
F16C 33/74 (2006.01)
(Continued)

(71) Applicant: **Minebea Co., Ltd.**, Nagano-ken (JP)

(52) **U.S. Cl.**
CPC *F16C 33/745* (2013.01); *F16C 17/107* (2013.01); *F16C 33/1085* (2013.01); *H02K 5/1677* (2013.01); *F16C 2370/12* (2013.01)

(72) Inventors: **Vladimir V. Popov**, Villingen-Schwenningen (DE); **Jürgen Fleig**, St. Georgen (DE); **Martin Bauer**, Villingen-Schwenningen (DE); **Guido Schmid**, Triberg (DE); **Olaf Winterhalter**, Epfendorf (DE); **Matthias Wildpreth**, Villingen-Schwenningen (DE); **Thomas Fuss**, Rottweil (DE); **Martin Engesser**, Donaueschingen (DE); **Stefan Schwamberger**, Villingen-Schwenningen (DE)

(58) **Field of Classification Search**
CPC . H02K 5/1677; H02K 5/1672; F16C 2370/12; F16C 33/107; F16C 17/107; F16C 17/10
(Continued)

(73) Assignee: **MINEBEA CO., LTD.**, Nagano-Ken (JP)

(56) **References Cited**
U.S. PATENT DOCUMENTS
5,623,382 A 4/1997 Moritan
6,071,014 A 6/2000 Lee
(Continued)

(*) Notice: This patent is subject to a terminal disclaimer.

FOREIGN PATENT DOCUMENTS
DE 102005005414 10/2006
DE 102007055516 8/2008
(Continued)

(21) Appl. No.: **13/946,142**

(22) Filed: **Jul. 19, 2013**

Related U.S. Patent Documents

Reissue of:
(64) Patent No.: **7,982,349**
Issued: **Jul. 19, 2011**
Appl. No.: **12/313,898**
Filed: **Nov. 25, 2008**

OTHER PUBLICATIONS
Reissue Application Filing Guide for Applications filed on or after Sep. 16, 2012.*
Primary Examiner — Kenneth J Whittington
(74) *Attorney, Agent, or Firm* — Cooper & Dunham LLP

U.S. Applications:
(63) Continuation of application No. 13/945,043, filed on Jul. 18, 2013, now Pat. No. Re. 45,387, which is an
(Continued)

(30) **Foreign Application Priority Data**

Nov. 30, 2007 (DE) 10 2007 058 150
Sep. 19, 2008 (DE) 10 2008 048 079
Oct. 21, 2008 (DE) 10 2008 052 469

(57) **ABSTRACT**
The invention relates to a spindle motor having a fluid dynamic bearing system comprising axial and radial bearings that contains a rotor component (14) which encloses a stationary shaft (12), which in turn is connected at both its ends to axially aligned bearing parts (16; 18) that are fashioned such that they form capillary sealing gaps (32; 34), a recirculation channel (28) filled with bearing fluid that connects the remote regions of the bearing to each other, and
(Continued)

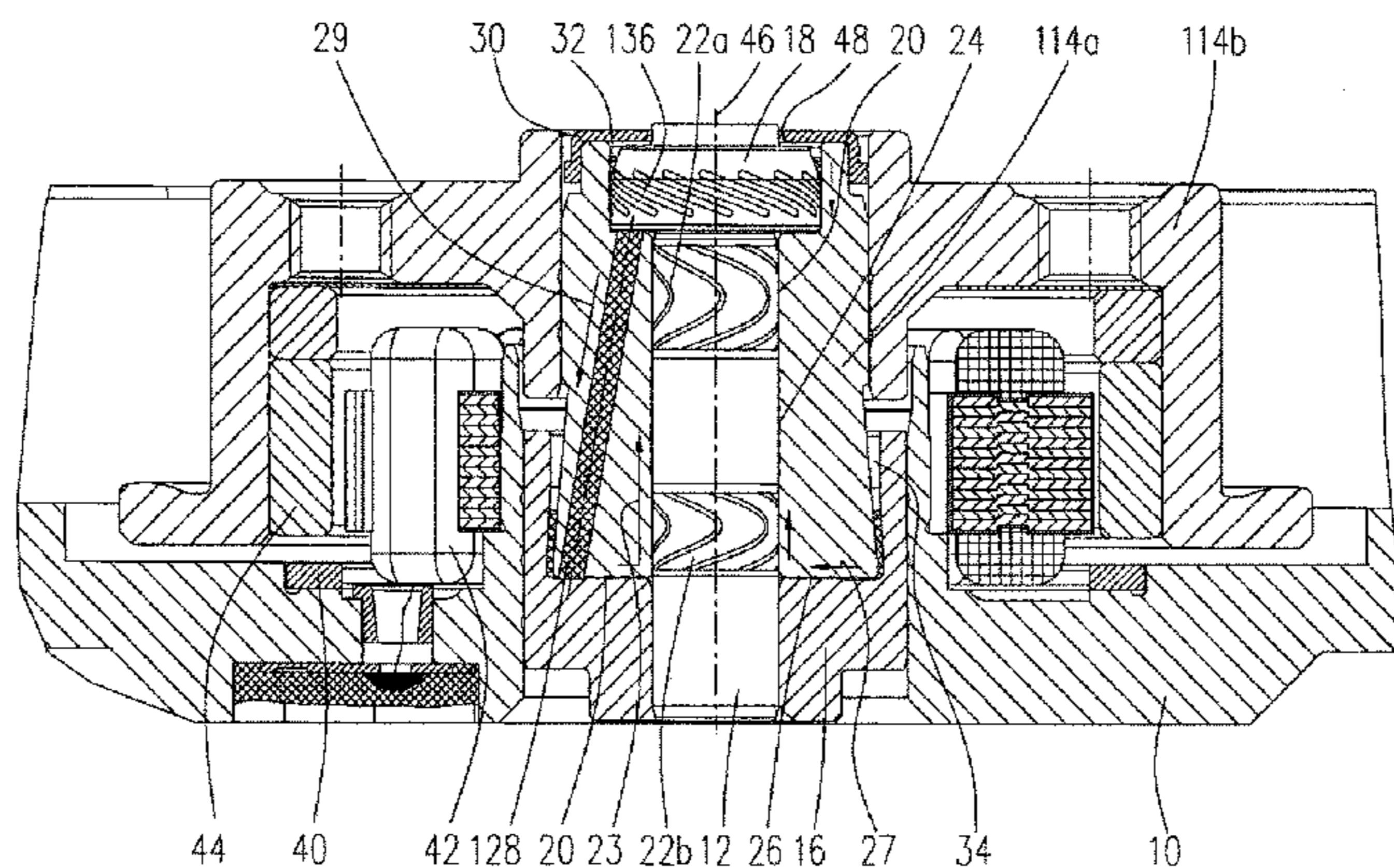

US RE46,300 E

Page 2

an electromagnetic drive system (42, 44) for driving the rotor component.

37 Claims, 10 Drawing Sheets

Related U.S. Application Data

application for the reissue of Pat. No. 7,982,349, which is an application for the reissue of Pat. No. 7,982,349.

(51) **Int. Cl.**

F16C 33/10 (2006.01)
H02K 5/167 (2006.01)
F16C 17/10 (2006.01)

(58) **Field of Classification Search**

USPC 310/90, 51; 384/100, 107; 360/51, 90
See application file for complete search history.

(56) **References Cited**

U.S. PATENT DOCUMENTS

6,183,135 B1 * 2/2001 Kloeppel et al. 384/112
6,371,650 B1 4/2002 Goto

6,397,470 B1 6/2002 Saichi
6,404,087 B1 6/2002 Ichiyama
6,900,567 B2 5/2005 Aiello
6,982,510 B1 * 1/2006 Ajello et al. 310/90
6,991,376 B2 1/2006 Aiello
7,056,024 B2 * 6/2006 Weingord et al. 384/100
7,133,250 B2 * 11/2006 Herndon et al. 360/99.08
7,234,868 B2 6/2007 Tiller
2004/0156568 A1 8/2004 Woldemar
2004/0165797 A1 * 8/2004 Oku et al. 384/119
2005/0207060 A1 9/2005 Leblanc
2006/0222276 A1 * 10/2006 Uenosono 384/107
2006/0291757 A1 12/2006 LeBlanc
2007/0133911 A1 6/2007 Nishimoto 384/100
2007/0210654 A1 9/2007 Ueda
2008/0101739 A1 * 5/2008 Wildpreth et al. 384/110

FOREIGN PATENT DOCUMENTS

DE 102008052469 6/2009
JP 2003333798 11/2003
JP 2005304290 10/2005
JP 2006071087 3/2006
JP 2006283773 10/2006
JP 200724199 2/2007
JP 2007024199 2/2007
JP 2007155093 6/2007

* cited by examiner

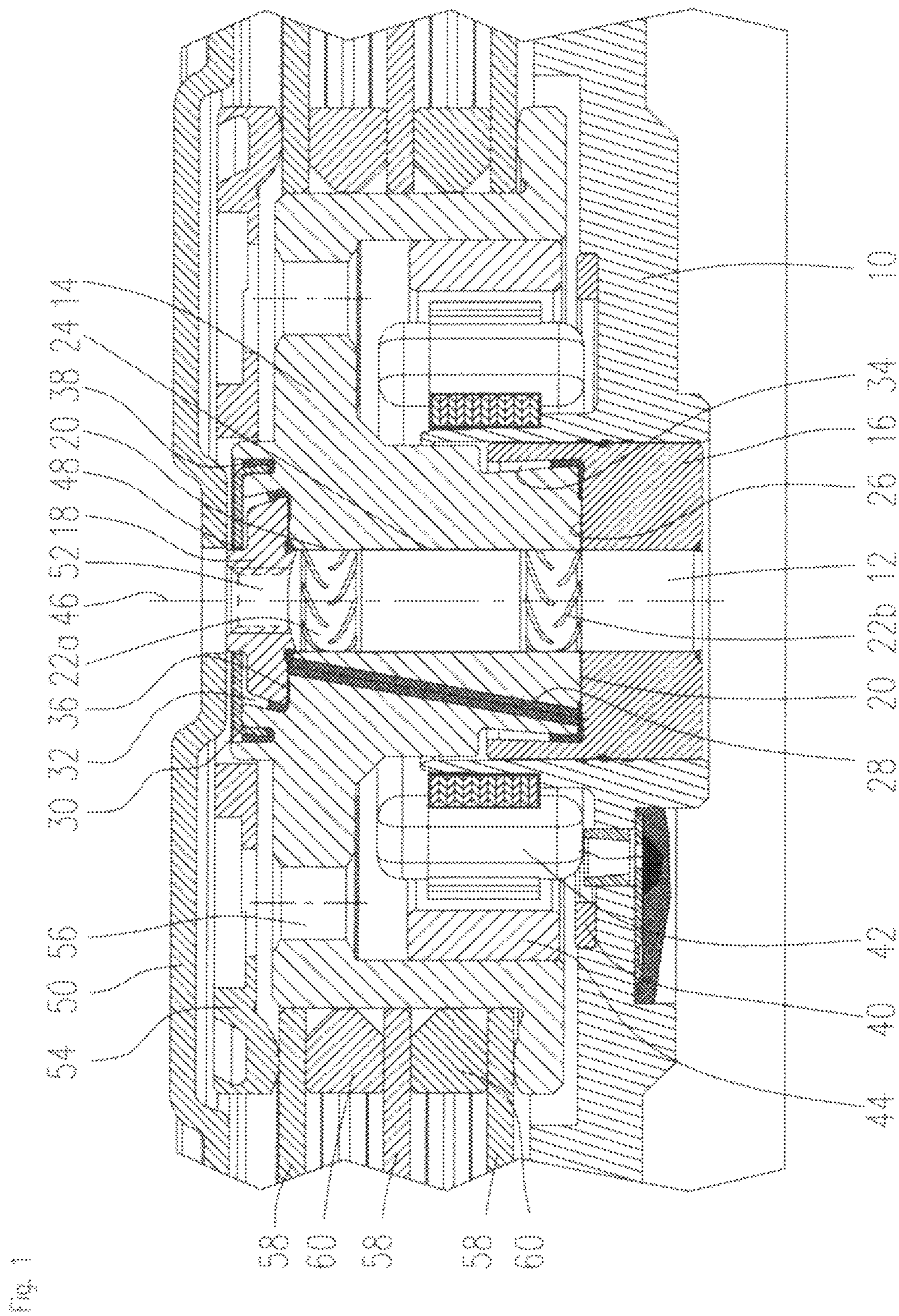

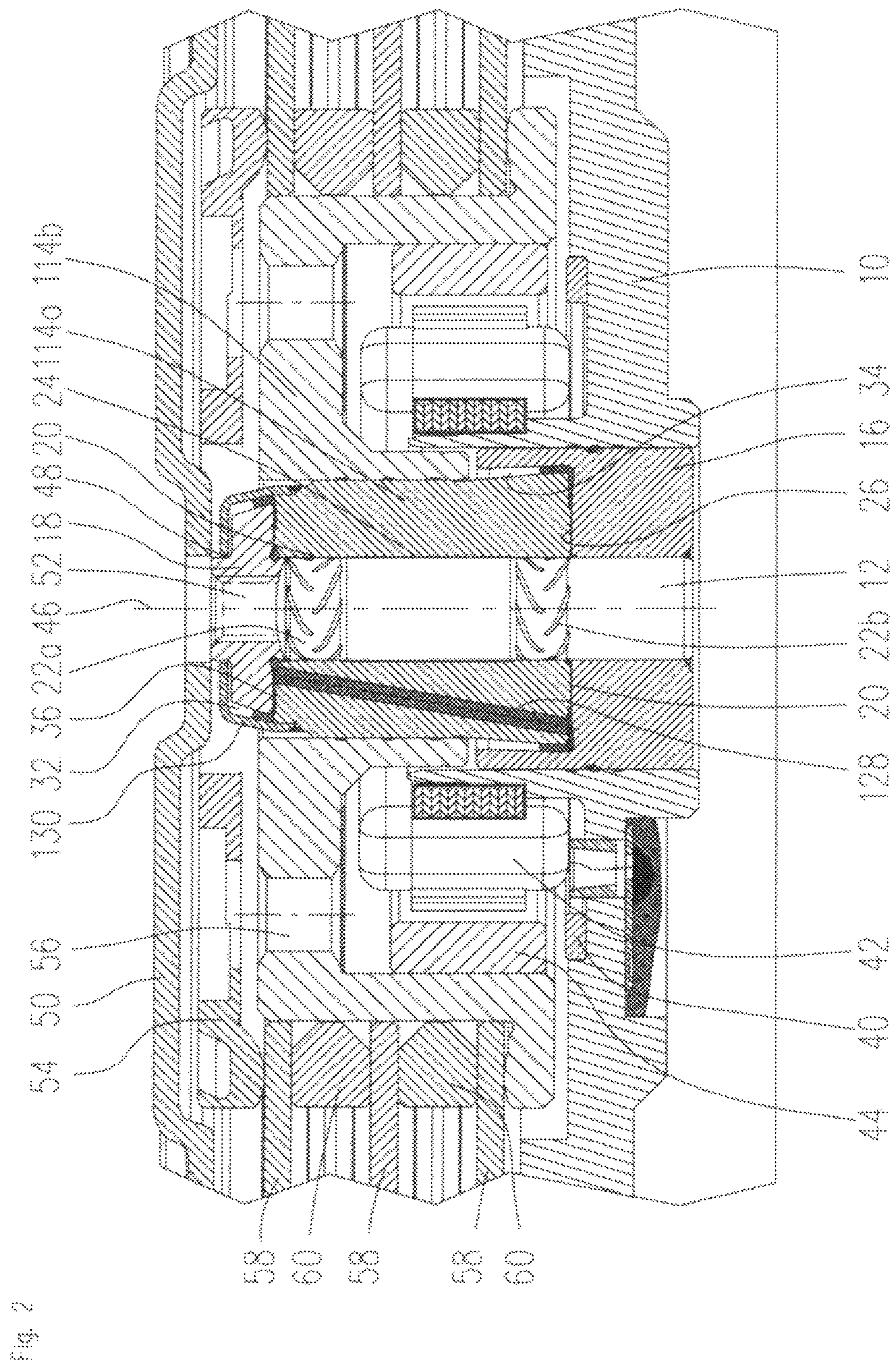

Fig. 3

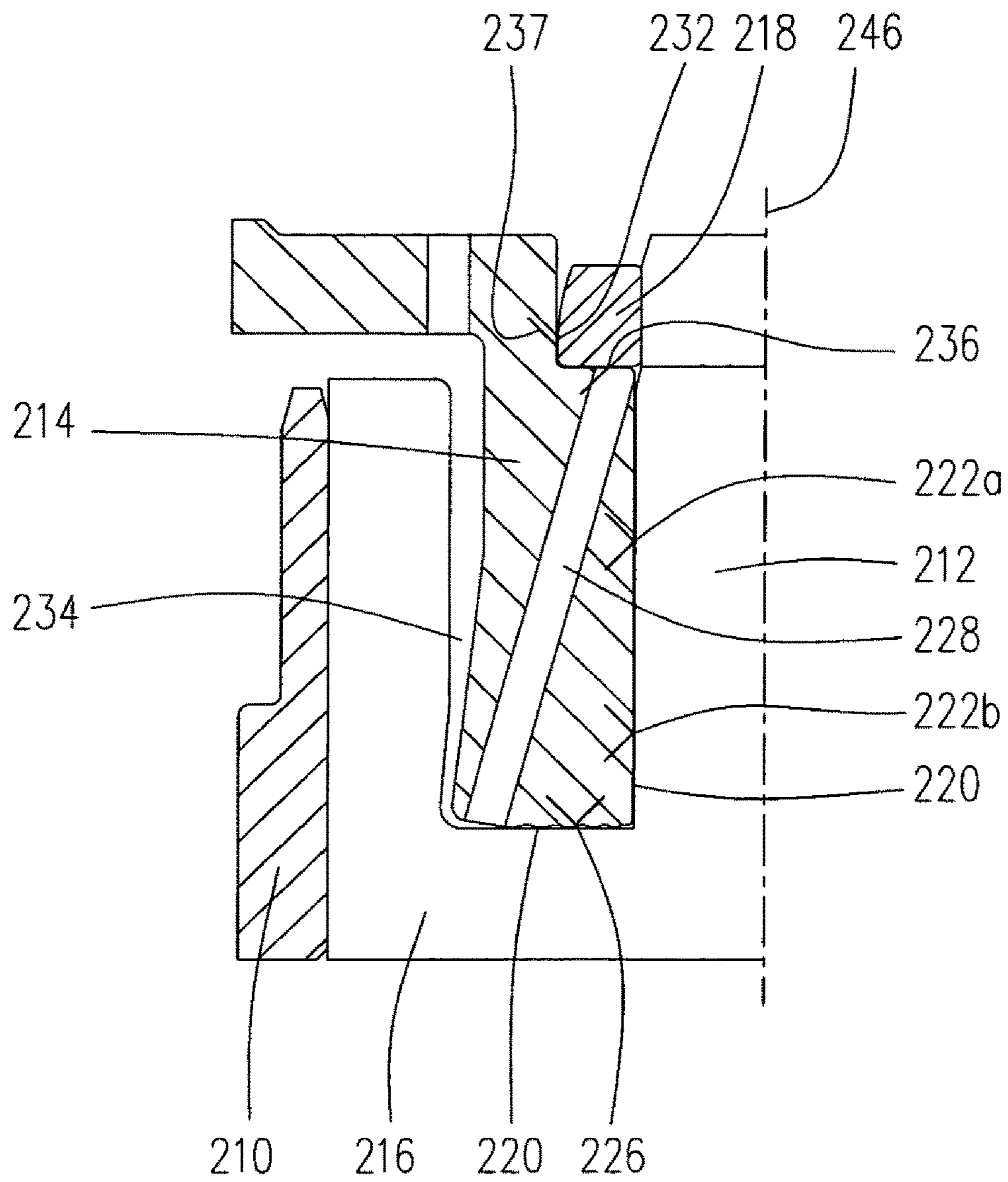

Fig. 4

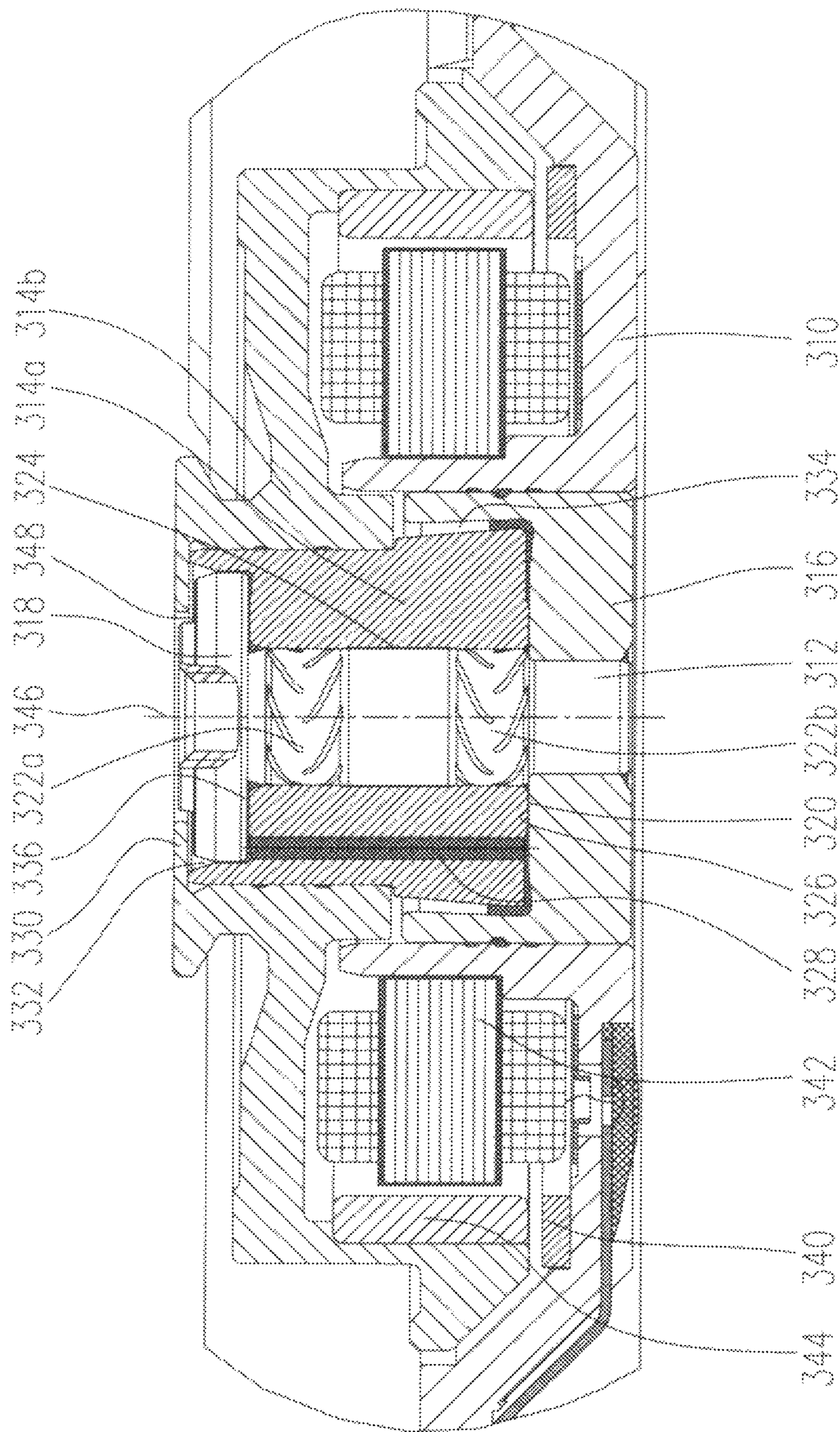

Fig. 5

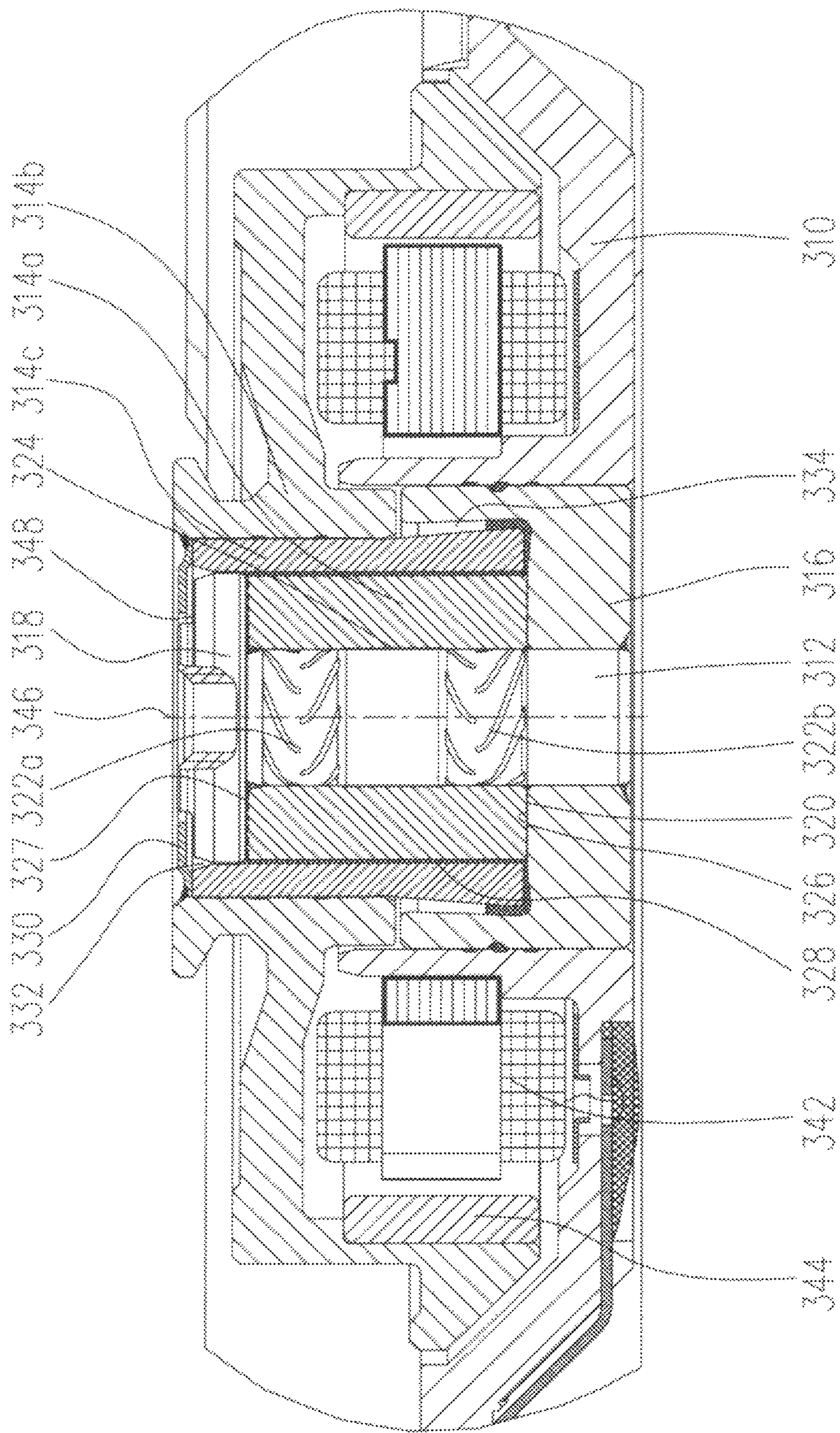

Fig. 6

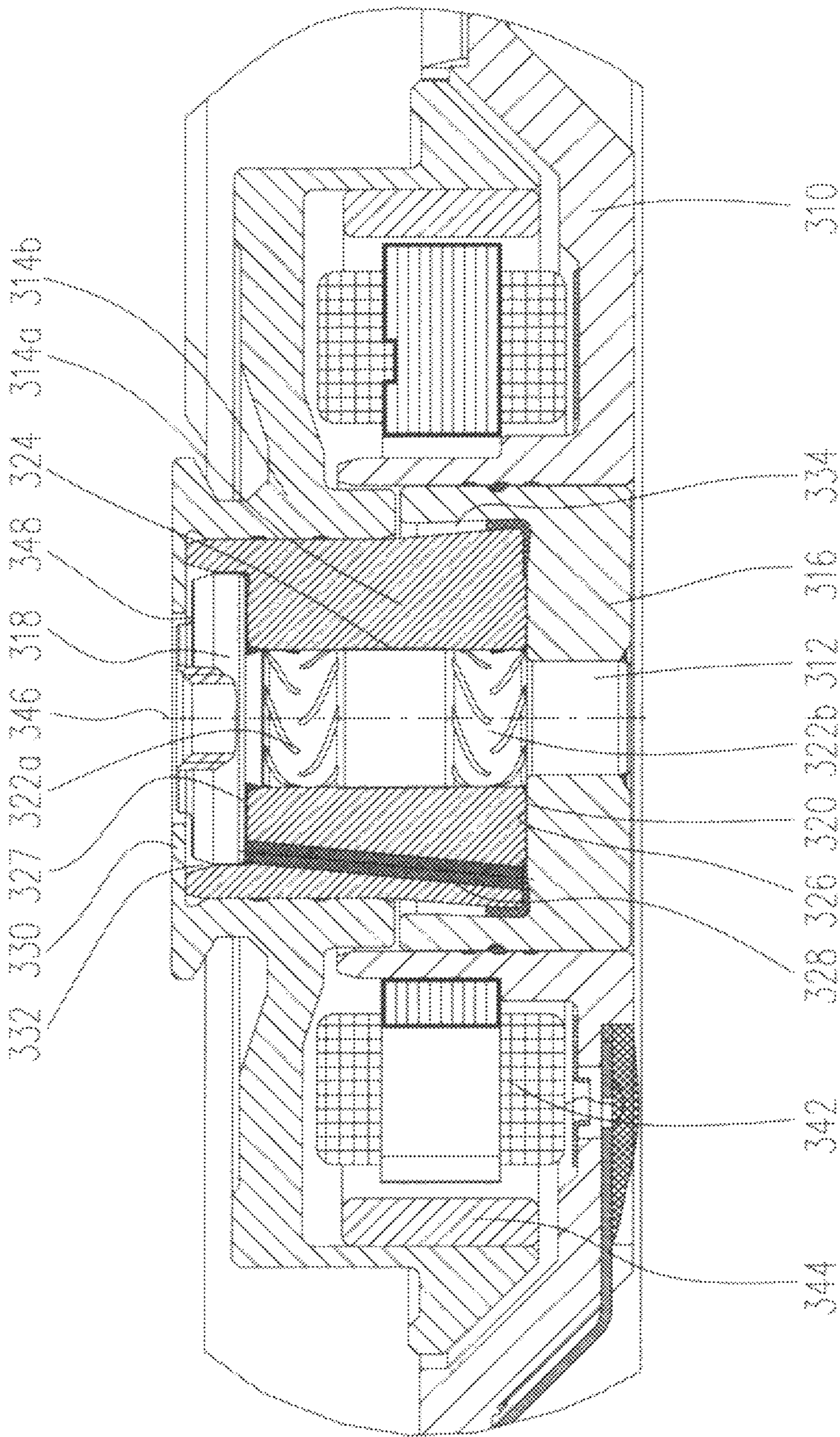

Fig. 7

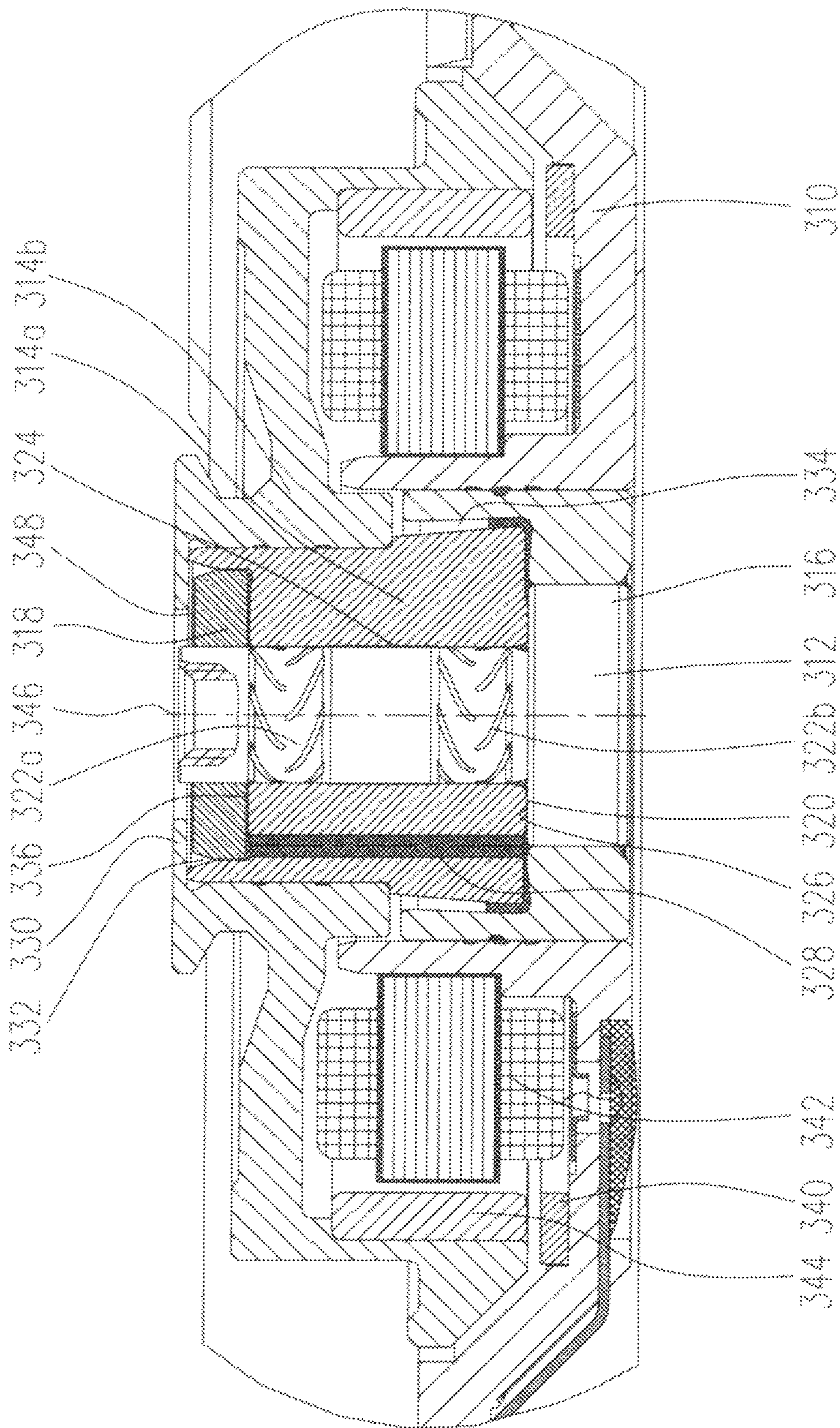

Fig. 8

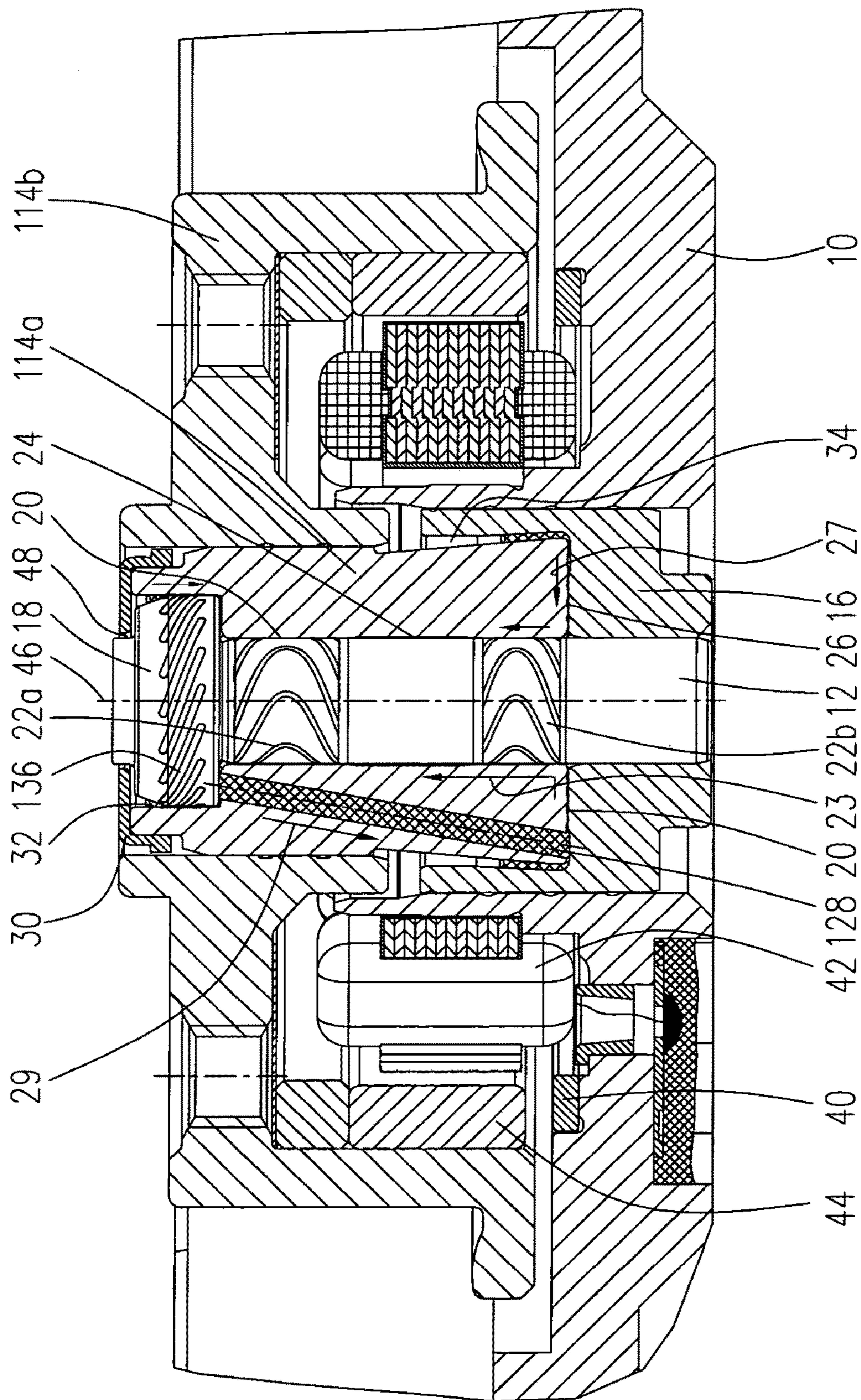
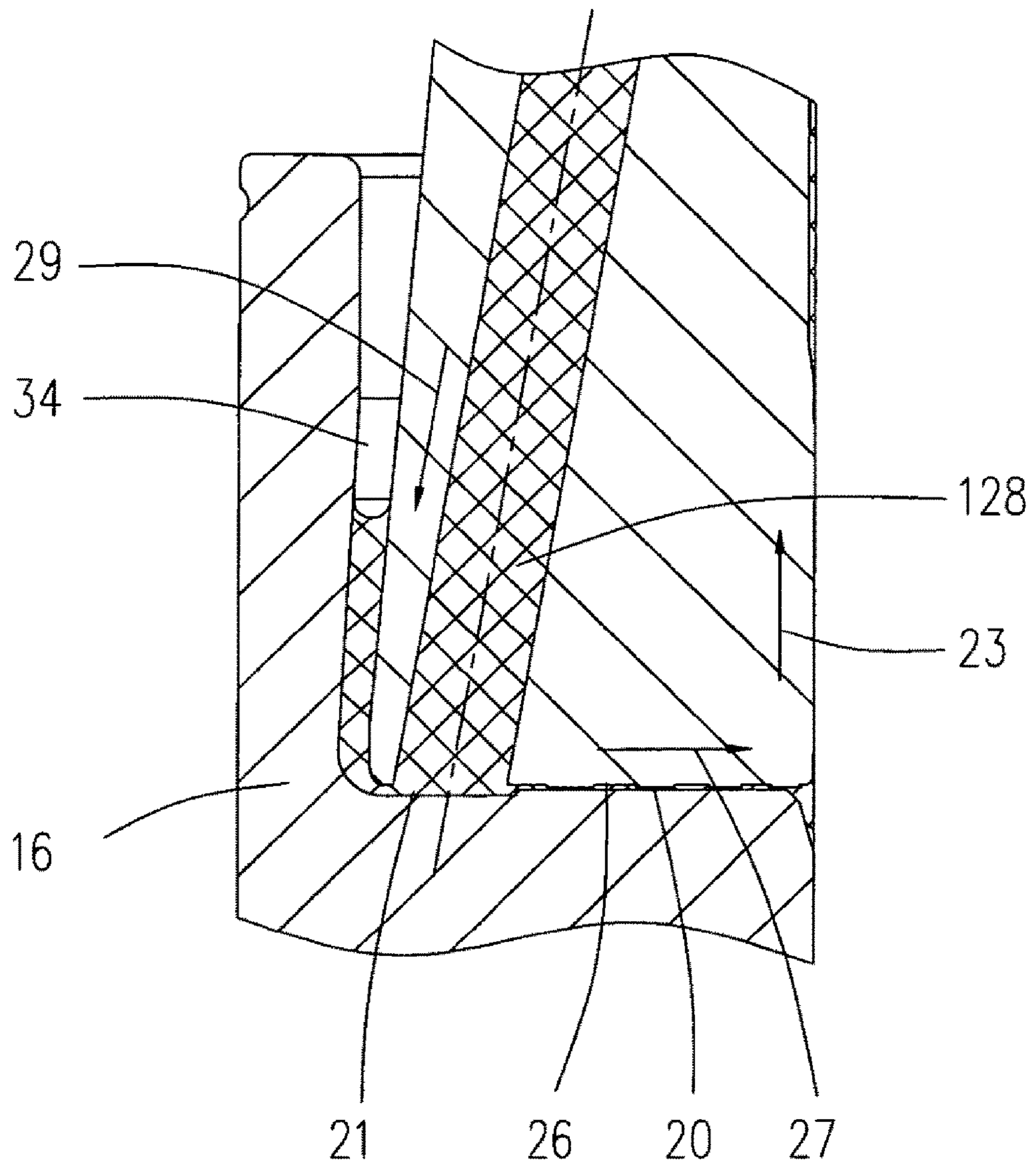
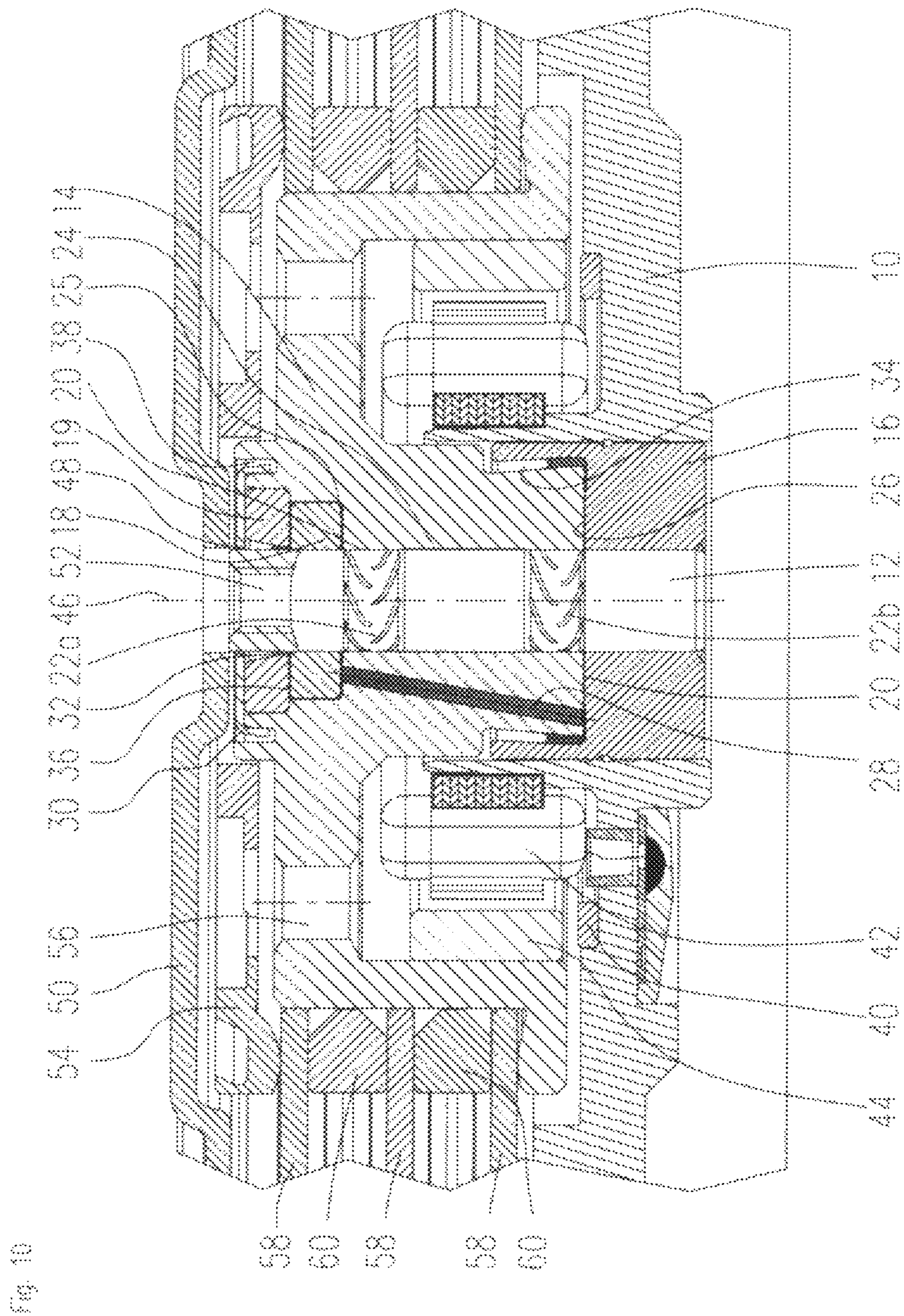

Fig. 9





**SPINDLE MOTOR HAVING A FLUID
DYNAMIC BEARING SYSTEM AND A
STATIONARY SHAFT**

Matter enclosed in heavy brackets [] appears in the original patent but forms no part of this reissue specification; matter printed in italics indicates the additions made by reissue; a claim printed with strikethrough indicates that the claim was canceled, disclaimed, or held invalid by a prior post-patent action or proceeding.

This application is a continuation reissue of application Ser. No. 13/945,043, filed on Jul. 18, 2013, which is an application for reissue of U.S. Pat. No. 7,982,349, based on application Ser. No. 12/313,898 filed Nov. 25, 2008, and notice is hereby given under 37 CFR §1.177 that more than one application for reissue of U.S. Pat. No. 7,982,349 has been filed, namely: (1) reissue application Ser. No. 13/945,043 (filed on Jul. 18, 2013), (2) the instant first continuation reissue application Ser. No. 13/946,142 (filed on Jul. 19, 2013 as a continuation of reissue application Ser. No. 13/945,043), and (3) second continuation reissue application Ser. No. 13/946,244 (filed on Jul. 19, 2013 as a continuation of reissue application Ser. No. 13/945,043).

BACKGROUND OF THE INVENTION

The invention relates to a spindle motor having a fluid dynamic bearing system and a stationary shaft.

DESCRIPTION OF PRIOR ART

Spindle motors having a fluid dynamic bearing system are used, for example, for driving hard disk drives and can generally be divided into two different groups, that is to say designs: motors having a rotating shaft and a bearing system usually open at only one end (e.g. a single plate design) and motors having a stationary shaft. An important advantage afforded by spindle motors having a stationary shaft is the possibility of fastening the shaft at each end, to the baseplate and to the motor housing respectively. This gives these kinds of motors significantly greater structural stiffness making them particularly suitable, for example, for hard disk drives that have increased or special requirements, as occur nowadays for many mobile applications with ever increasing data densities along with vibrations occurring during normal operation. Another important area of application is in hard disk drives that require a particularly low level of operating noise, where greater structural stiffness can especially reduce the transmission and radiation of vibrations generated by the electromagnetic forces of the motor.

In order to prevent bearing fluid from leaking out of the bearing, the construction, and particularly the sealing, of a spindle motor having a stationary shaft and a fluid dynamic bearing system open at both ends are usually more complex than for a spindle motor having a rotating shaft. For a bearing gap open at both ends, there is moreover an increased risk of air penetrating into the bearing gap and impairing the function of the bearing system. Measures have therefore to be taken to prevent air from penetrating into the bearing gap and/or to transport air out of the bearing gap or out of the bearing fluid respectively.

SUMMARY OF THE INVENTION

It is the object of the invention to provide a spindle motor that contains a fluid dynamic bearing system having a

stationary shaft fixed at both ends and that consists of only a few parts that are relatively easy to manufacture. Another object is to facilitate the discharge of any air bubbles found in the bearing gap.

This object is achieved by providing a spindle motor according to the invention which comprises a stationary shaft that is held in a baseplate, either directly or indirectly using an additional flange member, a rotor component supported rotatably about a rotational axis with respect to the shaft, a bearing gap open at both ends that is filled with a bearing fluid and that separates the adjoining surfaces of the shaft, the rotor component and at least one first bearing part from one another, a first radial bearing and a second radial bearing formed between the opposing axially extending bearing surfaces of the shaft and the rotor component, an axial bearing formed between the opposing radially extending bearing surfaces of the rotor component and the first bearing part connected to the baseplate, a recirculation channel filled with bearing fluid that connects the remote regions of the bearing to each other and an electromagnetic drive system for driving the rotor component.

The invention also claims for a hard disk drive comprising such a spindle motor for rotatably driving at least one storage disk.

Preferred embodiments and further advantageous characteristics of the invention are revealed in the dependent claims.

In a preferred embodiment of the invention, the bearing system comprises a total of only four mechanical components, three of the components being stationary components and only one rotating, mechanical rotor component taking the form of a hub/bearing bush arrangement being provided. Such a small number of parts makes the bearing system very simple to construct and in particular makes it possible to manufacture the parts relatively easily and at low cost and to machine them with low tolerance. It is possible to reduce the number of parts still further by forming one of the two bearing parts integrally with the shaft.

According to the invention, various sealing concepts are provided for sealing the bearing gap that is open at both ends. In one concept, the rotor component can have surfaces fashioned such that they form a capillary gap seal together with the surfaces of a bearing part. The gap seal can be formed between an inner circumferential surface of the rotor component and an outer circumferential surface of the respective bearing part. Conversely, it is also possible for the gap seal to be formed between an outer circumferential surface of the rotor component and an inner circumferential surface of the bearing part. Depending on the design and space situation in the bearing, the gap seal may be aligned vertically or horizontally to the rotational axis. In the case of spindle motors for high rotational speeds, it is preferable if the capillary seal is disposed vertically so that the centrifugal forces acting on the bearing fluid exert less influence on the bearing fluid in the capillary seal.

Ideally, the walls defining the capillary seals are slanted so that the capillary seal narrows in the direction of the bearing gap and that the center line of the sealing gap extending in the direction of the bearing gap has an increasingly large spacing to the rotational axis in a radial direction, so that the fluid pressure in the bearing fluid increases due to the centrifugal force that acts in the direction of the bearing gap.

Optionally, the gap seal can be augmented by a dynamic pumping seal which is formed between the opposing radially extending surfaces of the rotor component and a second bearing part connected to the shaft. The surfaces of the rotor component and of a bearing part forming the seal having

3

appropriate pumping patterns that, on rotation of the bearing, generate a pumping effect on the bearing fluid directed towards the interior of the bearing and that compensate any counter pressure of all the bearing patterns thus preventing bearing oil from leaking out of the bearing gap, despite the adjacent gap seal or capillary seal respectively having a comparatively short overall axial length.

To allow bearing fluid to circulate in the fluid bearing, the rotor component comprises a recirculation channel which connects the radially extending sections of the bearing gap or sealing gaps to each other. The recirculation channel is preferably disposed such that it connects the sealing gap radially outside the axial bearing to a section of the bearing gap located radially within the upper sealing gap or the dynamic pumping seal. In this case, the recirculation channel is inclined, i.e. not parallel, to the rotational axis. Using the recirculation channel, the sealing gap radially outside the axial bearing can also be connected to a section of the bearing gap located radially outside the dynamic pumping seal.

In a preferred embodiment of the invention, the recirculation channel is inclined at an acute angle to the rotational axis. Due to the inclined recirculation channel a centrifugal force is exerted on the bearing fluid when the rotor component is in rotation. The centrifugal force within the recirculation channel accelerates the bearing fluid in the same direction as does the overall pumping force which is generated by the axial bearing and the two radial bearings. The pumping force generated by the centrifugal force is directed towards the axial bearing and preferably twice as strong as the overall pumping force exerted on the bearing fluid in the same direction and generated by the axial bearing and the two radial bearings.

In one embodiment of the invention, the surfaces of the rotor component and the bearing part, which form the capillary seal, are preferably parallel to the rotational axis or inclined at an acute angle to the rotational axis. The respective angles of the surfaces defining the capillary gap have to differ in size, thus producing a capillary seal having a tapered cross-section.

One embodiment of the invention provides for the capillary seal to be covered by an annular cover connected to the rotor component, the annular cover forming a labyrinth seal together with a bearing part. This goes to improve the reliability that bearing fluid will not leak out of the capillary seal. The annular cover may of course also be disposed on the bearing part.

According to another embodiment of the invention, the cover may be so formed and fixed onto or into the rotor component that its inside circumference, together with an outside circumference of the associated bearing part, defines the sealing gap of the capillary seal.

The invention will now be described in more detail on the basis of three embodiments with reference to the drawings. Further advantages and characteristics of the invention can be derived from the following description.

BRIEF DESCRIPTION OF THE DRAWINGS

FIG. 1 shows a section through a first embodiment of the spindle motor according to the invention.

FIG. 2 shows a section through a second embodiment of the spindle motor according to the invention.

FIG. 3 shows a section through a third embodiment of the spindle motor according to the invention.

FIG. 4 shows a section through a fourth embodiment of the spindle motor according to the invention.

4

FIG. 5 shows a section through a fifth embodiment of the spindle motor according to the invention.

FIG. 6 shows a section through a sixth embodiment of the spindle motor according to the invention.

FIG. 7 shows a section through a seventh embodiment of the spindle motor according to the invention.

FIG. 8 shows a section through an eighth embodiment of the spindle motor according to the invention.

FIG. 9 shows an enlarged view of the end region of the recirculation channel located radially outside the axial bearing.

FIG. 10 shows a section through a ninth embodiment of the spindle motor according to the invention.

DESCRIPTION OF PREFERRED EMBODIMENTS OF THE INVENTION

FIGS. 1 and 2 show two embodiments of a spindle motor according to the invention that essentially have the same basic construction. The spindle motors could be used for driving the storage disks of a hard disk drive.

The spindle motor according to FIG. 1 comprises a baseplate 10 that has a substantially central cylindrical opening in which a first bearing part 16 is accommodated. The first bearing part 16 is approximately cup-shaped in form and comprises a central opening in which the shaft 12 is fixed. A second bearing part 18 is disposed at an upper end of the stationary shaft 12, the second bearing part 18 being preferably annular in shape and formed integrally with the shaft 12. The said components 10, 12, 16 and 18 form the stationary components of the bearing system of the spindle motor. The shaft 12 has a tapped hole 52 at its upper end for the purpose of fixing it to a housing cover 50 of the spindle motor or of the hard disk drive respectively. The spindle motor comprises a single-piece rotor component 14 that is disposed in a space formed by the shaft 12 and the two bearing parts 16, 18, rotatable with respect to these components. The rotor component is approximately U-shaped in cross-section. The upper bearing part 18 lies in an annular recess in the rotor component 14. Adjoining surfaces of the shaft 12, the rotor component 14 and the bearing parts 16, 18 are separated from one another by a bearing gap 20 open at both ends that is filled with a bearing fluid, such as bearing oil. The electromagnetic drive system of the spindle motor is formed in a well-known manner by a stator arrangement 42 disposed on the baseplate 10 and an annular permanent magnet 44 enclosing the stator arrangement at a spacing, the permanent magnet being disposed on an inner circumferential surface of the rotor component 14.

The rotor component 14 of the spindle motor has a hollow cylindrical section that is designed in such a way that its inside circumference forms two cylindrical bearing surfaces that are separated by a circumferential groove 24 in between. These bearing surfaces enclose the stationary shaft 12 at a distance of only a few micrometers while forming the bearing gap 20 and are provided with suitable grooved patterns, so that, together with the respective opposing bearing surfaces of the shaft 12, they form two fluid dynamic radial bearings 22a and 22b.

A radially extending section of the bearing gap 20 adjoins the lower radial bearing 22b, the radially extending section of the bearing gap being formed by radially extending bearing surfaces of the rotor component 14 and corresponding opposing bearing surfaces of the bearing part 16. These bearing surfaces form a fluid dynamic axial bearing 26 having bearing surfaces taking the form of circular rings perpendicular to the rotational axis 46. The fluid dynamic

5

axial bearing **26** is marked in a well-known manner by spiral-shaped grooved patterns that may be provided either on the rotor component **14**, on the bearing part **16** or on both parts. The grooved patterns of the axial bearing **26** preferably extend over the entire end face of the rotor component, i.e. from the inside rim to the outer rim. This goes to produce a defined distribution of pressure in the entire axial bearing gap and negative pressure zones are avoided since fluid pressure continuously increases from a radially outer to a radially inner position of the axial bearing. Due to this radially-outwards declining pressure gradient, any gases contained in the bearing fluid are transported radially outwards. All the grooved patterns needed for the radial bearings **22a**, **22b** and for the axial bearing **26** are advantageously disposed on the rotor component **14**, which goes to simplify the manufacture of the bearing, particularly the shaft **12** and the bearing part **16**, since all the patterns can be made in a single operation.

A sealing gap **34** proportionally filled with bearing fluid adjoins the radial section of the bearing gap **20** in the region of the axial bearing **26**, the sealing gap **34** being formed by the opposing surfaces of the rotor component **14** and the bearing part **16** and sealing the end of the fluid bearing system on this side. The sealing gap **34** comprises a radially extending section wider than the bearing gap **20** that merges into a tapered section extending almost axially which is defined by an outer circumferential surface of the rotor component **14** and an inner circumferential surface of the bearing part **16**. Alongside its function as a capillary seal, the sealing gap **34** acts as a fluid reservoir, making available the amount of fluid necessary for the useful life of the bearing system after fluid is lost from the bearing gap by evaporation. Moreover, filling tolerances and any thermal expansion of the bearing fluid can be compensated. The two surfaces on the rotor component **14** and the bearing part **16** forming the tapered section of the sealing gap **34** may each be inclined inwards with respect to the rotational axis **46**. On rotation of the bearing, this causes the bearing fluid to be pressed towards the interior in the direction of the bearing gap **20** due to the centrifugal force.

At the other end of the fluid bearing system, the rotor component **14** adjoining the upper radial bearing **22a** is designed such that it forms a radially extending surface that, together with a corresponding opposing surface of the bearing part **18**, forms a narrow gap whose width is wider than the width of the bearing gap **20** in the region of the radial bearing. In the region of this gap, a dynamic pumping seal **36** can optionally be disposed that is marked by suitable pumping patterns taking the form of spiral grooves on the surfaces of the rotor component **14**, the bearing part **18** or both, and seals the fluid bearing system at this end. The pumping seal **36** widens at the outer end and leads into a sealing gap **32** preferably having a tapered cross-section. The sealing gap **32** extends substantially axially and is defined by the opposing surfaces of the rotor component **14** and the bearing part **18** that are preferably inclined inwards with respect to the rotational axis **46**. On rotation of the bearing, this causes the bearing fluid to be pressed towards the interior in the direction of the bearing gap **20** due to the centrifugal force. The sealing gap **32** may be covered by an annular cover **30**. The cover **30** is held in an annular groove **38** in the rotor component **14** and bonded in place, for example. Together with the end of the shaft **12**, the cover **30** forms a labyrinth seal **48**, by means of which the exchange with air and thus the evaporation of bearing fluid is reduced. This goes to improve the reliability that bearing fluid will not leak out of the sealing gap **32**. The annular cover may also

6

of course be disposed on the shaft **12** and form a labyrinth seal with the rotor component **14**.

In order to fulfill the described functions and to ensure a simple motor assembly, the two bearing parts **16**, **18**, which are fixedly connected to the shaft **12** by means, for example, of an integral design or by pressing, bonding or welding, must of course be suitably designed. It may be particularly favorable to design one of the two bearing parts, part **16** for example, to be cup-shaped with a raised rim, so that, together with an opposing surface of the rotor component **14**, it forms a sealing gap **34** of a capillary gap seal at its inner circumferential surface, and at the outside circumference it can be connected to the baseplate **10**. On the other hand, the simplest possible design for the bearing parts **16**, **18** may be advantageous, such as a chamfered or even a straight circular disk, like bearing part **18** for example.

To ensure continuous flushing of the bearing system with bearing fluid, the rotor component **14** is provided with a recirculation channel **28**. The recirculation channel **28** connects the radial section of the sealing gap **34** located radially outside the axial bearing **26** to a radially extending section of the bearing gap radially within the dynamic pumping seal **36**, i.e. the section of the bearing gap between the pumping seal **36** and the first radial bearing **22a**. The recirculation channel **28** can be easily realized, for example, by drilling through the rotor component **14** at an angle to the rotational axis **46** of the motor. In doing so, the recirculation channel **28** is inclined at an angle of approximately 10 degrees to the rotational axis **46**. The upper end of the recirculation channel **28** lies radially within the pumping seal **36**. This means that in the region of the opening of the recirculation channel **28** higher pressure prevails than, for example, in the sealing gap **32**, so that any air bubbles found in the bearing gap in the region of the opening of the recirculation channel **28** are transported radially outwards due to the falling pressure gradient, whereas the bearing fluid is transported radially inwards due to the effect of the pumping seal **36**. The inclined arrangement of the recirculation channel **28** and the different pressure conditions at the opposing ends of the recirculation channel **28** favor the discharge of air bubbles out of the bearing fluid.

The radial bearings each consist of a number of half-sine-shaped bearing grooves that pump the bearing fluid axially upwards or downwards respectively. Due to the varying lengths of the bearing grooves, asymmetric shaped radial bearings are produced that have an overall pumping direction, which, even in the case of a bearing bore that, due to manufacturing tolerances, deviates from a cylindrical shape and is slightly tapered in the region of the radial bearing gap, is always directed axially upwards in the direction of the second bearing part **18**. The axial bearing **26** preferably has spiral-shaped bearing grooves that pump the bearing fluid radially inwards. When the bearing is in operation, centrifugal forces act on the bearing fluid found within the recirculation channel, so that it is pressed axially downwards thus producing a recirculation of bearing fluid within the fluid bearing.

Since the entire rotor of the spindle motor (apart from magnet **44** and a cover **30** where applicable) preferably consists of only the rotor component **14**, the position tolerance with respect to the fluid bearing of the rotor surfaces, which act, for example, as supporting surfaces for the storage disks of a hard disk drive, is better than for a rotor consisting of several parts, and the mechanical stability is considerably greater. Moreover, the functional surfaces (bearing surfaces) of the fluid bearing system, all of which are located on one part, preferably the rotor component **14**,

can be relatively easily manufactured to the required precision. In particular, compared, for example, to a considerably smaller bearing bush of a conventional design, the rotor component **14** can be relatively easily clamped into a chuck and the final processing of almost all the bearing surfaces can be carried out without having to rechuck. What is more, it is now possible to dispense with the assembly of the rotor from several separate parts, which is difficult particularly for small form factors and inevitably associated with stoppages, and where the separate parts together have to incorporate all the functional surfaces necessary for a fluid bearing system with the required precision and additional, specially designed close-tolerance connecting regions.

Because the bearing is mounted in the first bearing part **16**, which acts as a flange for connection to the baseplate **10**, it is possible to mount the fluid bearing as a structural unit, to fill it with bearing fluid and to test it before the fluid bearing is connected as a structural unit to the baseplate **10**.

Since the spindle motor has only one fluid dynamic axial bearing **26** that generates a force in the direction of the second bearing part **18**, a corresponding counterforce or preload force has to be provided that holds the bearing system in axial balance. For this purpose, the baseplate **10** may have a ferromagnetic ring **40** that lies axially opposite the rotor magnet **44** and is magnetically attracted by the rotor magnet. This magnetic force of attraction acts in opposition to the force of the axial bearing **26** and keeps the bearing axially stable.

As an alternative or in addition to this solution, the stator arrangement **42** and the rotor magnet **44** may be disposed at an axial offset with respect to one another in such a way that the rotor magnet **44** is disposed axially further away from the baseplate **10** than the stator arrangement **42**. Through the magnetic system of the motor, an axial force is thereby built up that acts in the opposite direction to the axial bearing **26**.

The outer cup-shaped part of the rotor component **14** is provided for the purpose of attaching the storage disks **58** of the hard disk drive. The annular disk-shaped storage disks **58** rest on a lower, radially outwards aligned collar of the rotor component **14** and are separated from one another by spacers **60**. The storage disks **58** are held by a holding piece **54** that is fixed by means of screws in tapped holes **56** in the rotor component **14**.

In FIG. **2** a spindle motor is illustrated in which identical components or components having the same functions as those in FIG. **1** are provided with the same reference numbers. The spindle motor according to FIG. **2** essentially differs from the spindle motor according to FIG. **1** by having a two-piece rotor component and a different design for the upper seal. Substantially the same description applies to FIG. **2** as for the spindle motor in FIG. **1**.

In FIG. **2**, the rotor component **114** is formed in two pieces and comprises an inner, approximately cylindrical rotor component **114a** and an outer approximately cup-shaped rotor component **114b**. The inner rotor component **114a** encloses the shaft **12** and, together with the shaft, forms the two radial bearings **22a**, **22b**. An end face of the inner rotor component **114a** lies opposite a radial surface of the first bearing part **16** and, together with the first bearing part **16**, forms the axial bearing **26**. The dynamic pumping seal **36** is formed by an end face of the inner rotor component **114a** and an opposing surface of the second bearing part **18**, at least one of the two surfaces being provided with pumping patterns. Outside the pumping seal **36**, the sealing gap **32** adjoins, which is defined by an inner circumferential surface of a cup-shaped cover **130** and an outer, chamfered circumferential surface of the second bearing part **18**. The cover

130 is mounted on the end face of the inner rotor component **114a** and welded, for example, to this component. An annular labyrinth gap **48** remains between an inside edge of the cover **130** and the bearing part **18** (or the shaft **12** respectively), the labyrinth gap additionally sealing the capillary seal towards the outside.

The sealing gap **34** adjoining the axial bearing **26** is defined by the outside circumference of the inner rotor component **114a** and the inside circumference of the cup-shaped first bearing part **16**. The recirculation channel **128** extends within the inner rotor component **114a** and connects the sealing gap **34** in the region of the outside diameter of the axial bearing **26** to a section of the bearing gap radially within the pumping seal **36**. The recirculation channel **128** is inclined at an angle of approximately 10 degrees with respect to the rotational axis **46**.

The inner rotor component **114a** takes on the function of a bearing bush and the outer, cup-shaped rotor component **114b** has the function of a hub that carries the magnet **44** of the drive system and the components to be driven, such as the storage disks **58**, as described in conjunction with FIG. **1**.

FIG. **3** shows an enlarged section through a bearing system of a spindle motor according to the invention. In this embodiment, the shaft **212** and the first bearing part **216** are integrally formed as one piece. The rotor component **214** is disposed rotatable about the rotational axis **246** in an annular space formed by the shaft **212** and the first bearing part **216**. The first bearing part **216** is fixedly connected at its outside circumference to the base **210** of the motor. Two radial bearings **222a**, **222b** are disposed between bearing surfaces on the inside circumference of the rotor component **214** and on the outside circumference of the shaft **212** and separated from one another by an axial section of the bearing gap **220**. An axial bearing **226** is disposed along a radial section of the bearing gap **220**, the axial bearing being formed by bearing surfaces on the end face of the rotor component **214** or on a bottom surface of the first bearing part **216** respectively. The axial section of the bearing gap **220** merges into a sealing gap **232** that has a radially extending section and an axially extending section and is defined by surfaces of a second bearing part **218** disposed on the shaft **212** and the opposing surfaces of the rotor component **214**.

The sealing gap **232** is partially filled with bearing fluid and forms a tapered gap seal. A cover to cover the sealing gap and to restrain the bearing fluid is not provided here. In the region of the sealing gap **232**, one or more pumping seals **236** or **237** may be disposed that are located in the horizontally or in the vertically extending gap between the second bearing part **218** and the respective opposing surface of the rotor component **214** and that transport the bearing fluid found in the sealing gap **232** towards the interior in the direction of the axial section of the bearing gap **220**. Another sealing gap **234**, which additionally acts as a fluid reservoir, is provided adjoining the radial section of the bearing gap **220**. The sealing gap **234** is part of a gap that is defined by the outside diameter of the cylindrical part of the rotor component **214** and the inside diameter of the first bearing part **216**. A recirculation channel **228** is provided in the rotor component **214**, the recirculation channel connecting the respective open ends of the bearing gap **220** to each other. This embodiment of the spindle motor is characterized by the small number of necessary components. The other components of the spindle motor, such as the drive system and the holding piece for the storage disks, are not illustrated in FIG. **3**.

The recirculation channel is preferably inclined by 5-15 degrees with respect to the rotational axis. Alternatively, the recirculation channel can also be aligned largely parallel to the rotational axis **46**. The bearing grooves of the axial bearing **26**, **226** preferably run from the radially inner bearing bore to the radially outer region of the capillary seal **34**. Both the axial bearing patterns **26**, **226** as well as the pumping patterns of the pumping seals **36**, **236**, **237** are preferably formed on the surface of the rotor component **14**, **114a**, **214**. The pumping patterns of the pumping seals **36**, **236** extend in a radial direction again preferably from the radially inner region of the bearing bore next to the shaft to the region of the sealing gap **32**, **232**. In addition or as an alternative, an axially extending pumping seal **237** may be disposed in the region of the sealing gap **232**, as illustrated in FIG. 3.

FIG. 4 shows a further embodiment of a spindle motor according to the invention having a baseplate **310** in which a first bearing part **316** is accommodated. The first bearing part **316** comprises a central opening in which a shaft **312** is fixed. The shaft **312** has a step that acts as a stopper and rests on the surface of the bearing part **316**. The step enables the axial distance between the two bearing parts **316** and **318** to be very precisely and reproducibly adjusted. At an upper end of the stationary shaft **312**, a second bearing part **318** is disposed that is preferably integrally formed with the shaft **312** as one piece. The spindle motor comprises a multipart rotor component that has an inner rotor component **314a** which is disposed in a space formed by the shaft **312** and the two bearing parts **316**, **318**, rotatable with respect to the shaft. The upper bearing part **318** is accommodated in an annular recess in the rotor component **314a**. Adjoining surfaces of the shaft **312**, the rotor component **314a** and the bearing parts **316**, **318** are separated from one another by a bearing gap open at both ends **320** that is filled with a bearing fluid, such as bearing oil. The rotor component **314a** is enclosed by an outer, cup-shaped rotor component **314b** that carries at its inside circumference an annular permanent magnet **344** forming part of the electromagnetic drive system. A stator arrangement **342** is disposed on the baseplate **310**, the stator arrangement lying opposite the permanent magnet **344**.

The inner rotor component **314a** has a hollow cylindrical bore at whose inside circumference two cylindrical bearing surfaces are formed that are separated by a circumferential groove **324** lying in between. These bearing surfaces enclose the stationary shaft **312** at a distance of only a few micrometers while forming the bearing gap **320** and are provided with grooved patterns, so that together with the respective opposing bearing surfaces of the shaft **312**, they form two fluid dynamic radial bearings **322a** and **322b**.

A radially extending section of the bearing gap **320** adjoins the bearing gap in the region of the lower radial bearing **322b**, the radially extending section of the bearing gap **320** separating the radially extending bearing surfaces of the rotor component **314a** and the corresponding opposing bearing surfaces of the bearing part **316** from one another. The bearing surfaces of the above-mentioned components form a fluid dynamic axial bearing **326** that is marked in a well-known manner by spiral-shaped grooved patterns that are formed on one or both bearing surfaces.

A sealing gap **334** proportionally filled with bearing fluid adjoins the radial section of the bearing gap **320** in the region of the axial bearing **326**, the sealing gap **334** being formed by opposing surfaces of the rotor component **314a** and the bearing part **316** and sealing the lower end of the bearing gap. The sealing gap **334** comprises a radially extending

section wider than the bearing gap **320** that merges into a tapered, almost axially extending section that is defined by an outer circumferential surface of the rotor component **314a** and an inner circumferential surface of the bearing part **316**. The sealing gap **334** further acts as a fluid reservoir and serves to compensate filling tolerances, loss of bearing fluid through evaporation and thermal expansion of the bearing fluid.

The rotor component **314a** at the other end of the bearing gap **320** is designed such that it forms a radially extending surface that, together with a corresponding opposing surface of the bearing part **318**, forms a narrow gap whose width is wider than the width of the bearing gap **320** in the region of the radial bearing. In the region of this gap, a dynamic pumping seal **336** is provided that is marked by suitable pumping patterns taking the form of spiral grooves on the surfaces of the rotor component **314a** or the bearing part **318** respectively and that seals the fluid bearing system at this end of the bearing gap. On the other side of the pumping seal **336**, a sealing gap **332** having a tapered cross-section is provided that extends substantially axially and is defined by the surfaces of the rotor component **314a** and the bearing part **318**. The sealing gap **332** is covered by an annular cover **330** that is formed as part of the outer rotor component **314b**. Together with an end face of the bearing part **318**, the cover **330** forms a labyrinth seal **348** to provide an additional seal for the sealing gap **332**.

To ensure continuous flushing of the bearing system with bearing fluid, a recirculation channel **328**, such as an axial bore, is disposed in the rotor component **314a**. The recirculation channel **328** connects a section of the sealing gap **334** radially outside the axial bearing **326** to a radially extending section of the bearing gap radially outside the dynamic pumping seal **336**.

Since the spindle motor has only one fluid dynamic axial bearing **326** that exerts a force in the direction of the second bearing part **318**, a corresponding counterforce or preload force has to be provided that keeps the bearing system in axial balance. For this purpose, a ferromagnetic ring **340** is disposed on the baseplate **310**, the ferromagnetic ring **340** lying axially opposite the rotor magnet **344** axial and being magnetically attracted by the rotor magnet **344**. This magnetic force of attraction acts in opposition to the force of the axial bearing **326** and keeps the bearing axially in balance.

In FIG. 5, a modified embodiment of the spindle motor is shown that differs in various ways from the spindle motor in FIG. 4.

The first way in which it differs from the spindle motor in FIG. 4 is that the rotor component consists of three parts: an inner, sleeve-shaped rotor component **314a**, a similarly sleeve-shaped rotor component **314c** enclosing the first component **314a** and the outer rotor component **314b**. The inner rotor component illustrated in FIG. 4 is basically formed in two pieces and consists of the components **314a** and **314c**. The recirculation channel **328** is formed between the two rotor components **314a** and **314c**, taking the form, for example, of a channel-shaped groove at the outside circumference of component **314a** or at the inside circumference of component **314c**.

Another difference is in the design of the shaft **312** that no longer has a step in the region of the lower bearing part **316**, but rather is perfectly cylindrical.

The upper sealing gap **332** that extends between an inside circumference of the rotor component **314c** and an outside circumference of the bearing part **318** is covered by a cover **330**, which, however, is formed as a separate, annular component. The cover **330** is fixed to the rotor component

314c or the outer rotor component 314b respectively. A capillary seal 348 is formed between the cover 330 and the end face of the bearing part 318, just as in the embodiment according to FIG. 4.

A further important difference in the bearing of FIG. 5 is that instead of an upper pumping seal a second axial bearing 327 is now provided. This axial bearing 327 is formed by an end face of the rotor component 314a and an opposing bearing surface of the bearing part 318. The axial bearing is marked by grooved patterns and forms a counter bearing to the lower axial bearing 326. The two axial bearing 326 and 327 operate in opposition to one another and keep the bearing in axial balance, making a magnetic preload, as provided in FIG. 4, no longer necessary.

FIG. 6 shows an embodiment of a spindle motor that is very similar to the embodiment of FIG. 4. The first difference between the spindle motor according to FIG. 6 and the spindle motor according to FIG. 4 is that the recirculation channel 328 is not made parallel to the rotational axis 346, but rather inclined at an angle of approximately 5 degrees to the rotational axis 346. The recirculation channel 328 thus connects a region of the lower sealing gap 334 to a radially extending region of the bearing gap radially outside an upper fluid dynamic axial bearing 327. The fluid dynamic axial bearing 327 acts in opposition to the lower fluid dynamic axial bearing 326 and constitutes a second difference to the spindle motor according to FIG. 4 in which only a lower fluid dynamic axial bearing was provided. Due to the two fluid dynamic axial bearings 326 and 327, no magnetic preload is necessary for the spindle motor according to FIG. 6.

FIG. 7 shows a spindle motor that is likewise very similar to the spindle motor of FIG. 4. The spindle motor according to FIG. 7 comprises a greatly widened lower shaft end having a large diameter, which is inserted into the lower bearing part 316. The wider foot end of the shaft ensures greater stiffness. The inner end face of the widened section of the shaft 312 together with an end face of the rotor component 314a now forms the axial bearing 326 as well as parts of the radial section of the sealing gap 334. Moreover, the upper bearing part 318 is not formed integrally with the shaft, but rather as an annular part fixed separately to the end of the shaft 312. In contrast to the spindle motor of FIG. 6, for example, no upper axial bearing is provided but rather the sealing effect of the sealing gap 332 in this region is supported by a pumping seal 336 that is disposed between the end face of the rotor component 314a and of the bearing part 318.

A magnetic preload that acts in the opposite direction to the force of the axial bearing 326 is generated by a ferromagnetic ring 340 that lies opposite the rotor magnet 344 and attracted by this magnet.

FIG. 8 shows a section through a spindle motor whose construction corresponds substantially to the spindle motor of FIG. 2. Thus the basic description of the spindle motors of FIGS. 1 and 2 applies to the spindle motor of FIG. 8, identical components or components having the same functions being indicated by the same reference numbers.

As in the spindle motor of FIG. 2, a bearing part 18 is also disposed at the upper end of the shaft 12 that is formed integrally with the shaft 12 as one piece. Moreover, a pumping seal 136 for sealing the sealing gap 32 is provided that is disposed between an outside circumference of the bearing part 18 and an inside circumference of a recess in the bearing bush 114a. The pumping patterns of the pumping seal 136 that pumps in an axial direction into the interior of the bearing are preferably disposed on the inside circumfer-

ence of the bearing bush 114a. Because the pumping seal 136 is disposed between axially extending surfaces, the diameter of the bearing part 18 can be decreased, by means of which the diameter of the annular gap between the underside of the bearing part 18 and an opposing surface of the bearing bush 114a is also decreased.

A recirculation channel 128 is provided in the bearing bush 114a, the recirculation channel 128 starting at the radially extending annular gap between the underside of the bearing part 18 and an opposing surface of the bearing bush 114a runs at an angle of approximately 10 degrees to the rotational axis 46 and connects the topside of the bearing to the underside and leads into a radially outer region of the lower axial bearing 26. The recirculation channel 128 thus ends outside the axial bearing gap 20 between the axial bearing gap 20 and the sealing gap 34.

The mouth region of the recirculation channel 128 is illustrated in FIG. 9 in an enlarged view. It can be seen that the recirculation channel 128 ends radially outside the bearing gap 20 of the axial bearing 26. In the mouth region of the recirculation channel 128, the bearing gap 20 widens to form a gap 21 which then merges radially outwards into the sealing gap 34. Due to the inclined arrangement of the recirculation channel 128 in the rotating bearing part 114a, a centrifugal force is exerted on the bearing fluid found in the recirculation channel 128. This centrifugal force transports the bearing fluid in the direction of arrow 29, i.e. starting from the axial gap in the region of the upper bearing part 18 through the recirculation channel 128 to gap 21 in the region of the lower bearing part 16. Gap 21 has a larger gap width than the bearing gap 20, so as to allow the bearing fluid to flow unimpeded out of the recirculation channel 128. The axial bearing 26 has bearing patterns that transport the bearing fluid in the direction of the shaft 12 in the direction shown by arrow 27. The radial bearings 22a and 22b generate an overall pumping effect upwards in the direction of arrow 23 to bearing part 18, by means of which the bearing fluid is then transported to the opening in the recirculation channel 128 where the cycle starts over again. The bearing fluid thus flows in the recirculation channel 128 in the same direction as the net pumping direction of the bearing, i.e. of the axial bearing 26 and the two radial bearings 22a, 22b. The pumping seal 136 lies outside this cycle and pumps into the interior of the bearing in the direction of the recirculation channel 128.

The lower radial bearing 22b is made distinctly asymmetric and all in all pumps the bearing fluid upwards, whereas the upper radial bearing 22a is made symmetric or slightly asymmetric.

The pumping action on the bearing fluid generated by the centrifugal force within the recirculation channel is preferably substantially larger than the overall pumping action on the bearing fluid in the same direction generated by the thrust bearing and the two radial bearings. Because of the relatively large pumping action generated by the inclined recirculation channel, a directed pumping action generated by the axial bearing or the two radial bearings may not be necessary to maintain circulation of the bearing fluid within the bearing gap. In this case, the thrust bearing and/or the two radial bearings can comprise bearing grooves that are almost symmetrical and generate a pumping action of about the same strength in both directions of the bearing gap.

Any air trapped in the bearing fluid that is found within the recirculation channel 128 is transported upwards by the centrifugal effect in the direction of the radial gap located between the bearing bush 114a and the bearing part 18. Due to the continuous increase in pressure brought about by the

13

pumping seal **136** seen from the upper sealing gap **32** in the direction of the interior of the bearing, the air is subsequently forced out of the bearing via the upper sealing gap **32**.

The bearing patterns of the axial bearing **26** are preferably given a spiral shape and formed in the bearing bush **114a**, and extend continuously from the inner bore next to the shaft **12** to the outer rim of the bearing bush **114a**.

A spindle motor as illustrated in FIGS. **8** and **9** is preferably used for driving 2.5 inch hard disk drives. This kind of spindle motor has, for example, a shaft diameter of 2.5 mm and a bearing bush **114a** diameter of approximately 6 mm. The bearing patterns of the axial bearing **26** have a depth, for example, of 15 μm and, when the motor is in operating status, the bearing gap **20** in the region of the axial bearing **26** has a width, for example, of 10 to 15 μm . The width of the axial bearing gap is defined by the fly-height of the bearing. The gap width of the gap **21** in the mouth region of the recirculation channel **128** is, for example, 30 μm .

The gap width of gap **21** is preferably greater than or equal to the fly-height (width of the axial bearing gap in operation) plus the depth of the axial bearing patterns. Thanks to the inclined recirculation channel **128**, the circulation of bearing fluid in the bearing gap is positively supported. This also applies accordingly to the spindle motors illustrated in FIGS. **1-3** and **6**.

FIG. **10** shows a section through a spindle motor whose construction corresponds substantially to the spindle motor of FIG. **1**. Thus the basic description of the spindle motor of FIG. **1** applies to the spindle motor of FIG. **10**, identical components or components having the same functions being indicated by the same reference numbers.

The spindle motor illustrated in FIG. **10** has an upper bearing part **18** disposed on the shaft **12**. The upper bearing part **18**, encircled by the bearing gap **20** filled with bearing fluid, is seated in a recess in the rotor component **14**. Together with an adjoining surface of the rotor component **14**, a lower surface of the bearing part **18** forms an axial bearing **25** that operates in opposition to the axial bearing **26** on the underside of the bearing. The axial bearing **25** is marked by grooved patterns that are disposed on the surface of the bearing part **18** and/or on the corresponding surface of the rotor component **14**. The grooved patterns generate a pumping effect on the bearing fluid in the bearing gap **20** that is directed towards the interior of the bearing, i.e. in the direction of the radial bearings **22a**, **22b**.

A further bearing part **19** adjoins the upper end face of the bearing part **18**, the bearing part **19** being fixedly connected to the rotor component **14**. The two bearing parts **18**, **19** are separated from each other by a radially extending gap in whose course the dynamic pumping seal **36** is disposed. The pumping seal **36** is marked by pumping patterns pumping radially outwards and taking the form of spiral grooves on the surfaces of bearing part **18** and/or bearing part **19** and seals the fluid bearing system at this end. The gap in the region of the pumping seal **36** extends radially inwards, changes its course in an axial direction and merges into an axially extending sealing gap **32** preferably having a tapered cross-section. The sealing gap **32** is defined by the opposing surfaces of the shaft **12** and the bearing part **19**. The sealing gap **32** is located at the smallest diameter of the bearing and may be covered by an annular cover **30**. The cover **30** is held in an annular groove **38** of the rotor component **14** and fixed there, for example, by being bonded, pressed in or (laser) welded. The cover **30**, together with the end of the shaft **12**,

14

forms a labyrinth seal **48**, by means of which the exchange with air and thus the evaporation of bearing fluid is decreased.

IDENTIFICATION REFERENCE LIST

- 5 **10** Baseplate
- 12** Shaft
- 14; 114a, 114b** Rotor component
- 10 **16** First bearing part
- 18** Second bearing part
- 19** Bearing part
- 20** Bearing gap
- 21** Gap
- 15 **22a, 22b** Radial bearing
- 24** Groove
- 25** Axial bearing
- 26** Axial bearing
- 27** Direction of arrow
- 20 **28; 128** Recirculation channel
- 29** Direction of arrow
- 30, 130** Cover
- 32** Sealing gap
- 34** Sealing gap
- 25 **36, 136** Pumping seal
- 38** Annular groove
- 40** Ferromagnetic ring
- 42** Stator arrangement
- 44** Magnet
- 30 **46** Rotational axis
- 48** Labyrinth seal
- 50** Housing cover
- 52** Tapped hole (shaft)
- 54** Holding piece
- 35 **56** Tapped hole (rotor component)
- 58** Storage disks
- 60** Spacer
- 210** Baseplate
- 212** Shaft
- 40 **214** Rotor component
- 216** First bearing part
- 218** Second bearing part
- 220** Bearing gap
- 222a, 222b** Radial bearing
- 45 **226** Axial bearing
- 228** Recirculation channel
- 232** Sealing gap
- 234** Sealing gap
- 236** Pumping seal
- 50 **237** Pumping seal
- 246** Rotational axis
- 310** Baseplate
- 312** Shaft
- 314, 314a, 314b** Rotor component
- 55 **314c** Rotor component
- 316** First bearing part
- 318** Second bearing part
- 320** Bearing gap
- 322a, 322b** Radial bearing
- 60 **324** Groove
- 326** Axial bearing
- 327** Axial bearing
- 328** Recirculation channel
- 330** Cover
- 65 **332** Sealing gap
- 334** Sealing gap
- 336** Pumping seal

340 Ferromagnetic ring
 342 Stator arrangement
 344 Magnet
 346 Rotational axis
 348 Labyrinth seal

The invention claimed is:

[1. A spindle motor having a fluid dynamic bearing system comprising:

a stationary shaft (12; 212; 312) that is held directly or indirectly in a baseplate (10, 210; 310),

a rotor component (14, 114a; 214; 314a-c) rotatably supported with respect to the shaft about a rotational axis (46; 246; 346),

a bearing gap (20, 220; 320) open at both ends filled with a bearing fluid that separates the adjoining surfaces of the shaft (12; 212; 312), the rotor component (14, 114a; 214; 214a-c) and at least one first bearing part (16, 216; 316) from one another, a first radial bearing (22a, 222a; 322a) and a second radial bearing (22b, 222b; 322b) formed between the opposing axially extending bearing surfaces of the shaft (12; 212; 312) and the rotor component (14, 114a; 214; 314a-c),

an axial bearing (26, 226; 326) formed between the opposing radially extending bearing surfaces of the rotor component (14, 114a; 214; 314a-c) and the first bearing part (16, 216; 316) connected to the baseplate,

a recirculation channel (28; 128; 228; 328) filled with bearing fluid that connects the remote regions of the bearing to each other, and

an electromagnetic drive system (42, 44; 342, 244) for driving the rotor component, and

characterized in that the recirculation channel (28, 128; 228) ends in a gap (21) radially outside of the bearing gap (20) of the axial bearing (26), the width of the gap (21) being greater than the width of the bearing gap (20).]

[2. A spindle motor according to claim 1, characterized in that the rotor component consists of an inner, sleeve-shaped rotor component (114a; 314a) and an outer cup-shaped rotor component (144b; 314b).]

[3. A spindle motor according to claim 2, characterized in that the inner, sleeve-shaped rotor component (314a) is enclosed by a further, sleeve-shaped rotor component (314c) on which the outer cup-shaped rotor component (314b) is disposed.]

[4. A spindle motor according to claim 1, characterized in that it only contains one rotating, mechanical rotor component (14; 214) taking the form of a hub/bearing bush arrangement.]

[5. A spindle motor according to claim 1, characterized in that the first bearing part (216) is integrally formed with the shaft (212) as one piece.]

[6. A spindle motor according to claim 1, characterized in that a second bearing part (18; 318) is integrally formed with the shaft (12) as one piece.]

[7. A spindle motor according to claim 1, characterized in that the rotor component (14, 114a; 214; 314a-c) has surfaces that are fashioned such that, together with surfaces of the second bearing part (18; 218; 318), they form a sealing gap (32; 232; 332) of a capillary gap seal.]

[8. A spindle motor according to claim 1, characterized in that the rotor component (14, 114a; 214; 314a-c) has surfaces that are fashioned such that, together with surfaces of a first bearing part (16; 216; 316), they form a sealing gap (34; 234; 334) of a capillary gap seal.]

[9. A spindle motor according to claim 1, characterized in that the recirculation channel (328) is disposed in the rotor

component (314a) or between the rotor components (314a, 314c) and connects the sealing gap (334) radially outside the axial bearing (226) to a section of the bearing gap (320) located radially outside a dynamic pumping seal.]

[10. A spindle motor according to claim 1, characterized in that the recirculation channel (28, 128; 228) is disposed at an incline to the rotational axis (46), which, on rotation of the rotor component, causes a centrifugal force to be exerted on the bearing fluid held in the recirculation channel, the centrifugal force transporting the bearing fluid through the recirculation channel (28, 128; 228) in the direction of arrow (29).]

[11. A spindle motor according to claim 10, characterized in that the recirculation channel (28, 128; 228) is inclined at an angle of 5 to 15 degrees with respect to the rotational axis (46).]

[12. A spindle motor according to claim 10, characterized in that the centrifugal force exerted on the bearing fluid due to the inclined recirculation channel (28, 128; 228) acts in the same direction as a pumping force exerted on the bearing fluid due to an overall pumping effect of the axial bearing (26; 126; 226; 326) and the radial bearings (22a, 22b; 122a, 122b; 222a, 222b; 322a, 322b).]

[13. A spindle motor according to claim 12, characterized in that the pumping force generated by the centrifugal force is directed to the axial bearing (26).]

[14. A spindle motor according to claim 12, characterized in that the centrifugal force is at least twice as big as the force exerted on the bearing fluid due to the overall pumping effect of the axial bearing (26) and the radial bearings (22a, 22b).]

[15. A spindle motor according to claim 1, characterized in that a dynamic pumping seal (36; 236; 336) is formed between opposing radially extending surfaces of the rotor component (14, 114; 214; 314) and a second bearing part (18; 218; 318) connected to the shaft.]

[16. A spindle motor according to claim 15, characterized in that the dynamic pumping seal (36; 236; 336) is formed between a radially extending end face of the rotor component (14, 114a; 214; 314a) and an adjoining radially extending end face of the second bearing part (18; 218; 318).]

[17. A spindle motor according to claim 15, characterized in that the dynamic pumping seal (36; 236; 336) is disposed substantially perpendicular and the sealing gap (32; 232; 332) of the gap seal substantially parallel to the rotational axis (46; 246; 346).]

[18. A spindle motor according to claim 1, characterized in that the baseplate (10; 310) has a ferromagnetic ring (40; 340) that lies axially opposite a rotor magnet (44; 344) of the electromagnetic drive system and is magnetically attracted by this magnet and that they generate a magnetic force that is directed in the opposite direction to a bearing force generated by the axial bearing (26; 326).]

[19. A spindle motor according to claim 18, characterized in that the electromagnetic drive system comprises a stator arrangement (42; 342) which is disposed at an axial offset with respect to the rotor magnet (44; 344) and generate a magnetic force that is directed in the opposite direction to a bearing force generated by the axial bearing (26; 326).]

[20. A spindle motor according to claim 1, characterized in that adjacent surfaces of the second bearing part (18) and the rotor component 14 form a further axial bearing (25).]

[21. A spindle motor according to claim 1, characterized in that a further bearing part (19) connected to the rotor component adjoins the second bearing part (18), a pumping

seal (36) being disposed between the two bearing parts (18, 19) and a sealing gap being disposed between the bearing part (19) and the shaft (12).]

[22. A spindle motor having a fluid dynamic bearing system comprising:

a stationary shaft (12; 212; 312) that is held directly or indirectly in a baseplate (10, 210; 310),

a rotor component (14, 114a; 214; 314a-c) rotatably supported with respect to the shaft about a rotational axis (46; 246; 346),

a bearing gap (20, 220; 320) open at both ends filled with a bearing fluid that separates the adjoining surfaces of the shaft (12; 212; 312), the rotor component (14, 114a; 214; 214a-c) and at least one first bearing part (16, 216; 316) from one another, a first radial bearing (22a, 222a; 322a) and a second radial bearing (22b, 222b; 322b) formed between the opposing axially extending bearing surfaces of the shaft (12; 212; 312) and the rotor component (14, 114a; 214; 314a-c),

an axial bearing (26, 226; 326) formed between the opposing radially extending bearing surfaces of the rotor component (14, 114a; 214; 314a-c) and the first bearing part (16, 216; 316) connected to the baseplate,

a recirculation channel (28; 128; 228; 328) filled with bearing fluid that connects the remote regions of the bearing to each other, and

an electromagnetic drive system (42, 44; 342, 244) for driving the rotor component,

characterized in that the recirculation channel (28, 128; 228) ends in a gap (21) radially outside of the bearing gap (20) of the axial bearing (26), and

further characterized in that the width of the gap (21) is greater than or equal to the width of the bearing gap (20) of the axial bearing (26) plus the depth of the bearing patterns of the axial bearing (26).]

[23. A spindle motor having a fluid dynamic bearing system comprising:

a stationary shaft (12; 212; 312) that is held directly or indirectly in a baseplate (10, 210; 310),

a rotor component (14, 114a; 214; 314a-c) rotatably supported with respect to the shaft about a rotational axis (46; 246; 346),

a bearing gap (20, 220; 320) open at both ends filled with a bearing fluid that separates the adjoining surfaces of the shaft (12; 212; 312), the rotor component (14, 114a; 214; 214a-c) and at least one first bearing part (16, 216; 316) from one another, a first radial bearing (22a, 222a; 322a) and a second radial bearing (22b, 222b; 322b) formed between the opposing axially extending bearing surfaces of the shaft (12; 212; 312) and the rotor component (14, 114a; 214; 314a-c),

an axial bearing (26, 226; 326) formed between the opposing radially extending bearing surfaces of the rotor component (14, 114a; 214; 314a-c) and the first bearing part (16, 216; 316) connected to the baseplate,

a recirculation channel (28; 128; 228; 328) filled with bearing fluid that connects the remote regions of the bearing to each other, and

an electromagnetic drive system (42, 44; 342, 244) for driving the rotor component, and

a sealing gap (32; 332) for sealing the bearing gap (20, 220; 320) which is covered by an annular cover (30, 130; 330) connected to the rotor component (14; 114a; 314c) that, together with the second bearing part (18; 318), forms a labyrinth seal (48; 348).]

[24. A spindle motor according to claim 23, characterized in the annular cover (330) is formed by the rotor component.]

[25. A spindle motor according to claim 23, characterized in that the sealing gap (32) is formed between an inner circumferential surface of the cover (130) and an outer circumferential surface of the second bearing part (18).]

[26. A spindle motor according to claim 23, characterized in that the sealing gap (32; 332) is formed between an inner circumferential surface/end face of the rotor component (14, 114a; 214; 314a; 314c) and an outer circumferential surface/end face of the second bearing part (18; 218; 318).]

[27. A spindle motor according to claim 23, characterized in that the sealing gap (34; 234; 334) is formed between an outer circumferential surface of the rotor component (14, 114a; 214; 314a; 314c) and an inner circumferential surface of the first bearing part (16; 216; 316).]

[28. A spindle motor according to claim 23, characterized in that surfaces of the rotor component (14, 144a; 214) or the cover (130) and the second bearing part (18; 218) forming the sealing gap (32; 232) extend substantially parallel to the rotational axis (46; 246) or are inclined at an acute angle to the rotational axis.]

[29. A spindle motor according to claim 23, characterized in that surfaces of the rotor component (14, 114a; 214; 314a; 314c) and the first bearing part (16; 216; 316) forming the sealing gap (34; 234; 334) extend substantially parallel to the rotational axis (46; 246; 346) or are inclined at an acute angle to the rotational axis.]

[30. A hard disk drive comprising a spindle motor for rotatably driving at least a storage disk, and means for writing on and reading data from the storage disk, the spindle motor having a fluid dynamic bearing system and comprising:

a stationary shaft (12; 212; 312) that is held directly or indirectly in a baseplate (10, 210; 310),

a rotor component (14, 114a; 214; 314a-c) rotatably supported with respect to the shaft about a rotational axis (46; 246; 346),

bearing gap (20, 220; 320) open at both ends filled with a bearing fluid that separates the adjoining surfaces of the shaft (12; 212; 312), the rotor component (14, 114a; 214; 214a-c) and at least one first bearing part (16, 216; 316) from one another, a first radial bearing (22a, 222a; 322a) and a second radial bearing (22b, 222b; 322b) formed between the opposing axially extending bearing surfaces of the shaft (12; 212; 312) and the rotor component (14, 114a; 214; 314a-c),

an axial bearing (26, 226; 326) formed between the opposing radially extending bearing surfaces of the rotor component (14, 114a; 214; 314a-c) and the first bearing part (16, 216; 316) connected to the baseplate, a recirculation channel (28; 128; 228; 328) filled with bearing fluid that connects the remote regions of the bearing to each other, and

an electromagnetic drive system (42, 44; 342, 244) for driving the rotor component,

characterized in that the recirculation channel (28, 128; 228) ends in a gap (21) radially outside of the bearing gap (20) of the axial bearing (26), and

further characterized in that the width of the gap (21) is greater than or equal to the width of the bearing gap (20) of the axial bearing (26) plus the depth of the bearing patterns of the axial bearing (26).]

[31. A spindle motor having a fluid dynamic bearing system comprising:

a stationary shaft (12; 212; 312) that is held directly or indirectly in a baseplate (10, 210; 310),
 a rotor component (14, 114a; 214; 314a-c) rotatably supported with respect to the shaft about a rotational axis (46; 246; 346),
 a bearing gap (20, 220; 320) open at both ends filled with a bearing fluid that separates the adjoining surfaces of the shaft (12; 212; 312), the rotor component (14, 114a; 214; 214a-c) and at least one first bearing part (16, 216; 316) from one another, a first radial bearing (22a, 222a; 322a) and a second radial bearing (22b, 222b; 322b) formed between the opposing axially extending bearing surfaces of the shaft (12; 212; 312) and the rotor component (14, 114a; 214; 314a-c),
 an axial bearing (26, 226; 326) formed between the opposing radially extending bearing surfaces of the rotor component (14, 114a; 214; 314a-c) and the first bearing part (16, 216; 316) connected to the baseplate,
 a recirculation channel (28; 128; 228; 328) filled with bearing fluid that connects the remote regions of the bearing to each other, and
 an electromagnetic drive system (42, 44; 342, 244) for driving the rotor component,
 characterized in that the recirculation channel (28, 128; 228) is disposed in the rotor component (14; 114a; 214) and connects a sealing gap (34) radially outside the axial bearing (26) to a section of the bearing gap (20) adjacent to a dynamic pumping seal (136).]

32. A spindle motor having a fluid dynamic bearing system comprising:

a stationary shaft that is held directly or indirectly in a baseplate;

a rotor component rotatably supported with respect to the shaft about a rotational axis;

a bearing gap open at both ends filled with a bearing fluid, the bearing gap separating adjoining surfaces of the shaft and the rotor component, the bearing gap further separating adjoining surfaces of the rotor component and at least a first bearing part;

a first radial bearing and a second radial bearing formed between the opposing axially extending bearing surfaces of the shaft and the rotor component;

an axial bearing formed between the opposing radially extending bearing surfaces of the rotor component and the first bearing part connected to the baseplate;

a recirculation channel filled with bearing fluid that connects the remote regions of the bearing to each other, the recirculation channel ending in a first gap radially outside of a second gap, the width of the first gap being greater than the width of the second gap, the first gap and the second gap being located at the same side as the axial bearing, a bearing pattern of the axial bearing being formed at least at the second gap, the axial bearing comprising spiral-shaped bearing patterns; and

an electromagnetic drive system for driving the rotor component.

33. A spindle motor according to claim 32, wherein the rotor component comprises an inner, sleeve-shaped rotor component and an outer cup-shaped rotor component.

34. A spindle motor according to claim 33, wherein the inner, sleeve-shaped rotor component is enclosed by a further, sleeve-shaped rotor component on which the outer cup-shaped rotor component is disposed.

35. A spindle motor according to claim 32, wherein the rotor component is a single piece taking the form of a hub/bearing bush arrangement.

36. A spindle motor according to claim 32, wherein the first bearing part is integrally formed with the shaft as one piece.

37. A spindle motor according to claim 32, wherein a second bearing part is integrally formed with the shaft as one piece.

38. A spindle motor according to claim 32, wherein a capillary gap seal is formed between an inner surface of the rotor component and an outer surface of a second bearing part.

39. A spindle motor according to claim 32, wherein a capillary gap seal is formed between an outer surface of the rotor component and an inner surface of the first bearing part.

40. A spindle motor according to claim 32, wherein the recirculation channel is disposed in the rotor component and connects the sealing gap radially outside the axial bearing to a section of the bearing gap located radially outside a dynamic pumping seal.

41. A spindle motor according to claim 32, wherein the recirculation channel is disposed at an incline to the rotational axis, which, on rotation of the rotor component, causes a centrifugal force to be exerted on the bearing fluid held in the recirculation channel, the centrifugal force transporting the bearing fluid through the recirculation channel toward the first bearing part.

42. A spindle motor according to claim 41, wherein the recirculation channel is inclined at an angle of 5 to 15 degrees with respect to the rotational axis.

43. A spindle motor according to claim 41, wherein the centrifugal force exerted on the bearing fluid due to the inclined recirculation channel positively supports a circulation of the bearing fluid, the circulation generated by an overall pumping effect of the axial bearing and the radial bearings.

44. A spindle motor according to claim 43, wherein the pumping force generated by the centrifugal force is directed to the axial bearing.

45. A spindle motor according to claim 43, wherein the centrifugal force is at least twice as big as the force exerted on the bearing fluid due to the overall pumping effect of the axial bearing and the radial bearings.

46. A spindle motor according to claim 32, wherein a dynamic pumping seal is formed between opposing radially extending surfaces of the rotor component and a second bearing part connected to the shaft.

47. A spindle motor according to claim 46, wherein the dynamic pumping seal is formed between a radially extending end face of the rotor component and an adjoining radially extending end face of the second bearing part.

48. A spindle motor according to claim 46, wherein the dynamic pumping seal is disposed substantially perpendicular to the rotational axis and the sealing gap of the gap seal is substantially parallel to the rotational axis.

49. A spindle motor according to claim 32, wherein a ferromagnetic ring is disposed axially opposite a rotor magnet of the electromagnetic drive system, the ferromagnetic ring and rotor magnet generating a magnetic force that is directed in the opposite direction to a bearing force generated by the axial bearing.

50. A spindle motor according to claim 32, wherein the electromagnetic drive system comprises a stator arrangement which is disposed at an axial offset with respect to the rotor magnet and generates a magnetic force that is directed in the opposite direction to a bearing force generated by the axial bearing.

51. A spindle motor according to claim 32, wherein adjacent surfaces of a second bearing part and the rotor component form a further axial bearing.

52. A spindle motor according to claim 32, wherein a third bearing part connected to the rotor component adjoins a second bearing part, a pumping seal being disposed between the second and the third bearing parts and a sealing gap being disposed between the third bearing part and the shaft.

53. A spindle motor according to claim 32, wherein the rotor component comprises an inner part and an outer part, and wherein the recirculation channel is disposed between the inner part and the outer part and connects the sealing gap radially outside the axial bearing to a section of the bearing gap located radially outside a second axial bearing.

54. A spindle motor according to claim 32, wherein a dynamic pumping seal is formed between opposing axially extending surfaces of the rotor component and a second bearing part connected to the shaft.

55. A spindle motor according to claim 32, wherein the bearing pattern of the axial bearing extends over an entire end face of the rotor component or an entire first bearing part from an inside rim to an outer rim.

56. A spindle motor having a fluid dynamic bearing system comprising:

a stationary shaft that is held directly or indirectly in a baseplate;

a rotor component rotatably supported with respect to the shaft about a rotational axis;

a bearing gap open at both ends filled with a bearing fluid, the bearing gap separating adjoining surfaces of the shaft and the rotor component, the bearing gap further separating adjoining surfaces of the rotor component and at least a first bearing part;

a first radial bearing and a second radial bearing formed between the opposing axially extending bearing surfaces of the shaft and the rotor component;

an axial bearing formed between the opposing radially extending bearing surfaces of the rotor component and the first bearing part connected to the baseplate;

a recirculation channel filled with bearing fluid that connects the remote regions of the bearing to each other, the recirculation channel ending in a gap radially outside of the bearing gap of the axial bearing, the gap being at the same axial position as the bearing gap of the axial bearing, the width of the gap being greater than the width of the bearing gap of the axial bearing;

an electromagnetic drive system for driving the rotor component; and

a sealing gap for sealing the bearing gap which is covered by an annular cover connected to the rotor component, the annular cover being connected to an outer circumferential surface of the rotor component or to a recess positioned at an end face of the rotor component.

57. A spindle motor according to claim 56, wherein the sealing gap is formed between an inner circumferential surface of the rotor component and an outer circumferential surface of a second bearing part.

58. A spindle motor according to claim 56, wherein the sealing gap is formed between an outer circumferential surface of the rotor component and an inner circumferential surface of the first bearing part.

59. A spindle motor according to claim 56, wherein the sealing gap extends substantially parallel to the rotational axis or is inclined at an acute angle to the rotational axis.

60. A spindle motor according to claim 56, wherein surfaces of the rotor component and the first bearing part

form another sealing gap, said another sealing gap extending substantially parallel to the rotational axis or being inclined at an acute angle to the rotational axis.

61. A spindle motor according to claim 60, wherein the another sealing gap is formed between an outer circumferential surface of the rotor component and an inner circumferential surface of the first bearing part.

62. A spindle motor according to claim 56, wherein the annular cover is formed by the rotor component.

63. A spindle motor according to claim 56, wherein the sealing gap is formed between an inner circumferential surface of the cover and an outer circumferential surface of a second bearing part.

64. A spindle motor according to claim 56, wherein the annular cover and a second bearing part form a labyrinth seal.

65. A spindle motor according to claim 56, wherein the sealing gap is formed between an end face of the rotor component and an end face of a second bearing part.

66. A spindle motor having a fluid dynamic bearing system comprising:

a stationary shaft that is held directly or indirectly in a baseplate;

a rotor component rotatably supported with respect to the shaft about a rotational axis;

a bearing gap open at both ends filled with a bearing fluid, the bearing gap separating adjoining surfaces of the shaft and the rotor component, the bearing gap further separating adjoining surfaces of the rotor component and at least a first bearing part;

a first radial bearing and a second radial bearing formed between the opposing axially extending bearing surfaces of the shaft and the rotor component;

an axial bearing formed between the opposing radially extending bearing surfaces of the rotor component and the first bearing part connected to the baseplate;

a recirculation channel filled with bearing fluid that connects the remote regions of the bearing to each other, the recirculation channel ending in a first gap radially outside of a second gap, the width of the first gap being greater than or equal to the width of the second gap plus the depth of bearing patterns of the axial bearing, the first gap and the second gap being located at the same side as the axial bearing, a bearing pattern of the axial bearing being formed at least at the second gap, the axial bearing comprising spiral-shaped bearing patterns; and

an electromagnetic drive system for driving the rotor component.

67. A hard disk drive comprising a spindle motor for rotatably driving at least a storage disk, and means for writing on and reading data from the storage disk, the spindle motor having a fluid dynamic bearing system and

comprising:

a stationary shaft that is held directly or indirectly in a baseplate;

a rotor component rotatably supported with respect to the shaft about a rotational axis;

a bearing gap open at both ends filled with a bearing fluid, the bearing gap separating adjoining surfaces of the shaft and the rotor component, the bearing gap further separating adjoining surfaces of the rotor component and at least a first bearing part;

a first radial bearing and a second radial bearing formed between the opposing axially extending bearing surfaces of the shaft and the rotor component;

an axial bearing formed between the opposing radially extending bearing surfaces of the rotor component and the first bearing part connected to the baseplate;

23

an axial bearing formed between the opposing radially
 extending bearing surfaces of the rotor component and
 the first bearing part connected to the baseplate;
 a recirculation channel filled with bearing fluid that
 connects the remote regions of the bearing to each
 other, the recirculation channel ending in a first gap
 radially outside of a second gap, the width of the first
 gap being greater than or equal to the width of the
 second gap plus the depth of the bearing patterns of the
 axial bearing, the first gap and the second gap being
 located at the same side as the axial bearing, a bearing
 pattern of the axial bearing being formed at least at the
 second gap, the axial bearing comprising spiral-
 shaped bearing patterns; and
 an electromagnetic drive system for driving the rotor
 component.
 68. A spindle motor having a fluid dynamic bearing
 system comprising:
 a stationary shaft that is held directly or indirectly in a
 baseplate;
 a rotor component rotatably supported with respect to the
 shaft about a rotational axis;

24

a bearing gap open at both ends filled with a bearing fluid,
 the bearing gap separating adjoining surfaces of the
 shaft and the rotor component, the bearing gap further
 separating adjoining surfaces of the rotor component
 and at least a first bearing part;
 a first radial bearing and a second radial bearing formed
 between the opposing axially extending bearing sur-
 faces of the shaft and the rotor component;
 an axial bearing formed between the opposing radially
 extending bearing surfaces of the rotor component and
 the first bearing part connected to the baseplate;
 a recirculation channel filled with bearing fluid that
 connects the remote regions of the bearing to each
 other, the recirculation channel being disposed in the
 rotor component and connecting a first sealing gap
 radially outside the axial bearing to a section of the
 bearing gap adjacent to a dynamic pumping seal, the
 dynamic pumping seal being positioned between an
 upper end of the recirculation channel and a second
 sealing gap; and
 an electromagnetic drive system for driving the rotor
 component.

* * * * *