

US00RE46283E

(19) **United States**  
(12) **Reissued Patent**  
**de Beaubien**

(10) **Patent Number:** **US RE46,283 E**  
(45) **Date of Reissued Patent:** **Jan. 24, 2017**

(54) **ANTIBIOTIC DELIVERY SYSTEM AND METHOD FOR TREATING AN INFECTED SYNOVIAL JOINT DURING RE-IMPLANTATION OF AN ORTHOPEDIC PROSTHESIS**

(2013.01); *A61F 2002/30672* (2013.01); *A61F 2002/30677* (2013.01); *A61F 2002/368* (2013.01); *A61F 2002/3621* (2013.01); *A61F 2002/3694* (2013.01); *A61F 2002/4685* (2013.01);

(Continued)

(71) Applicant: **Joint Purification Systems LLC**, Solana Beach, CA (US)

(58) **Field of Classification Search**

CPC ..... *A61F 2/4241*  
USPC ..... 632/23.39  
See application file for complete search history.

(72) Inventor: **Brian C. de Beaubien**, Bay City, MI (US)

(73) Assignee: **Joint Purification Systems LLC**, Solana Beach, CA (US)

(56) **References Cited**

U.S. PATENT DOCUMENTS

(21) Appl. No.: **14/817,103**

4,274,163 A \* 6/1981 Malcom et al. .... 606/94  
4,399,814 A \* 8/1983 Pratt et al. .... 606/94

(22) Filed: **Aug. 3, 2015**

(Continued)

**Related U.S. Patent Documents**

Reissue of:

(64) Patent No.: **8,900,322**  
Issued: **Dec. 2, 2014**  
Appl. No.: **13/759,239**  
Filed: **Feb. 5, 2013**

OTHER PUBLICATIONS

Co-pending U.S. Appl. No. 14/841,529, filed Aug. 31, 2015.  
(Continued)

U.S. Applications:

(62) Division of application No. 12/712,748, filed on Feb. 25, 2010, now Pat. No. 8,454,706.

(Continued)

*Primary Examiner* — Beverly M Flanagan

(74) *Attorney, Agent, or Firm* — Wilson, Sonsini, Goodrich & Rosati

(51) **Int. Cl.**

*A61F 2/30* (2006.01)  
*A61F 2/38* (2006.01)  
*A61M 37/00* (2006.01)  
*A61F 2/36* (2006.01)  
*A61F 2/48* (2006.01)

(Continued)

(57) **ABSTRACT**

An antibiotic delivery system including an intramedullary stem that is adapted to be removably mounted into a medullary canal of a bone. The stem includes a body having an inlet adapted to be in fluid communication with a source of liquid-borne antibiotic and a plurality of outlets disposed along the stem. A channel extends between the inlet and the plurality of outlets for delivering a fluid-borne antibiotic from the inlet to the plurality of outlets so as to distribute the antibiotic along the medullary canal in a controlled fashion. A method of treating an infected joint during a two-stage re-implantation of an orthopedic implant is also disclosed.

(52) **U.S. Cl.**

CPC ..... *A61F 2/4241* (2013.01); *A61F 2/36* (2013.01); *A61F 2/38* (2013.01); *A61M 37/00* (2013.01); *A61F 2/4675* (2013.01); *A61F 2002/3068* (2013.01); *A61F 2002/30616*

**22 Claims, 9 Drawing Sheets**

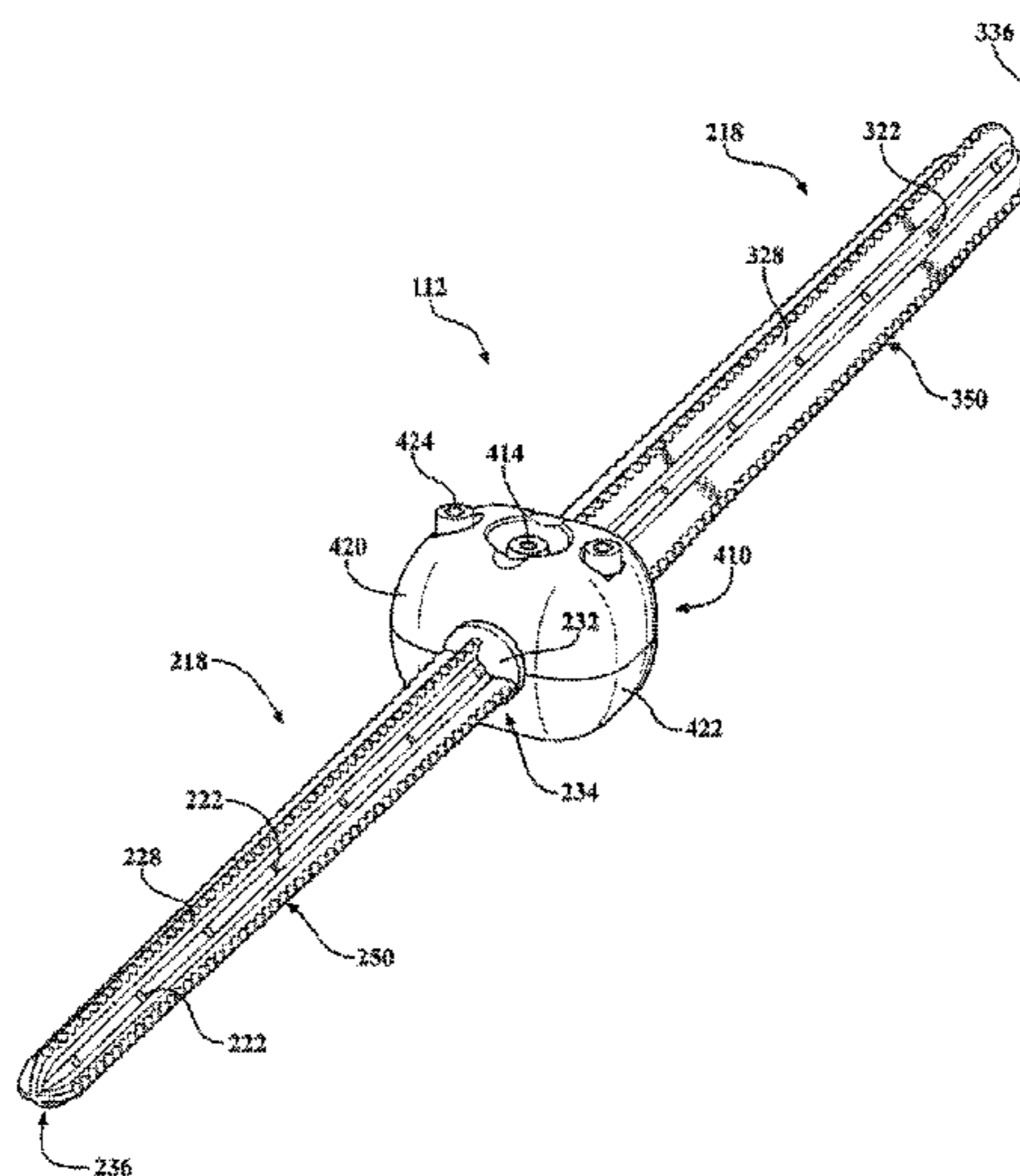

**Related U.S. Application Data**

- (60) Provisional application No. 61/208,540, filed on Feb. 25, 2009.
- (51) **Int. Cl.**  
*A61F 2/46* (2006.01)  
*A61F 2/42* (2006.01)
- (52) **U.S. Cl.**  
 CPC . *A61F 2002/482* (2013.01); *A61F 2250/0068* (2013.01); *A61F 2310/00077* (2013.01)

- 7,048,743 B2 5/2006 Miller et al.  
 7,112,205 B2 9/2006 Carrison  
 7,141,053 B2 11/2006 Rosa et al.  
 7,211,113 B2 5/2007 Zelener et al.  
 7,250,055 B1 \* 7/2007 Vanderwalle ..... 606/92  
 7,255,713 B2 \* 8/2007 Malek ..... 623/17.12  
 7,427,296 B2 \* 9/2008 Evans ..... 623/20.14  
 7,429,346 B2 \* 9/2008 Ensign et al. .... 264/264  
 7,534,240 B1 \* 5/2009 Johnson ..... A61F 13/00063  
 602/43

- 7,572,293 B2 \* 8/2009 Rhodes et al. .... 623/20.32  
 7,601,157 B2 10/2009 Boyd et al.  
 7,601,176 B2 10/2009 Soffiati et al.  
 7,862,619 B2 1/2011 Clark  
 7,914,585 B2 \* 3/2011 Keller ..... 623/23.26  
 8,038,682 B2 10/2011 McGill et al.  
 8,097,039 B2 \* 1/2012 Evans ..... 623/20.14  
 8,135,466 B2 \* 3/2012 Fuller et al. .... 607/22  
 8,388,881 B2 \* 3/2013 Giori ..... 264/250  
 8,454,706 B2 \* 6/2013 de Beaubien ..... 623/23.39  
 8,652,216 B2 \* 2/2014 Chen et al. .... 623/23.72  
 8,673,018 B2 \* 3/2014 Walls ..... 623/23.57  
 8,685,432 B2 \* 4/2014 Evans et al. .... 424/426  
 8,721,520 B2 \* 5/2014 Caira et al. .... 600/30  
 8,900,322 B2 12/2014 de Beaubien  
 8,900,323 B2 12/2014 de Beaubien  
 2003/0060891 A1 \* 3/2003 Shah ..... 623/22.13  
 2003/0097184 A1 5/2003 Mitsugi et al.  
 2003/0187513 A1 \* 10/2003 Durniak ..... 623/22.12  
 2004/0036189 A1 \* 2/2004 Ensign et al. .... 264/40.1  
 2004/0193281 A1 \* 9/2004 Grimes ..... 623/22.12  
 2004/0225360 A1 \* 11/2004 Malone ..... 623/17.11  
 2005/0021084 A1 \* 1/2005 Lu et al. .... 606/218  
 2005/0187555 A1 \* 8/2005 Biedermann et al. .... 606/72  
 2006/0014120 A1 \* 1/2006 Sopian ..... 433/173  
 2006/0093646 A1 \* 5/2006 Cima et al. .... 424/425  
 2006/0121083 A1 \* 6/2006 Mor ..... 424/426  
 2007/0005142 A1 1/2007 Rhodes et al.  
 2007/0110804 A1 \* 5/2007 Royer ..... 424/468  
 2009/0069899 A1 \* 3/2009 Klein ..... 623/22.4  
 2010/0042167 A1 \* 2/2010 Nebosky et al. .... 606/315  
 2010/0042213 A1 \* 2/2010 Nebosky et al. .... 623/16.11  
 2010/0042214 A1 \* 2/2010 Nebosky et al. .... 623/16.11  
 2010/0042215 A1 \* 2/2010 Stalcup et al. .... 623/16.11  
 2010/0217401 A1 \* 8/2010 de Beaubien ..... 623/20.34  
 2010/0292803 A1 \* 11/2010 Giori ..... 623/20.14  
 2011/0236501 A1 \* 9/2011 Guelcher et al. .... 424/549  
 2013/0041472 A1 \* 2/2013 Rabiner et al. .... 623/18.11  
 2013/0209522 A1 \* 8/2013 Brooks et al. .... 424/400  
 2013/0211334 A1 \* 8/2013 de Beaubien ..... 604/175  
 2013/0211369 A1 \* 8/2013 de Beaubien ..... 604/500

(56) **References Cited**

U.S. PATENT DOCUMENTS

- 4,488,549 A \* 12/1984 Lee et al. .... 606/94  
 4,711,233 A \* 12/1987 Brown ..... 606/81  
 4,888,024 A \* 12/1989 Powlan ..... 623/23.19  
 4,892,550 A \* 1/1990 Huebsch ..... 623/23.19  
 5,116,377 A \* 5/1992 Skripitz et al. .... 623/23.19  
 5,133,767 A \* 7/1992 Frey et al. .... 623/23.54  
 5,133,771 A \* 7/1992 Duncan et al. .... 623/23.2  
 5,133,772 A \* 7/1992 Hack et al. .... 623/23.19  
 5,156,606 A 10/1992 Chin  
 5,290,291 A 3/1994 Linden  
 5,340,362 A \* 8/1994 Carbone ..... 623/23.19  
 5,376,123 A \* 12/1994 Klaue et al. .... 623/23.19  
 5,433,718 A \* 7/1995 Brinker ..... 606/62  
 5,501,687 A \* 3/1996 Willert et al. .... 606/94  
 5,514,137 A \* 5/1996 Coutts ..... 606/62  
 5,554,111 A \* 9/1996 Morrey et al. .... 604/26  
 5,562,736 A \* 10/1996 Ray et al. .... 606/86 A  
 5,571,204 A 11/1996 Nies  
 5,681,289 A \* 10/1997 Wilcox ..... A61B 17/60  
 604/175  
 5,702,446 A 12/1997 Schenck et al.  
 5,725,596 A 3/1998 Burke  
 5,741,265 A 4/1998 Chan  
 5,755,811 A 5/1998 Tanamal et al.  
 5,827,289 A 10/1998 Reiley et al.  
 5,954,771 A 9/1999 Richelsoph et al.  
 5,980,573 A \* 11/1999 Shaffner ..... 128/898  
 6,066,154 A 5/2000 Reiley et al.  
 6,113,639 A \* 9/2000 Ray et al. .... 623/17.16  
 6,155,812 A \* 12/2000 Smith et al. .... 425/318  
 6,217,619 B1 4/2001 Keller  
 6,235,043 B1 5/2001 Reiley et al.  
 6,248,110 B1 6/2001 Reiley et al.  
 6,361,731 B1 \* 3/2002 Smith et al. .... 264/271.1  
 6,361,780 B1 \* 3/2002 Ley et al. .... 424/400  
 6,423,083 B2 7/2002 Reiley et al.  
 6,447,514 B1 9/2002 Stalcup et al.  
 6,544,472 B1 \* 4/2003 Compton et al. .... 419/2  
 6,589,281 B2 7/2003 Hyde, Jr.  
 6,679,890 B2 1/2004 Margulies et al.  
 6,740,090 B1 \* 5/2004 Cragg et al. .... 606/79  
 6,740,120 B1 \* 5/2004 Grimes ..... 623/22.12  
 6,783,515 B1 8/2004 Miller et al.  
 6,921,403 B2 \* 7/2005 Cragg et al. .... 606/86 R  
 6,942,702 B2 9/2005 Mitsugi et al.  
 6,969,404 B2 \* 11/2005 Ferree ..... 623/17.11  
 6,979,336 B2 \* 12/2005 Durniak ..... 606/92  
 6,981,981 B2 1/2006 Reiley et al.  
 6,989,033 B1 \* 1/2006 Schmidt ..... 623/23.51

OTHER PUBLICATIONS

- Notice of allowance dated Feb. 22, 2013 for U.S. Appl. No. 12/712,748.  
 Notice of allowance dated Aug. 27, 2014 for U.S. Appl. No. 13/759,239.  
 Notice of allowance dated Aug. 27, 2014 for U.S. Appl. No. 13/759,253.  
 Office action dated Feb. 22, 2012 for U.S. Appl. No. 12/712,748.  
 Office action dated Mar. 21, 2014 for U.S. Appl. No. 13/759,253.  
 Office action dated Mar. 24, 2014 for U.S. Appl. No. 13/759,239.  
 Office action dated Sep. 10, 2012 for U.S. Appl. No. 12/712,748.

\* cited by examiner

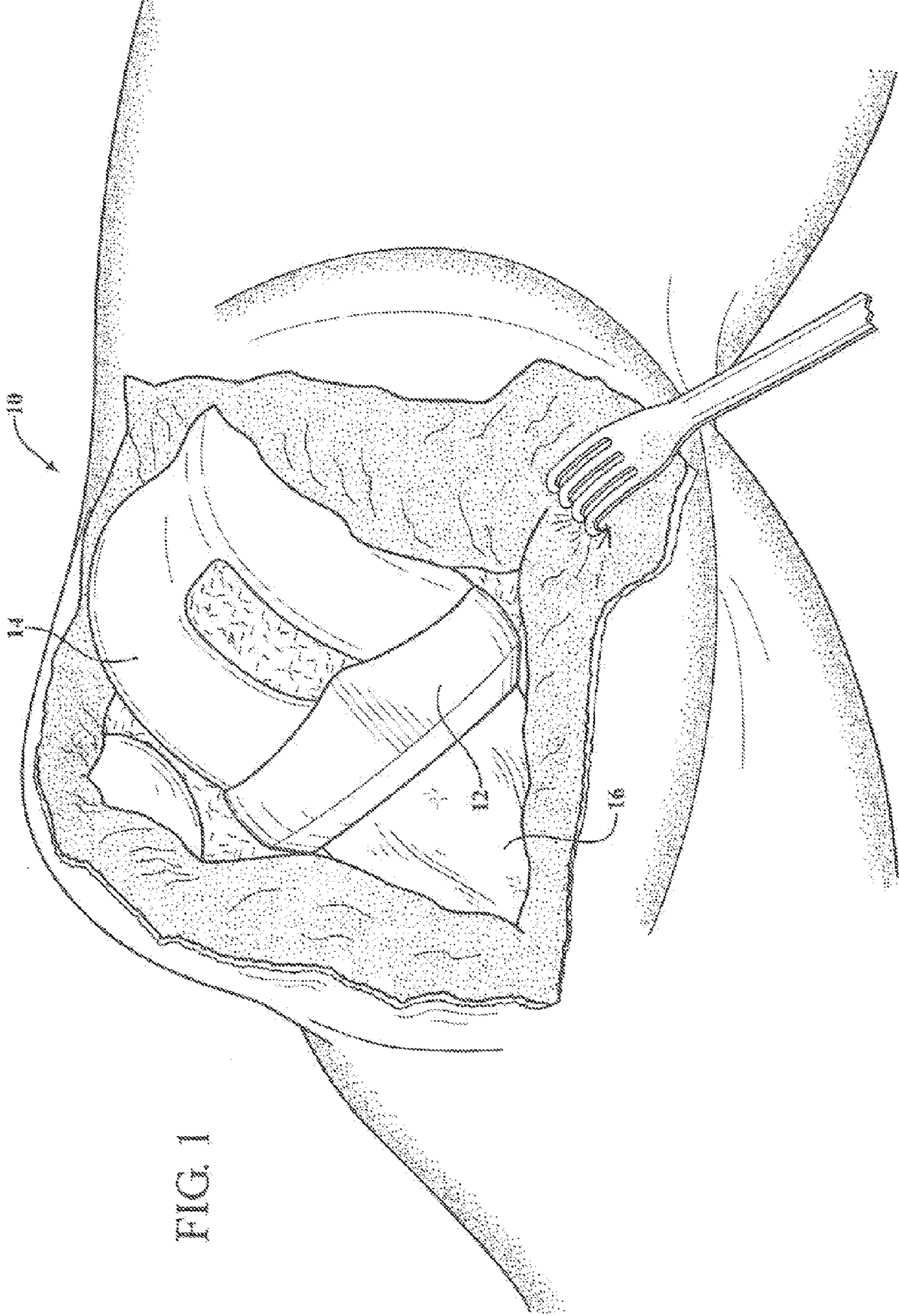
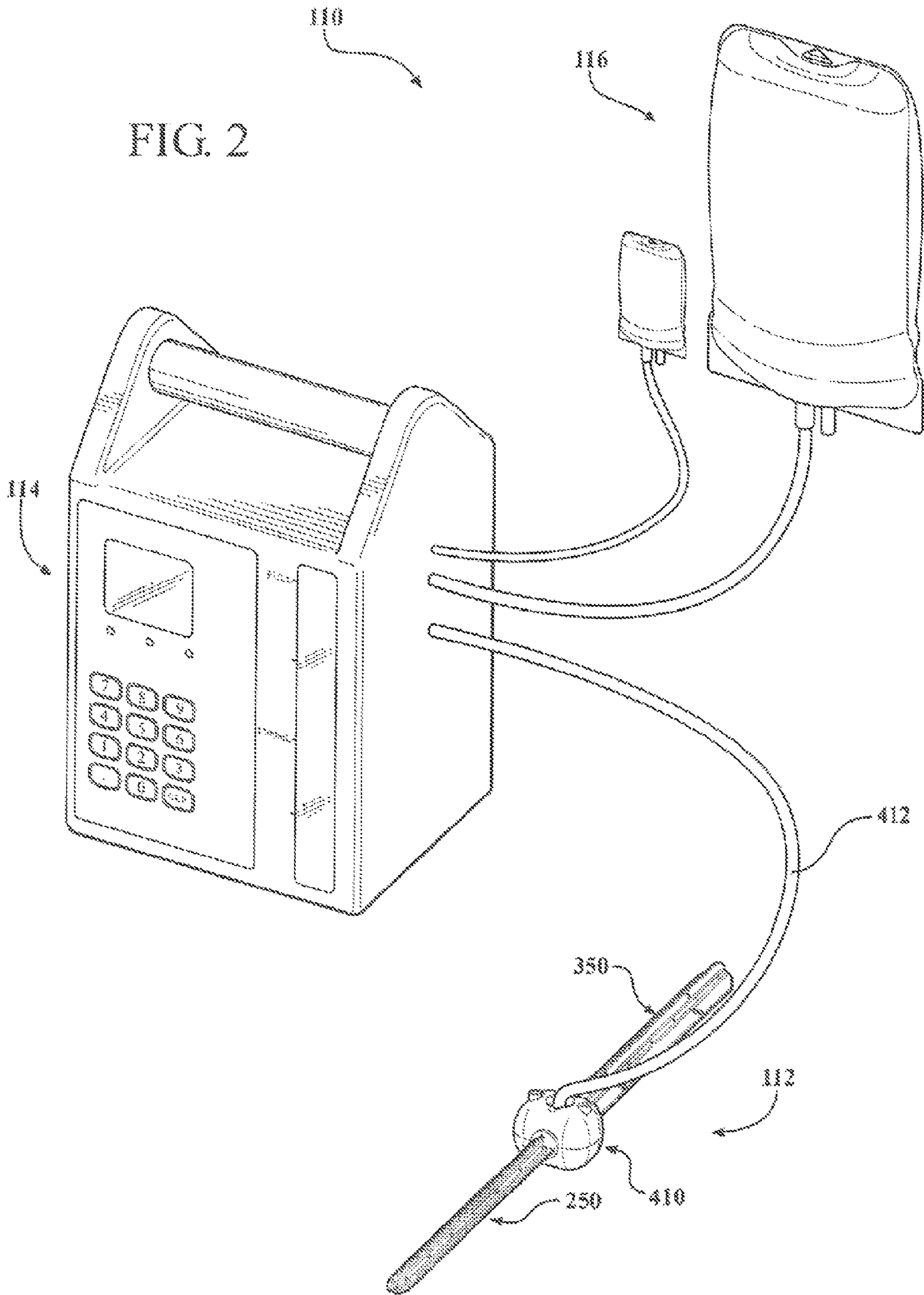
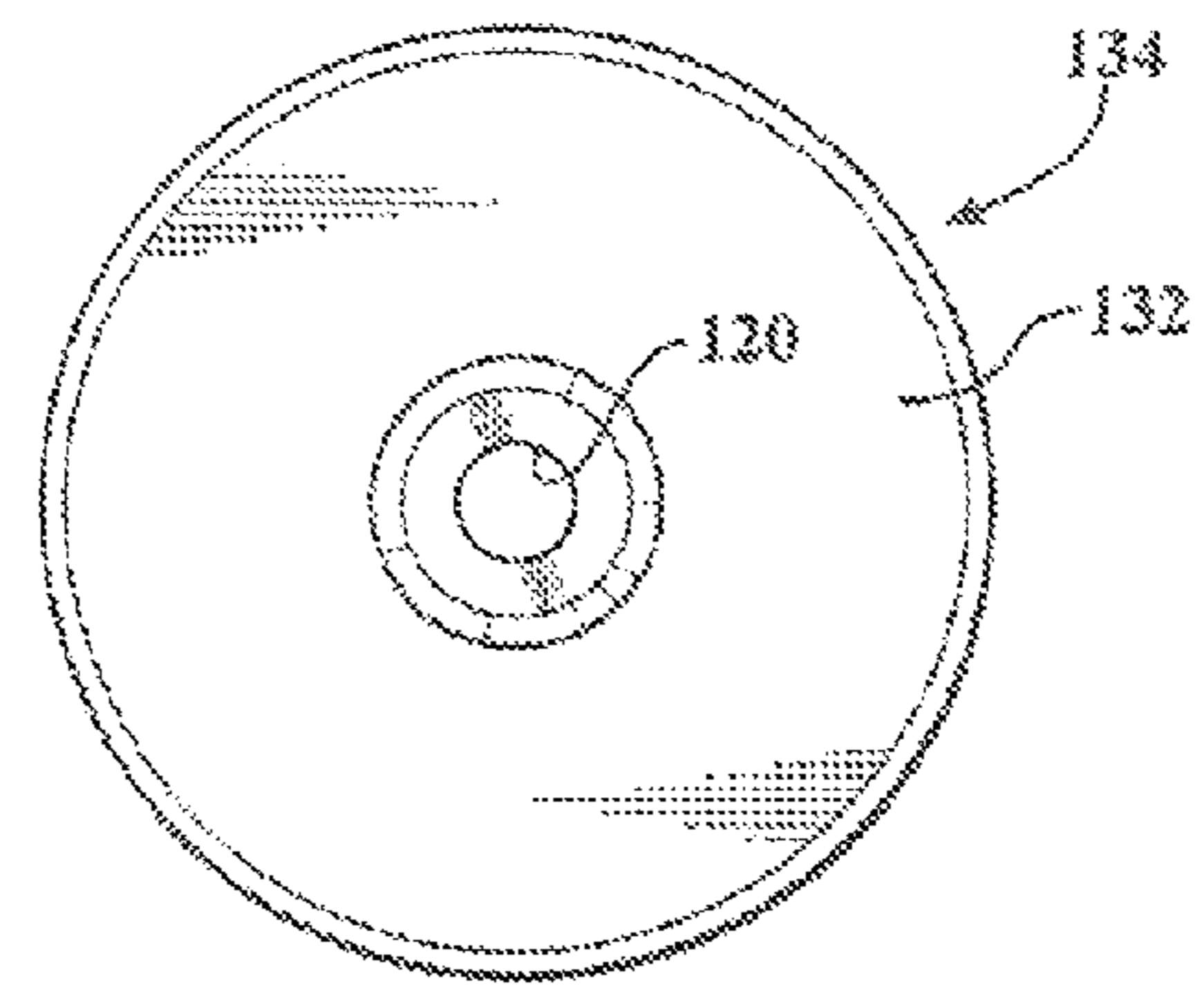
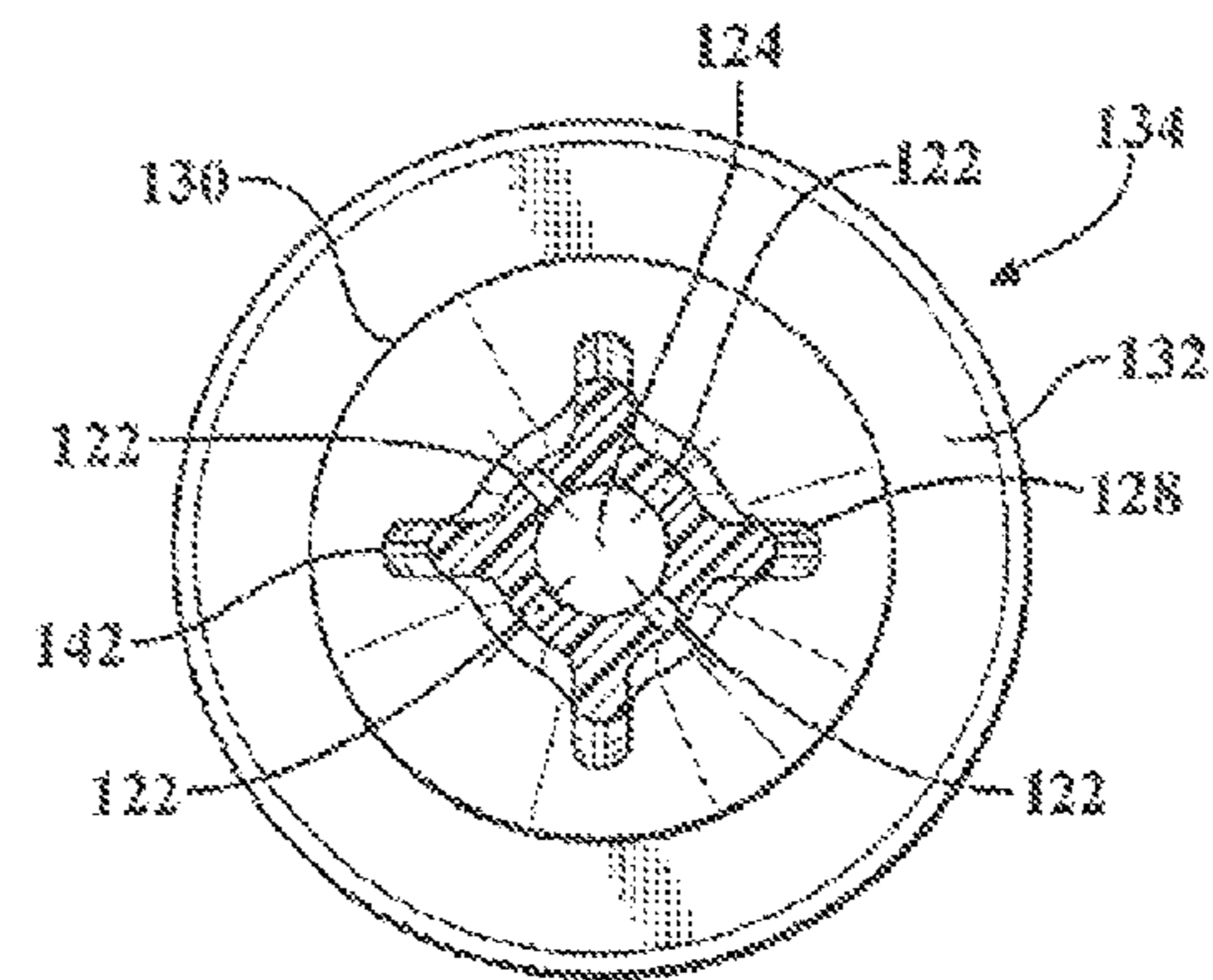
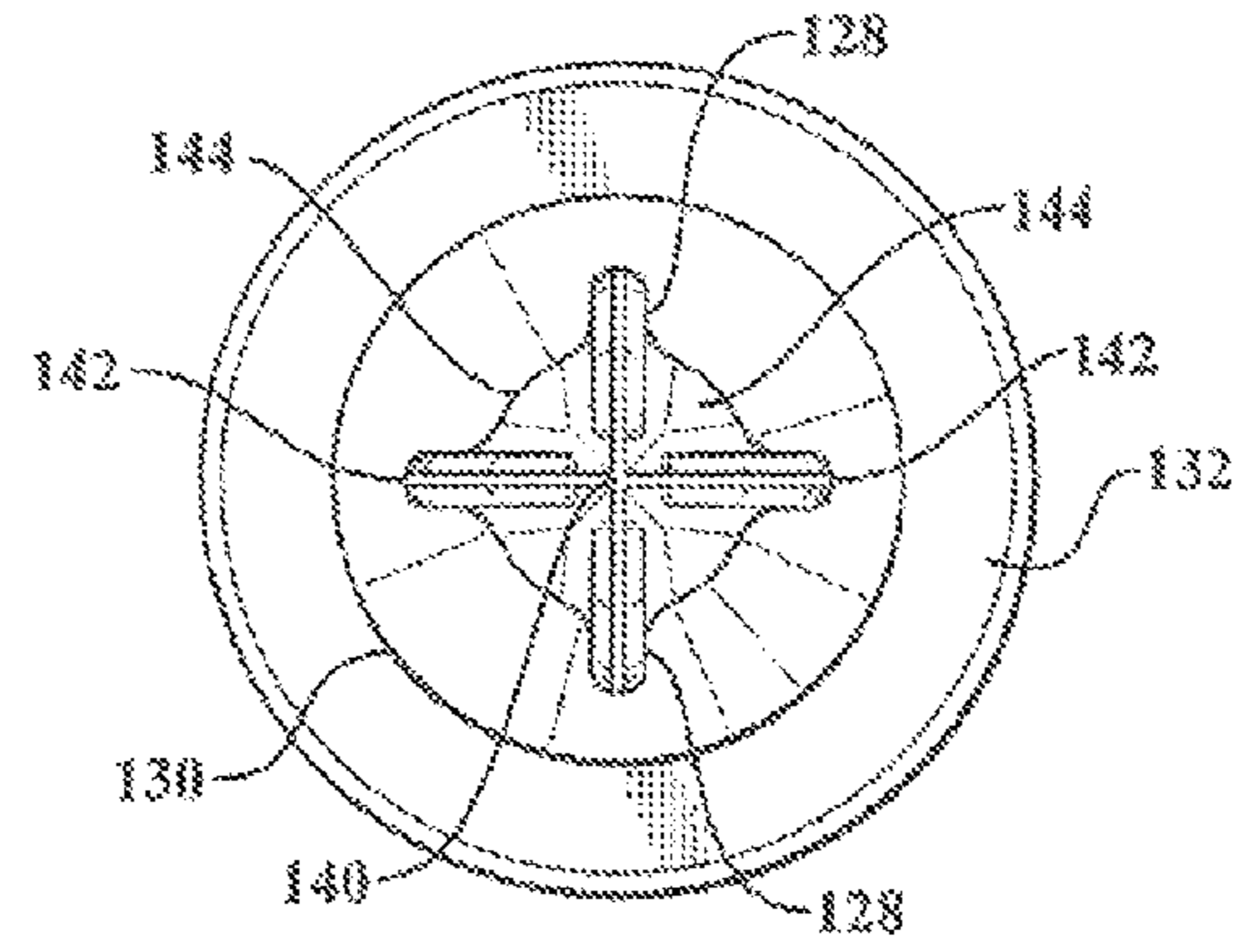
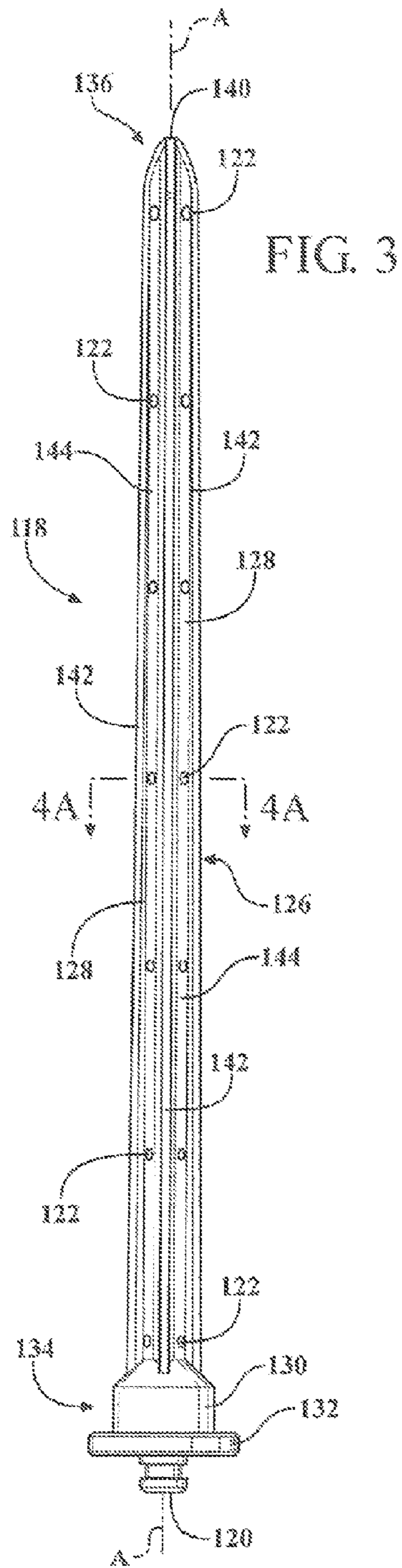
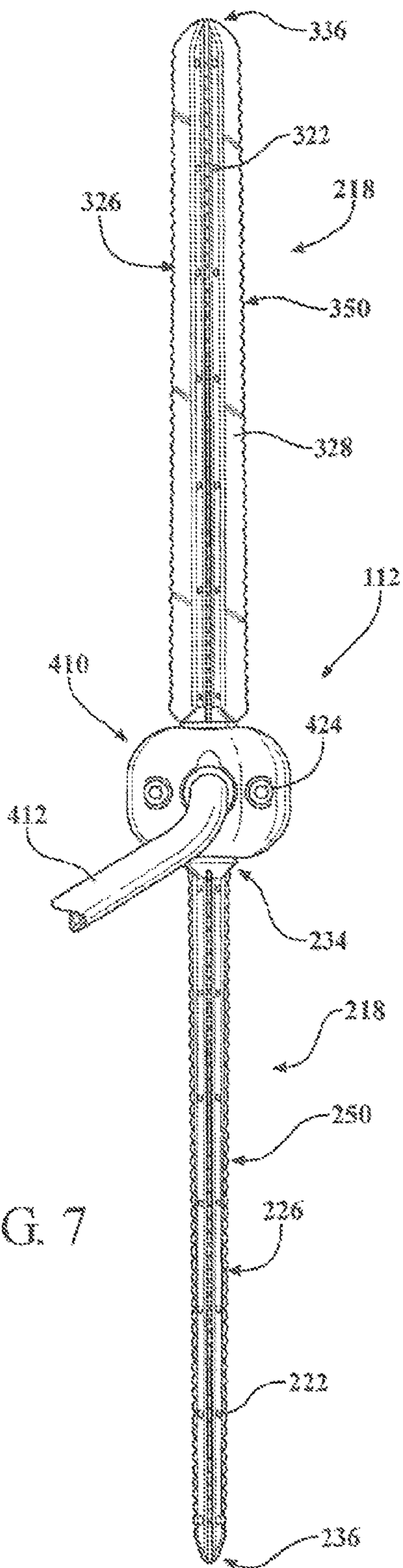
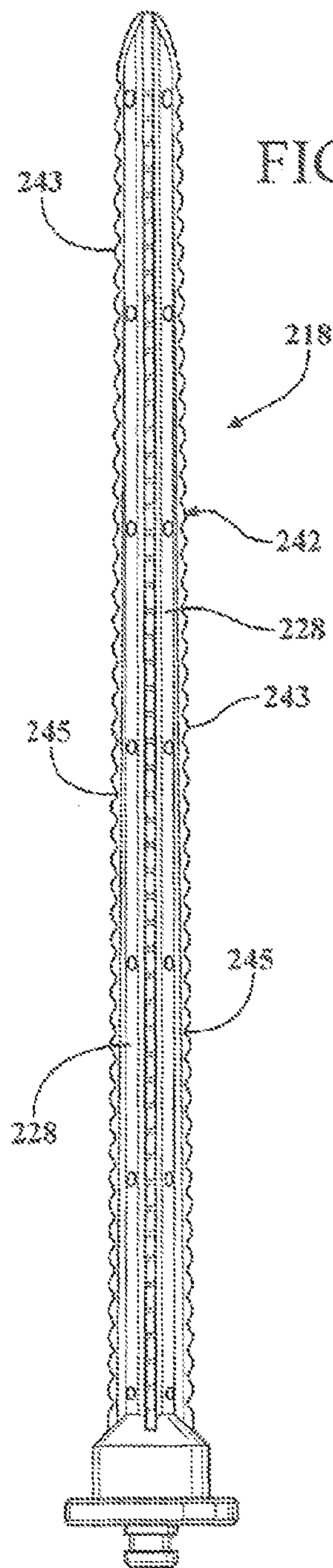
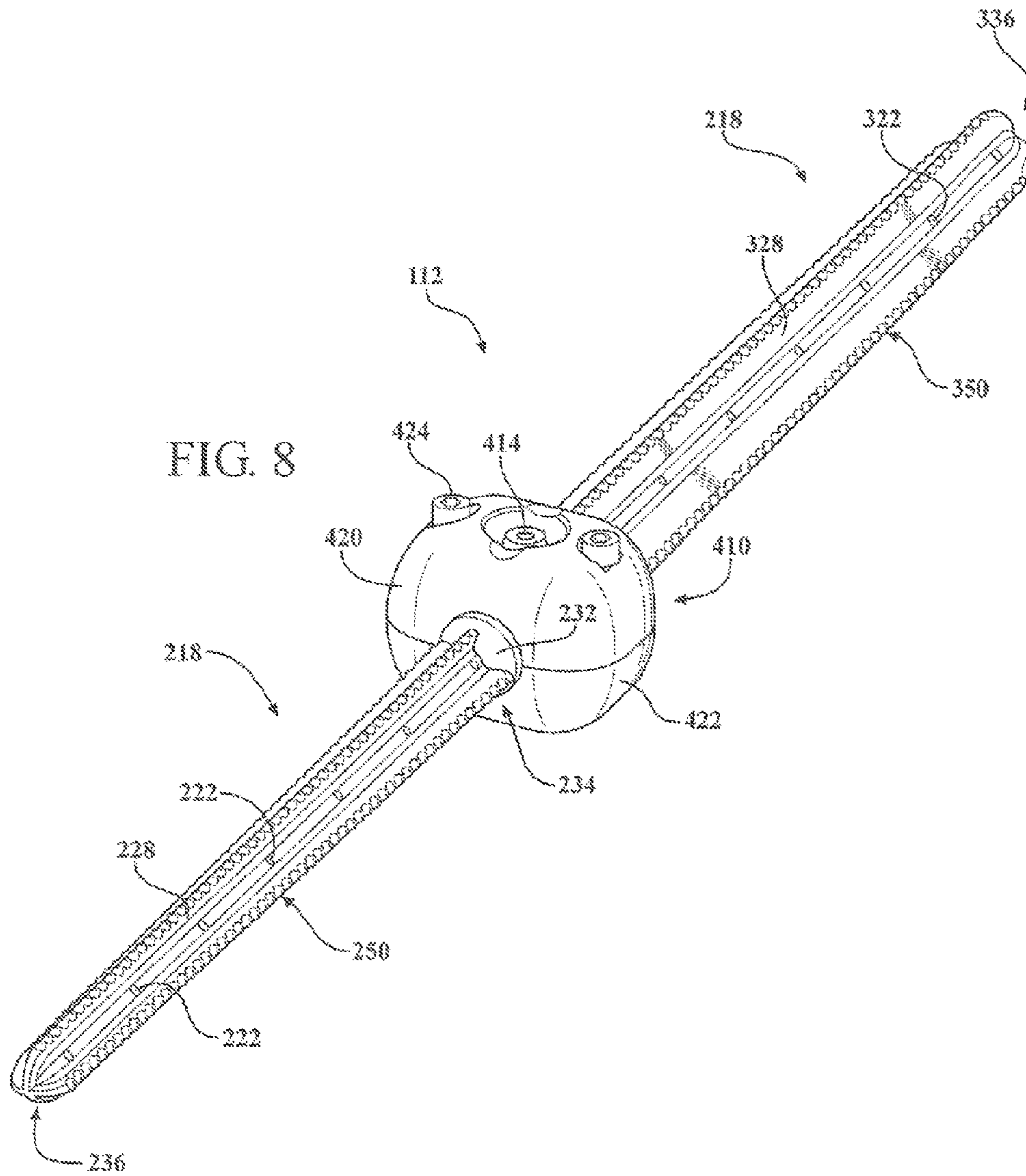

FIG. 1









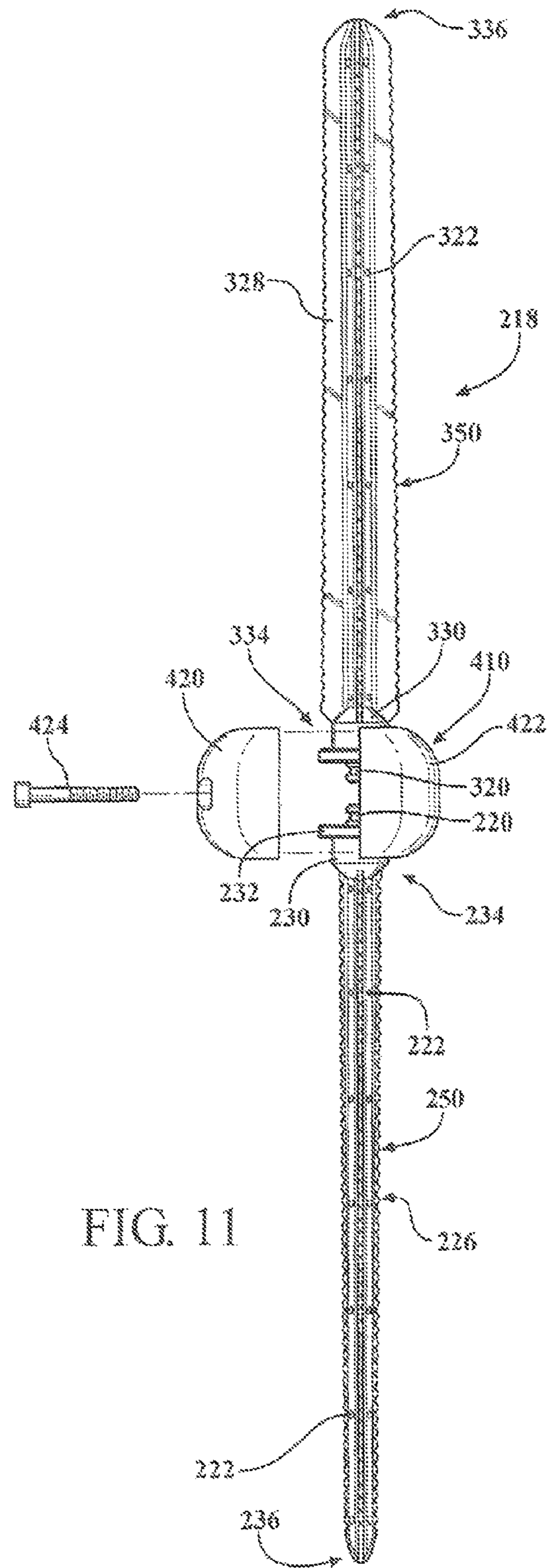
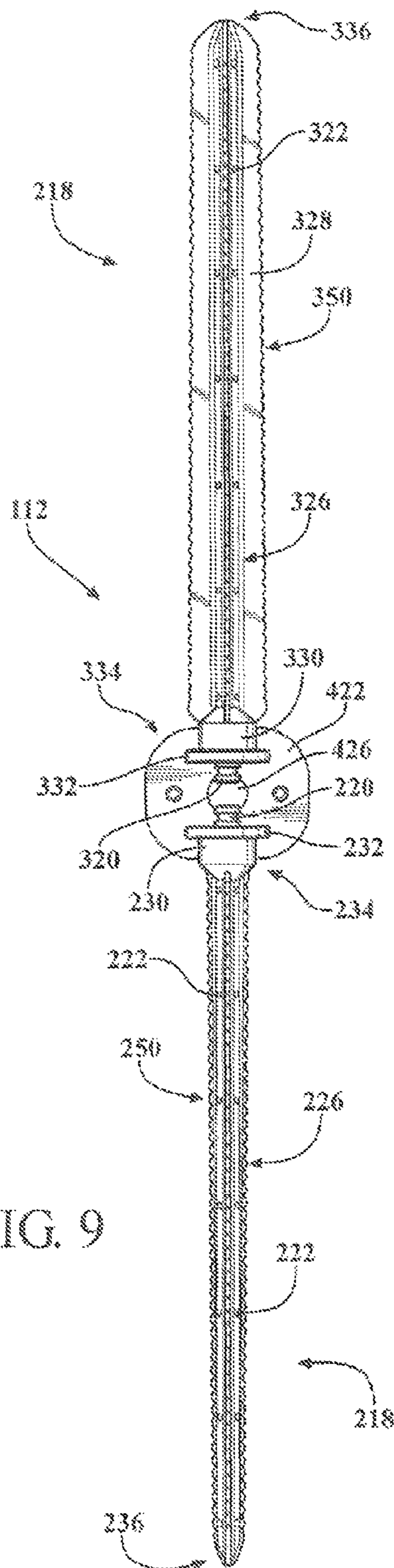



FIG. 10

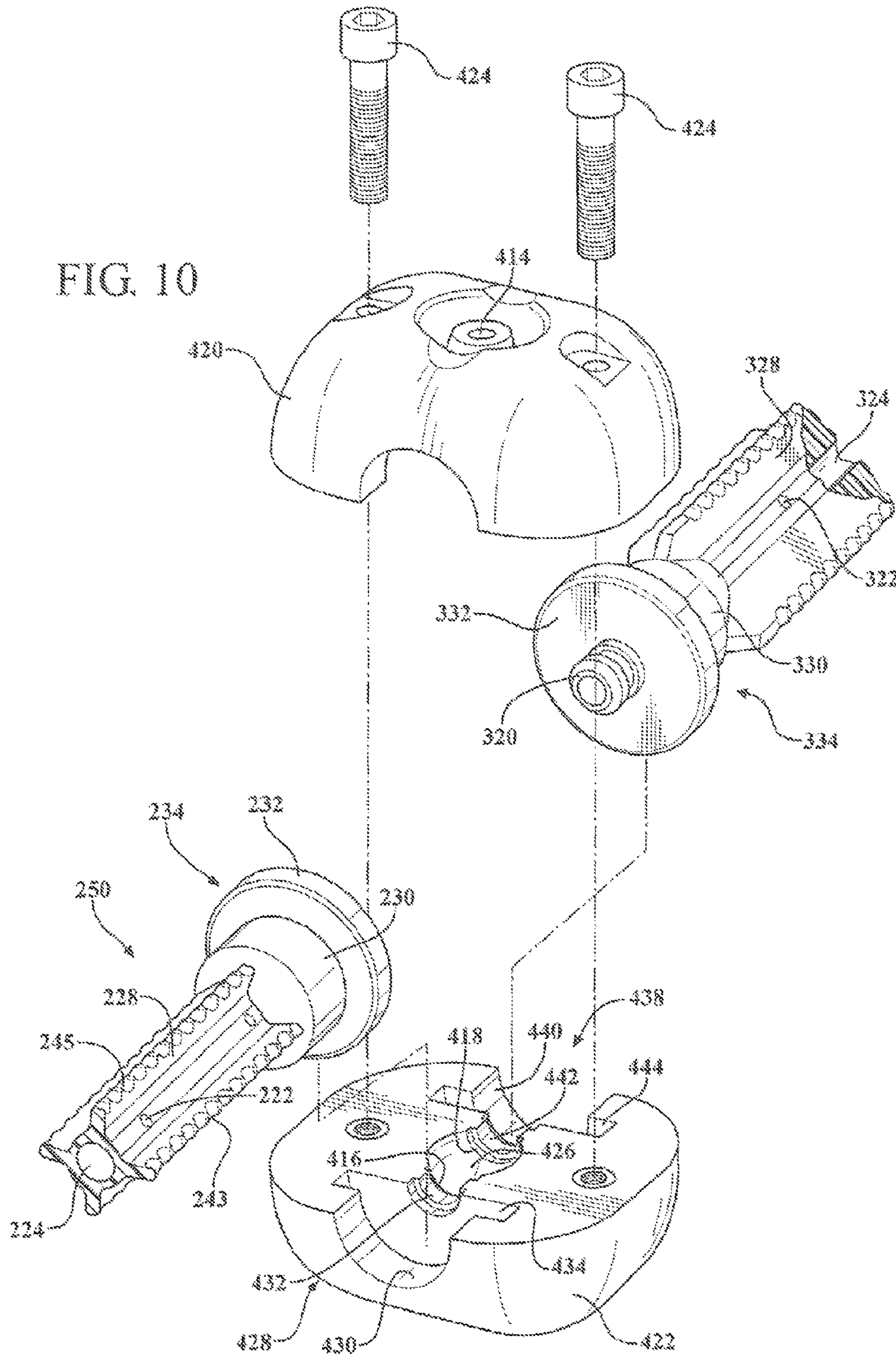
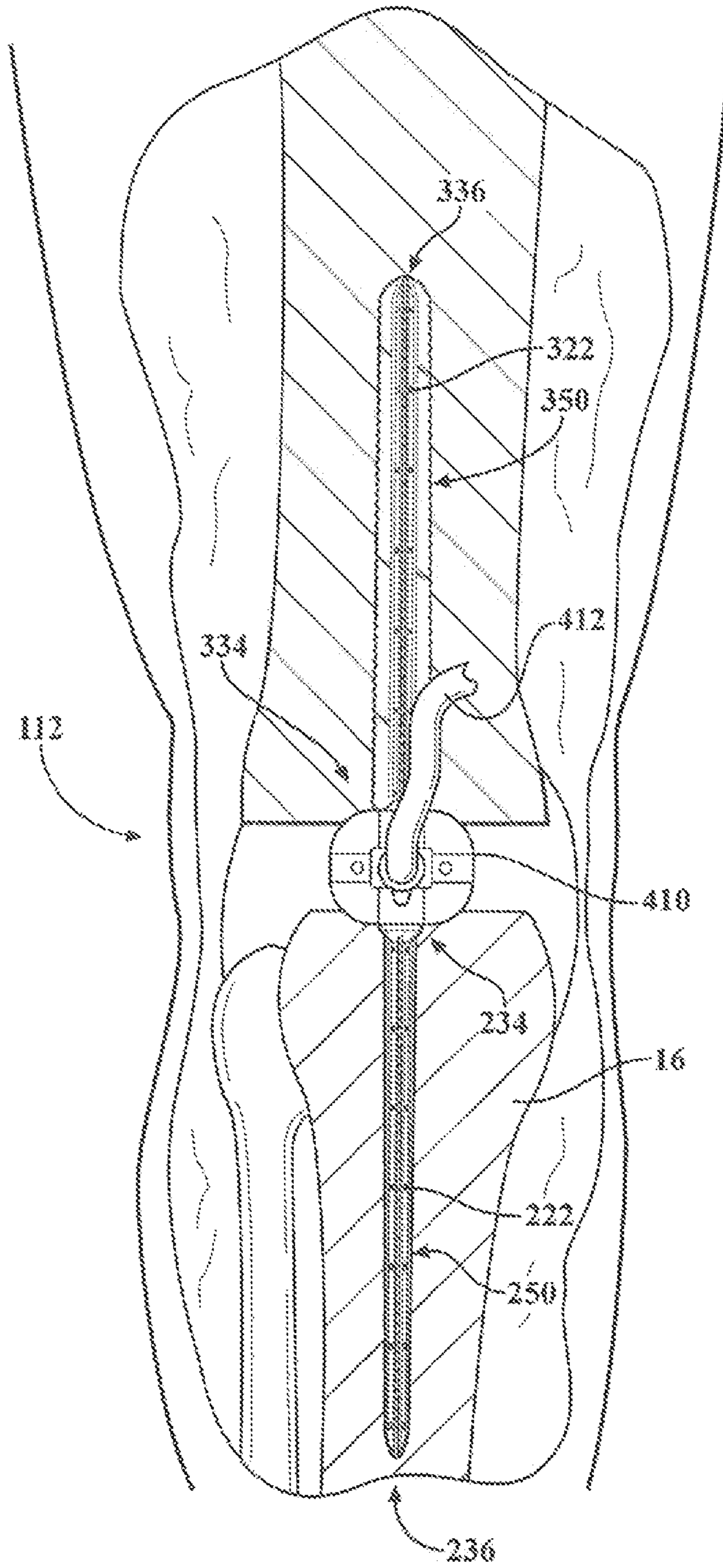
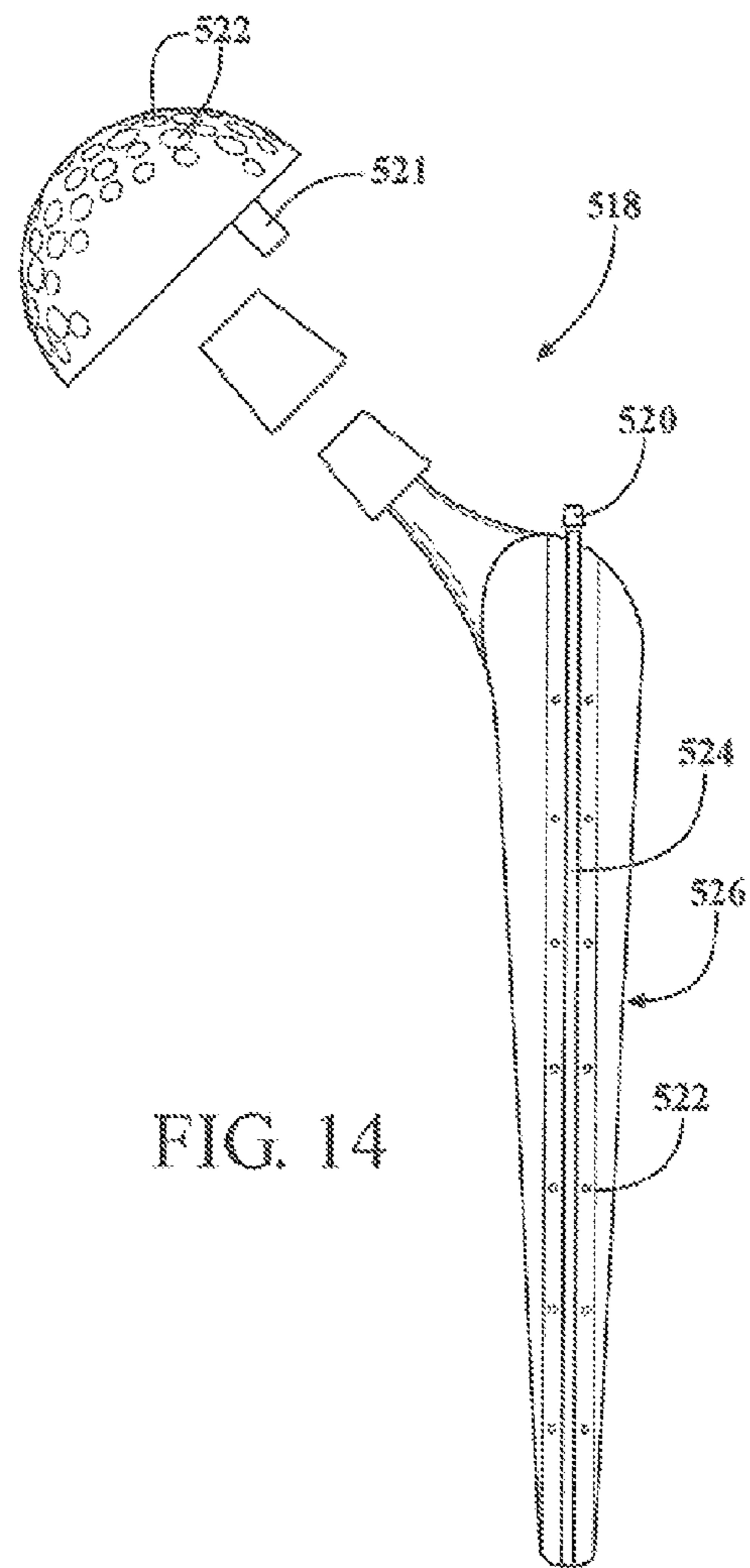
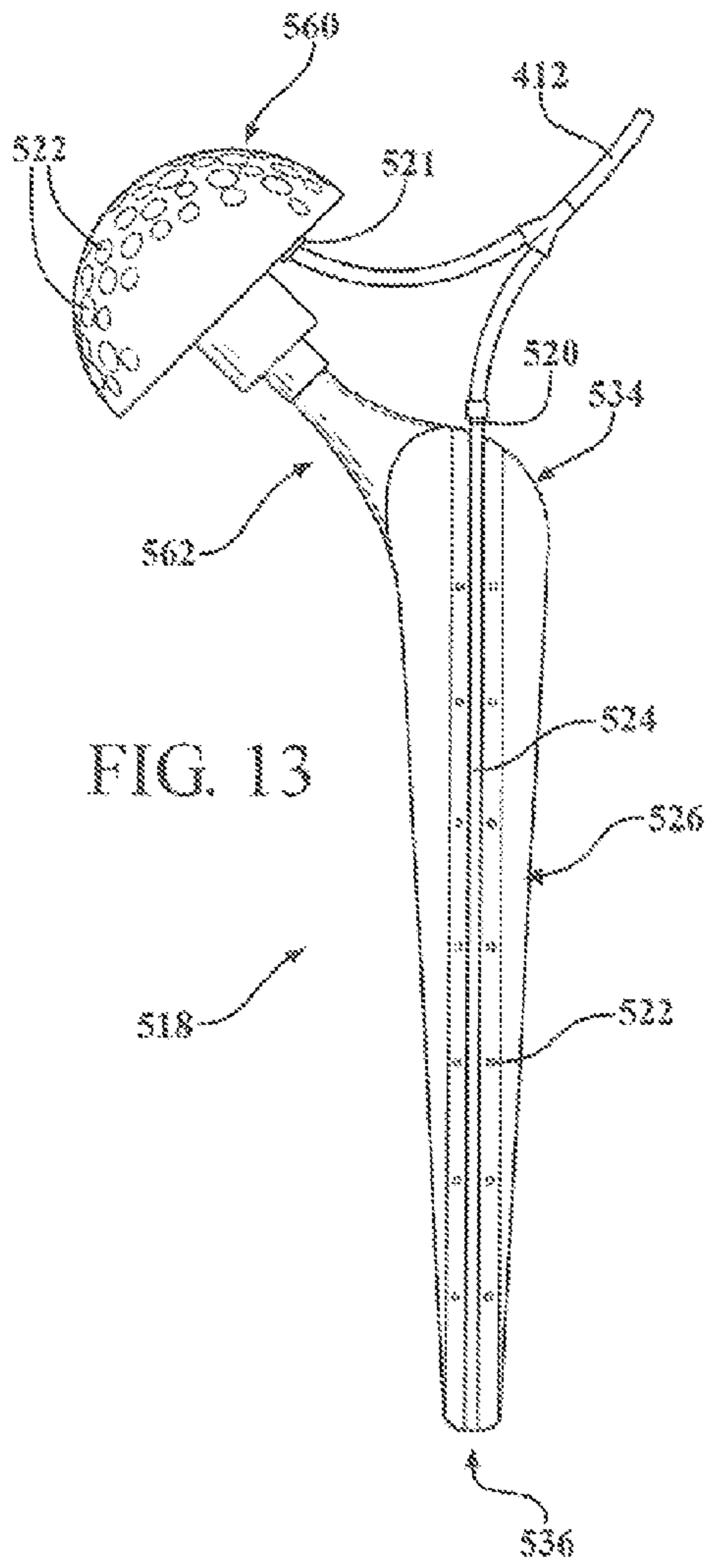

FIG. 12





**ANTIBIOTIC DELIVERY SYSTEM AND  
METHOD FOR TREATING AN INFECTED  
SYNOVIAL JOINT DURING  
RE-IMPLANTATION OF AN ORTHOPEDIC  
PROSTHESIS**

**Matter enclosed in heavy brackets [ ] appears in the original patent but forms no part of this reissue specification; matter printed in italics indicates the additions made by reissue; a claim printed with strikethrough indicates that the claim was canceled, disclaimed, or held invalid by a prior post-patent action or proceeding.**

CROSS-REFERENCE TO RELATED  
APPLICATION(S)

This application is a divisional of U.S. patent application entitled "Antibiotic Delivery System and Method for Treating an Infected Synovial Joint During Re-implantation of an Orthopedic Prosthesis," having U.S. Ser. No. 12/712,748, and filed Feb. 25, 2010, which claims the benefit of U.S. provisional patent application entitled "Joint Purification Systems," having Ser. No. 61/208,540, and filed on Feb. 25, 2009.

BACKGROUND OF THE INVENTION

1. Field of the Invention

The present invention relates, generally, to an antibiotic delivery system and, more specifically, to such a system and method for treating an infected synovial joint and adjacent medullary canals as a means of eliminating infection during a two-stage re-implantation of an orthopedic prosthesis.

2. Description of the Related Art

A total joint replacement (TJR) is a medical procedure that involves the repair and replacement of joints, such as hips and knees. In these cases, the bones at the hip or knee joints are prepared to receive orthopedic implants that mimic the structure of the joint that is replaced. For example, a total knee replacement is representatively shown at **10** in FIG. 1. The total knee replacement **10** includes tibial **12** and femoral **14** components that imitate the structure and function of the natural knee joint. The tibial component **12** is operatively mounted to the tibia bone **16** and the femoral component **14** is operatively mounted to the femoral bone (not shown). Similarly, a total hip replacement includes a femoral component that terminates in a neck having a hemispherical ball that mimics the upper terminal portion of the natural femoral bone.

Currently, there are approximately one million total joint replacement (TJR) surgeries involving either hips or knees performed annually in the United States. Obviously, more TJR surgeries are performed throughout the world. However, the demand for TJR surgery is expected to soar in the future. Doctor-diagnosed arthritis is expected to increase 40% from 2005 to 2030. According to the 2003 National Institute of Health Census Panel Report on total knee replacement, only 9% to 13% of TJR candidates have been willing to undergo the procedure. As patients become more aware of their options, as well as the success of TJR, demand may reach even higher levels.

Baby boomers will start reaching the age of 65 years in 2011. Also, over the past decade, the prevalence of TJR has increased not only in older patients (those who are 65 years or older) but also in younger patients (those less than 65 years old). Premium implant technology such as hard-on-

hard bearings and hip resurfacing have been introduced to address the increased activity and longevity of younger patients. The demand for primary total hip and total knee replacements on patients younger than 65 years old was projected to exceed 50% of joint replacement recipients by 2011 and 2013, respectively. Demand for primary total hip replacement is expected to grow 174% and for total knee replacement by 673% by the year 2030. Data collected from the U.S. Nationwide Implant Sample (NIS) between 1993 and 2005 has also been evaluated. This data indicates that by 2030 future demand of primary and revision TJR procedures (where an older implant is replaced with a new one) will be significant. For example, primary total knee replacements are projected to be 4,580,000. The need to revise and re-implant total knee replacements is projected to be 269,000. Primary total hip replacements are projected to be 975,000. And the need to revise and re-implant total hip replacements is projected to be 103,000 per year. These estimated projections total 6,000,000 TJR surgeries annually.

In relatively rare cases, however, infection is a devastating complication of TJR surgeries. The rate of infection in these types of surgeries ranges between 0.5% and 1.5%. Unless an infection is properly diagnosed within the first two to four weeks following the original surgery (which is uncommon), the infected implant must be removed in combination with an extensive debridement of the surrounding joint tissue and bone. According to the Center for Disease Control, there are currently approximately 12,000 infected TJR cases annually in the United States. Obviously, this number increases when the entire worldwide scope of TJR surgeries is considered. At 1% infection rate, and assuming the projections noted above are generally accurate, there will be 60,000 instances of infected total joints annually in the future.

Over the past two decades, the standard of care for treatment of an infected TJR in the United States has included a two-stage re-implantation process. In the first stage of this process, the infected components are surgically exposed by incision. Scar tissue is then de-bulked as well as other soft tissue releases, and sometimes an osteotomy. This stage also includes the removal of all prosthetic components and foreign material including, for example, acrylic bone cement. After extensive joint debridement of infected soft tissue and bone, a spacer block consisting of heavily dosed antibiotic bone cement is placed temporarily into the joint space. The purpose of the antibiotic bone cement is to sterilize the joint environment and to serve as an antibiotic delivery system. Additionally, the bone cement acts as a spacer to preserve joint space and maintains ligament length. However, the antibiotic released by the bone cement is uncontrolled and is quite costly to use. For example, a typical knee spacer may require three bags of acrylic bone cement, twelve vials of an antibiotic such as Tobramycin (1.2 g) at a cost of \$800 per vial, and six vials of an antibiotic such as Vancomycin (1 g) at \$17 per vial. This quickly adds up to about \$11,000 in material alone. In addition, more operating room time is necessary to prepare this spacer material. This increases the cost of the operation.

Under the current standard of care, following the removal of the infected implant and the insertion of the antibiotic bone cement spacer, the patient must generally wait between six and, more typically, twelve weeks before the second stage of the procedure can be performed. This period of time is necessary so that the medical professionals can be confident that the infection has been successfully eradicated. Only after the infectious condition has been eliminated, may the second stage proceed. During the second stage, the new

prosthesis is re-implanted. The success rate with this two-stage re-implantation process is typically around 90%.

In other countries, such as throughout Europe, a one-stage re-implantation process has been popular. This involves the removal of the infected implant, as noted above, followed by aggressive debridement and then immediate re-implantation of a new implant. The success rate for this technique has typically been in the 70%-85% range. However, this technique has not gained popularity to any degree in the United States. The one-stage implantation process is generally reserved for patients who are considered to be too feeble or sick to undergo the traditional two-stage re-implantation process.

Both the one-stage and two-stage surgical re-implantation protocols have their disadvantages. For example, and as noted above, the two-stage re-implantation process requires six to twelve weeks between operations. This is a very difficult time for the patient as they do not have a functional joint in place and it is typically very painful to mobilize or ambulate with an antibiotic spacer. Articulating spacers are somewhat better than static spacers, but are also more expensive as well as more difficult and time-consuming to place during the original stage one procedure. From a health care standpoint, the two-stage procedure also requires two separate hospitalizations. Finally, from a surgeon's standpoint, a significant amount of scar tissue develops during the time span between the two procedures. This makes for a very difficult and time-consuming second stage operation. In addition, the two-stage re-implantation process involves not one, but two, very difficult surgical procedures. The estimated cost of removing the infected original implant, eliminating the infection, extended hospitalization, nursing home care or home health care during the period between the first and second operations, as well as re-implanting a new prosthesis is currently roughly \$100,000 per case. This is a tremendous overall burden on the universal health care system and, in the United States alone, reaches approximately \$1.2 billion per year. This statistic does not begin to measure losses in patient economic productivity, quality of life, as well as pain and suffering. Moreover, this statistic does not reflect the costs associated with the projected increase in TJR operations in the future as noted above.

On the other hand, a one-stage re-implantation surgical protocol requires absolute identification of the infecting organism in order to proceed. Unfortunately, it is very difficult to achieve this absolute identification in the current health care systems. In addition, a one-stage re-implantation protocol requires the use of fully-cemented components. Fully-cemented components are typically not favored by U.S. surgeons for revision surgery. Fully-cemented components typically require very high amount of antibiotic. This often is as high as 10% by weight. For example, 4 g of antibiotic are required for a 40 g bag of cement. The increase of antibiotic by weight raises concerns regarding structural weakening of the cement.

Moreover, and in both one-stage and two-stage re-implantation surgical protocols, the release of the antibiotic from the bone cement is completely uncontrolled. This is a significant disadvantage of both protocols and essentially acts to lengthen the time between the first and the second surgical procedures in the two-stage re-implantation process.

Thus, there remains a need in the art for a device that may be employed during re-implantation surgical procedures that may be used to deliver antibiotic in a controlled and titratable manner directly into the synovial joint cavity and adjoining medullary canals as a means of eliminating the

infection following the removal of a previous orthopedic implant. In addition, there remains a need in the art for such a device that can provide stability and maintain the physical dimensions of joint space and normal soft tissue envelope in any joint undergoing the re-implantation of an orthopedic implant. In addition, there remains a need in the art for such a device that may be easily employed, facilitates the reduction in the time needed to conduct the stage one re-implantation surgery and that reduces the overall time between the first and second stages of a two-stage re-implantation surgical protocol.

#### SUMMARY OF THE INVENTION

The present invention is directed toward an antibiotic delivery system including a device and method for treating an synovial joint and adjacent tissues, including bone, during the re-implantation of an orthopedic prosthesis. The antibiotic delivery device includes an intramedullary stem adapted to be removably mounted in a medullary canal of a bone. The stem includes an inlet adapted to be in fluid communication with a source of fluid-borne antibiotic, a plurality of outlets disposed along the stem and a channel extending between the inlet and the plurality of outlets for delivering fluid-borne antibiotic from the inlet to the plurality of outlets so as to distribute the antibiotic along the medullary canal in a controlled fashion.

In addition, the present invention is also directed toward a method of treating an infected synovial joint and adjacent tissue during a two-stage re-implantation of an orthopedic implant. The method includes the steps of removing the infected implant mounted to the medullary canal of a bone and debriding the medullary canal. An intramedullary stem is then installed into the medullary canal. The stem includes an inlet, a plurality of outlets, and a channel extending between the inlet and the plurality of outlets. In addition, the method includes the step of providing a source of fluid-borne antibiotic to the inlet of the intramedullary stem so as to distribute the antibiotic through the channel and outlets into the medullary canal in a controlled fashion.

The antibiotic delivery system of the present invention, as well as the method overcomes the disadvantages in the related art in providing a modular, implantable device designed for short-term use of approximately one week as a part of an abbreviated two-stage re-implantation technique for treatment of septic TJR of either the knee or the hip. The present invention provides structural rigidity to the joint and the limb during the period of time between the removal of an infected prosthesis and the re-insertion of a new prosthesis. This allows the patient to be mobile, while minimizing pain. The present invention also eliminates the need for an external stabilizing device, such as a cast, between the first and second stages of the re-implantation process. In addition, the system maintains joint space while acting as a temporary spacer. As explained in greater detail below, the implant assembly maintains the proper length of vital structures, including ligaments, muscles, tendons, neurovascular structures, etc., until the new prosthesis can be implanted. The system and method of the present invention act to deliver a controlled titratable antibiotic dosed directly into the synovial joint cavity and the medullary canals via an infusion system thereby attaining and maintaining much higher local joint space and tissue levels of antibiotics than can be obtained by current antibiotic spacers (static or articulating) as well as peroral/I.V.-administered antibiotics. In addition, the system and method of the present invention act to irrigate and cleanse the synovial joint and

5

medullary canals through a novel concept utilizing intermittent pulsatile leverage. In this way, the present invention facilitates the reduction in the time between the first and second stages of a two-stage re-implantation process from six to twelve weeks under the current standard of care to approximately one week.

Other objects, features, and advantages of the present invention will be readily appreciated as the same becomes better understood while reading the subsequent description taken in conjunction with the accompanying drawings.

#### BRIEF DESCRIPTION OF THE DRAWINGS

FIG. 1 is a perspective view illustrating a surgically exposed total joint replacement of a knee;

FIG. 2 is a perspective view of the antibiotic delivery system of the present invention;

FIG. 3 is an elevational view of one embodiment of an intramedullary stem of the present invention;

FIG. 4 is an end view of the distal end of the intramedullary stem illustrated in FIG. 3;

FIG. 4A is a cross-sectional view taken along lines 4A-4A of FIG. 3;

FIG. 5 is an end view of the proximal end of the intramedullary stem illustrated in FIG. 3;

FIG. 6 is an elevational view of another embodiment of the intramedullary stem of the present invention;

FIG. 7 is a top plan view of the implant assembly of the present invention;

FIG. 8 is a perspective view of the implant assembly of the present invention;

FIG. 9 is a top plan view of the implant assembly of the present invention showing the anterior half of the coupler removed;

FIG. 10 is a partial enlarged exploded view of the coupler and tibial and femoral intramedullary stems;

FIG. 11 is a side exploded view of the implant assembly of the present invention illustrating the assembly of the anterior half to the posterior half of the coupler;

FIG. 12 is a partial cross-sectional plan view illustrating the implant assembly mounted in a human knee joint;

FIG. 13 is a partial cross-sectional side view of an alternate embodiment of the femoral intramedullary stem of the present invention; and

FIG. 14 is an exploded partial cross-sectional side view of the femoral intramedullary stem illustrated in FIG. 13.

#### DETAILED DESCRIPTION OF THE INVENTION

One embodiment of an antibiotic delivery system according to the present invention is generally indicated at **110** in FIG. 2, where like numerals are used to designate like structure throughout the figures. The antibiotic delivery system **110** includes an implant assembly, generally indicated at **112**, a pump, generally indicated at **114**, and a source of fluid-borne antibiotic, generally indicated at **116**. The antibiotic implant assembly **112** forms one component of the antibiotic delivery system **110**. One of the assembly's basic components includes an intramedullary stem. One embodiment of the intramedullary stem is generally indicated at **118** in FIGS. 3-5. In the case of a total knee replacement the assembly **112** includes a tibial intramedullary stem, generally indicated at **250**, and a femoral intramedullary stem, generally indicated at **350** in FIGS. 7-12. Each of these components will be described in greater detail below.

6

More specifically, various features of the intramedullary stem will now be described with respect to the embodiment designated **118** in FIGS. 3-5. Those having ordinary skill in the art will appreciate that the features described with respect to the embodiment illustrated in these figures are also generally present in the other embodiments described below. The intramedullary stem **118** is adapted to be removably mounted into a medullary canal of a bone. The stem **118** includes an inlet **120** that is adapted to be in fluid communication with the source of fluid-borne antibiotic **116** and other appropriate fluids, as will be described in greater detail below. In addition, the stem **118** includes a plurality of outlets **122** that are disposed along the stem **118**. In addition, a channel **124** (FIG. 4A) extends between the inlet **120** and the plurality of outlets **122** for delivering fluid-borne antibiotic from the inlet **120** to the plurality of outlets **122** so as to distribute the antibiotic along the medullary canal in a controlled fashion.

In the embodiment illustrated in FIGS. 3-5, the antibiotic implant assembly **112** and the intramedullary stem **118**, per se, is particularly adapted for use in connection with the first stage of a re-implantation of a total knee replacement where the first implant has become infected. As explained in greater detail below and as illustrated in FIG. 12, the antibiotic implant assembly **112** of the present invention may also be particularly adapted for use in the first stage of a total hip replacement where the first implant has become infected. Each of these assemblies will be described in greater detail below.

Referring now specifically to the device as it is employed in connection with a re-implantation of a knee, the intramedullary stem **118** illustrated in FIGS. 3-5 defines a body, generally indicated at **126**, having a longitudinal axis A. The body **126** includes a plurality of fins **128** extending therealong and disposed in spaced angular relationship with respect to each other. In the embodiment illustrated herein, the body **126** includes four fins **128** spaced at 90° relative to one another. The fins **128** are adapted to engage the medullary canal in a removably stable fashion. However, those having ordinary skill in the art will appreciate that the body **126** of the intramedullary stem **118** may have any number of fins **128** disposed at any angle relative to each other and have any convenient shape. Alternatively, the body **126** may or may not employ fins of the type illustrated herein.

In one embodiment, the body **126** of the intramedullary stem **118** includes an intra-articular end **130** having base plate **132** disposed at the proximal end **134** of the body **126** and a distal end **136** disposed remote from the proximal end **134**. The body **126** may also have a tapered cross-section disposed along the longitudinal axis A from the proximal end **134** to the distal end **136** of the body **126** of the intramedullary stem **118**. In one embodiment, the fins **128** may have a 2° taper, gradually narrowing from the proximal end **134** to the distal end **136** of the stem. The distal end **136** may terminate in a bullet-like tip **140**. However, those having ordinary skill in the art will appreciate that the exact shape of the distal end **136** can vary and that the taper may differ from approximately 2°. Moreover, the shape and size of the distal end **136** as well as the extent of the taper may be a function of the various sizes of the stems that may be employed with patients of different sizes. Those having ordinary skill in the art will appreciate from the description herein that the body **126** of the intramedullary stem **118**, and its distal end **136**, can have any shape that facilitates stability of the implant in the medullary canal and that further facilitates the insertion and removal of the device, and that

assists in providing a press-fit of the stem in the medullary canal, so as to provide axial and rotational stability.

The inlet **120** is located in the base plate **132** of the body **126**. Similarly, the plurality of cadets **122** are disposed between the outer surface **142** of at least one of the plurality of fins **128**. In the embodiment illustrated herein, the outlets **122** are disposed along the longitudinal length of the body **126** of the intramedullary stem **118** in the valleys **144** defined between adjacent fins. The size and shape of the plurality of outlets **122** may vary depending on a number of factors including, but not limited to, the type of antibiotic fluid and other agents that pass through the stem **118**, the desired pressure and flow of the fluid-borne antibiotic, as well as various patient factors, such as age. In addition and in one embodiment, the plurality of outlets **122** may vary in size, ranging from a smaller size at the proximal end of the stem, to a larger size at the distal tip, in order to compensate for a loss in pressure. In any event, those having ordinary skill in the art will appreciate that the size, location along the body **126** of the intramedullary stem **118**, as well as the number of the outlets **122** may vary pursuant to a number of factors, all of which are within the scope of the present invention.

In the embodiment illustrated in FIGS. 3-5, the outer surface of the plurality of adjacent fins **128** is generally planer or smooth. However, another embodiment of the intramedullary system is, generally indicated at **218** in FIG. 6, where like numerals increased by 100 are used to designate like structure with respect to the stem illustrated in FIGS. 3-5. In this embodiment, the fins **228** may include longitudinally extending irregular outer surfaces **242** that are adapted to engage the medullary canal and that allow the flow of fluid-borne antibiotic between the fins **228** and the medullary canal. More specifically, in the embodiment illustrated here, the irregular surfaces **242** may define a plurality of serrations that present peaks **243** and valleys **245**, whereby the peaks **243** are in contact with the medullary canal and the valleys **245** present openings through which fluid-borne antibiotic may pass. However, those having ordinary skill in the art will appreciate that the outer surface **142**, **242** of the fins **128**, **228** may take any geometric shape that is calculated to advance the dispersion fluid-borne antibiotic throughout the medullary canal.

As noted above, the intramedullary stem of the present invention forms a part of an antibiotic implant assembly **112**. One such assembly is illustrated in FIGS. 7-12 and is particularly adapted for use in the first stage of a two-stage knee re-implantation process. To this end, the present invention may include a tibial intramedullary stem, generally indicated at **250**. The tibial intramedullary stem **250** is adapted to be removably mounted within the medullary canal of a tibia bone. Similarly, the assembly of the present invention may also include a femoral intramedullary **350** stem that is adapted to be removably mounted within the medullary canal of the femoral bone. Like reference numerals increased by 100 with respect to the intramedullary stem **118** described in FIGS. 3-5, are used to describe like structure for the tibial intramedullary stem **250**. Similarly, like reference numerals increased by 200 with respect to the intramedullary stem **118** described in FIGS. 3-5 are used to designate like structure with respect to the femoral intramedullary stem **350** illustrated in FIGS. 7-12. It should also be noted that the intramedullary stems **250**, **350** employ the structure of the outer surface **242** of the fins **228** illustrated in FIG. 6.

Like the intramedullary stem illustrated in FIGS. 3-5, the tibial intramedullary stem **250** includes a body **226** with an

intra-articular end **230** having a base plate **232** disposed at the proximal end **234** of the body and the distal end **236** disposed remote from the proximal end **234** (FIGS. 8-10). An inlet **220** (FIG. 9-11) is formed in the base plate **232** to the body **226** and a plurality of outlets **222** are disposed along the longitudinal length of the body **226**. A channel **224** (FIG. 10) extends between the inlet **220** and the plurality of outlets **222** for purposes of distributing fluid-borne antibiotic and other fluid-borne agents into the medullary canal of a tibia bone. Similarly, like the intramedullary stem **118** illustrated in FIGS. 3-5, the femoral intramedullary stem **350** includes a body **326** with an intra-articular end **330** having a base plate **332** disposed at the proximal end **334** of the body **326** and the distal end **336** disposed remote from the proximal end **334**. An inlet **320** is formed in the base plate **332** to the body **326** and a plurality of outlets **322** are disposed along the longitudinal length of the body **326**. A channel **324** (FIG. 10) extends between the inlet **320** and the plurality of outlets **322** for purposes of distributing fluid-borne antibiotic and other fluids into the medullary canal of a femur bone. From the description herein taken along with the drawings, and with the exception of the irregular outer surface of the fins, those having ordinary skill in the art will appreciate that both the tibial and femoral intramedullary stems **250**, **350** include all of the features and structural components as the intramedullary stem **118** illustrated in FIGS. 3-5 and described above.

As noted above and illustrated in FIG. 2, the implant assembly also includes a coupler, generally indicated at **410**. The coupler **410** operatively interconnects the tibial intramedullary stem **250** and the femoral intramedullary stem **350** and acts to stabilize the joint defined therebetween. The system also includes a pump, generally indicated at **114**. The pump **114** is disposed in fluid communication with the source of fluid-borne antibiotic **116** as well as other fluid-borne agents and the intramedullary stems **118**, **250**, **350** via the coupler **410**. The pump **114** acts to control the delivery of titratable fluid-borne antibiotic from the source of fluid-borne antibiotic to the inlet **120**, **220**, **320** of the intramedullary stems **118**, **250**, **350** via a conduit **412** or any suitable tubing or other delivery means. In addition, the system may also include a source of cleansing/debriding fluid. In this case, the pump **114** further acts to control the delivery of cleansing fluid in intermittent pulsatile levage fashion to the inlet **120**, **220**, **320** of the intramedullary stems, as will be described in greater detail below. In addition, the pump **114** may also be employed to remove excessive fluid from the medullary canal and surrounding tissue prior to the reintroduction of fresh antibiotic, irrigating fluid, or other fluid-borne agents into the stem, the synovial joint, and the surrounding medullary canal to facilitate the cleaning of the treated tissue. From the preceding description, those having ordinary skill in the art will appreciate that the present invention facilitates the control of a the frequency, duration, dosage and pressure of the fluid-borne antibiotic and any other agents administered by the system in a sustainable and renewable manner. Thus, the present invention facilitates a far better sterile wound bed in a much shorter time than is achievable using the current standard of care.

As best shown in FIG. 10, the coupler **410** includes an inlet **414** that is adapted for fluid communication with the source of fluid-borne antibiotic **116** as well as at least one outlet **416**, **418** in fluid communication with the inlets **220**, **320** to the tibial **250** and femoral **350** intramedullary stems. The coupler **410** acts to distribute the fluid-borne antibiotic from the source of fluid-home antibiotic **116** to the plurality of outlets **222**, **322** through the channels **224**, **324** of the

tibial and femoral intramedullary stems **230**, **350**. Likewise, those having ordinary skill in the art will appreciate that the coupler **410** also functions to distribute cleansing fluid and any other fluid-borne agents for any purpose directly into the synovial joint and into the medullary canal. In addition, as best shown in FIGS. **7**, **8** and **12**, the coupler **410** acts to hold the tibial and femoral intramedullary stems **250**, **350** rigidly together in longitudinal alignment.

More specifically and as best shown in FIGS. **9-11**, the coupler **410** may be divided into anterior **420** and posterior **422** half sections that are operatively mounted together in sealed fashion using fasteners **424** of any suitable type. Together, the anterior **420** and posterior **422** halves of the coupler **410** define a reservoir **426** disposed in fluid communication with the inlet **414** to the coupler **410** as well as the inlets **220**, **320** to the tibial and femoral intramedullary stems **250**, **350**. The coupler **410** includes a tibial stem receptacle, generally indicated at **428**, that is adapted to receive the proximal end **234** of the body **226** of the tibial intramedullary stem **250** so as to establish fluid communication between the reservoir **426** and the inlet **220** to the intramedullary stem **250**. Referring specifically to FIG. **10**, the tibial stem receptacle **428** includes an inlet port **430**, a nipple section **432**, and a transverse portion **434** extending between the inlet port **430** and the nipple **432**. The intra-articular end **234** of the intramedullary stem **250** is adapted to be snugly received in the inlet port **430**. Similarly, the base plate **232** is adapted to be received in the transverse portion **434** and the inlet **220** is adapted to be received in the nipple portion **432** of the tibial stem receptacle **428**. A gasket (not shown) may be employed at the inlet **220** to the intramedullary stem **250** to provide a proper seal between the inlet **220** of the stem **250** and the nipple portion **432** of the tibial stem receptacle **428**.

Similarly, the coupler **410** includes a femoral stem receptacle, generally indicated at **438**, adapted to receive the proximal end **334** of the body **326** of the femoral intramedullary stem **350** so as to establish fluid communication between the reservoir **426** and the inlet **320** to the femoral intramedullary stem **350**. The femoral stem receptacle **438** includes an inlet port **440**, a nipple section **442**, and a transverse portion **444** extending between the inlet port **440** and the nipple section **442**. The intra-articular end **334** of the femoral intramedullary stem **350** is adapted to be snugly received in the inlet port **440**. Similarly, the base plate **332** is adapted to be received in the transverse portion **444** and the inlet **320** is adapted to be received in the nipple section **442** of the femoral stem receptacle **438**. A gasket may also be employed at the inlet **320** to the femoral intramedullary stem **350** to establish an appropriate seal at this juncture with the nipple section **442** and the stem receptacle **438**. Other seals may be employed to make the coupler fluid-tight as necessary. Thus, the stem receptacles **428**, **438** in both ends of the coupler **410** are complementarily shaped with respect to the intra-articular ends **234**, **334** of the tibial and femoral intramedullary stems **250**, **350** such that the stems are rigidly held in place by the coupler **410** when it is fully assembled, as illustrated, for example, in FIGS. **7**, **8**, **9** and **12**.

As noted above, the tibial and femoral intramedullary stems **250**, **350** may have a 2° taper gradually narrowing from the proximal to the distal end of the device. The tibial and femoral stems **250**, **350** may have increasing lengths with each increase in stem diameter. Both the tibial and femoral stems **250**, **350** may increase in diameter by 1 mm increments from approximately 14 mm to 22 mm at the base of the stems. This allows for a "press fit" in the intramedullary canal for axial and rotational stability. The intra-

articular ends **234**, **334** of the stems may all have one standard diameter and may be solid circumferentially for an axial length, such as 25 mm so that any proximal end of any stem will fit into any coupler. In any event, those having ordinary skill in the art will appreciate that the dimensions set forth herein are merely representative and are not meant to limit the size and shape of the components of the system.

Another embodiment of the antibiotic implant assembly of the present invention is illustrated in FIGS. **14-15**. In this embodiment, the antibiotic delivery device is particularly adapted for use in stage one of a two-stage re-implantation process for a hip prosthesis. Like reference numerals increased by 400 with respect to the intramedullary stem **118** described in FIGS. **3-5**, are used to designate like structure for the femoral intramedullary stem **518**. Like the embodiment illustrated in FIGS. **3-12**, the antibiotic delivery device includes a femoral intramedullary stem **518** that is adapted to be removably mounted into a medullary canal of a femur bone. In this case, the stem **518** is mounted at the upper portion of the femur bone. The femoral intramedullary stem **518** includes a body **526** having a proximate end **534** and a distal end **536** disposed remote from the proximate end **534**. The stem **518** also includes a femoral head **560** and neck **562** extending from the proximal end **534** of the body **526** and between the body **526** and the femoral head **560**. In one embodiment, the femoral head **560** and neck **562** are modular components. In its operative mode, the femoral neck **562** will be supplied in various incremental lengths, such as 5 mm increments, so that the space between the body **526** and the femoral head **560** may be customized for any given patient to maintain soft tissue tension of the hip in order to achieve stability and resistance to dislocation of the femoral head **560** and the socket. The femoral intramedullary stem **518** also includes at least one inlet **520**, **521**. However, in the embodiment illustrated herein, the body **526** includes more than one inlet, as will be described in greater detail below. In addition, the body **526** and the femoral head **560** have a plurality of outlets **522** and a channel **524** extending between the at least one inlet **520**, **521** and the plurality of outlets **522** for delivering fluid-borne antibiotic from the inlet **520**, **521** to the plurality of outlets **522** so as to distribute the antibiotic along the intramedullary canal as well as the socket of the hip joint in a controlled fashion. In this context, those having ordinary skill in the art will appreciate that the body **526** of the femoral intramedullary stem **518** illustrated in FIGS. **14-15** may have any of the other structure and features described with respect to the stems illustrated in FIGS. **3-12** above.

In the embodiment illustrated in FIGS. **14-15**, the body **526** includes an inlet **520** and the femoral head includes a separate inlet **521**. Both inlets **520**, **521** are in fluid communication with the source of fluid-borne antibiotic **116**. The femoral head **560** has a hemispherical shape that is complementarily received in the socket of the hip joint. In its operative mode, the femoral head **560** will have a range of sizes in, for example, 1 mm increments, so that the head may be customized to fit a particular socket in any given patient. In this way, and as explained in greater detail below, the fluid-borne antibiotic is distributed directly through both the medullary canal of the femur bone as well as at the socket of the hip joint in a controlled fashion. Like the embodiment disclosed above, the flow of the antibiotic may be controlled by the pump **114**. Similarly, the pump **114** may be used to disperse any type of fluid, such as cleansing fluid, in intermittent pulsatile leverage fashion throughout the device.

In its operative mode, the antibiotic implant assembly, its individual intramedullary stems, as well as the entire system



is employed in the first stage of what is an abbreviated two-stage re-implantation process. This process begins with the removal of the infected implants and aggressive debridement of the medullary canal. As noted above, in a traditional two-stage re-implantation, an antibiotic cement spacer would be placed between the tibia and femur bones in a knee as well as the upper portion of the femur and hip socket, in connection with a re-implantation of a hip. The wound would then be closed and would heal completely in the next six to twelve weeks before the patient would return for the second stage. This extended period of time between the first and second stages is necessary, in part, because the antibiotic is distributed from the cement using elusion principles and is essentially uncontrolled.

However, in the abbreviated two-stage re-implantation employing the antibiotic delivery system of the present invention, the intramedullary stem **118, 218, 250, 350, 518** is mounted in the respective bone and provides direct antibiotic irrigation of the wound once the system is installed in both the tibia and femur (in the case of a knee replacement) or in the upper portion of the femur and hip socket (in the case of a hip replacement). Moreover, as best show in FIG. **12**, the coupler **410** in combination with the tibial and femoral intramedullary stems **250, 350** acts to stabilize the joint and provides the necessary spacing between the tibia and femur bones. The wound may be covered with a polyurethane continuously connected porous sponge (for example, Granufoam manufactured by KCI). This porous sponge also occupies deep and superficial wound space. The incisional wound edges are then completely sewn over the negative pressure wound therapy sponge except for the area just large enough to allow a suction disk to be attached to the sponge. The open area of the incision is typically about 6 cm to 8 cm in length, however, those having ordinary skill in the art will appreciate that the incision can have any suitable length. The location of the incision is proximal incision on the knee, and distal incision on the hip. An occlusive see-through dressing is then applied. This is incorporated directly over the antibiotic in flow tubing and the outgoing wound suction tubing.

The direct infusion of antibiotic, such as Vancomycin, into the infected joint cavity allows for a very high level of drug concentration to be delivered in a fast and titratable fashion. This is in contrast to solely relying on the traditional antibiotic cement spacer to release the antibiotic through elusion principles alone, which is uncontrollable and typically starts out with most of the antibiotic released within the first few days, then gradually tapering off over the next weeks to months.

The present invention also takes advantage of concentration gradients. Over a typical 24-hour period, 4 g of Vancomycin could be delivered directly into the wound bed at the site of the infection at a concentration of approximately 13.3 mg per mm. In contrast, traditional IV antibiotic delivery systems, in which 1 g of antibiotic are given every 24 hours, will achieve a serum concentration level of around 10 µg to 20 µg per mm, and even less of a level in the actual joint space itself through diffusion. Those having ordinary skill in the art will appreciate that the practice among surgeons may vary and so different types of antibiotics in different concentrations may be preferred by different surgeons under different circumstances. Nevertheless, in the example set forth above, there is a concentration difference of a 1,000 fold or more in what concentration the actual joint space itself is projected to see between the two techniques. In addition, and using the traditional two-stage technique described in the background section of this application, there

is no way to control the overall amount or rate of antibiotic elusion from the cement spacer.

The intramedullary stems **118, 218, 250, 350, 518** of the present invention may be manufactured of any suitable material. However, one suitable material of note includes a copper alloy. Copper has recently been recognized by the U.S. Environmental Protection Agency as the first solid surface material to be registered under the Federal Insecticide, Fungicide and Rodenticide Act. According to the EPA registration, certain copper alloys continuously reduce bacterial contamination achieving approximately 99.9% reduction within two hours of exposure. In addition, copper alloys can also kill greater than 99.9% of bacteria within two hours of exposure. Moreover, certain copper alloys deliver continuous and ongoing antibacterial action, even after repeated wear and re-contamination. Those having ordinary skill in the art will appreciate that many different types of copper alloys may be suitable for this purpose. However, in order for the alloys to have antibacterial properties, it is believed that they must contain at least 65% copper. As presently best understood, there are currently 48 cast alloys which are included in the Group II Copper Alloys which have between 85% and 95% copper. In any event, those having ordinary skill in the art will appreciate that the present invention is not limited to any specific copper alloy or any particular material.

Like the stems, in one preferred embodiment the coupler **410** may also be metallic and may be manufactured using a copper alloy. Multiple couplers may be available, each having a variable thickness and transverse dimension that act to separate the abutting ends of the stems by, for example 5 mm increments, to allow the distance between the tibial and femoral stems to be customized in order to allow proper distraction of the joint cavity (for example between 25 mm and 40 mm), until the desired tension on the ligaments could be obtained. As noted above, in addition to the pump delivering the antibiotic fluid, the system **110** may also employ a negative pressure wound therapy to remove antibiotic irrigation fluid and to aid in the eradication of infection through principles unique to that technology.

The antibiotic delivery system **110** and the associated implant **112** assembly of the present invention overcomes the disadvantages in the related art in providing a modular, implantable device designed for short-term use of approximately one week as a part of an abbreviated two-stage re-implantation technique for treatment of a septic (infected) TJR of either the knee or the hip. The present invention provides structural rigidity to the joint and the limb during the period of time between the removal of an infected prosthesis and the re-insertion of a new prosthesis. This allows the patient to be mobile, while minimizing pain. In addition, the implant assembly **112** maintains joint space while acting as a temporary spacer. This maintains proper length of vital structures, including ligaments, muscles, tendons, neurovascular structures, etc., until the new prosthesis can be implanted. The system **110** and the individual components thereof act to deliver a controlled and titratable antibiotic dosed directly into the synovial joint cavity and medullary canals via an infusion system. In addition, the system and its components act to irrigate and cleanse the medullary canals through a novel concept utilizing intermittent pulsatile leverage.

The present invention has been described in an illustrative manner. It is to be understood that the terminology that has been used is intended to be in the nature of words of description rather than of limitation. Many modifications and variations of the present invention are possible in light

of the above teachings. Therefore, within the scope of the appended claims, the present invention may be practiced other than as specifically described. In addition, those having ordinary skill in the art will appreciate from the foregoing description, taken along with the drawings, that the term "system" as used in the claims may encompass individual components of the system, such as the intramedullary stems, the implant assembly for both a knee and hip, as well as the entire system, including the implant assembly, the pump, and the source of antibiotic fluid. Thus, the term "system" as it is used in the claims does not necessarily encompass all of the components of the system and, depending on the scope of the individual claims, may refer to merely a subcomponent of that system.

What is claimed is:

**[1.** An antibiotic delivery system comprising:

a femoral intramedullary stem adapted to be removably mounted into a medullary canal of a femur bone, said femoral intramedullary stem including a body having a proximate end and a distal end disposed remote from said proximate end, said body including a plurality of fins extending therealong and disposed in spaced angular relationship with respect to each other so as to define valleys that provide fluid flow spaces disposed between adjacent fins, said fins adapted to engage said medullary canal in a removably stable fashion, a femoral head and a neck extending from said proximal end of said body and between said body and said femoral head, said femoral intramedullary stem including at least one inlet, and a plurality of outlets disposed along said stem and between an outer surface of one of said plurality of adjacent fins in said valleys and in fluid communication with said fluid flow spaces and a channel extending between said inlet and said plurality of outlets, said femoral head having a plurality of outlets and a channel extending between said at least one inlet and said plurality of outlets for delivering fluid-borne antibiotics from said at least one inlet to said plurality of outlets so as to distribute said antibiotic along said intramedullary canal and the socket of a hip joint in a controlled fashion.]

**[2.** An antibiotic delivery system as set forth in claim 1, wherein said body includes an inlet and said femoral head includes an inlet, both inlets being in fluid communication with a source of fluid-borne antibiotic.]

**[3.** An antibiotic delivery system as set forth in claim 1, wherein said femoral head has a hemispherical shape so as to be complementarily received in the socket of a hip joint.]

**4.** A method of treating an infected joint during a two-stage re-implantation of an orthopedic implant, said method comprising the steps of:

removing [the] infected implants mounted to the medullary canal of a bone;

debriding the medullary canal; and

installing an intramedullary stem into the medullary canal where the stem includes an inlet, a plurality of outlets and a channel extending between the inlet and the plurality of outlets, *wherein installing the intramedullary stem includes installing a tibial intramedullary stem into the medullary canal of the tibia bone and installing a femoral intramedullary stem into the medullary canal of a femur bone;*

said *intramedullary stem* including a plurality of fins extending along a longitudinal axis of the *intramedullary stem* and disposed in spaced angular relationship with respect to each other so as to define valleys that provide fluid flow spaces disposed between adjacent

fins and a plurality of outlets disposed along said *intramedullary stem* and between an outer surface of one of said plurality of adjacent fins in said valleys and in fluid communication with said fluid flow spaces providing a source of fluid-borne antibiotic to the inlet of the intramedullary stem so as to distribute the antibiotic into the medullary canal in a controlled fashion.

**[5.** A method of treating an infected orthopedic implant as set forth in claim 4, wherein said step of installing an intramedullary stem includes installing a tibial intramedullary stem into the medullary canal of the tibia bone and installing a femoral intramedullary stem into the medullary canal of a femur bone.]

**6.** A method of treating an infected [orthopedic implant] joint as set forth in claim [5] 4, wherein the method further includes [the step of] positioning a coupler between the tibial intramedullary stem and the femoral intramedullary stem so as to provide axial stability between the tibial and femoral intramedullary stems.

**7.** A method of treating an infected [orthopedic implant] joint as set forth in claim 6, wherein the method further includes [the step of] establishing fluid communication between the coupler and the inlet of the tibial and femoral intramedullary stems and providing fluid communication between the coupler and [a] the source of fluid-borne antibiotic so as to distribute the antibiotic through the tibial and femoral intramedullary stems and along the medullary canals in a controlled fashion.

*8. A method of treating an infected area of bone comprising a first bone and a second bone, said method comprising: removing an infected intramedullary implant from the first bone;*

*disposing a first intramedullary implant in a medullary canal of the first bone, wherein the implant comprises an outer surface, an inlet, a plurality of outlets in fluid communication with the inlet, and a channel in fluid communication with the inlet and the plurality of outlets;*

*delivering a fluid from the plurality of outlets to the medullary canal of the first bone in a controlled fashion, wherein the plurality of outlets are disposed in one or more valley regions in the outer surface of the first intramedullary implant;*

*removing a second infected intramedullary implant from the second bone in the infected area;*

*disposing a second intramedullary implant in a second medullary canal of the second bone, wherein the second implant comprises an outer surface, an inlet, a plurality of outlets in fluid communication with the inlet, and a channel in fluid communication with the inlet and the plurality of outlets; and*

*delivering the fluid from the plurality of outlets to the second medullary canal of the second bone in a controlled fashion, wherein the plurality of outlets are disposed in one or more valley regions in the outer surface of the second intramedullary implant.*

**9.** The method of claim 8, wherein the first bone comprises a femur or a tibia.

**10.** The method of claim 8, wherein disposing the first intramedullary implant in the medullary canal of the first bone comprises engaging a plurality of fins disposed on the first intramedullary implant with bone lining the intramedullary canal of the first bone.

## 15

11. The method of claim 8, wherein the first implant comprises a head coupled thereto, the head having a plurality of outlets fluidly coupled to the channel, the method further comprising:

disposing the head in a bone socket; and  
delivering the fluid from the plurality of outlets in the head to the bone socket in a controlled fashion.

12. The method of claim 8, wherein the head comprises a hemispherically shaped head.

13. The method of claim 8, wherein the fluid comprises an antibiotic, an antibacterial, or an irrigation fluid.

14. The method of claim 8, further comprising applying negative pressure wound therapy to the infected area.

15. The method of claim 8, wherein removing the infected intramedullary implant from the first or the second bone comprises removing a prosthetic joint from the first bone.

16. The method of claim 15, wherein the prosthetic joint comprises a prosthetic hip joint or a prosthetic knee joint.

17. The method of claim 8, further comprising coupling the first intramedullary implant to the second intramedullary implant with a coupler.

18. A system for delivering fluid to an infected area of bone having a first bone, said system comprising:

a first intramedullary implant configured to be disposed in a medullary canal of the first bone, wherein the first implant comprises an outer surface, an inlet, a plurality of outlets in fluid communication with the inlet, and a channel in fluid communication with the inlet and the plurality of outlets,

wherein the plurality of outlets are disposed in one or more valley regions of the outer surface;

a source of fluid in fluid communication with the channel, wherein the fluid is delivered to the medullary canal via the plurality of outlets; and

a second intramedullary implant configured to be disposed in a medullary canal of a second bone, wherein the second implant comprises an outer surface, an inlet, a plurality of outlets in fluid communication with

## 16

the inlet, and a channel in fluid communication with the inlet and the plurality of outlets,

wherein the plurality of outlets are disposed in one or more valley regions of the outer surface of the second intramedullary implant, and

wherein the source of fluid is in fluid communication with the channel of the second intramedullary implant, and wherein the fluid is delivered to the medullary canal of the second bone via the plurality of outlets of the second intramedullary implant.

19. The system of claim 18, wherein the first intramedullary implant comprises a femoral implant configured to be disposed in the medullary canal of a femur, or wherein the first intramedullary implant comprises a tibial implant configured to be disposed in the medullary canal of a tibia.

20. The system of claim 18, further comprising a coupler for coupling the first intramedullary implant to the second intramedullary implant.

21. The system of claim 18, wherein the first implant comprises a head coupled thereto, the head having a plurality of outlets fluidly coupled to the channel, wherein the head is configured to be disposed in a socket of a joint, and wherein the fluid is delivered to the socket in a controlled fashion via the plurality of outlets in the head.

22. The system of claim 21, wherein the head comprises a hemispherically shaped head.

23. The system of claim 18, wherein the fluid comprises an antibiotic, antibacterial, or an irrigation fluid.

24. The system of claim 18, further comprising a pump, wherein the pump pumps the fluid from the source of the fluid to the plurality of outlets.

25. The system of claim 18, further comprising a pump for applying negative pressure wound therapy to the infected area.

26. The system of claim 18, wherein the first intramedullary implant comprises a plurality of fins disposed thereon.

\* \* \* \* \*

UNITED STATES PATENT AND TRADEMARK OFFICE  
**CERTIFICATE OF CORRECTION**

PATENT NO. : RE46,283 E  
APPLICATION NO. : 14/817103  
DATED : January 24, 2017  
INVENTOR(S) : de Beaubien

Page 1 of 1

It is certified that error appears in the above-identified patent and that said Letters Patent is hereby corrected as shown below:

In the Specification

Column 1, beginning at Line 15, replace the heading "CROSS-REFERENCE TO RELATED APPLICATION(S)" and the paragraph below the heading with the following:

*Notice: More than one reissue application has been filed for the reissue of U.S. Patent No. 8,900,322. The reissue applications are U.S. Reissue Patent Application Serial No. 15/846,021, filed on December 18, 2017, which is a continuation reissue application of U.S. Reissue Patent Application Serial No. 15/336,472, filed on October 27, 2016, now U.S. Reissue Patent No. RE46,669 E, issued January 16, 2018, which is a continuation reissue application of U.S. Reissue Patent Application Serial No. 14/817,103 (the present application), filed on August 3, 2015, now U.S. Reissue Patent No. RE46,283 E, issued January 24, 2017.*

*CROSS-REFERENCE TO RELATED APPLICATION(S)*

*U.S. Patent Application Serial No. 13/759,239, filed February 5, 2013, now U.S. Patent No. 8,900,322, issued December 2, 2014, is a divisional application of U.S. Patent Application No. 12/712,748, filed February 25, 2010, now U.S. Patent No. 8,454,706, issued June 4, 2013, entitled "Antibiotic Delivery System and Method for Treating an Infected Synovial Joint During Re-implantation of an Orthopedic Prosthesis," which claims the benefit of U.S. Provisional Patent Application No. 61,208,540, filed February 25, 2009, now expired, entitled "Joint Purification Systems,".*

Signed and Sealed this  
Twelfth Day of June, 2018

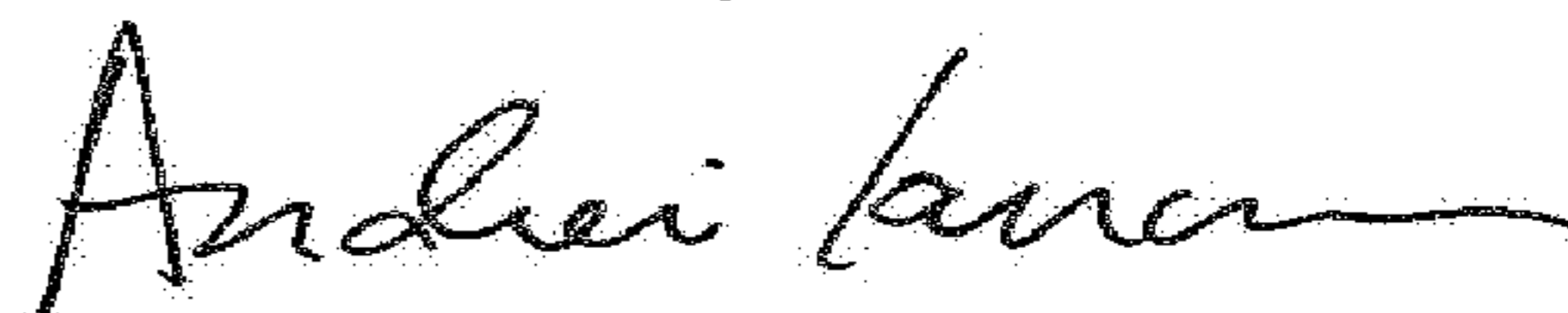

Andrei Iancu  
Director of the United States Patent and Trademark Office