



US00RE46262E

(19) **United States**
(12) **Reissued Patent**
Park et al.

(10) **Patent Number: US RE46,262 E**
(45) **Date of Reissued Patent: Jan. 3, 2017**

(54) **OPTICAL IMAGING SYSTEM**

(56) **References Cited**

(71) Applicant: **SAMSUNG ELECTRONICS CO., LTD.**, Suwon-si, Gyeonggi-do (KR)

U.S. PATENT DOCUMENTS

(72) Inventors: **Seong-Ha Park**, Suwon-si (KR);
Ki-Tae Kim, Seongnam-si (KR)

4,095,873	A *	6/1978	Takahiro	359/723
5,050,973	A	9/1991	Sakamoto	
5,859,729	A	1/1999	Misaka	359/686
6,236,522	B1	5/2001	Shimizu	
6,288,850	B1 *	9/2001	Otomo	359/773
6,898,030	B1	5/2005	Lin et al.	
7,190,532	B2 *	3/2007	Amanai	359/781
7,206,143	B2	4/2007	Kamo et al.	
2004/0012861	A1 *	1/2004	Yamaguchi	359/772
2004/0027685	A1 *	2/2004	Mihara et al.	359/686
2004/0136097	A1	7/2004	Park	359/773
2004/0218285	A1	11/2004	Amanai	
2004/0228009	A1	11/2004	Kamo et al.	

(73) Assignee: **Samsung Electronics Co., Ltd.**, Suwon-si (KR)

(21) Appl. No.: **14/153,566**

(22) Filed: **Jan. 13, 2014**

Related U.S. Patent Documents

Reissue of:

(64) Patent No.: **7,466,497**
Issued: **Dec. 16, 2008**
Appl. No.: **11/473,154**
Filed: **Jun. 21, 2006**

FOREIGN PATENT DOCUMENTS

CN	1627118	6/2005
JP	2005-1027	1/2002

U.S. Applications:

(62) Division of application No. 12/970,720, filed on Dec. 16, 2010, now Pat. No. Re. 44,773, which is an application for the reissue of Pat. No. 7,466,497.

OTHER PUBLICATIONS

Park, Young-Woo; Patent Application Publication No. US 2004/0136097 A1; Publication Date: Jul. 15, 2004; "Photographing Lens;"

(30) **Foreign Application Priority Data**

Jul. 7, 2005 (KR) 10-2005-0061174

Primary Examiner — Deandra Hughes

(74) *Attorney, Agent, or Firm* — Drinker Biddle & Reath LLP

(51) **Int. Cl.**
G02B 9/34 (2006.01)
G02B 9/36 (2006.01)
G02B 13/00 (2006.01)

(57) **ABSTRACT**

An optical imaging system is provided comprising a first lens group having a positive refractive power; a second lens group having a negative refractive power; a third lens group having a positive or negative power; and a fourth lens group having a positive or negative power.

(52) **U.S. Cl.**
CPC . **G02B 9/34** (2013.01); **G02B 9/36** (2013.01);
G02B 13/004 (2013.01)

(58) **Field of Classification Search**
CPC G02B 9/34; G02B 13/004
USPC 359/715, 723, 771-775
See application file for complete search history.

47 Claims, 14 Drawing Sheets

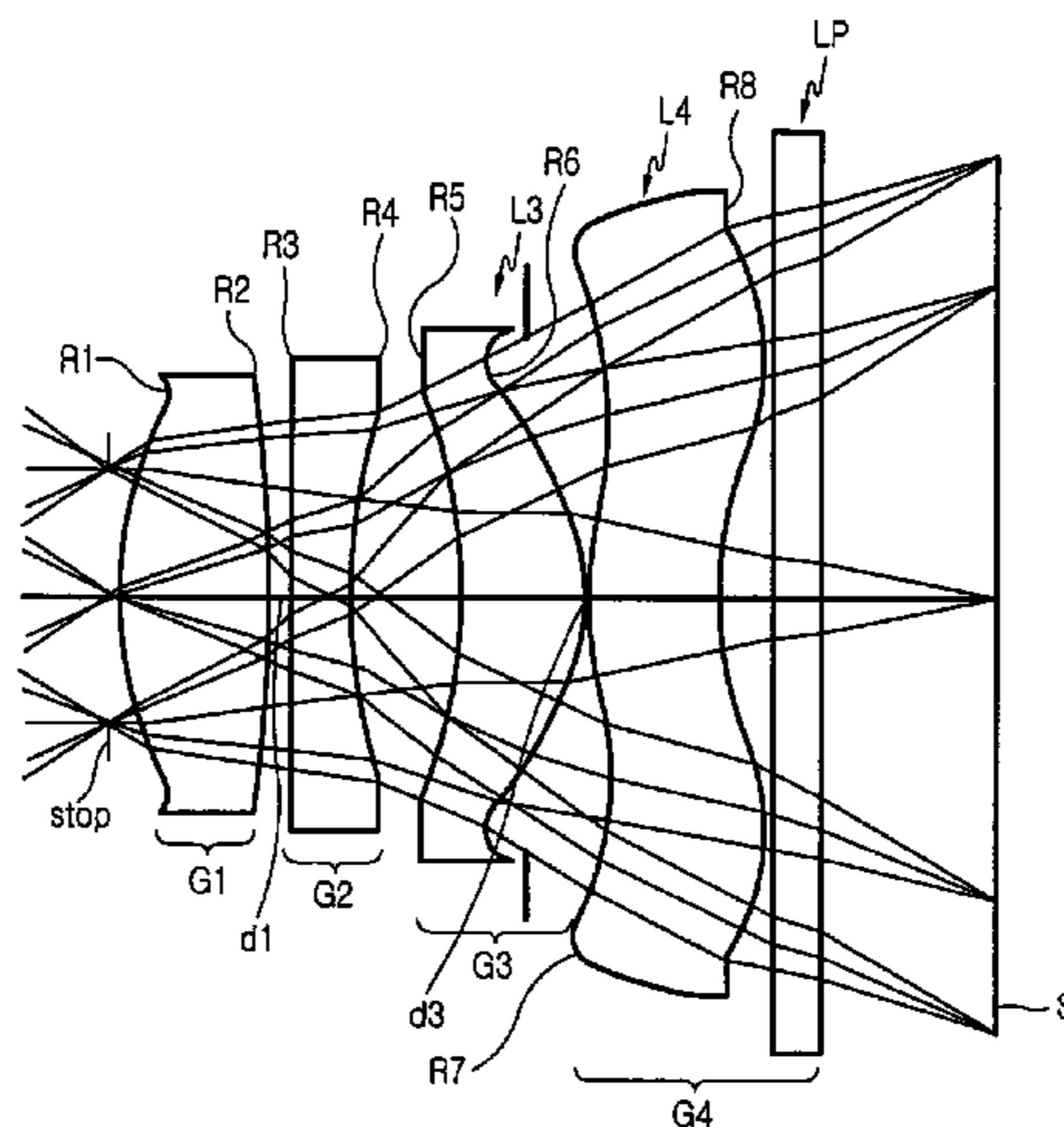

(56)

References Cited

U.S. PATENT DOCUMENTS

2005/0024748	A1	2/2005	Amanai	
2005/0105194	A1*	5/2005	Matsui et al.	359/772
2005/0117047	A1*	6/2005	Isono	348/335
2006/0056068	A1*	3/2006	Lee et al.	359/781

* cited by examiner

10

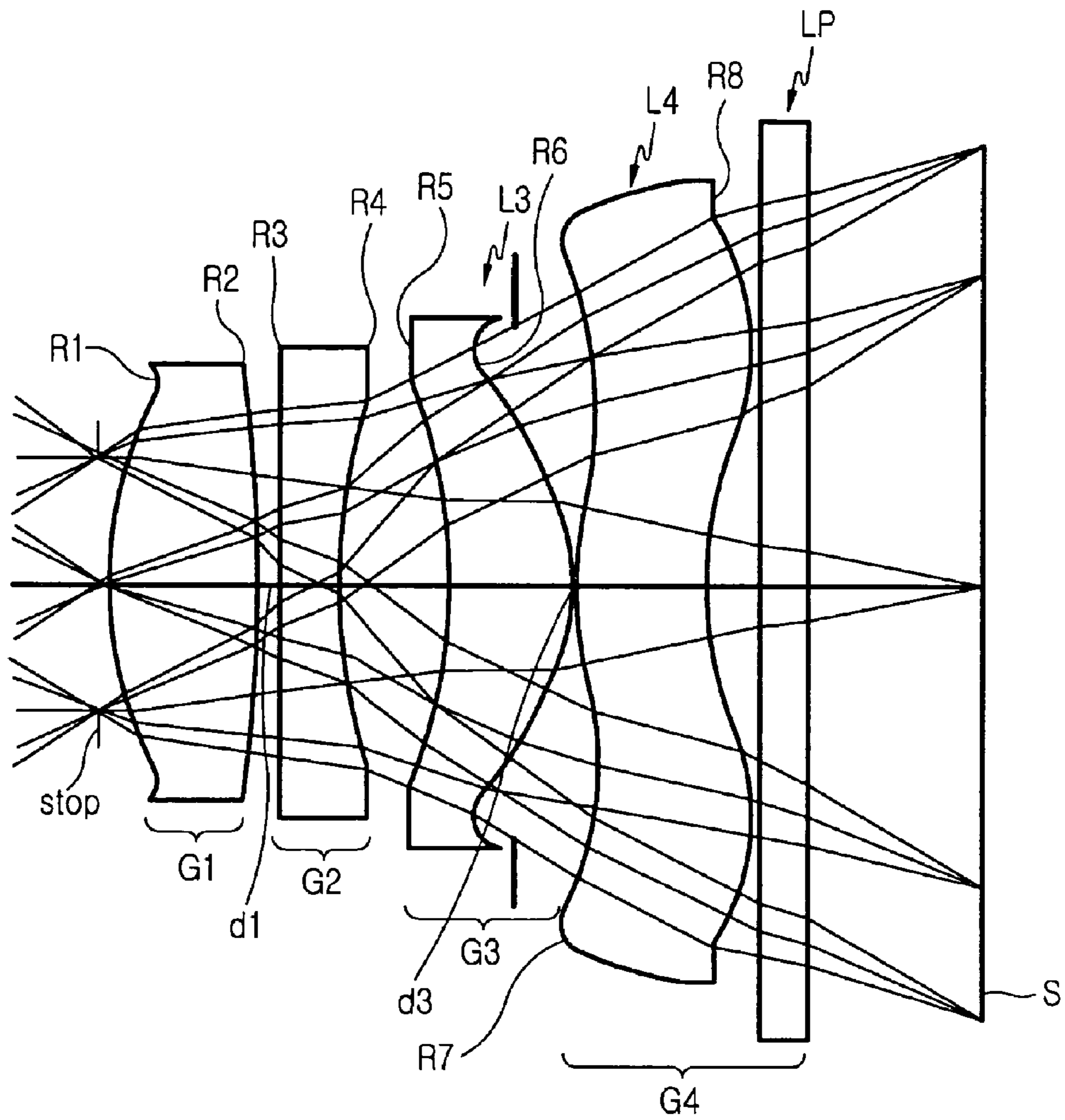

FIG.1

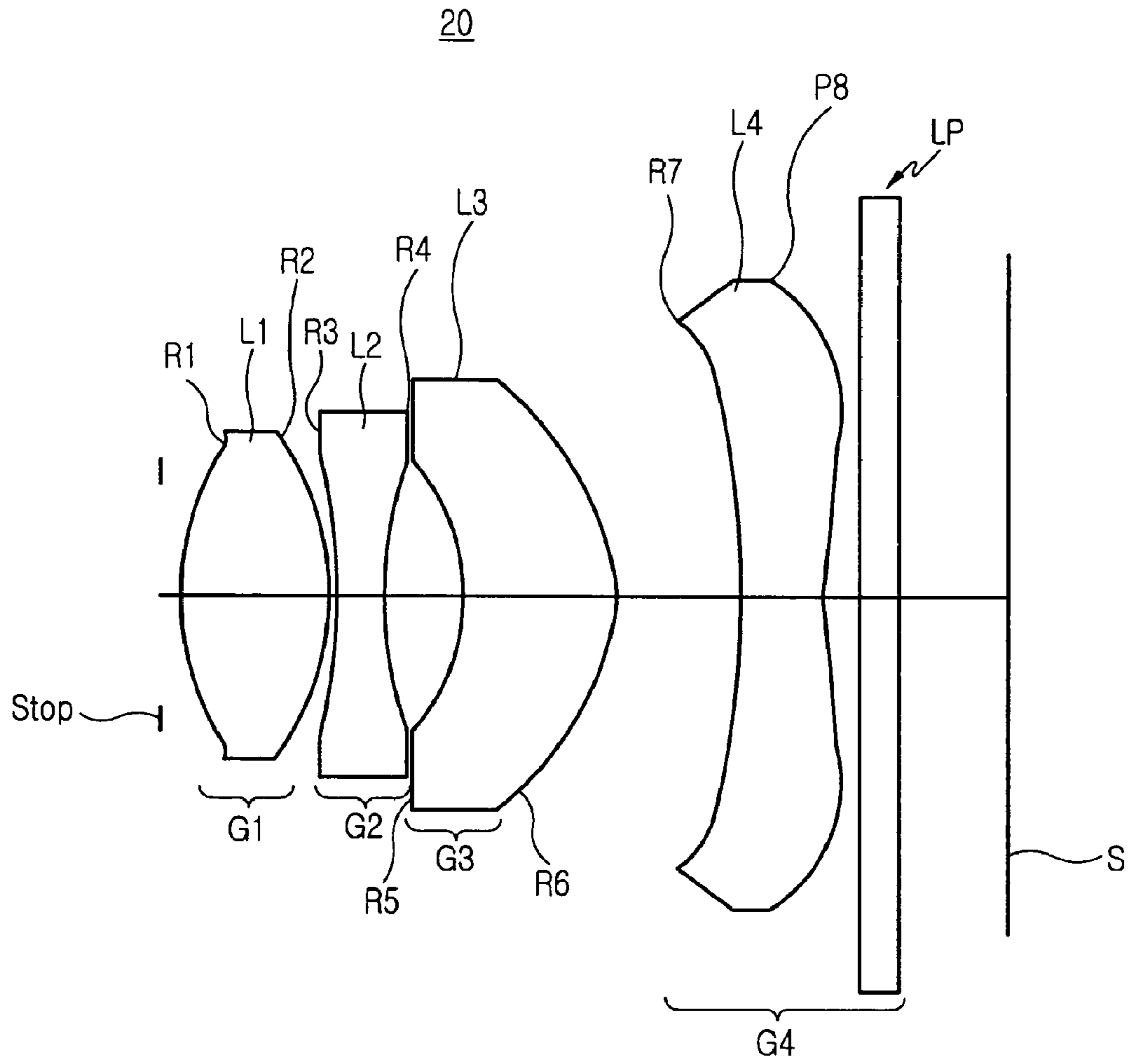

FIG.2

30

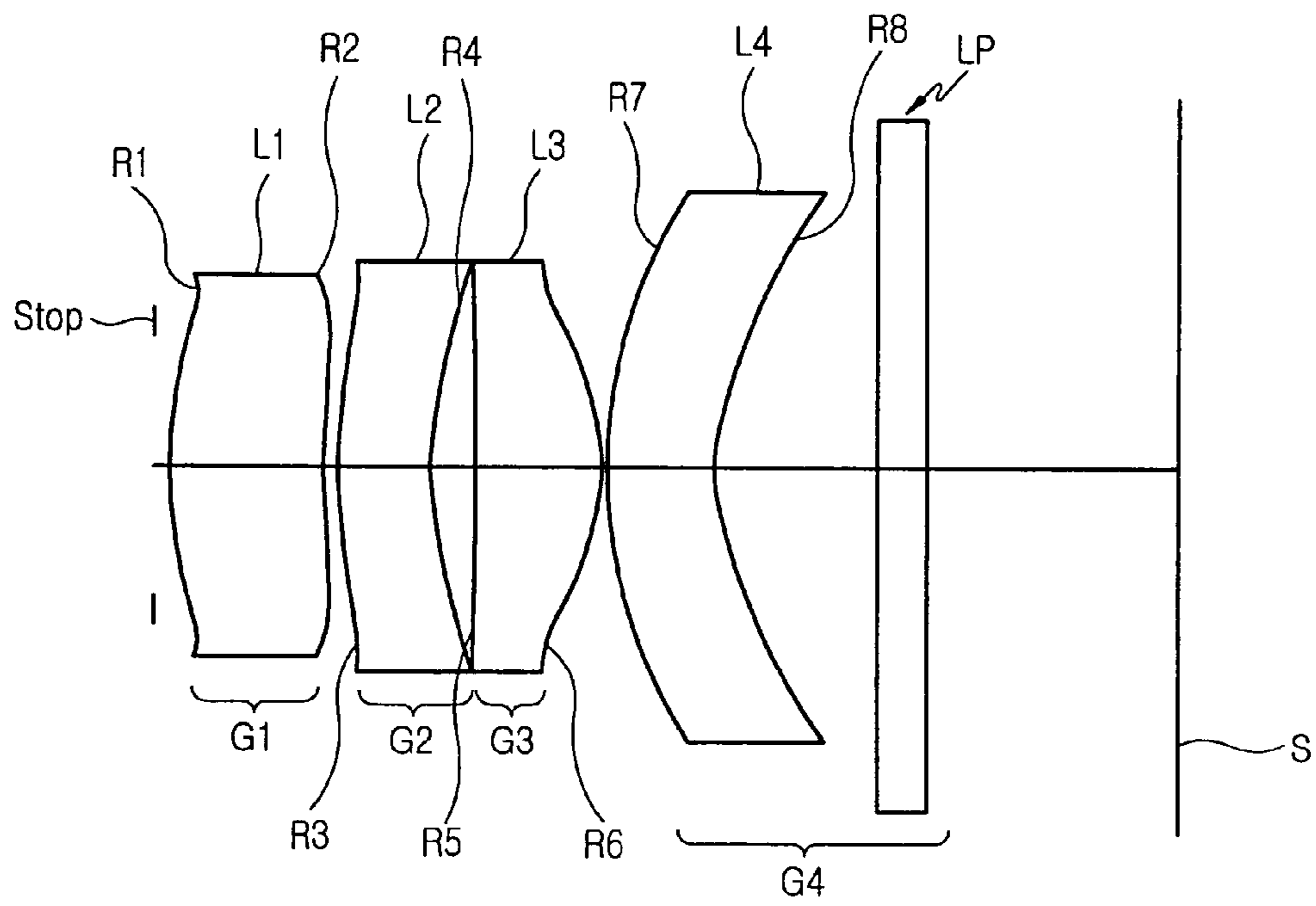

FIG.3

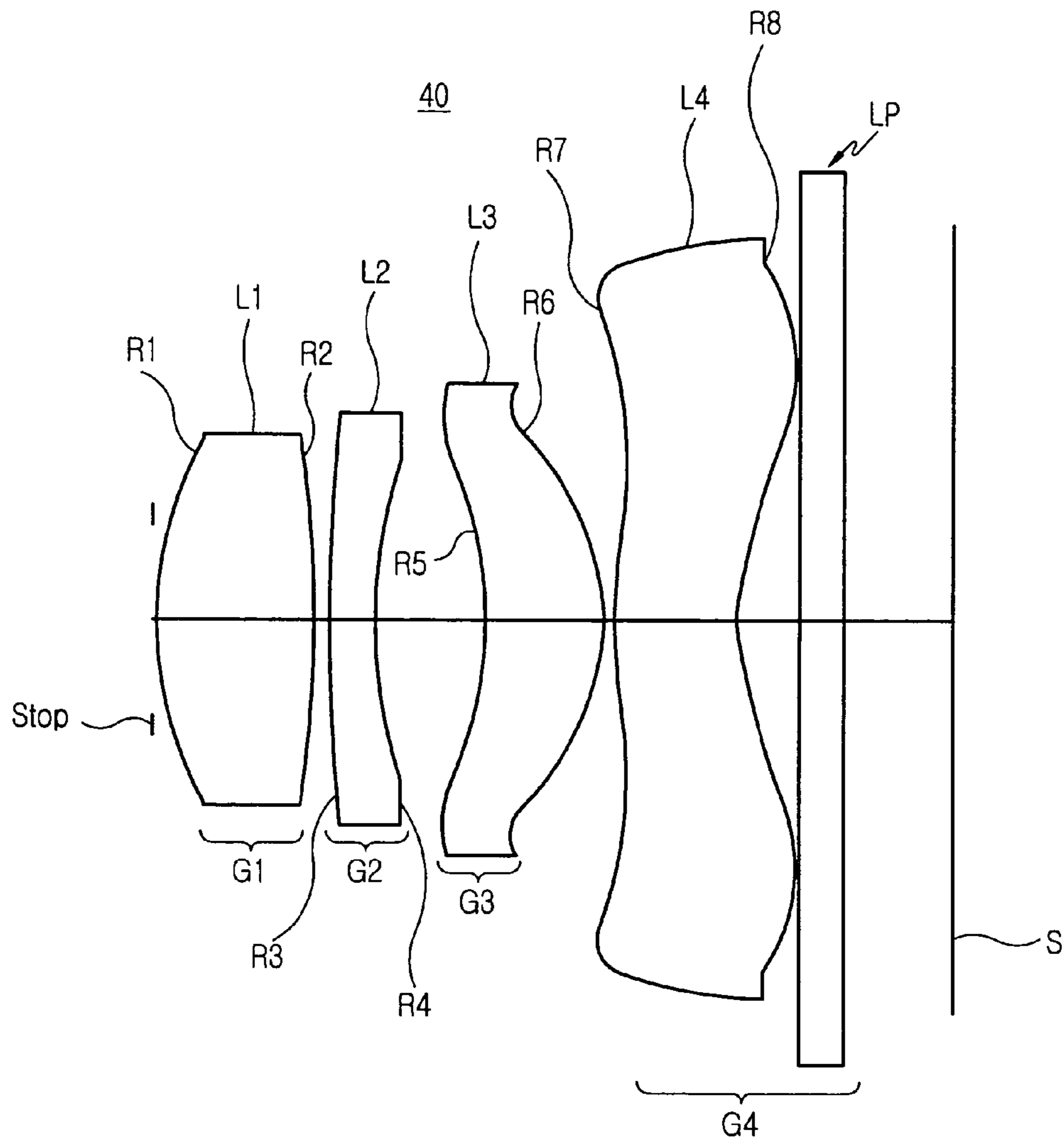

FIG.4

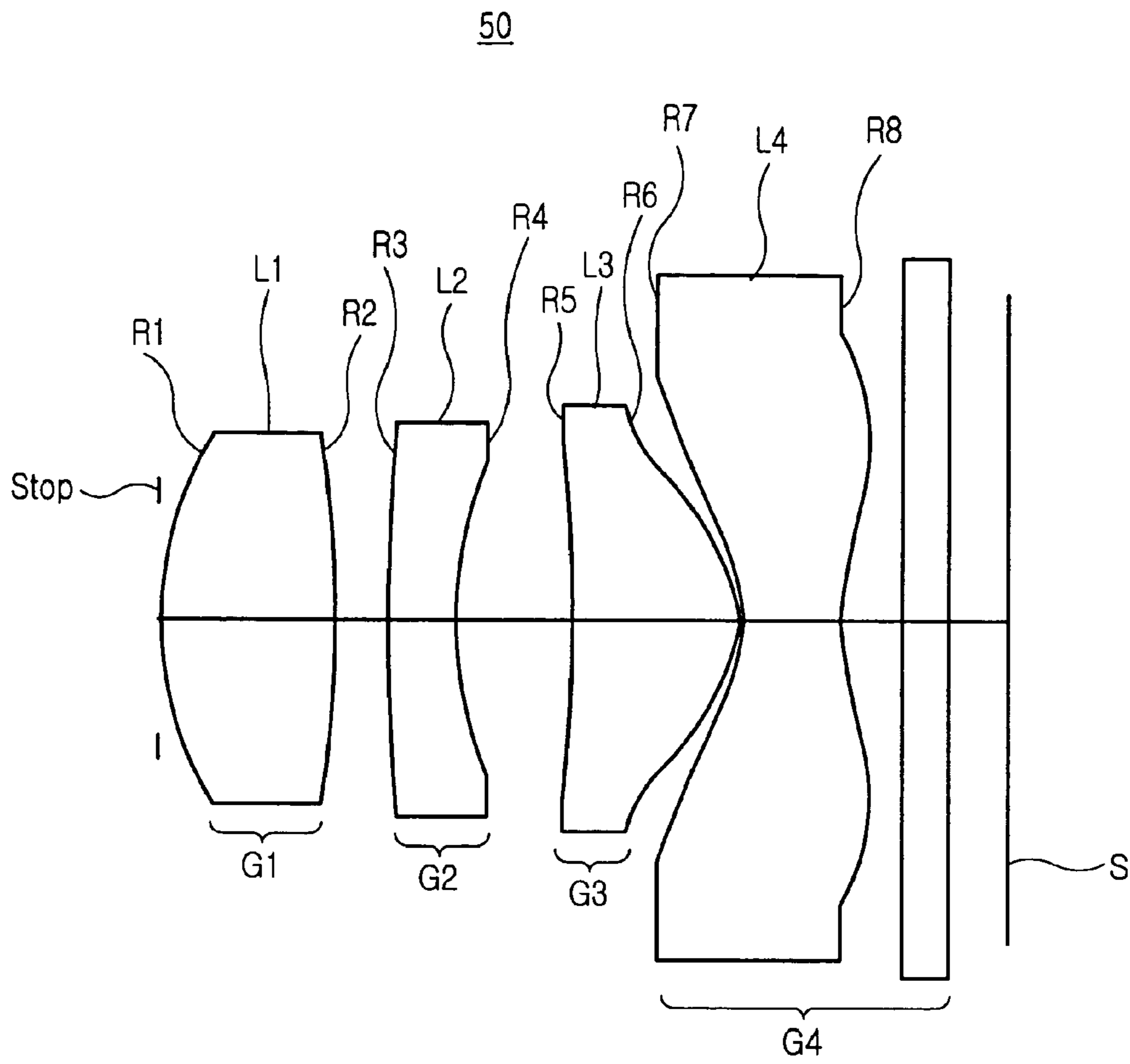

FIG.5

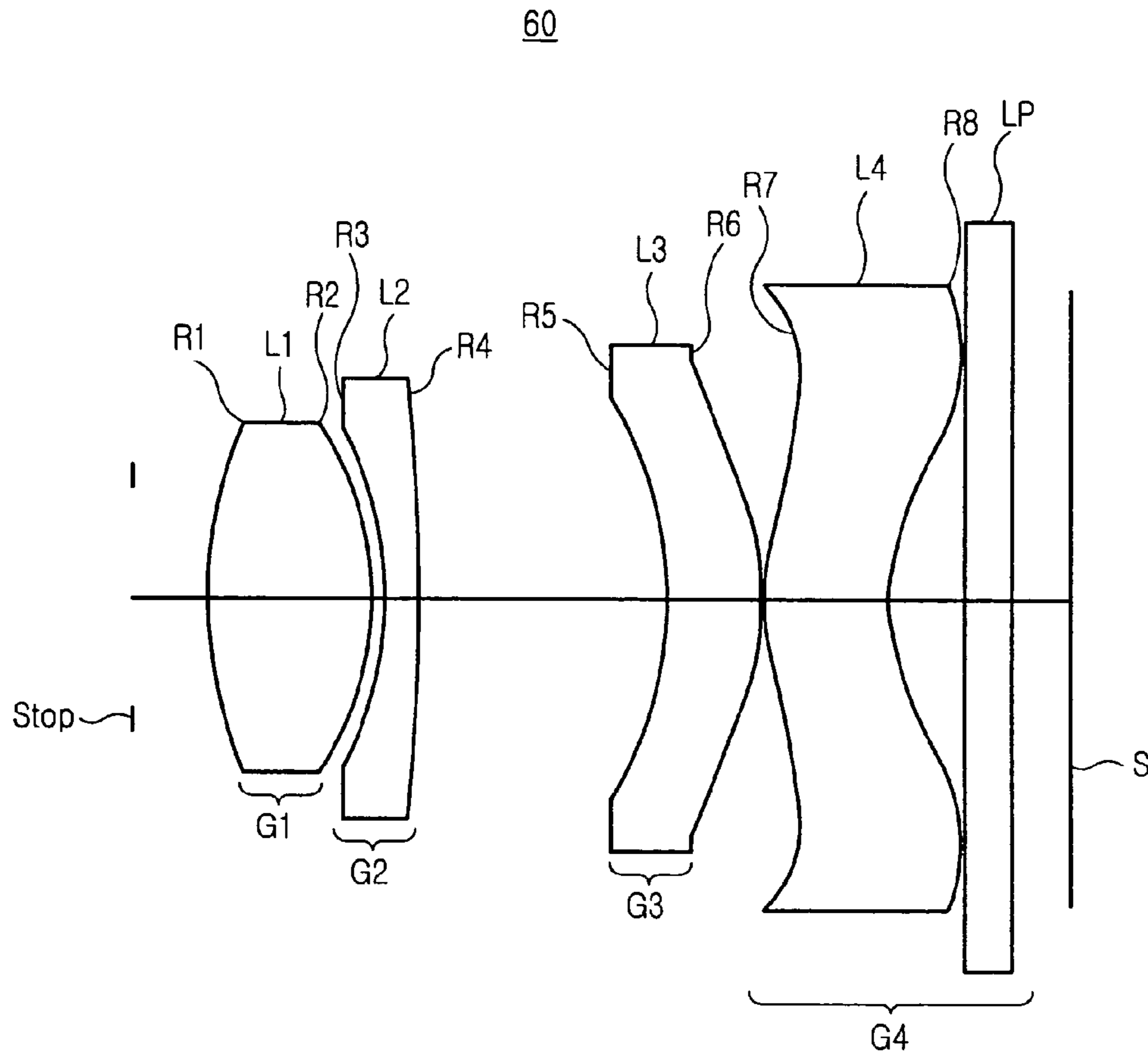

FIG.6

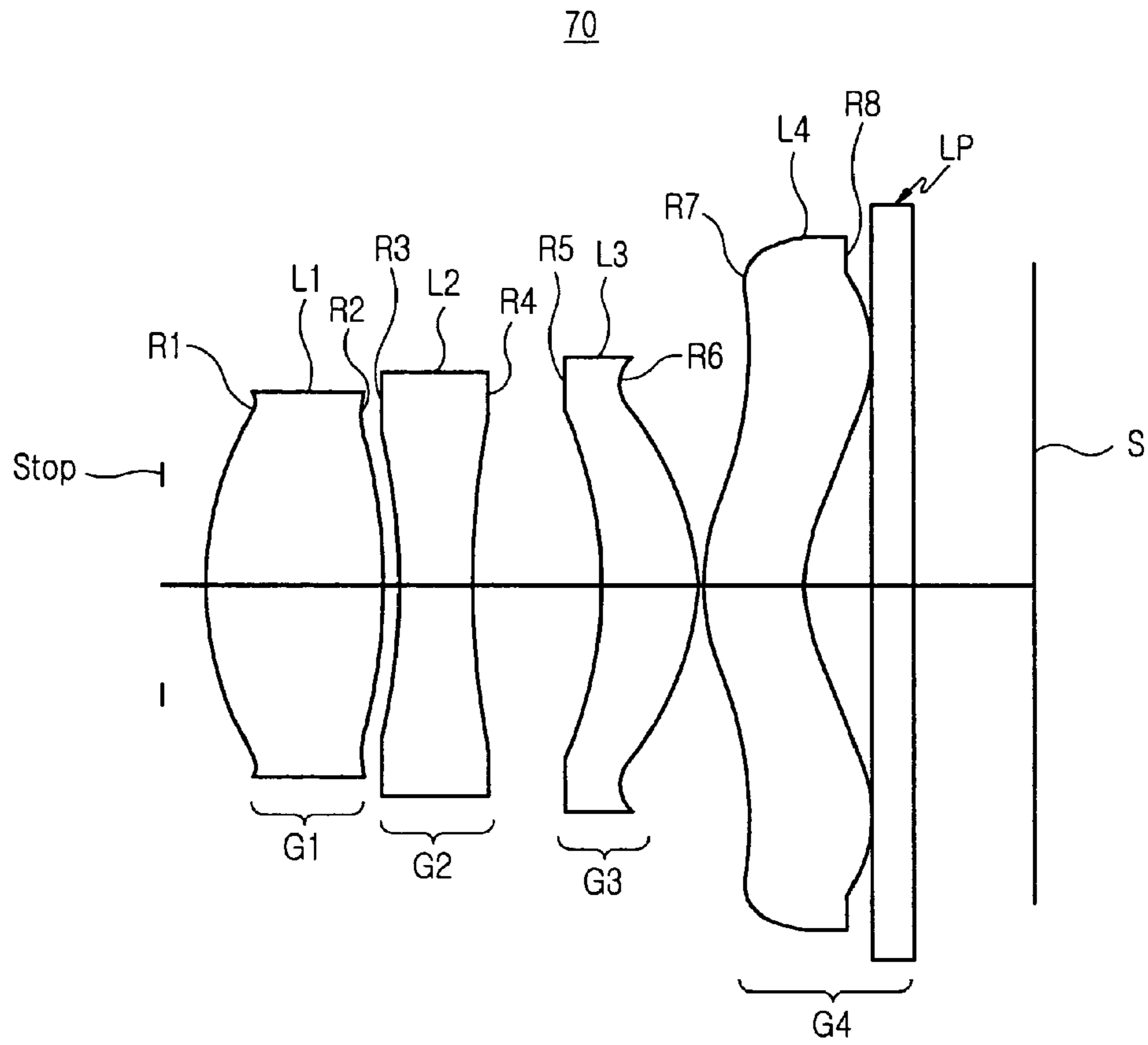

FIG.7

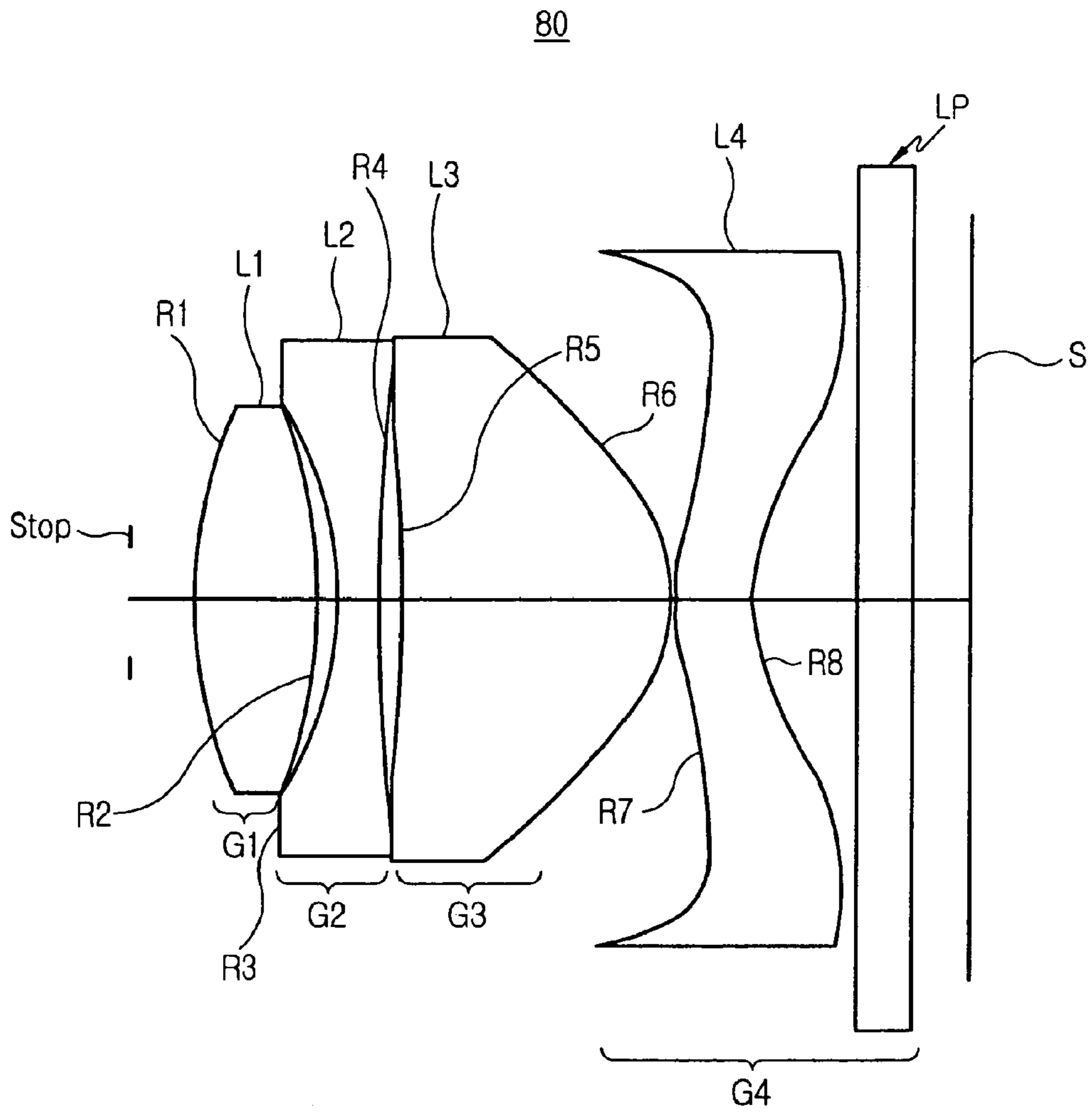

FIG.8

90

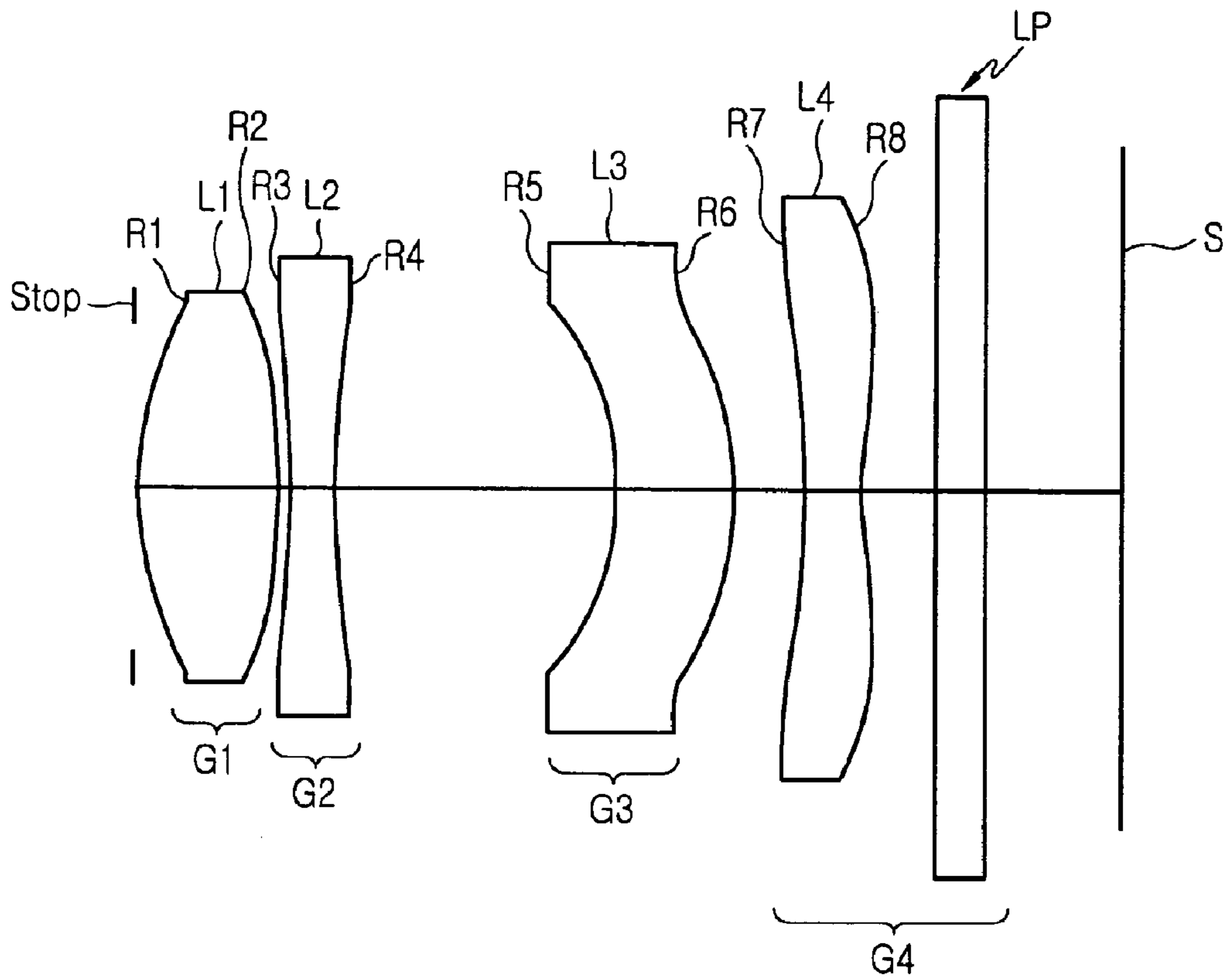

FIG.9

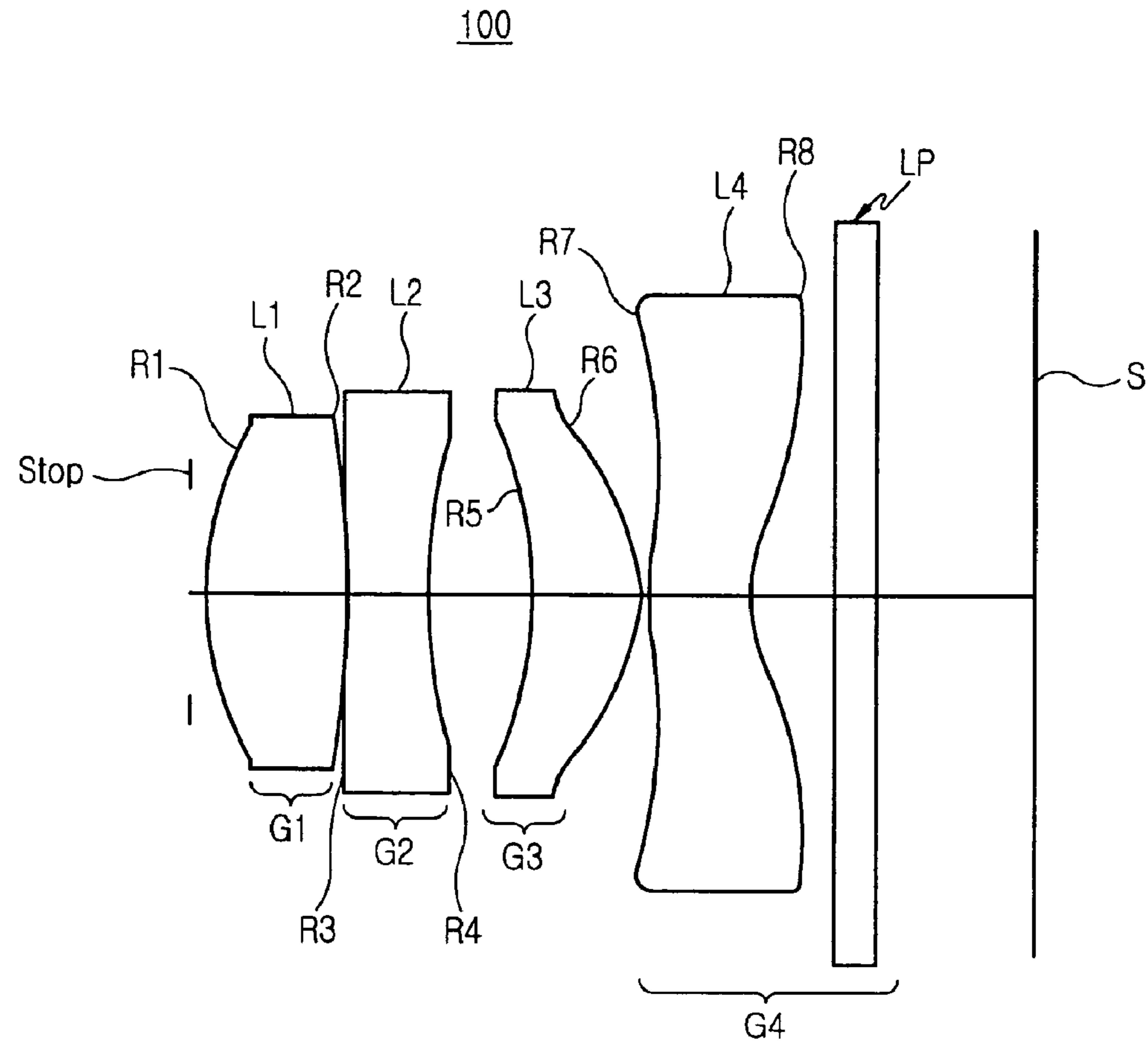

FIG.10

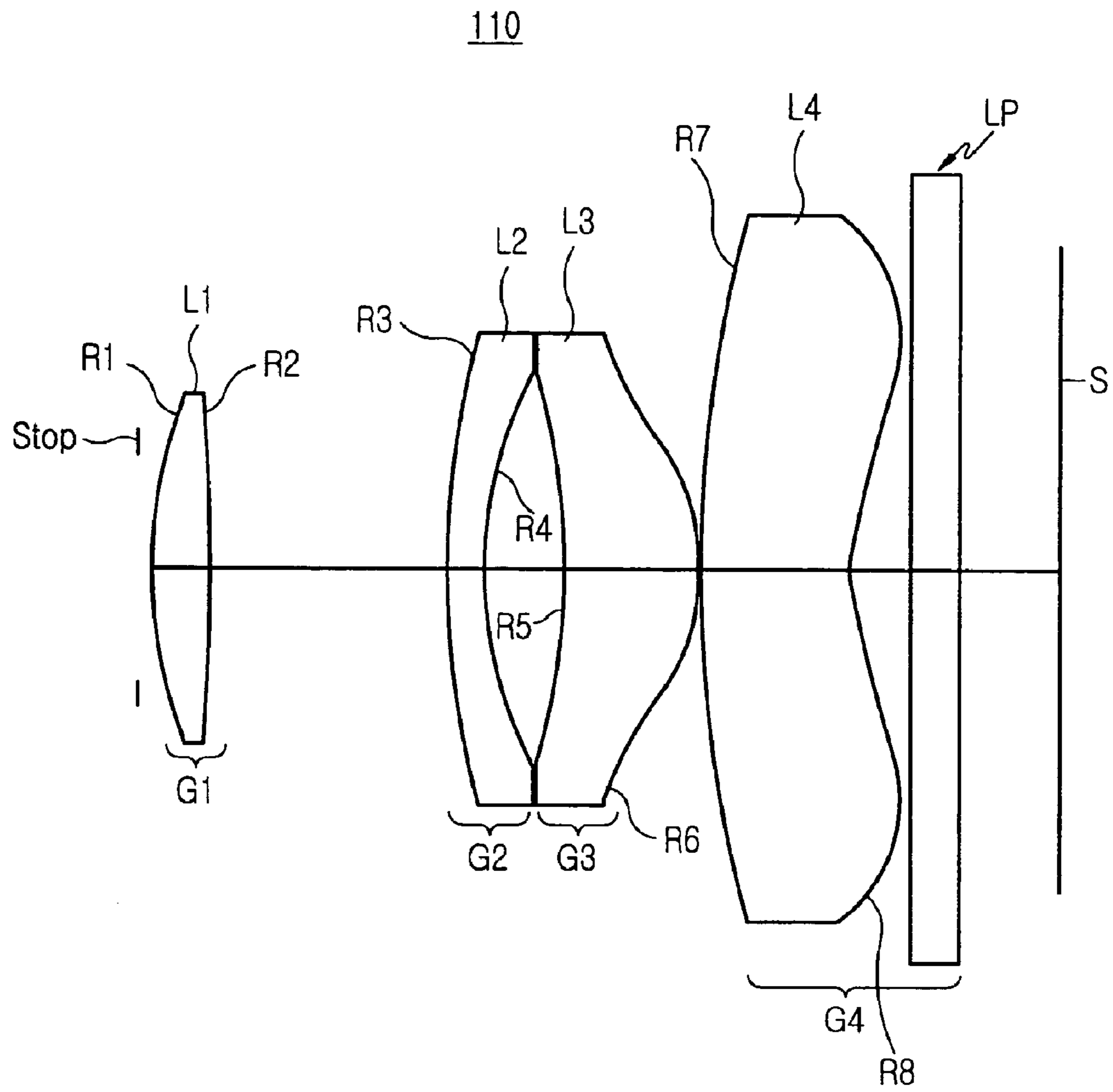

FIG. 11

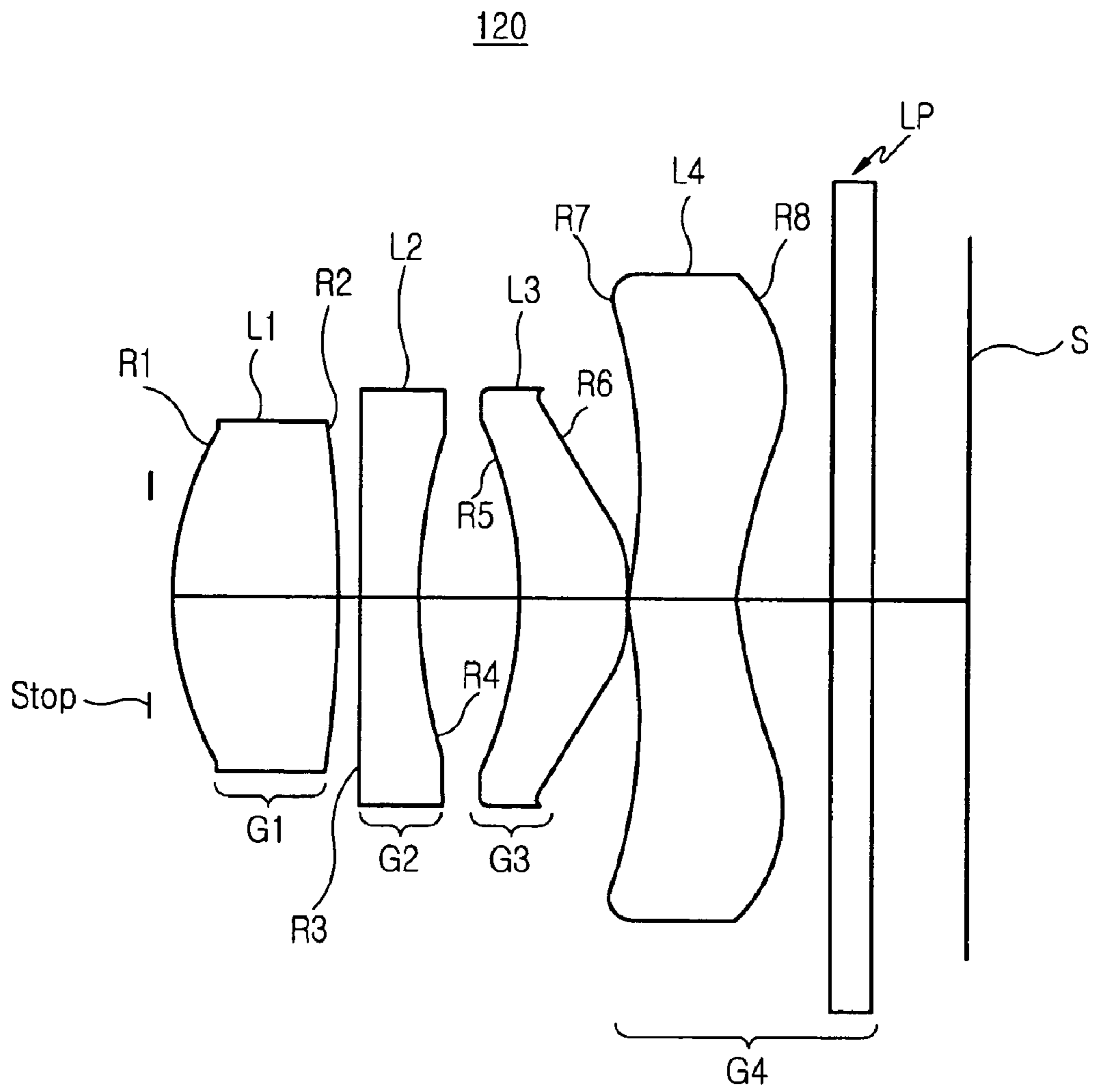

FIG.12

130

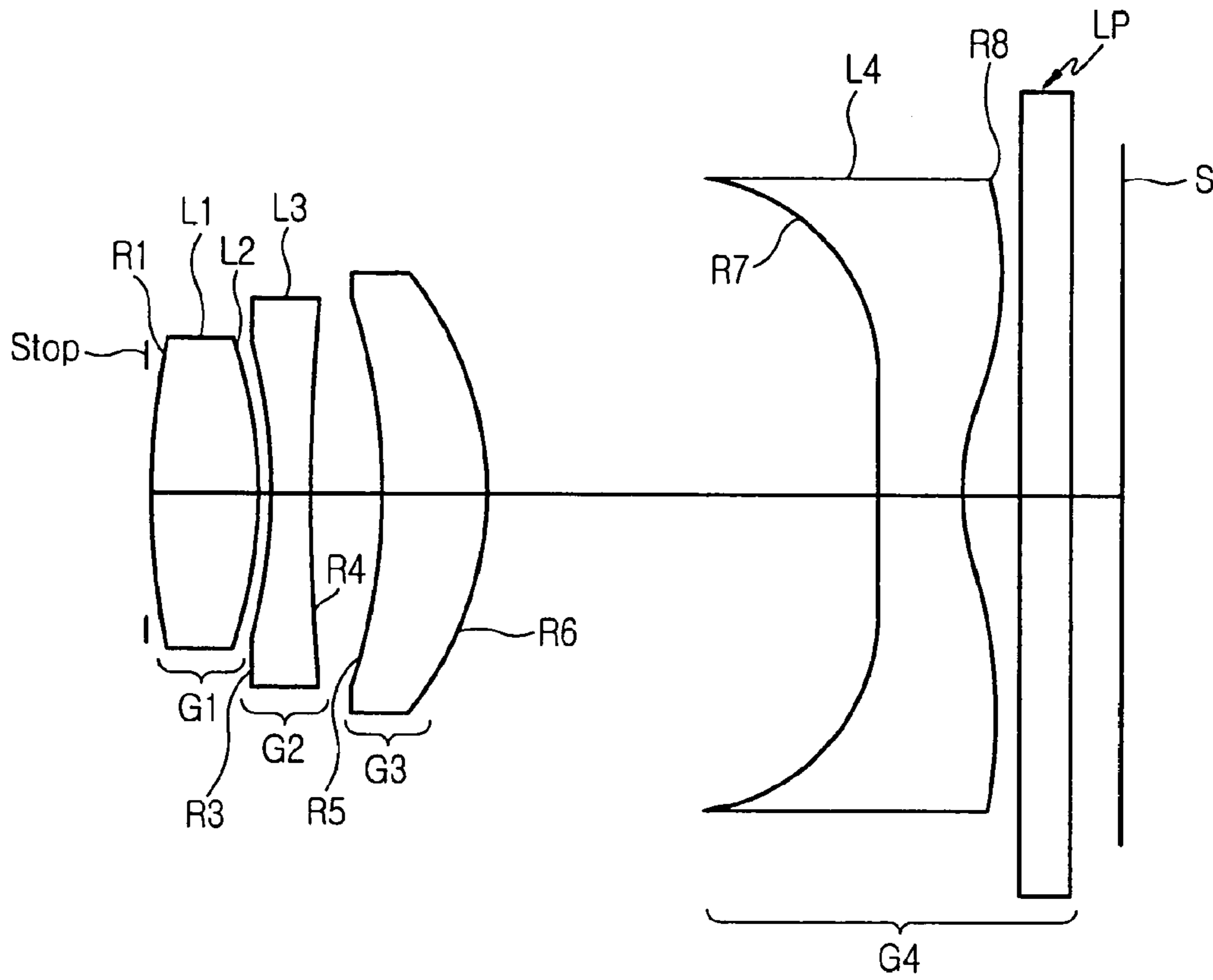

FIG.13

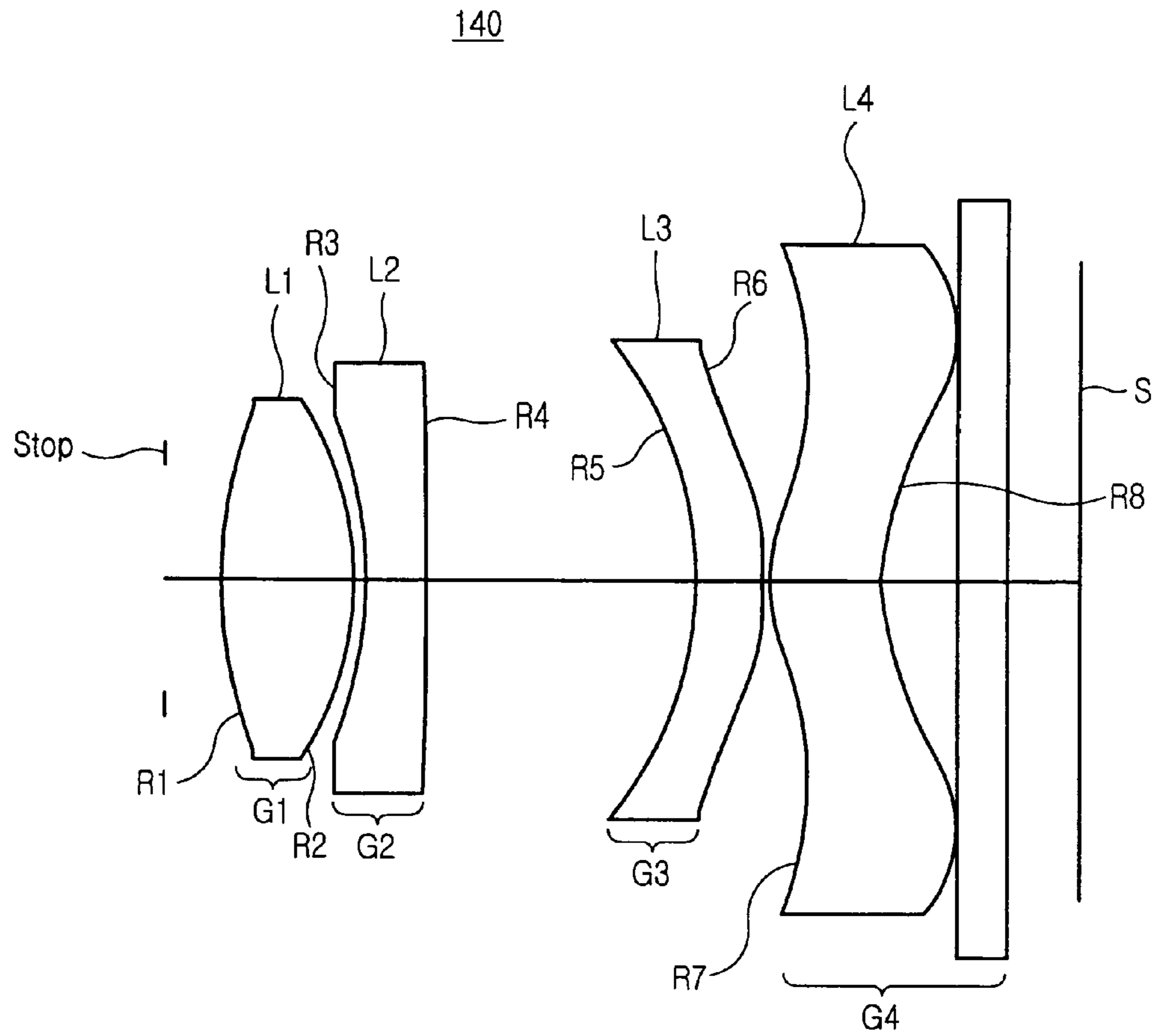

FIG.14

OPTICAL IMAGING SYSTEM

Matter enclosed in heavy brackets [] appears in the original patent but forms no part of this reissue specification; matter printed in italics indicates the additions made by reissue; a claim printed with strikethrough indicates that the claim was canceled, disclaimed, or held invalid by a prior post-patent action or proceeding.

[CLAIM OF PRIORITY] CROSS-REFERENCE TO RELATED APPLICATIONS

Notice: More than one reissue application has been filed for the reissue of U.S. Pat. No. 7,466,497. The reissue applications are application Ser. No. 12/970,720 (a reissue application of U.S. Pat. No. 7,466,497, reissued as U.S. Pat. No. Re. 44,773), Ser. No. 14/153,566 (this application, a divisional reissue of Ser. No. 12/970,720), and Ser. No. 14/153,710 (a continuation reissue of Ser. No. 12/970,720), all of which are reissues of U.S. Pat. No. 7,466,497.

This application is a divisional reissue application of U.S. patent application Ser. No. 12/970,720, filed Dec. 16, 2010, which is an application for reissue of U.S. Pat. No. 7,466,497, the contents of which are incorporated herein by reference.

This application claims priority to an application entitled "Optical Imaging System," filed with the Korean Intellectual Property Office on Jul. 7, 2005 and assigned Serial No. 2005-61174, the contents of which are incorporated herein by reference.

BACKGROUND [OF THE INVENTION]

1. Field of the Invention

The present invention generally relates to an optical system, and more particularly to an optical system including multiple lens groups having a reduced volume.

2. Description of the Related Art

An optical imaging system includes imaging elements such as CCD imaging elements (charged coupled devices) or CMOS imaging elements (complimentary metal oxide semiconductors) and at least one lens group for use in various types of consumer products such as digital and monitoring cameras, personal computers, and the like.

The lens group typically includes at least one lens having undesirable aberration characteristics. These undesirable aberration characteristics are intrinsic to the lens and are generated due to the shape of the lens. The aberration characteristics can cause distortion of images in certain circumstances. Among the different type of aberrations, the spherical and coma aberrations, in particular, cannot be easily corrected and can cause image flares and other undesirable visual effects.

In order to solve problems caused by such lens aberrations, it has been previously proposed in the prior art to utilize a lens group including an aspheric lens for correcting the aberrations, or a thin film filter or an optical filter having a sharp surface which can restrict a portion of the light.

Further, recent developments in image devices for miniaturization and portability, for use in miniaturized optical imaging systems require mounting in the image devices.

Therefore, it would be desirable to have an improved optical imaging system that is miniaturized and whose optical characteristics exhibit minimal deterioration over time.

SUMMARY [OF THE INVENTION]

Accordingly, the present invention has been made in view of the above-mentioned problems involved with the related art by providing an optical imaging system having a reduced volume and whose optical characteristics exhibit minimal deterioration over time.

One aspect of the present invention is to provide an optical imaging system including: a first lens group having a positive refractive power; a second lens group having a negative refractive power; a third lens group having a positive or negative power; and a fourth lens group having a positive or negative power.

BRIEF DESCRIPTION OF THE DRAWINGS

FIGS. 1 to 14 are views illustrating optical imaging systems according to particular embodiments of the present invention.

DETAILED DESCRIPTION

Hereinafter, embodiments of the present invention will be described with reference to the accompanying drawings. In the following description of the present invention, a detailed description of known functions and configurations incorporated herein is omitted to avoid making the subject matter of the present invention unclear.

FIG. 1 is a view for illustrating an optical system according to one embodiment of the present invention. Referring to FIG. 1, an optical imaging system 10, according to the present embodiment includes an image sensor S capable of photoelectric conversion, a first lens group G1, closest to a subject and having a positive refractive power, a second lens group G2 having a negative refractive power, a third lens group G3 having a positive or negative refractive power, and a fourth lens group G4 having a positive or negative refractive power. The image sensor S is preferably embodied as a CCD or a CMOS imaging element, or the like.

Each of the first to fourth lens groups G1 to G4 can include an aspheric lens on at least one surface thereof. The fourth lens group G4 is located adjacently to the image sensor S, and a parallel flat glass LP can be disposed between the fourth lens group G4 and the image sensor S. The parallel flat glass LP is a thin film filter or an optical filter, and can function as an infrared absorption filter and the like.

The following formulas (1) to (5) illustrate the relationship between the [focus distances] focal lengths of the various lens groups G1 to G4 and the [focus distance] focal length of the optical imaging system 10.

The first lens group G1 includes at least one lens of a positive refractive power, and the optical imaging system 10 satisfies formula (1).

$$0.3 < \frac{f_1}{f} < 3.1 \quad (1)$$

In formula (1), f denotes the [synthetic focus distance] total focal length of the optical imaging system and f_1 denotes the [focus distance] focal length of the first lens group.

The second lens group G2 includes at least one lens of a negative refractive power, and its [focus distance] focal length satisfies formula (2).

TABLE 1-continued

	Embodiment 1		Embodiment 2		Embodiment 3		Embodiment 4		Embodiment 5	
	Curvature Radius ([c] r)	Distance	Curvature Radius ([c] r)	Distance	Curvature Radius ([c] r)	Distance	Curvature Radius ([c] r)	Distance	Curvature Radius ([c] r)	Distance
[Aperture] Stop	∞	0.097	∞	0.158	∞	0.118	∞	0.030	∞	0.0594
2; R1	2.308	1.17	1.90143	1.174	3.27233	1.100	2.31076	1.066	2.9744	1.500
3; R2	-6.369	0.14	-1.20746	0.050	4.67332	0.103	-7.4386	0.10	-8.7847	0.4669
4; R3	-396.532	0.5357	-1.74939	0.363658	3.28408	0.671321	13.09940	0.300	19.62274	0.6000
5; R4	3.85393	0.8800640	4.33678	0.626369	2.76273	0.32772	3.44803	0.74667	3.68254	1.020392
6; R5	-2.81024	0.801423	-2.16510	1.200	-9.54821	0.900	-2.37523	0.797763	49.3243	1.500
7; R6	-1.30844	0.108171	-1.54462	0.959357	-1.66438	0.035965	-1.17766	0.061159	-0.6061	0.3000
8; R7	2.78412	0.798390	22.78452	0.643246	2.38024	0.750438	2.7701	0.813576	-0.9404	0.8410
9; R8	1.10058	0.6	2.80755	0.300	1.31748	1.200	1.10025	0.420	1.3115	0.5333
10 th surface	∞	0.3	∞	0.300	∞	0.345836	∞	0.300	∞	0.400
11 th surface	∞	0.594705	∞	0.78896	∞	1.808969	∞	0.729	∞	0.552
[Upper] Image surface	∞	-0.004867	∞	0.060517	∞	-0.024762	∞	-0.001979	∞	-0.0229

TABLE 2

	Embodiment 6		Embodiment 7		Embodiment 8		Embodiment 9		Embodiment 10	
	Curvature Radius ([c] r)	Distance	Curvature Radius ([c] r)	Distance	Curvature Radius ([c] r)	Distance	Curvature Radius ([c] r)	Distance	Curvature Radius ([c] r)	Distance
[Subject] Object	∞	∞	∞	∞	∞	∞	∞	∞	∞	∞
[Aperture] Stop	∞	0.6476	∞	0.3463	∞	0.4555	∞	0.030	∞	0.112
2 nd surface	3.13902	1.4131	2.66332	1.5000	3.25081	0.8732	2.68778	1.151	2.32028	1.0409
3 rd surface	-3.0951	0.1000	-3.9930	0.1323	-3.4043	0.1458	-6.9943	0.100	-6.2290	0.000
4 th surface	-3.2023	0.3000	-5.3522	0.6000	-2.6909	0.3000	-12.169	0.339	-40.0905	0.600
5 th surface	-17.430	2.1265	8.06170	1.0825	17.0230	0.1621	8.28938	2.268	4.30201	0.758760
6 th surface	-2.5800	0.8000	-1.9343	0.8000	-13.170	1.9366	-3.1380	0.958	-2.3804	0.800
7 th surface	-2.9025	0.0300	-1.6944	0.0300	-1.0714	0.0300	-2.2201	0.571	-1.18271	0.050
8 th surface	1.6766	1.0510	1.43882	0.8278	2.07137	0.5406	-46.094	0.439512	2.97821	0.759082
9 th surface	1.280758	0.6575	1.13450	0.5683	1.00140	0.7500	3.15688	0.635425	1.14396	0.60000
10 th surface	∞	0.3999	∞	0.3384	∞	0.3999	∞	0.400	∞	0.300
11 th surface	∞	0.5012	∞	1.0033	∞	0.3940	∞	1.087873	∞	1.15
[Upper] Image surface	∞	-0.001	∞	-0.0033	∞	0.0115	∞	-0.0026	∞	-0.001717

TABLE 3

	Embodiment 11		Embodiment 12		Embodiment 13		Embodiment 14	
	Curvature radius ([c] r)	Distance	Curvature radius ([c] r)	Distance	Curvature radius ([c] r)	Distance	Curvature radius ([c] r)	Distance
[Subject] Object	∞	∞	∞	∞	∞	∞	∞	∞
[Aperture] Stop	∞	0.122343	∞	0.172863	∞	0.0300	∞	0.480264

TABLE 3-continued

	Embodiment 11		Embodiment 12		Embodiment 13		Embodiment 14	
	Curvature radius ([c] r)	Distance	Curvature radius ([c] r)	Distance	Curvature radius ([c] r)	Distance	Curvature radius ([c] r)	Distance
2 nd surface	3.87998	0.490300	2.31854	1.219838	4.41591	0.81255	3.01153	1.10000
3 rd surface	-20.7340	2.001108	-6.32101	0.159417	-5.0714	0.1000	-3.45345	0.10000
4 th surface	7.75795	0.300000	-302.670	0.427352	-4.568	0.3000	-3.57593	0.50000
5 th surface	3.60180	0.672147	3.93461	0.742239	17.81786	0.55615	-25.0277	2.23581
6 th surface	-5.48009	1.123412	-2.26332	0.80000	-10.2402	0.8000	-2.62654	0.54408
7 th surface	-1.75190	0.03000	-1.16737	0.000	-3.2556	2.9643	-2.8477	0.08336
8 th surface	4.24622	1.243467	2.65978	0.796021	6.79551	0.7000	1.58235	0.88966
9 th surface	1.69995	0.53333	1.10575	0.70000	2.49781	0.4000	1.22608	0.63848
10 th surface	∞	0.399997	∞	0.3000	∞	0.4000	∞	0.39999
11 th surface	∞	0.85132	∞	0.69052	∞	0.3855	∞	0.60000
[Upper] Image surface	∞	-0.0126	∞	0.005756	∞	-0.0054	∞	-0.00001

Embodiment 1

The aspheric surfaces of the lenses constituting the optical imaging system according to the first embodiment are as presented in Table 4. The spherical surfaces and other conditions are as indicated in Table 1. The aspheric surfaces can be determined according to formula (9). The optical imaging system 10 according to the first embodiment includes a first lens group G1 having a positive refractive power, a second lens group G2 having a negative refractive power, a third lens group G3 having a positive or negative refractive power, a fourth lens group G4 having a positive or negative refractive power, a stop, and a thin film filter or an optical filter.

The stop is located on the incidence side of the optical imaging system 10, and the [introduced] incident light is output to the first lens group G1. The stop is used to regulate

20 The third lens group G3 includes a third lens L3. Both surfaces R5 and R6 of the third lens L3 are aspheric. The third lens L3 is separated from the second lens L2 by 0.088064 mm, and has a thickness of 0.801423 mm. The third lens L3 is formed of a material having a refractive index of 1.52996 and a [distribution value] dispersion constant of 55.8.

25 The fourth lens group G4 includes a fourth lens L4. Both surfaces R7 and R8 of the fourth lens L4 are aspheric. The fourth lens L4 is formed of a material having a refractive index of 1.52996 and a [distribution value] dispersion constant of 55.8. The thin film filter or the optical filter LP is formed on one surface of a BSC7-HOYA substrate by optical thin film deposition, and outputs partially restricted light through the fourth lens L4. The thin film filter or the optical filter LP is separated from the fourth lens L4 by 0.6 mm, and the thickness thereof is 0.3 mm.

TABLE 4

	K	A	B	C	D	E
2(R1)	-0.293462	-0.500119E-02	0.174440E-01	-0.454965E-01	0.46924E-01	-0.195854E-01
3(R2)	-9.260888	-0.800894E-02	-0.853100E-02	-0.490518E-02	-0.122591E-02	0.122831E-03
4(R3)	106224.0635	-0.120921E-01	-0.705929E-02	-0.207145E-02	-0.161995E-03	-0.210957E-03
5(R4)	0.365689	0.749905E-03	0.131150E-02	0.778014E-04	-0.121719E-03	0.572661E-03
6(R5)	-24.431171	-0.672890E-01	0.18948E-01	0.961734E-02	-0.435003E-02	0.806518E-03
7(R6)	-2.571360	-0.335648E-01	-0.109854E-01	0.181423E-01	-0.489429E-02	0.747733E-03
8(R7)	-17.862211	-0.795409E-01	0.310568E-01	-0.553846E-02	0.730076E-04	0.544935E-04
9(R8)	-4.629831	-0.533642E-01	0.17364E-01	-0.392400E-02	0.440467E-03	-0.212501E-04

the amount of the light introduced into the optical imaging system 10, and is separated from the first lens group G1 by 0.097005 mm.

The first lens group G1 includes a first lens L1 which outputs the light [introduced] incident through the stop to the second lens group G2. The first lens L1 includes second and third surfaces R1 and R2 which are aspheric, formed of a material having a refractive index of 1.529960 and a [distribution value] dispersion constant of 55.8. The thickness of the first lens L1 is 1.170132 mm. Note that the first surface designates the [irisi] stop.

The second lens group G2 includes a second lens L2 having a refractive index of 1.7552 and a [distribution value] dispersion constant of 27.53. The second lens L2 has fourth and fifth surfaces R3 and R4 which are aspheric. Referring to Table 1, the second lens group G2 is separated from the first lens L1 by 0.14 mm, and the center of the curvature is located on the optical axis.

Embodiment 2

50 The optical imaging system 20 according to the second embodiment includes a first lens group G1 having a positive refractive power, a second lens group G2 having a negative refractive power, a third lens group G3 having a positive or negative refractive power, a fourth lens group G4 having a positive or negative refractive power, a stop, and a thin film filter or an optical filter (LP).

60 The first lens group G1 includes a first lens L1, both surfaces R1 and R2 of which are aspheric. The thickness of the first lens L1 is 1.174399 mm. The first lens L1 is separated from the stop by 0.158423 mm.

65 The second lens group G2 includes a second lens L2 having a refractive index of 1.7552 and a [distribution value] dispersion constant of 27.53, and the second lens L2 has fourth and fifth surfaces R3 and R4 which are aspheric.

Referring to Table 1, the second lens L2 is separated from the first lens L1 by 0.05 mm, and has a thickness of 0.363658 mm.

The third lens group G3 includes a third lens L3. Both surfaces R5 and R6 of the third lens L3 are aspheric. The third lens L3 is separated from the second lens L2 by 0.626369 mm, and has a thickness of 1.200 mm. The third lens L3 is formed of a material having a refractive index of 1.52996 and a [distribution value] dispersion constant of 55.8.

The fourth lens group G4 includes a fourth lens L4. Both surfaces R7 and R8 of the fourth lens L4 are aspheric. The fourth lens L4 is formed of a material having a refractive index of 1.52996 and a [distribution value] dispersion constant of 55.8. The thin film filter or the optical filter LP is formed on one surface of a BSC7-HOYA substrate by optical thin film deposition, and outputs partially restricted light through the fourth lens L4.

The thin film filter or the optical filter LP is separated from the fourth lens L4 by 0.3 mm.

The aspheric specifications of the first to fourth lenses according to the second embodiment can be calculated as shown in Table 5 according to formula (9).

TABLE 5

	K	A	B	C	D	E
2(R1)	-0.257713	-0.515708E-02	0.209747E-01	-0.505970E-01	0.447308E-01	-0.188477E-01
3(R2)	-18.708087	-0.1032054E-01	-0.105518E-01	-0.865314E-02	-0.272928E-02	0.123342E-03
4(R3)	-43.346401	-0.181606E-01	-0.384568E-02	0.397337E-03	-0.676785E-03	-0.185398E-02
5(R4)	-0.927369	-0.184534E-02	0.328550E-01	0.145702E-01	-0.330705E-02	0.451156E-03
6(R5)	1.000662	-0.114554E+00	0.213009E-01	0.28671E-01	0.193745E-02	-0.723361E-02
7(R6)	-1.421093	-0.372122E-01	-0.953273E-02	0.172586E-01	-0.507483E-02	0.456643E-03
8(R7)	-2680755.274	-0.776437E-01	0.326426E-01	-0.516378E-02	0.139662E-03	0.354080E-05
9(R8)	-8.098312	-0.608029E-01	0.173038E-01	-0.354982E-02	0.459123E-03	-0.308217E-04

Embodiment 3

The optical imaging system 30 according to the third embodiment includes a first lens group G1 having a positive refractive power, a second lens group G2 having a negative

dispersion constant of 27.53. The second lens L2 has fourth and fifth surfaces R3 and R4 which are aspheric. Referring to Table 1, the second lens L2 is separated from the first lens L1 by 0.103084 mm, and the thickness thereof is 0.671321 mm.

The third lens group G3 includes a third lens L3. Both surfaces R5 and R6 of the third lens L3 are aspheric. The third lens L3 is separated from the second lens L2 by 0.327722 mm, and has a thickness of 0.9 mm. The third lens L3 is formed of a material having a refractive index of 1.48749 and a [distribution value] dispersion constant of 70.4058.

The fourth lens group G4 includes a fourth lens L4. Both surfaces R7 and R8 of the fourth lens L4 are aspheric. The fourth lens L4 is formed of a material having a refractive index of 1.516799 and a [distribution value] dispersion constant of 56.3954. The thin film filter or the optical filter LP is formed on one surface of a BSC7-HOYA substrate by optical thin film deposition, and outputs partially restricted light through the fourth lens L4. The thin film filter or the

optical filter LP is separated from the fourth lens L4 by 1.2 mm.

The aspheric specifications of the first to fourth lenses according to the third embodiment can be calculated as shown in Table 6 according to formula (9).

TABLE 6

	K	A	B	C	D	E
2(R1)	-1.835982	-0.540163E-02	0.375499E-02	-0.142352E-01	0.131732E-01	-0.519886E-02
3(R2)	-41.048843	-0.229191E-02	-0.938832E-02	0.209185E-02	0.433396E-02	-0.111937E-02
4(R3)	-11.973390	-0.112168E-01	-0.268986E-02	-0.187660E-03	0.394245E-03	-0.289163E-03
5(R4)	-1.905279	-0.658295E-02	0.186594E-03	-0.748272E-03	-0.467662E-03	0.229792E-04
6(R5)	-276.330987	-0.708063E-2	0.914221E-02	0.288806E-02	-0.131006E-02	-0.158700E-03
7(R6)	-3.139053	-0.110843E-01	-0.336114E-02	0.786618E-02	-0.901802E-03	0.284397E-03
8(R7)	-1.570846	-0.495767E-01	0.157197E-01	-0.238177E-02	0.155217E-04	0.480583E-04
9(R8)	-3.484978	-0.155739E-01	0.599301E-01	-0.140844E-02	0.125464E-03	0.154242E-04

refractive power, a third lens group G3 having a positive or negative refractive power, a fourth lens group G4 having a positive or negative refractive power, a stop, and a thin film filter or an optical filter.

The first lens group G1 includes a first lens L1, both surfaces R1 and R2 of which are aspheric. Referring to Table 1, the thickness of the first lens L1 is 1.10000 mm. The first lens L1 is separated from the stop by [0.18539] 0.118 mm.

The second lens group G2 includes a second lens L2 having a refractive index of 1.7552 and a [distribution value]

Embodiment 4

The optical imaging system 40 according to the fourth embodiment includes a first lens group G1 having a positive refractive power, a second lens group G2 having a negative refractive power, a third lens group G3 having a positive or negative refractive power, a fourth lens group G4 having a positive or negative refractive power, a stop, and a thin film filter or an optical filter.

The first lens group G1 includes a first lens L1, both surfaces R1 and R2 of which are aspheric. Referring to Table

1, the thickness of the first lens L1 is [1.16687] 1.066 mm. The first lens L1 is separated from the stop by 0.03 mm. The first lens L1 is formed of a material having a refractive index of 1.531449 and a [distribution value] dispersion constant of 66.1381.

The second lens group G2 includes a second lens L2 having a refractive index of 1.671174 and a [distribution value] dispersion constant of 32.0197. The fourth and fifth surfaces R3 and R4 of the second lens L2 are spherical. Referring to Table 1, the second lens L2 is separated from the first lens L1 by 0.102841 mm, and the thickness thereof is 0.3 mm.

The third lens group G3 includes a third lens L3. Both surfaces R5 and R6 of the third lens L3 are aspheric. The third lens L3 is separated from the second lens L2 by 0.746673 mm, and has a thickness of [0.9] 0.797763 mm. The third lens L3 is formed of a material having a refractive index of 1.532928 and a [distribution value] dispersion constant of 66.015.

The fourth lens group G4 includes a fourth lens L4. Eighth and ninth surfaces R7 and R8 of the fourth lens L4 are aspheric. The fourth lens L4 is formed of a material having a refractive index of 1.545534 and a [distribution value] dispersion constant of 65.0098. The thin film filter or the optical filter LP is formed on one surface of a BSC7-HOYA substrate by optical thin film deposition, and outputs partially restricted light through the fourth lens L4. The thin film filter or the optical filter LP is separated from the fourth lens L4 by 0.420622 mm.

The aspheric specifications of the first, third, and fourth lenses according to the fourth embodiment can be calculated as shown in Table 7 according to formula (9).

TABLE 7

	K	A	B	C	D	E
2(R1)	-0.414786	-0.681554E-02	0.202808E-01	-0.458051E-01	0.486110E-01	-0.192443E-01
3(R2)	-47.977483	0.753038E-03	-0.494574E-03	-0.938500E-03	-0.477371E-03	0.427775E-03
4(R3)						
5(R4)						
6(R5)	-15.896356	-0.668718E-1	0.195572E-01	0.949661E-02	-0.450552	0.799452E-03
7(R6)	-2.447435	-0.355564E-01	-0.106736E-01	0.187415E-01	-0.453123E-02	0.913004E-03
8(R7)	-13.319650	-0.816238E-01	0.306218E-01	-0.557765E-02	0.732077E-04	0.574664E-04
9(R8)	-4.692781	-0.568388E-01	0.179127E-01	-0.392127E-02	0.437571E-03	-0.21894E-04

Embodiment 5

The optical imaging system 50 according to the fifth embodiment includes a first lens group G1 having a positive refractive power, a second lens group G2 having a negative refractive power, a third lens group G3 having a positive or

negative refractive power, a fourth lens group G4 having a positive or negative refractive power, a stop, and a thin film filter or an optical filter.

The first lens group G1 includes a first lens L1 in which both surfaces R1 and R2 are aspheric. Referring to Table 1, the thickness of the first lens L1 is 1.5 mm. The first lens L1 is separated from the stop by 0.059478 mm. The first lens L1 is formed of a material having a refractive index of 1.533230 and a [distribution value] dispersion constant of 65.9899.

The second lens group G2 includes a second lens L2 having a refractive index of 1.755201 and a [distribution value] dispersion constant of 27.5795. The fourth and fifth surfaces R3 and R4 of the second lens L2 are spherical. Referring to Table 1, the second lens L2 is separated from the first lens L1 by 0.466939 mm, and the thickness thereof is 0.6 mm.

The third lens group G3 includes a third lens L3. The third lens L3 includes sixth and seventh surfaces R5 and R6 which are aspheric. The third lens L3 is separated from the second lens L2 by 1.020392 mm, and has a thickness of 1.5 mm. The third lens L3 is formed of a material having a refractive index of 1.526846 and a [distribution value] dispersion constant of 53.030473.

The fourth lens group G4 includes a fourth lens L4. The fourth lens L4 includes eighth and ninth surfaces R7 and R8 which are aspheric. The fourth lens L4 is formed of a material having a refractive index of 1.537416 and a [distribution value] dispersion constant of 50.1447. The thin film filter or the optical filter LP is formed on one surface of a BSC7-HOYA substrate by optical thin film deposition, and outputs partially restricted light through the fourth lens L4.

The thin film filter or the optical filter LP is separated from the fourth lens L4 by 0.533392mm.

The aspheric specifications of the first, third, and fourth lenses according to the fifth embodiment can be calculated as shown in Table 8 according to formula (9).

TABLE 8

	K	A	B	C	D	E
2(R1)	-0.394400	-0.272171E-02	0.416066E-02	-0.607051E-02	0.380128E-02	-0.863417E-03
3(R2)	-24.090048	-0.412473E-03	0.555552E-03	-0.275809E-03	-0.176666E-03	0.988739E-04
4(R3)						
5(R4)						
6(R5)	276.291590	-0.271502E-1	0.329418E-02	0.106440E-02	-0.323744E-03	0.428169E-04
7(R6)	-3.116597	-0.205921E-01	-0.130529E-02	0.278790E-02	-0.318606E-03	0.358108E-04
8(R7)	-6.168567	-0.189375E-01	0.732132E-02	-0.780195E-03	0.685421E-05	0.328986E-05
9(R8)	-15.211827	-0.200112E-01	0.342095E-02	-0.566744E-03	0.330318E-04	-0.670599E-06

13

Embodiment 6

The optical imaging system **60** according to the sixth embodiment includes a first lens group **G1** having a positive refractive power, a second lens group **G2** having a negative refractive power, a third lens group **G3** having a positive or negative refractive power, a fourth lens group **G4** having a positive or negative refractive power, a stop and a thin film filter or an optical filter.

The first lens group **G1** includes a first lens **L1** in which both surfaces **R1** and **R2** are aspheric. Referring to Table 2, the thickness of the first lens **L1** is 1.413171 mm. The first lens **L1** is separated from the stop by 0.647673 mm. The first lens **L1** is formed of a material having a refractive index of 1.529960 and a [distribution value] *dispersion constant* of 55.8.

The second lens group **G2** includes a second lens **L2** having a refractive index of 1.755201 and a [distribution value] *dispersion constant* of 27.5795. The fourth and fifth surfaces **R3** and **R4** of the second lens **L2** are spherical. Referring to Table 2, the second lens **L2** is separated from the first lens **L1** by 0.1 mm. The second lens **L2** has a thickness of [0.6] 0.3 mm.

The third lens group **G3** includes a third lens **L3**. The third lens **L3** includes sixth and seventh surfaces **R5** and **R6** which are aspheric. The third lens **L3** is separated from the second lens **L2** by 2.126507 mm, and has a thickness of 0.8 mm. The third lens **L3** is formed of a material having a refractive index of 1.675133 and a [distribution value] *dispersion constant* of 49.8062.

The fourth lens group **G4** includes a fourth lens **L4**. The fourth lens **L4** includes eighth and ninth surfaces **R7** and **R8** which are aspheric. The fourth lens **L4** is formed of a material having a refractive index of 1.52996 and a [distribution value] *dispersion constant* of 55.8. The thin film filter or the optical filter **LP** is formed on one surface of a BSC7-HOYA substrate by optical thin film deposition, and outputs the light passed through the fourth lens **L4**, with the light partially restricted. The thin film filter or the optical filter **LP** is separated from the fourth lens **L4** by 0.657592 mm.

The aspheric specifications of the first, third, and fourth lenses according to the sixth embodiment can be calculated as shown in Table 9 according to formula (9).

TABLE 9

	K	A	B	C	D	E
2(R1)	-0.519080	-0.306884E-02	0.210023E-02	-0.511064E-02	0.297608E-02	-0.933653E-03
3(R2)	-1.903494	-0.119853E-01	-0.166943E-02	-0.779414E-03	0.297154E-03	-0.211494E-03
4(R3)						
5(R4)						
6(R5)	-23.161960	-0.342151E-01	0.297570E-02	0.127086E-02	-0.331654E-03	-0.115883E-05
7(R6)	-2.184987	-0.101073E-01	-0.928938E-03	0.229837E-02	-0.435484E-03	0.286609E-04
8(R7)	-6.252505	-0.387574E-01	0.750058E-02	-0.666702E-03	0.344665E-05	0.497617E-06
9(R8)	-3.730467	-0.209098E-01	0.387332E-02	-0.561418E-03	0.327093E-04	-0.126355E-05

Embodiment 7

The optical imaging system **70** according to the seventh embodiment includes a first lens group **G1** having a positive

14

refractive power, a second lens group **G2** having a negative refractive power, a third lens group **G3** having a positive or negative refractive power, a fourth lens group **G4** having a positive or negative refractive power, a stop, and a thin film filter or an optical filter.

The first lens group **G1** includes a first lens **L1**. The second and third surfaces **R1** and **R2** of the first lens **L1** are aspheric. Referring to Table 2, the thickness of the first lens **L1** is 1.5 mm. The first lens **L1** is separated from the stop by 0.346363 mm. The first lens **L1** is formed of a material having a refractive index of 1.529960 and a [distribution value] *dispersion constant* of 55.8.

The second lens group **G2** includes a second lens **L2** having a refractive index of 1.755201 and a [distribution value] *dispersion constant* of 27.5795. The fourth and fifth surfaces **R3** and **R4** of the second lens **L2** are spherical. Referring to Table 2, the second lens **L2** is separated from the first lens **L1** by 0.132395 mm. The second lens has a thickness of 0.6 mm.

The third lens group **G3** includes a third lens **L3**. The third lens **L3** includes sixth and seventh surfaces **R5** and **R6** which are aspheric. The third lens **L3** is separated from the second lens **L2** by 1.082514 mm, and has a thickness of 0.8 mm. The third lens **L3** is formed of a material having a refractive index of 1.52996 and a [distribution value] *dispersion constant* of 55.8.

The fourth lens group **G4** includes a fourth lens **L4**. The fourth lens **L4** includes eighth and ninth surfaces **R7** and **R8** which are aspheric. The fourth lens **L4** is formed of a material having a refractive index of 1.581283 and a [distribution value] *dispersion constant* of 62.5343. The thin film filter or the optical filter **LP** is formed on one surface of a BSC7-HOYA substrate by optical thin film deposition, and outputs partially restricted light through the fourth lens **L4**. The thin film filter or the optical filter **LP** is separated from the fourth lens **L4** by 0.568307mm.

55

The aspheric specifications of the first, third, and fourth lenses according to the seventh preferred embodiment can be calculated as shown in Table 10 according to formula (9).

TABLE 10

	K	A	B	C	D	E
2(R1)	-0.225057	-0.331040E-02	0.124863E-01	-0.182585E-01	0.133184E-01	-0.345182E-02
3(R2)	-8.046311	-0.167705E-02	0.328944E-02	-0.511098E-03	-0.598276E-04	0.289249E-03
4(R3)						
5(R4)						

TABLE 10-continued

	K	A	B	C	D	E
6(R5)	-16.247560	-0.465774E-01	0.113697E-01	0.484777E-02	-0.139992E-02	0.124383E-03
7(R6)	-1.681469	-0.201264E-01	-0.355531E-02	0.780629E-02	-0.305484E-04	0.221913E-03
8(R7)	-3.679745	-0.597223E-01	0.166450E-01	-0.222994E-02	0.305484E-04	0.102808E-04
9(R8)	-3.208375	-0.436003E-01	0.103498E-01	-0.174130E-02	0.143919E-03	-0.563246E-05

Embodiment 8

The optical imaging system **80** according to the eighth embodiment includes a first lens group **G1** having a positive refractive power, a second lens group **G2** having a negative refractive power, a third lens group **G3** having a positive or negative refractive power, a fourth lens group **G4** having a positive or negative refractive power, a stop, and a thin film filter or an optical filter.

The first lens group **G1** includes a first lens **L1**. The second and third surfaces **R1** and **R2** of the first lens **L1** are aspheric. Referring to Table 2, the thickness of the first lens **L1** is 0.873219 mm. The first lens **L1** is separated from the stop by 0.455563 mm. The first lens **L1** is formed of a material having a refractive index of 1.618194 and a [distribution value] *dispersion constant* of 60.4374.

The second lens group **G2** includes a second lens **L2** having a refractive index of 1.755201 and a [distribution value] *dispersion constant* of 27.5795. The fourth and fifth surfaces **R3** and **R4** of the second lens **L2** are spherical. Referring to Table 2, the second lens **L2** is separated from the first lens **L1** by 0.145862 mm. The second lens has a thickness of 0.3 mm.

The third lens group **G3** includes a third lens **L3**. The third lens **L3** includes sixth and seventh surfaces **R5** and **R6** which are aspheric. The third lens **L3** is separated from the second lens **L2** by 0.162161 mm, and has a thickness of 1.936693 mm. The third lens **L3** is formed of a material having a refractive index of 1.62041 and a [distribution value] *dispersion constant* of 60.3236.

The fourth lens group **G4** includes a fourth lens **L4**. The fourth lens **L4** includes eighth and ninth surfaces **R7** and **R8** which are aspheric. The fourth lens **L4** is formed of a material having a refractive index of 1.755201 and a [distribution value] *dispersion constant* of 27.5795. The thin film filter or the optical filter **LP** is formed on one surface of a BSC7-HOYA substrate by optical thin film deposition, and outputs partially restricted light passed through the fourth lens **L4**. The thin film filter or the optical filter **LP** is separated from the fourth lens **L4** by 0.75533392 mm.

The aspheric specifications of the first, third, and fourth lenses according to the fifth embodiment can be calculated as shown in Table 11 according to formula (9).

TABLE 11

	K	A	B	C	D	E
2(R1)	-1.191537	-0.688942E-02	0.45124E-02	-0.510228E-02	0.398074E-02	-0.101575E-02
3(R2)	-18.472343	-0.122184E-01	-0.263919E-03	0.484905E-03	-0.122042E-03	-0.255869E-03
4(R3)						
5(R4)						
6(R5)	-131.77000	-0.157791E-01	0.64132E-02	0.126895E-02	-0.440931E-03	-0.131678E-04
7(R6)	-1.874970	-0.219439E-01	-0.444306E-02	0.215012E-02	-0.346726E-03	0.643482E-04
8(R7)	-2.843204	-0.606407E-01	0.869752E-02	0.885038E-04	0.256944E-04	-0.274999E-04
9(R8)	-2.494280	-0.463456E-01	0.597186E-02	-0.418213E-03	0.361972E-04	-0.371985E-05

10

Embodiment 9

The optical imaging system **90** according to the ninth embodiment includes a first lens group **G1** having a positive refractive power, a second lens group **G2** having a negative refractive power, a third lens group **G3** having a positive or negative refractive power, a fourth lens group **G4** having a positive or negative refractive power, a stop, and a thin film filter or an optical filter.

The first lens group **G1** includes a first lens **L1**. The second and third surfaces **R1** and **R2** are aspheric. Referring to Table 2, the thickness of the first lens **L1** is 1.151183 mm. The first lens **L1** is separated from the stop by 0.03 mm. The first lens **L1** is formed of a material having a refractive index of 1.544806 and a [distribution value] *dispersion constant* of 65.0658.

The second lens group **G2** includes a second lens **L2** having a refractive index of 1.730603 and a [distribution value] *dispersion constant* of 29.7565. The fourth and fifth surfaces **R3** and **R4** of the second lens **L2** are spherical. Referring to Table 2, the second lens **L2** is separated from the first lens **L1** by 0.1 mm. The second lens has a thickness of 0.359346 mm.

The third lens group **G3** includes a third lens **L3**. The third lens **L3** includes sixth and seventh surfaces **R5** and **R6** which are aspheric. The third lens **L3** is separated from the second lens **L2** by 2.268589 mm, and has a thickness of 0.958835 mm. The third lens **L3** is formed of a material having a refractive index of 1.581703 and a [distribution value] *dispersion constant* of 41.1859.

The fourth lens group **G4** includes a fourth lens **L4**. The fourth lens **L4** includes eighth and ninth surfaces **R7** and **R8** which are aspheric. The fourth lens **L4** is formed of a material having a refractive index of 1.590309 and a [distribution value] *dispersion constant* of 61.9836. The thin film filter or the optical filter **LP** is formed on one surface of a BSC7-HOYA substrate by optical thin film deposition, and outputs partially restricted light through the fourth lens **L4**. The thin film filter or the optical filter **LP** is separated from the fourth lens **L4** by 0.635425 mm.

The aspheric specifications of the first, third, and fourth lenses according to the ninth embodiment can be calculated as shown in Table 12 according to formula (9).

TABLE 12

	K	A	B	C	D	E
2(R1)	-0.430373	-0.390591E-02	0.392143E-02	-0.677606E-02	0.349668E-02	-0.844170E-03
3(R2)	-1.343031	-0.390591E-02	-0.221724E-02	-0.442053E-03	0.325453E-04	-0.124565E-03
4(R3)						
5(R4)						
6(R5)	-7.614910	-0.468815E-01	0.861470E-03	0.504936E-03	-0.657574E-03	0.716095E-04
7(R6)	-4.320744	-0.814544E-02	-0.177486E-02	0.246353E-02	-0.378555E-03	0.360668E-04
8(R7)	-3006.0608	-0.313430E-01	0.768252E-02	-0.638911E-03	0.198217E-04	0.177158E-06
9(R8)	-14.736676	-0.325749E-01	0.463409E-02	-0.543938E-03	0.288680E-03	0.146074E-06

Embodiment 10

The optical imaging system **100** according to the tenth embodiment includes a first lens group **G1** having a positive refractive power, a second lens group **G2** having a negative

The thin film filter or the optical filter **LP** is separated from the fourth lens **L4** by 0.6 mm.

The aspheric specifications of the first, third, and fourth lenses according to the tenth embodiment can be calculated as shown in Table 3 according to formula (9).

TABLE 13

	K	A	B	C	D	E
2(R1)	-0.243705	-0.472572E-02	0.208724E-01	-0.465959E-01	0.472830E-01	-0.179069E-01
3(R2)	-35.906408	-0.733648E-03	0.135638E-02	-0.206406E-03	-0.275201E-03	-0.584975E-04
4(R3)						
5(R4)						
6(R5)	-15.792759	-0.660694E-01	0.201054E-01	0.975285E-02	-0.440095E-02	0.84255E-03
7(R6)	-2.490058	-0.354334E-01	-0.109024E-01	0.185847E-01	-0.460071E-02	0.887947E-03
8(R7)	-17.989764	-0.827253E-01	0.309534E-01	-0.550268E-02	0.881897E-04	0.596575E-04
9(R8)	-5.078902	-0.565618E-01	0.183829E-01	-0.389874E-02	0.438295E-03	-0.216645E-04

refractive power, a third lens group **G3** having a positive or negative refractive power, a fourth lens group **G4** having a positive or negative refractive power, a stop, and a thin film filter or an optical filter.

The first lens group **G1** includes a first lens **L1**. The second and third surfaces **R1** and **R2** of the first lens are aspheric. Referring to Table 2, the thickness of the first lens **L1** is 1.040923 mm. The first lens **L1** is separated from the stop by 0.112233 mm. The first lens **L1** is formed of a material having a refractive index of 1.529960 and a [distribution value] *dispersion constant* of 55.8.

The second lens group **G2** includes a second lens **L2** having a refractive index of 1.75520 and a [distribution value] *dispersion constant* of 27.5305. The fourth and fifth surfaces **R3** and **R4** of the second lens **L2** are spherical. Referring to Table 2, the center portion of the second lens **L2** makes contact with the center of the first lens **L1**, and the thickness thereof is 0.6 mm.

The third lens group **G3** includes a third lens **L3**. The third lens **L3** includes sixth and seventh surfaces **R5** and **R6** which are aspheric. The third lens **L3** is separated from the second lens **L2** by 0.75876 mm, and has a thickness of 0.8 mm. The third lens **L3** is formed of a material having a refractive index of 1.529960 and a [distribution value] *dispersion constant* of 55.8.

The fourth lens group **G4** includes a fourth lens **L4**. The fourth lens **L4** includes eighth and ninth surfaces **R7** and **R8** which are aspheric. The fourth lens **L4** is formed of a material having a refractive index of 1.529960 and a [distribution value] *dispersion constant* of 55.8. The thin film filter or the optical filter **LP** is formed on one surface of a BSC7-HOYA substrate by optical thin film deposition, and outputs partially restricted light through the fourth lens **L4**.

Embodiment 11

The optical imaging system **50** according to the eleventh embodiment includes a first lens group **G1** having a positive refractive power, a second lens group **G2** having a negative refractive power, a third lens group **G3** having a positive or negative refractive power, a fourth lens group **G4** having a positive or negative refractive power, a stop, and a thin film filter or an optical filter.

The first lens group **G1** includes a first lens **L1**. The second and third surfaces **R1** and **R2** of the first lens **L1** are aspheric. Referring to Table 3, the thickness of the first lens **L1** is [1.4903] 0.4903 mm. The first lens **L1** is separated from the stop by 0.122343 mm. The first lens **L1** is formed of a material having a refractive index of 1.529960 and a [distribution value] *dispersion constant* of 55.8.

The second lens group **G2** includes a second lens **L2** having a refractive index of 1.75520 and a [distribution value] *dispersion constant* of 27.5305. The fourth and fifth surfaces **R3** and **R4** of the second lens **L2** are aspheric. Referring to Table 3, the second lens **L2** is separated from the first lens **L1** by 2.001108 mm. The second lens has a thickness of 0.3 mm.

The third lens group **G3** includes a third lens **L3**. The third lens **L3** includes sixth and seventh surfaces **R5** and **R6** which are aspheric. The third lens **L3** is separated from the second lens **L2** by 0.672147 mm, and has a thickness of 1.123412 mm. The third lens **L3** is formed of a material having a refractive index of 1.529960 and a [distribution value] *dispersion constant* of 55.8.

The fourth lens group **G4** includes a fourth lens **L4**. The fourth lens **L4** includes eighth and ninth surfaces **R7** and **R8** which are aspheric. The fourth lens **L4** is formed of a material having a refractive index of 1.529960 and a [distribution value] *dispersion constant* of 55.8. The thin film

filter or the optical filter LP is formed on one surface of a BSC7-HOYA substrate by optical thin film deposition, and outputs partially restricted light through the fourth lens L4. The thin film filter or the optical filter LP is separated from the fourth lens L4 by 0.53333 mm.

The aspheric specifications of the first, third, and fourth lenses according to the eleventh embodiment can be calculated as shown in Table 14 according to formula (9).

TABLE 14

	K	A	B	C	D	E
2(R1)	-0.325702	-0.246211E-02	0.388533E-02	-0.604015E-02	0.380199E-02	-0.943180E-03
3(R2)	-41.631817	0.494266E-05	0.263179E-03	-0.354857E-03	-0.299644E-03	0.164888E-03
4(R3)						
5(R4)						
6(R5)	42.685665	-0.286127E-01	0.464775E-02	0.147457E-02	-0.275325E-03	0.261278E-04
7(R6)	-2.322289	-0.142459E-01	-0.222570E-02	0.252860E-01	-0.342195E-03	0.386791E-04
8(R7)	-5.810899	-0.278816E-01	0.765382E-02	-0.752745E-03	0.209383E-05	0.216703E-05
9(R8)	-4.064375	-0.271353E-01	0.394463E-02	-0.533443E-03	0.332976E-04	-0.893693E-06

Embodiment 12

The optical imaging system 120 according to the twelfth embodiment includes a first lens group G1 having a positive refractive power, a second lens group G2 having a negative refractive power, a third lens group G3 having a positive or negative refractive power, a fourth lens group G4 having a positive or negative refractive power, a stop, and a thin film filter or an optical filter.

The fourth lens group G4 includes a fourth lens L4. The fourth lens L4 includes eighth and ninth surfaces R7 and R8 which are aspheric. The fourth lens L4 is formed of a material having a refractive index of 1.529960 and a [distribution value] dispersion constant of 55.8. The thin film filter or the optical filter LP is formed on one surface of a BSC7-HOYA substrate by optical thin film deposition, and

outputs partially restricted light through the fourth lens L4. The thin film filter or the optical filter LP is separated from the fourth lens L4 by 0.7 mm.

The aspheric specifications of the first, third, and fourth lenses according to the twelfth embodiment can be calculated as shown in Table 15 according to formula (9).

TABLE 15

	K	A	B	C	D	E
2(R1)	-0.293313	-0.542927E-02	0.212559E-01	-0.461572E-01	0.474595E-01	-0.180297E-01
3(R2)	-35.036564	0.831924E-03	0.133528E-02	0.317237E-03	0.719662E-05	0.460349E-05
4(R3)						
5(R4)						
6(R5)	-15.407195	-0.672666E-1	0.193978E-01	0.951188E-02	-0.442031E-02	0.886980E-03
7(R6)	-2.475560	-0.356856E-01	-0.108935E-01	0.186240E-01	-0.459365E-02	0.878806E-03
8(R7)	-14.369332	-0.818601E-01	0.304820E-01	-0.560236E-02	0.815708E-04	0.625730E-04
9(R8)	-5.062053	-0.596198E-01	0.176196E-01	-0.390136E-02	0.437454E-03	-0.222993E-04

The first lens group G1 includes a first lens L1. The second and third surfaces R1 and R2 of the first lens L1 are aspheric. Referring to Table 3, the thickness of the first lens L1 is 1.219838 mm. The first lens L1 is separated from the stop by 0.172863 mm. The first lens L1 is formed of a material having a refractive index of 1.532889 and a [distribution value] dispersion constant of 66.0182.

The second lens group G2 includes a second lens L2 having a refractive index of 1.75520 and a [distribution value] dispersion constant of 27.5795. The fourth and fifth surfaces R3 and R4 of the second lens L2 are spherical. Referring to Table 3, the second lens L2 is separated from the first lens L1 by [0.0.159417] 0.159417 mm. The second lens has a thickness of 0.427352 mm.

The third lens group G3 includes a third lens L3. The third lens L3 includes sixth and seventh surfaces R5 and R6 which are aspheric. The third lens L3 is separated from the second lens L2 by 0.742239 mm, and has a thickness of 0.8 mm. The third lens L3 is formed of a material having a refractive index of 1.5296 and a [distribution value] dispersion constant of 55.8.

Embodiment 13

The optical imaging system 130 according to the thirteenth embodiment includes a first lens group G1 having a positive refractive power, a second lens group G2 having a negative refractive power, a third lens group G3 having a positive or negative refractive power, a fourth lens group G4 having a positive or negative refractive power, a stop, and a thin film filter or an optical filter.

The first lens group G1 includes a first lens L1. The second and third surfaces R1 and R2 of the first lens L1 are aspheric. Referring to Table 1, the thickness of the first lens L1 is 0.812558 mm. The first lens L1 is separated from the stop by 0.03 mm. The first lens L1 is formed of a material having a refractive index of 1.602778 and a [distribution value] dispersion constant of 61.2648.

The second lens group G2 includes a second lens L2 having a refractive index of 1.742011 and a [distribution value] dispersion constant of 28.1334. The fourth and fifth surfaces R3 and R4 of the second lens L2 are spherical. Referring to Table 3, the second lens L2 is separated from the first lens L1 by 0.1 mm. The second lens L2 has a thickness of 0.3 mm.

The third lens group G3 includes a third lens L3. The third lens L3 includes sixth and seventh surfaces R5 and R6 which are aspheric. The third lens L3 is separated from the second lens L2 by 0.556157 mm, and has a thickness of 0.8 mm. The third lens L3 is formed of a material having a refractive index of 1.743972 and a [distribution value] dispersion constant of 44.8504.

The fourth lens group G4 includes a fourth lens L4. The fourth lens L4 includes eighth and ninth surfaces R7 and R8 which are aspheric. The fourth lens L4 is formed of a material having a refractive index of 1.719343 and a [distribution value] dispersion constant of 29.1913. The thin film filter or the optical filter LP is formed on one surface of a BSC7-HOYA substrate by optical thin film deposition, and outputs partially restricted light through the fourth lens L4. The thin film filter or the optical filter LP is separated from the fourth lens L4 by 0.4 mm.

The aspheric specifications of the first, third, and fourth lenses according to the thirteenth embodiment can be calculated as shown in Table 16 according to formula (9).

TABLE 16

	K	A	B	C	D	E
2(R1)	-3.105139	-0.765718E-02	-0.232543E-02	-0.548132E-02	0.355043E-02	-0.164865E-02
3(R2)	6.643484	-0.111248E-01	-0.189739E-02	-0.663328E-03	-0.291696E-03	0.148068E-04
4(R3)						
5(R4)						
6(R5)	-61.837170	-0.307620E-01	-0.299148E-03	0.881036E-04	-0.555307E-03	0.287414E-03
7(R6)	-1.252353	-0.165700E-01	-0.2082050E-02	0.832299E-03	-0.505810E-03	0.104507E-03
8(R7)	-4.091718	-0.559991E-01	0.354141E-02	-0.447725E-04	0.906043E-04	-0.235729E-04
9(R8)	-4.478957	-0.316105E-01	0.411904E-02	-0.364491E-03	0.274454E-04	-0.207865E-05

Embodiment 14

The optical imaging system 140 according to the fourteenth embodiment includes a first lens group G1 having a positive refractive power, a second lens group G2 having a negative refractive power, a third lens group G3 having a positive or negative refractive power, a fourth lens group G4 having a positive or negative refractive power, a stop, and a thin film filter or an optical filter.

Referring to Table 3, the second lens L2 is separated from the first lens L1 by 0.1 mm. The second lens has a thickness of [0.1] 0.5 mm.

The third lens group G3 includes a third lens L3. The third lens L3 includes sixth and seventh surfaces R5 and R6 which are aspheric. The third lens L3 is separated from the second lens L2 by 2.235814 mm, and has a thickness of [0.5] 0.54408 mm. The third lens L3 is formed of a material having a refractive index of 1.675133 and a [distribution value] dispersion constant of 40.8062.

The fourth lens group G4 includes a fourth lens L4. The fourth lens L4 includes eighth and ninth surfaces R7 and R8 which are aspheric. The fourth lens L4 is formed of a material having a refractive index of 1.529960 and a [distribution value] dispersion constant of 55.8. The thin film filter or the optical filter LP is formed on one surface of a BSC7-HOYA substrate by optical thin film deposition, and outputs partially restricted light through the fourth lens L4.

The thin film filter or the optical filter LP is separated from the fourth lens L4 by 0.63848 mm.

The aspheric specifications of the first, third, and fourth lenses according to the fourteenth embodiment can be calculated as shown in Table 17 according to formula (9).

TABLE 17

	K	A	B	C	D	E
2(R1)	-0.609678	-0.33651E-02	0.103994E-01	-0.531487E-02	0.265399E-02	-0.110303E-02
3(R2)	-2.046651	-0.118551E-01	-0.268572E-02	-0.121156E-02	0.310607E-03	-0.261769E-03
4(R3)	-0.023479	-0.621511E-05	0.506488E-03	0.302229E-03	0.613363E-04	0.105352E-03
5(R4)	-20.447531	0.207610E-03	0.4772207E-03	0.199399E-03	0.764266E-04	-0.296394E-04
6(R5)	-28.099749	-0.345382E-01	0.291077E-02	0.117431E-02	-0.344832E-03	0.114845E-05
7(R6)	-2.937952	-0.914876E-02	-0.914771E-03	0.232561E-02	-0.431406E-03	0.285117E-04
8(R7)	-7.164502	-0.397733E-01	0.765148E-02	-0.688572E-03	0.363819E-05	0.182078E-05
9(R8)	-3.704332	-0.236715E-01	0.386753E-02	-0.536289	0.341922E-04	-0.149054E-05

The first lens group G1 includes a first lens L1. The second and third surfaces R1 and R2 of the first lens L1 are aspheric. Referring to Table 3, the thickness of the first lens L1 is 1.1 mm. The first lens L1 is separated from the stop by 0.480264 mm. The first lens L1 is formed of a material having a refractive index of 1.529960 and a [distribution value] dispersion constant of 55.8.

The second lens group G2 includes a second lens L2 having a refractive index of 1.75520 and a [distribution value] dispersion constant of 27.5795. The fourth and fifth surfaces R3 and R4 of the second lens L2 are spherical.

In sum, the optical imaging system of the present invention reduces the volume and minimizes the deterioration of the optical characteristics, such as flares, with a high resolution.

While the invention has been shown and described with reference to certain preferred embodiments thereof, it will be understood by those skilled in the art that various changes in form and details may be made therein without departing from the spirit and scope of the invention as defined by the appended claims.

What is claimed is:

[1. An optical imaging system comprising an image sensor for photoelectric conversion, the optical imaging system further comprising:

a first lens group having a positive refractive power closest to a subject;

a second lens group closest to the first lens group and having a negative refractive power;

a third lens group having one of a positive or negative power; and

a fourth lens group having one of a positive or negative power,

wherein each of the first to fourth lens groups comprises an aspheric lens having at least one aspheric surface thereof; and

one of a thin film filter or an optical filter for restricting the transmission of a portion of light between the second and third lens groups or between the third and fourth lens groups.]

[2. An optical imaging system according to claim 1, wherein the first lens group comprises at least one lens of a positive refractive power.]

[3. An optical imaging system according to claim 1, wherein the second lens group comprises at least one lens of a negative refractive power.]

[4. An optical imaging system according to claim 1, wherein the third lens group comprises at least one lens of a positive or negative refractive power.]

[5. An optical imaging system according to claim 1, wherein a fourth lens group comprises at least one lens of a positive or negative refractive power.]

[6. An optical imaging system according to claim 1, wherein the optical imaging system satisfies

$$0.3 < \frac{f_1}{f} < 3.1,$$

wherein f denotes synthetic focus distance of the optical imaging system and f_1 denotes focus distance of the first lens group.]

[7. An optical imaging system according to claim 1, wherein the optical imaging system satisfies

$$0.3 < \frac{|f_2|}{f} < 8.99,$$

wherein f denotes a synthetic focus distance of the optical imaging system and f_2 denotes a focus distance of the second lens group.]

[8. An optical imaging system according to claim 1, wherein the optical imaging system satisfies

$$0.19 < \frac{f_3}{f} < \infty,$$

wherein f denotes a synthetic focus distance of the optical imaging system and f_3 denotes a focus distance of the third lens group.]

[9. An optical imaging system according to claim 1, wherein the optical imaging system satisfies

$$0.15 < \frac{|f_4|}{f} < \infty,$$

wherein f denotes a synthetic focus distance of the optical imaging system and f_4 denotes a focus distance of the second lens group.]

[10. An optical imaging system comprising an image sensor for photoelectric conversion, the optical imaging system further comprising:

a first lens group having a positive refractive power;

a second lens group having a negative refractive power;

a third lens group having one of a positive or negative power; and

a fourth lens group having one of a positive or negative power, wherein the optical imaging system satisfies

$$0.45 < \frac{f}{TTL} < 1.01,$$

wherein f denotes a synthetic focus distance of the optical imaging system and TTL denotes a distance from an iris surface to an imaging surface;

wherein a lens located in the first lens group and having at least one aspheric surface; and

one of a thin film filter or an optical filter for restricting the transmission of a portion of light between the second and third lens groups or between the third and fourth lens groups.]

[11. An optical imaging system according to claim 10, further comprising a parallel flat glass disposed between the image sensor and the fourth lens group.]

[12. An optical imaging system comprising an image sensor for photoelectric conversion, the optical imaging system further comprising:

a first lens group having a positive refractive power;

a second lens group having a negative refractive power;

a third lens group having one of a positive or negative power; and

a fourth lens group having one of a positive or negative power, wherein the first and second lens groups satisfy an optical axis direction size according to

$$0 < \frac{d_1}{TTL} < 0.26,$$

wherein d_1 denotes a separated distance between the first lens group and the second lens group on the optical axis and TTL denotes a distance from an iris surface to an imaging surface;

wherein a lens located in the first lens group and having at least one aspheric surface; and

one of a thin film filter or an optical filter for restricting the transmission of a portion of light between the second and third lens groups or between the third and fourth lens groups.]

[13. An optical imaging system according to claim 12, further comprising a parallel flat glass disposed between the image sensor and the fourth lens group.]

[14. An optical imaging system comprising an image sensor for photoelectric conversion, the optical imaging system further comprising:

a first lens group having a positive refractive power;

a second lens group having a negative refractive power;

25

- a third lens group having one of a positive or negative power; and
 a fourth lens group having one of a positive or negative power, wherein the third and fourth lens groups satisfy an optical axis direction size according to

$$0 < \frac{d_3}{TTL} < 0.40,$$

wherein d_3 denotes a separated distance between the third lens group and the fourth lens group on the optical axis and TTL denotes a distance from an iris surface to an imaging surface;
 wherein a lens located in the first lens group and having at least one aspheric surface; and

one of a thin film filter or an optical filter for restricting the transmission of a portion of light between the second and third lens groups or between the third and fourth lens groups.]

[15. An optical imaging system according to claim 14, further comprising a parallel flat glass disposed between the image sensor and the fourth lens group.]

[16. An optical imaging system comprising an image sensor for photoelectric conversion, the optical imaging system further comprising:

- a first lens group having a positive refractive power closest to a subject;
 a second lens group closest to the first lens group and having a negative refractive power;
 a third lens group having one of a positive or negative power; and
 a fourth lens group having one of a positive or negative power,

wherein each of the first to fourth lens groups comprises an aspheric lens having at least one aspheric surface thereof, and

wherein the Abbe's numbers of the first and second lens groups G1 and G2 satisfy

$$28.2 < v_1 - v_2 < 42.8,$$

wherein v_1 and v_2 denote Abbe's numbers representing the distribution characteristics of the first and second lens groups respectively.]

17. An optical imaging system comprising:
 a first lens group comprising a first lens with an object side surface having a positive curvature, and having a positive refractive power;

a second lens group comprising a second lens with an object side surface having a positive curvature and with an image side surface having a positive curvature, and having a negative refractive power;

a third lens with an object side surface having a negative curvature and with an image side surface having a negative curvature, and having one of a positive or negative refractive power; and

a fourth lens having a negative refractive power, wherein each of the first lens group, the second lens group, the third lens, and the fourth lens comprises an aspheric lens having at least one aspheric surface thereof,

wherein the optical imaging system satisfies the following equation:

$$28.2 < v_1 - v_2 < 42.8,$$

26

wherein v_1 and v_2 denote Abbe's numbers representing dispersion characteristics of the first lens group and the second lens group, respectively.

18. The optical imaging system of claim 17, wherein an object side surface and an image side surface of the fourth lens are aspheric.

19. The optical imaging system of claim 17, wherein the fourth lens is a lens with an object side surface having a positive curvature and with an image side surface having a positive curvature.

20. The optical imaging system of claim 19, wherein a sign of a curvature is changed when at least one of the object side surface and the image side surface of the fourth lens is distant from an optical axis.

21. The optical imaging system of claim 17, wherein the first lens comprises an image side surface having one of a negative or positive curvature.

22. The optical imaging system of claim 17, wherein the first lens and the second lens contact each other.

23. The optical imaging system of claim 17, wherein each of the first through fourth lenses comprises at least one aspheric surface.

24. The optical imaging system of claim 17, wherein the optical imaging system satisfies the following equation:

$$0.45 < \frac{f}{TTL} < 1.01,$$

wherein f denotes a total focal length of the optical imaging system and TTL denotes a distance from an iris surface to an imaging surface.

25. The optical imaging system of claim 17, wherein the optical imaging system satisfies the following equation:

$$0.3 < \frac{f_1}{f} < 3.1,$$

$$0.3 < \frac{|f_2|}{f} < 8.99,$$

wherein f denotes a total focal length of the optical imaging system, f_1 denotes a focal length of the first lens, and f_2 denotes a focal length of the second lens.

26. The optical imaging system of claim 17, wherein the optical imaging system satisfies the following equation:

$$0.19 < \frac{|f_3|}{f} < \infty,$$

$$0.15 < \frac{|f_4|}{f} < \infty,$$

wherein f denotes a total focal length of the optical imaging system, f_3 denotes a focal length of the third lens, and f_4 denotes a focal length of the fourth lens.

27. The optical imaging system of claim 17, wherein an iris is disposed at an object side of the first lens.

28. The optical imaging system of claim 17, wherein the optical imaging system satisfies the following equation:

$$0 < \frac{d_1}{TTL} < 0.26,$$

wherein d_1 denotes a separated distance between the first lens and the second lens on the optical axis and TTL denotes a distance from an iris surface to an imaging surface.

29. The optical imaging system of claim 17, wherein the optical imaging system satisfies the following equation:

$$0 < \frac{d_3}{TTL} < 0.40,$$

wherein d_3 denotes a separated distance between the third lens and the fourth lens on the optical axis and TTL denotes a distance from an iris surface to an imaging surface.

30. An optical imaging system comprising:

a first lens group comprising a first lens with an object side surface having a positive curvature, and having a positive refractive power;

a second lens group comprising a second lens with an object side surface having a positive curvature and with an image side surface having a positive curvature, and having a negative refractive power;

a third lens having one of a positive or negative refractive power; and

a fourth lens having a negative refractive power, and comprising at least one aspheric surface,

wherein each of the first lens group, the second lens group, the third lens, and the fourth lens comprises an aspheric lens having at least one aspheric surface thereof,

wherein the optical imaging system satisfies the following equation:

$$28.2 < \nu_1 - \nu_2 < 42.8,$$

wherein ν_1 and ν_2 denote Abbe's numbers representing dispersion characteristics of the first lens group and the second lens group, respectively.

31. The optical imaging system of claim 30, wherein the object side surface of the fourth lens has a positive curvature, and the image side surface of the fourth lens has a positive curvature.

32. The optical imaging system of claim 30, wherein a sign of a curvature is changed when at least one of the object side surface and the image side surface of the fourth lens is distant from an optical axis.

33. The optical imaging system of claim 30, wherein the first lens comprises an image side surface having one of a negative or positive curvature.

34. The optical imaging system of claim 30, wherein the first lens and the second lens contact each other.

35. The optical imaging system of claim 30, wherein each of the first through third lenses comprises at least one aspheric surface.

36. The optical imaging system of claim 30, wherein the optical imaging system satisfies the following equation:

$$0.45 < \frac{f}{TTL} < 1.01,$$

wherein f denotes a total focal length of the optical imaging system and TTL denotes a distance from an iris surface to an imaging surface.

37. The optical imaging system of claim 30, wherein the optical imaging system satisfies the following equation:

$$0.3 < \frac{f_1}{f} < 3.1,$$

$$0.3 < \frac{|f_2|}{f} < 8.99,$$

wherein f denotes a total focal length of the optical imaging system, f_1 denotes a focal length of the first lens, and f_2 denotes a focal length of the second lens.

38. The optical imaging system of claim 30, wherein the optical imaging system satisfies the following equation:

$$0.19 < \frac{|f_3|}{f} < \infty,$$

$$0.15 < \frac{|f_4|}{f} < \infty,$$

wherein f denotes a total focal length of the optical imaging system, f_3 denotes a focal length of the third lens, and f_4 denotes a focal length of the fourth lens.

39. The optical imaging system of claim 30, wherein an iris is disposed at an object side of the first lens.

40. The optical imaging system of claim 30, wherein the optical imaging system satisfies the following equation:

$$0 < \frac{d_1}{TTL} < 0.26,$$

wherein d_1 denotes a separated distance between the first lens and the second lens on the optical axis and TTL denotes a distance from an iris surface to an imaging surface.

41. The optical imaging system of claim 30, wherein the optical imaging system satisfies the following equation:

$$0 < \frac{d_3}{TTL} < 0.40,$$

wherein d_3 denotes a separated distance between the third lens and the fourth lens on the optical axis and TTL denotes a distance from an iris surface to an imaging surface.

42. The optical imaging system of claim 30, wherein the fourth lens comprises an aspheric object side surface and an aspheric image side surface.

43. An optical imaging system comprising:

a first lens group comprising a first lens having a positive refractive power;

a second lens group comprising a second lens with an object side surface having a positive curvature and with an image side surface having a positive curvature, and having a negative refractive power;

a third lens having one of a positive or negative refractive power; and

a fourth lens with an object side surface having a positive curvature and with an image side surface having a positive curvature, and having a negative refractive power,

wherein each of the first lens group, the second lens group, the third lens, and the fourth lens comprises an aspheric lens having at least one aspheric surface thereof,

29

wherein the optical imaging system satisfies the following equation:

$$28.2 < \nu_1 - \nu_2 < 42.8,$$

wherein ν_1 and ν_2 denote Abbe's numbers representing dispersion characteristics of the first lens group and the second lens group, respectively.

44. The optical imaging system of claim 43, wherein a sign of a curvature is changed when at least one of the object side surface and the image side surface of the fourth lens is distant from an optical axis.

45. The optical imaging system of claim 44, wherein the first lens comprises an object side surface having a positive curvature, and an image side surface having one of a negative or positive curvature.

46. The optical imaging system of claim 43, wherein the first lens and the second lens contact each other.

47. The optical imaging system of claim 43, wherein each of the first through fourth lenses comprises at least one aspheric surface.

48. The optical imaging system of claim 43, wherein the optical imaging system satisfies the following equation:

$$0.45 < \frac{f}{TTL} < 1.01,$$

wherein f denotes a total focal length of the optical imaging system and TTL denotes a distance from an iris surface to an imaging surface.

49. The optical imaging system of claim 43, wherein the optical imaging system satisfies the following equation:

$$0.3 < \frac{f_1}{f} < 3.1,$$

$$0.3 < \frac{|f_2|}{f} < 8.99,$$

wherein f denotes a total focal length of the optical imaging system, f_1 denotes a focal length of the first lens, and f_2 denotes a focal length of the second lens.

50. The optical imaging system of claim 43, wherein the optical imaging system satisfies the following equation:

$$0.19 < \frac{|f_3|}{f} < \infty,$$

$$0.15 < \frac{|f_4|}{f} < \infty,$$

wherein f denotes a total focal length of the optical imaging system, f_3 denotes a focal length of the third lens, and f_4 denotes a focal length of the fourth lens.

51. The optical imaging system of claim 43, wherein an iris is disposed at an object side of the first lens.

52. The optical imaging system of claim 43, wherein the optical imaging system satisfies the following equation:

$$0 < \frac{d_1}{TTL} < 0.26,$$

30

wherein d_1 denotes a separated distance between the first lens and the second lens on the optical axis and TTL denotes a distance from an iris surface to an imaging surface.

53. The optical imaging system of claim 43, wherein the optical imaging system satisfies the following equation:

$$0 < \frac{d_3}{TTL} < 0.40,$$

wherein d_3 denotes a separated distance between the third lens and the fourth lens on the optical axis and TTL denotes a distance from an iris surface to an imaging surface.

54. An optical imaging system comprising:
a first lens group comprising a first lens having a positive refractive power;

a second lens group comprising a second lens with an object side surface having a positive curvature and with an image side surface having a positive curvature, and having a negative refractive power;

a third lens having one of a positive or negative refractive power; and

a fourth lens having a negative refractive power, and comprising at least one aspheric surface,

wherein each of the first lens group, the second lens group, the third lens, and the fourth lens comprises an aspheric lens having at least one aspheric surface thereof,

wherein the optical imaging system satisfies the following equations:

$$0.3 < \frac{f_1}{f} < 3.1,$$

$$0.3 < \frac{|f_2|}{f} < 8.99,$$

wherein f denotes a total focal length of the optical imaging system, f_1 denotes a focal length of the first lens, and f_2 denotes a focal length of the second lens;

$$28.2 < \nu_1 - \nu_2 < 42.8,$$

wherein ν_1 and ν_2 denote Abbe's numbers representing dispersion characteristics of the first lens group and the second lens group, respectively.

55. The optical imaging system of claim 54, wherein the optical imaging system satisfies the following equation:

$$0.19 < \frac{|f_3|}{f} < \infty,$$

$$0.15 < \frac{|f_4|}{f} < \infty,$$

wherein f denotes a total focal length of the optical imaging system, f_3 denotes a focal length of the third lens, and f_4 denotes a focal length of the fourth lens.

56. The optical imaging system of claim 54, wherein the first lens comprises an object side surface having a positive curvature.

57. The optical imaging system of claim 54, wherein the fourth lens comprises an object side surface having a positive curvature, and an image side surface having a positive curvature.

31

58. The optical imaging system of claim 54, wherein the fourth lens comprises an aspheric object side surface and an aspheric image side surface.

59. An optical imaging system comprising:

a first lens group comprising a first lens having a positive refractive power;

a second lens group comprising a second lens with an object side surface having a positive curvature and with an image side surface having a positive curvature, and having a negative refractive power;

a third lens having one of a positive or negative refractive power; and

a fourth lens having a negative refractive power, and comprising at least one aspheric surface,

wherein the optical imaging system satisfies the following equation:

$$0.45 < \frac{f}{TTL} < 1.01,$$

wherein f denotes a total focal length of the optical imaging system and TTL denotes a distance from an iris surface to an imaging surface;

$$0 < \frac{d_1}{TTL} < 0.26,$$

wherein d_1 denotes a separated distance between the first lens and the second lens on the optical axis and TTL denotes a distance from an iris surface to an imaging surface;

$$0 < \frac{d_3}{TTL} < 0.40,$$

32

wherein d_3 denotes a separated distance between the third lens and the fourth lens on the optical axis and TTL denotes a distance from an iris surface to an imaging surface;

$$0.3 < \frac{f_1}{f} < 3.1,$$

$$0.3 < \frac{|f_2|}{f} < 8.99,$$

wherein f denotes a total focal length of the optical imaging system, f_1 denotes a focal length of the first lens, and f_2 denotes a focal length of the second lens; wherein each of the first lens group, the second lens group, the third lens, and the fourth lens comprises an aspheric lens having at least one aspheric surface thereof;

wherein the optical imaging system satisfies the following equation:

$$28.2 < \nu_1 - \nu_2 < 42.8,$$

wherein ν_1 and ν_2 denote Abbe's numbers representing dispersion characteristics of the first lens group and the second lens group, respectively.

60. The optical imaging system of claim 59, wherein the first lens comprises an object side surface having a positive curvature.

61. The optical imaging system of claim 59, wherein the object side surface of the fourth lens has a positive curvature, and the image side surface of the fourth lens has a positive curvature.

62. The optical imaging system of claim 59, wherein a sign of a curvature is changed when at least one of the object side surface and the image side surface of the fourth lens is distant from an optical axis.

63. The optical imaging system of claim 59, wherein the fourth lens comprises an aspheric object side surface and an aspheric image side surface.

* * * * *