



US00RE46233E

(19) **United States**
(12) **Reissued Patent**
Zhang et al.

(10) **Patent Number: US RE46,233 E**
(45) **Date of Reissued Patent: Dec. 6, 2016**

(54) **METHOD AND APPARATUS FOR SCHEDULING TRANSMISSIONS VIA AN ENHANCED DEDICATED CHANNEL**

USPC 370/318, 338
See application file for complete search history.

(71) Applicant: **InterDigital Technology Corporation**,
Wilmington, DE (US)

(72) Inventors: **Guodong Zhang**, Syosset, NY (US);
Kyle Jung-Lin Pan, Saint James, NY (US); **Peter S. Wang**, E. Setauket, NY (US); **Robert A. DiFazio**, Greenlawn, NY (US); **Stephen E. Terry**, Northport, NY (US)

(73) Assignee: **InterDigital Technology Corporation**,
Wilmington, DE (US)

(21) Appl. No.: **14/135,739**

(22) Filed: **Dec. 20, 2013**

Related U.S. Patent Documents

Reissue of:

(64) Patent No.: **8,081,595**
Issued: **Dec. 20, 2011**
Appl. No.: **12/173,363**
Filed: **Jul. 15, 2008**

U.S. Applications:

(63) Continuation of application No. 11/402,718, filed on Apr. 12, 2006, now Pat. No. 7,408,895.

(60) Provisional application No. 60/673,076, filed on Apr. 20, 2005.

(51) **Int. Cl.**
H04W 52/34 (2009.01)

(52) **U.S. Cl.**
CPC **H04W 52/346** (2013.01)

(58) **Field of Classification Search**
CPC H04B 7/185; H04W 52/346

(56) **References Cited**

U.S. PATENT DOCUMENTS

6,654,358 B1 11/2003 Park et al.
6,845,088 B2 1/2005 Terry et al.
7,010,317 B2 * 3/2006 Hwang et al. 455/522
7,058,032 B2 * 6/2006 Iacono et al. 370/329

(Continued)

OTHER PUBLICATIONS

Interdigital, "Text Proposal on Enhanced Uplink MAC Architecture for TS 25.309," 3GPP TSG RAN WG2, #43, R2-041439, Prague, Czech Republic (Aug. 16-20, 2004).

(Continued)

Primary Examiner — Mary Steelman

(74) *Attorney, Agent, or Firm* — Volpe and Koenig, P.C.

(57) **ABSTRACT**

A method and apparatus for scheduling transmissions via an enhanced dedicated channel (E-DCH) are disclosed. A scheduled power is calculated for scheduled data flows. A remaining transmit power is calculated for the E-DCH transmission. A rate request message is generated, wherein the scheduled power, remaining transmit power and rate request message are used to select transport format combinations (TFCs) and multiplex data scheduled for the E-DCH transmission. The remaining transmit power is calculated by subtracting from a maximum allowed power the power of a dedicated physical data channel (DPDCH), a dedicated physical control channel (DPCCCH), a high speed dedicated physical control channel (HS-DPCCH), an enhanced uplink dedicated physical control channel (E-DPCCH) and a power margin.

41 Claims, 5 Drawing Sheets

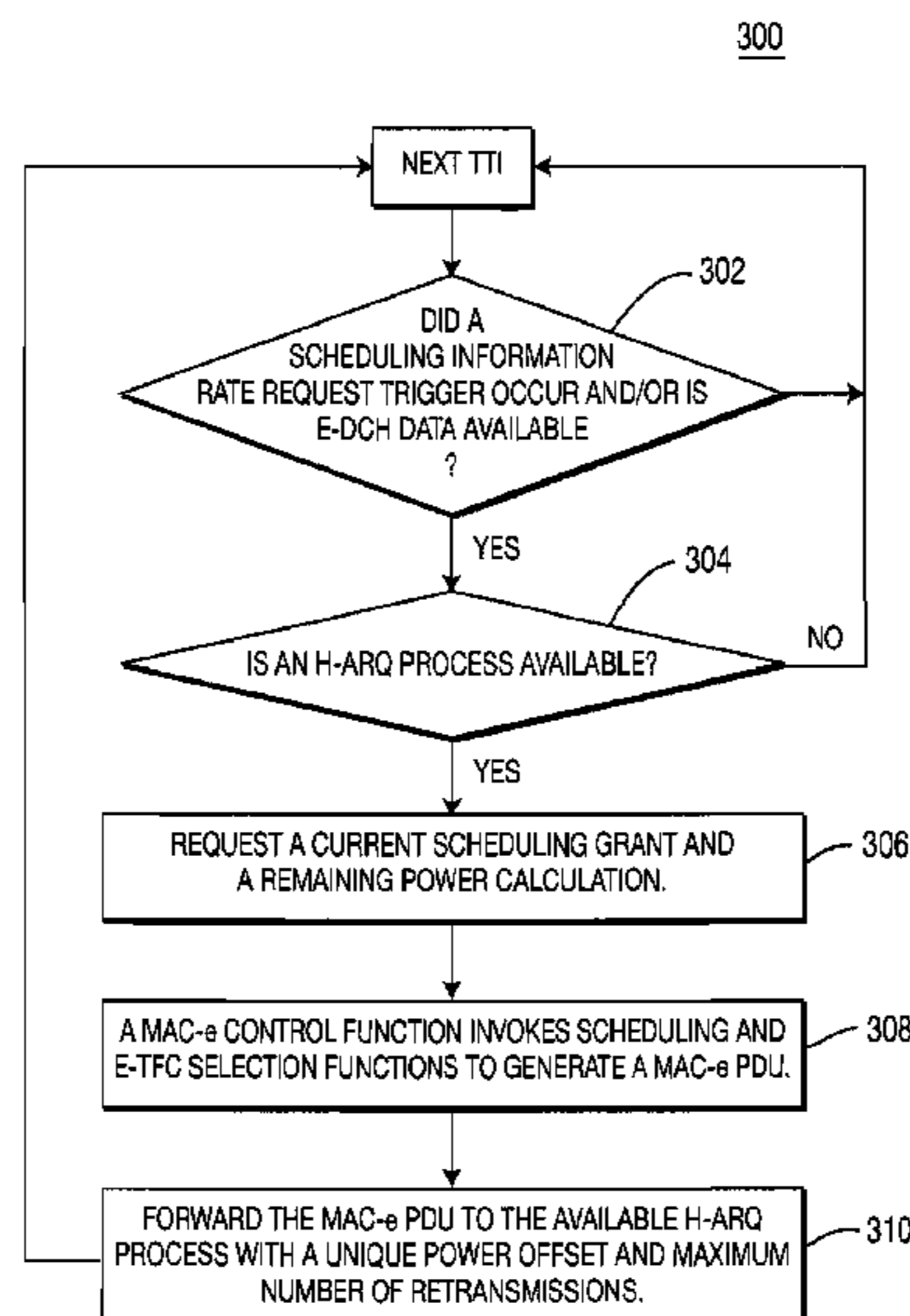

(56)

References Cited

U.S. PATENT DOCUMENTS

7,155,261	B2	12/2006	Chen	
7,161,971	B2	1/2007	Tiedemann, Jr. et al.	
7,382,747	B2	6/2008	Hu et al.	
7,397,790	B2	7/2008	Zeira et al.	
7,408,895	B2	8/2008	Zhang et al.	
7,509,554	B2	3/2009	Lohr et al.	
7,817,597	B2 *	10/2010	Usuda et al.	370/329
7,940,797	B2 *	5/2011	Lee et al.	370/469
7,953,430	B2 *	5/2011	Kwak et al.	455/522
8,694,869	B2 *	4/2014	Grilli et al.	714/776
8,738,062	B2	5/2014	Dick et al.	
8,837,434	B2 *	9/2014	Wang et al.	370/335
2002/0077141	A1	6/2002	Hwang et al.	
2003/0210782	A1	11/2003	Dick et al.	
2003/0232622	A1 *	12/2003	Seo et al.	455/437
2004/0100921	A1 *	5/2004	Khan	370/321
2004/0185892	A1	9/2004	Iacono et al.	
2004/0219917	A1 *	11/2004	Love et al.	455/436
2004/0219919	A1 *	11/2004	Whinnett et al.	455/442
2004/0219920	A1 *	11/2004	Love et al.	455/442
2005/0025100	A1 *	2/2005	Lee et al.	370/335
2005/0030953	A1 *	2/2005	Vasudevan et al.	370/395.4
2005/0043062	A1 *	2/2005	Ahn et al.	455/560
2005/0047416	A1	3/2005	Heo et al.	
2005/0073985	A1 *	4/2005	Heo et al.	370/342
2005/0076173	A1 *	4/2005	Merril et al.	711/100
2005/0079865	A1 *	4/2005	Ahn et al.	455/434
2005/0117559	A1 *	6/2005	Malladi et al.	370/342
2005/0124372	A1	6/2005	Lundby et al.	
2005/0135403	A1 *	6/2005	Ketchum et al.	370/437
2005/0249133	A1 *	11/2005	Terry	H04L 1/0025 370/278
2005/0249138	A1	11/2005	Heo et al.	
2005/0249148	A1 *	11/2005	Nakamata et al.	370/328
2005/0265301	A1 *	12/2005	Heo et al.	370/349
2006/0003787	A1 *	1/2006	Heo et al.	455/522
2006/0111119	A1	5/2006	Iochi	
2006/0120404	A1	6/2006	Sebire et al.	
2006/0143444	A1	6/2006	Malkamaki et al.	H04L 1/0083 713/160
2006/0187844	A1	8/2006	Chun et al.	
2007/0121542	A1	5/2007	Lohr et al.	
2007/0168827	A1	7/2007	Lohr et al.	
2009/0034455	A1	2/2009	Lee et al.	

OTHER PUBLICATIONS

NEC, "Remaining power vs. HS-DPCCH power," TSG-RAN Working Group2 #45bis, R2-050221, Sophia Antipolis, France (Jan. 10-14, 2005).

Panasonic, "E-TFC Selection," 3GPP TSG-RAN WG2#45bis meeting, R2-050065, Sophia Antipolis, France (Jan. 10-14, 2005).

Third Generation Partnership Project, "Technical Specification Group Radio Access Network; Requirements for support of radio resource management (FDD) (Release 1999)," 3GPP TS 25.133 V3.22.0 (Sep. 2005).

Third Generation Partnership Project, "Technical Specification Group Radio Access Network; Requirements for support of radio resource management (FDD) (Release 4)," 3GPP TS 25.133 V4.17.0 (Mar. 2006).

Third Generation Partnership Project, "Technical Specification Group Radio Access Network; FDD Enhanced Uplink; Overall description; Stage 2 (Release 6)," 3GPP TS 25.309 V6.6.0 (Mar. 2006).

Third Generation Partnership Project, "Technical Specification Group Radio Access Network; Requirements for support of radio resource management (FDD) (Release 1999)," 3GPP TS 25.133 V3.20.0 (Mar. 2005).

Third Generation Partnership Project, "Technical Specification Group Radio Access Network; Requirements for support of radio resource management (FDD) (Release 4)," 3GPP TS 25.133 V4.14.0 (Mar. 2005).

Third Generation Partnership Project, "Technical Specification Group Radio Access Network; Requirements for support of radio resource management (FDD) (Release 5)," 3GPP TS 25.133 V5.14.0 (Mar. 2005).

Third Generation Partnership Project, "Technical Specification Group Radio Access Network; Requirements for support of radio resource management (FDD) (Release 5)," 3GPP TS 25.133 V5.17.0 (Dec. 2005).

Third Generation Partnership Project, "Technical Specification Group Radio Access Network; Requirements for support of radio resource management (FDD) (Release 6)," 3GPP TS 25.133 V6.9.0 (Mar. 2005).

Third Generation Partnership Project, "Technical Specification Group Radio Access Network; Requirements for support of radio resource management (FDD) (Release 6)," 3GPP TS 25.133 V6.13.0 (Mar. 2006).

Third Generation Partnership Project, "Technical Specification Group Radio Access Network; Requirements for support of radio resource management (FDD) (Release 6)," 3GPP TS 25.133 V7.3.0 (Mar. 2006).

Third Generation Partnership Project, "Technical Specification Group Radio Access Network; FDD Enhanced Uplink; Overall description; Stage 2 (Release 6)," 3GPP TS 25.309 V6.2.0 (Mar. 2005).

Third Generation Partnership Project, "Technical Specification Group Radio Access Network; Medium Access Control (MAC) protocol specification (Release 1999)," 3GPP TS 25.321 V3.17.0 (Jun. 2004).

Third Generation Partnership Project, "Technical Specification Group Radio Access Network; Medium Access Control (MAC) protocol specification (Release 4)," 3GPP TS 25.321 V4.10.0 (Jun. 2004).

Third Generation Partnership Project, "Technical Specification Group Radio Access Network; Medium Access Control (MAC) protocol specification (Release 5)," 3GPP TS 25.321 V5.10.0 (Dec. 2004).

Third Generation Partnership Project, "Technical Specification Group Radio Access Network; Medium Access Control (MAC) protocol specification (Release 5)," 3GPP TS 25.321 V5.12.0 (Sep. 2005).

Third Generation Partnership Project, "Technical Specification Group Radio Access Network; Medium Access Control (MAC) protocol specification (Release 6)," 3GPP TS 25.321 V6.4.0 (Mar. 2005).

Third Generation Partnership Project, "Technical Specification Group Radio Access Network; Medium Access Control (MAC) protocol specification (Release 6)," 3GPP TS 25.321 V6.8.0 (Mar. 2006).

Third Generation Partnership Project, "Technical Specification Group Radio Access Network; Feasibility Study for Enhanced Uplink for UTRA FDD (Release 6)," 3GPP TR 25.896 V6.0.0 (Mar. 2004).

Third Generation Partnership Project, "Technical Specification Group Radio Access Network; Feasibility Study for Enhanced Uplink for UTRA FDD; (Release 6)," 3GPP TR 25.896 V1.0.0 (Sep. 2003).

* cited by examiner

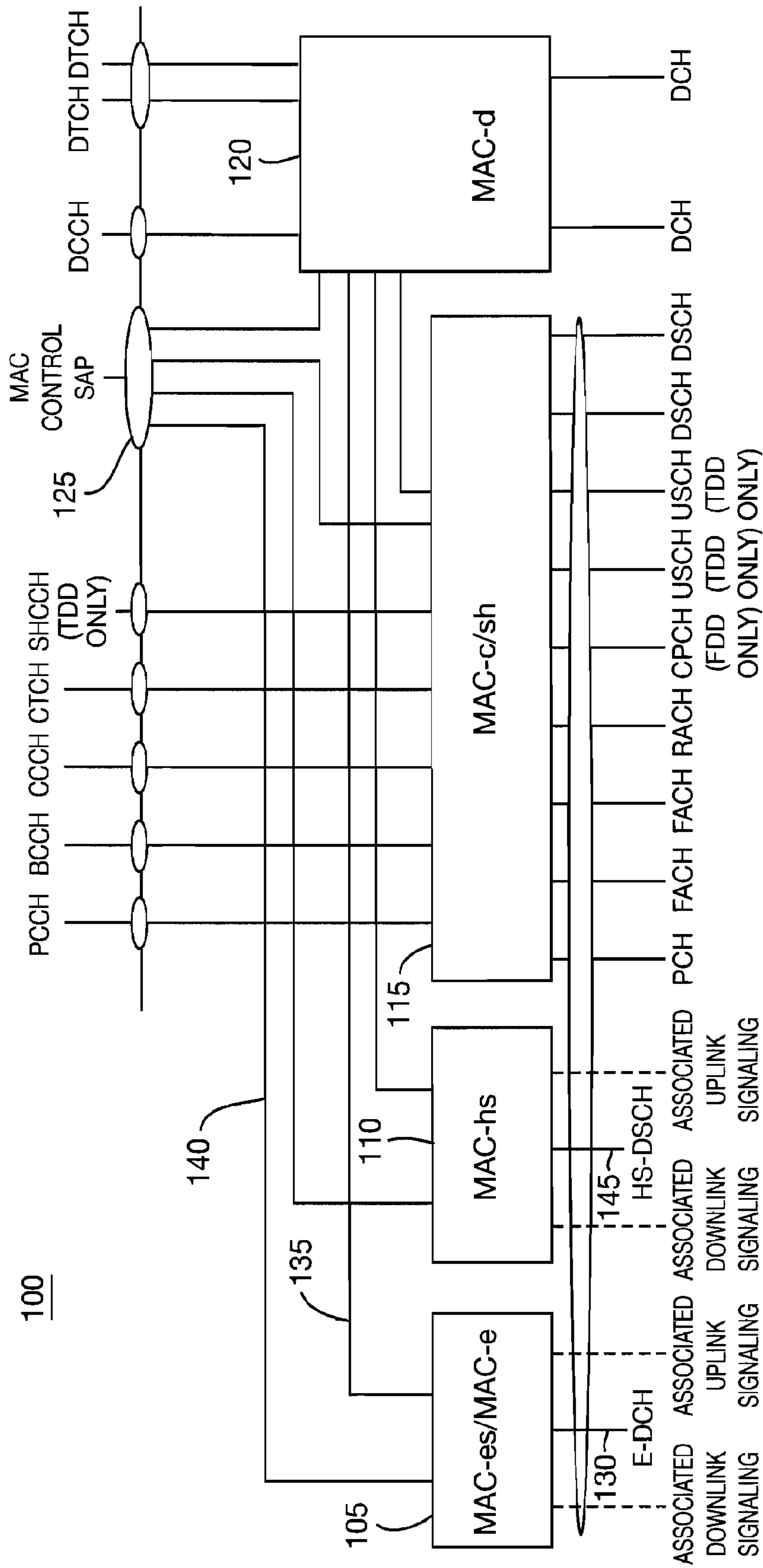

FIG. 1A
PRIOR ART

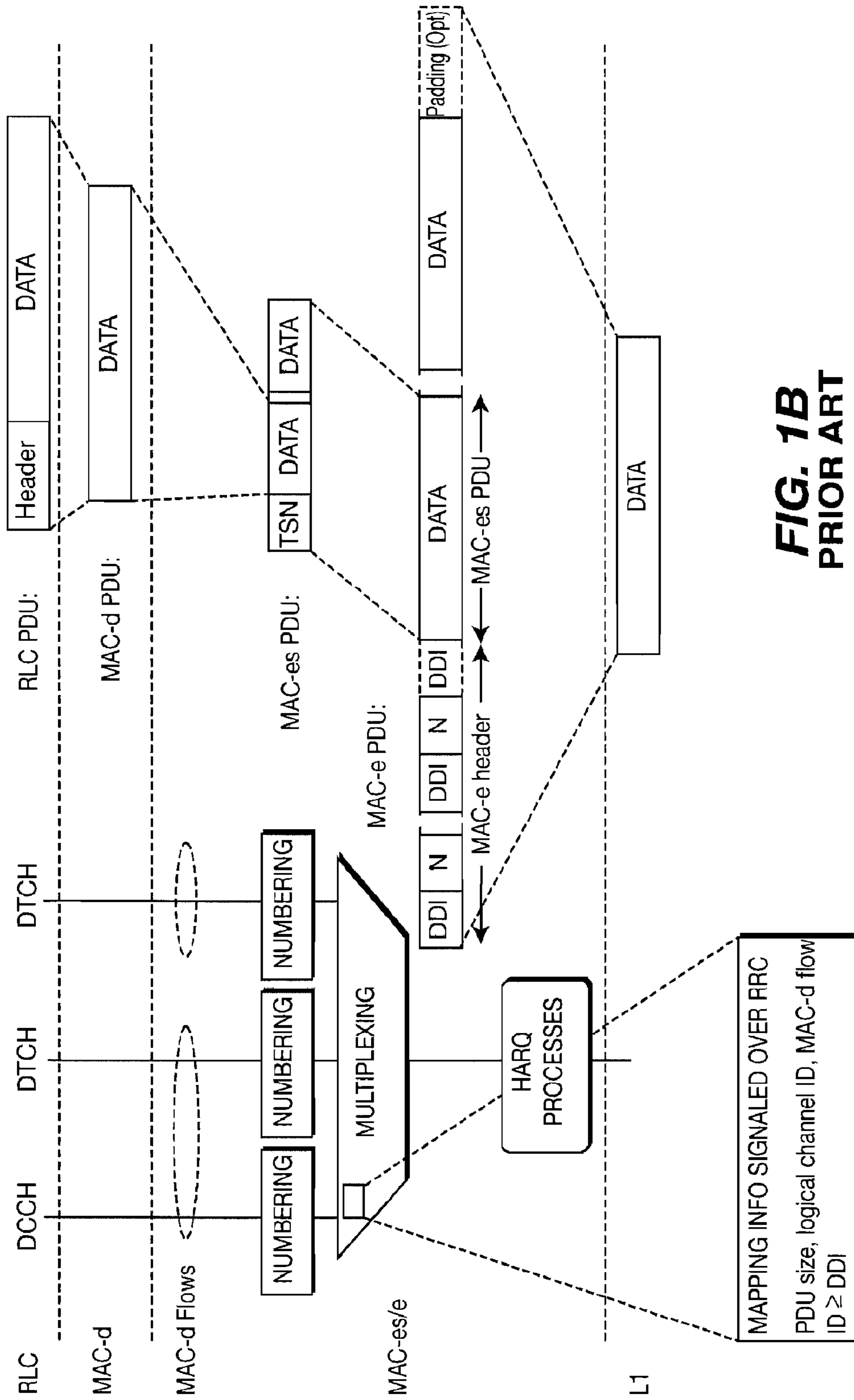

FIG. 1B
PRIOR ART

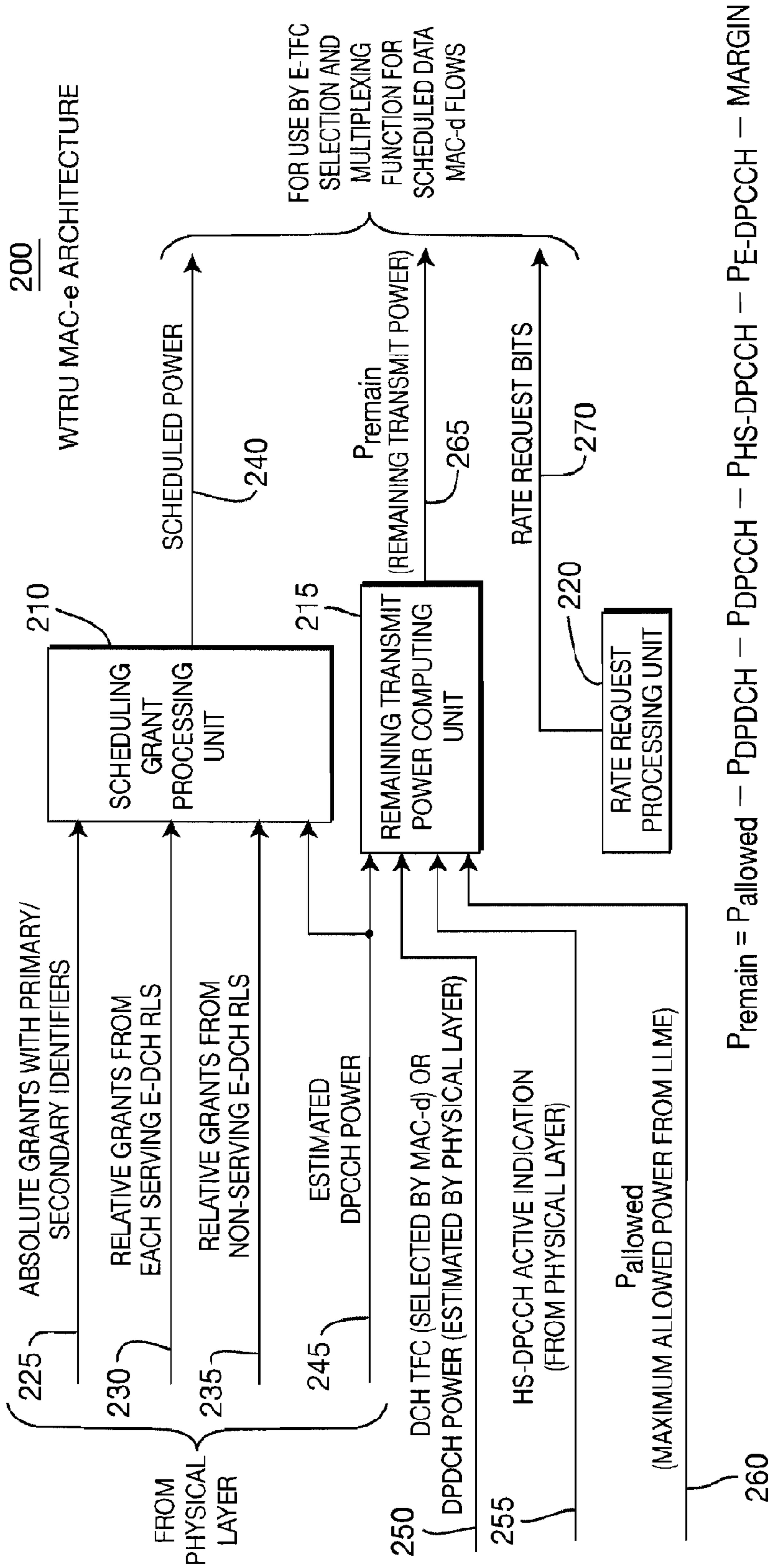

FIG. 2

300

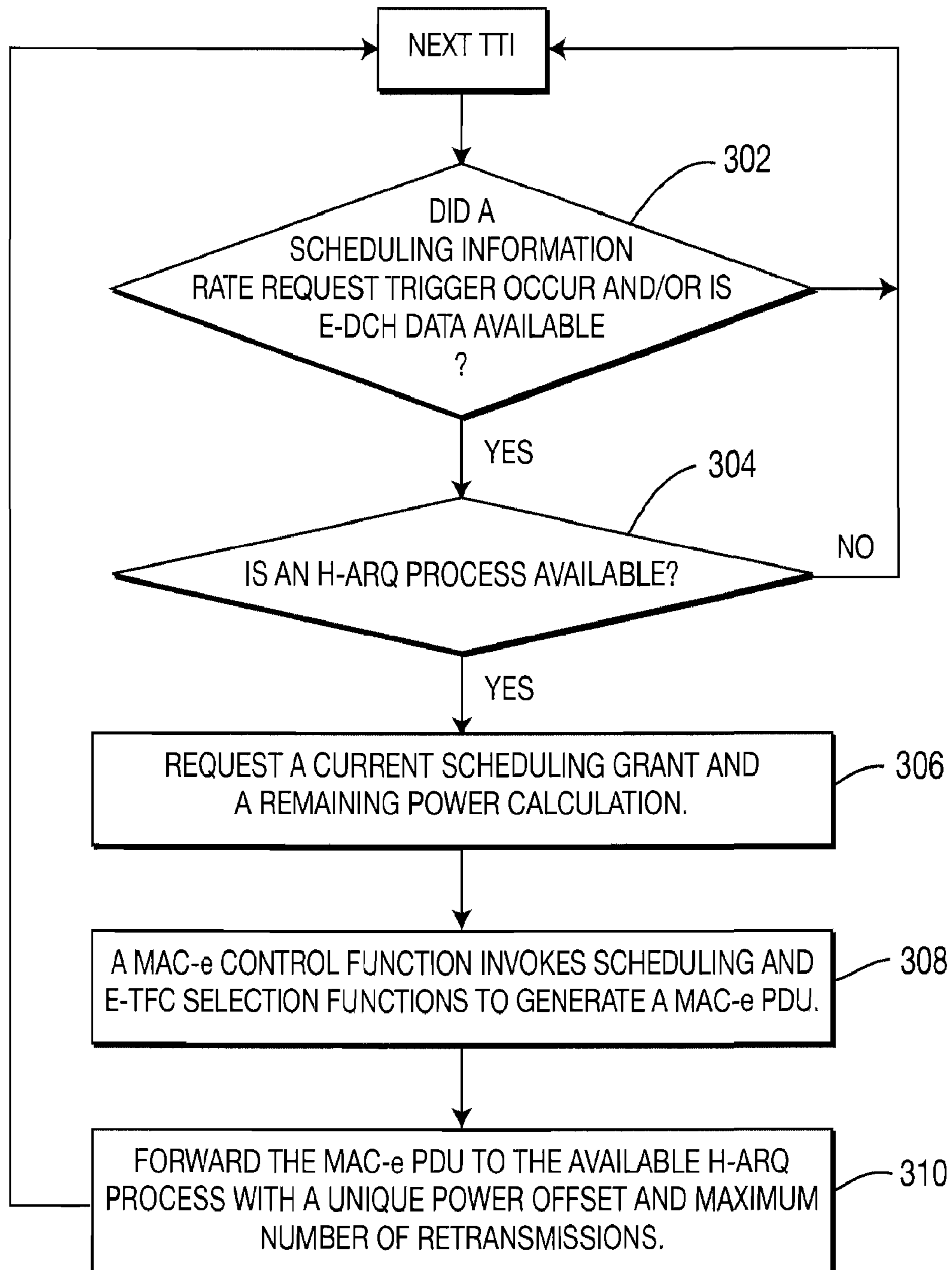

FIG. 3

PRI	TOTAL LOAD (PAYLOAD + HEADER) OF THE COMBINATION	FIRST MAC-d-FLOW IN THE COMBINATION	SECOND MAC-d-FLOW IN THE COMBINATION	SO ON (ACCORDING TO MAC-d-FLOW PRIORITIES IN THE LIST)
1	PAYLOAD SIZE + HEADER SIZE	FORMATTED DDI	FORMATTED DDI	FORMATTED DDI
		NEXT TSN	NEXT TSN	NEXT TSN
		CURRENT TOTAL FLOW SIZE (INCLUDE HEADER SIZE)	CURRENT TOTAL FLOW SIZE (INCLUDE HEADER SIZE)	CURRENT TOTAL FLOW SIZE (INCLUDE HEADER SIZE)
		PDU-SIZE	PDU-SIZE	PDU-SIZE
		NUMBER OF BLOCKS (N)	NUMBER OF BLOCKS (N)	NUMBER OF BLOCKS (N)
1				
2				
SO ON				

FIG. 4

**METHOD AND APPARATUS FOR
SCHEDULING TRANSMISSIONS VIA AN
ENHANCED DEDICATED CHANNEL**

Matter enclosed in heavy brackets [] appears in the original patent but forms no part of this reissue specification; matter printed in italics indicates the additions made by reissue; a claim printed with strikethrough indicates that the claim was canceled, disclaimed, or held invalid by a prior post-patent action or proceeding.

CROSS REFERENCE TO RELATED
APPLICATIONS

This application is a continuation of U.S. patent application Ser. No. 11/402,718 filed Apr. 12, 2006 which issued as U.S. Pat. No. 7,408,895 on Aug. 5, 2008, which claims the benefit of U.S. Provisional Application No. 60/673,076 filed Apr. 20, 2005, which is incorporated by reference as if fully set forth.

FIELD OF INVENTION

The present invention relates to wireless communication systems. More particularly, the present invention is related to a method and apparatus for scheduling transmissions via an enhanced dedicated channel (E-DCH).

BACKGROUND

Methods for improving uplink (UL) coverage, throughput, and transmission latency are currently being investigated in the third generation partnership project (3GPP). In order to achieve these goals, enhanced uplink (EU) transmissions have been proposed in 3GPP, in which control, (i.e., scheduling and assigning), of UL resources, (i.e., physical channels), is moved from a radio network controller (RNC) to a Node-B.

FIG. 1A shows a conventional wireless transmit/receive unit (WTRU), (e.g., mobile station), side medium access control (MAC) architecture **100**. The WTRU MAC architecture **100** includes a MAC-es/MAC-e entity **105**, which comprises different independent sub-layer entities within the MAC. The MAC-es/-e functionality split is a result of how the MAC functionality is partitioned within the universal terrestrial radio access network (UTRAN). The WTRU MAC architecture **100** further includes a high speed MAC entity **110**, a MAC-c/sh **115**, a dedicated channel MAC (MAC-d) **120** and a MAC control service access point (SAP) **125**. The MAC-c/sh **115** controls access to all common transport channels, except the HS-DSCH transport channel **145**. The MAC-d **120** controls access to all dedicated transport channels, to the MAC-c/sh **115** and the MAC-hs **110**. The MAC-hs **110** controls access to the HS-DSCH transport channel **145**.

The MAC-es/MAC-e entity **105** controls access to an E-DCH **130**, whereby the MAC-d **120** may access the E-DCH **130** via a connection **135**, and the MAC control SAP **125** may access the E-DCH **130** via a connection **140**.

FIG. 1B shows MAC interworking in the conventional WTRU of FIG. 1A. As shown in FIG. 1B, a radio link control (RLC) protocol data unit (PDU) enters the MAC-d on a logical channel. In the MAC-e header, a data description indicator (DDI) field, (6 bits), identifies the logical channel, MAC-d flow and MAC-d PDU size. A mapping table is signaled over radio resource control (RRC) signaling

to allow the WTRU to set the DDI values. The N field, (fixed size of 6 bits), indicates the number of consecutive MAC-d PDUs corresponding to the same DDI value. A special value of the DDI field indicates that no more data is contained in the remaining part of the MAC-e PDU. The transmission sequence number (TSN) field (6 bits) provides the transmission sequence number on the E-DCH **130** shown in FIG. 1A. The MAC-e PDU is forwarded to a hybrid-automatic repeat request (H-ARQ) entity, which then forwards the MAC-e PDU to layer **1** for transmission in one transmission time interval (TTI).

An efficient MAC architecture for scheduling the transmission of E-DCH data is desired.

SUMMARY

The present invention is related to a method and apparatus for scheduling transmissions via an E-DCH. A scheduled power is calculated for scheduled data flows. A remaining transmit power is calculated for the E-DCH transmission. A rate request message is generated, wherein the scheduled power, remaining transmit power and rate request message are used to select transport format combinations (TFCs) and multiplex data scheduled for the E-DCH transmission. The remaining transmit power is calculated by subtracting from a maximum allowed power the power of a dedicated physical data channel (DPDCH), a dedicated physical control channel (DPCCH), a high speed dedicated physical control channel (HS-DPCCH), an enhanced uplink dedicated physical control channel (E-DPCCH) and a power margin.

BRIEF DESCRIPTION OF THE DRAWINGS

A more detailed understanding of the invention may be had from the following description of a preferred example, given by way of example and to be understood in conjunction with the accompanying drawings wherein:

FIG. 1A shows a conventional WTRU side MAC architecture;

FIG. 1B prior art MAC inter-working in the conventional WTRU of FIG. 1A;

FIG. 2 shows a WTRU MAC-e architecture configured in accordance with the present invention;

FIG. 3 is a flow diagram of a MAC-e scheduling process in accordance with the present invention; and

FIG. 4 shows an example of a pre-processed MAC-e PDU format in accordance with the present invention.

DETAILED DESCRIPTION OF THE
PREFERRED EMBODIMENTS

Hereafter, the terminology "WTRU" includes but is not limited to a user equipment (UE), a mobile station, a fixed or mobile subscriber unit, a pager, or any other type of device capable of operating in a wireless environment. When referred to hereafter, the terminology "Node-B" includes but is not limited to a base station, a site controller, an access point or any other type of interfacing device in a wireless environment.

Hereinafter, the terminology "MAC-e" will be used to reference both MAC-e and MAC-es collectively.

The features of the present invention may be incorporated into an integrated circuit (IC) or be configured in a circuit comprising a multitude of interconnecting components.

FIG. 2 shows a WTRU MAC-e architecture **200** configured in accordance with the present invention. The WTRU MAC-e architecture **200** includes a scheduling grant pro-

cessing unit **210**, a remaining transmit power computing unit **215** and a rate request processing unit **220**.

The scheduling grant processing unit **210** receives at least one scheduling grant from at least one radio link set (RLS) and derives a current scheduling grant. The scheduling grant may be an absolute grant **225** received from a serving E-DCH cell with a primary or secondary identifier, (i.e., an E-DCH radio network temporary identifier (E-RNTI) is used to determine if the absolute grant is primary or secondary), a relative grant **230** received from a serving E-DCH RLS or a relative grant **235** received from a non-serving E-DCH RLS. The scheduling grant processing unit **210** outputs a signal **240** indicating the amount of scheduled power for use by an E-TFC selection and multiplexing function for scheduled data MAC-d flows.

The amount of scheduled power may be identified as a ratio to the DPCCH power. For example, if the DPCCH power is P , the amount of scheduled power has a ratio of 2 to the DPCCH power. Thus, the amount of scheduled power is $2P$. Alternatively, the amount of scheduled power can be identified as the maximum transmit power that can be used for scheduled data to avoid the E-TFC selection and multiplexing function to be aware of DPCCH power measurements. Since DPCCH power changes rapidly, there is processing overhead if it has to be propagated to different entities within the MAC. Furthermore, it is complex to synchronize the timing. Therefore, having only one entity in the MAC-e aware of the DPCCH power is preferred since other scheduling related functions require knowledge of current DPCCH power.

When the MAC-e entity **105** invokes the MAC-e function, the scheduling grant processing unit **210** determines the current serving grant. The physical layer provides absolute grants **225** received from the AGCH, indicating whether the grant was received with a primary or secondary E-RNTI. The physical layer also provides relative grants **230**, **235** received from each RLS, indicating if the RLS is either a serving E-DCH RLS or a non-serving E-DCH RLS. Absolute grants **225** are signaled as the ratio to the current UL DPCCH power. Absolute grants **225** received with a primary E-RNTI always reset the current serving grant. Absolute grants received with a secondary E-RNTI only affect the current serving grant if previously set by a secondary E-RNTI or the grant is set to zero.

Relative grants **230** from the serving E-DCH RLS adjust the serving grant in steps up, or down. Relative grants for the non-serving E-DCH RLS can only lower the serving grant by one step. When a relative grant down from a non-serving E-DCH RLS is received, a hysteresis period is started during which other relative grant downs are ignored.

The remaining transmit power computing unit **215** receives a signal **245** indicating current DPCCH power estimated by the physical layer, a signal **250** indicating an DCH TFC selected by the MAC-d or DPDCH power estimated by the physical layer, a signal **255** for indicating HS-DPCCH active from the physical layer and a signal **260** indicating maximum allowed power (with a power margin) from a lower layer management entity (LLME) configured by the radio resource controller (RRC). If the HS-DPCCH is active, its power (and power from other channels) must be subtracted from the maximum power to determine the remaining power. Based on signals **245**, **250**, **255** and **260**, the remaining transmit power computing unit **215** outputs a signal **265** indicating a remaining transmit power (P_{remain}) which is computed in accordance with the following equation (1):

$$P_{remain} = P_{allowed} - P_{DPDCH} - P_{DPCCH} - P_{HS-DPCCH} - P_{E-DPCCH} - \text{Margin}; \quad \text{Equation (1)}$$

where P_{DPCCH} , P_{DPDCH} , $P_{HS-DPCCH}$ and $P_{E-DPCCH}$ represent power requirements of the DPCCH, the DPDCH, the HS-DPCCH and the E-DPCCH, respectively. The rate request processing unit **220** monitors triggering events for rate requests, and triggers a scheduling information rate request when a triggering event occurs. The rate request processing unit **220** provides logic for triggering the rate request and logic for constructing a rate request message **270** including rate request bits.

The rate request may be triggered when new data on logical channels mapped to the E-DCH is received when there is no current scheduling grant, new data of a higher priority than last reported is received on a logical channel mapped to the E-DCH, when there is no scheduling grant and rate requests are updated and periodically generated, (which is configured by RRC procedures), and when a serving RLS acknowledgement (ACK) is not received for the previously transmitted rate request, an updated rate request is generated.

The rate request includes the total buffer occupancy for all scheduled MAC-d flows, the highest priority data buffer occupancy for any scheduled MAC-d flow, and a power head-room available for E-DCH transmission.

Referring to FIG. 3, a MAC-e scheduling process **300** is explained hereinafter. For each E-DCH TTI, the E-DCH is monitored and it is determined whether a scheduling information rate request trigger occurs and/or whether there is E-DCH data with a grant available (step **302**). If no rate request trigger occurs or there is no E-DCH data available, the process waits until the next TTI. If the determination at step **302** is positive, it is further determined whether there is an H-ARQ process available (step **304**). Availability of an H-ARQ process is required before E-TFC selection and E-DCH data transmission. If there is no available H-ARQ process, the process **300** waits until the next TTI. If an H-ARQ process is determined to be available at step **304**, a current scheduling grant and remaining transmit power calculation are requested from the scheduling grant processing unit **210** and the remaining transmit power computing unit **215**, respectively (step **306**). In step **308**, a MAC-e control function invokes scheduling and E-TFC selection functions to generate a MAC-e PDU. In step **310**, the MAC-e PDU is then forwarded to the available H-ARQ process with a unique power offset and maximum number of retransmissions.

In a separate embodiment to meet the timing requirement of the MAC-e PDU formation, pre-calculation of the possible MAC-e PDUs for speeding up the formation process is employed. When the MAC-e entity is requested with the remaining power budget for the E-DCH transmission, the formation process searches the pre-formatted MAC-e PDU table, (mainly its formatted MAC-e PDU header and appropriated data block PDUs), providing ready information to the H-ARQ/physical layer. There are a number of ways for performing the preprocessing, depending on the timing requirement.

FIG. 4 shows an example of a preprocessed MAC-e PDU format in accordance with the present invention. The preprocessed MAC-e PDU format consists of a power budget for E-DCH or equivalent, a fully formatted MAC-e PDU header optimally fitting the budget or equivalent, a list of transmission sequence numbers (TSNs) and data block pointers, scheduling information and padding bits.

5

The power budget for E-DCH includes a number of predicted power or equivalent situations based on the last transmission power and the prediction of the current possible power budget. The MAC-e PDU header is formatted based on this budget and the data priority on the same row. The fully formatted MAC-e PDU header describes the MAC-e PDU, with the logical channel priority considered, and the scheduled and non-scheduled data and budget considered. The header includes the DDI, N and the DDI-terminator. A list of the MAC-es PDUs descriptors, including the TSN and data pointers to the MAC-es data blocks, correspond to the same row pre-formatted PDU header. Scheduling information may go with the MAC-e PDU if it exists. Padding bits indicate the number of bits to be padded at the end of the MAC-e PDU for that particular row. The full formation can use the following partial formation: power budget for E-DCH or Equivalent, DDI, scheduled or non-scheduled. This sorted list is based on the data priority. Each row is a MAC-d-flow. (MAC-es PDUs). The power budget is a list of predicted power budget. The DDI represents the MAC-d-flow-ID, logical channel ID and the PDU size. The scheduled or non-scheduled column indicates that the PDUs consume the non-scheduled power budget or scheduled power budget. Non-scheduled data can also be used with scheduled information in the Mac-e PDU.

Although the features and elements of the present invention are described in the preferred embodiments in particular combinations, each feature or element can be used alone without the other features and elements of the preferred embodiments or in various combinations with or without other features and elements of the present invention.

What is claimed is:

1. A method of scheduling uplink data transmissions via an enhanced dedicated channel (E-DCH), the method comprising:

calculating a scheduled power for scheduled data flows by a scheduling grant processing unit; and
calculating a remaining transmit power for the E-DCH transmission by a remaining transmit power computing unit, wherein the remaining transmit power is calculated by subtracting from a maximum allowed power the power of a dedicated physical data channel (DPDCH), a dedicated physical control channel (DPCCCH), a high speed dedicated physical control channel (HS-DPCCH), an enhanced uplink dedicated physical control channel (E-DPCCH) and a power margin.

2. The method of claim 1 further comprising:
providing an integrated circuit incorporating the scheduling grant processing unit, the remaining transmit power computing unit and a rate request processing unit; and

generating a rate request message by the rate request processing unit, wherein the scheduled power, remaining transmit power and rate request message are used to select transport format combinations (TFCs) and multiplex data scheduled for the E-DCH transmission.

3. The method of claim 2 further comprising:
providing logic for triggering the rate request message; and
providing logic for constructing the rate request message, wherein the rate request message includes a plurality of rate request bits.

4. The method of claim 2 wherein the rate request message indicates total buffer occupancy for any scheduled dedicated channel medium access channel (MAC) data flows and a power headroom available for E-DCH data transmission.

6

5. The method of claim 2 wherein the rate request message is triggered when there is no current scheduling grant, and new data is received on logical channels mapped to the E-DCH.

6. The method of claim 2 wherein the rate request message is triggered when new data of a higher priority than last reported is received on a logical channel mapped to the E-DCH.

7. The method of claim 2 wherein the rate request message is triggered when there is no scheduling grant and rate requests are updated and periodically generated.

8. The method of claim 2 wherein an updated rate request message is generated when a serving radio link set (RLS) acknowledgement (ACK) is not received for the previously transmitted rate request message.

9. The method of claim 1 wherein at least one scheduling grant received from at least one radio link set (RLS) is used to calculate the scheduled power.

10. The method of claim 9 wherein the at least one scheduling grant is an absolute grant received from an E-DCH cell with a primary or secondary identifier.

11. The method of claim 9 wherein the at least one scheduling grant is a relative grant received from a serving E-DCH radio link set.

12. The method of claim 9 wherein the at least one scheduling grant is a relative grant received from a non-serving E-DCH radio link set.

13. A wireless transmit/receive unit (WTRU) configured to establish an enhanced dedicated channel (E-DCH) for uplink transmissions and scheduling data transmissions via the E-DCH, the WTRU comprising:

a scheduling grant processing unit configured to calculate a scheduled power for scheduled data flows; and

a remaining power computing unit configured to calculate a remaining transmit power for E-DCH transmission, wherein the remaining transmit power is calculated by subtracting from a maximum allowed power the power of a dedicated physical data channel (DPDCH), a dedicated physical control channel (DPCCCH), a high speed dedicated physical control channel (HS-DPCCH), an enhanced uplink dedicated physical control channel (E-DPCCH) and a power margin.

14. The WTRU of claim 13 further comprising:

a rate request processing unit configured to generate a rate request message, wherein the scheduled power, remaining transmit power and rate request message are used to select transport format combinations (TFCs) and multiplex data scheduled for the E-DCH transmission wherein the scheduling grant processing unit, the remaining power computing unit and the rate request processing unit are incorporated into an integrated circuit.

15. The WTRU of claim 14 wherein the rate request processing unit comprises logic for triggering the rate request message and logic for constructing the rate request message, wherein the rate request message includes a plurality of rate request bits.

16. The WTRU of claim 14 wherein the rate request message indicates total buffer occupancy for any scheduled dedicated channel medium access channel (MAC) data flows and a power headroom available for E-DCH data transmission.

17. The WTRU of claim 14 wherein the rate request message is triggered when there is no current scheduling grant, and new data is received on logical channels mapped to the E-DCH.

18. The WTRU of claim 13 wherein at least one scheduling grant received from at least one radio link set (RLS) is used to calculate the scheduled power.

19. The WTRU of claim 18 wherein the at least one scheduling grant is an absolute grant received from an E-DCH cell with a primary or secondary identifier.

20. The WTRU of claim 18 wherein the at least one scheduling grant is a relative grant received from a serving E-DCH radio link set.

21. The WTRU of claim 18 wherein the at least one scheduling grant is a relative grant received from a non-serving E-DCH radio link set.

22. A wireless transmit/receive unit (WTRU) comprising:
an integrated circuit configured to trigger scheduling information;

the integrated circuit configured to determine a serving grant;

the integrated circuit configured to determine a remaining transmit power;

the integrated circuit configured to select a size of a medium access control-e (MAC-e) protocol data unit (PDU) based on the serving grant, the triggered scheduling information and the remaining transmit power; and

a transmitter operatively coupled to the integrated circuit, the transmitter configured to transmit the MAC-e PDU.

23. The WTRU of claim 22 wherein the remaining transmit power is derived based on a selected transport format combination for a dedicated channel.

24. The WTRU of claim 22 wherein the remaining transmit power is derived based on subtracting a dedicated physical data channel estimated power, a dedicated physical control channel estimated power and an enhanced uplink dedicated physical control channel uplink power from a maximum allowed power.

25. The WTRU of claim 24 wherein the remaining transmit power is further derived by subtracting a high speed downlink physical control channel estimated power from the maximum allowed power.

26. The WTRU of claim 24 wherein the remaining transmit power is further derived by subtracting a margin from the maximum allowed power.

27. The WTRU of claim 22 wherein the scheduling information includes a total buffer occupancy for scheduled MAC-d flows and a buffer occupancy for a highest priority MAC-d flow.

28. The WTRU of claim 22 wherein the integrated circuit is further configured to trigger scheduling information based on periodic triggering configured by radio resource control procedure.

29. A wireless transmit/receive unit (WTRU) comprising:
an integrated circuit configured to trigger scheduling information based on a condition that higher priority data is received and a current scheduling grant is zero;

the integrated circuit configured to determine a serving grant;

the integrated circuit configured to select a size of a medium access control-e (MAC-e) protocol data unit (PDU) based on the serving grant and the triggered scheduling information; and

a transmitter operatively coupled to the integrated circuit, the transmitter configured to transmit the MAC-e PDU.

30. A method comprising:

triggering scheduling information, by a wireless transmit/receive unit (WTRU);

determining, by the WTRU, a serving grant;

determining, by the WTRU, a remaining transmit power;

selecting a size of a medium access control-e (MAC-e) protocol data unit (PDU), by the WTRU, based on the serving grant, the triggered scheduling information and the remaining transmit power; and

transmitting, by the WTRU, the MAC-e PDU.

31. The method of claim 30 wherein the remaining transmit power is derived based on a selected transport format combination for a dedicated channel.

32. The method of claim 30 wherein the remaining transmit power is derived based on subtracting a dedicated physical data channel estimated power, a dedicated physical control channel estimated power and an enhanced uplink dedicated physical control channel uplink power from a maximum allowed power.

33. The method of claim 32 wherein the remaining transmit power is further derived by subtracting a high speed downlink physical control channel estimated power from the maximum allowed power.

34. The method of claim 32 wherein the remaining transmit power is further derived by subtracting a margin from the maximum allowed power.

35. The method of claim 30 wherein the scheduling information includes a total buffer occupancy for scheduled MAC-d flows and a buffer occupancy for a highest priority MAC-d flow.

36. The method of claim 30 wherein the triggering scheduling information is based on periodic triggering configured by radio resource control procedure.

37. A method comprising:

triggering scheduling information, by a wireless transmit/receive unit (WTRU) based on a condition that higher priority data is received and a current scheduling grant is zero;

determining, by the WTRU, a serving grant;

selecting a size of a medium access control-e (MAC-e) protocol data unit (PDU), by the WTRU, based on the serving grant and the triggered scheduling information; and

transmitting, by the WTRU, the MAC-e PDU.

38. A Node B comprising:

a transmitter operatively coupled to an integrated circuit, the transmitter and the integrated circuit configured to transmit absolute grants and relative grants to a wireless transmit/receive unit (WTRU); and

a receiver operatively coupled to the integrated circuit, the receiver configured to receive an enhanced uplink transmission from the WTRU including a medium access control-e (MAC-e) protocol data unit (PDU) having a size derived from triggered scheduling information and a scheduling grant; wherein the scheduling grant being derived from at least one of the transmitted absolute grants and at least one of the transmitted relative grants; and wherein the scheduling information was triggered based on a condition that higher priority data is received and a current scheduling grant is zero.

39. The Node B of claim 38 wherein the triggered scheduling information includes a total buffer occupancy for scheduled MAC-d flows and a buffer occupancy for a highest priority MAC-d flow.

40. A method comprising:

transmitting, by a Node B, absolute grants and relative grants to a wireless transmit/receive unit (WTRU); and

receiving an enhanced uplink transmission, by the Node B, from the WTRU including a medium access control-e (MAC-e) protocol data unit (PDU) having a size derived from triggered scheduling information and a

scheduling grant; wherein the scheduling grant being derived from at least one of the transmitted absolute grants and at least one of the transmitted relative grants; and wherein the scheduling information was triggered based on a condition that higher priority data is received and a current scheduling grant is zero. 5

41. The method of claim 40 wherein the triggered scheduling information includes a total buffer occupancy for scheduled MAC-d flows and a buffer occupancy for a highest priority MAC-d flow. 10

* * * * *