



US00RE46220E

(19) **United States**
(12) **Reissued Patent**
Georgitsis et al.

(10) **Patent Number: US RE46,220 E**
(45) **Date of Reissued Patent: *Nov. 29, 2016**

(54) **AUXILIARY LIGHTING SYSTEMS**

(71) Applicant: **VISION MOTOR SPORTS, INC.**,
Algona, WA (US)

(72) Inventors: **Anthony C. Georgitsis**, Algona, WA
(US); **Nicholas B. Irwin**, Algona, WA
(US); **Joseph Biro**, Scottsdale, AZ (US)

(73) Assignee: **Vision Motor Sports, Inc.**, Algona, WA
(US)

(*) Notice: This patent is subject to a terminal disclaimer.

(21) Appl. No.: **13/907,007**

(22) Filed: **May 31, 2013**

Related U.S. Patent Documents

Reissue of:

(64) Patent No.: **7,950,821**
Issued: **May 31, 2011**
Appl. No.: **12/247,145**
Filed: **Oct. 7, 2008**

U.S. Applications:

(60) Provisional application No. 60/983,120, filed on Oct. 26, 2007, provisional application No. 61/060,767, filed on Jun. 11, 2008.

(51) **Int. Cl.**

F21V 21/30 (2006.01)
F21V 14/02 (2006.01)
F21V 13/14 (2006.01)
F21V 29/00 (2006.01)
B60Q 1/04 (2006.01)
B60Q 1/18 (2006.01)

(52) **U.S. Cl.**

CPC **F21V 21/30** (2013.01); **B60Q 1/0483**
(2013.01); **F21V 14/02** (2013.01); **B60Q 1/18**
(2013.01); **F21V 13/14** (2013.01); **F21V**
29/2206 (2013.01)

(58) **Field of Classification Search**

CPC F21Y 2101/02; F21Y 2103/00; F21Y
2103/003; F21V 15/01; F21V 21/30; F21V
19/008; F21V 7/005; F21V 21/005; F21V
21/00; F21V 19/003; F21V 21/14; F21V
14/06; F21V 5/007; F21V 23/04; F21V
29/20; F21V 29/22; F21V 15/04; F21V
15/011; F21V 29/2262; F21V 29/2218;
F21V 29/2206; F21V 29/2212; F21V
29/2243; F21V 29/225; F21V 29/002;
F21V 29/004; F21S 4/008; F21S 4/003;
B62K 19/40; B60Q 1/2611; B60Q 1/52;
B60Q 1/0483; B60Q 1/18
USPC 362/217.12, 220, 232, 245, 327, 370,
362/371, 418, 419, 430, 217.13, 217.14,
362/217.16, 217.17, 267, 269, 270, 369,
362/390, 427, 218, 373

See application file for complete search history.

(56) **References Cited**

U.S. PATENT DOCUMENTS

826,205 A 7/1906 Whitehouse
2,740,883 A * 4/1956 Kruger 362/219
4,101,957 A 7/1978 Chang
4,151,584 A 4/1979 Labrum
4,392,187 A 7/1983 Bornhorst

(Continued)

Primary Examiner — Henry Tran

(74) *Attorney, Agent, or Firm* — Mark J. Nahnsen; Barnes
& Thornburg LLP

(57) **ABSTRACT**

Vehicle-mounted auxiliary lighting systems adapted to provide primary or auxiliary vehicle lighting using light emitting diodes (LEDs) are disclosed.

23 Claims, 17 Drawing Sheets

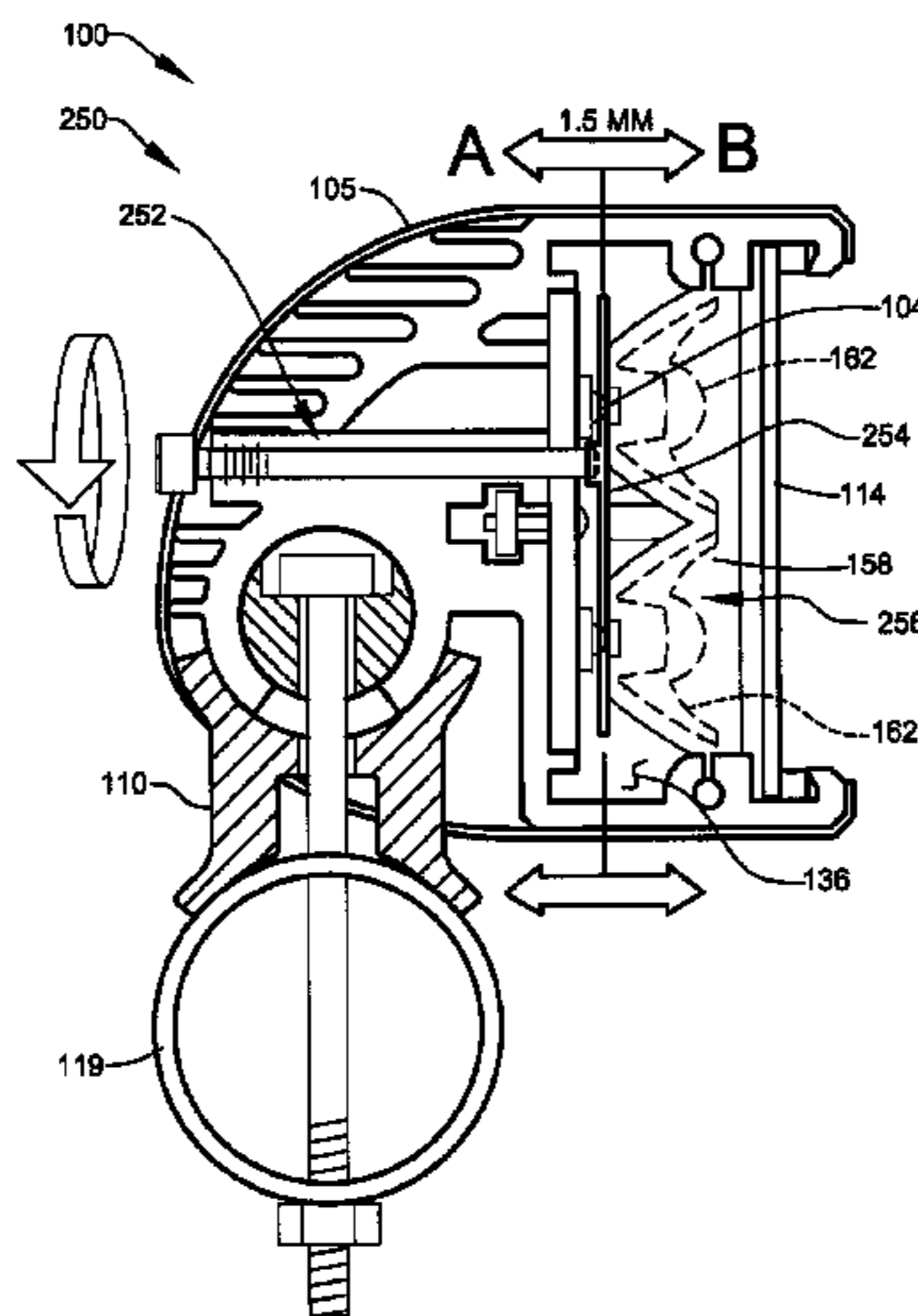

US RE46,220 E

(56)

References Cited

U.S. PATENT DOCUMENTS

4,500,947 A 2/1985 Perkins
 4,528,618 A * 7/1985 Bitsch 362/33
 4,530,040 A 7/1985 Petterson
 4,583,153 A 4/1986 Tsuyama
 4,698,730 A 10/1987 Sakai et al.
 4,745,531 A 5/1988 Leclercq
 4,803,605 A 2/1989 Schaller et al.
 4,814,950 A 3/1989 Nakata
 4,941,070 A 7/1990 Ogawa et al.
 4,959,757 A 9/1990 Nakata
 4,962,450 A 10/1990 Reshetin
 5,057,978 A * 10/1991 Conti 362/125
 5,060,120 A 10/1991 Kobayashi et al.
 5,072,346 A 12/1991 Harding
 5,103,381 A 4/1992 Uke
 5,249,109 A 9/1993 Denison et al.
 5,268,977 A 12/1993 Miller
 5,282,121 A 1/1994 Bornhorst et al.
 5,526,248 A 6/1996 Endo
 5,577,493 A 11/1996 Parkyn, Jr. et al.
 5,593,225 A * 1/1997 Safyan 362/427
 5,630,661 A 5/1997 Fox
 5,673,990 A 10/1997 Neumann et al.
 5,711,590 A 1/1998 Gotoh et al.
 5,808,775 A 9/1998 Inagaki et al.
 5,897,196 A 4/1999 Soskind et al.
 5,899,559 A 5/1999 Lachmayer et al.
 5,904,417 A 5/1999 Hewett
 5,934,795 A 8/1999 Rykowski et al.
 5,954,428 A 9/1999 Eichhorn et al.
 5,986,779 A 11/1999 Tanaka et al.
 6,007,210 A 12/1999 Yamamoto et al.
 6,123,440 A 9/2000 Albou

6,166,371 A * 12/2000 Milbrath et al. 250/221
 6,220,736 B1 4/2001 Dobler et al.
 6,227,685 B1 5/2001 McDermott
 6,231,209 B1 5/2001 Leibig et al.
 6,252,338 B1 6/2001 Bergman et al.
 6,280,071 B1 8/2001 Yamamoto et al.
 6,354,721 B1 3/2002 Zattoni
 6,406,171 B1 6/2002 Satsukawa et al.
 6,536,899 B1 3/2003 Fiala
 6,547,423 B2 4/2003 Marshall et al.
 6,575,609 B2 6/2003 Taniuchi et al.
 6,575,610 B2 6/2003 Natsume
 6,603,243 B2 8/2003 Parkyn et al.
 6,652,117 B2 * 11/2003 Tsai 362/221
 6,710,325 B2 3/2004 Kuhar
 6,741,406 B2 5/2004 Kitamura et al.
 6,796,690 B2 9/2004 Bohlander
 6,827,467 B2 12/2004 Tenmyo
 6,866,401 B2 * 3/2005 Sommers et al. 362/268
 6,932,490 B2 8/2005 Emil et al.
 6,966,682 B2 * 11/2005 Frank et al. 362/544
 6,986,593 B2 1/2006 Rhoads et al.
 7,114,832 B2 10/2006 Holder et al.
 7,226,185 B2 * 6/2007 Dolgin et al. 362/239
 7,258,459 B2 * 8/2007 Wang 362/101
 7,281,820 B2 * 10/2007 Bayat et al. 362/245
 7,600,887 B2 * 10/2009 Sherman 362/217.1
 7,775,679 B2 * 8/2010 Thrailkill et al. 362/237
 8,192,063 B2 * 6/2012 Neufeglise 362/541
 8,277,077 B2 * 10/2012 Georgitsis B60Q 1/0483
 362/217.12
 2002/0145884 A1 10/2002 Yamamoto
 2003/0007359 A1 1/2003 Sugawara et al.
 2003/0090906 A1 5/2003 Hayakawa
 2004/0017685 A1 1/2004 Dedoro
 2010/0014286 A1 * 1/2010 Yoneda et al. 362/231

* cited by examiner

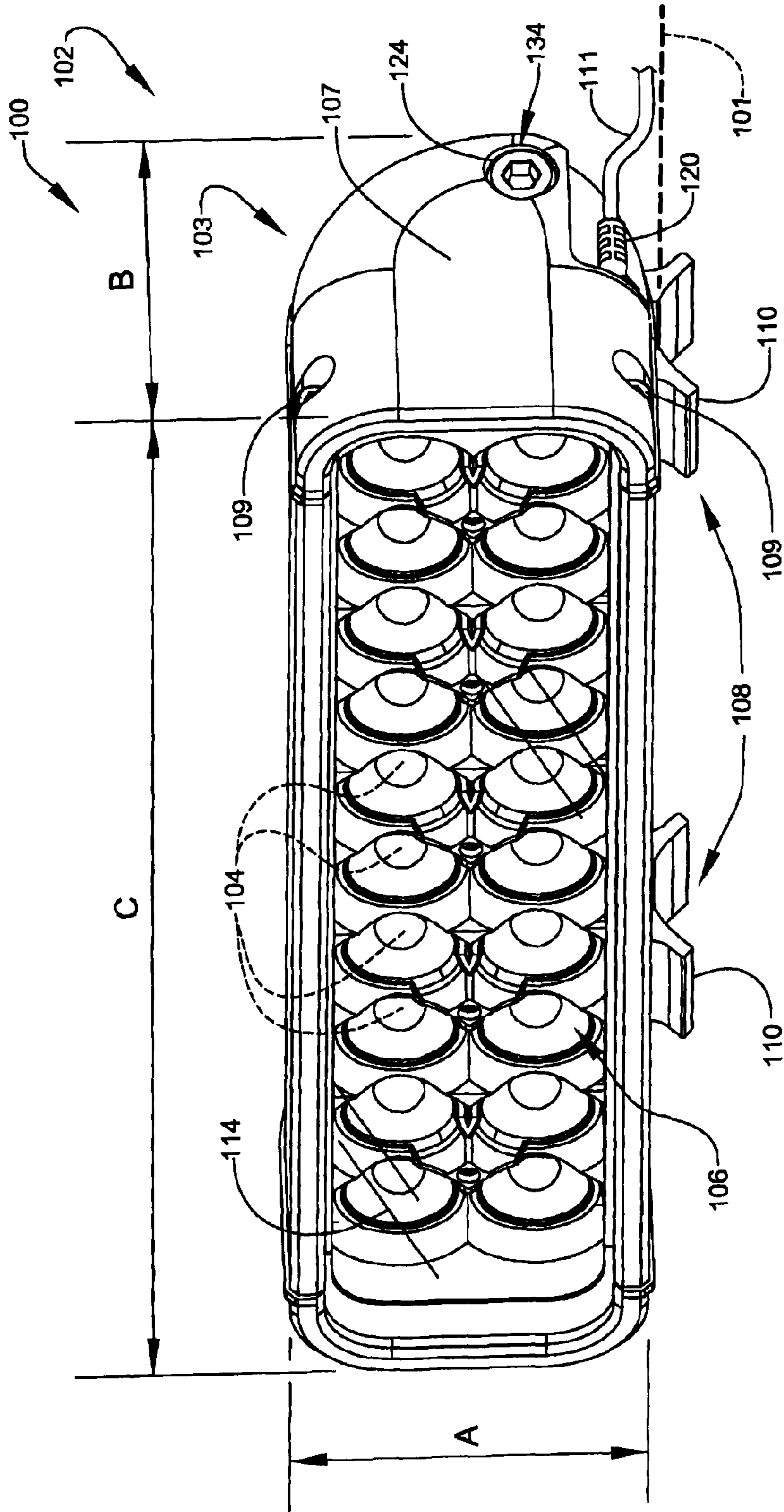

FIG. 1

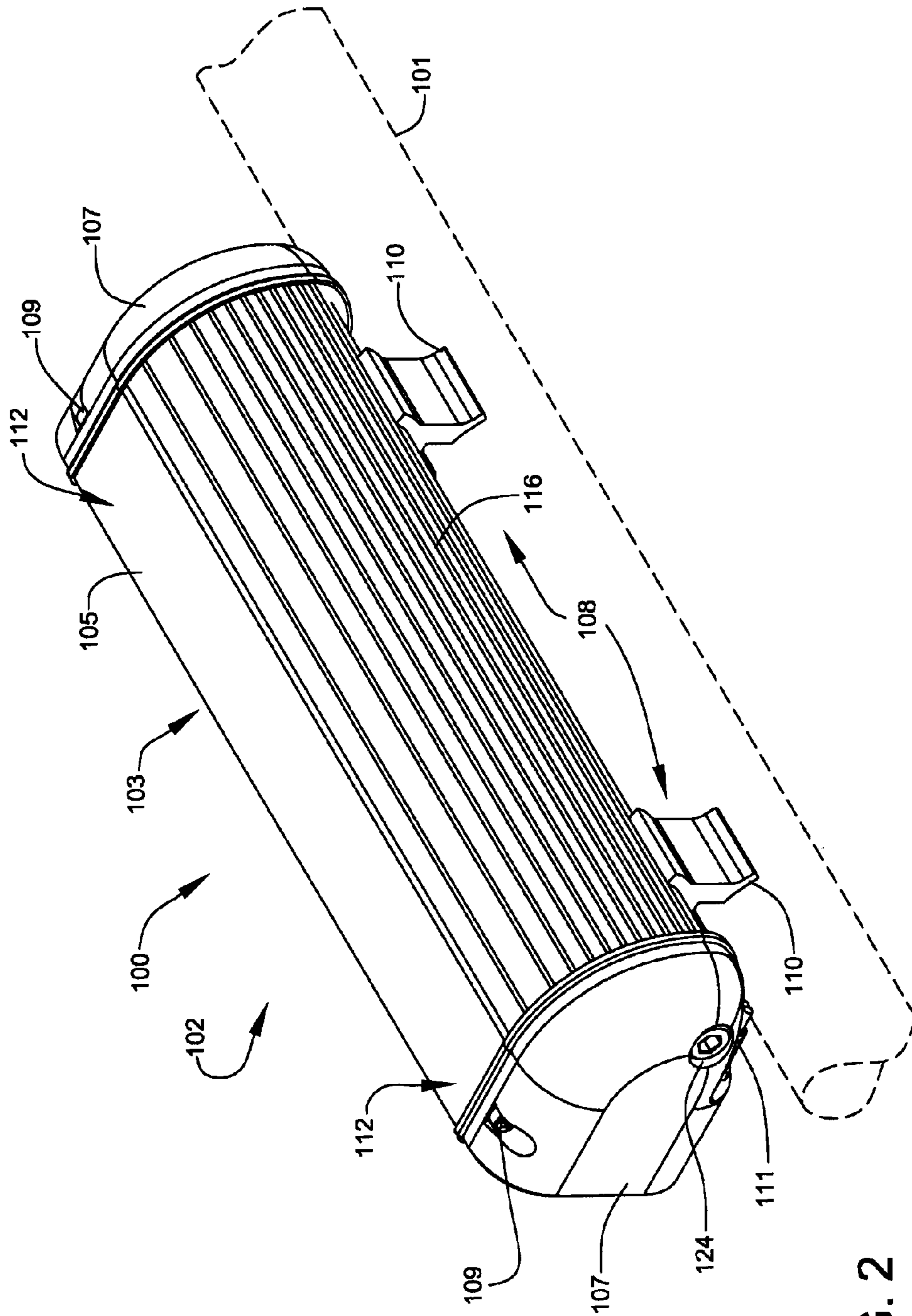

FIG. 2

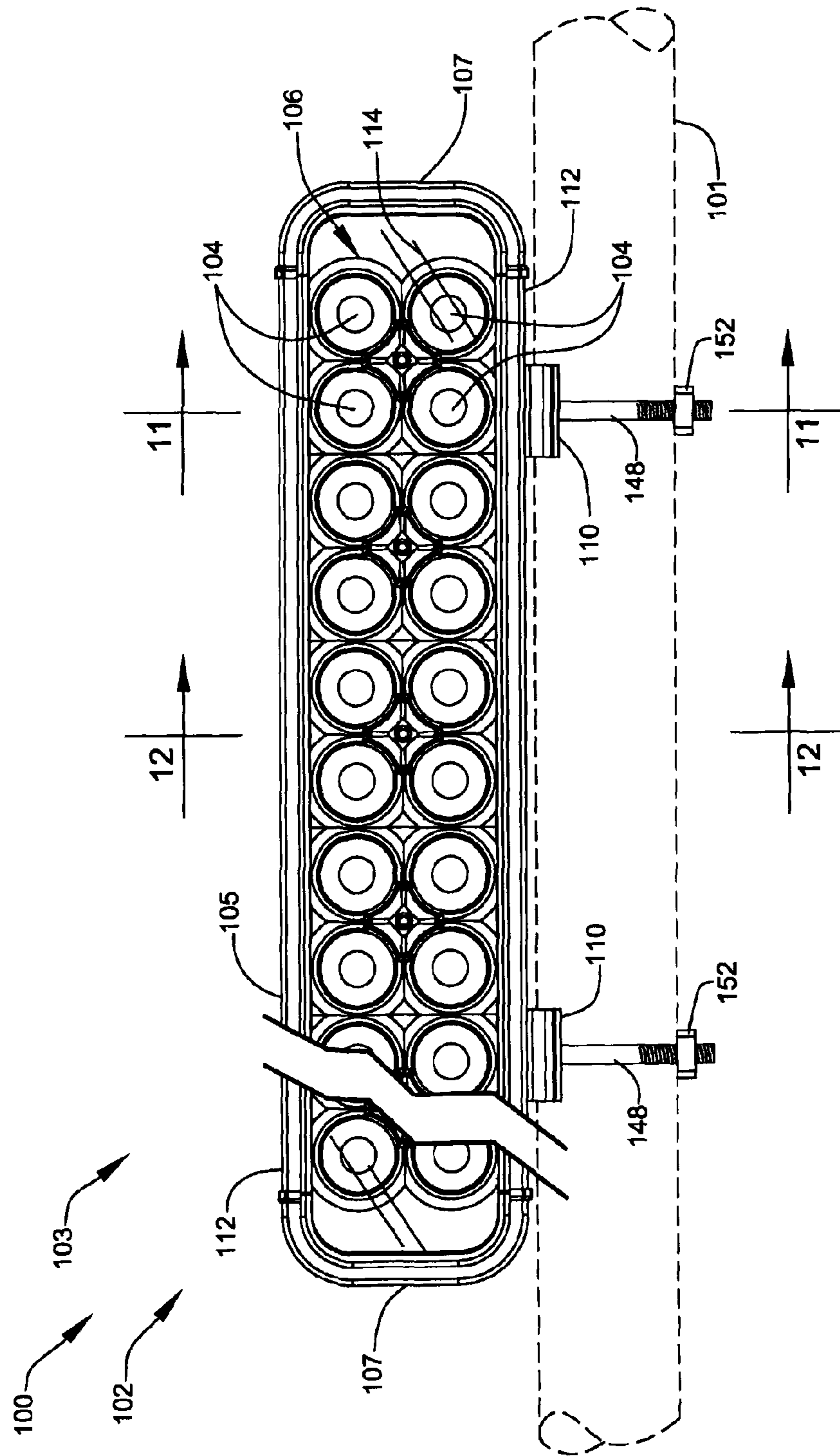

FIG. 3

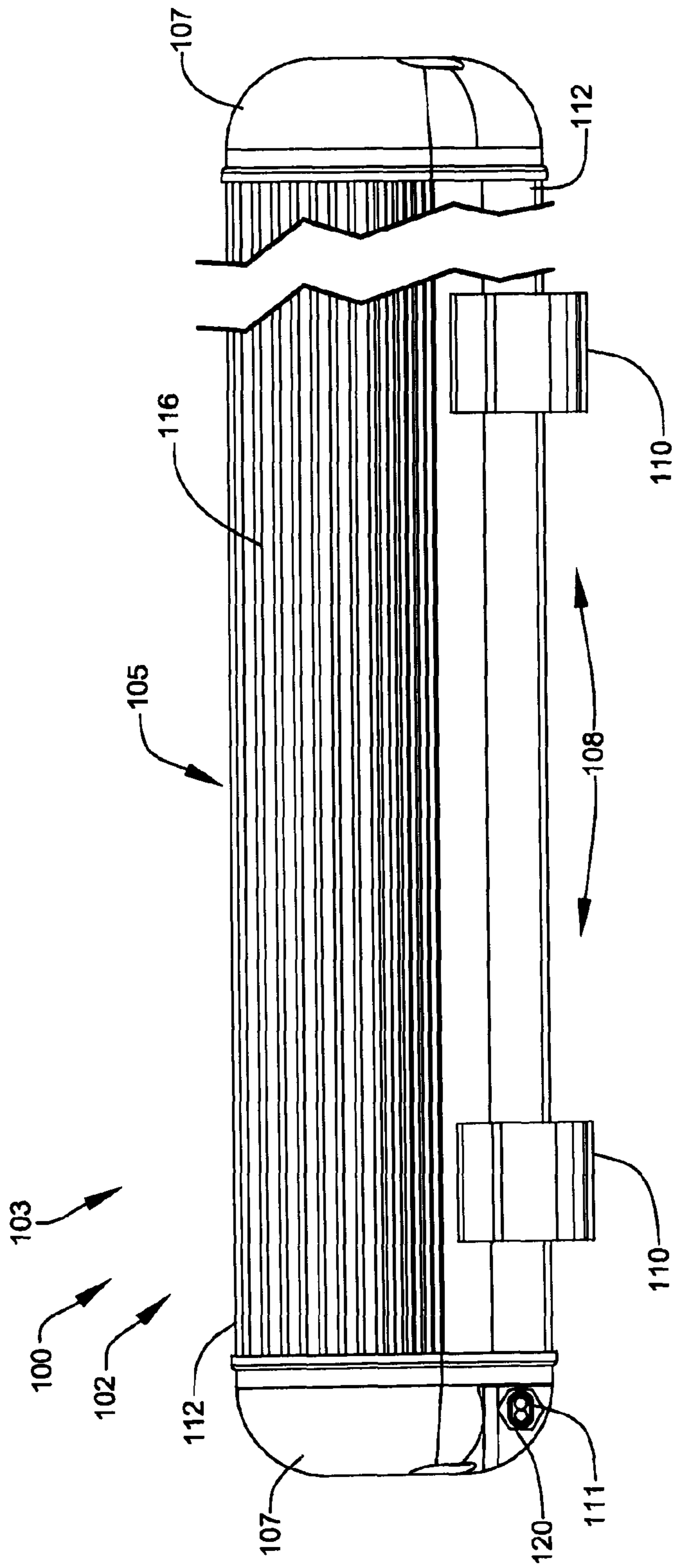

FIG. 4

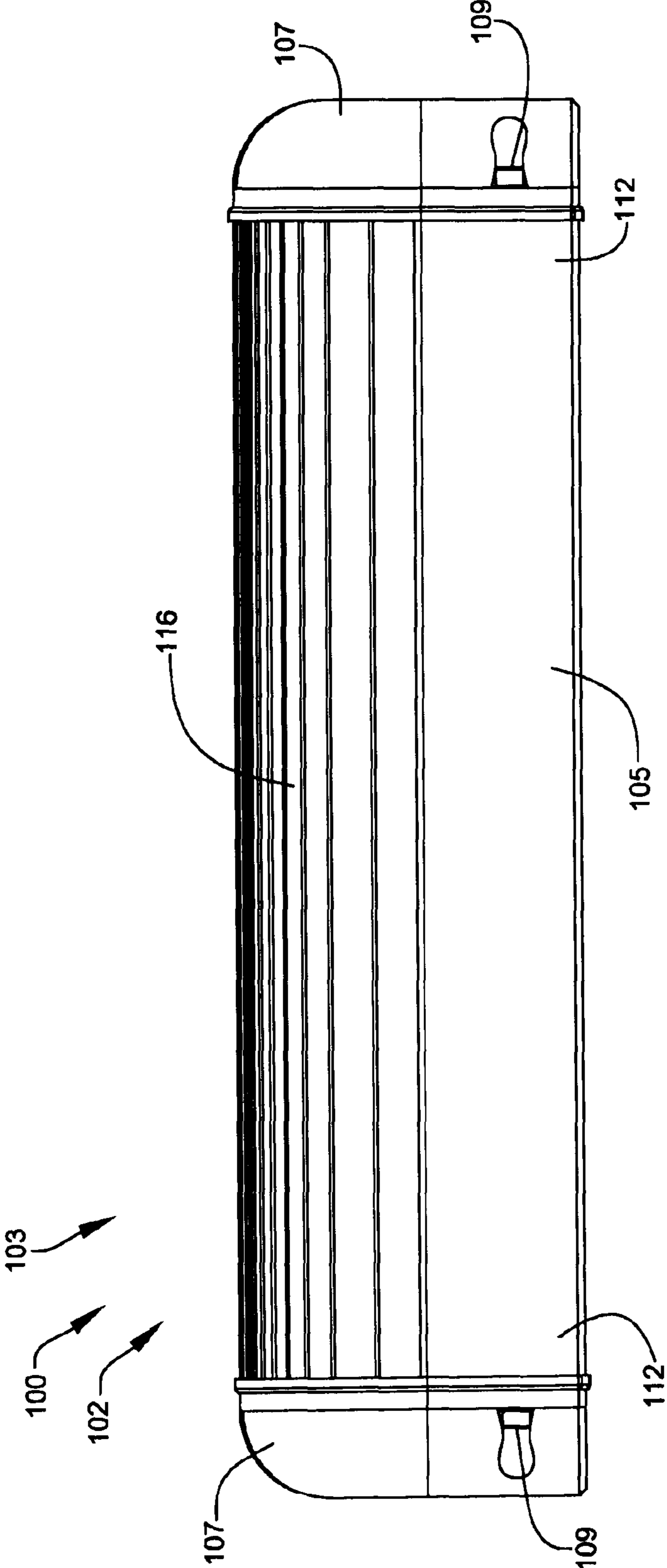

FIG. 5

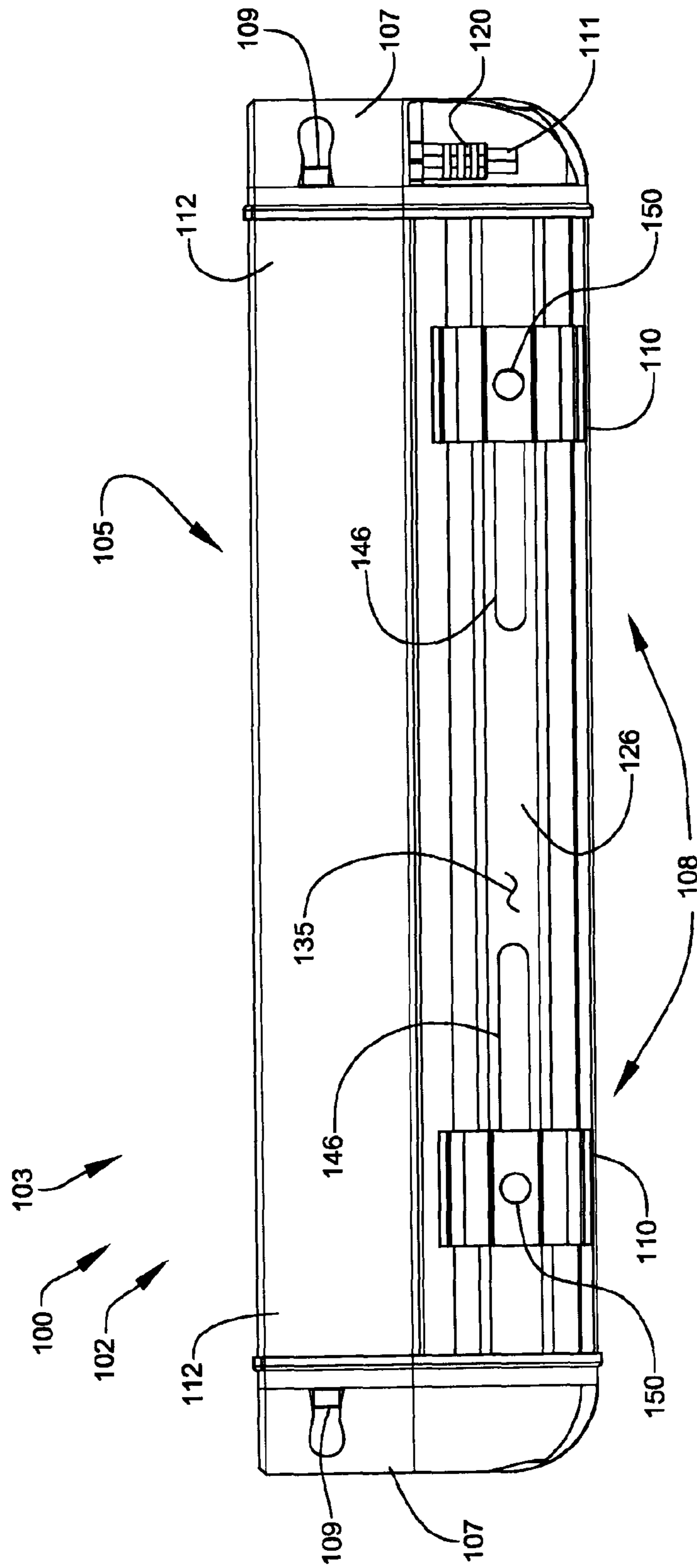

FIG. 6

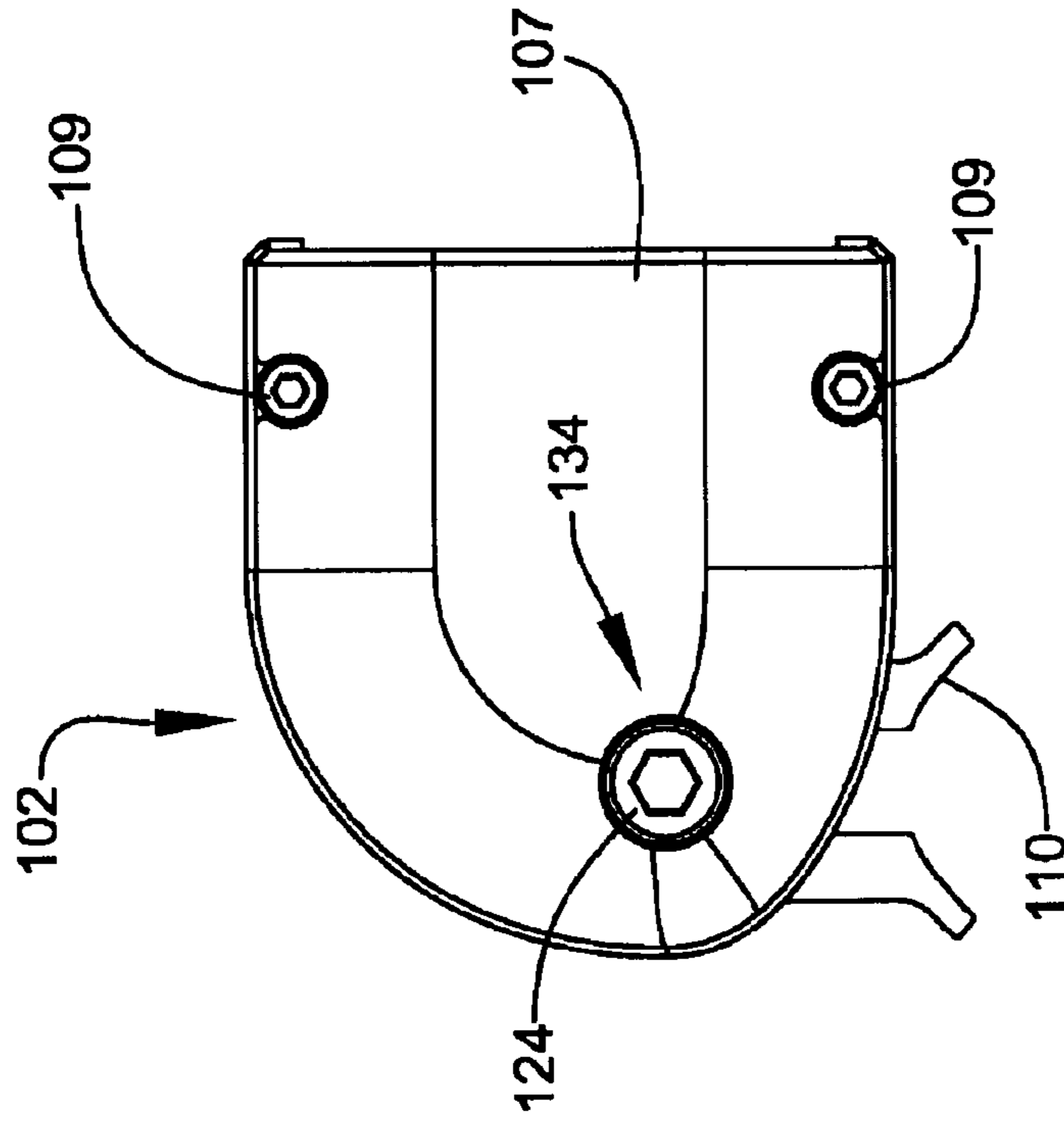

FIG. 8

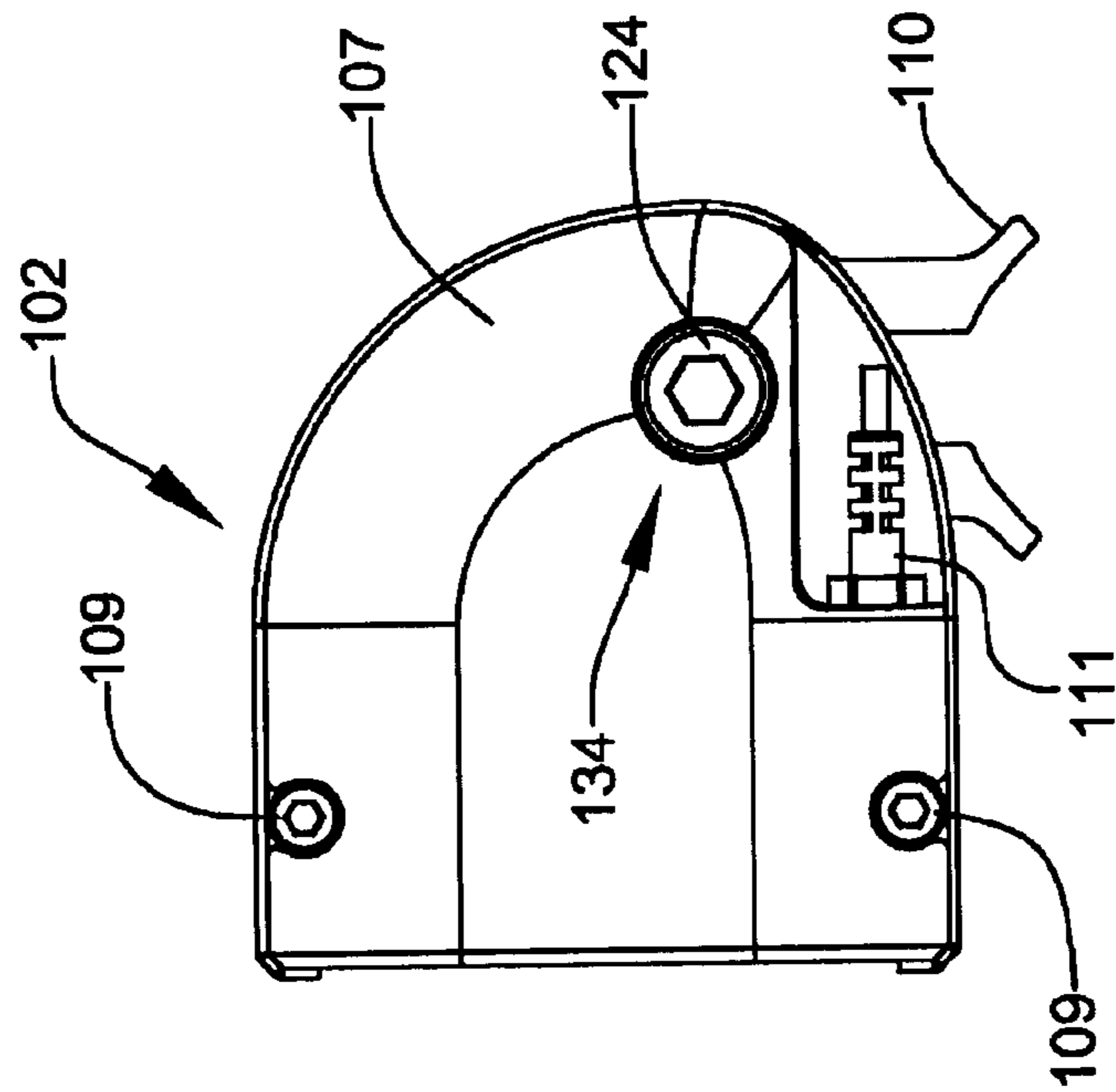

FIG. 7

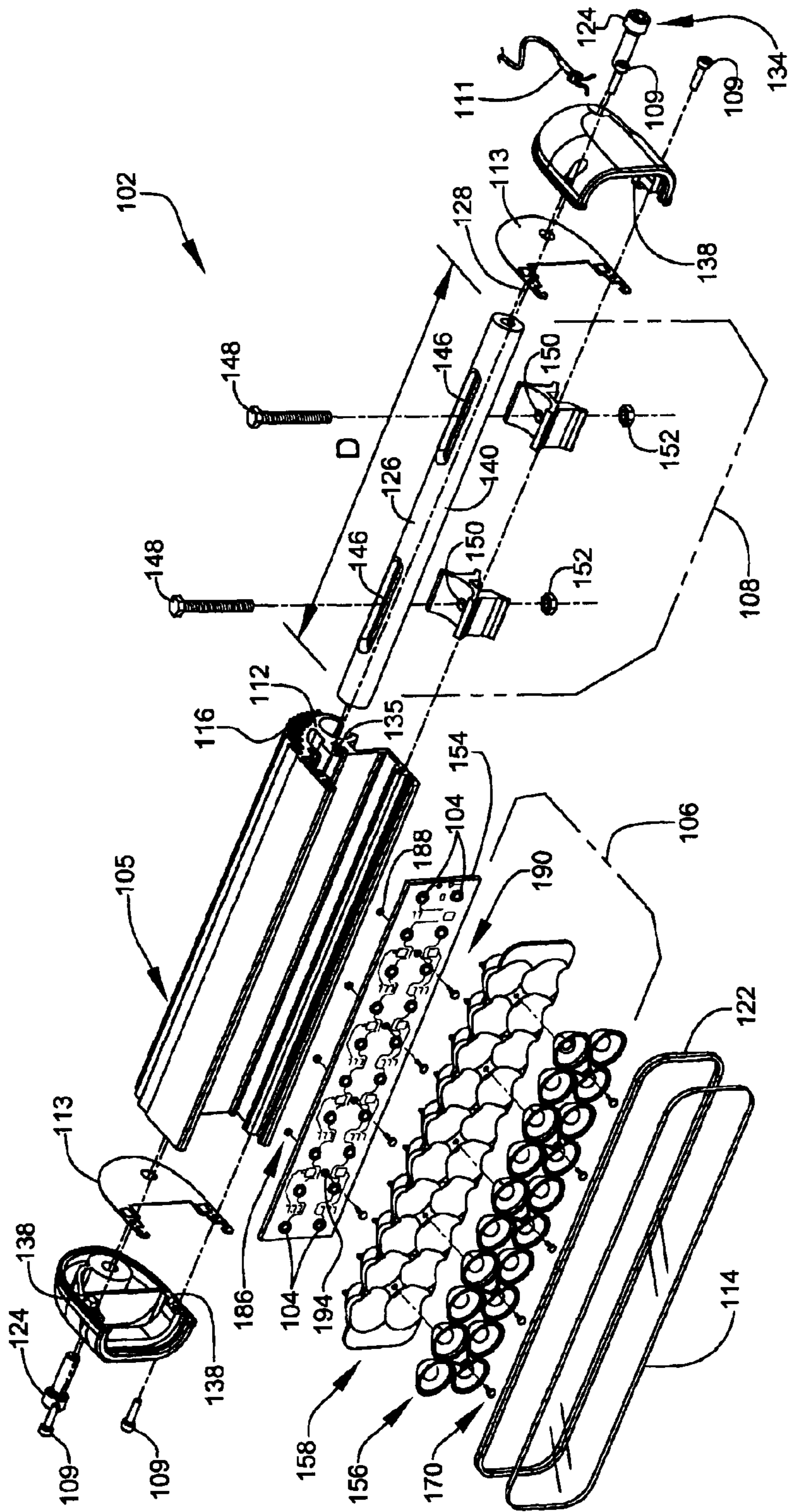

FIG. 9

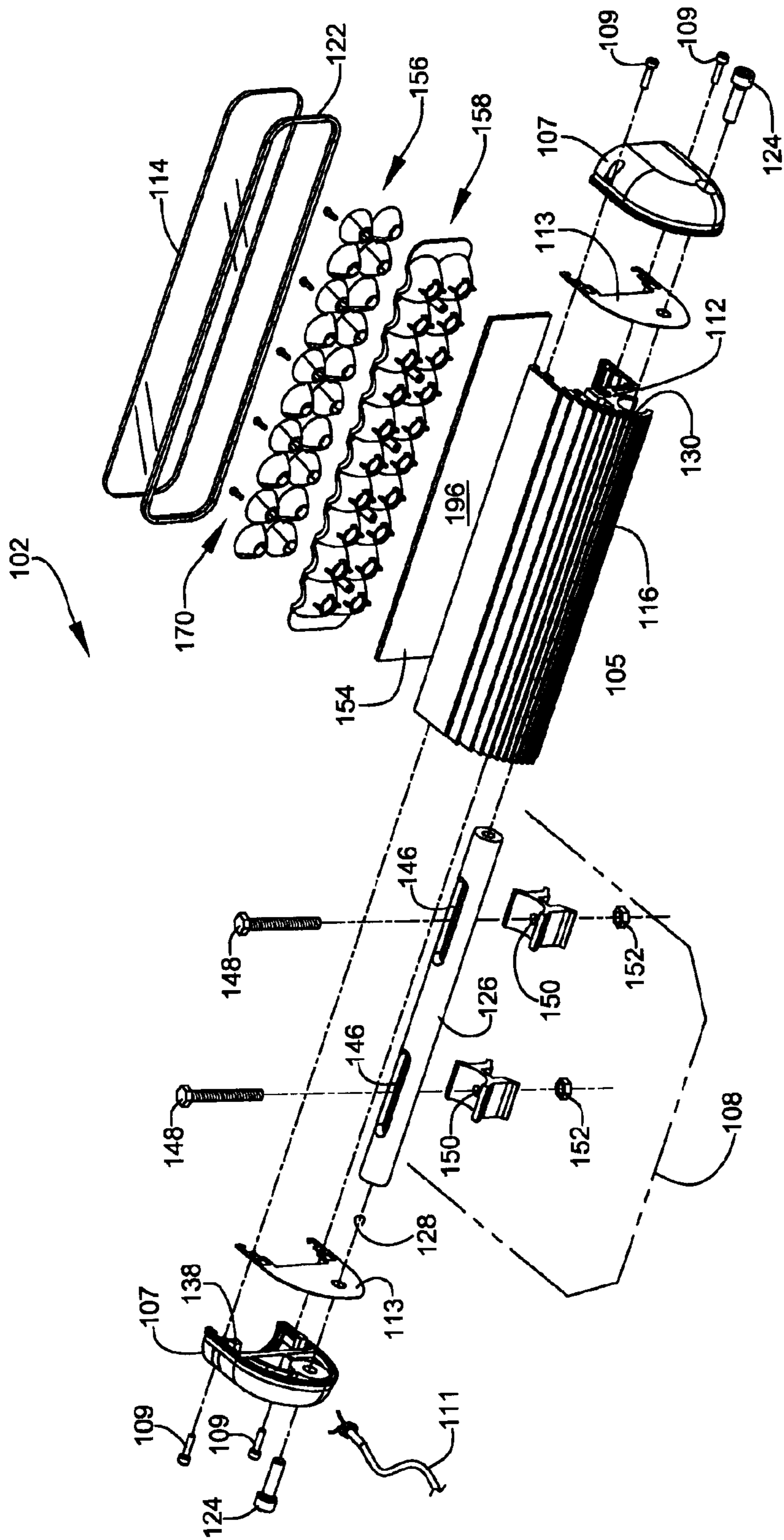

FIG. 10

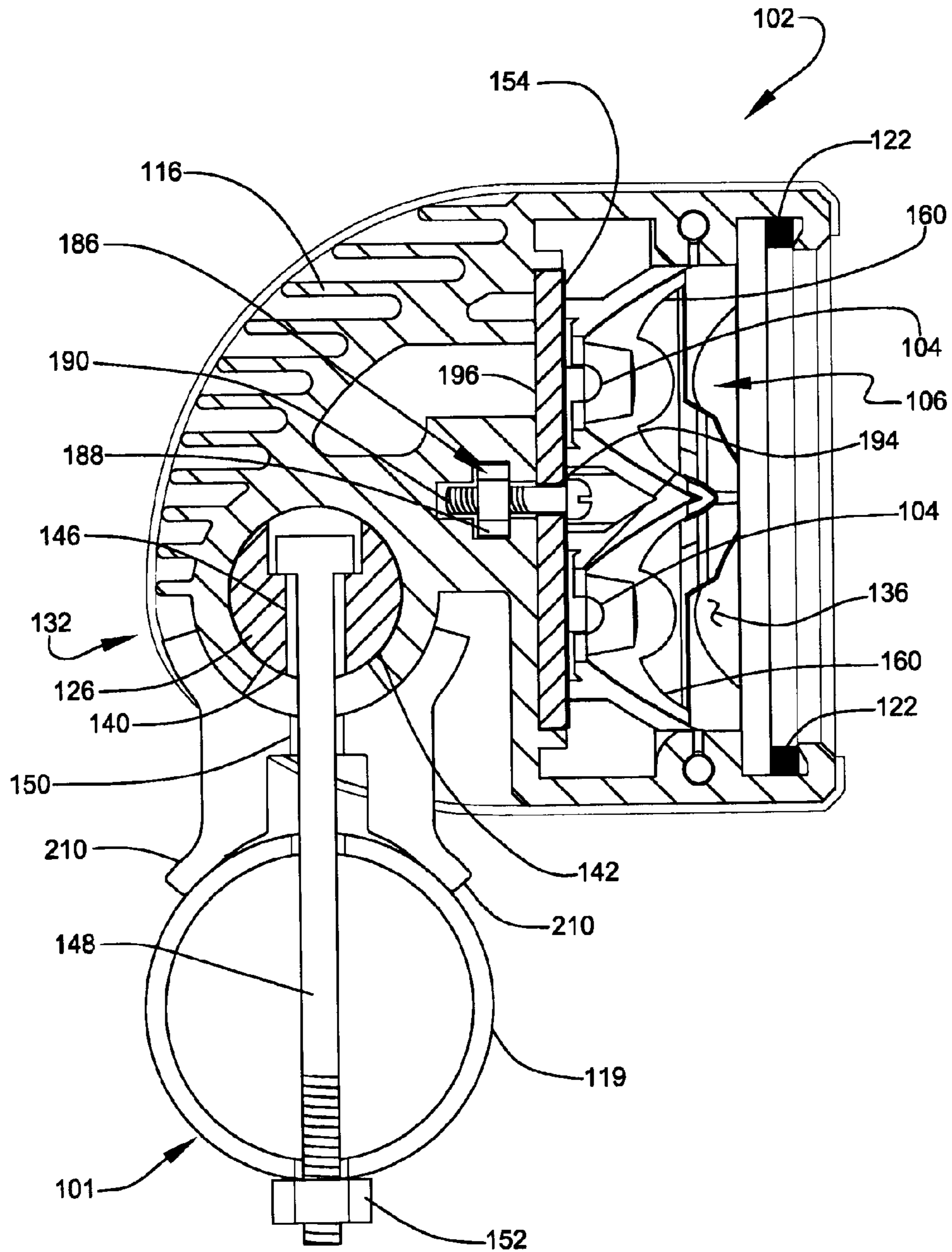

FIG. 11

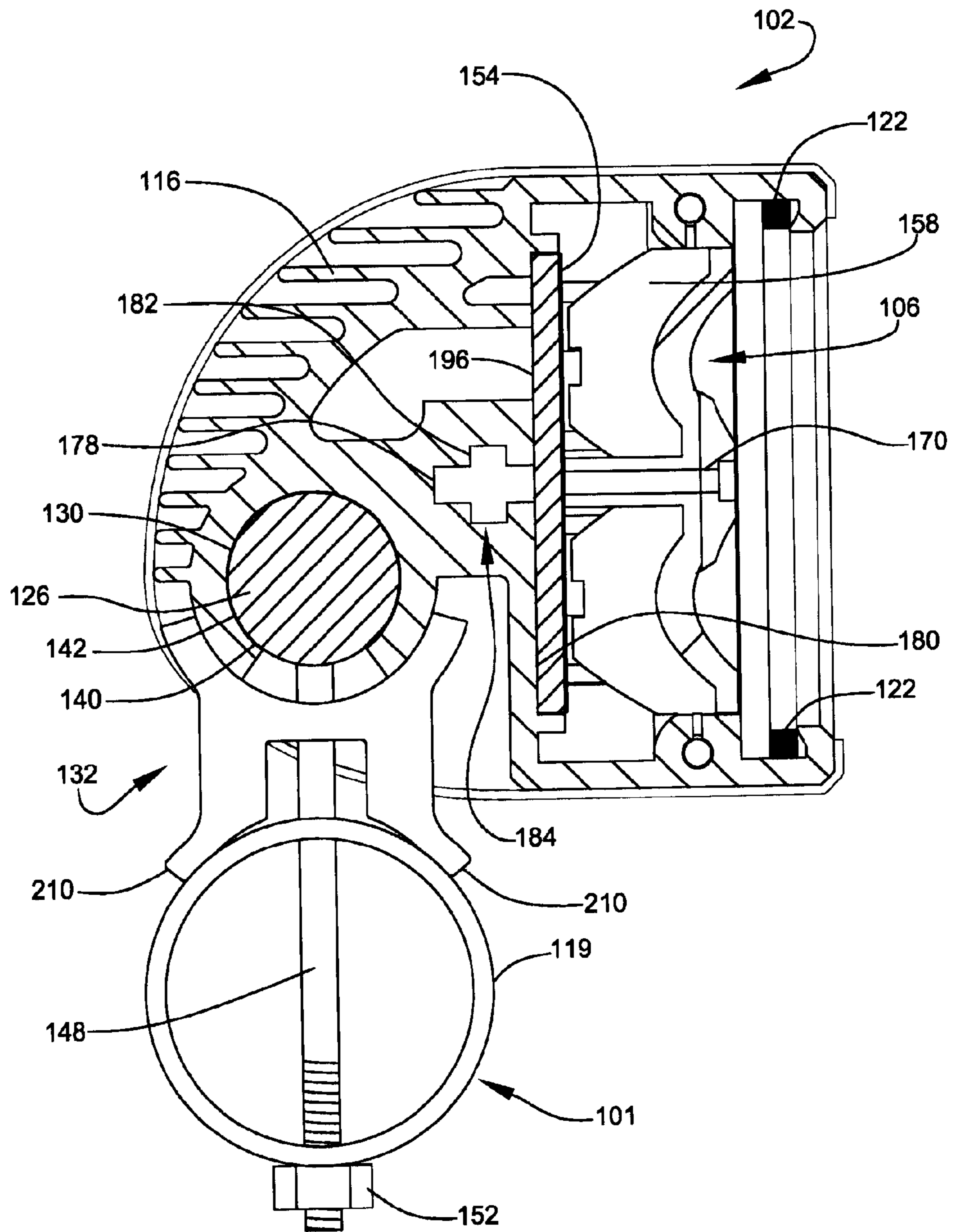

FIG. 12

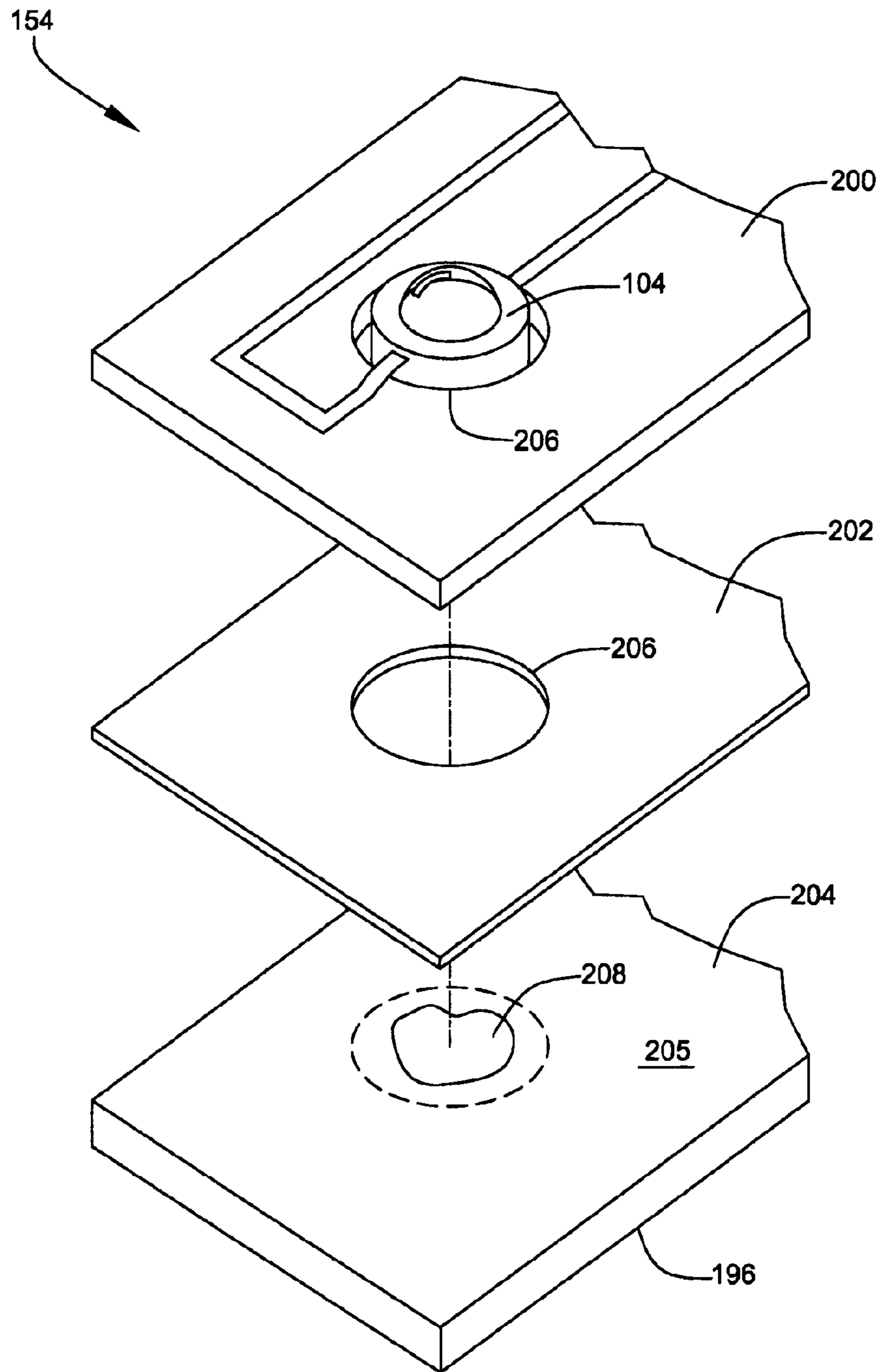

FIG. 13

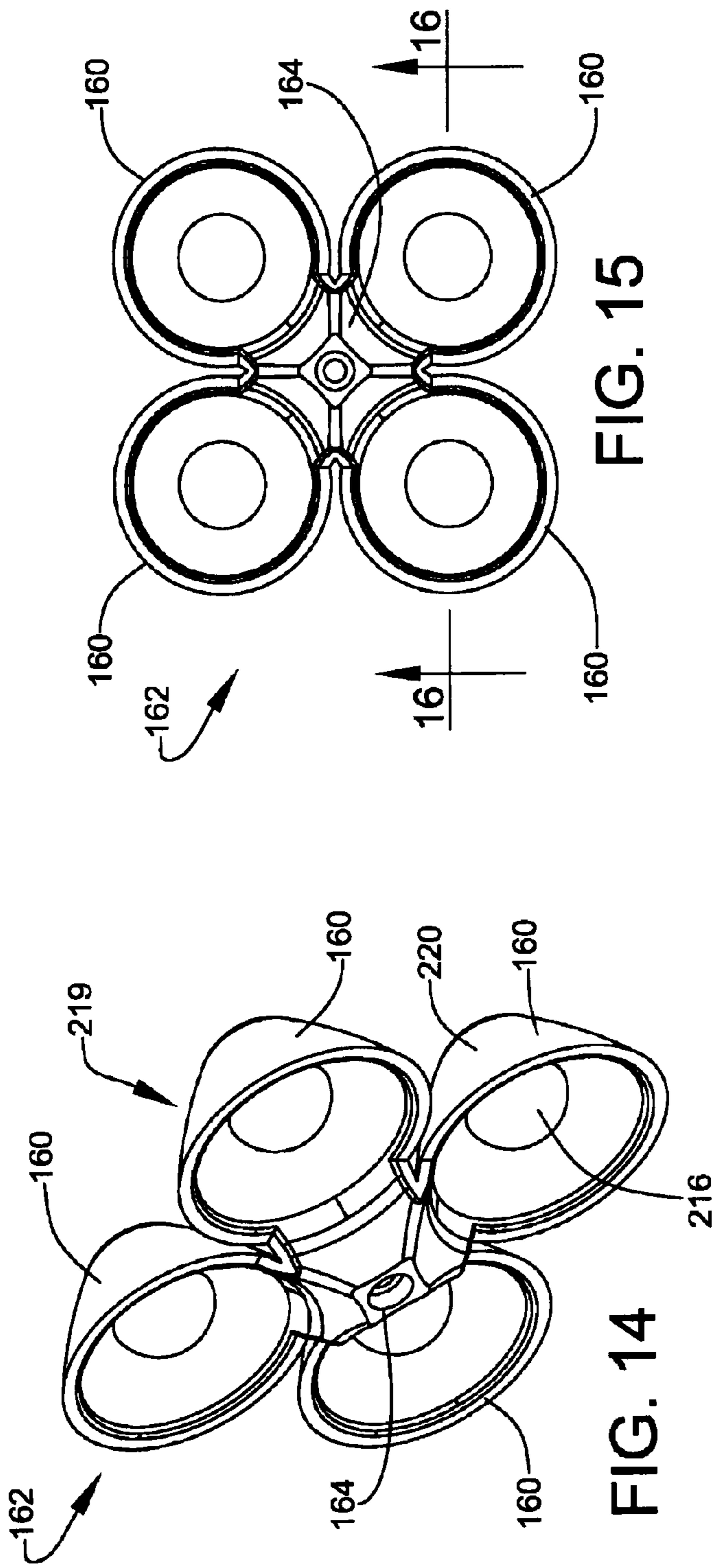

FIG. 15

FIG. 14

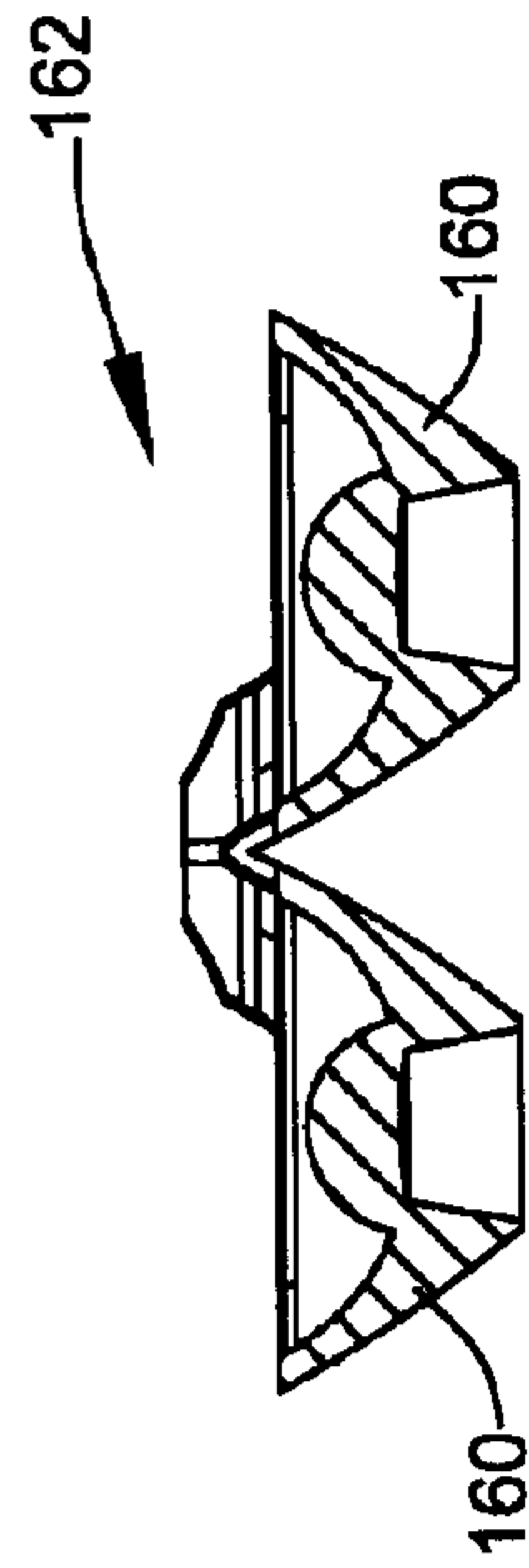

FIG. 16

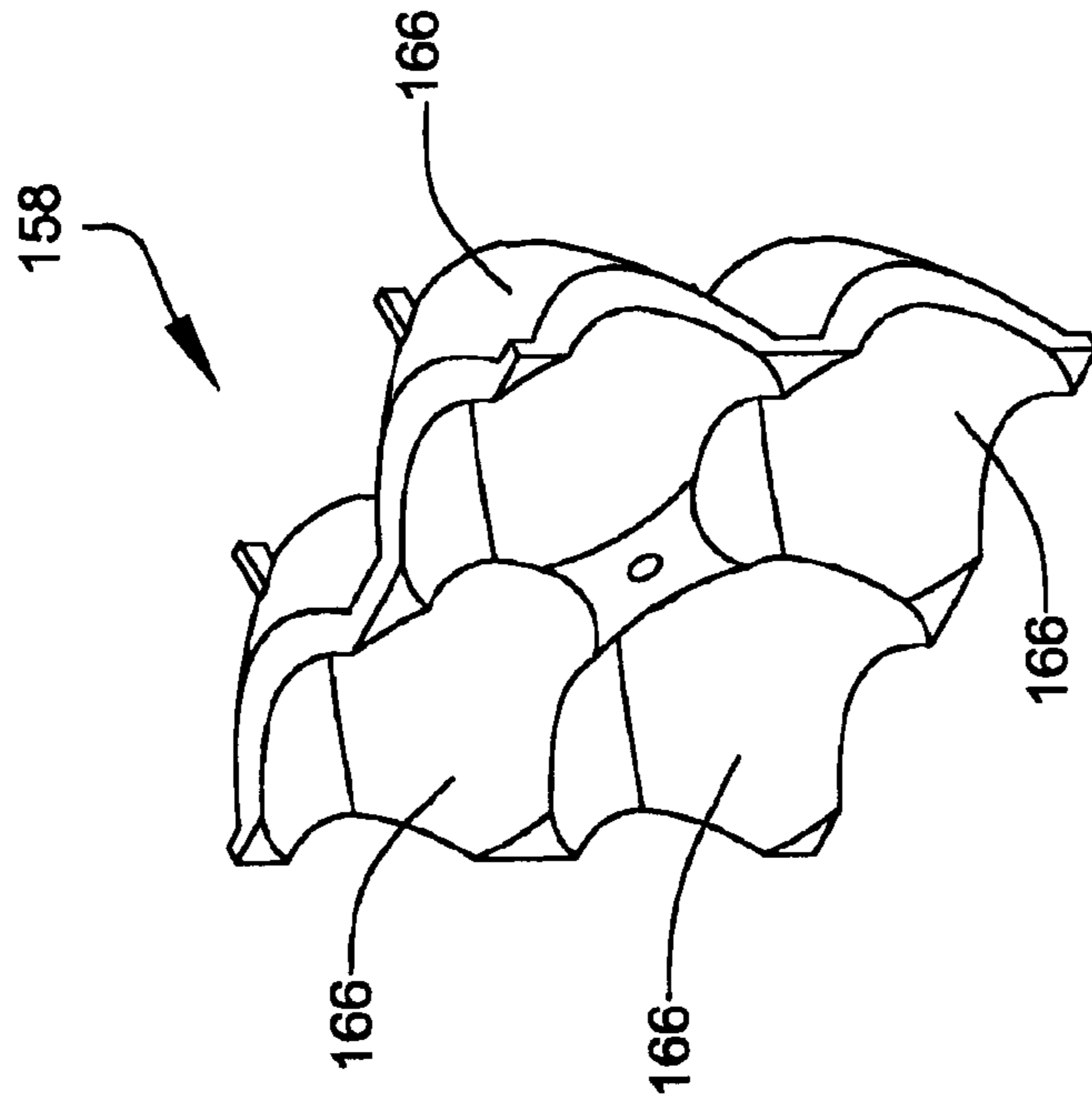

FIG. 18

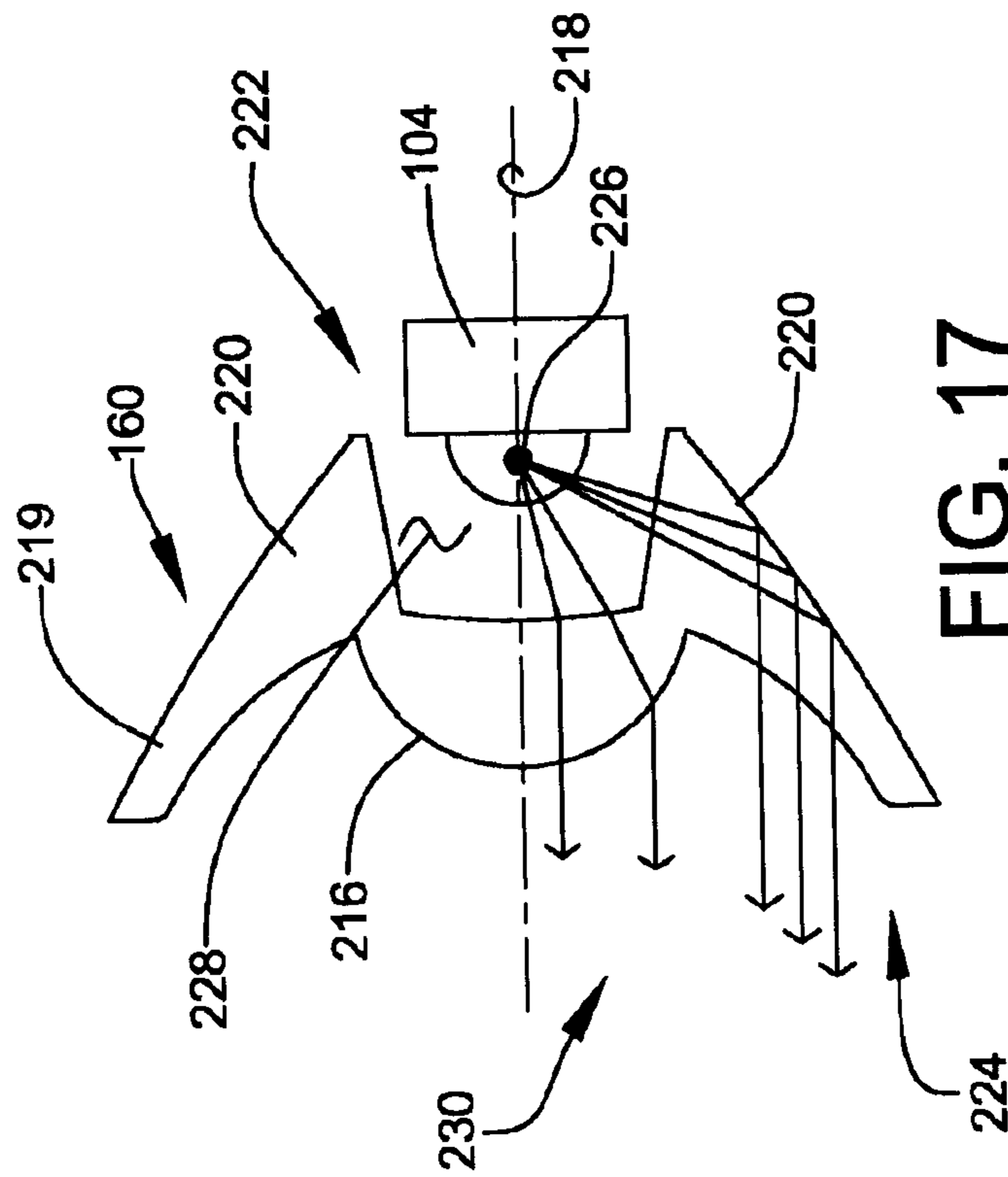

FIG. 17

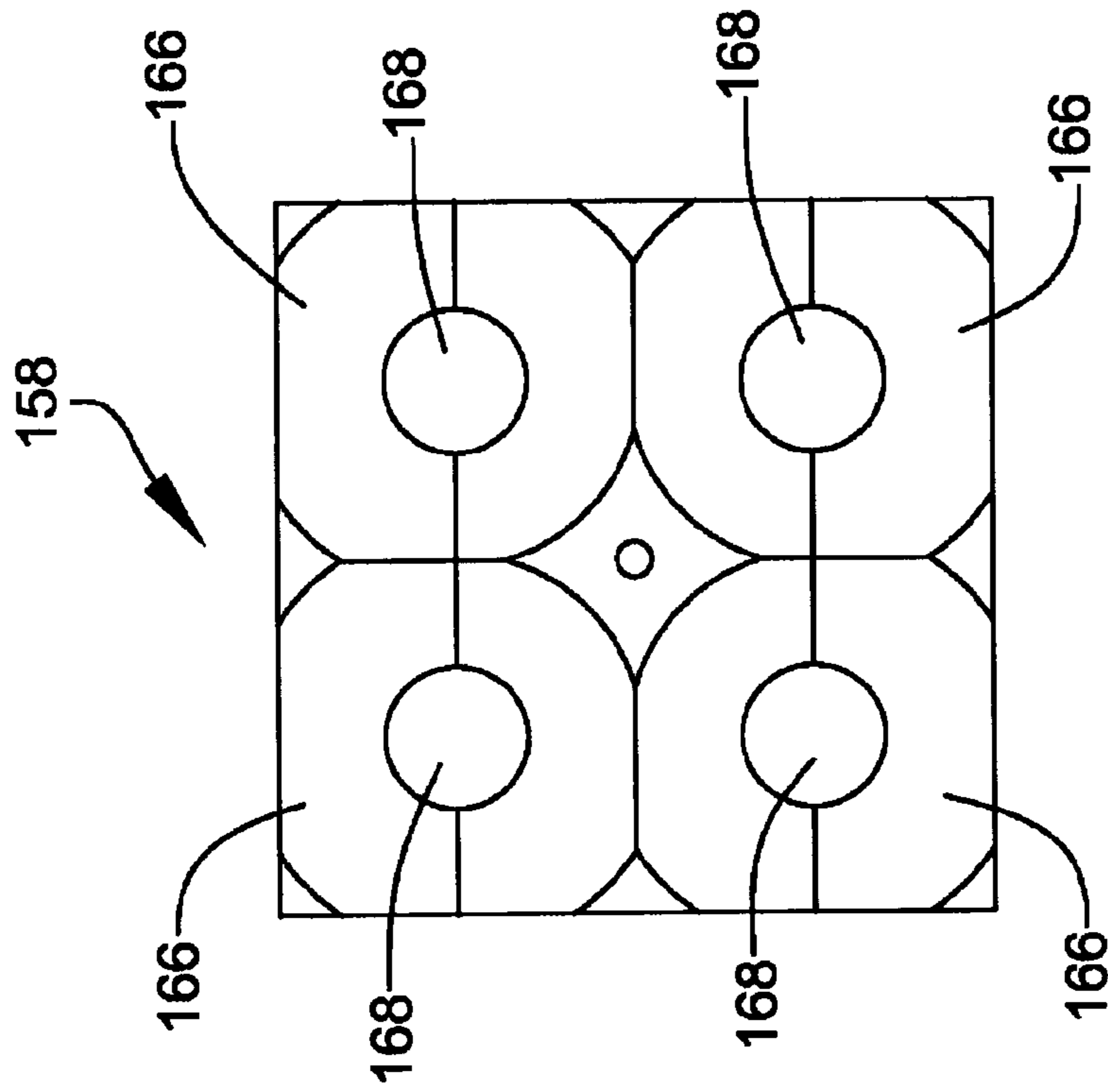

FIG. 19

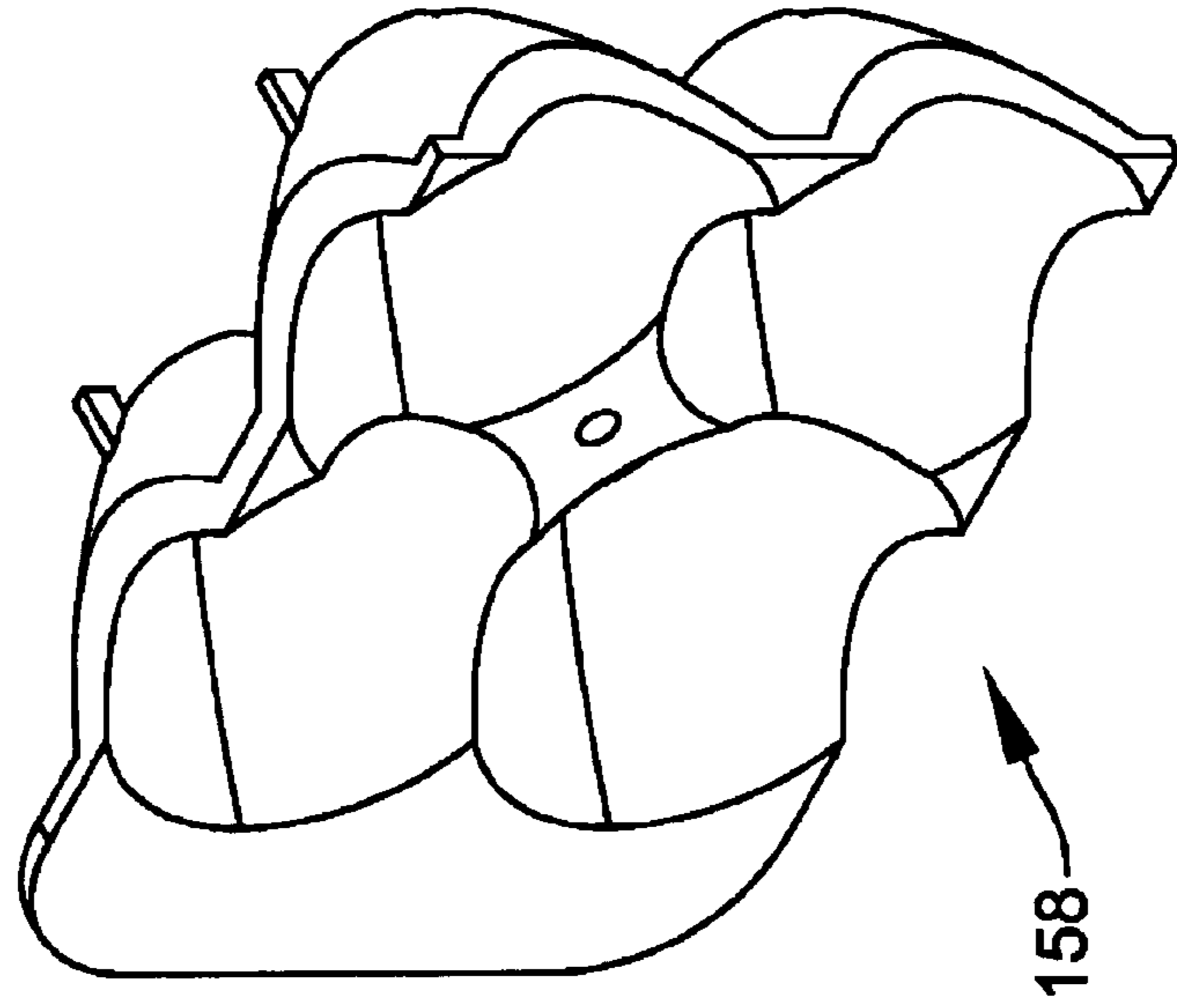

FIG. 20

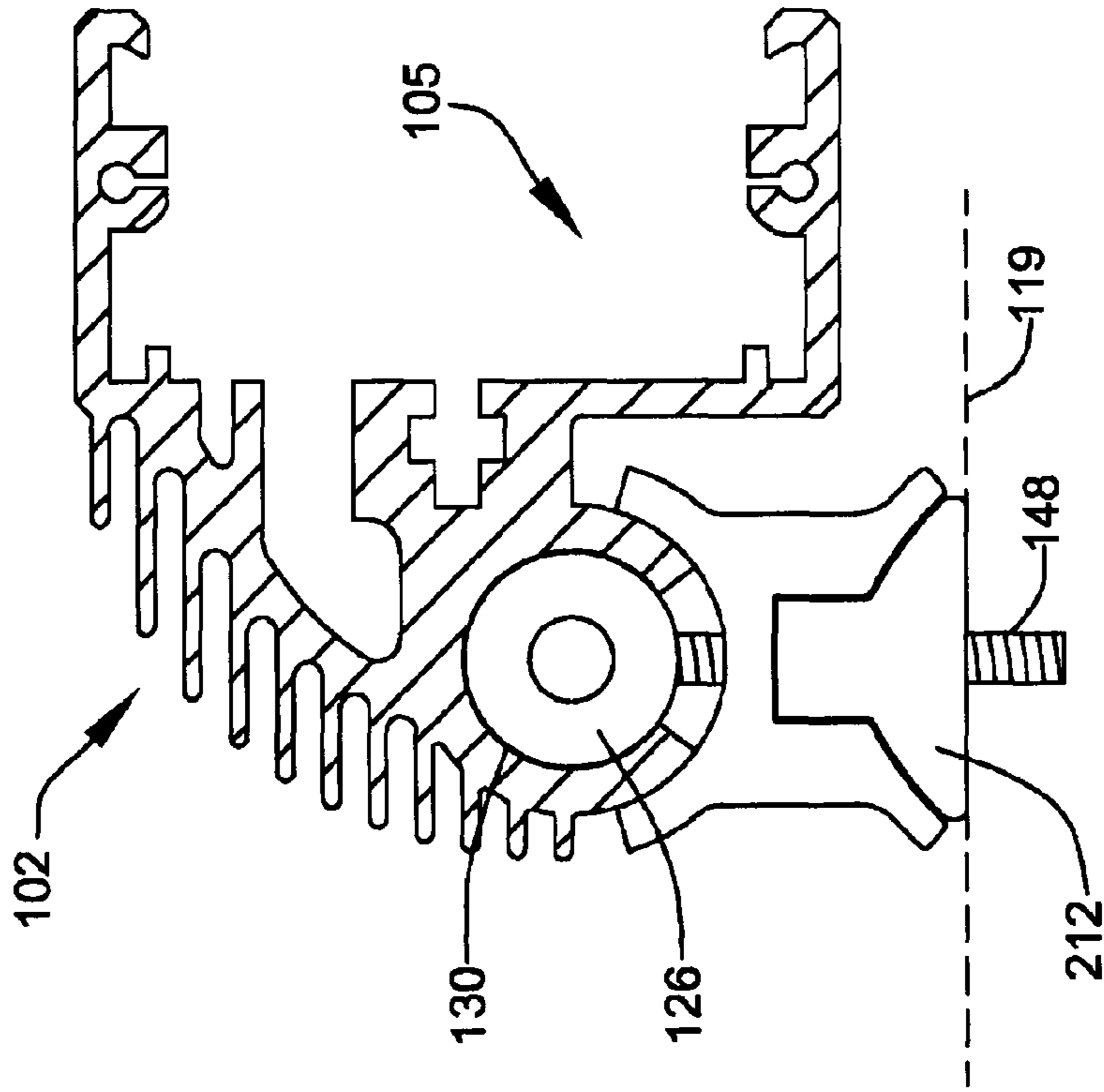

FIG. 22

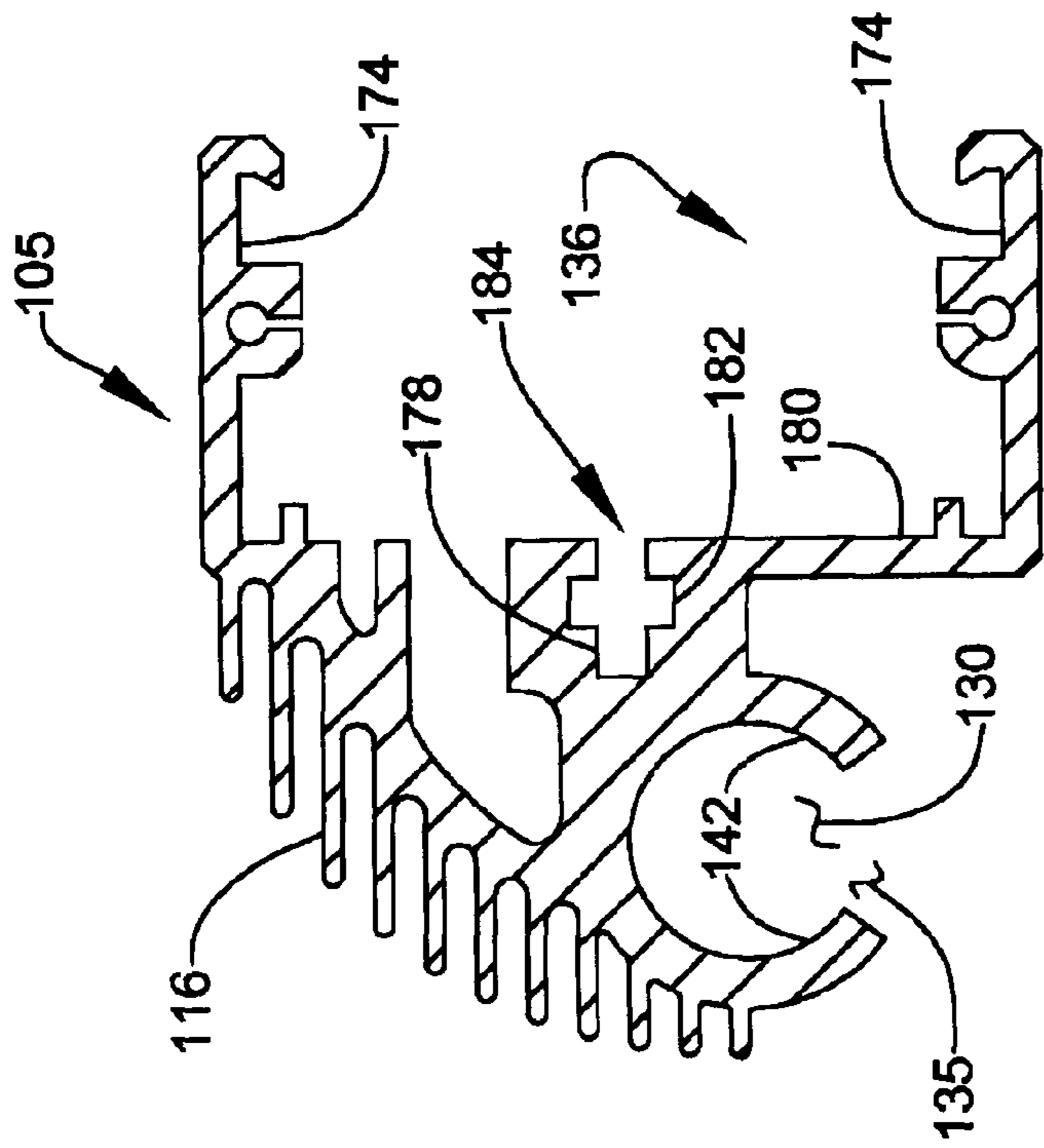
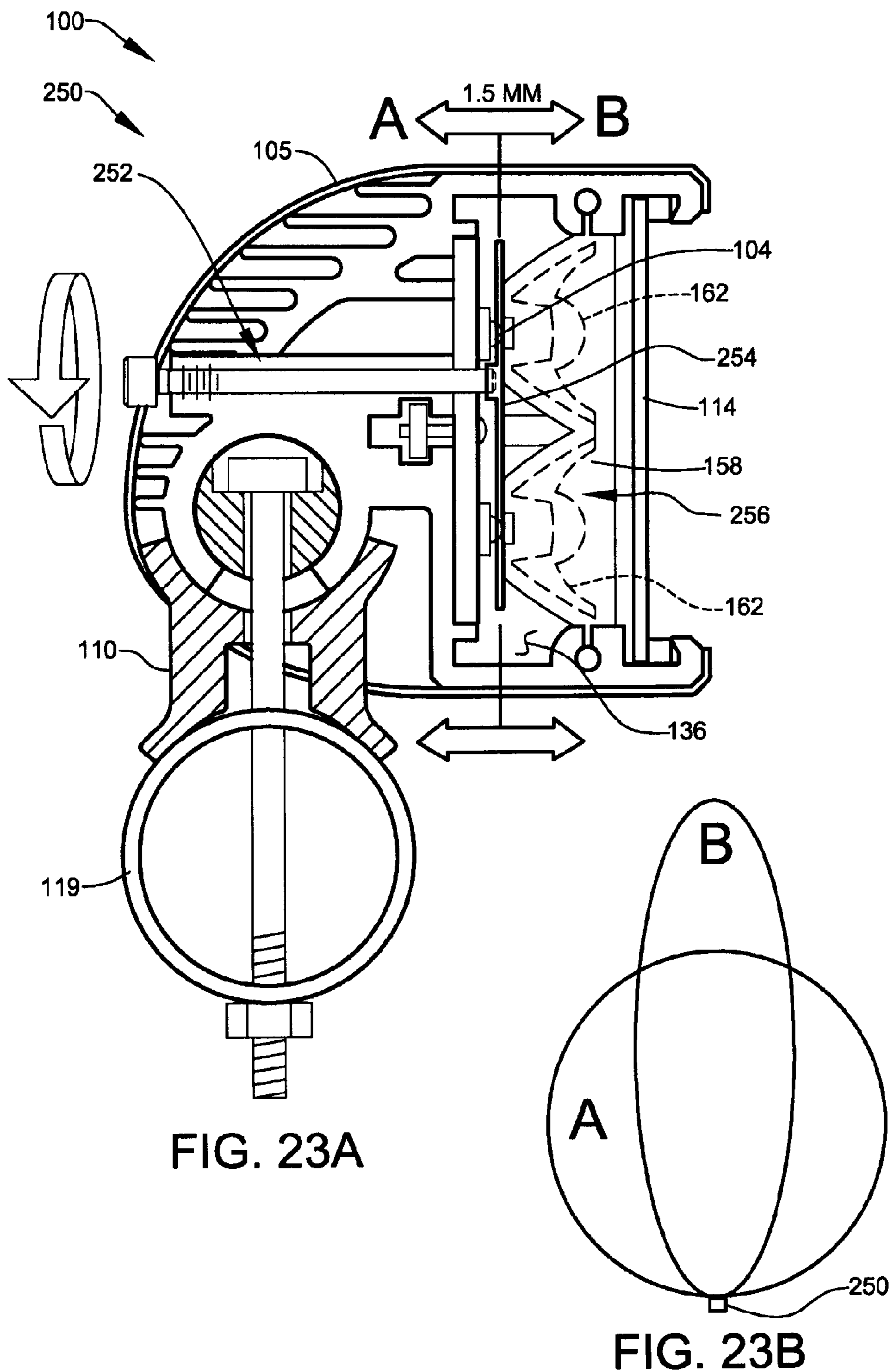

FIG. 21



AUXILIARY LIGHTING SYSTEMS

Matter enclosed in heavy brackets [] appears in the original patent but forms no part of this reissue specification; matter printed in italics indicates the additions made by reissue; a claim printed with strikethrough indicates that the claim was canceled, disclaimed, or held invalid by a prior post-patent action or proceeding.

CROSS-REFERENCE TO RELATED APPLICATION

The present application is related to and claims priority from prior provisional application Ser. No. 60/983,120, filed Oct. 26, 2007, entitled "AUXILIARY LIGHTING SYSTEMS", and is related to and claims priority from prior provisional application Ser. No. 61/060,767, filed Jun. 11, 2008, entitled "AUXILIARY LIGHTING SYSTEMS", the contents of both of which are incorporated herein by this reference and are not admitted to be prior art with respect to the present invention by the mention in this cross-reference section.

BACKGROUND

This invention relates to providing auxiliary lighting systems. More particularly, this invention relates to vehicle-mounted auxiliary lighting systems adapted to provide primary or auxiliary vehicle lighting.

Effective external lighting is important to the safe operation of vehicles in low light environments. In general, effective external vehicle lighting systems should exhibit a maximum output of useful illumination at a level of current draw within the capacity of the vehicle's electrical system, a physical size appropriate to the physical structures of the vehicle, and in-service durability consistent with the operational dynamics of the vehicle to which the system is equipped. In addition, such systems should operate consistently and on-demand with minimal care maintenance. Improving the effectiveness of such external vehicle lighting systems would be of great benefit not only within the fields of vehicular design and production, but also within fields dependent on safe and efficient vehicle operation.

OBJECTS AND FEATURES OF THE INVENTION

A primary object and feature of the present invention is to provide a system addressing the above-mentioned issues.

It is a further object and feature of the present invention to provide such a system generating relatively high levels of usable illumination at a relatively low amperage draw. It is another object and feature of the present invention to provide such a system having a high degree of in-service durability, even within applications developing high dynamic forces. It is a further object and feature of the present invention to provide such a system comprising a relatively compact and weather-resistant housing. It is another object and feature of the present invention to provide such a system having such a compact housing that may be supplied in essentially any modular length.

It is another object and feature of the present invention to provide such a system utilizing an array of light-emitting diodes (LEDs). It is a further object and feature of the present invention to provide such a system comprising an

efficient heat-rejecting arrangement adapted to reject heat developed by the light-emitting diodes during operation.

It is a further object and feature of the present invention to provide such a system comprising a mounting assembly that is both readily adjustable and highly stable during use. A further primary object and feature of the present invention is to provide such a system that is efficient, inexpensive, and handy. Other objects and features of this invention will become apparent with reference to the following descriptions.

SUMMARY OF THE INVENTION

In accordance with a preferred embodiment hereof, this invention provides a lighting system comprising: at least one linear light module structured and arranged to produce light; at least one linear housing, comprising at least one housing length, structured and arranged to house such at least one linear light module; at least one mounting assembly structured and arranged to assist mounting of such at least one linear housing to at least one mountable surface; wherein such at least one mounting assembly comprises at least one elongated support bar structured and arranged to support such at least one linear housing substantially continuously along such at least one housing length, wherein such at least one elongated support bar comprises at least one longitudinal axis and at least one bar length, moveably coupled with such at least one elongated support bar, at least one attacher structured and arranged to assist fixed attachment of such at least one elongated support bar to the at least one mountable surface, wherein such at least one attacher comprises at least one axial translator structured and arranged to assist axial translation of such at least one attacher along at least one translational axis oriented substantially parallel to such at least one longitudinal axis of such at least one elongated support bar; wherein such at least one linear housing comprises at least one internal bar-receiving channel structured and arranged to receive therein substantially an entire such bar length of such at least one elongated support bar; and wherein such at least one linear housing is structured and arranged to be rotatable about such at least one longitudinal axis when engaged within such at least one internal bar-receiving channel.

Moreover, it provides such a lighting system wherein such at least one linear housing comprises: at least one extruded member having open ends and at least one internal hollow cavity structured and arranged to house such at least one linear light module; at least one end cap structured and arranged to cap such open ends; at least one front protective cover structured and arranged to protectively cover at least one front portion of such at least one internal hollow cavity; wherein such at least one front protective cover comprises at least one substantially transparent composition structured and arranged transparently pass the light produced by such at least one linear light module therethrough. Additionally, it provides such a lighting system further comprising at least one environmental infiltrate blocker structured and arranged to block the passage of environmental infiltrates into such at least one internal hollow cavity through mated engagements of such at least one extruded member.

Also, it provides such a lighting system further comprising: situate between each such at least one end cap and each such at least one open end, at least one end seal structured and arranged to seal such at least one end cap to a respective such at least one open end; and situate between such at least one front protective cover, such at least one end cap, and such at least one extruded member, at least one front seal

3

structured and arranged to seal such at least one front protective cover to such at least one end cap and such at least one extruded member; wherein such at least one end seal and such at least one front seal assist in blocking the intrusion of environmental infiltrates to within such at least one internal hollow cavity. In addition, it provides such a lighting system wherein such at least one linear light module comprises: at least one electrically-driven light emitting diode structured and arranged to generate light; at least one focusing lens structured and arranged to focus the generated light into at least one beam pattern; and at least one lens positioner structured and arranged to position such at least one focusing lens relative to such at least one light source; wherein such at least one focusing lens produces such at least one beam pattern by total internal reflection.

And, it provides such a lighting system wherein such at least one focusing lens produces such at least one beam pattern by total internal reflection and refraction. Further, it provides such a lighting system further comprising at least one unifying frame structured and arranged to unify at least four of such at least one focusing lens into a single modular lens element. Even further, it provides such a lighting system wherein such at least one linear light module further comprises: at least one heat-dissipation assembly structured and arranged to dissipate heat generated by such at least one electrically-driven light emitting diode during production of the light; wherein such at least one heat-dissipation assembly comprises at least one circuit board structured and arranged to provide circuit-board support of such at least one electrically-driven light emitting diode, at least one thermally-conductive plate structured and arranged to absorb and dissipate the heat, and at least one positioner structured and arranged to position such at least one circuit board adjacent such at least one thermally-conductive plate; wherein such at least one circuit board comprises at least one aperture structured and arranged to pass at least one portion of such at least one electrically-driven light emitting diode therethrough; wherein such at least one electrically-driven light emitting diode is mounted to such at least one circuit board such that such at least one portion of such at least one electrically-driven light emitting diode passes through such at least one aperture passage to comprise a position of thermal contact with such at least one thermally-conductive plate.

Moreover, it provides such a lighting system wherein: such at least one thermally-conductive plate comprises at least one heat-absorption surface and at least one heat-dissipating surface; such at least one electrically-driven light emitting diode comprises at least one position of thermal contact with such at least one heat-absorption surface; and such at least one heat-dissipating surface comprises at least one position of thermal contact with such at least one extruded member; whereby the heat generated by such at least one electrically-driven light emitting diode during production of the light is dissipated by a transfer of heat energy to such at least one extruded member. Additionally, it provides such a lighting system wherein such at least one extruded member comprises: at least one external heat-rejection region structured and arranged to assist rejection of the heat from such at least one extruded member to a surrounding environment; wherein such at least one external heat-rejection region comprises a plurality of fins structured and arranged to provide increased surface area in thermal communication with the surrounding environment.

Also, it provides such a lighting system wherein such at least one mounting assembly further comprises: at least one first positional retainer structured and arranged to position-

4

ally retain such at least one linear housing in at least one fixed rotational position relative to such at least one elongated support bar; wherein such at least one first positional retainer comprises at least one adjustable biaser structured and arranged to adjustably bias at least one outer surface of such at least one elongated support bar toward at least one position of contact with at least one inner surface of such at least one internal bar-receiving channel; wherein such at least one first positional retainer assists in maintaining such at least one fixed rotational position substantially by at least one frictional interaction between such at least one outer surface of such at least one elongated support bar and such at least one inner surface of such at least one internal bar-receiving channel.

In addition, it provides such a lighting system wherein such at least one adjustable biaser comprises: at least one threaded tensioner structured and arranged to tension such at least one attacher to at least one position of contact with such at least one linear housing and such at least one outer surface of such at least one elongated support bar to the at least one position of contact with such at least one inner surface of such at least one internal bar-receiving channel; wherein such at least one elongated support bar comprises at least one elongated slot structured and arranged to allow translational movement of such at least one threaded tensioner substantially parallel with such at least one longitudinal axis; and wherein such at least one threaded tensioner is structured and arranged to pass through such at least one elongated slot during such coupling of such at least one attacher with such at least one elongated support bar.

In addition, it provides such a lighting system wherein such at least one mounting assembly further comprises: at least one second positional retainer structured and arranged to retain such at least one linear housing in at least one fixed rotational position relative to such at least one elongated support bar; wherein such at least one second positional retainer comprises at least one threaded end lock structured and arranged to positionally lock such at least one end cap in at least one fixed rotational position relative to such at least one elongated support bar. Further, it provides such a lighting system wherein such at least one end lock comprises at least one threaded coupler structured and arranged to frictionally couple such at least one end cap to such at least one elongated support bar. Even further, it provides such a lighting system further comprising at least one conformer structured and arranged to conform such at least one attacher to at least one geometric profile of the at least one mountable surface.

Moreover, it provides such a lighting system wherein such at least one conformer is structured and arranged to be attachable to at least one generally radiused profile of the at least one mountable surface. Additionally, it provides such a lighting system wherein such at least one conformer is structured and arranged to be attachable to a generally planar of the at least one mountable surface. Also, it provides such a lighting system wherein such at least one conformer comprises at least one dampener structured and arranged to dampen transmission of mechanical forces through such at least one attacher. In addition, it provides such a lighting system wherein each such at least one attacher is independently adjustable along the at least one longitudinal axis of such at least one elongated support bar.

In accordance with another preferred embodiment hereof, this invention provides a lighting system comprising: a plurality of discrete light sources each one structured and arranged to generate light; a plurality of focusing lenses, each one structured and arranged to focus the light generated

5

by each discrete light source into at least one beam pattern; at least one lens positioner structured and arranged to position such plurality of focusing lenses relative to such plurality of discrete light sources; wherein each discrete light source of such plurality of discrete light sources comprises a light-emitting diode; and wherein such each focusing lens of such plurality of focusing lenses produces such at least one beam pattern substantially by total internal reflection. And, it provides such a lighting system wherein such at least one lens positioner comprises: at least one beam-pattern adjuster structured and arranged to assist user-selectable adjustment to such at least one beam pattern; wherein such user-selectable adjustment is achieved by at least one positional adjustment of such plurality of focusing lenses relative to such plurality of discrete light sources.

In accordance with another preferred embodiment hereof, this invention provides a lighting system comprising: at least one light source structured and arranged to generate light; at least one focusing lens structured and arranged to focus the generated light into at least one beam pattern; at least one beam-pattern adjuster structured and arranged to assist user selectable adjustment to such at least one beam pattern; wherein such user selectable adjustment to such at least one beam pattern is achieved by at least one positional adjustment of such at least one focusing lens relative to such at least one light source; wherein such at least one beam adjuster is structured and arranged to adjust such at least one beam between at least one flood pattern and at least one focused beam pattern; wherein such at least one focusing lens produces at least one light beam substantially by total internal reflection. In addition, it provides each and every novel feature, element, combination, step and/or method disclosed or suggested by this patent application.

BRIEF DESCRIPTION OF THE DRAWINGS

FIG. 1 shows a perspective view illustrating a light bar assembly according to a preferred embodiment of the present invention.

FIG. 2 shows a rear perspective view, illustrating the light bar assembly, according to the preferred embodiment of FIG. 1.

FIG. 3 shows a front view, with a sectional cut to indicate variable length, illustrating the light bar assembly of FIG. 1.

FIG. 4 shows a rear view illustrating the light bar assembly of FIG. 1.

FIG. 5 shows a top view of the light bar assembly of FIG. 1.

FIG. 6 shows a bottom view of the light bar assembly of FIG. 1.

FIG. 7 shows a first-end view of the light bar assembly of FIG. 1.

FIG. 8 shows a second-end view of the light bar assembly of FIG. 1.

FIG. 9 shows a front exploded view of the light bar assembly according to the preferred embodiment of FIG. 1.

FIG. 10 shows a rear exploded view of the light bar assembly according to the preferred embodiment of FIG. 1.

FIG. 11 shows the sectional view 11-11 of FIG. 3 according to the preferred embodiment of FIG. 1.

FIG. 12 shows the sectional view 12-12 of FIG. 3 according to the preferred embodiment of FIG. 1.

FIG. 13 shows an exploded perspective view diagrammatically illustrating preferred components of a heat-dissipation assembly according to a preferred embodiment of the present invention.

6

FIG. 14 shows a perspective view of a modular lens element of the light bar assembly of FIG. 1.

FIG. 15 shows a front view of the modular lens element of FIG. 14.

FIG. 16 shows a sectional view through the section 16-16 of FIG. 15.

FIG. 17 shows a schematic sectional diagram through a single focusing lens of the modular lens element of FIG. 14.

FIG. 18 shows a perspective view of a lens positioner structured and arranged to position the modular lens element of FIG. 18 in an operable position within the light bar assembly of FIG. 1.

FIG. 19 shows a front view of a preferred modular grouping of lens positioners and modular lens elements according to the preferred embodiment of FIG. 1.

FIG. 20 shows a perspective view of an end lens positioner structured and arranged to position a modular lens element in an operable position within adjacent an end cap of the light bar assembly.

FIG. 21 shows a sectional view, through a transverse section extending through a central housing section of the light bar assembly, according to the preferred embodiment of FIG. 1.

FIG. 22 shows a sectional view through a transverse section extending through the light bar assembly showing a preferred mounting to a substantially flat mounting surface according to the preferred embodiment of FIG. 1.

FIG. 23A shows a sectional view through a transverse section extending through the light bar assembly showing a preferred beam-pattern adjuster according to an alternate embodiment of the present invention.

FIG. 23B shows a schematic diagram illustrating beam pattern adjustments responsive to user manipulation of the beam-pattern adjuster of FIG. 23A.

DETAILED DESCRIPTION OF THE BEST MODES AND PREFERRED EMBODIMENTS OF THE INVENTION

FIG. 1 shows a perspective view illustrating light bar assembly 102 according to a preferred embodiment of the present invention. Preferred embodiments of auxiliary lighting system 100, including light bar assembly 102, preferably comprise compact, rugged, and lightweight vehicle-mountable lighting units especially useful in providing forward directed externally mounted lighting.

Light bar assembly 102 preferably comprises an elongated outer housing assembly 103 having a relatively compact linear profile, as shown. The preferred outer dimensions of light bar assembly 102 comprises a top-to-bottom height A of about three inches and a front-to-back depth B of about four inches, allowing the assembly to be mounted inside spaces of a vehicle that standard or traditional lights would not fit. This preferred physical format assist in adapting the system to a wide range of vehicle platforms.

Preferably, outer housing assembly 103 utilizes a modular design allowing the development of variable embodiment lengths, preferably comprising a minimum length C of about four inches, preferably extending incrementally upward to lengths C limited only by the physical size and electrical capacity of the vehicle to which the system is mounted. Preferred system lengths include 4, 6, 8, 12, 16, 22, 32, 42 and 52-inch lengths.

Preferably, light bar assembly 102 comprises an internal light-generating component identified herein as linear light module 106. Linear light module 106 preferably comprises many compact light-generating elements, preferably orga-

nized in an elongated geometric assembly, as shown, rather than utilizing a single large light-generating element as found in conventional vehicle lamps.

The preferred light-producing elements of linear light module **106** preferably comprise electrically driven light emitting diodes (hereinafter referred to as LEDs **104**). LEDs **104** are most preferred for their compact size, in-service durability, low power consumption, instantaneous response, and relatively high light output. In the frontal views of FIG. **1** and FIG. **3**, the locations of the multiple LEDs **104** of linear light module **106** are visible through the substantially transparent front protective cover **114**. Preferably, linear light module **106** is protectively sealed within outer housing assembly **103**, as shown (at least embodying herein at least one linear housing, comprising at least one housing length, structured and arranged to house such at least one linear light module). The following figures illustrate and describe preferred outer physical features and arrangements of outer housing assembly **103**.

FIG. **2** shows a rear perspective view, illustrating outer housing assembly **103**, according to the preferred embodiment of FIG. **1**. FIG. **3** shows a front view illustrating preferred external arrangements of outer housing assembly **103** of FIG. **1** (the sectional cuts within the figures indicating variable housing length). FIG. **4** shows a rear view illustrating preferred rear external configurations of outer housing assembly **103**. FIG. **5** shows a top view of outer housing assembly **103**. FIG. **6** shows a bottom view of the outer housing assembly **103** of FIG. **1**. FIG. **7** shows a first-end view of outer housing assembly **103** and FIG. **8** shows a second-end view of outer housing assembly **103**. Reference is now made to FIG. **2** through FIG. **8** with continued reference to FIG. **1**.

Outer housing assembly **103** preferably functions as a rigid weather-tight enclosure to protectively support the internal components of light bar assembly **102**. Preferably, outer housing assembly **103** comprises central housing section **105**, end caps **107**, and mounting assembly **108**, as shown.

Mounting assembly **108** preferably assists in the mounting of outer housing assembly **103** to a mountable surface of an underlying vehicle (e.g., rollover bars, light bars, bumper bars, a cab surface, etc.). Preferably, mounting assembly **108** (at least embodying herein at least one mounting assembly structured and arranged to assist mounting of such at least one linear housing to at least one mountable surface) includes two or more attachment legs **110** used to firmly attach outer housing assembly **103** to vehicle **101** (at least embodying herein at least one attacher). Preferably, attachment legs **110** are spaced at regular intervals along the length of outer housing assembly **103**, as shown. Preferably, each attachment leg **110** extends outwardly from mounting assembly **108**, as shown, to elevate outer housing assembly **103** away from the underlying vehicle **101**. Preferably, to facilitate the mounting of outer housing assembly **103** to a wide range of vehicle configurations, each attachment leg **110** is positionally adjustable along the length of outer housing assembly **103**, as further described below (at least embodying herein, moveably coupled with such at least one elongated support bar, at least one attacher structured and arranged to assist fixed attachment of such at least one elongated support bar to the at least one mountable surface).

Central housing section **105** preferably comprises an elongated, channel-shaped member having opposing open end portions **112** each capped respective by end caps **107**, as shown. Central housing section **105** preferably comprises an aluminum extrusion cut to a length selected to coincide with

the preferred modular-based dimension scheme of auxiliary lighting system **100**. Most preferably, the system's modular length unit is based on a two-inch module. Upon reading the teachings of this specification, those of ordinary skill in the art will now understand that, under appropriate circumstances, considering such issues as intended use, system of measurement, component selection, etc., other modular arrangements, such as utilizing alternate modular dimensional unit (metric units), etc., may suffice.

Preferably, each end cap **107** is firmly joined to its respective end portion **112** using semi-permanent fasteners, more preferably mechanical fasteners, most preferably a plurality of threaded fasteners **109**, as shown. Preferably, to block the intrusion of water, dust, and other environmental infiltrates into outer housing assembly **103**, at least one side gasket **113** (see FIG. **9**) is placed between the interface of each end portion **112** and respective end cap **107** during assembly.

Prominently visible in the frontal views of light bar assembly **102** is front protective cover **114**, as shown, occupying substantially the entire frontal region of outer housing assembly **103**. Preferably, front protective cover **114** comprises a substantially transparent composition enabling the outward passage of light produced by the underlying linear light module **106**. Preferably, front protective cover **114** is retained within outer housing assembly **103** by engagement with central housing section **105** and both end cap **107**, as further described below.

Heat generated by LEDs **104** during operation is rejected to the surrounding environment primarily through an heat-dissipating fins **116** located on the rear portion of central housing section **105**, as best shown in the rear views of FIG. **2** and FIG. **4**. Preferably, heat-dissipating fins **116** are integrally formed within the extruded profile of central housing section **105** and function to increase the heat-dissipation the overall heat-rejecting surface area of central housing section **105** (at least embodying herein at least one at least one external heat-rejection region structured and arranged to assist rejection of the heat from such at least one extruded member to a surrounding environment, wherein such at least one external heat-rejection region comprises a plurality of fins structured and arranged to provide increased surface area in thermal communication with the surrounding environment).

Electrical power to energize light bar assembly **102** is preferably routed to linear light module **106** by means of at least one electrical supply cord **111**, preferably routed through feed-through aperture **121** within one of the two end caps **107**, as shown. Preferably, electrical supply cord **111** is electrically coupled to both linear light module **106** and at least one electrical power source (for example, the onboard electrical system of vehicle **101**). Preferably, electrical supply cord **111** comprises at least one electrical conductor (when a grounded vehicle chassis is utilized to complete the circuit), more outer sheath. Upon reading the teachings of this specification, those of ordinary skill in the art will now understand that, under appropriate circumstances, considering such issues as intended use, etc., other electrical supply arrangements, such as the inclusion of ground wires, onboard battery power supplies, onboard switching devices, control circuiting for focusing/positioning servos, etc., may suffice. Preferably, electrical supply cord **111** comprises an annular sealing grommet **120** structured and arranged form a substantially fluid-resistant seal between electrical supply cord **111** and feed-through aperture **121**. Preferably, annular sealing grommet **120** is disposed about electrical supply cord **111** and may be preferably molded integrally with the

outer sheath, as shown. Annular sealing grommet **120** preferably comprises a generally resilient material capable of forming a compression seal with feed-through aperture **121**. Upon reading the teachings of this specification, those of ordinary skill in the art will now understand that, under appropriate circumstances, considering such issues as intended use, cost, etc., other sealing arrangements, such as utilizing detachable connectors, waterproof sealants, etc., may suffice.

FIG. **9** shows a front exploded view of light bar assembly **102**. FIG. **10** shows a rear exploded view of light bar assembly **102** according to the preferred embodiment of FIG. **1**. Both FIG. **9** and FIG. **10** show preferred external and internal components of light bar assembly **102** including central housing section **105**, end caps **107**, mounting assembly **108**, front protective cover **114**, side gaskets **113**, front peripheral gasket **172**, threaded fasteners **109**, and threaded end lock **124**, as shown.

Central housing section **105** is preferably constructed from a rigid material having good thermal conduction characteristics, preferably comprising a heat-transfer coefficient in the range of between about 75 and $235 \text{ W m}^{-1} \text{ K}^{-1} \text{ W/m K}$. In addition, the preferred material of central housing section **105** must be capable of sustaining a continuous operational temperature of at least 85 degrees Centigrade without degradation. Preferred materials include metallic compositions, most preferably an extrusion-formed aluminum alloy. Upon reading the teachings of this specification, those of ordinary skill in the art will now understand that, under appropriate circumstances, considering such issues as intended use, material cost, etc., other arrangements, such as the use of composite structures, engineered plastics, alternate metals, etc., may suffice.

The preferred cross-sectional profile of central housing section **105** comprises a continuous internal hollow cavity **136** structured and arranged to house and securely position linear light module **106**. A preferred sectional profile of central housing section **105** is illustrated in FIG. **25**.

End caps **107** are preferably constructed from a substantially rigid material, preferably a solid metal, most preferably die-cast aluminum. Each end cap **107** comprises an internal channel **127** adapted to receive and retain an end portion front protective cover **114** and projecting alignment tabs **138** to assist in properly aligning end caps **107** with its respective side gasket **113** and open-end portion **112** of central housing section **105**. In addition, each end cap **107** preferably comprises an arrangement of apertures to accommodate the passage of threaded fasteners **109** to central housing section **105**, threaded end locks **124** to elongated support bar **126**, and, if applicable, electrical supply cord **111** to linear light module **106**.

Mounting assembly **108** preferably includes elongated support bar **126**, two or more attachment legs **110**, and threaded fasteners **148**. Elongated support bar **126** preferably comprises a longitudinal axis **128** and length **D** substantially matching length **C** of outer housing assembly **103**, as shown. Elongated support bar **126** preferably comprises a substantially uniform circular section, preferably comprising an outer diameter of about $\frac{3}{4}$ inch. Preferably, elongated support bar **126** is engaged within central housing section **105** by placement within a hollow cylindrical bar-receiving channel **130**. Bar-receiving channel **130** preferably extends through the full longitudinal length of central housing section **105**, as shown, thus allowing substantially the entire bar length **D** of elongated support bar **126** to be received therein. When engaged within bar-receiving channel **130**, elongated support bar **126** functions to continuously support light bar

assembly **102** along substantially the full length **C** of outer housing assembly **103**. Preferably, elongated support bar **126** is retained within bar-receiving channel **130** by the end caps **107** mounted to each end of central housing section **105**, as shown. A continuous slot opening **135**, preferably oriented toward the bottom portion of central housing section **105**, extends along preferably the full length of bar-receiving channel **130** to allow for continuous access to elongated support bar **126** during engagement. This preferred physical feature allows attachment legs **110** to be moved to various positions along light bar assembly **102**, even after attachment legs **110** are coupled to elongated support bar **126**, as described below.

Preferably, threaded fasteners **148** are used to mount attachment legs **110** to both elongated support bar **126** and the underlying vehicle **101**. In a preferred assembly, each threaded fastener **148** is passed through a slotted hole **146** of elongated support bar **126**, passing through continuous slot opening **135** and aperture **150** of attachment leg **110** to engage support structure **119** of the underlying vehicle **101** (see also FIG. **11**). Preferably, a compatible nut **152** is engaged on the portion of threaded fastener **148** extending through support structure **119**. Tensioning of nut **152** against underlying support structure **119** preferably retains attachment leg **110**, and the overall light bar assembly **102**, to the underlying vehicle **101**. In addition, tensioning of nut **152** also enables the engagement of first positional retainer at **132**, as further described in FIG. **11**.

It is important to note that the preferred use of slotted holes **146** within elongated support bar **126** provides to each attachment leg **110** a degree of translational movement along elongated support bar **126** in a preferred orientation generally parallel with longitudinal axis **128** (at least embodying herein wherein such at least one elongated support bar comprises at least one elongated slot structured and arranged to allow translational movement of such at least one threaded tensioner substantially parallel with such at least one longitudinal axis; and at the least embodying herein wherein such at least one attacher comprises at least one axial translator structured and arranged to assist axial translation of such at least one attacher along at least one translational axis oriented substantially parallel to such at least one longitudinal axis of such at least one elongated support bar). The preferred use of multiple slotted holes **146** within the length of elongated support bar **126** provides mounting assembly **108** with a wide range of adjustability. Thus, each attachment leg **110** is preferably coupled to outer housing assembly **103** such that it may slide along the lower portion of outer housing assembly **103** to match the spacing of substantially any mounting hole that may exist or be formed within the underlying vehicle **101**.

Elongated support bar **126** is preferably formed from a substantially rigid material, preferably a metallic material, preferably a metallic material matching the composition of central housing section **105**, most preferably an aluminum alloy. Preferably, the inner diameter of bar-receiving channel **130** is sized to allow substantially free rotation of outer housing assembly **103** about elongated support bar **126**. Thus, the above-described arrangements allow light bar assembly **102** to be pivoted about longitudinal axis **128** to a user-selected orientation most beneficial to the lighting requirements of the underlying vehicle **101**. A selected rotational position of light bar assembly **102** is preferably maintained by engaging either of two retainer assemblies identified herein as first positional retainer **132** and second positional retainer **134**.

Preferably, first positional retainer **132** functions to bias outer surface **140** of elongated support bar **126** toward a position of contact with inner surface **142** of bar-receiving channel **130**. Preferably, both elongated support bar **126** and its outer surface **140** are fixed relative to the underlying vehicle **101** by attachment legs **110**, thus, the frictional interaction between the outer surface **140** of elongated support bar **126** against inner surface **142** maintains light bar assembly **102** in a selected fixed rotational position. The preferred apparatus arrangements of first positional retainer **132** are further described in the sectional view of FIG. **11**.

Second positional retainer **134** is also structured and arranged to assist in retaining light bar assembly **102** in a fixed rotational position relative to elongated support bar **126**. Preferably, second positional retainer **134** comprises a set of threaded end locks **124** preferably adapted to be threadably engaged within a respective end of elongated support bar **126**, after passage through its respective end cap **107**, as shown. In preferred operation, threaded end locks **124** are tightened against a respective end cap **107** to form a frictional hold between the cap and elongated support bar **126**. This preferred arrangement functions to hold elongated support bar **126** in the fixed rotational position relative to the fixed elongated support bar **126**. Preferably, each threaded end lock **124** comprises a threaded coupler, preferably a threaded bolt, most preferably a cap bolt comprising a hex socket, as shown. It is noted that one or both of the above-described retainers may be used independently, or more preferably, in combination. Upon reading the teachings of this specification, those of ordinary skill in the art will now understand that, under appropriate circumstances, considering such issues as intended use, cost, advances in technology, etc., other retaining arrangements, such as remotely controllable motorized pivot mechanisms, fixed (non-adjustable) mountings, pin/socket-based retainers, manual cranks, screws, etc., may suffice.

Linear light module **106** preferably comprises a multipart assembly consisting of a specially constructed composite printed circuit board (CPCB **154**), a plurality of focusing lenses **156**, and a plurality of lens positioners **158** adapted to position the plurality of focusing lenses **156** in an operable position adjacent CPCB **154**, as shown.

The front surface of CPCB **154** preferably comprises a plurality of discrete light sources in the form of LEDs **104**, as shown. Each LEDs **104** preferably comprises an individual emitter package mounted to CPCB **154** using a unique heat-rejecting mounting arrangement, as shown in FIG. **13**. Center-to-center spacing of individual LEDs **104** preferably occurs at 1-inch intervals enabling the development of the preferred modular embodiment lengths. In the preferred embodiment depicted in FIG. **9** and FIG. **10**, CPCB **154** comprises 20 individual LEDs **104**, as shown.

Each LED **104** preferably comprises a low-voltage direct-current (DC) operated emitter. Preferred emitters include the EDISON KLC8 LED, alternately preferably 3-watt LED packages produced under the Luxeon trademark by Philips Lumileds Lighting Company of San Jose, Calif. The outer encapsulating package of LED **104** preferably comprises a clear cover or lens element, which is generally hemispherical in shape and from which light from LED **104** is directed.

CPCB **154** preferably comprises interface circuiting adapted to supply suitable electrical current to each of the plurality of mounted LEDs **104**. The preferred implementation of such interface circuiting is dependent on several design factors including the number of LEDs **104** within linear light module **106**, operational specifications of the selected LED devices, and manufactures recommendations

for the application and use of such LED devices. Thus, engineering and design of preferred embodiments CPCB **154** may include the integration of electronic components/devices to control current and or voltage supplied to the LEDs **104**, as selected and applied by one of ordinary skill in the art.

Another highly preferred aspect of CPCB **154** is the efficient heat dissipation and transfer feature provided by the novel composite structure of CPCB **154**. CPCB **154** preferably comprises a multi-layer assembly designed to control the level of thermal heat generated by LEDs **104** during operation. It is known that excessive heat can reduce both the efficiency and lifespan of an LED. CPCB **154** is preferably designed to maintain LEDs **104** within the component's maximum rated temperature during operation. Thermal control by CPCB **154** is preferably accomplished by shunting thermal energy generated by the LEDs from CPCB **154** to the ambient environment by way of the heat-dissipating fins **116** of outer housing assembly **103**. Further explanation, including a preferred configuration of CPCB **154**, is presented in FIG. **13**.

The plurality of focusing lenses **156** preferably comprise groupings of four individual lens units **160** unified into a unitary lens module **162** by a central supportive frame **164**, as shown (at least embodying herein at least one unifying frame structured and arranged to unify at least four of such at least one focusing lens into a single modular lens element). This preferred arrangement is best illustrated in FIG. **14**. In the preferred embodiment depicted in FIG. **9** and FIG. **10**, 5 unitary lens modules **162** are arranged side-by-side in a generally linear organization, as shown. Preferably, each lens unit **160** of the unitary lens module **162** is designed to focus the light generated by a single PCB-mounted LED **104** into at least one beam pattern. Preferred optical characteristics of lens units **160** are discussed in FIG. **17**.

Lens positioner **158** preferably functions to support unitary lens module **162** in an operable position adjacent to the PCB-mount LEDs **104**. Preferably, each lens positioner **158** comprises four cup-like receivers **166**, each one adapted to receive a lens unit **160** of its respective unitary lens module **162**. In the preferred embodiment depicted in FIG. **9** and FIG. **10**, 5 lens positioners **158** are arranged side-by-side in a generally linear organization, as shown.

Preferably, each unitary lens module **162** is coupled to a single respective lens positioner **158** using a single mechanical fastener **170**, as shown. This preferred modular arrangement allows for the installation, removal, and replacement of individual unitary lens modules **162** within a bank of unitary lens modules **162**. This preferred feature enables development of custom lens combinations, for example, mixed beam patterns comprising combinations of flood beam patterns and spot beam patterns within a single light bar assembly **102**. Preferably, mechanical fasteners **170** further function to couple both unitary lens modules **162** and lens positioners **158** to the underlying CPCB **154**.

Preferably, the transparent front protective cover **114** is sealed to outer housing assembly **103** using front peripheral gasket **172**, as shown. Preferably, front peripheral gasket **172** is preferably engaged between front protective cover **114**, cover receiving slots **174** of central housing section **105**, and end caps **107** (see FIG. **11**). Front peripheral gasket **172** preferably comprises a square sectional profile to increase the sealing area of the gasket. Preferably, both front peripheral gasket **172** and side gaskets **113** function to seal continuous internal hollow cavity **136** from ingress of unwanted environmental infiltrates (fluids, dust, particulate matter, etc.). These preferred arrangements enable outer

housing assembly **103** to achieve an IP67 certification. The aforementioned "IP" number is used in the art to specify the environmental protection of enclosures around electronic equipment. These ratings are determined by specific performance tests. The IP number is composed of two numbers, the first referring to the protection against solid objects and the second against liquids. In general, the higher the number, the better the protection afforded by the enclosure.

It is noted that, due to the substantially complete sealing of light bar assembly **102**, moisture contained in the air trapped within the internal hollow cavity **136** during assembly sometimes formed a thin film on the inner surface of the transparent front protective cover **114**. Applicant determined that a preferred placement of a desiccant within the cavity effectively eliminated this occurrence, even in cold atmospheric temperatures. Preferred desiccant materials include silica gel.

FIG. **11** shows the sectional view **11-11** of FIG. **3** according to the preferred embodiment of FIG. **1**. FIG. **12** shows the sectional view **12-12** of FIG. **3** according to the preferred embodiment of FIG. **1**. In the following discussion, it is helpful to also refer to the sectional view of FIG. **21**. As shown in FIG. **11**, FIG. **12**, and FIG. **21**, linear light module **106** is mounted within continuous internal hollow cavity **136** in direct thermal contact with central housing section **105**. Central housing section **105** preferably comprises a first channel **178** set generally perpendicularly within first internal surface **180**, as shown. A second channel **182**, transverse to and intersecting the first channel **178**, is preferably set within central housing section **105** parallel to first internal surface **180**, as shown. Preferably, first channel **178** and second channel **182** serve to create a T-shaped-cross-section slot **184** extending substantially the full length of central housing section **105**, wherein second channel **182** serves to hold and permit sliding of fastener **186** therein, as shown.

Preferably, fastener **186** comprises nut **188** engaged on attaching screw **190**, as shown. Attaching screw **190** is preferably coupled to linear light module **106** by engagement within aperture **194** of linear light module **106**, as shown. It is preferable for first channel **178** to extend beyond the second channel **182** so as to accommodate a greater range of lengths of attaching screw **190**, which may extend through nut **188**, as shown. Preferably, the first channel **178** is sufficiently deep and wide to accommodate attaching screw **190**. Preferably, second channel **192** is sufficiently wide and tall to accommodate nut **188**.

Preferably, the back face **196** of CPCB **154** is held in direct contact with first internal surface **180** by attaching screw **190** and nut **188**. CPCB **154** preferably comprises an aperture **194** every 2 inches along its length, enabling the use of multiple attaching screws **190** to development continuous and even pressure contact between CPCB **154** and first internal surface **180**. This preferred arrangement enables an efficient transfer of thermal energy between CPCB **154** and central housing section **105** further enhanced by the preferred physical construction of CPCB **154**, as described in FIG. **13**.

FIG. **13** shows an exploded perspective view diagrammatically illustrating preferred heat-dissipating assembly of CPCB **154** according to a preferred embodiment of the present invention. CPCB **154** preferably comprises a three-layer composite assembly, as shown. Preferably, CPCB **154** comprises synthetic printed circuit board (PCB **200**), bonding layer **202**, and thermal transfer plate **204**, as shown. Thermal transfer plate **204** preferably comprises two planar surfaces comprising a heat-absorption surface **205** and a heat-dissipating surface, previously identified as back face

196. Preferably, bonding layer **202** (at least embodying herein at least one positioner structured and arranged to position such at least one circuit board adjacent such at least one thermally-conductive plate) is used to permanently join PCB **200** to surface **205** of thermal transfer plate **204**.

PCB **200** is preferably composed of FR4 glass epoxy supporting copper circuit traces to which the leads of LEDs **104** are electrically coupled. In addition, both PCB **200** and bonding layer **202** comprise a plurality of aperture openings **206**, each one located concurrently with a LED **104**, as shown. Preferably, each aperture opening is of sufficient size to allow LED **104** to pass through PCB **200** and bonding layer **202** to a position of contact with heat absorptive surface **205** of thermal transfer plate **204**, as shown (at least embodying herein wherein such at least one electrically-driven light emitting diode is mounted to such at least one circuit board such that such at least one portion of such at least one electrically-driven light emitting diode passes through such at least one aperture passage to comprise a position of thermal contact with such at least one thermally-conductive plate). Each LED **104** is thermally coupled to thermal heat absorptive surface **205**, preferably using thermally conductive paste **208**, as shown.

Thermal transfer plate **204** is preferably constructed from a material having good thermal conduction characteristics, preferably comprising a heat-transfer coefficient in the range of between about 75 and 235 W m⁻¹ K⁻¹ W/m K. In addition, the preferred material of thermal transfer plate **204** must be capable of sustaining a continuous operational temperature of at least 85 degrees Centigrade without degradation. Preferred materials include metallic compositions, most preferably an aluminum plate. Back face **196** of thermal transfer plate **204** is preferably held in thermal contact with first internal surface **180**, as previously described. Thus, a preferred thermal pathway between each LED **104** and the heat-rejecting/heat-dissipating fins **116** of outer housing assembly **103** is provided (at least embodying herein at least one heat-dissipation assembly structured and arranged to dissipate heat generated by such at least one electrically-driven light emitting diode during production of the light; and at least embodying herein, wherein such at least one electrically-driven light emitting diode comprises at least one position of thermal contact with such at least one heat-absorption surface; and such at least one heat-dissipating surface comprises at least one position of thermal contact with such at least one extruded member). Upon reading the teachings of this specification, those of ordinary skill in the art will now understand that, under appropriate circumstances, considering such issues as cost, advances in technology, etc., other heat-rejection arrangements, such as the use of cooling fans, fluid cooling, bonding the PCB directly to the housing, etc., may suffice.

Referring again to the sectional views of FIG. **11** and FIG. **12**, mounting assembly **108** preferably includes elongated support bar **126**, attachment legs **110**, and threaded fasteners **148**. As noted previously, threaded fastener **148** is passed through slotted hole **146** of elongated support bar **126** to extend outwardly through continuous slot opening **135** and attachment leg **110** to engage support structure **119** of the underlying vehicle **101**, as shown. Preferably, nut **152** is engaged on the distal portion of threaded fastener **148** extending through support structure **119**, as shown. Tensioning of nut **152** against underlying support structure **119** preferably retains attachment leg **110**, and the overall light bar assembly **102**, to the underlying vehicle **101**.

In a preferred assembly, the combination of threaded fastener **148** and nut **152** together function as a tensioner to

15

tension attachment leg 110 to a position of contact with the underside of central housing section 105 and outer surface 140 of elongated support bar 126 to a position of frictional contact with inner surface 142 of the internal bar-receiving channel 130. The above-described structures and arrangements substantially comprise first positional retainer 132 (at least embodying herein at least one threaded tensioner structured and arranged to tension such at least one attacher to at least one position of contact with such at least one linear housing and such at least one outer surface of such at least one elongated support bar to the at least one position of contact with such at least one inner surface of such at least one internal bar-receiving channel).

Each attachment leg 110 preferably comprises surface-conforming structures 210 to provide a means for generally conforming the attachment legs 110 to the underlying geometric profile of support structure 119. The geometric profile may be curved, as in the depicted cylindrical mounting bar, or may be generally planar. The principal preferred conformation of attachment leg 110 is designed to engage a curved surface, as shown. If attachment leg 110 is to be mounted to a planar (or other geometric profile) an accessory insert 212 comprising the appropriate interfacing shape is placed between attachment legs 110 and support structure 119, as illustrated in FIG. 22.

FIG. 14 shows a perspective view of unitary lens module 162 of linear light module 106. FIG. 15 shows a front view of unitary lens module 162 of FIG. 14. FIG. 16 shows a sectional view through the section 16-16 of FIG. 15. Unitary lens module 162 preferably comprises groupings of four individual lens units 160 unified into a unitary lens module 162 by central supportive frame 164, as shown (at least embodying herein at least one unifying frame structured and arranged to unify at least four of such at least one focusing lens into a single modular lens element). In the preferred embodiment depicted in FIG. 9 and FIG. 10, 5 unitary lens modules 162 are arranged side-by-side in a generally linear organization, as shown. Preferably, each lens unit 160 of the unitary lens module 162 is designed to receive the light rays generated by LED 104 and, through a combination of refraction and total internal reflection, focus the light rays into a projected beam pattern. Preferred optical characteristics of lens units 160 are discussed in FIG. 17.

FIG. 17 shows a schematic sectional diagram through a single focusing lens of the modular lens element of FIG. 14.

Referring now to FIG. 17, lens unit 160 preferably comprises two optical parts; a refractive member 216 located symmetrically around optical axis 218, and a total internal reflection (TIR) surface 220 located symmetrically around refractive member 216. Both refractive member 216 and TIR surface 220 are integrated within a rotationally symmetrical, solid transparent body 219, as shown. Preferably, lens unit 160 comprises an input end 222 adapted to receive light generated by LED 104 and an output end 224 from which a generally collimated beam pattern 230 is projected. TIR surface 220 generally approximates a frustoconical section, as shown. The preferred shape of the TIR surface 220 is chosen such that light originating from the LED 104 is emitted by the optical system in a direction substantially parallel to the optical axis 218. The outer TIR surface 220 may preferably comprise a true linear conic section, a spherical section, a hyperbolic curve, or most preferably, an ellipsoidal section.

In the depicted preferred embodiment of lens unit 160, refractive member 216 and TIR surface 220 comprise a substantially concomitant focal point 226, as shown. Focal point 226 is preferably located on optical axis 218 within an

16

internal recess 228 of input end 222, as shown. Internal recess 228 is structured and arranged to enable the output of LED 104 to be located at focal point 226, as shown. TIR surface 220 is configured generally in accordance with the well-known principals of TIR optics. Total internal reflection (TIR) occurs when a light ray traveling in a transparent material encounters an interface with another transparent, but less optically dense material. Lens unit 160 is preferably fabricated from a clear material such as glass or more preferably an optically-clear plastic.

FIG. 17 also diagrammatically shows, by means of arrows, the preferred optical path of the light generated by LED 104. The light is preferably focused by lens unit 160 into the substantially parallel beam pattern 230, either by refraction at the central refractive member 216 or by reflection at TIR surface 220. TIR surface 220 is preferably oriented such that light originating from LED 104 and impinging on TIR surface 220 forms a parallel light beam extending substantially parallel to optical axis 218 (by reflection). The remaining light originating from LED 104 is collimated by the central refractive member 216 (by refraction). Thus, a significant and useful portion of the light originating from LED 104 is redirected entirely within lens unit 160. This avoids the need for additional external reflectors, for example, the application of a reflective coating to the surfaces of lens positioner 158.

Upon reading the teachings of this specification, those of ordinary skill in the art will now understand that, under appropriate circumstances, considering such issues as intended use, etc., other lens designs and focusing arrangements, such as lenses producing flood patterns, lenses producing spot patterns, lenses using Fresnel features, lenses omitting the refractive element, etc., may suffice.

FIG. 18 shows a perspective view of lens positioner 158 structured and arranged to position unitary lens module 162 of FIG. 18 in an operable position over LEDs 104. FIG. 19 shows a front view of a preferred modular grouping of lens positioners 158 and unitary lens module 162 according to the preferred embodiment of FIG. 1. FIG. 20 shows a perspective view of an end lens positioner 158.

Preferably, each receiver 166 of lens positioners 158 preferably comprises a generally frustoconical inner profile substantially matching the outer profile of TIR surface 220. Aperture 168 of receiver 166 (see FIG. 19) allows LED 104 to pass through receiver 166 to internal recess 228 of lens unit 160.

FIG. 21 shows a sectional view, through a transverse section extending through the extruded central housing section 105 of light bar assembly 102, according to the preferred embodiment of FIG. 1. Visible in FIG. 21 is heat-dissipating fins 116, bar-receiving channel 130, continuous slot opening 135, continuous internal hollow cavity 136, inner surface 142, cover receiving slot 174, first channel 178, first internal surface 180, second channel 182, and T-shaped-cross-section slot 184.

FIG. 22 shows a sectional view, through a transverse section extending through light bar assembly 102 showing a preferred mounting to a substantially flat support structure 119 of the underlying vehicle 101, according to the preferred embodiment of FIG. 1. The principal preferred conformation of attachment leg 110 is designed to engage a curved surface, as shown in FIG. 11 and FIG. 12. If attachment leg 110 is to be mounted to a planar (or other geometric profile) an accessory insert 212 comprising the appropriate interfacing shape is placed between attachment legs 110 and support structure 119, as shown. Accessory insert 212 preferably

comprises a substantially resilient material, preferably rubber, alternately preferably a synthetic rubber such as neoprene.

FIG. 23A shows a sectional view through a transverse section extending through an alternate light bar assembly 250 of auxiliary lighting system 100 showing a preferred beam-pattern adjuster 252 according to an alternate embodiment of the present invention. Alternate light bar assembly 250 preferably comprises beam-pattern adjuster 252 whereby a user may selectively adjust the emitted beam pattern from linear light module 256 between at least one flood pattern A and least one focused (spot) beam pattern B, as illustrated in FIG. 23B. Preferably, the beam pattern produced by the unit is selectable by adjusting the distance of the unitary lens modules 162 relative to the LEDs 104. More specifically, beam-pattern adjuster 252 preferably modulates the position of each LED 104 relative to the focal point 226 of its associated lens unit 160.

Preferably, beam-pattern adjuster 252 comprises a linear back plate 254, as shown, to which lens positioners 158 and unitary lens module 162 are mounted, as shown. Preferably, back plate 254 is movably mounted within continuous internal hollow cavity 136 and is separate from thermal transfer plate 204, as shown. One or more positional adjusters 256 are coupled to back plate 254 and extend to a position of user access, as shown. Preferably, user manipulation of positional adjuster 256 results in forward or backward translational movement of back plate 254, lens positioners 158, and unitary lens module 162 relative to LEDs 104. Applicant has determined that, using the depicted arrangement, movement of about 1 and 1/2 mm is sufficient to change the beam pattern between flood beam pattern A and spot beam pattern B. Upon reading the teachings of this specification, those of ordinary skill in the art will now understand that, under appropriate circumstances, considering such issues as intended use, cost, component selection, etc., other arrangements, such as utilizing motorized adjusters, independently adjusting several but not all lenses, etc., may suffice.

Although applicant has described applicant's preferred embodiments of this invention, it will be understood that the broadest scope of this invention includes modifications such as diverse shapes, sizes, and materials. Such scope is limited only by the below claims as read in connection with the above specification. Further, many other advantages of applicant's invention will be apparent to those skilled in the art from the above descriptions and the below claims.

What is claimed is:

1. A lighting system comprising:

- a) at least one linear light module structured and arranged to produce light;
- b) at least one linear housing, comprising at least one housing length, structured and arranged to house said at least one linear light module;
- c) at least one mounting assembly structured and arranged to assist mounting of said at least one linear housing to at least one mountable surface;
- d) wherein said at least one mounting assembly comprises
 - i) at least one elongated support bar structured and arranged to support said at least one linear housing substantially continuously along said at least one housing length, ii) wherein said at least one elongated support bar comprises at least one longitudinal axis and at least one bar length,
 - iii) moveably coupled with said at least one elongated support bar, at least one attacher structured and

arranged to assist fixed attachment of said at least one elongated support bar to the at least one mountable surface,

- iv) wherein said at least one attacher comprises at least one axial translator structured and arranged to assist axial translation of said at least one attacher along at least one translational axis oriented substantially parallel to said at least one longitudinal axis of said at least one elongated support bar;
 - e) wherein said at least one linear housing comprises at least one internal bar-receiving channel structured and arranged to receive therein substantially an entire such bar length of said at least one elongated support bar; and
 - f) wherein said at least one linear housing is structured and arranged to be rotatable about said at least one longitudinal axis when engaged within said at least one internal bar-receiving channel.
2. The lighting system according to claim 1 wherein said at least one linear housing comprises:
- a) at least one extruded member having open ends and at least one internal hollow cavity structured and arranged to house said at least one linear light module;
 - b) at least one end cap structured and arranged to cap said open ends;
 - c) at least one front protective cover structured and arranged to protectively cover at least one front portion of said at least one internal hollow cavity;
 - d) wherein said at least one front protective cover comprises at least one substantially transparent composition structured and arranged transparently pass the light produced by said at least one linear light module therethrough.
3. The lighting system according to claim 1 further comprising at least one environmental infiltrate blocker structured and arranged to block the passage of environmental infiltrates into said at least one internal hollow cavity through mated engagements of said at least one extruded member.
4. The lighting system according to claim 2 further comprising:
- a) situate between each said at least one end cap and each said at least one open end, at least one end seal structured and arranged to seal said at least one end cap to a respective said at least one open end; and
 - b) situate between said at least one front protective cover, said at least one end cap, and said at least one extruded member, at least one front seal structured and arranged to seal said at least one front protective cover to said at least one end cap and said at least one extruded member;
 - c) wherein said at least one end seal and said at least one front seal assist in blocking the intrusion of environmental infiltrates to within said at least one internal hollow cavity.
5. The lighting system according to claim 4 wherein said at least one linear light module comprises:
- a) at least one electrically-driven light emitting diode structured and arranged to generate light;
 - b) at least one focusing lens structured and arranged to focus the generated light into at least one beam pattern; and
 - c) at least one lens positioner structured and arranged to position said at least one focusing lens relative to said at least one light source;
 - d) wherein said at least one focusing lens produces such at least one beam pattern by total internal reflection.

6. The lighting system according to claim 5 wherein said at least one focusing lens produces such at least one beam pattern by total internal reflection and refraction.

7. The lighting system according to claim 5 further comprising at least one unifying frame structured and arranged to unify at least four of said at least one focusing lens into a single modular lens element.

8. The lighting system according to claim 5 wherein said at least one linear light module further comprises:

- a) at least one heat-dissipation assembly structured and arranged to dissipate heat generated by said at least one electrically-driven light emitting diode during production of the light;
- b) wherein said at least one heat-dissipation assembly comprises
 - i) at least one circuit board structured and arranged to provide circuit-board support of said at least one electrically-driven light emitting diode,
 - ii) at least one thermally-conductive plate structured and arranged to absorb and dissipate the heat, and
 - iii) at least one positioner structured and arranged to position said at least one circuit board adjacent said at least one thermally-conductive plate;
- c) wherein said at least one circuit board comprises at least one aperture structured and arranged to pass at least one portion of said at least one electrically driven light emitting diode therethrough;
- d) wherein said at least one electrically-driven light emitting diode is mounted to said at least one circuit board such that such at least one portion of said at least one electrically-driven light emitting diode passes through said at least one aperture passage to comprise a position of thermal contact with said at least one thermally-conductive plate.

9. The lighting system according to claim 8 wherein:

- a) said at least one thermally-conductive plate comprises at least one heat-absorption surface and at least one heat-dissipating surface;
- b) said at least one electrically-driven light emitting diode comprises at least one position of thermal contact with said at least one heat-absorption surface; and
- c) said at least one heat-dissipating surface comprises at least one position of thermal contact with said at least one extruded member;
- d) whereby the heat generated by said at least one electrically-driven light emitting diode during production of the light is dissipated by a transfer of heat energy to said at least one extruded member.

10. The lighting system according to claim 9 wherein said at least one extruded member comprises:

- a) at least one external heat-rejection region structured and arranged to assist rejection of the heat from said at least one extruded member to a surrounding environment;
- b) wherein said at least one external heat-rejection region comprises a plurality of fins structured and arranged to provide increased surface area in thermal communication with the surrounding environment.

11. The lighting system according to claim 5 wherein said at least one mounting assembly further comprises:

- a) at least one first positional retainer structured and arranged to positionally retain said at least one linear housing in at least one fixed rotational position relative to said at least one elongated support bar;
- b) wherein said at least one first positional retainer comprises at least one adjustable biaser structured and arranged to adjust ably bias at least one outer surface of

said at least one elongated support bar toward at least one position of contact with at least one inner surface of said at least one internal bar receiving channel;

- c) wherein said at least one first positional retainer assists in maintaining such at least one fixed rotational position substantially by at least one frictional interaction between such at least one outer surface of said at least one elongated support bar and such at least one inner surface of said at least one internal bar-receiving channel.

12. The lighting system according to claim 11 wherein said at least one adjustable biaser comprises:

- a) at least one threaded tensioner structured and arranged to tension said at least one attacher to at least one position of contact with said at least one linear housing and such at least one outer surface of said at least one elongated support bar to the at least one position of contact with such at least one inner surface of said at least one internal bar receiving channel;
- b) wherein said at least one elongated support bar comprises at least one elongated slot structured and arranged to allow translational movement of said at least one threaded tensioner substantially parallel with said at least one longitudinal axis; and
- c) wherein said at least one threaded tensioner is structured and arranged to pass through said at least one elongated slot during such coupling of said at least one attacher with said at least one elongated support bar.

13. The lighting system according to claim 12 wherein said at least one mounting assembly further comprises:

- a) at least one second positional retainer structured and arranged to retain said at least one linear housing in at least one fixed rotational position relative to said at least one elongated support bar;
- b) wherein said at least one second positional retainer comprises at least one threaded end lock structured and arranged to positionally lock said at least one end cap in at least one fixed rotational position relative to said at least one elongated support bar.

14. The lighting system according to claim 13 wherein said at least one end lock comprises at least one threaded coupler structured and arranged to frictionally couple said at least one end cap to said at least one elongated support bar.

15. The lighting system according to claim 14 further comprising at least one conformer structured and arranged to conform said at least one attacher to at least one geometric profile of the at least one mountable surface.

16. The lighting system according to claim 15 wherein said at least one conformer is structured and arranged to be attachable to at least one generally radiused profile of the at least one mountable surface.

17. The lighting system according to claim 15 wherein said at least one conformer is structured and arranged to be attachable to a generally planar of the at least one mountable surface.

18. The lighting system according to claim 15 wherein said at least one conformer comprises at least one dampener structured and arranged to dampen transmission of mechanical forces through said at least one attacher.

19. The lighting system according to claim 15 wherein each said at least one attacher is independently adjustable along the at least one longitudinal axis of said at least one elongated support bar.

20. A lighting system comprising:

- a) at least one linear light module configured to produce light;

21

- b) at least one linear housing, comprising at least one housing length and configured to house the at least one linear light module, wherein the at least one linear housing comprises an elongated body portion formed to include at least one elongated channel; 5
- c) at least one end cap coupled to the elongated body portion of the at least one linear housing;
- d) at least one mounting assembly configured to permit mounting of the at least one linear housing to at least one mountable surface, wherein the at least one mounting assembly includes a support bar positioned to contact an inner surface of the channel, an attachment member positioned to contact an outer surface of the channel, and a fastener coupled between the support bar and the attachment member, the attachment member and fastener configured to be movable along at least a portion of the length of the elongated body portion of the at least one linear housing, the fastener configured to provide a release position to allow movement of the attachment member relative to the at least one linear housing and a secure position fixing a location of the attachment member relative to the at least one linear housing, and at least a portion of the attachment member being substantially rotatably fixed relative to the support bar about a longitudinal axis of the support bar when the fastener is in both the release and secure positions. 10 15 20 25

21. The lighting system of claim 20, wherein the at least one mounting assembly includes at least a first attachment member and a second attachment member, the first and second attachment members being independently positionable laterally along the length of the elongated body portion. 30

22. The lighting system of claim 20, wherein the at least one mounting assembly further includes at least one fastener coupled between the support bar and the attachment mem-

22

ber to permit adjustment of the attachment member with respect to the elongated body portion.

23. A lighting system comprising:

a) at least one linear light module configured to produce light;

b) at least one linear housing, comprising at least one housing length and configured to house the at least one linear light module, wherein the at least one linear housing comprises an elongated body portion formed to include at least one elongated channel; 10

c) a first end cap coupled to a first end of the elongated body portion and a second end cap coupled to a second end of the elongated body portion of the at least one linear housing;

d) a lens coupled to the at least one linear housing; and

e) at least one mounting assembly configured to permit mounting of the at least one linear housing to at least one mountable surface, wherein the at least one mounting assembly includes a fastener, a portion of which is positioned within the channel, and an attachment member coupled to the fastener and positioned to contact an outer surface exterior to the channel, the attachment member and fastener configured to be movable laterally along the length of the elongated body portion of the at least one linear housing, the fastener configured to provide a release position to allow movement of the attachment member relative to the at least one linear housing and a secure position fixing a location of the attachment member relative to the at least one linear housing, and at least a portion of the attachment member being substantially rotatably fixed relative to the fastener about an axis extending along the at least one linear housing within the channel when the fastener is in both the release and secure positions. 15 20 25 30

* * * * *