



US00RE46132E

(19) **United States**
(12) **Reissued Patent**
Chen

(10) **Patent Number:** **US RE46,132 E**
(45) **Date of Reissued Patent:** **Aug. 30, 2016**

(54) **ELECTRONIC DEVICE WITH BIAxIAL PIVOTING MECHANISM**

(71) Applicant: **Wistron Corporation**, New Taipei (TW)

(72) Inventor: **Yi-Chuan Chen**, New Taipei (TW)

(73) Assignee: **Wistron Corporation**, New Taipei (TW)

(21) Appl. No.: **14/294,138**

(22) Filed: **Jun. 2, 2014**

Related U.S. Patent Documents

Reissue of:

(64) Patent No.: **8,320,123**
Issued: **Nov. 27, 2012**
Appl. No.: **13/088,430**
Filed: **Apr. 18, 2011**

(30) **Foreign Application Priority Data**

Apr. 20, 2010 (TW) 99207172 U

(51) **Int. Cl.**
G06F 1/16 (2006.01)

(52) **U.S. Cl.**
CPC **G06F 1/1681** (2013.01)

(58) **Field of Classification Search**
CPC G06F 1/1681
USPC 361/679.59, 679.02, 679.26, 679.27,
361/679.55; 312/223.1, 223.2; 248/254,
248/918, 919

See application file for complete search history.

(56) **References Cited**

U.S. PATENT DOCUMENTS

5,901,035	A *	5/1999	Foster et al.	361/679.55
6,097,592	A *	8/2000	Seo et al.	361/679.55
6,154,359	A *	11/2000	Kamikakai et al.	361/679.27
6,473,296	B2 *	10/2002	Amemiya et al.	361/679.27
6,961,240	B2 *	11/2005	Janicek	361/679.46
7,679,905	B2 *	3/2010	Wu et al.	361/679.59
7,821,786	B2 *	10/2010	Hadad et al.	361/679.59
7,855,883	B2 *	12/2010	Tang	361/679.55
7,948,753	B2 *	5/2011	Wang	361/679.59
2010/0118481	A1 *	5/2010	Wang	361/679.27
2011/0164377	A1 *	7/2011	Wang	361/679.55

* cited by examiner

Primary Examiner — Minh T Nguyen

(74) *Attorney, Agent, or Firm* — Winston Hsu; Scott Margo

(57) **ABSTRACT**

An electronic device includes a first housing, a first pivoting mechanism disposed on a side of the first housing, a second housing, a second pivoting mechanism disposed on a side of the second housing, and a bridging component. A first end and a second end of the bridging component are respectively pivoted on the first pivoting mechanism and the second pivoting mechanism. The bridging component includes a first contacting portion for contacting against the side of the first housing when the first pivoting mechanism pivots on the first end so that the first housing rotates around the second housing at a first angle, and a second contacting portion for contacting against the side of the second housing when the second end pivots on the second pivoting mechanism so that the first housing rotates around the second housing at a second angle greater than the first angle.

15 Claims, 9 Drawing Sheets

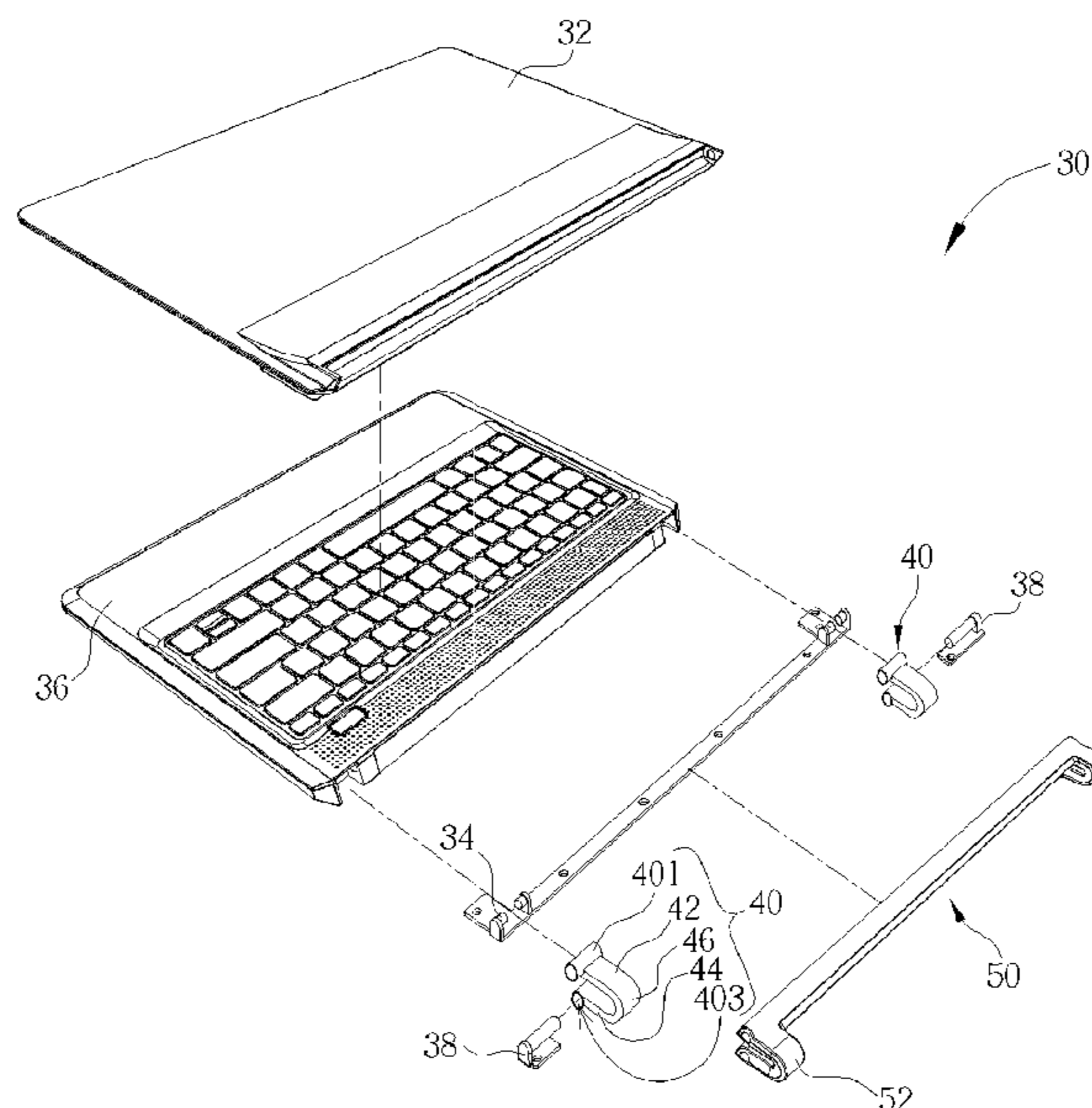

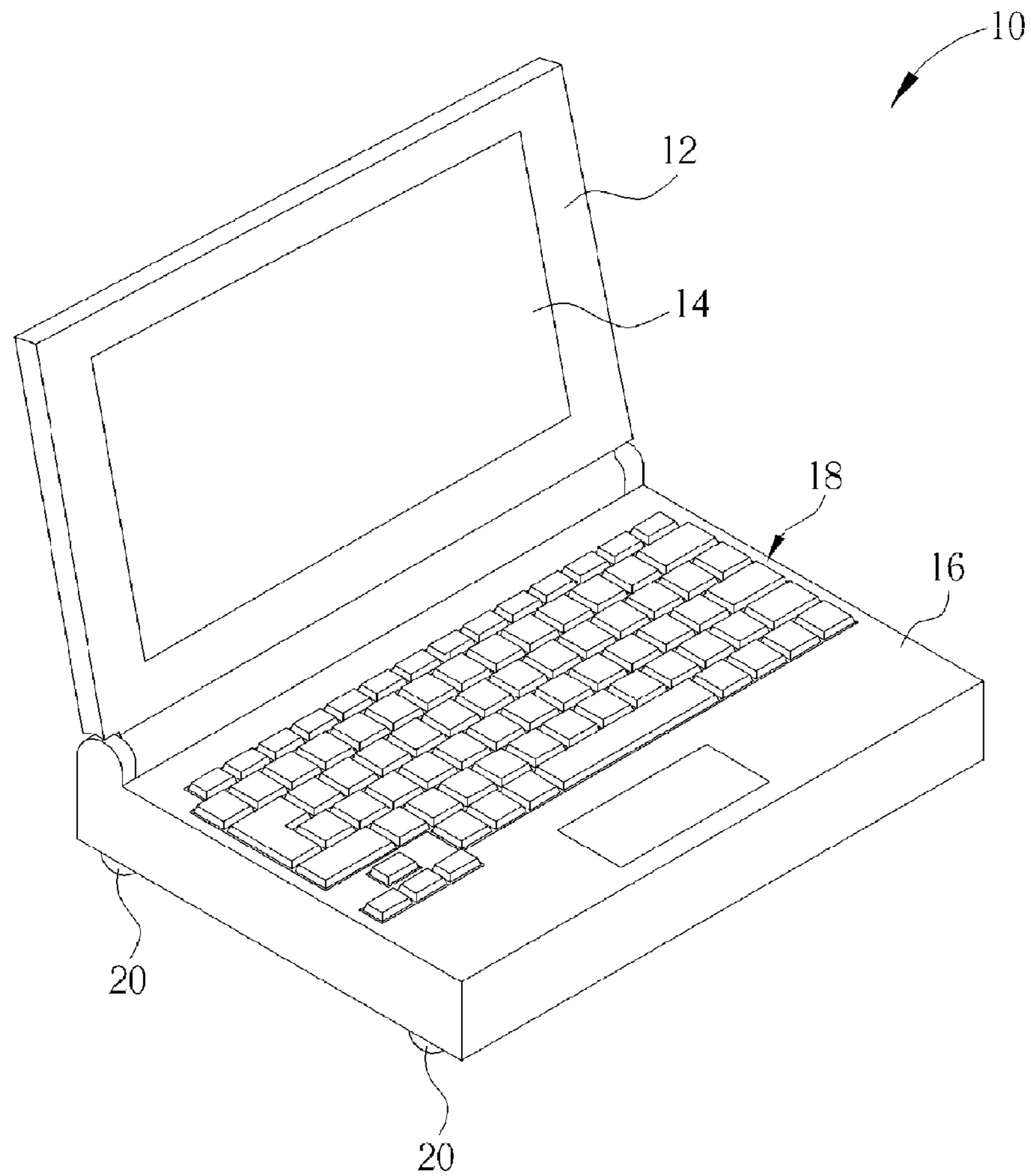

FIG. 1 PRIOR ART

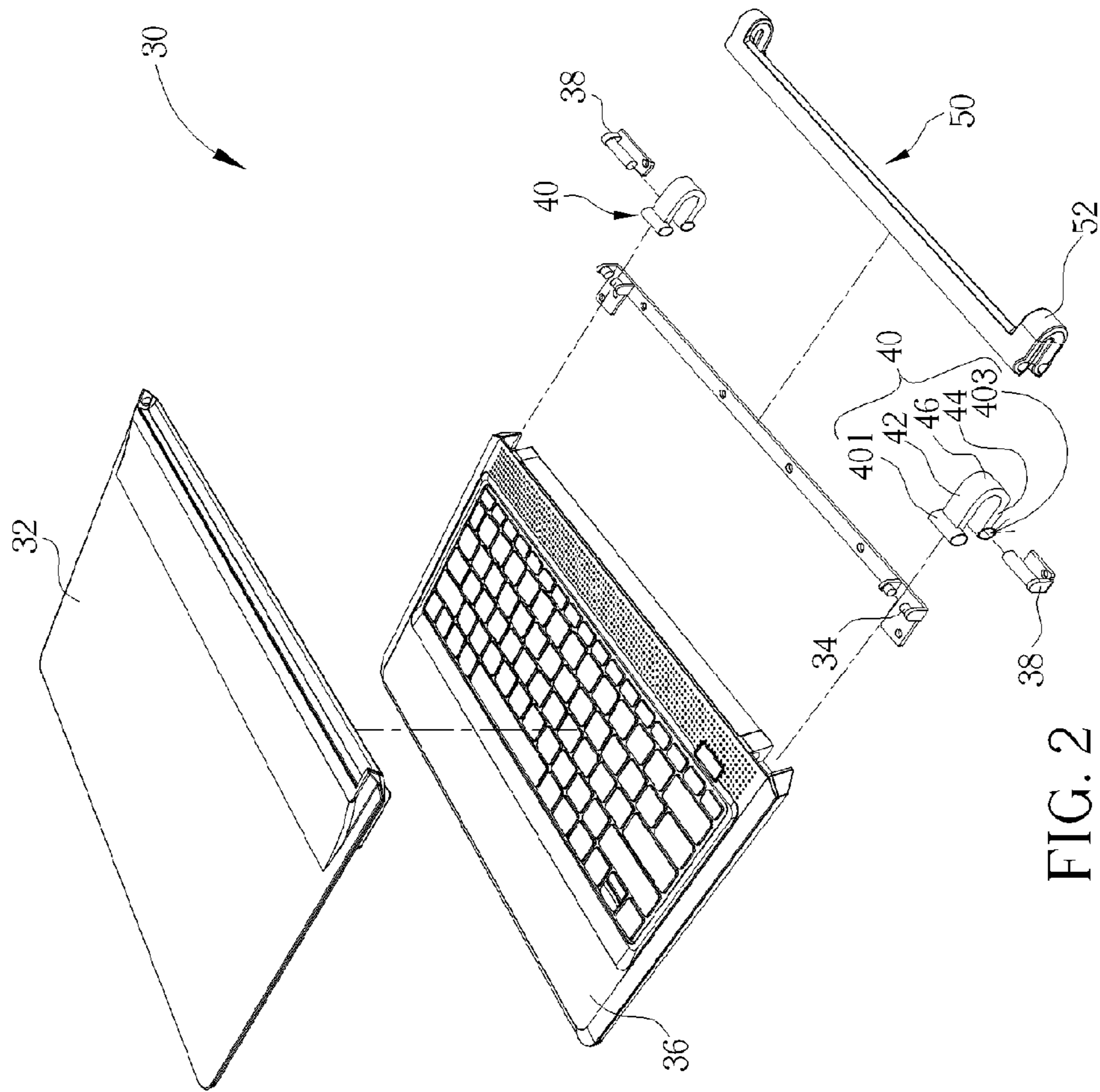

FIG. 2

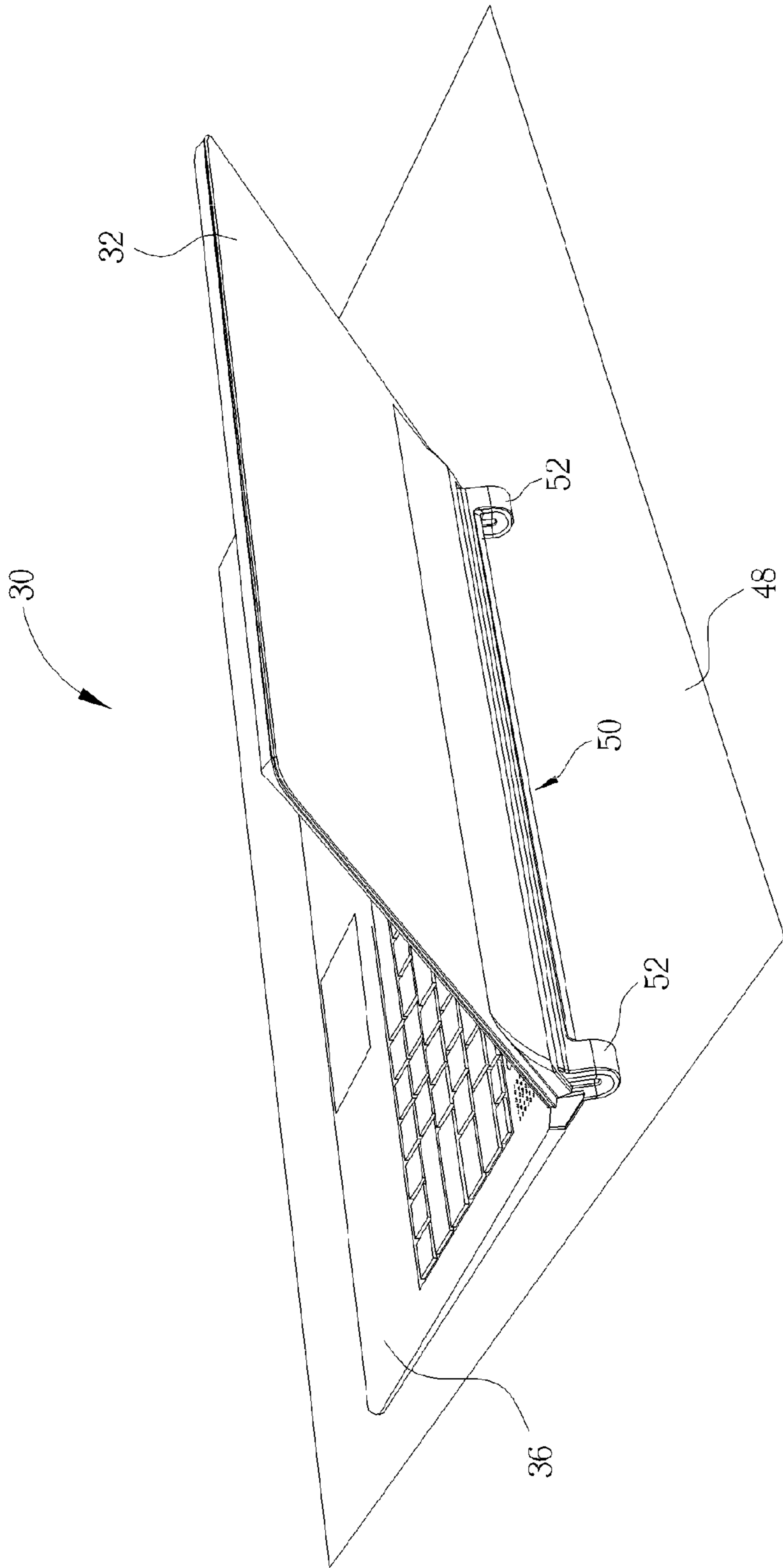

FIG. 3

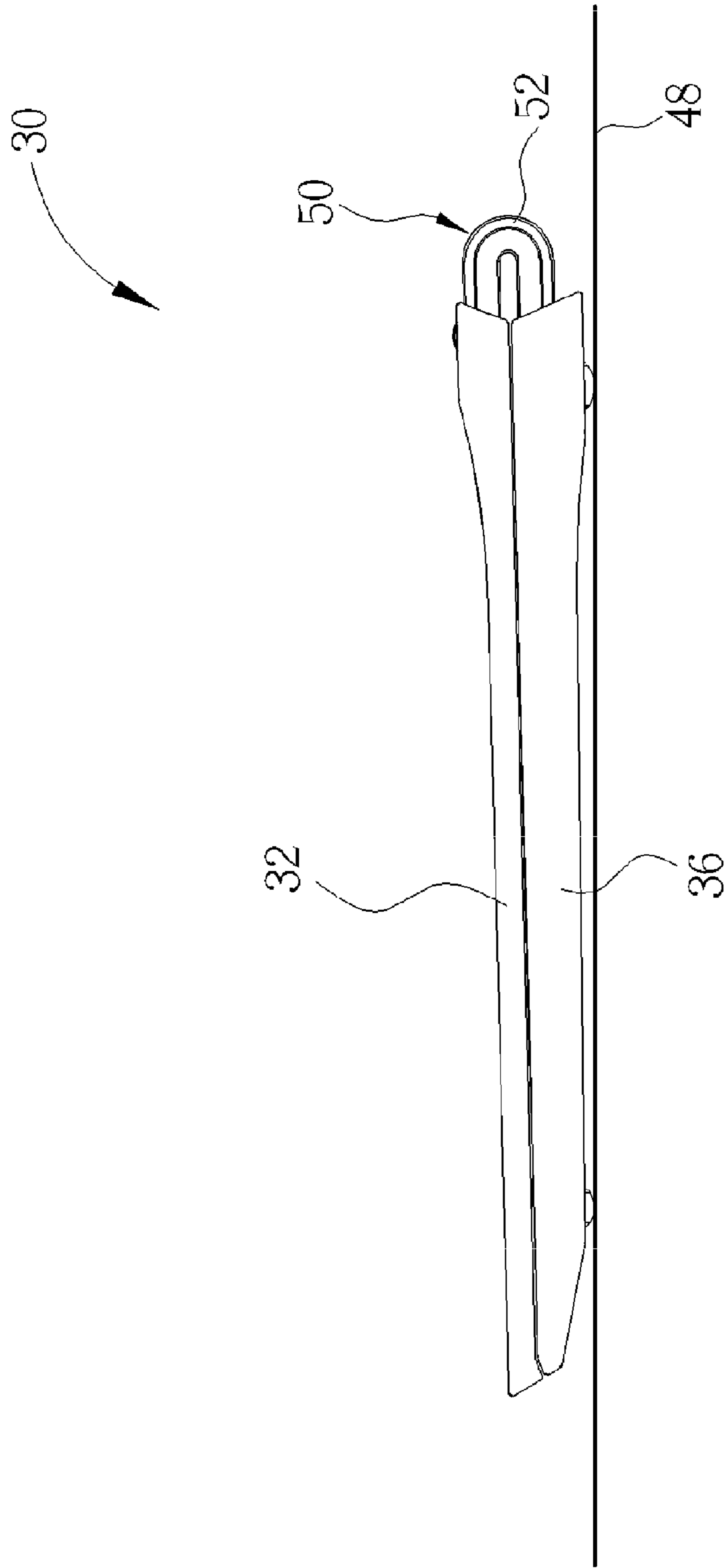

FIG. 4

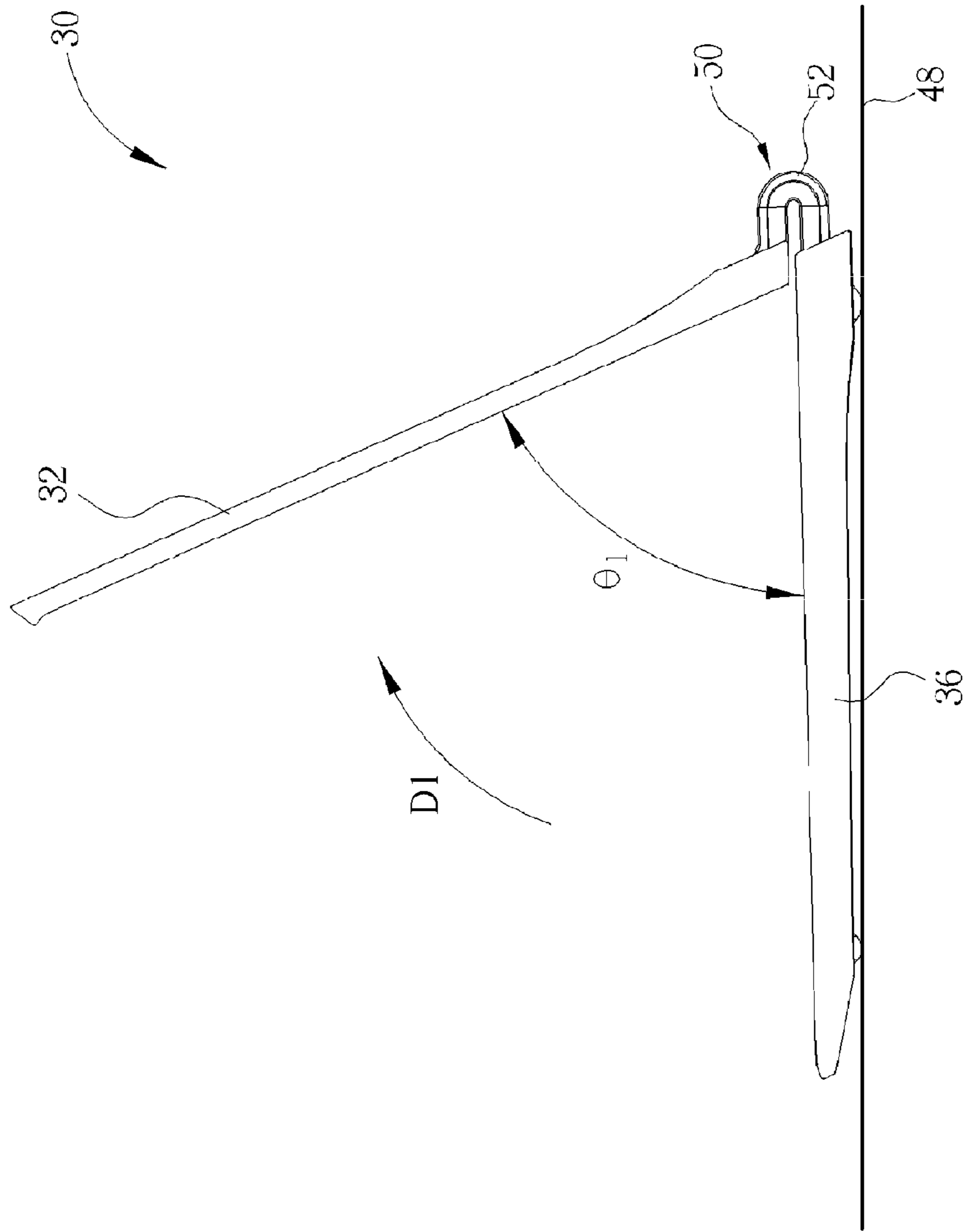

FIG. 5

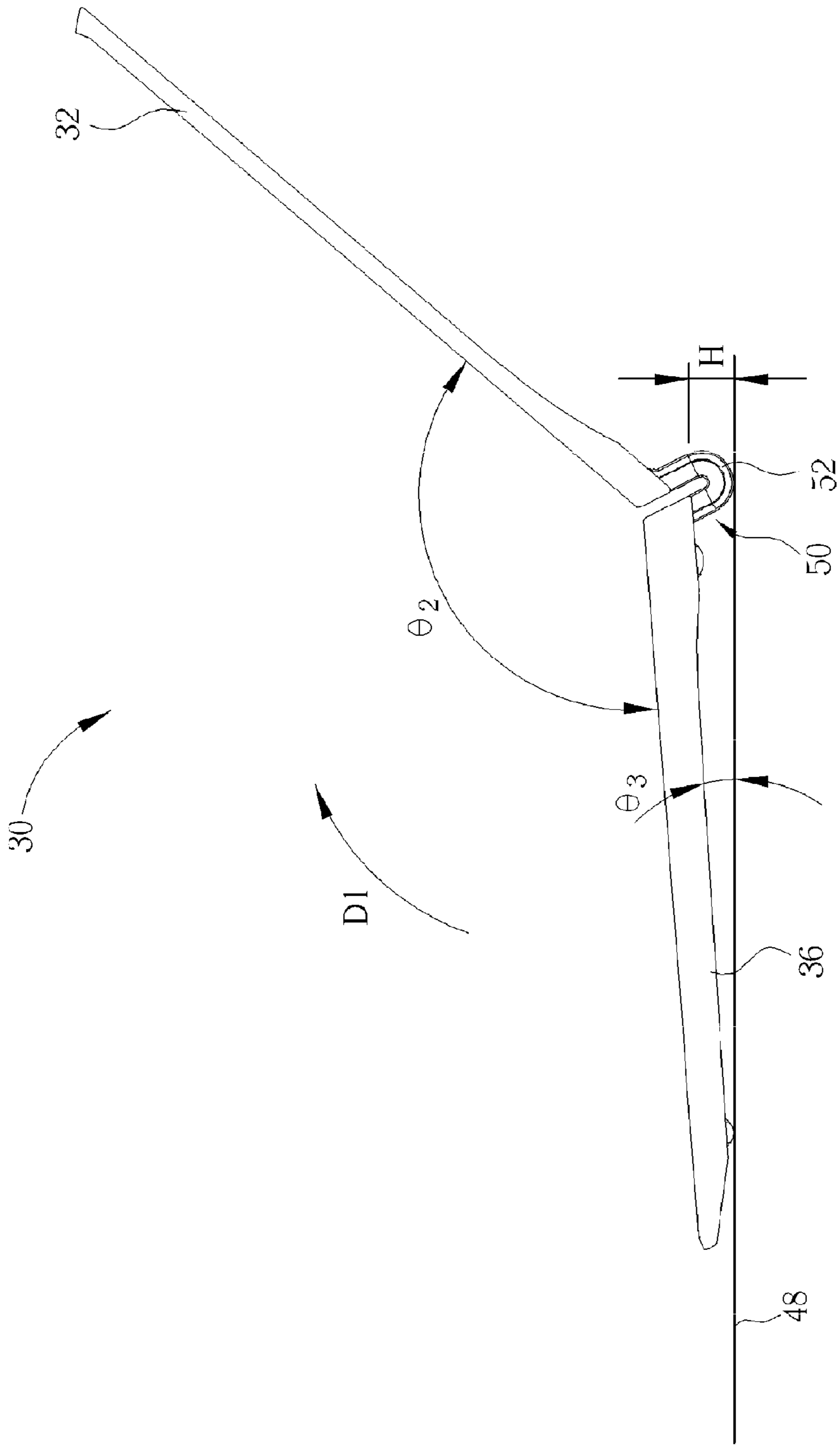

FIG. 6

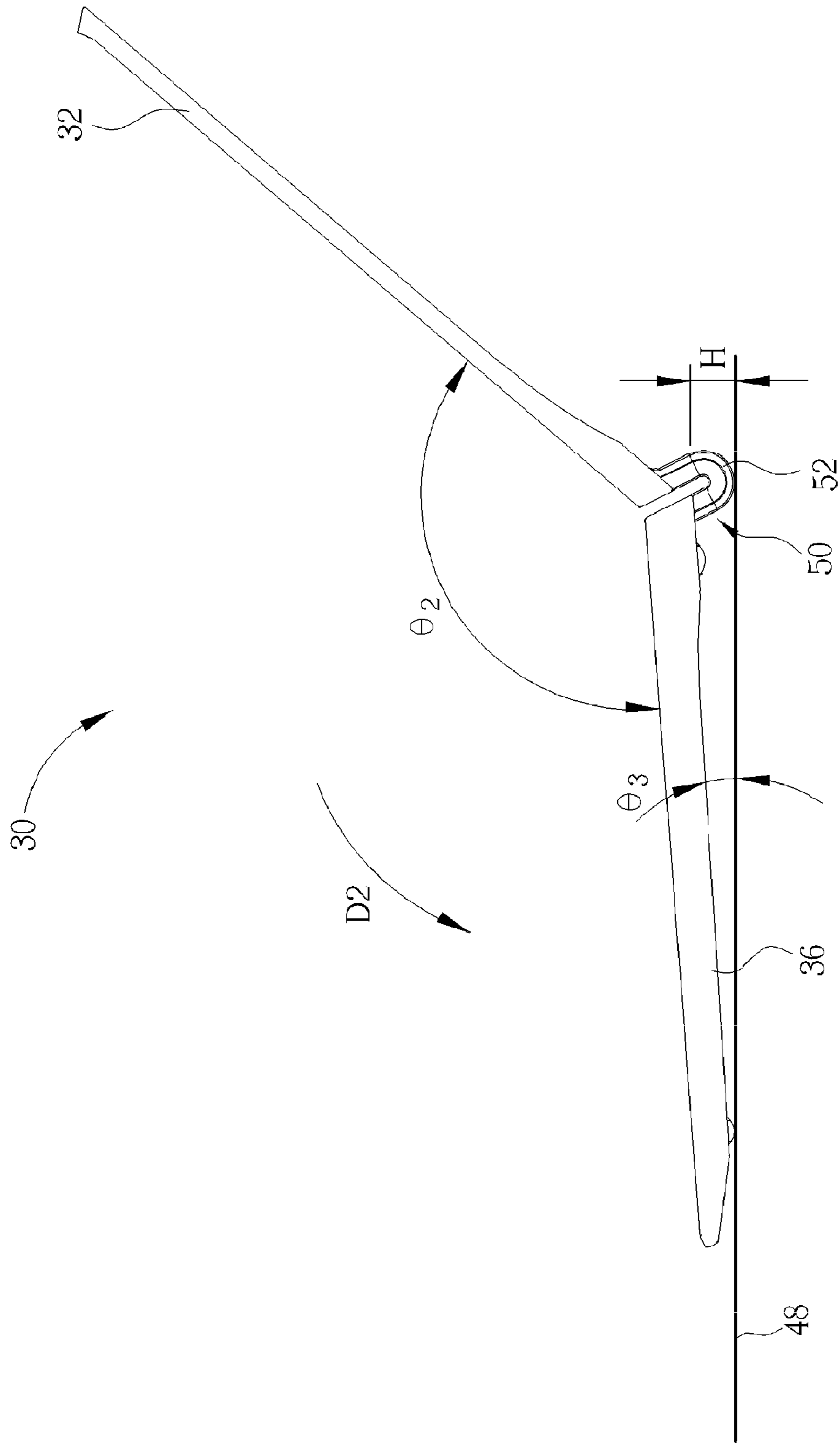

FIG. 7

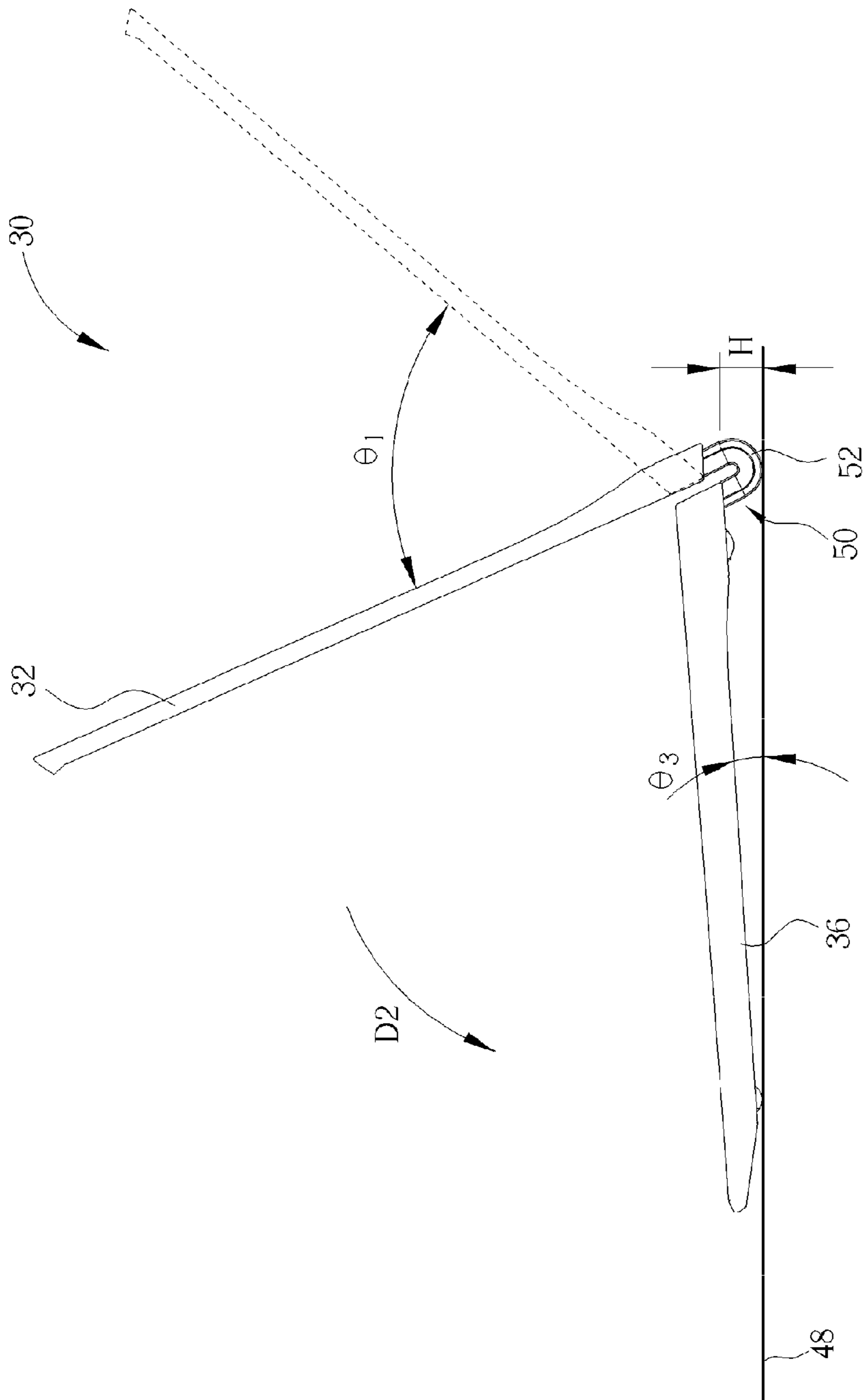

FIG. 8

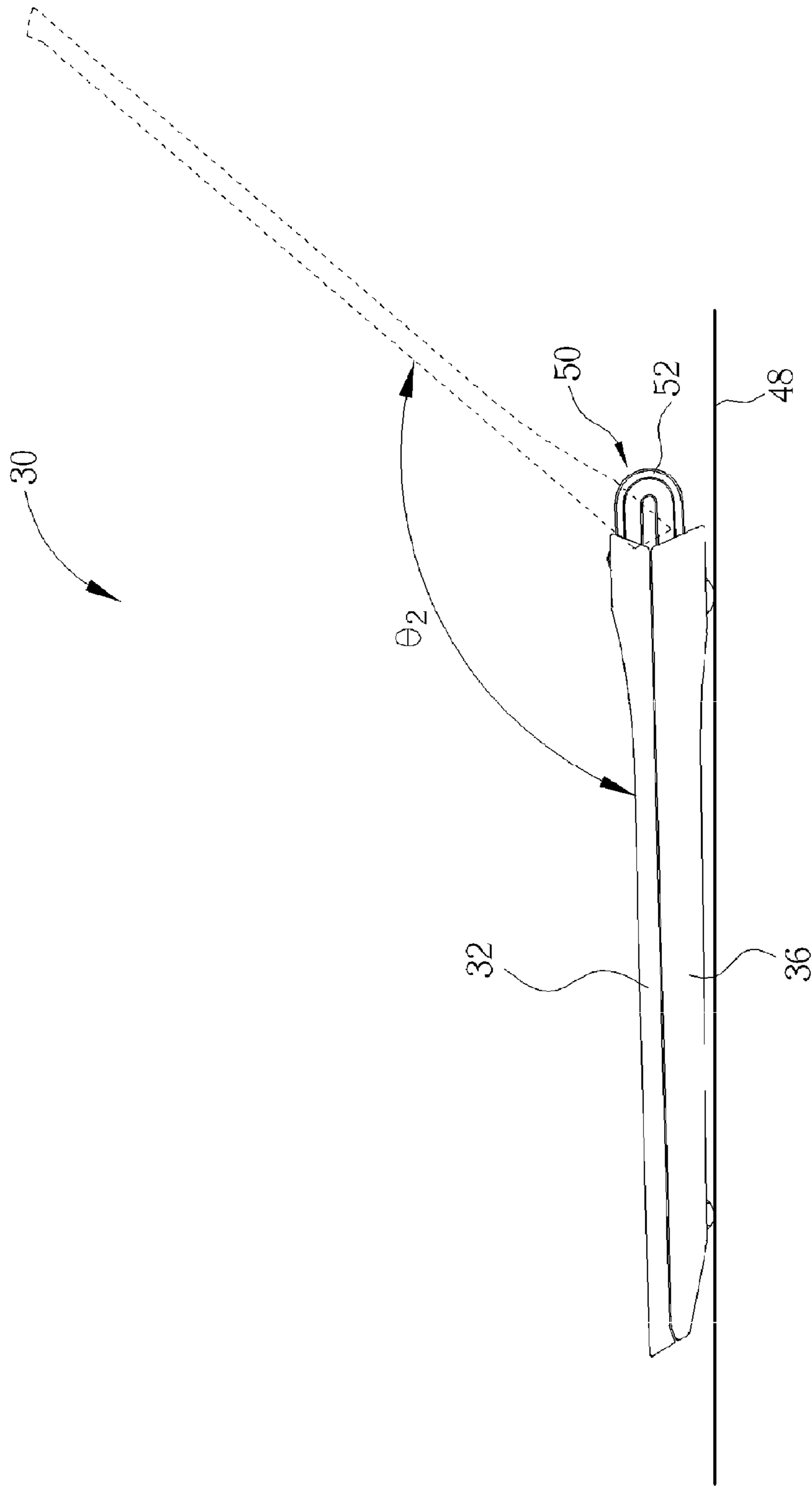

FIG. 9

1

ELECTRONIC DEVICE WITH BIAXIAL PIVOTING MECHANISM

Matter enclosed in heavy brackets [] appears in the original patent but forms no part of this reissue specification; matter printed in italics indicates the additions made by reissue; a claim printed with strikethrough indicates that the claim was canceled, disclaimed, or held invalid by a prior post-patent action or proceeding.

BACKGROUND OF THE INVENTION

1. Field of the Invention

The present invention relates to an electronic device with a biaxial pivoting mechanism, and more particularly, to an electronic device with a biaxial pivoting mechanism for ergonomic design.

2. Description of the Prior Art

Please refer to FIG. 1. FIG. 1 is a diagram of a portable electronic device **10** in the prior art. The portable electronic device **10** includes an upper housing **12** whereon a display **14** is disposed, and a lower housing **16** whereon a keyboard **18** and other electronic components are disposed. Generally, the portable electronic device **10** further includes at least one protrusion **20** disposed on a bottom of the lower housing **16** for preventing abrasion of the bottom of the lower housing **16**. The protrusion **20** of the portable electronic device **10** is small for preferred appearance, so that the lower housing **16** is horizontally placed on the table. Therefore, an inclined angle of the keyboard **18** of the portable electronic device **10** relative to the table does not correspond with a ergonomic design, and results ankylosis of a shoulder, a neck, and a wrist. In addition, a gap between the bottom of the lower housing **16** and the table is small, so that the portable electronic device **19** does not dissipate heat effectively. Thus, design of a portable electronic device having a pivoting mechanism with aesthetic and practicability is an important issue of the electronic industry.

SUMMARY OF THE INVENTION

The present invention provides an electronic device with a biaxial pivoting mechanism for ergonomic design for solving above drawbacks.

According to the claimed invention, an electronic device includes a first housing, a first pivoting mechanism disposed on a side of the first housing, a second housing, a second pivoting mechanism disposed on a side of the second housing, and a bridging component. A first end and a second end of the bridging component are respectively pivoted on the first pivoting mechanism and the second pivoting mechanism. The bridging component includes a first contacting portion for contacting against the side of the first housing when the first pivoting mechanism pivots on the first end so that the first housing rotates around the second housing at a first angle, and a second contacting portion for contacting against the side of the second housing when the second end pivots on the second pivoting mechanism so that the first housing rotates around the second housing at a second angle greater than the first angle.

According to the claimed invention, a torque of the first pivoting mechanism pivoting on the first end is smaller than a torque of the second pivoting mechanism pivoting on the second end.

According to the claimed invention, the bridging component comprises a bending portion connected to the first

2

contacting portion and the second contacting portion and disposed on a supporting surface, and the bending portion rotates around the supporting surface to drive the second end of the bridging component to pivot on the second pivoting mechanism so that a gap is formed between the second housing and the supporting surface when the side of the first housing contacts against the first contacting portion of the bridging component.

According to the claimed invention, a third angle is formed between the second housing and the supporting surface when the side of the second housing contacts against the second contacting portion of the bridging component.

According to the claimed invention, the third angle is substantially less than 5 degrees.

According to the claimed invention, the bridging component is a U-shaped structure.

According to the claimed invention, the first angle is substantially 67.5 degrees.

According to the claimed invention, the second angle is substantially 135 degrees.

According to the claimed invention, a covering component is for covering the bridging component.

According to the claimed invention, a buffer is disposed on an outer side of the covering component for preventing abrasion of the covering component.

These and other objectives of the present invention will no doubt become obvious to those of ordinary skill in the art after reading the following detailed description of the preferred embodiment that is illustrated in the various figures and drawings.

BRIEF DESCRIPTION OF THE DRAWINGS

FIG. 1 is a diagram of a portable electronic device in the prior art.

FIG. 2 is an exploded diagram of an electronic device according to a one of the embodiments of the present invention.

FIG. 3 is an assembly diagram of the electronic device according to one of the embodiments of the present invention.

FIG. 4 is a diagram of the closed electronic device according to one of the embodiments of the present invention.

FIG. 5 is a diagram of the electronic device in an opening process according to one of the embodiments of the present invention.

FIG. 6 is a diagram of the electronic device at a maximal angle according to one of the embodiments of the present invention.

FIG. 7 is a diagram of the electronic device at the maximal angle according to one of the embodiments of the present invention.

FIG. 8 is a diagram of the electronic device in the closing process according to one of the embodiments of the present invention.

FIG. 9 is a diagram of the closed electronic device according to one of the embodiments of the present invention.

DETAILED DESCRIPTION

Please refer to FIG. 2 and FIG. 3. FIG. 2 is an exploded diagram of an electronic device **30** according to an embodiment of the present invention. FIG. 3 is an assembly diagram of the electronic device **30** according to the embodiment of the present invention. The electronic device **30** can be a

portable computer device, such as a notebook computer. The electronic device 30 includes a first housing 32, and a first pivoting mechanism 34 disposed on a side of the first housing 32. The first housing 32 can be an upper housing of the electronic device 30 for containing a liquid crystal display. The electronic device 30 further includes a second housing 36, and a second pivoting mechanism 38 disposed on a side of the second housing 36. The second housing 36 can be a lower housing of the electronic device 30 for containing a keyboard and other electronic components, such as a main board, a hard disk, and so on. The electronic device 30 further includes a bridging component 40. A first end 401 and a second end 402 of the bridging component 40 are respectively pivoted on the first pivoting mechanism 34 and the second pivoting mechanism 38. Therefore, the first housing 32 can pivot on the bridging component 40 via the first pivoting mechanism 34, and the bridging component 40 can pivot on the second housing 36 via the second pivoting mechanism 38, so that the electronic device 30 can be folded by pivoting the first housing 32 on the second housing 36. The electronic device 30 can further include a covering component 50 for covering the bridging component 40, so as to prevent abrasion of the bridging component 40. The electronic device 30 can further include a buffer 52 disposed on an outer side of the covering component 50. When the electronic device 30 is placed on a supporting surface 48, the buffer 52 can prevent abrasion of the covering component 50 due to rubbing with the supporting surface 48.

In addition, the bridging component 40 includes a first contacting portion 42. When the first pivoting mechanism 34 pivots on the first end 401 of the bridging component 40 so as to rotate the first housing 32 around the second housing 36 at a first angle θ_1 , the first contacting portion 42 contacts against the side of the first housing 32, so as to constrain a rotation between the first housing 32 and the bridging component 40. Generally, the first angle θ_1 can be 67.5 degrees. The bridging component 40 further includes a second contacting portion 44. When the second end 403 of the bridging component 40 pivots on the second pivoting mechanism 38 so as to rotate the first housing 32 around the second housing 36 at a second angle θ_2 substantially greater than the first angle θ_1 , the second contacting portion 44 contacts against the side of the second housing 36, so as to constrain a rotation between the bridging component 40 and the second housing 36. Generally, the second angle θ_2 can be 135 degrees. Besides, a torque of the first pivoting mechanism 34 pivoting on the first end 401 is smaller than a torque of the second pivoting mechanism 38 pivoting on the second end 403. That is to say, when the first housing 32 starts to rotate, the bridging component 40 does not rotate around the second housing 36 immediately until the side of the first housing 32 contacts against the first contacting portion 42. When the side of the first housing 32 contacts against the first contacting portion 42, the first pivoting mechanism 34 can not pivot on the first end 401 of the bridging component 40 and the second pivoting mechanism 38 starts to pivot on the second end 403 of the bridging component 40. Values of the first angle θ_1 and the second angle θ_2 are not limited to the above-mentioned embodiment, and it depends on design demand.

Furthermore, the bridging component 40 can further include a bending portion 46 connected to the first contacting portion 42 and the second contacting portion 44 for placing on a supporting surface 48. For example, the bridging component 40 can be a U-shaped structure. When the first housing 32 rotates around the bridging component 40 and the side of the first housing 32 contacts against the first

contacting portion 42 of the bridging component 40, the bending portion 46 can rotate around the supporting surface 48, so as to drive the second end 403 of the bridging component 40 to pivot on the second pivoting mechanism 38, and to form a gap H between the second housing 36 and the supporting surface 48. The gap H varies with the rotation angle of the bending portion 46 relative to the supporting surface 48. For example, there is the maximum gap H when the side of the second housing 36 contacts against the second contacting portion 44. At this time, a third angle θ_3 is formed between the second housing 36 and the supporting surface 48, and the third angle θ_3 can be substantially less than 5 degrees. Values of the third angle θ_3 is not limited to the above-mentioned embodiment, and it depends on design demand.

Please refer to FIG. 2 and FIG. 4 to FIG. 6. FIG. 4 is a diagram of the closed electronic device 30 according to one of the embodiments of the present invention. FIG. 5 is a diagram of the electronic device 30 in an opening process according to one of the embodiment of the present invention. FIG. 6 is a diagram of the electronic device 30 at a maximal opening angle according to one of the embodiments of the present invention. When operating the electronic device 30, a user can rotate the first housing 32 from a position as shown in FIG. 4 to a position as shown in FIG. 5 along a clockwise direction D1. Because the torque of the first pivoting mechanism 34 pivoting on the first end 401 is smaller than the torque of the second pivoting mechanism 38 pivoting on the second end 403, which means the torque for driving the second pivoting mechanism 38 is greater than the torque for driving the first pivoting mechanism 34, the user can not rotate the bridging component 40 around the second housing 36 when starting to push the first housing 32 to pivot on the bridging component 40. At this time, a bottom of the second housing 36 is placed on the supporting surface 48. As shown in FIG. 5, when the first housing 32 pivots on the second housing 36 at the first angle θ_1 along the clockwise direction D1, the side of the first housing 32 contacts against the first contacting portion 42 of the bridging component 40, which means the first housing 32 pivots on the bridging component 40 at the maximal angle. Meanwhile, the first angle θ_1 can be substantially 67.5 degrees.

When the first housing 32 rotates from the position as shown in FIG. 5 to a position as shown in FIG. 6 along the clockwise direction D1, because the first housing 32 can not pivot on the bridging component 40 anymore, the torque of the second pivoting mechanism 38 applied by the user must be greater than the torque of the first pivoting mechanism 34, so as to drive the second pivoting mechanism 38. Afterward, the first housing 32 presses the bridging component 40, so that the bending portion 46 of the bridging component 40 rotates around the supporting surface 48, so as to drive the second end 403 of the bridging component 40 to pivot on the second pivoting mechanism 38. Meanwhile, an end of the bending portion 46 contacts against the supporting surface 48 for arising the side of the second housing 36, then, the gap H is formed between the second housing 36 and the supporting surface 48. The gap H varies with the rotation angle of the bending portion 46 relative to the second housing 36. As shown in FIG. 6, when the first housing 32 pivots on the second housing 36 at the second angle θ_2 along the clockwise direction D1, the second contacting portion 44 of the bridging component 40 contacts against the side of the second housing 36, which means that is the maximum rotation angle of the bridging component 40 relative to the second housing 36. The second angle θ_2 can be substantially 135 degrees. At this time, there is the maximum height of the

5

side of the second housing 36 pushed by the bending portion 46 accordingly, and the third angle θ_3 is formed between the second housing 36 and the supporting surface 48. The third angle θ_3 can substantially be less than 5 degrees. Therefore, when the first housing 32 rotates around the second housing 36 at the second angle θ_2 along the clockwise direction D1, the second housing 36 is tilted for comfortable operation of the keyboard disposed on the second housing 36 at the third angle θ_3 . Besides, when the first housing 32 rotates around the second housing 36, the gap H formed between the second housing 36 and the supporting surface 48 can prevent the bottom of the second housing 36 from placing on the supporting surface 48 directly. Thus, the gap H can increase the heat convection space between the second housing 36 and the supporting surface 48 for increasing heat-dissipating efficiency of electronic components disposed inside the second housing 36.

Similar to the above-mentioned opening procedure, the closing procedure of the electronic device 30 is introduced as follows. Please refer to FIG. 2 and FIG. 7 to FIG. 9. FIG. 7 is a diagram of the electronic device 30 at the maximum opening angle according to one of the embodiments of the present invention. FIG. 8 is a diagram of the electronic device 30 in the closing process according to one of the embodiments of the present invention. FIG. 9 is a diagram of the closed electronic device 30 according to one of the embodiments of the present invention. The first housing 32 can pivot from a position as shown in FIG. 7 to a position as shown in FIG. 8 along a counterclockwise direction D2 when folding the electronic device 30. The torque of the second pivoting mechanism 38 pivoting on the second end 403 is greater than the torque of the first pivoting mechanism 34 pivoting on the first end 401. When the first housing 32 starts to pivot on the bridging component 40, the bridging component 40 does not rotate around the second housing 36, and the angle formed between the bridging component 40 and the supporting surface 48 keeps the third angle θ_3 until the side of the first housing 32 contacts against the first contacting portion 42 of the bridging component 40. When the first housing 32 pivots on the first end 401 at the first angle θ_1 along the counterclockwise direction D2, the side of the first housing 32 contacts against the first contacting portion 42 of the bridging component 40. Because the first housing 32 can not pivot on the bridging component 40 anymore, the user must apply a torque greater than the torque of the first pivoting mechanism 34 for driving the second pivoting mechanism 38. Meanwhile, the bending portion 46 can rotate around the second housing 36, so as to drive the second end 403 of the bridging component 40 to pivot on the second pivoting mechanism 38 at the second angle θ_2 along the counterclockwise direction D2, which means the first housing 32 can pivot from the position as shown in FIG. 6 (the dotted line as shown in the FIG. 8 and FIG. 9) to a position as shown in FIG. 9. The gap between the second housing 36 and the supporting surface 48 decreases accordingly, and the bottom of the second housing 36 is placed on the supporting surface 48 horizontally when the electronic device is folded completely. Thus, the electronic device 30 of the present invention can adjust the inclined angle between the second housing 36 and the supporting surface 48 according to the angle variation between the first housing 32 and the second housing 36.

Comparing to the prior art, the electronic device with a biaxial pivoting mechanism of the present invention can adjust the inclined angle between the second housing and the supporting surface according to the angle variation between the first housing and the second housing. The present

6

invention not only can adjust the inclined angle of the keyboard and the height of the liquid crystal display for comfortable operation, but also can form the gap between the housing and the supporting surface so as to increase the heat-dissipating efficiency of the electronic device.

Those skilled in the art will readily observe that numerous modifications and alterations of the device and method may be made while retaining the teachings of the invention.

What is claimed is:

1. An electronic device comprising:

a first housing;

a first pivoting mechanism disposed on a side of the first housing;

a second housing;

a second pivoting mechanism disposed on a side of the second housing; and

a bridging component, a first end and a second end of the bridging component being respectively pivoted on the first pivoting mechanism and the second pivoting mechanism, the bridging component comprising:

a first contacting portion [for contacting] configured to contact against the side of the first housing [when the first pivoting mechanism pivots on the first end so that] at a position where the first housing rotates around the second housing [at] to a first angle as the first pivoting mechanism pivots on the first end; and

a second contacting portion [for contacting] configured to contact against the side of the second housing [when the second end pivots on the second pivoting mechanism so that] at another position where the first housing rotates around the second housing [at] to a second angle greater than the first angle as the second pivoting mechanism pivots on the second end, wherein the bridging component comprises a bending portion connected between the first contacting portion and the second contacting portion.

2. The electronic device of claim 1, wherein a torque of the first pivoting mechanism pivoting on the first end is smaller than a torque of the second pivoting mechanism pivoting on the second end.

3. The electronic device of claim 1, wherein [the bridging component comprises a bending portion connected to the first contacting portion and the second contacting portion and disposed on a supporting surface, and the bending portion rotates] after the side of the first housing contacts against the first contacting portion of the bridging component, the bending portion is configured to contact against and rotate around [the] a supporting surface whereon the electronic device is disposed to drive the second end of the bridging component to pivot on the second pivoting mechanism so that a gap is formed between the second housing and the supporting surface [when the side of the first housing contacts against the first contacting portion of the bridging component].

4. The electronic device of claim 3, wherein a third angle is formed between the second housing and the supporting surface when the side of the second housing contacts against the second contacting portion of the bridging component.

5. The electronic device of claim 4, wherein the third angle is substantially less than 5 degrees.

6. The electronic device of claim 3, wherein the bridging component is a U-shaped structure.

7. The electronic device of claim 1, wherein the first angle is substantially 67.5 degrees.

8. The electronic device of claim 1, wherein the second angle is substantially 135 degrees.

7

9. The electronic device of claim 1 further comprising:
a covering component [for covering] configured to cover
the bridging component.

10. The electronic device of claim 9 further comprising:
a buffer disposed on an outer side of the covering com- 5
ponent [for preventing] to prevent abrasion of the
covering component.

11. A biaxial pivoting mechanism, adopted to an elec-
tronic device having a first housing and a second housing
pivoted to the first housing therewith, comprising:

a first pivoting mechanism adopted to be disposed on a 10
side of the first housing;

a second pivoting mechanism adopted to be disposed on
a side of the second housing; and

a bridging component, having a first end and a second 15
end respectively pivoted on the first pivoting mecha-
nism and the second pivoting mechanism, and further
having a first contacting portion and a second contact-
ing portion respectively adjacent to the first end and the
second end;

wherein the bridging component comprises a bending 20
portion connected between the first contacting portion
and the second contacting portion, when the first piv-
oting mechanism and the second pivoting mechanism
are respectively disposed on the side of the first housing

8

and the side of the second housing, the first contacting
portion is configured to contact against the side of the
first housing at a position where the first housing
rotates around the second housing to a first angle and
the second contacting portion is configured to contact
against the side of the second housing at another
position where the first housing rotates around the
second housing to a second angle greater than the first
angle.

12. The biaxial pivoting mechanism of claim 11, wherein
a torque of the first pivoting mechanism pivoting on the first
end is smaller than a torque of the second pivoting mecha-
nism pivoting on the second end.

13. The biaxial pivoting mechanism of claim 11, wherein
the bridging component is a U-shaped structure.

14. The biaxial pivoting mechanism of claim 11, further
comprising:

a covering component configured to cover the bridging
component.

15. The biaxial pivoting mechanism of claim 14, further
comprising:

a buffer disposed on an outer side of the covering com-
ponent to prevent abrasion of the covering component.

* * * * *