

US00RE46083E

(19) **United States**
(12) **Reissued Patent**
Little et al.

(10) **Patent Number:** **US RE46,083 E**
(45) **Date of Reissued Patent:** **Jul. 26, 2016**

(54) **SYSTEM AND METHOD FOR HANDLING DATA TRANSFERS**

(71) Applicant: **BlackBerry Limited**, Waterloo (CA)

(72) Inventors: **Herbert Anthony Little**, Waterloo (CA);
Neil Patrick Adams, Waterloo (CA);
Michael Grant Kirkup, Waterloo (CA)

(73) Assignee: **BlackBerry Limited**, Waterloo, ON (CA)

(21) Appl. No.: **14/163,416**

(22) Filed: **Jan. 24, 2014**

Related U.S. Patent Documents

Reissue of:

(64) Patent No.: **8,005,469**
Issued: **Aug. 23, 2011**
Appl. No.: **12/795,252**
Filed: **Jun. 7, 2010**

U.S. Applications:

(63) Continuation of application No. 13/490,956, filed on Jun. 7, 2012, now Pat. No. Re. 44,746, which is an application for the reissue of Pat. No. 8,005,469, which is a continuation of application No. 11/118,791, filed on Apr. 29, 2005, now Pat. No. 7,734,284.

(60) Provisional application No. 60/567,293, filed on Apr. 30, 2004.

(51) **Int. Cl.**
H04M 3/00 (2006.01)
G06F 17/00 (2006.01)
H04L 29/06 (2006.01)
H04W 12/08 (2009.01)
H04M 7/00 (2006.01)
H04W 12/02 (2009.01)
H04L 12/58 (2006.01)
H04M 3/20 (2006.01)

(52) **U.S. Cl.**
CPC **H04L 63/04** (2013.01); **H04L 12/5855** (2013.01); **H04L 51/14** (2013.01); **H04L 63/105** (2013.01); **H04M 7/0078** (2013.01); **H04W 12/02** (2013.01); **H04W 12/08** (2013.01); **H04L 12/5895** (2013.01); **H04M 3/205** (2013.01); **H04M 2203/609** (2013.01)

(58) **Field of Classification Search**
None
See application file for complete search history.

(56) **References Cited**

U.S. PATENT DOCUMENTS

4,815,128 A 3/1989 Malek
4,837,812 A 6/1989 Takahashi et al.

(Continued)

FOREIGN PATENT DOCUMENTS

CA 2505343 6/2010
CN 101253487 8/2008

(Continued)

OTHER PUBLICATIONS

Office Action issued in U.S. Appl. No. 13/529,509 on Mar. 25, 2014.

(Continued)

Primary Examiner — Minh Dieu Nguyen
(74) *Attorney, Agent, or Firm* — Fish & Richardson P.C.

(57) **ABSTRACT**

Systems and methods for managing data transfers between a secure location and a less secure location. A data transfer checker operating on a mobile device determines whether an attempted data transfer between two locations is permitted. If it is not permitted, then the data transfer is prevented and the user may be notified of the data transfer prevention.

15 Claims, 11 Drawing Sheets

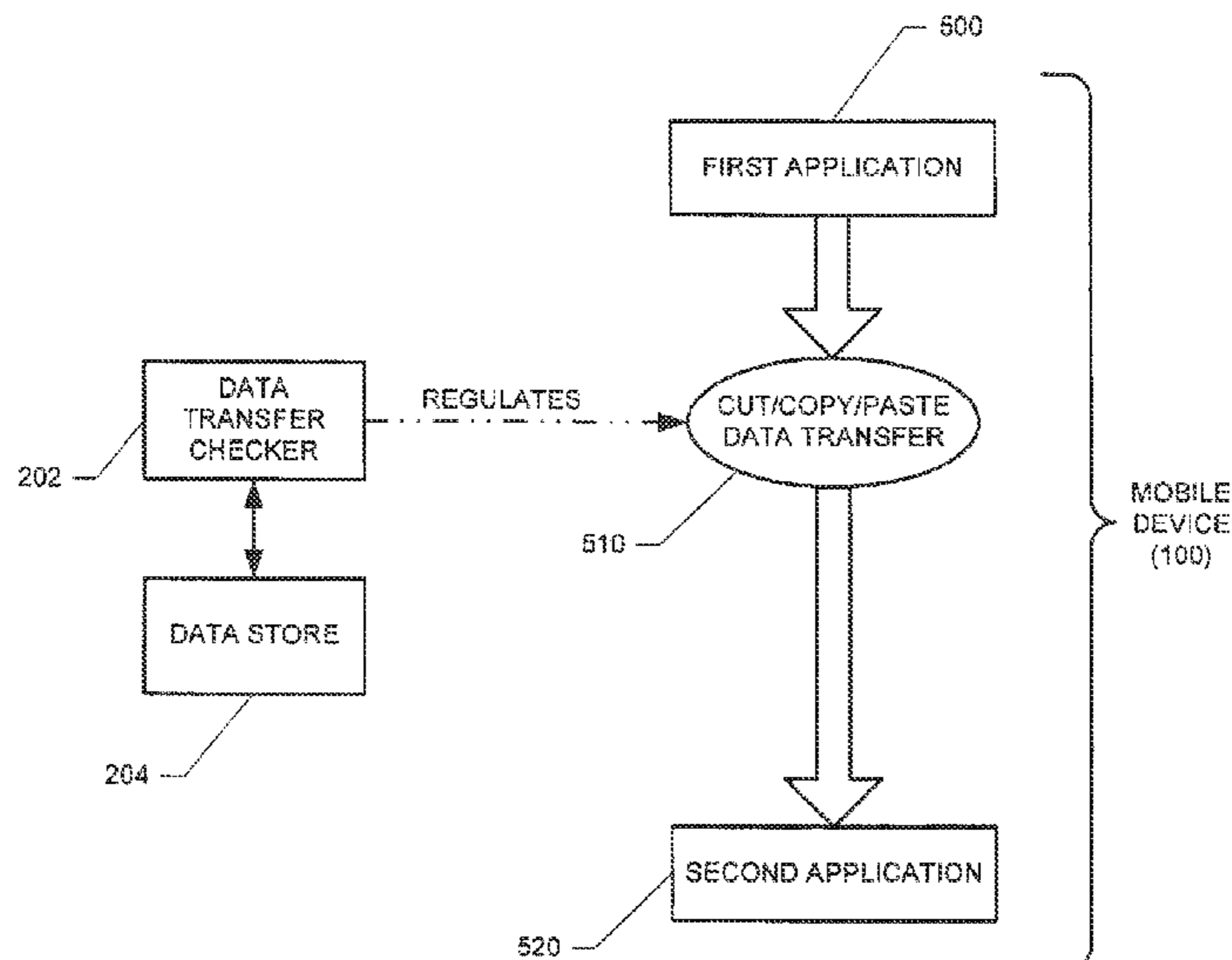

(56)

References Cited

U.S. PATENT DOCUMENTS

4,945,556	A	7/1990	Namekawa	7,921,452	B2	4/2011	Ridlon et al.
4,972,457	A	11/1990	O'Sullivan	8,005,469	B2	8/2011	Adams et al.
4,991,197	A	2/1991	Morris	8,074,078	B2	12/2011	Brown et al.
5,220,604	A	6/1993	Gasser et al.	8,208,900	B2	6/2012	Adler et al.
5,408,520	A	4/1995	Clark et al.	8,495,700	B2	7/2013	Shahbazi
5,606,594	A	2/1997	Register et al.	8,495,731	B1	7/2013	Mar et al.
5,774,551	A	6/1998	Wu et al.	8,503,340	B1	8/2013	Xu
5,802,483	A	9/1998	Morris	8,588,749	B1	11/2013	Sadhvani
5,826,265	A	10/1998	Van Huben et al.	8,656,016	B1	2/2014	Bender et al.
5,850,515	A	12/1998	Lo et al.	8,931,042	B1	1/2015	Weiss
5,864,765	A	1/1999	Barvesten	2001/0047485	A1	11/2001	Brown et al.
5,987,440	A	11/1999	O'Neil et al.	2001/0056549	A1	12/2001	Pinault et al.
5,987,611	A	11/1999	Freund	2002/0013815	A1	1/2002	Obradovich et al.
6,052,735	A	4/2000	Ulrich et al.	2002/0019944	A1	2/2002	Kou
6,088,693	A	7/2000	Van Huben et al.	2002/0029280	A1*	3/2002	Holden et al. 709/229
6,105,132	A	8/2000	Fritch et al.	2002/0031230	A1	3/2002	Yu et al.
6,125,447	A	9/2000	Gong	2002/0087880	A1	7/2002	Rhoades
6,131,136	A	10/2000	Liebenow et al.	2002/0095414	A1	7/2002	Barnett et al.
6,219,694	B1	4/2001	Lazaridis et al.	2002/0095497	A1	7/2002	Satagopan et al.
6,233,446	B1	5/2001	Do	2002/0095571	A1	7/2002	Bradee
6,243,756	B1	6/2001	Whitmire et al.	2002/0112155	A1	8/2002	Martherus et al.
6,253,326	B1	6/2001	Lincke et al.	2002/0184398	A1	12/2002	Orenshteyn
6,285,889	B1	9/2001	Nykanen et al.	2003/0005317	A1	1/2003	Audebert et al.
6,292,798	B1	9/2001	Dockter et al.	2003/0014521	A1	1/2003	Elson et al.
6,343,313	B1	1/2002	Salesky et al.	2003/0026220	A1	2/2003	Uhlik et al.
6,351,816	B1	2/2002	Mueller et al.	2003/0031184	A1	2/2003	Cunetto et al.
6,360,322	B1	3/2002	Grawrock	2003/0035397	A1	2/2003	Haller et al.
6,405,202	B1	6/2002	Britton et al.	2003/0054860	A1	3/2003	Chen
6,408,336	B1*	6/2002	Schneider et al. 709/229	2003/0061087	A1	3/2003	Srimuang
6,412,070	B1	6/2002	Van Dyke et al.	2003/0065676	A1	4/2003	Gbadegesin et al.
6,490,289	B1	12/2002	Zhang et al.	2003/0070091	A1	4/2003	Loveland
6,516,421	B1	2/2003	Peters	2003/0087629	A1	5/2003	Juitt et al.
6,546,554	B1	4/2003	Schmidt et al.	2003/0093698	A1	5/2003	Challener et al.
6,647,388	B2	11/2003	Numao et al.	2003/0120948	A1	6/2003	Schmidt et al.
6,668,323	B1	12/2003	Challener et al.	2003/0126437	A1	7/2003	Wheeler et al.
6,745,047	B1	6/2004	Karstens et al.	2003/0163685	A1	8/2003	Paatero
6,748,543	B1	6/2004	Vilhuber	2003/0167405	A1	9/2003	Freund et al.
6,757,821	B1	6/2004	Akiyama et al.	2003/0177389	A1	9/2003	Albert et al.
6,772,350	B1	8/2004	Belani et al.	2003/0226015	A1	12/2003	Neufeld et al.
6,775,536	B1	8/2004	Geiger et al.	2003/0233410	A1	12/2003	Gusler
6,785,810	B1	8/2004	Lirov et al.	2003/0236983	A1	12/2003	Mihm, Jr.
6,795,688	B1	9/2004	Plasson et al.	2004/0001101	A1	1/2004	Trajkovic et al.
6,795,967	B1	9/2004	Evans et al.	2004/0083382	A1*	4/2004	Markham et al.
6,832,256	B1*	12/2004	Toga 709/229	2004/0097217	A1	5/2004	McClain
6,886,038	B1	4/2005	Tabbara et al.	2004/0100983	A1*	5/2004	Suzuki
6,895,502	B1	5/2005	Fraser et al.	2004/0121802	A1	6/2004	Kim et al.
6,901,429	B2	5/2005	Dowling	2004/0177073	A1	9/2004	Snyder et al.
6,957,330	B1	10/2005	Hughes	2004/0209608	A1*	10/2004	Kouznetsov et al.
6,976,241	B2	12/2005	Cruz et al.	2004/0215702	A1	10/2004	Hamasaki et al.
6,978,385	B1	12/2005	Cheston et al.	2004/0260710	A1	12/2004	Marston
6,999,562	B2	2/2006	Winick	2004/0268151	A1*	12/2004	Matsuda 713/201
7,042,988	B2	5/2006	Juitt et al.	2005/0022023	A1*	1/2005	Chincheck et al. 713/201
7,076,239	B2	7/2006	Kirkup et al.	2005/0154935	A1	7/2005	Jin
7,076,797	B2	7/2006	Loveland	2005/0164687	A1*	7/2005	DiFazio
7,146,638	B2	12/2006	Malcolm	2005/0192008	A1	9/2005	Desai et al.
7,185,192	B1*	2/2007	Kahn 713/155	2005/0210270	A1	9/2005	Rohatgi et al.
7,187,678	B2	3/2007	Cunetto et al.	2005/0213763	A1	9/2005	Owen et al.
7,246,374	B1	7/2007	Simon et al.	2005/0245272	A1*	11/2005	Spaur et al.
7,315,750	B2	1/2008	Chou et al.	2006/0015621	A1	1/2006	Quinn
7,330,712	B2	2/2008	Kirkup et al.	2006/0059556	A1	3/2006	Royer
7,331,058	B1	2/2008	Gladney	2006/0070114	A1	3/2006	Wood et al.
7,400,878	B2	7/2008	Hassan et al.	2006/0090136	A1	4/2006	Miller et al.
7,469,417	B2	12/2008	Fearnley et al.	2006/0120526	A1	6/2006	Boucher et al.
7,526,800	B2	4/2009	Wright et al.	2006/0129848	A1*	6/2006	Paksoy et al.
7,574,200	B2	8/2009	Hassan et al.	2006/0129948	A1	6/2006	Hamzy et al.
7,603,466	B2	10/2009	Kilian-Kehr et al.	2006/0149846	A1	7/2006	Schuba
7,721,087	B1	5/2010	DiPasquo et al.	2006/0156026	A1	7/2006	Utin
7,734,284	B2	6/2010	Adams et al.	2006/0168259	A1	7/2006	Spilotro et al.
7,751,331	B1	7/2010	Blair et al.	2006/0168395	A1	7/2006	Deng et al.
7,765,185	B2	7/2010	Rangadass	2006/0206931	A1	9/2006	Dillaway et al.
7,793,355	B2	9/2010	Little et al.	2006/0212589	A1	9/2006	Hayer et al.
7,869,789	B2	1/2011	Hassan et al.	2006/0242685	A1	10/2006	Heard et al.
7,886,053	B1	2/2011	Newstadt et al.	2006/0274750	A1	12/2006	Babbar et al.
7,890,627	B1	2/2011	Thomas	2007/0019643	A1	1/2007	Sahheen
7,917,963	B2	3/2011	Goyal et al.	2007/0050854	A1	3/2007	Cooperstein et al.
				2007/0073694	A1	3/2007	Picault et al.
				2007/0156766	A1	7/2007	Hoang et al.
				2007/0204153	A1	8/2007	Tome et al.
				2007/0204166	A1	8/2007	Tome et al.

(56)

References Cited

U.S. PATENT DOCUMENTS

2007/0254631 A1 11/2007 Spooner
 2007/0277127 A1 11/2007 Carlson et al.
 2008/0002726 A1 1/2008 Haung et al.
 2008/0028442 A1 1/2008 Kaza et al.
 2008/0081609 A1 4/2008 Burgan et al.
 2008/0098237 A1 4/2008 Dung et al.
 2008/0125146 A1 5/2008 Bainbridge
 2008/0130524 A1 6/2008 Volach et al.
 2008/0132202 A1 6/2008 Kirkup et al.
 2008/0134347 A1 6/2008 Goyal et al.
 2008/0137593 A1 6/2008 Laudermilch et al.
 2008/0184336 A1 7/2008 Sarukki et al.
 2008/0222711 A1 9/2008 Michaelis
 2008/0235041 A1 9/2008 Cashdollar et al.
 2008/0318616 A1 12/2008 Chipalkatti et al.
 2009/0031393 A1 1/2009 Denner
 2009/0068996 A1 3/2009 Bakker et al.
 2009/0070181 A1 3/2009 Loeffen
 2009/0094668 A1 4/2009 Corbin et al.
 2009/0178107 A1 7/2009 Karjoth et al.
 2009/0181662 A1 7/2009 Fleischman et al.
 2009/0254753 A1 10/2009 De Atley et al.
 2009/0260052 A1 10/2009 Bathula et al.
 2009/0300707 A1 12/2009 Garimella et al.
 2010/0024016 A1 1/2010 Violleau et al.
 2010/0024020 A1 1/2010 Baugher et al.
 2010/0081417 A1 4/2010 Hickie
 2010/0088753 A1 4/2010 Ayres et al.
 2010/0100825 A1 4/2010 Sharoni
 2010/0107215 A1 4/2010 Bechtel et al.
 2010/0153969 A1 6/2010 Dyba et al.
 2010/0175104 A1 7/2010 Khalid
 2010/0184440 A1 7/2010 Mao et al.
 2010/0222097 A1 9/2010 Gisby et al.
 2010/0242086 A1 9/2010 Adams et al.
 2010/0274910 A1 10/2010 Ghanaie-Sichanie et al.
 2010/0278162 A1 11/2010 Groux et al.
 2010/0281487 A1 11/2010 Schneider et al.
 2010/0299376 A1 11/2010 Batchu et al.
 2010/0299394 A1 11/2010 Jania et al.
 2010/0299719 A1 11/2010 Burks et al.
 2010/0319053 A1 12/2010 Gharabally
 2010/0325221 A1 12/2010 Cohen et al.
 2010/0325430 A1 12/2010 Denninghoff
 2010/0325710 A1 12/2010 Etchegoyen
 2011/0010699 A1 1/2011 Cooper et al.
 2011/0082808 A1 4/2011 Beykpour et al.
 2011/0099605 A1 4/2011 Cha et al.
 2011/0126214 A1 5/2011 O'Farrell et al.
 2011/0145833 A1 6/2011 De Los Reyes et al.
 2011/0179083 A1 7/2011 Galloway et al.
 2011/0195698 A1 8/2011 Pearce
 2011/0210171 A1 9/2011 Brown et al.
 2011/0246753 A1 10/2011 Thomas
 2011/0252240 A1 10/2011 Freedman et al.
 2011/0270963 A1 11/2011 Saito et al.
 2011/0314467 A1 12/2011 Pearson
 2012/0005477 A1 1/2012 Wei et al.
 2012/0005723 A1 1/2012 Chaturvedi et al.
 2012/0005745 A1 1/2012 Wei et al.
 2012/0023573 A1 1/2012 Shi
 2012/0054853 A1 3/2012 Gupta et al.
 2012/0079110 A1 3/2012 Brown et al.
 2012/0079586 A1 3/2012 Brown et al.
 2012/0079609 A1 3/2012 Bender et al.
 2012/0084184 A1 4/2012 Raleigh et al.
 2012/0109826 A1 5/2012 Kobres
 2012/0131685 A1 5/2012 Broch et al.
 2012/0144196 A1 6/2012 Owen et al.
 2012/0157165 A1 6/2012 Kim et al.
 2012/0157166 A1 6/2012 Kim et al.
 2012/0202527 A1 8/2012 Obradovich et al.
 2012/0210443 A1 8/2012 Blaisdell et al.
 2012/0214442 A1 8/2012 Crawford et al.
 2012/0214503 A1 8/2012 Liu et al.

2012/0278863 A1 11/2012 Wallace et al.
 2012/0278904 A1 11/2012 Perez et al.
 2012/0291140 A1 11/2012 Robert et al.
 2012/0304280 A1 11/2012 Hayashida
 2012/0309344 A1 12/2012 Ferrazzini et al.
 2012/0324067 A1 12/2012 Hari et al.
 2013/0074142 A1 3/2013 Brennan et al.
 2013/0097316 A1 4/2013 Bender et al.
 2013/0097657 A1 4/2013 Cardamore et al.
 2013/0124583 A1 5/2013 Ferguson et al.
 2013/0174222 A1 7/2013 Ogle
 2013/0219465 A1 8/2013 Tse et al.
 2013/0346606 A1 12/2013 Ryerson et al.

FOREIGN PATENT DOCUMENTS

CN 101523878 9/2009
 EP 332558 9/1989
 EP 605106 7/1994
 EP 973350 1/2000
 EP 1168141 1/2002
 EP 1471691 10/2004
 EP 1596410 11/2005
 EP 1624428 2/2006
 EP 1806674 7/2007
 EP 1563663 10/2008
 EP 2337300 6/2011
 GB 2378780 2/2003
 GB 2408179 5/2005
 GB 2440015 1/2008
 JP 2000-253241 9/2000
 JP 2001-077811 3/2001
 JP 2001-203761 * 7/2001
 JP 2002-288087 * 10/2002
 WO 96/25828 8/1996
 WO 99/05814 * 2/1999
 WO 00/59225 10/2000
 WO 00/60434 10/2000
 WO 2004/017592 2/2004
 WO 2004/043031 5/2004
 WO 2005/045550 5/2005
 WO 2005/062279 7/2005
 WO 2006/130807 12/2006
 WO 2007/048251 5/2007
 WO 2009/012329 1/2009
 WO 2009/014975 1/2009
 WO 2009/021200 2/2009
 WO 2012/037656 3/2012
 WO 2012/037657 3/2012
 WO 2012/037658 3/2012
 WO 2012/109497 8/2012

OTHER PUBLICATIONS

International Preliminary Report on Patentability under Ch. II issued in International Application No. PCT/CA2012/050796 on Mar. 10, 2014; 18 pages.
 Office Action issued in U.S. Appl. No. 13/293,743 on Jul. 16, 2014.
 Office Action issued in U.S. Appl. No. 13/274,913 on Jul. 1, 2014.
 Office Action issued in U.S. Appl. No. 13/25,097 on Jul. 16, 2014.
 Office Action issued in U.S. Appl. No. 13/659,561 on Jul. 2, 2014.
 Extended European Search Report mailed Mar. 17, 2014 in European Application No. 11162178.5.
 Office Action issued in Chinese Application No. 201110308441.4 on Jul. 8, 2014; 4 pages. No translation.
 Communication Pursuant to Article 94(3) EPC issued in European Application No. 11186796.6 on Aug. 29, 2014; 5 pages.
 Office Action issued in Canadian Application No. 2,792,772 on Sep. 5, 2014; 3 pages.
 Office Action issued in Canadian Application No. 2,792,707 on Sep. 8, 2014; 3 pages.
 Office Action issued in U.S. Appl. No. 13/296,963 on Oct. 3, 2014.
 Notice of Acceptance issued in Australian Application No. 2012203391 on Jul. 25, 2014; 2 pages.
 Communication pursuant to Article 94(3) issued in EP Application No. 11186802.2 on Aug. 25, 2014.

(56)

References Cited

OTHER PUBLICATIONS

International Preliminary Report on Patentability under Chapter II issued in International Application No. PCT/CA2012/050797 on Feb. 12, 2014; 13 pages.

IETF RFC 3530; "Network File System (NFS) Version 4 Protocol"; Apr. 2003.

"Secure Inter-Process Communication"; Apr. 4, 2004. Retrieved from internet on Jan. 20, 2014 <https://web.archive.org/web/20040404015137/http://cr.yip.to/docs/secureipc.html>.

Notice of Allowance issued in Canadian Application No. 2,769,646 on Feb. 15, 2013; 1 page.

Office Action issued in Canadian Application No. 2,564,914 on Dec. 3, 2013; 2 pages.

Notice of Allowance. Canadian Application No. 2,505,343. Dated: Sep. 15, 2009.

Examiner's First Report issued in Australian Application No. 2012203391 on Jan. 22, 2014; 4 pages.

Office Action issued in Chinese Application No. 201110308441.4 on Oct. 25, 2013; 9 pages.

Office Action issued in U.S. Appl. No. 13/274,913 on Dec. 5, 2014.

Office Action issued in Canadian Application No. 2,820,687 on Nov. 3, 2014; 3 pages.

Office Action issued in U.S. Appl. No. 13/659,561 on Dec. 10, 2014. XP002167366; Chen, Zhijun; "Java Card Technology for Smart Cards: Architecture and Programmer's Guide"; "Applet Firewall and Object Sharing;" Internet citation; Jun. 2, 2000; <<http://developer.java.sun.com/developer/Books/consumerproducts/javacard/ch09.pdf>>.

Google Inc.; Android 2.3.4 User's Guide; May 20 2011; 384 pages. Microsoft Corp.; Microsoft Outlook 2010; Released Jul. 15, 2010; 27 pages.

Microsoft Office: Microsoft Outlook 2010 Product Guide; Microsoft Corp. 2010; published in 2010; 65 pages.

Windows 7 Product Guide; Microsoft Corp. 2009; published in 2009; 140 pages.

Research in Motion, "BlackBerry Bridge App 2.1 and Blackberry PlayBook Tablet 2.1, Security Technical Overview"; Version: 2.1; Jul. 17, 2012; 43 pages.

Research in Motion, "BlackBerry Device Service 6.1 and BlackBerry PlayBook Tablet 2.1, Security Technical Overview"; Version: 6.1; Sep. 17, 2012; 90 pages.

View messages with restricted permission sent by using IRM; Support/Outlook/Outlook 2007 Help and How-to. <http://office.microsoft.com/en-us/outlook-help/view-messages-with-restricted-permission-sent-by-using-irm-HA010246115.aspx> . . . , pp. 1-2, retrieved on Feb. 12, 2010.

Send an e-mail message with restricted permission by using IRM; Support/Outlook/Outlook 2007 Help and How to. <http://office.microsoft.com/en-us/outlook-help/send-an-e-mail-message-with-restricted-permission-by-using-irm-HA01024780.aspx> . . . , pp. 1-4, retrieved on Feb. 12, 2010.

Introduction to using IRM for e-mail messages; Support/Outlook/Outlook 2007 Help and How-to. <http://office.microsoft.com/en-us/outlook-help/introduction-to-using-irm-for-e-mail-message-HA010100366.aspx?CTT=5&or> . . . , pp. 1-6, retrieved on Feb. 12, 2010.

Red Hat: "Red Hat Linux 7.2—The Official Red Hat Linux Reference Guide" Red Hat Linux Manuals, Online!, Oct. 22, 2001, XP002276029, pp. 145-155.

Sygate: "Sygate Personal Firewall PRO User Guide" Sygate Personal Firewall Pro User Guide version 2.0; 2001, pp. 1-77, XP002248366. "A Technical Overview of the Lucent VPN Firewall" White Paper Lucent Technologies, XX, XX, Aug. 2002, pp. 1-35, XP002271173, Chapter 1.

"Customizing User Interaction in Smart Phones", Pervasive Computing, IEEE CS (2006) pp. 81-90 (URL: <http://www.idi.ntnu.no/grupperlsu/bibliography/pdf/2006/Korpipaa2006pc.pdf>).

"Supporting Mobile Privacy and Security through Sensor-Based Context Detection", Julian Seifert, Second International Workshop on Security and Privacy in Spontaneous Interaction and Mobile

Phone Use, May 17, 2010, Finland (URL: <http://www.medien.fhnw.de/iwssi2010/papers/iwssi-spmu2010-seifert.pdf>).

EagleVision: A Pervasive Mobile Device Protection System, Ka Yang, Nalin Subramanian, Daji Qiao, and Wen sheng Zhang, Iowa State University (URL: <http://www.cs.iastate.edu/~wzhang/papers/eagleVision.pdf>) Jul. 13-16, 2009.

"Using context-profiling to aid access control decisions in mobile devices", Gupta et al., Nokia Research Center (URL: <http://www.cerias.purdue.edu/assets/symposium/2011-posters1372-C48.pdf>)

Please refer to the I-page file named 372-C48.pdf; 2011.

Smartphone Security Beyond Lock and Wipe (Jun. 10, 2010): <http://www.enterprisemobiletoday.com/article.php/3887006>.

Basic Access Authentication (Jan. 23, 2010): http://en.wikipedia.org/wiki/Basic_access_authentication.

Digest Access Authentication (Dec. 23, 2009): http://en.wikipedia.org/wiki/Digest_access_authentication.

Cross-site request forgery (Nov. 30, 2008): http://en.wikipedia.org/wiki/Cross-site_request_forgery.

Office Action issued in U.S. Appl. No. 11/118,791 on Sep. 25, 2006; 11 pages.

Office Action issued in U.S. Appl. No. 11/118,791 on Nov. 28, 2007; 12 pages.

Office Action issued in U.S. Appl. No. 11/118,791 on Mar. 30, 2007; 12 pages.

Office Action issued in U.S. Appl. No. 11/118,791 on May 20, 2008; 13 pages.

Office Action issued in U.S. Appl. No. 11/118,791 on Jan. 27, 2009; 16 pages.

Office Action issued in U.S. Appl. No. 11/118,791 on Apr. 8, 2009; 14 pages.

Advisory Action issued in U.S. Appl. No. 11/118,791 on Jun. 26, 2009; 8 pages.

Notice of Allowance issued in U.S. Appl. No. 11/118,791 on Jan. 20, 2010; 4 pages.

Office Action issued in U.S. Appl. No. 12/795,252 on Aug. 6, 2010; 6 pages.

Notice of Allowance issued in U.S. Appl. No. 12/795,252 on Dec. 17, 2010; 4 pages.

Notice of Allowance issued in U.S. Appl. No. 12/795,252 on Apr. 14, 2011; 4 pages.

Notice of Allowance issued in U.S. Appl. No. 13/490,956 on Dec. 4, 2013; 8 pages.

Office Action issued in U.S. Appl. No. 13/296,963 on Nov. 18, 2013; 23 pages.

Ferguson et al., U.S. Appl. No. 13/293,743, "Managing Cross Perimeter Access," filed Nov. 10, 2011.

Office Action issued in U.S. Appl. No. 13/293,743 on Feb. 14, 2013; 15 pages.

Office Action issued in U.S. Appl. No. 13/293,743 on Sep. 20, 2013; 19 pages.

Advisory Action issued in U.S. Appl. No. 13/293,743 on Nov. 26, 2013; 3 pages.

Office Action issued in U.S. Appl. No. 13/398,676 on Sep. 5, 2012; 21 pages.

Notice of Allowance issued in U.S. Appl. No. 13/398,676 on Nov. 7, 2013; 22 pages.

Office Action issued in U.S. Appl. No. 13/274,913 on Jan. 23, 2013; 22 pages.

Office Action issued in U.S. Appl. No. 13/274,913 on Jul. 16, 2013.

Office Action issued in U.S. Appl. No. 13/274,913 on Jan. 2, 2014.

Office Action issued in U.S. Appl. No. 13/25,097 on Feb. 28, 2013; 18 pages.

Advisory Action issued in U.S. Appl. No. 13/275,097 on Dec. 6, 2013; 4 pages.

Office Action issued in U.S. Appl. No. 13/25,097 on Sep. 10, 2013; 21 pages.

Office Action issued in U.S. Appl. No. 13/659,527 on May 23, 2013; 8 pages.

Notice of Allowance issued in U.S. Appl. No. 13/659,527 on Oct. 7, 2013; 15 pages.

Office Action issued in U.S. Appl. No. 13/722,213 on May 22, 2013; 8 pages.

(56)

References Cited

OTHER PUBLICATIONS

Office Action issued in U.S. Appl. No. 13/722,213 on Dec. 4, 2013; 6 pages.

Notice of Allowance issued in U.S. Appl. No. 13/722,213 on Jan. 29, 2014; 7 pages.

Office Action issued in U.S. Application No. 10/524,353 on Sep. 21, 2012; 16 pages.

Office Action issued in U.S. Appl. No. 13/098,456 on Sep. 13, 2012; 20 pages.

Office Action issued in U.S. Appl. No. 13/098,456 on Apr. 17, 2013; 31 pages.

Office Action issued in U.S. Appl. No. 13/098,456 on Sep. 27, 2013; 28 pages.

Owen, Russell N., U.S. Appl. No. 13/371,093, filed Feb 10, 2012; Title: System and Method for Secure Control of Resources of Wireless Mobile Communication Device.

Owen, Russell N., U.S. Appl. No. 10/524,353, filed Aug. 19, 2003; Title: System and Method for Secure Control of Resources of Wireless Mobile Communication Devices.

Office Action issued in U.S. Appl. No. 10/524,353 on Sep. 21, 2012.

Owen, Russell N., U.S. Appl. No. 10/524,353, filed Feb. 14, 2005; Title: System and Method for Secure Control of Resources of Wireless Mobile Communication Device.

Bender, Christopher Lyle; U.S. Appl. No. 13/074,136, filed Mar. 29, 2011; Title: Data Source Based Application Sandboxing.

Extended European Search Report issued in European Application No. 11188696.6 on Apr. 12, 2012; 7 pages.

Communication Pursuant to Article 94(3) EPC issued in European Application No. 11188696.6 on Jul. 9, 2013; 4 pages.

Extended European Search Report issued in European Application No. 11186802.2 on Jan. 18, 2012; 7 pages.

Extended European Search Report issued in European Application No. 11186796.6 on Jan. 18, 2012; 8 pages.

Extended European Search Report issued in European Application No. 12173030.3 on Nov. 22, 2012; 6 pages.

Extended European Search Report issued in European Application No. 12189773.0 on Mar. 7, 2013; 8 pages.

Extended European Search Report issued in European Application No. 12189805.0 on Apr. 16, 2013; 6 pages.

European Supplementary Search Report issued in European Application No. 05738877.9 on Sep. 13, 2007; 3 pages.

Communication Pursuant to Article 94(3) EPC issued in European Application No. 05738877.9 on Jan. 15, 2008; 4 pages.

Communication Pursuant to Article 94(3) Epc issued in European Application No. 05738877.9 on Jul. 15, 2009; 4 pages.

Communication under Rule 71(3) EPC issued in European Application No. 05738877.9 on Sep. 17, 2010; 41 pages.

EP Application No. 12155659.1, Extended European Search Report dated Jan. 8, 2012.

Extended European Search Report mailed Jul. 13, 2012, in corresponding European patent application No. 12153439.0.

European Search Report of Appln. No. 04256690.1-2412, date of mailing Apr. 6, 2005—9 pgs.

International Search Report and Written Opinion of the International Searching Authority issued in International Application No. PCT/CA2012/050796 on Feb. 21, 2013; 13 pages.

International Search Report and Written Opinion issued in International Application No. PCT/CA2011/001058 on Dec. 21, 2011; 9 pages.

International Search Report and Written Opinion issued in International Application No. PCT/CA2012/050797 on Feb. 5, 2013; 8 pages.

International Search Report and Written Opinion of the International Searching Authority issued in International Application No. PCT/CA2011/050707 on Jan. 18, 2012; 7 pages.

International Preliminary Report on Patentability issued in International Application No. PCT/CA2011/050707 on May 30, 2013; 4 pages.

International Search Report issued in International Application No. PCT/CA2005/000652 on Aug. 17, 2005; 9 pages.

International Preliminary Report on Patentability under Chapter I issued in International Application No. PCT/CA2005/000652 on Nov. 9, 2006; 6 pages.

International Application No. PCT/CA 03101245, International Search Report dated Dec. 23, 2003.

International Application No. PCT/CA 03101245, PCT Written Opinion, dated Apr. 23, 2004.

International Application No. PCT/CA 03101245, PCT Written Opinion, dated Sep. 20, 2004.

International Application No. PCT/CA 03101245, PCT International Preliminary Examination Report, dated Nov. 29, 2004.

Int'l Search Report and the Written Opinion of the Int'l Searching Authority, or the Declaration of Appln. Serial No. PCT/CA2004/000250 of Feb. 20, 2004—12 pgs.

International Search Report issued in International Application No. PCT/CA03/01679 on May 6, 2004—6 pgs.

Office Action issued in Canadian Application No. 2,769,646 on Jun. 5, 2012; 3 pages.

Office Action issued in Canadian Application No. 2,769,646 on Oct. 22, 2012; 2 pages.

Office Action issued in Canadian Application No. 2,564,914 on May 3, 2010; 4 pages.

Office Action issued in Canadian Application No. 2,564,914 on Apr. 4, 2011; 2 pages.

Examiner's First Report issued in Australian Application No. 2005239005 on Oct. 15, 2007; 2 pages.

Examiner's Report No. 2 issued in Australian Application No. 2005239005 on Jul. 15, 2009; 2 pages.

Examiner's First Report issued in Australian Application No. 2009202857 on Nov. 5, 2010; 3 pages.

First Office Action issued in Chinese Application No. 200580013730.4 on Mar. 27, 2009; 9 pages.

Second Office Action issued in Chinese Application No. 200580013730.4 on Dec. 12, 2010; 10 pages.

Third Office Action issued in Chinese Application No. 200580013730.4 on Mar. 8, 2011; 10 pages.

Notice of Allowance issued in Chinese Application No. 200580013730.4 on Jul. 28, 2011; 4 pages.

Fourth Office Action. Chinese Application No. 200380105435.2. Dated: Aug. 3, 2011.

First Examination Report issued in Indian Application No. 6068/DELNP/2006 on Jun. 3, 2010; 2 pages.

Patent Certificate. Indian Patent Application No. 1956/DELNP/2005. Dated: Oct. 31, 2003.

Notice of Reasons for Rejection issued in Japanese Application No. 2007-509840 on Jun. 15, 2009; 5 pages.

Notice of Allowance issued in Japanese Application No. 2007-509840 on Jan. 25, 2010; 3 pages.

Notice Requesting Submission of Opinion issued in Korean Application No. 10-2006-7025081 on Nov. 16, 2007; 10 pages.

Notice of Decision of Final Rejection issued Korean Application No. 10-2006-7025081 on Jun. 18, 2008.

Trial Decision issued in Korean Application No. 10-2006-7025081 on Jul. 27, 2009; 10 pages.

Notice of Decision for Patent issued in Korean Application No. 10-2006-7025081 on Aug. 7, 2009; 3 pages.

Certificate of Grant of Patent. Singapore Patent No. 112419. Dated: Apr. 30, 2007.

Certificate of Grant of Patent. Hong Kong Patent No. 1080315. Dated: Apr. 24, 2009.

Boyce, "Microsoft Outlook 2010 Inside Out," XP055196121, Microsoft Press, Aug. 15, 2010, 152 pages.

Extended European Search Report in European Application No. 12847536.5, dated Jun. 29, 2015, 8 pages.

United States Office Action in U.S. Appl. No. 13/25,097, dated Feb. 24, 2015, 22 pages.

United States Office Action in U.S. Appl. No. 13/801,437, dated Mar. 2, 2015, 53 pages.

European Communication Pursuant to Article 94(3) EPC in European Application No. 12189773.0, dated Feb. 5, 2015, 6 pages.

Chinese Office Action in Chinese Application No. 201110308441.4, dated Jan. 20, 2015, 5 pages.

(56)

References Cited

OTHER PUBLICATIONS

United States Office Action in U.S. Appl. No. 13/293,743, dated Apr. 8, 2015, 15 pages.

United States Office Action in U.S. Appl. No. 13/529,509, dated Apr. 8, 2015, 13 pages.

Saha Saurabh, "Auto-Open Certain Websites in Google Chrome Incognito Private Mode", Dec. 31; 2012, <<http://web.archive.org/>

[web/20121231021254/http://www.techgyd.com/auto-open-sites-in-google-incognito/360](http://www.techgyd.com/auto-open-sites-in-google-incognito/360)>, 5 pages.

Extended European Search Report issued in European Application No. 13165229.9 on Nov. 10, 2015.

Japanese Notice of Reasons for Rejection mailed on Jun. 15, 2009 for Japanese Patent Application No. 2007-509840.

Singh, Anish, Australian Patent Office, Australian Application No. 20090202857, filed Apr. 29, 2005, in Examiner's First Report, mailed Nov. 5, 2010, 3 pages.

* cited by examiner

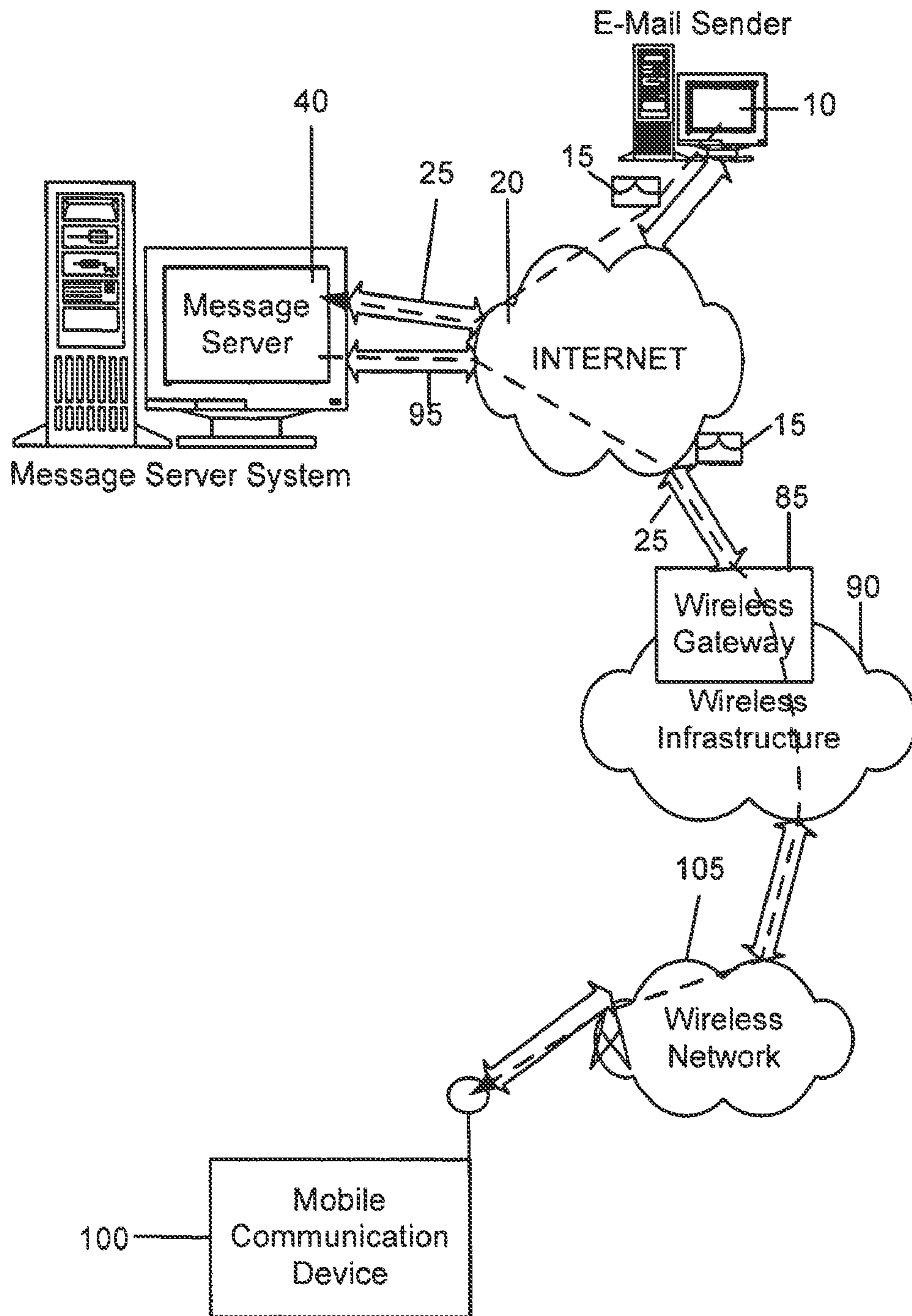

FIG. 1

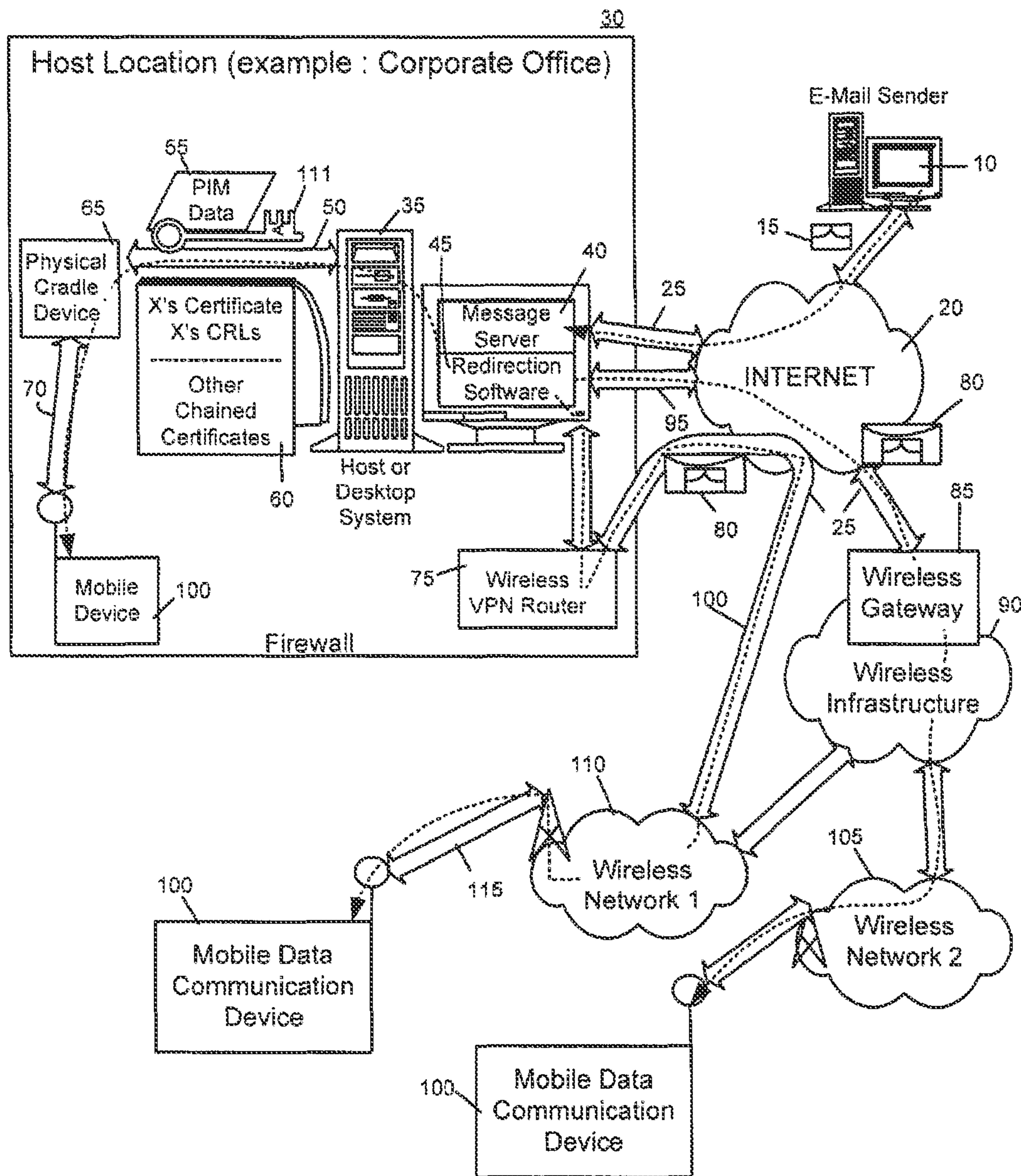

FIG. 2

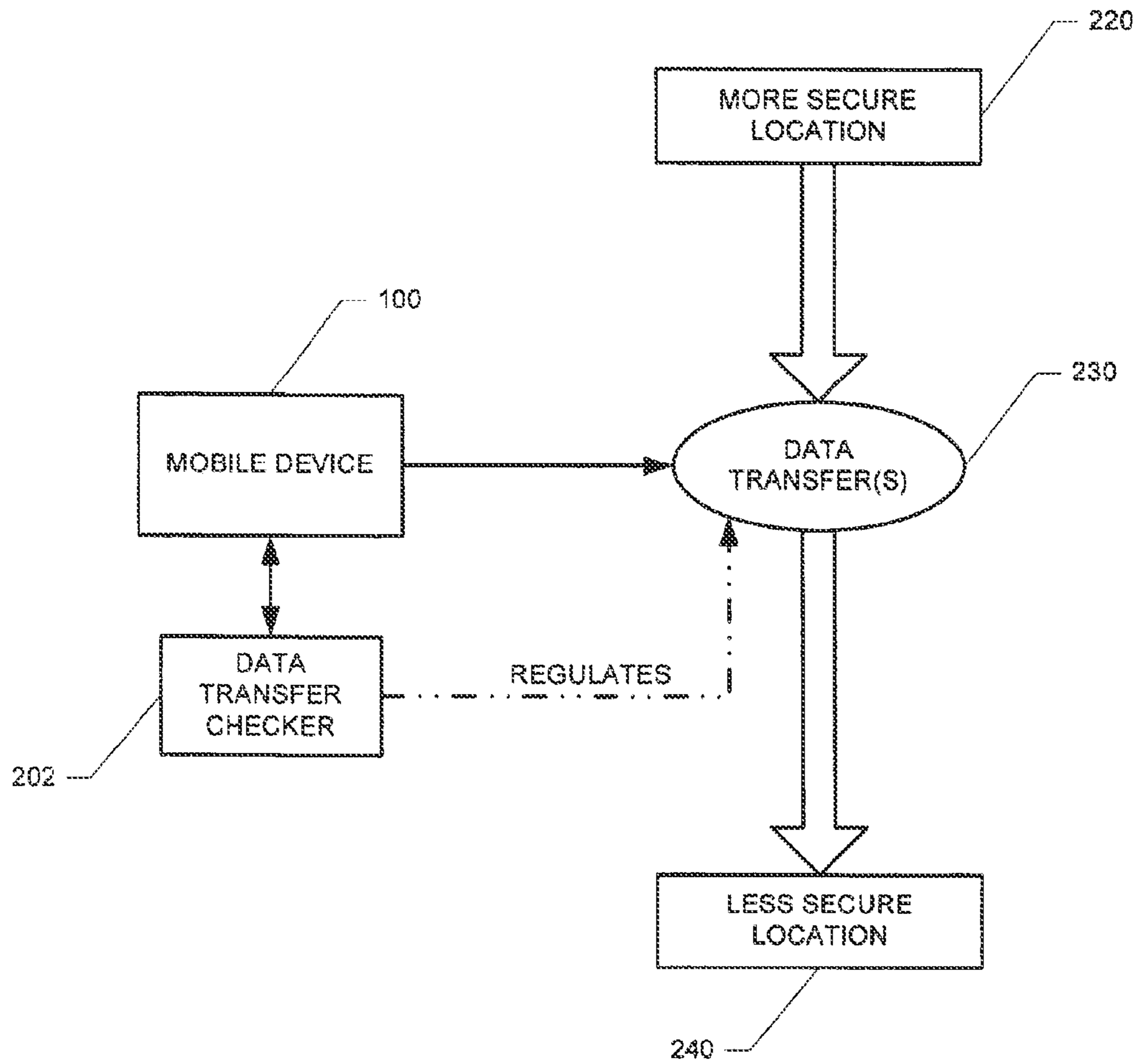

FIG. 3

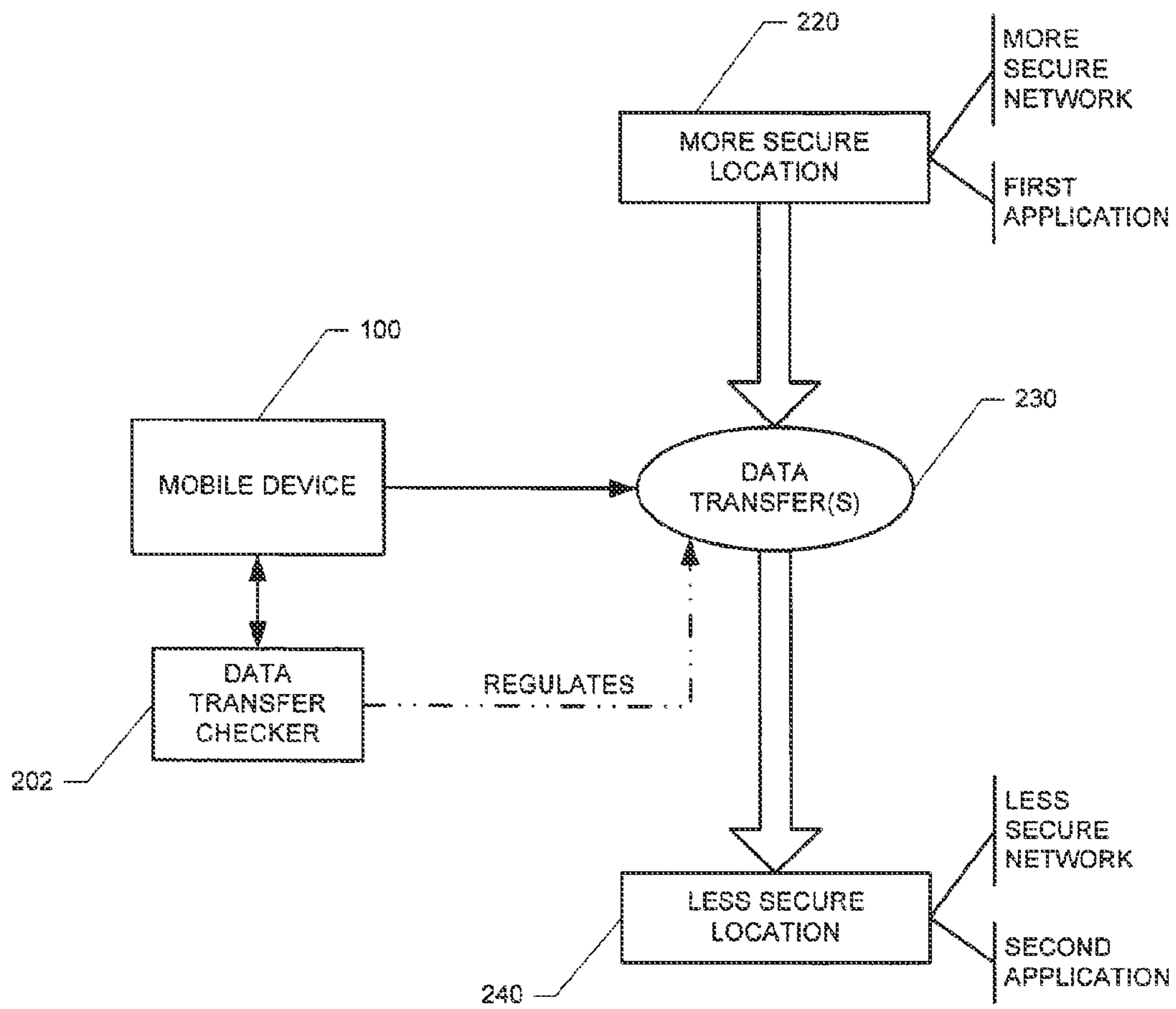

FIG. 4

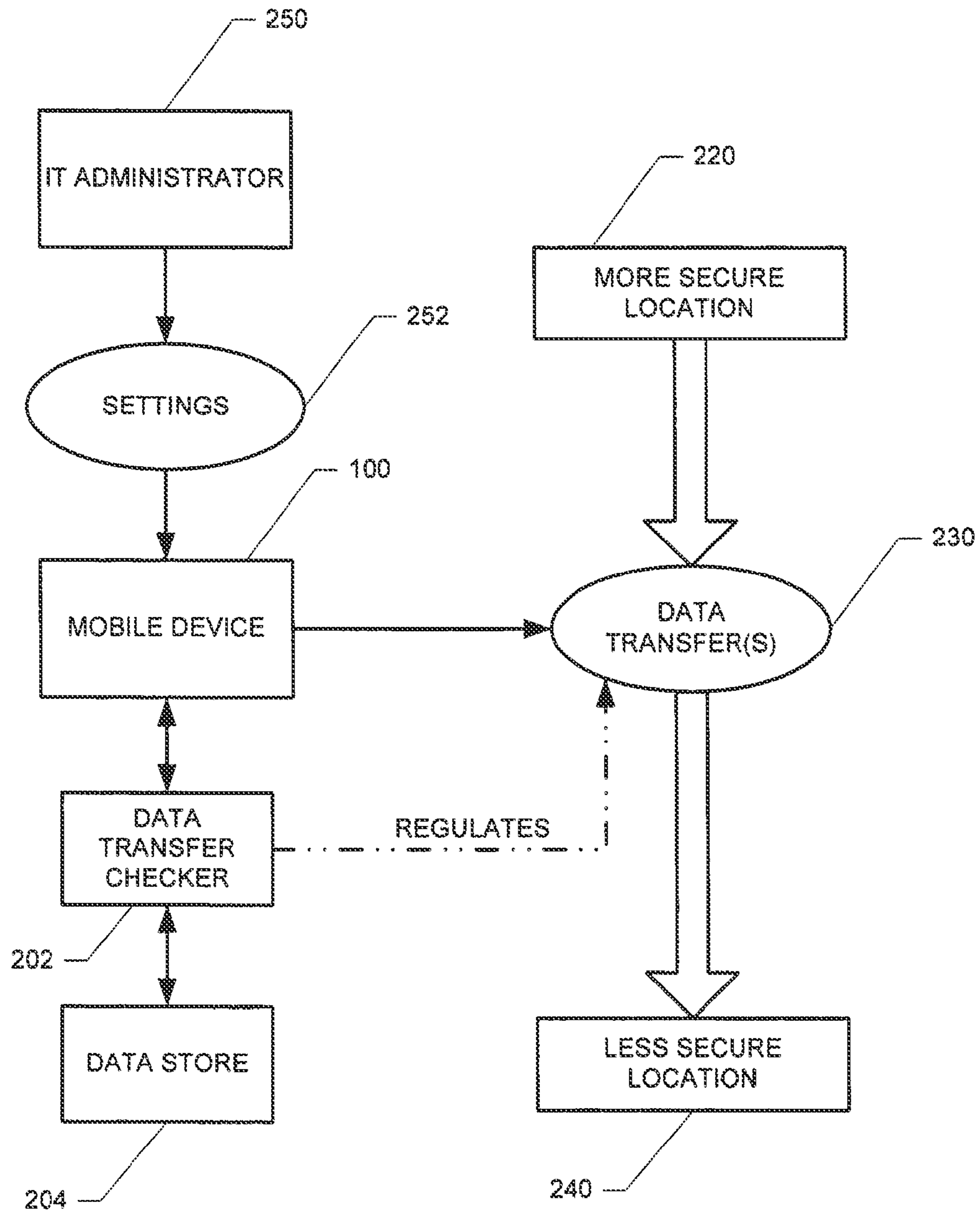

FIG. 5

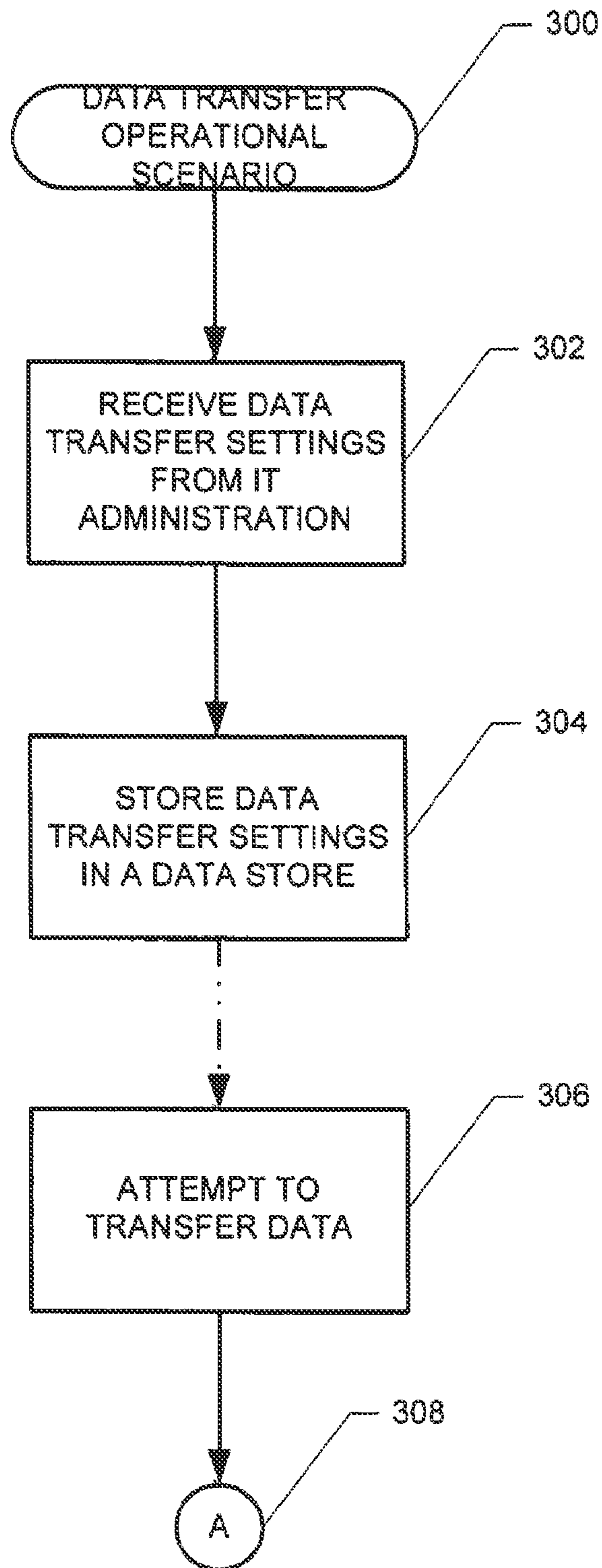

FIG. 6

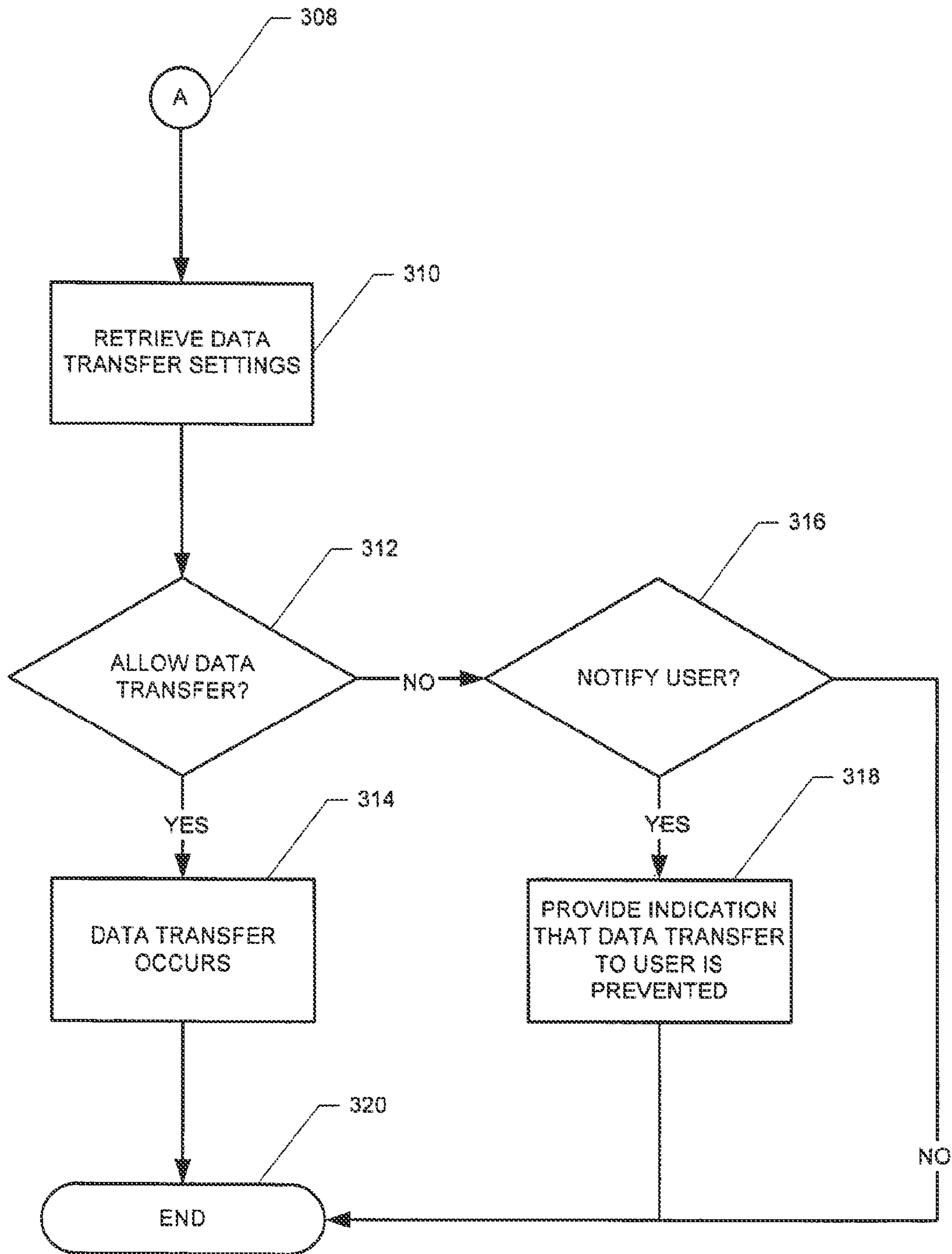

FIG. 7

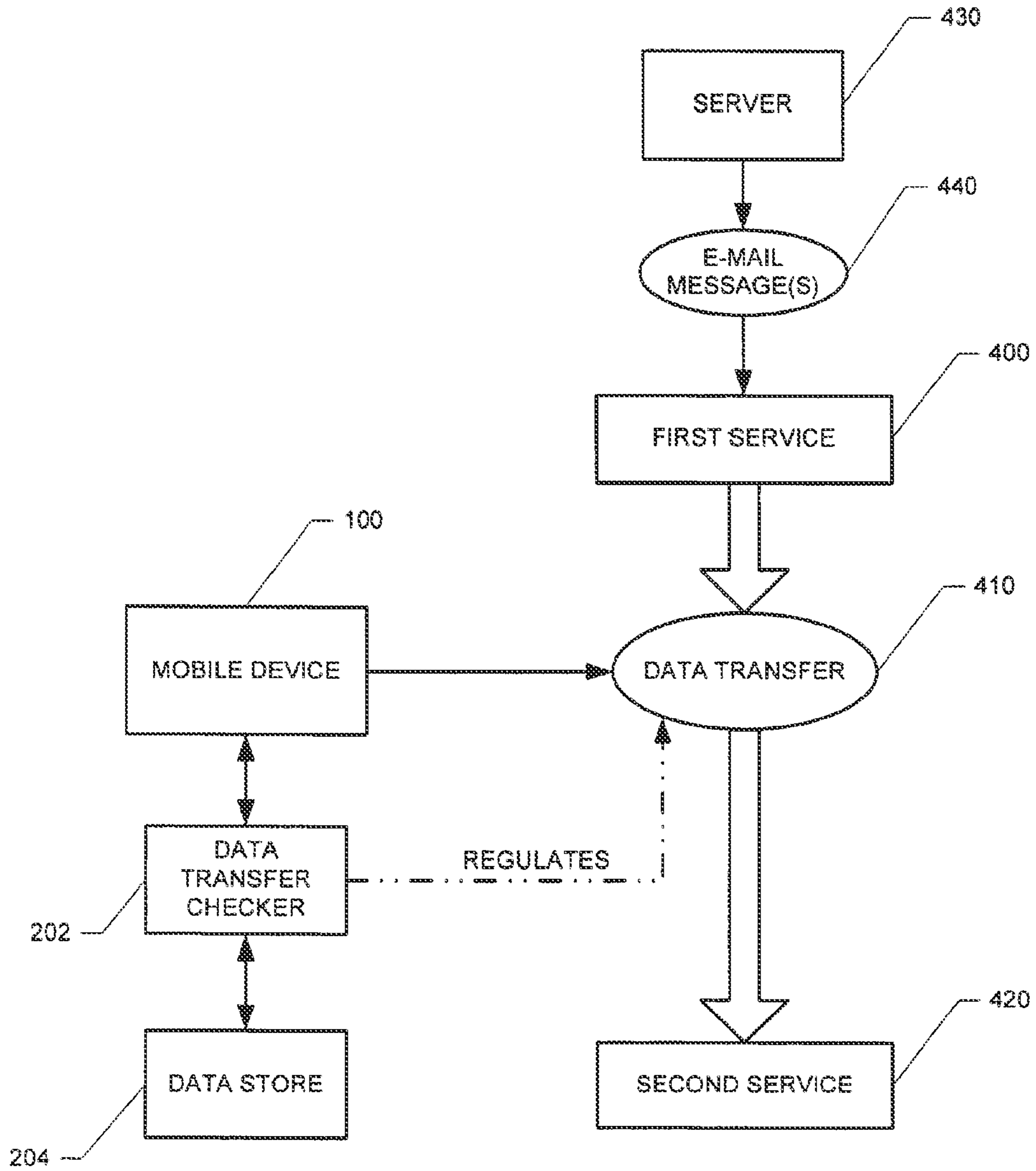

FIG. 8

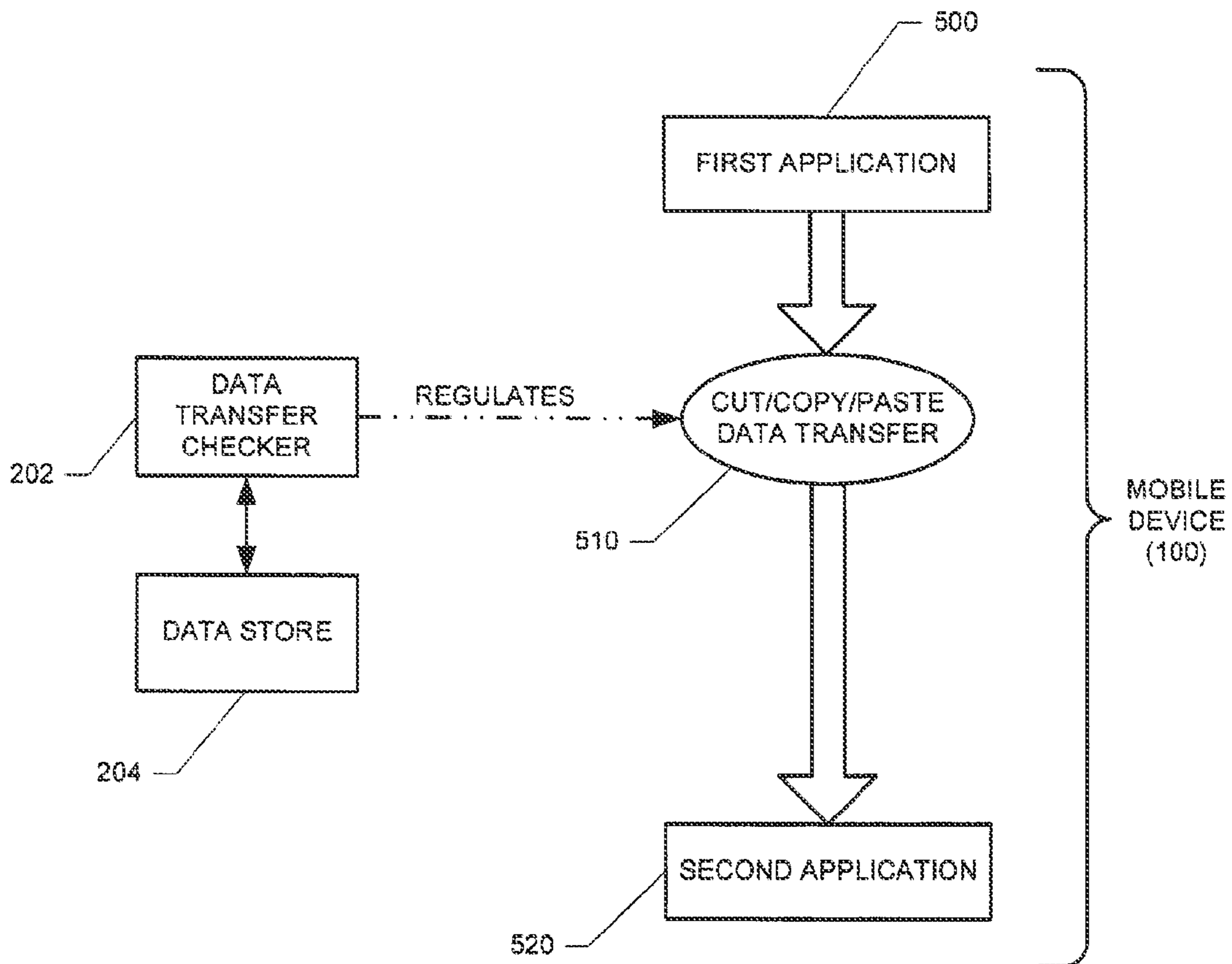

FIG. 9

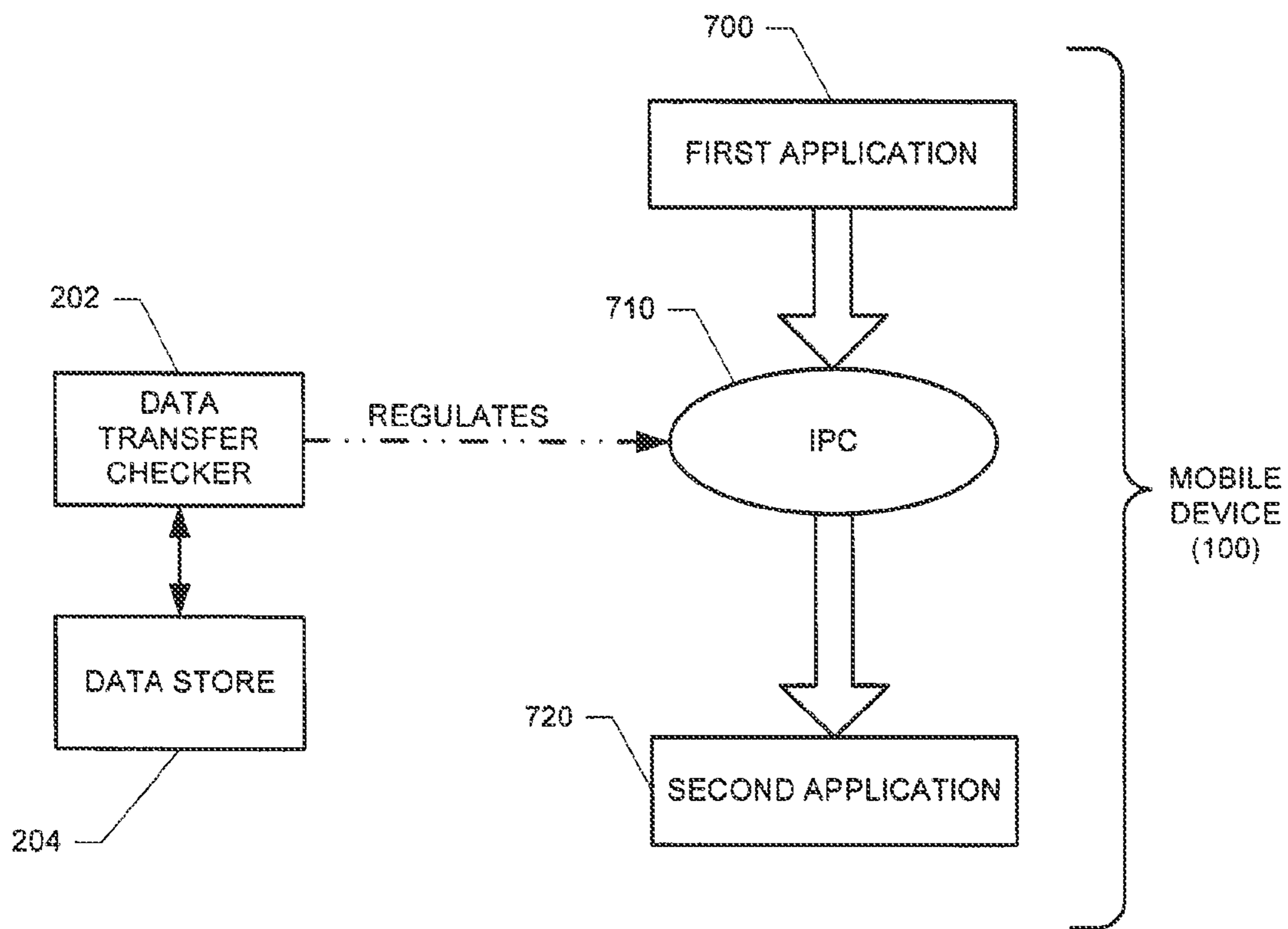

FIG. 10

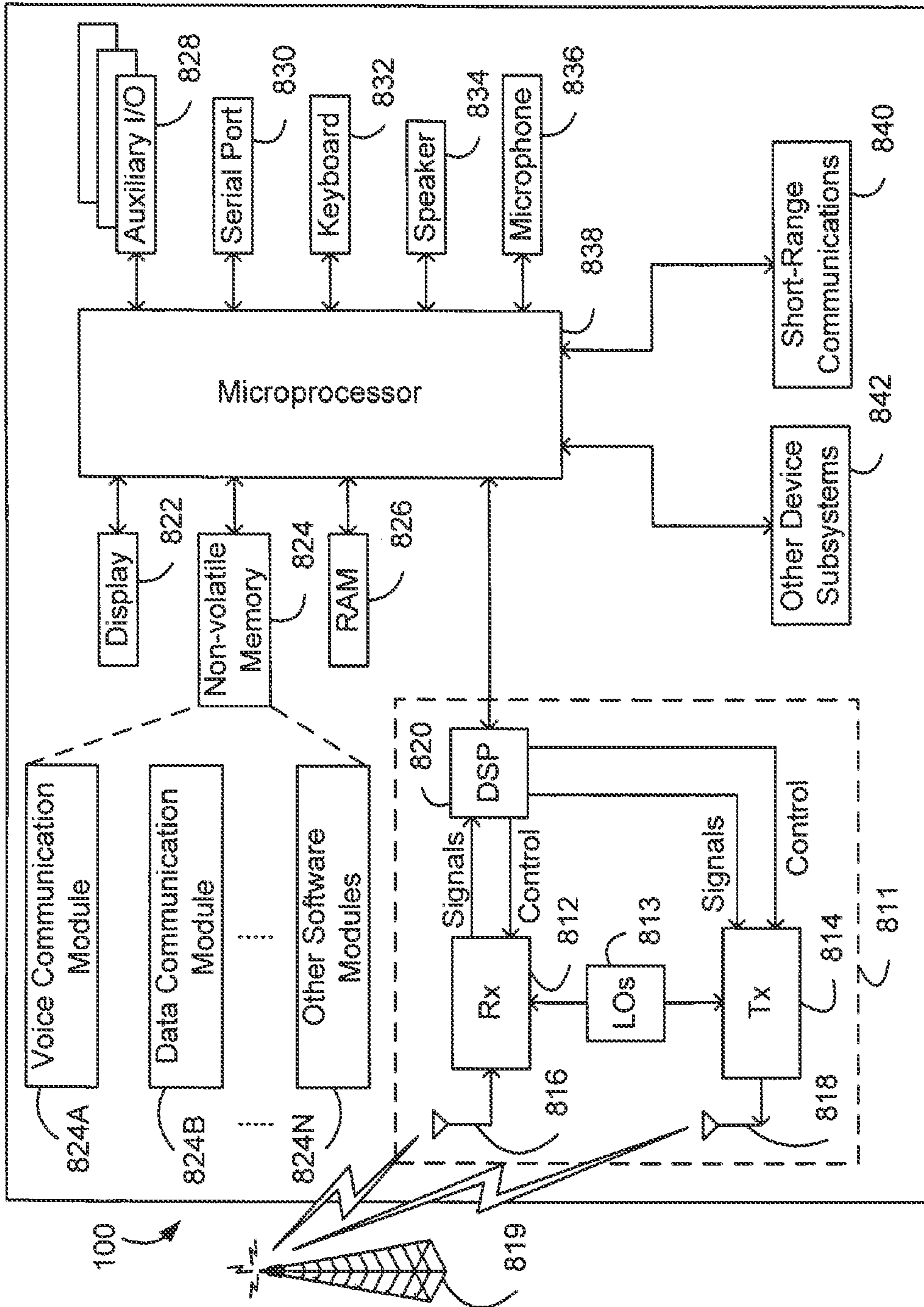

FIG. 11

SYSTEM AND METHOD FOR HANDLING DATA TRANSFERS

Matter enclosed in heavy brackets [] appears in the original patent but forms no part of this reissue specification; matter printed in italics indicates the additions made by reissue; a claim printed with strikethrough indicates that the claim was canceled, disclaimed, or held invalid by a prior post-patent action or proceeding.

This application is a continuation reissue application of reissue application Ser. No. 13/490,956, filed on Jun. 7, 2012, and is a reissue of U.S. Pat. No. 8,005,469.

CROSS-REFERENCE TO RELATED APPLICATIONS

This application is a continuation of the U.S. patent application Ser. No. 11/118,791, filed Apr. 29, 2005, entitled "SYSTEM AND METHOD FOR HANDLING DATA TRANSFERS." This application and the '791 application claim priority to and the benefit of commonly assigned U.S. Provisional Application having Ser. No. 60/567,293, filed on Apr. 30, 2004, entitled "SYSTEM AND METHOD FOR HANDLING DATA TRANSFERS." All of these are hereby incorporated into this application by reference.

BACKGROUND

1. Technical Field

This document relates generally to the field of communications, and in particular to handling data transfers that involve mobile wireless communications devices.

2. Description of the Related Art

Some companies or governments have different types of networks based on different levels of security. Some of the networks are more secure than others and provide additional levels of security, as well as different procedures for using that network. It is a security concern for data to move between the networks, specifically from a more secure network to a weaker network. An additional problem is how to prevent a malicious application from siphoning data from inside a corporation's firewall to outside the firewall.

For example the government may have a secret network and a non-secret network. The workstations on the secret network may not even be connected to the non-secret network to explicitly prevent data siphoning. To prevent data siphoning between these networks for mobile communications, the government would have to deploy two separate PDAs to each employee that uses both of the networks. This is a costly approach.

As another example, an organization may wish to deploy handhelds to employees, which connect to their corporate network as well as their personal (home) email accounts. It would be detrimental for an employee to siphon data between their corporate secure network to their personal accounts.

BRIEF DESCRIPTION OF THE DRAWINGS

FIG. 1 is an overview of an example communication system in which a wireless communication device may be used.

FIG. 2 is a block diagram of a further example communication system including multiple networks and multiple mobile communication devices.

FIGS. 3 and 4 are block diagrams depicting management of data transfers between a secure location and a less secure location.

FIG. 5 is a block diagram depicting an IT administrator providing data transfer settings to a mobile device.

FIGS. 6 and 7 are flowcharts depicting a data transfer operational scenario.

FIG. 8 is a block diagram depicting a data transfer prevention feature wherein data forwarding between service books is prevented. FIG. 9 is a block diagram depicting a data transfer prevention feature wherein cut/copy/paste operations are disabled for applications on a mobile device.

FIG. 10 is a block diagram depicting a data transfer prevention feature wherein Inter-Process Communication (IPC) are disabled between applications operating on a mobile device.

FIG. 11 is a block diagram of an example mobile device.

DETAILED DESCRIPTION OF THE DRAWINGS

FIG. 1 is an overview of an example communication system in which a wireless communication device may be used. One skilled in the art will appreciate that there may be many different topologies, but the system shown in FIG. 1 helps demonstrate the operation of the encoded message processing systems and methods described in the present application. There may also be many message senders and recipients. The simple system shown in FIG. 1 is for illustrative purposes only, and shows perhaps the most prevalent Internet e-mail environment where security is not generally used.

FIG. 1 shows an e-mail sender 10, the Internet 20, a message server system 40, a wireless gateway 85, wireless infrastructure 90, a wireless network 105 and a mobile communication device 100.

An e-mail sender system 10 may, for example, be connected to an ISP (Internet Service Provider) on which a user of the system 10 has an account, located within a company, possibly connected to a local area network (LAN), and connected to the Internet 20, or connected to the Internet 20 through a large ASP (application service provider) such as America Online (AOL). Those skilled in the art will appreciate that the systems shown in FIG. 1 may instead be connected to a wide area network (WAN) other than the Internet, although e-mail transfers are commonly accomplished through Internet-connected arrangements as shown in FIG. 1.

The message server 40 may be implemented, for example, on a network computer within the firewall of a corporation, a computer within an ISP or ASP system or the like, and acts as the main interface for e-mail exchange over the Internet 20. Although other messaging systems might not require a message server system 40, a mobile device 100 configured for receiving and possibly sending e-mail will normally be associated with an account on a message server. Perhaps the two most common message servers are Microsoft Exchange™ and Lotus Domino™. These products are often used in conjunction with Internet mail routers that route and deliver mail. These intermediate components are not shown in FIG. 1, as they do not directly play a role in the secure message processing described below. Message servers such as server 40 typically extend beyond just e-mail sending and receiving; they also include dynamic database storage engines that have predefined database formats for data like calendars, to-do lists, task lists, e-mail and documentation.

The wireless gateway 85 and infrastructure 90 provide a link between the Internet 20 and wireless network 105. The wireless infrastructure 90 determines the most likely network for locating a given user and tracks the user as they roam

between countries or networks. A message is then delivered to the mobile device **100** via wireless transmission, typically at a radio frequency (RF), from a base station in the wireless network **105** to the mobile device **100**. the particular network **105** may be virtually any wireless network over which mes-
 5 sages may be exchanged with a mobile communication device.

As shown in FIG. 1, a composed e-mail message **15** is sent by the e-mail sender **10**, located somewhere on the Internet **20**. This message **15** is normally fully in the clear and uses
 10 traditional Simple Mail Transfer Protocol (SMTP), RFC822 headers and Multipurpose Internet Mail Extension (MIME) body parts to define the format of the mail message. These techniques are all well known to those skilled in the art. The message **15** arrives at the message server **40** and is normally
 15 stored in a message store. Most known messaging systems support a so-called "pull" message access scheme, wherein the mobile device **100** must request that stored messages be forwarded by the message server to the mobile device **100**.
 20 Some systems provide for automatic routing of such messages which are addressed using a specific e-mail address associated with the mobile device **100**. In a preferred embodiment described in further detail below, messages addressed to
 25 a message server account associated with a host system such as a home computer or office computer which belongs to the user of a mobile device **100** are redirected from the message server **40** to the mobile device **100** as they are received.

Regardless of the specific mechanism controlling the forwarding of messages to the mobile device **100**, the message **15**, or possibly a translated or reformatted version thereof, is
 30 sent to the wireless gateway **85**. The wireless infrastructure **90** includes a series of connections to wireless network **105**. These connections could be Integrated Services Digital Network (ISDN), Frame Relay or T1 connections using the TCP/
 35 IP protocol used throughout the Internet. As used herein, the term "wireless network" is intended to include three different types of networks, those being (1) data-centric wireless networks, (2) voice-centric wireless networks and (3) dual-mode
 40 networks that can support both voice and data communications over the same physical base stations. Combined dual-mode networks include, but are not limited to, (1) Code Division Multiple Access (CDMA) networks, (2) the Groupe
 45 Special Mobile or the Global System for Mobile Communications (GSM) and the General Packet Radio Service (GPRS) networks, and (3) future third-generation (3G) networks like Enhanced Data-rates for Global Evolution (EDGE) and Uni-
 50 versal Mobile Telecommunications Systems (UMTS). Some older examples of data-centric network include the Mobitex™ Radio Network and the DataTAC™ Radio Network. Examples of older voice-centric data networks include Per-
 55 sonal Communication Systems (PCS) networks like GSM, and TDMA systems.

FIG. 2 is a block diagram of a further example communi-
 60 cation system including multiple networks and multiple mobile communication devices. The system of FIG. 2 is substantially similar to the FIG. 1 system, but includes a host system **30**, a redirection program **45**, a mobile device cradle **65**, a wireless virtual private network (VPN) router **75**, an additional wireless network **110** and multiple mobile com-
 65 munication devices **100**. As described above in conjunction with FIG. 1, FIG. 2 represents an overview of a sample network topology. Although the encoded message processing systems and methods described herein may be applied to networks having many different topologies, the network of
 FIG. 2 is useful in understanding an automatic e-mail redirection system mentioned briefly above.

The central host system **30** will typically be a corporate office or other LAN, but may instead be a home office com-
 5 puter or some other private system where mail messages are being exchanged. Within the host system **30** is the message server **40**, running on some computer within the firewall of the host system, that acts as the main interface for the host
 10 system to exchange e-mail with the Internet **20**. In the system of FIG. 2, the redirection program **45** enables redirection of data items from the server **40** to a mobile communication device **100**. Although the redirection program **45** is shown to
 15 reside on the same machine as the message server **40** for ease of presentation, there is no requirement that it must reside on the message server. The redirection program **45** and the mes-
 20 sage server **40** are designed to co-operate and interact to allow the pushing of information to mobile devices **100**. In this installation, the redirection program **45** takes confidential and non-confidential corporate information for a specific user and
 25 redirects it out through the corporate firewall to mobile devices **100**. A more detailed description of the redirection software **45** may be found in the commonly assigned U.S. Pat. No. 6,219,694 ("the '694 patent"), entitled "System and
 30 Method for Pushing Information From A Host System To A Mobile Data Communication Device Having A Shared Electronic Address", and issued to the assignee of the instant applications on Apr. 17, 2001 which is hereby incorporated
 into the present application by reference. This push technique may use a wireless friendly encoding, compression and encryption technique to deliver all information to a mobile
 35 device, thus effectively extending the security firewall to include each mobile device **100** associated with the host system **30**.

As shown in FIG. 2, there may be many alternative paths for getting information to the mobile device **100**. One method
 40 for loading information onto the mobile device **100** is through a port designated **50**, using a device cradle **65**. This method tends to be useful for bulk information updates often performed at initialization of a mobile device **100** with the host
 45 system **30** or a computer **35** within the system **30**. The other main method for data exchange is over-the-air using wireless networks to deliver the information. As shown in FIG. 2, this may be accomplished through a wireless VPN router **75** or
 50 through a traditional Internet connection **95** to a wireless gateway **85** and a wireless infrastructure **90**, as described above. The concept of a wireless VPN router **75** is new in the wireless industry and implies that a VPN connection could be
 55 established directly through a specific wireless network **110** to a mobile device **100**. The possibility of using a wireless VPN router **75** has only recently been available and could be used when the new Internet Protocol (IP) Version 6 (IPV6)
 60 arrives into IP-based wireless networks. This new protocol will provide enough IP addresses to dedicate an IP address to every mobile device **100** and thus make it possible to push information to a mobile device **100** at any time. A principal
 65 advantage of using this wireless VPN router **75** is that it could be an off-the-shelf VPN component, thus it would not require a separate wireless gateway **85** and wireless infrastructure **90** to be used. A VPN connection would preferably be a Trans-
 mission Control Protocol (TCP)/IP or User Datagram Protocol (UDP)/IP connection to deliver the messages directly to the mobile device **100**. If a wireless VPN **75** is not available then a link **95** to the Internet **20** is the most common connec-
 tion mechanism available and has been described above.

In the automatic redirection system of FIG. 2, a composed e-mail message **15** leaving the e-mail sender **10** arrives at the
 70 message server **40** and is redirected by the redirection program **45** to the mobile device **100**. As this redirection takes place the message **15** is re-enveloped, as indicated at **80**, and

a possibly proprietary compression and encryption algorithm can then be applied to the original message **15**. In this way, messages being read on the mobile device **100** are no less secure than if they were read on a desktop workstation such as **35** within the firewall. All messages exchanged between the redirection program **45** and the mobile device **100** preferably use this message repackaging technique. Another goal of this outer envelope is to maintain the addressing information of the original message except the sender's and the receiver's address. This allows reply messages to reach the appropriate destination, and also allows the "from" field to reflect the mobile user's desktop address. Using the user's e-mail address from the mobile device **100** allows the received message to appear as though the message originated from the user's desktop system **35** rather than the mobile device **100**.

With reference back to the port **50** and cradle **65** connectivity to the mobile device **100**, this connection path offers many advantages for enabling one-time data exchange of large items. For those skilled in the art of personal digital assistants (PDAs) and synchronization, the most common data exchanged over this link is Personal Information Management (PIM) data **55**. When exchanged for the first time this data tends to be large in quantity, bulky in nature and requires a large bandwidth to get loaded onto the mobile device **100** where it can be used on the road. This serial link may also be used for other purposes, including setting up a private security key **111** such as an S/MIME or PGP specific private key, the Certificate (Cert) of the user and their Certificate Revocation Lists (CRLs) **60**. The private key is preferably exchanged so that the desktop **35** and mobile device **100** share one personality and one method for accessing all mail. The Cert and CRLs are normally exchanged over such a link because they represent a large amount of the data that is required by the device for S/MIME, PGP and other public key security methods.

FIG. **3** depicts a system wherein data transfers **230** between a secure location **220** and a less secure location **240** is managed on a mobile device **100** by a data transfer checker **202**. A data transfer checker **202** can be implemented on a mobile device **100** as a software routine or in hardware or firmware. FIG. **4** provides several examples of locations **220** and **240**. For example, location **220** may be a top-secret or secure network and location **240** may be an unrestricted network.

As another example, location **220** may be a first application that has received sensitive or confidential information. An attempt to transfer data from the first application to a second application may be prevented by the data transfer checker **202** because if the data transfer is successful to the second application, then the second application might be used to disseminate the sensitive data to an unsecured location.

FIG. **5** depicts an IT (information technology) administrator **250** (or its agent) providing data transfer criterion or settings **252** to a mobile device **100**. The settings **252** can indicate what data transfers **230** are permitted and which ones are not permitted. The settings **252** can be stored in a data store **204** located on the mobile device **100** for access by a data transfer checker **202**.

The IT administrator **250** can specify data transfer settings **252** to one or more devices. The settings **252** may be provided to the mobile device **100** over a network (or other data connection mechanism) in order to update the data store **204** on the mobile device **100**. The mobile device **100** can be preprogrammed with the settings and can be updated by the IT administrator **250** or can have the initial settings provided by the IT administrator **250**.

This provides, among other things, companies with the capability to customize data transfer settings to suit their

needs. Also, an IT administrator **250** can provide the same settings to all mobile devices of the company, thereby ensuring that company mobile devices adhere to a consistent IT policy.

An IT policy can be enforced upon mobile devices in many ways, such as through the approaches described in the following commonly assigned United States patent application which is hereby incorporated by reference: "System And Method Of Owner Control Of Electronic Devices" (Ser. No. 10/732,132 filed on Dec. 10, 2003). This document illustrates how a user of the mobile device can be prevented from altering or erasing owner control information (e.g., data transfer settings **252**) specified by an IT administrator **250**.

FIGS. **6** and **7** illustrate a data transfer operational scenario **300**. At step **302** in the operational scenario, data transfer settings can be provided to one or more mobile devices by IT administration personnel. A company's IT policy can specify that many different data transfer-related features can be enabled/disabled. As an illustration, the data transfer settings can enable/disable such security-related aspects associated with data transfers as the following:

- whether data forwarding between service books should be allowed.
- whether cut/copy/paste operations between applications should be allowed.
- whether applications should be prevented from opening an internal and an external connection.
- whether IPC (interprocess communication) should be allowed between applications.

Using one or more of these features, the company can help ensure that their private data is kept secure. The data transfer settings are stored at step **304** in one or more data stores that are located on the mobile device.

At step **306**, there is an attempt in this operational scenario to transfer data from a first location to a second location. Step **310** retrieves the data transfer settings, and decision step **312** examines whether the data transfer should occur in view of the data transfer settings. If the data transfer should occur as determined by decision step **312**, then the data transfer occurs between the first location and the second location, and processing for this operational scenario terminates at end block **320**.

However, if decision step **312** determines that the data transfer should not be allowed in view of the settings, then decision step **316** determines whether the user should be notified that the data transfer is not permitted. If the user is not to be notified (e.g., because the settings do not allow a feedback message), then processing for this operational scenario terminates at end block **320**. However, if the user is to be notified as determined by decision block **316**, then an indication is provided at step **318** to the user that the data transfer is being prevented. Processing for this operational scenario terminates at end block **320**.

It should be understood that similar to the other processing flows described herein, the steps and the order of the steps in the flowchart described herein may be altered, modified and/or augmented and still achieve the desired outcome.

FIG. **8** illustrates a data transfer prevention feature mentioned above wherein data transfer **410** between services (**400**, **420**) is prevented. Exemplary services comprise a company email service, a user's personal e-mail service, and an instant messaging service. This data transfer prevention feature allows the company to disable improper forwarding/replying between services. For example, if a user receives an email message via a first service **400**, the user is unable to forward it to another email account via a second service **420** (such as a personal e-mail account of the user). Optionally,

messages **440** that arrive via a source e-mail server **430** must be replied to or forwarded back through the same source e-mail server **430** from which the message **440** arrived.

FIG. **9** illustrates a data transfer prevention feature mentioned above wherein cut/copy/paste operations **510** are disabled for all or designated applications on the handheld mobile device **100**. As an illustration, even if the forwarding between applications or services is disabled, a determined user may copy messages from one application **500**, compose a new message in a different application **520** and send it through the different application **520**. Disabling cut/copy/paste operations makes this much more difficult for the user to siphon data because they would be forced to retype the entire message or data.

FIG. **10** illustrates a data transfer prevention feature mentioned above wherein Inter-Process Communication (IPC) **710** can be disabled between applications (**700**, **720**) that operate on a mobile device **100**. As is known to one skilled in the art, an application may initiate one or more processes in order to accomplish certain tasks on the handheld mobile device **100**. This data transfer prevention feature would prevent two malicious applications (**700**, **720**) working together to siphon data. As an example, one application **700** could open up a connection inside the firewall, and another application **720** could open a connection outside the firewall. Then using IPC **710**, they could transfer data between the two applications (**700**, **720**) and effectively siphon data. Disabling IPC between the applications (**700**, **720**) prevents this type of attack from occurring.

The data transfer prevention provided by a data transfer checker **202** would inadvertently prohibit IPC between an e-mail program and an address book that are operating on the mobile device **100**. Thus, a company can additionally choose which applications are allowed to use IPC, as some applications, such as the e-mail program and the address book, may have a valid use for it.

The systems and methods disclosed herein are presented only by way of example and are not meant to limit the scope of the invention. Other variations of the systems and methods described above will be apparent to those skilled in the art and as such are considered to be within the scope of the invention. For example, a system and method can be configured to include the following. A data transfer checker operating on a mobile device determines whether an attempted data transfer between two locations is permitted. If it is not permitted, then the data transfer is prevented and the user may be notified of the data transfer prevention.

As another example of a system and method, a system and method can receive a data transfer request to transfer data from a first location to a second location, wherein the first location is more secure than the second location. Data transfer settings are retrieved from a data store responsive to receiving the data transfer request. The data transfer settings indicate whether a data transfer is to occur based upon a security-related aspect associated with the data transfer. The data transfer settings are used to determine whether to transfer the data from the first location to the second location based upon the data transfer settings. The data is transferred responsive to the determining step.

A system and method may be configured to consider one or more different data transfer security-related aspects, such as level of security associated with the destination of the data transfer. As other examples, a security related aspect can include the type of communication operation to be performed between the first locations and the second location such as the type of communication to occur. The type of data transfer operation could include data forwarding between service

books, opening an internal and an external connection, an Inter-Process Communication (IPC) between applications, and/or a cut-copy-paste type operation between applications.

As another example, the systems and methods disclosed herein may be used with many different computers and devices, such as a wireless mobile communications device shown in FIG. **11**. With reference to FIG. **11**, the mobile device **100** is a dual-mode mobile device and includes a transceiver **811**, a microprocessor **838**, a display **822**, non-volatile memory **824**, random access memory (RAM) **826**, one or more auxiliary input/output (I/O) devices **828**, a serial port **830**, a keyboard **832**, a speaker **834**, a microphone **836**, a short-range wireless communications sub-system **840**, and other device sub-systems **842**.

The transceiver **811** includes a receiver **812**, a transmitter **814**, antennas **816** and **818**, one or more local oscillators **813**, and a digital signal processor (DSP) **820**. The antennas **816** and **818** may be antenna elements of a multiple-element antenna, and are preferably embedded antennas. However, the systems and methods described herein are in no way restricted to a particular type of antenna, or even to wireless communication devices.

The mobile device **100** is preferably a two-way communication device having voice and data communication capabilities. Thus, for example, the mobile device **100** may communicate over a voice network, such as any of the analog or digital cellular networks, and may also communicate over a data network. The voice and data networks are depicted in FIG. **11** by the communication tower **819**. These voice and data networks may be separate communication networks using separate infrastructure, such as base stations, network controllers, etc., or they may be integrated into a single wireless network.

The transceiver **811** is used to communicate with the network **819**, and includes the receiver **812**, the transmitter **814**, the one or more local oscillators **813** and the DSP **820**. The DSP **820** is used to send and receive signals to and from the transceivers **816** and **818**, and also provides control information to the receiver **812** and the transmitter **814**. If the voice and data communications occur at a single frequency, or closely-spaced sets of frequencies, then a single local oscillator **813** may be used in conjunction with the receiver **812** and the transmitter **814**. Alternatively, if different frequencies are utilized for voice communications versus data communications for example, then a plurality of local oscillators **813** can be used to generate a plurality of frequencies corresponding to the voice and data networks **819**. Information, which includes both voice and data information, is communicated to and from the transceiver **811** via a link between the DSP **820** and the microprocessor **838**.

The detailed design of the transceiver **811**, such as frequency band, component selection, power level, etc., will be dependent upon the communication network **819** in which the mobile device **100** is intended to operate. For example, a mobile device **100** intended to operate in a North American market may include a transceiver **811** designed to operate with any of a variety of voice communication networks, such as the Mobitex or DataTAC mobile data communication networks, AMPS, TDMA, CDMA, PCS, etc., whereas a mobile device **100** intended for use in Europe may be configured to operate with the GPRS data communication network and the GSM voice communication network. Other types of data and voice networks, both separate and integrated, may also be utilized with a mobile device **100**.

Depending upon the type of network or networks **819**, the access requirements for the mobile device **100** may also vary. For example, in the Mobitex and DataTAC data networks,

mobile devices are registered on the network using a unique identification number associated with each mobile device. In GPRS data networks, however, network access is associated with a subscriber or user of a mobile device. A GPRS device typically requires a subscriber identity module (“SIM”), which is required in order to operate a mobile device on a GPRS network. Local or non-network communication functions (if any) may be operable, without the SIM device, but a mobile device will be unable to carry out any functions involving communications over the data network **819**, other than any legally required operations, such as ‘911’ emergency calling.

After any required network registration or activation procedures have been completed, the mobile device **100** may send and receive communication signals, including both voice and data signals, over the networks **819**. Signals received by the antenna **816** from the communication network **819** are routed to the receiver **812**, which provides for signal amplification, frequency down conversion, filtering, channel selection, etc., and may also provide analog to digital conversion. Analog to digital conversion of the received signal allows more complex communication functions, such as digital demodulation and decoding to be performed using the DSP **820**. In a similar manner, signals to be transmitted to the network **819** are processed, including modulation and encoding, for example, by the DSP **820** and are then provided to the transmitter **814** for digital to analog conversion, frequency up conversion, filtering, amplification and transmission to the communication network **819** via the antenna **818**.

In addition to processing the communication signals, the DSP **820** also provides for transceiver control. For example, the gain levels applied to communication signals in the receiver **812** and the transmitter **814** may be adaptively controlled through automatic gain control algorithms implemented in the DSP **820**. Other transceiver control algorithms could also be implemented in the DSP **820** in order to provide more sophisticated control of the transceiver **811**.

The microprocessor **838** preferably manages and controls the overall operation of the mobile device **100**. Many types of microprocessors or microcontrollers could be used here, or, alternatively, a single DSP **820** could be used to carry out the functions of the microprocessor **838**. Low-level communication functions, including at least data and voice communications, are performed through the DSP **820** in the transceiver **811**. Other, high-level communication applications, such as a voice communication application **824A**, and a data communication application **824B** may be stored in the non-volatile memory **824** for execution by the microprocessor **838**. For example, the voice communication module **824A** may provide a high-level user interface operable to transmit and receive voice calls between the mobile device **100** and a plurality of other voice or dual-mode devices via the network **819**. Similarly, the data communication module **824B** may provide a high-level user interface operable for sending and receiving data, such as e-mail messages, files, organizer information, short text messages, etc., between the mobile device **100** and a plurality of other data devices via the networks **819**.

The microprocessor **838** also interacts with other device subsystems, such as the display **822**, the RAM **826**, the auxiliary input/output (I/O) subsystems **828**, the serial port **830**, the keyboard **832**, the speaker **834**, the microphone **836**, the short-range communications subsystem **840** and any other device subsystems generally designated as **842**.

Some of the subsystems shown in FIG. **11** perform communication-related functions, whereas other subsystems may provide “resident” or on-device functions. Notably, some subsystems, such as the keyboard **832** and the display **822**

may be used for both communication-related functions, such as entering a text message for transmission over a data communication network, and device-resident functions such as a calculator or task list or other PDA type functions.

Operating system software used by the microprocessor **838** is preferably stored in a persistent store such as non-volatile memory **824**. The non-volatile memory **824** may be implemented, for example, as a Flash memory component, or as battery backed-up RAM. In addition to the operating system, which controls low-level functions of the mobile device **810**, the non-volatile memory **824** includes a plurality of software modules **824A-824N** that can be executed by the microprocessor **838** (and/or the DSP **820**), including a voice communication module **824A**, a data communication module **824B**, and a plurality of other operational modules **824N** for carrying out a plurality of other functions. These modules are executed by the microprocessor **838** and provide a high-level interface between a user and the mobile device **100**. This interface typically includes a graphical component provided through the display **822**, and an input/output component provided through the auxiliary I/O **828**, keyboard **832**, speaker **834**, and microphone **836**. The operating system, specific device applications or modules, or parts thereof, may be temporarily loaded into a volatile store, such as RAM **826** for faster operation. Moreover, received communication signals may also be temporarily stored to RAM **826**, before permanently writing them to a file system located in a persistent store such as the Flash memory **824**.

An exemplary application module **824N** that may be loaded onto the mobile device **100** is a personal information manager (PIM) application providing PDA functionality, such as calendar events, appointments, and task items. This module **824N** may also interact with the voice communication module **824A** for managing phone calls, voice mails, etc., and may also interact with the data communication module for managing e-mail communications and other data transmissions. Alternatively, all of the functionality of the voice communication module **824A** and the data communication module **824B** may be integrated into the PIM module.

The non-volatile memory **824** preferably also provides a file system to facilitate storage of PIM data items on the device. The PIM application preferably includes the ability to send and receive data items, either by itself, or in conjunction with the voice and data communication modules **824A**, **824B**, via the wireless networks **819**. The PIM data items are preferably seamlessly integrated, synchronized and updated, via the wireless networks **819**, with a corresponding set of data items stored or associated with a host computer system, thereby creating a mirrored system for data items associated with a particular user.

Context objects representing at least partially decoded data items, as well as fully decoded data items, are preferably stored on the mobile device **100** in a volatile and non-persistent store such as the RAM **826**. Such information may instead be stored in the non-volatile memory **824**, for example, when storage intervals are relatively short, such that the information is removed from memory soon after it is stored. However, storage of this information in the RAM **826** or another volatile and non-persistent store is preferred, in order to ensure that the information is erased from memory when the mobile device **100** loses power. This prevents an unauthorized party from obtaining any stored decoded or partially decoded information by removing a memory chip from the mobile device **100**, for example.

The mobile device **100** may be manually synchronized with a host system by placing the device **100** in an interface cradle, which couples the serial port **830** of the mobile device

100 to the serial port of a computer system or device. The serial port 830 may also be used to enable a user to set preferences through an external device or software application, or to download other application modules 824N for installation. This wired download path may be used to load an encryption key onto the device, which is a more secure method than exchanging encryption information via the wireless network 819. Interfaces for other wired download paths may be provided in the mobile device 100, in addition to or instead of the serial port 830. For example, a USB port would provide an interface to a similarly equipped personal computer.

Additional application modules 824N may be loaded onto the mobile device 100 through the networks 819, through an auxiliary I/O subsystem 828, through the serial port 830, through the short-range communications subsystem 840, or through any other suitable subsystem 842, and installed by a user in the non-volatile memory 824 or RAM 826. Such flexibility in application installation increases the functionality of the mobile device 100 and may provide enhanced on-device functions, communication-related functions, or both. For example, secure communication applications may enable electronic commerce functions and other such financial transactions to be performed using the mobile device 100.

When the mobile device 100 is operating in a data communication mode, a received signal, such as a text message or a web page download, is processed by the transceiver module 811 and provided to the microprocessor 838, which preferably further processes the received signal in multiple stages as described above, for eventual output to the display 822, or, alternatively, to an auxiliary I/O device 828. A user of mobile device 100 may also compose data items, such as e-mail messages, using the keyboard 832, which is preferably a complete alphanumeric keyboard laid out in the QWERTY style, although other styles of complete alphanumeric keyboards such as the known DVORAK style may also be used. User input to the mobile device 100 is further enhanced with a plurality of auxiliary I/O devices 828, which may include a thumbwheel input device, a touchpad, a variety of switches, a rocker input switch, etc. The composed data items input by the user may then be transmitted over the communication networks 819 via the transceiver module 811.

When the mobile device 100 is operating in a voice communication mode, the overall operation of the mobile device is substantially similar to the data mode, except that received signals are preferably be output to the speaker 834 and voice signals for transmission are generated by a microphone 836. Alternative voice or audio I/O subsystems, such as a voice message recording subsystem, may also be implemented on the mobile device 100. Although voice or audio signal output is preferably accomplished primarily through the speaker 834, the display 822 may also be used to provide an indication of the identity of a calling party, the duration of a voice call, or other voice call related information. For example, the microprocessor 838, in conjunction with the voice communication module and the operating system software, may detect the caller identification information of an incoming voice call and display it on the display 822.

A short-range communications subsystem 840 is also included in the mobile device 100. The subsystem 840 may include an infrared device and associated circuits and components, or a short-range RF communication module such as a Bluetooth™ module or an 802.11 module, for example, to provide for communication with similarly-enabled systems and devices. Those skilled in the art will appreciate that “Bluetooth” and “802.11” refer to sets of specifications, available from the Institute of Electrical and Electronics

Engineers, relating to wireless personal area networks and wireless local area networks, respectively.

The systems’ and methods’ data may be stored in one or more data stores. The data stores can be of many different types of storage devices and programming constructs, such as RAM, ROM, Flash memory, programming data structures, programming variables, etc. It is noted that data structures describe formats for use in organizing and storing data in databases, programs, memory, or other computer-readable media for use by a computer program.

The systems and methods may be provided on many different types of computer-readable media including computer storage mechanisms (e.g., CD-ROM, diskette, RAM, flash memory, computer’s hard drive, etc.) that contain instructions for use in execution by a processor to perform the methods’ operations and implement the systems described herein.

The computer components, software modules, functions and data structures described herein may be connected directly or indirectly to each other in order to allow the flow of data needed for their operations. It is also noted that a module or processor includes but is not limited to a unit of code that performs a software operation, and can be implemented for example as a subroutine unit of code, or as a software function unit of code, or as an object (as in an object-oriented paradigm), or as an applet, or in a computer script language, or as another type of computer code. The software components and/or functionality may be located on a single computing device or distributed across multiple computing devices depending upon the situation at hand.

What is claimed is:

[1. A method of handling data transfers on a device, comprising:

receiving, from an application that accesses data associated with a first location, a request to open a connection with a second location;

retrieving, from a data store on the device, one or more data transfer settings responsive to receiving the request;

wherein the one or more data transfer settings are indicative of a security-related policy for data transfers associated with the first location; and

determining whether to permit the request or not permit the request based upon the one or more data transfer settings.]

[2. The method of claim 1, wherein the first location comprises a server, wherein the second location comprises a server, and wherein the request is to open the connection via a network.]

[3. The method of claim 1, wherein the application is a first application, wherein the second location comprises a second application, wherein the request is to open the connection for Inter-Process Communication (IPC) from the first application to the second application.]

[4. The method of claim 1, wherein the determining comprises using a level of security associated with the first location, and using a level of security associated with the second location.]

[5. The method of claim 1, wherein receiving the request comprises receiving a request to transfer data from the application running on the device to another application on the device to another device.]

[6. The method of claim 1, wherein receiving the request comprises receiving a request to transfer data from the device to another device.]

[7. The method of claim 1, further comprising: receiving the one or more data transfer settings from a server via a wireless network.]

13

[8. A device, comprising:
a data store that stores a data transfer setting, wherein the data transfer setting is indicative of a security-related policy for data transfers associated with a first location;
and;

a processor configured to performs operations comprising:
receiving, from an application that accesses data associated with the first location, a request to open a connection with a second location;
retrieving, from the data store, the data transfer setting responsive to receiving the request; and
determining whether to permit the request or not permit the request based upon the data transfer setting.]

[9. The device of claim 8, wherein the first location comprises a server, wherein the second location comprises a server, and wherein the request is to open the connection via a network.]

[10. The device of claim 8, wherein the application is a first application, wherein the second location comprises a second application, wherein the request is to open the connection for Inter-Process Communication (IPC) from the first application to the second application.]

[11. The device of claim 8, wherein the determining comprises using a level of security associated with the first location, and using a level of security associated with the second location.]

[12. The device of claim 8, wherein receiving the request comprises receiving a request to transfer data from the application running on the device to another application on the device.]

[13. The device of claim 8, wherein receiving the request comprises receiving a request to transfer data from the device to another device.]

[14. The device of claim 8, the operations further comprising:

receiving the data transfer setting from a server via a wireless network; and
storing the data transfer setting in the data store.]

[15. A computer storage device encoded with a computer program, the program comprising instructions that when executed by a communication device cause the communication device to perform operations comprising:

receiving, from an application that accesses data associated with a first location, a request to open a connection with a second location;
retrieving, in response to receiving the request, once or more data transfer settings, which are indicative of a security-related policy for data transfers associated with the first location; and
determining whether to permit the request or not permit the request based upon the one or more data transfer settings.]

[16. The computer storage device of claim 15, wherein the first location comprises a server, wherein the second location comprises a server, and wherein the request is to open the connection via a network.]

[17. The computer storage device of claim 15, wherein the application is a first application, wherein the second location comprises a second application, wherein the request is to open the connection for Inter-Process Communication (IPC) from the first application to the second application.]

[18. The computer storage device of claim 15, wherein the determining comprises using a level of security associated with the first location, and using a level of security associated with the second location.]

[19. The computer storage device of claim 15, wherein receiving the request comprises receiving a request to transfer

14

data from the application running on the communication device to another application on the communication device.]

[20. The computer storage device of claim 15, wherein receiving the request comprises receiving a request to transfer data from the communication device to another communication device.]

[21. The computer storage device of claim 15, the operations further comprising:
receiving the one or more data transfer settings from a server via a wireless network.]

22. A method of handling data transfers on a device, comprising:

receiving a request to transfer data from a first application on the device to a second application on the device, the first application capable of accessing data associated with a first network and the second application capable of accessing data associated with a second network;

determining that the requested data transfer from the first application to the second application violates a security-related policy associated with the first application; and

prohibiting the requested data transfer in response to the determining.

23. The method of claim 22, wherein the first network has a first security level higher than a second security level of the second network.

24. The method of claim 22, wherein the data transfer includes pasting data cut or copied from the first application to the second application or communicating using Inter-Process Communication (IPC) between the first application and the second application.

25. The method of claim 22, wherein prohibiting the data transfer comprises preventing the first application from establishing a connection with the first network while the second application is connected with the second network or preventing transfer of the data between a first service book associated with the first application and a second service book associated with the second application.

26. The method of claim 22, wherein the determining is based on a level of security associated with the first application and a level of security associated with the second application.

27. A device, comprising:

one or more processors configured to:

receive a request to transfer data from a first application on the device to a second application on the device, the first application capable of accessing data associated with a first network and the second application capable of accessing data associated with a second network;

determine that the requested data transfer from the first application to the second application violates a security-related policy associated with the first application; and

prohibit the requested data transfer in response to the determination that the requested data transfer violates the security-related policy.

28. The device of claim 27, wherein the first network has a first security level higher than a second security level of the second network.

29. The device of claim 27, wherein the data transfer includes pasting data cut or copied from the first application to the second application or communicating using Inter-Process Communication (IPC) between the first application and the second application.

30. The device of claim 27, wherein the one or more processors configured to prohibit the data transfer comprises the

15

one or more processors configured to prevent the first application from establishing a connection with the first network while the second application is connected with the second network or prevent transfer of the data between a first service book associated with the first application and a second service book associated with the second application.

31. The device of claim 27, wherein the determination is based on a level of security associated with the first application and a level of security associated with the second application.

32. A computer program product encoded on a non-transitory medium, the product comprising computer readable instructions for causing one or more processors to perform operations comprising:

receiving a request to transfer data from a first application on the device to a second application on the device, the first application capable of accessing data associated with a first network and the second application capable of accessing data associated with a second network;

determining that the requested data transfer from the first application to the second application violates a security-related policy associated with the first application; and

16

prohibiting the requested data transfer in response to the determining.

33. The computer program product of claim 32, wherein the first network has a first security level higher than a second security level of the second network.

34. The computer program product of claim 32, wherein the data transfer includes pasting data cut or copied from the first application to the second application or communicating using Inter-Process Communication (IPC) between the first application and the second application.

35. The computer program product of claim 32, wherein the prohibiting the data transfer comprises preventing the first application from establishing a connection with the first network while the second application is connected with the second network or preventing transfer of the data between a first service book associated with the first application and a second service book associated with the second application.

36. The computer program product of claim 32, wherein the determining is based on a level of security associated with the first application and a level of security associated with the second application.

* * * * *

UNITED STATES PATENT AND TRADEMARK OFFICE
CERTIFICATE OF CORRECTION

PATENT NO. : RE46,083 E
APPLICATION NO. : 14/163416
DATED : July 26, 2016
INVENTOR(S) : Herbert Anthony Little et al.

Page 1 of 1

It is certified that error appears in the above-identified patent and that said Letters Patent is hereby corrected as shown below:

In the Claims

In Column 15, In Line 16, In Claim 32, delete “the” and insert -- a --, therefor.

Signed and Sealed this
Fourth Day of October, 2016



Michelle K. Lee
Director of the United States Patent and Trademark Office