

US00RE46044E

(19) **United States**
(12) **Reissued Patent**
Arai et al.

(10) **Patent Number:** **US RE46,044 E**
(45) **Date of Reissued Patent:** **Jun. 28, 2016**

(54) **SOFT CONTACT LENS**

(71) Applicants: **Hiroyuki Arai**, Kanagawa (JP); **Sunao Mikawa**, Tokyo (JP)

(72) Inventors: **Hiroyuki Arai**, Kanagawa (JP); **Sunao Mikawa**, Tokyo (JP)

(73) Assignee: **Universal View Co., Ltd.**, Tokyo (JP)

(21) Appl. No.: **14/133,357**

(22) Filed: **Dec. 18, 2013**

Related U.S. Patent Documents

Reissue of:

(64) Patent No.: **8,308,292**
Issued: **Nov. 13, 2012**
Appl. No.: **13/501,745**
PCT Filed: **Oct. 6, 2010**
PCT No.: **PCT/JP2010/067592**
§ 371 (c)(1),
(2) Date: **Apr. 12, 2012**
PCT Pub. No.: **WO2011/048953**
PCT Pub. Date: **Apr. 28, 2011**

(30) **Foreign Application Priority Data**

Oct. 20, 2009 (JP) 2009-241769

(51) **Int. Cl.**
G02C 7/04 (2006.01)
G02C 7/16 (2006.01)

(52) **U.S. Cl.**
CPC **G02C 7/04** (2013.01); **G02C 7/049** (2013.01);
G02C 7/165 (2013.01)

(58) **Field of Classification Search**
CPC **G02C 7/165**; **G02C 7/04**; **G02C 7/049**
USPC **351/159.24**, **159.31**, **159.33**
See application file for complete search history.

(56) **References Cited**

U.S. PATENT DOCUMENTS

3,339,997 A 9/1967 Wesley
4,576,453 A 3/1986 Borowsky
4,669,834 A 6/1987 Richter
4,955,904 A 9/1990 Atebaea et al.
4,976,732 A 12/1990 Vorosmarthy
4,994,080 A 2/1991 Shepard
5,245,367 A 9/1993 Miller
5,260,727 A * 11/1993 Oksman et al. 351/159.03

(Continued)

FOREIGN PATENT DOCUMENTS

AU 694743 B2 7/1998
CA 2169857 A1 3/1995

(Continued)

OTHER PUBLICATIONS

Examination Report from corresponding European patent application No. 10 824 802.2, dated Jan. 28, 2015, 6 pgs.

(Continued)

Primary Examiner — Timothy J. Kugel
(74) *Attorney, Agent, or Firm* — Chernoff, Vilhauer, McClung & Stenzel, LLP

(57) **ABSTRACT**

A soft contact lens for fitting to a cornea includes a lens main body made of a light permeable member. The lens main body has a diameter larger than that of a light-shielding portion which shields incident light incident to the cornea. The light-shielding portion includes a main body constituting a light-shielding member, an aperture that allows incident light to be transmitted, the aperture being positioned on a position of the main body of the light-shielding portion, and multiple holes that maintain a scotopic vision and a night vision, the holes being provided around the aperture in the main body of the light-shielding portion and each of the holes having a diameter smaller than that of the aperture.

47 Claims, 5 Drawing Sheets

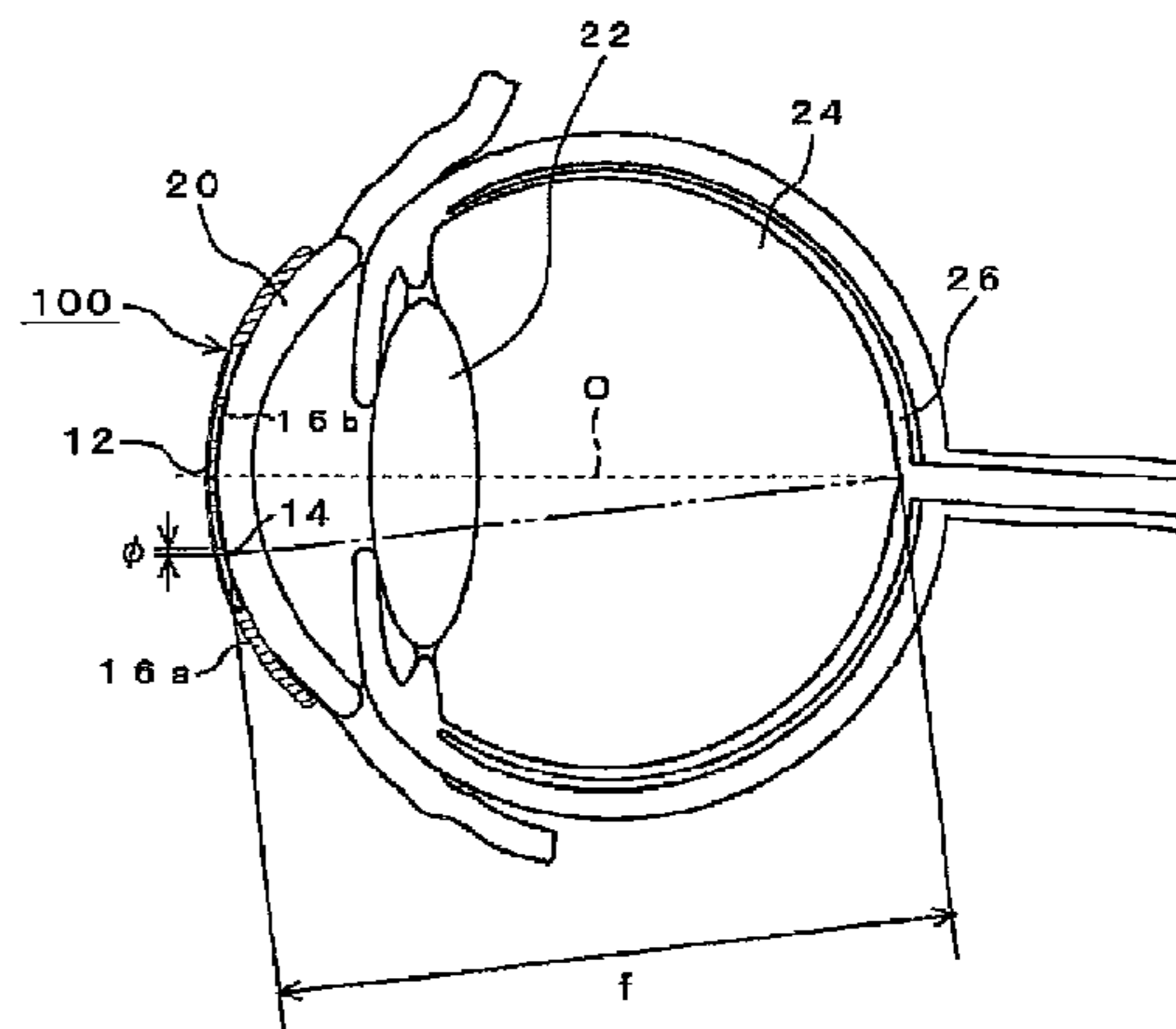
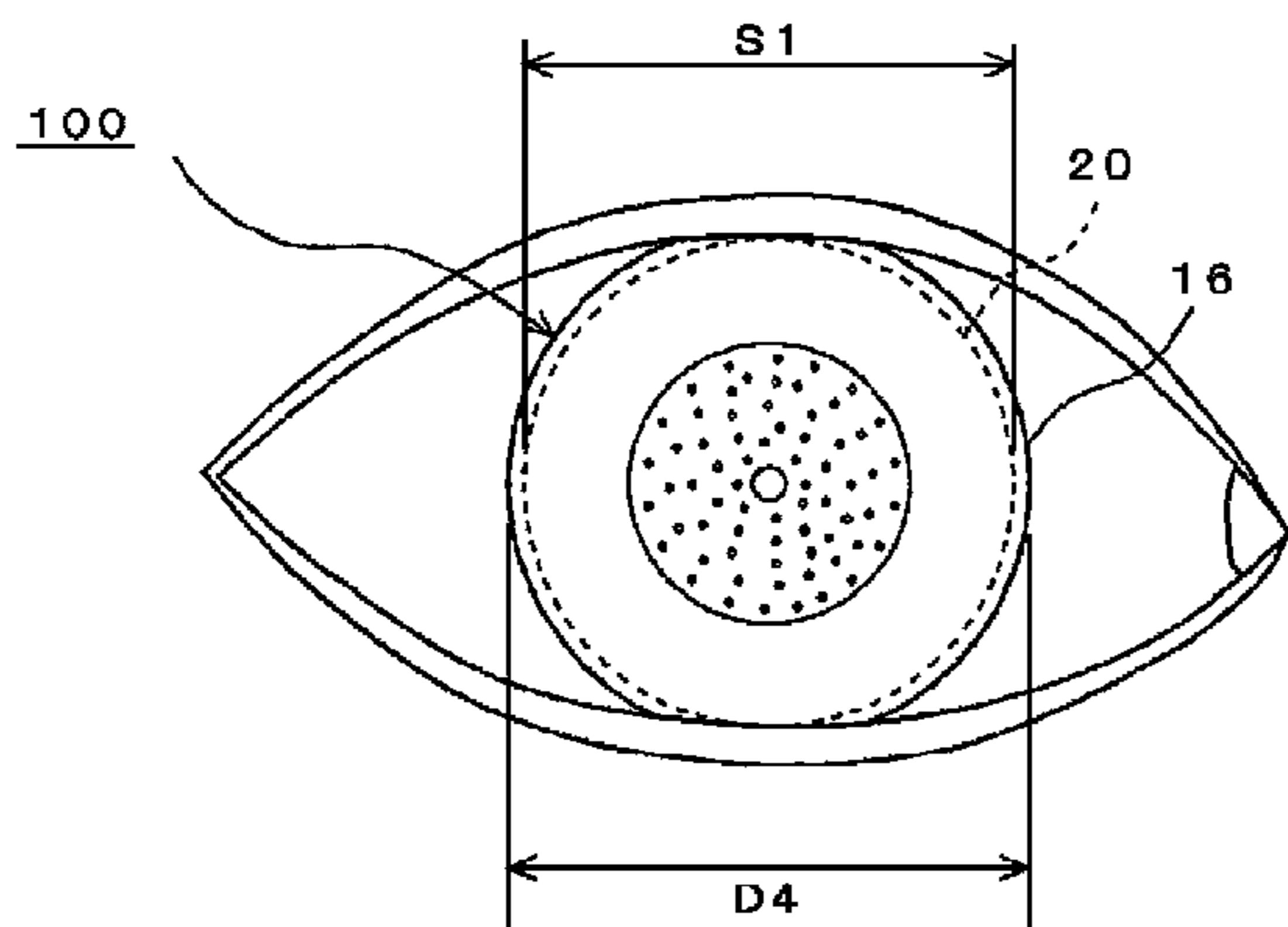

(56)

References Cited

U.S. PATENT DOCUMENTS

5,719,656	A *	2/1998	Bowling	351/159.02
5,757,458	A	5/1998	Miller	351/159.02
5,786,883	A	7/1998	Miller		
5,905,561	A *	5/1999	Lee et al.	623/6.31
6,036,314	A *	3/2000	Wolfson	351/159.02
6,283,595	B1	9/2001	Breger		
6,585,377	B2 *	7/2003	Ortega et al.	351/243
7,491,350	B2 *	2/2009	Silvestrini	264/1.1
2002/0075447	A1	6/2002	Andino		
2005/0033420	A1	2/2005	Christie et al.		
2005/0168688	A1	8/2005	Doshi et al.		
2006/0118263	A1	6/2006	Silvestrini		
2007/0258041	A1 *	11/2007	Huang	351/159
2008/0002149	A1 *	1/2008	Fritsch et al.	351/161

FOREIGN PATENT DOCUMENTS

EP	0724745	A1	8/1996
EP	1337890	A1	8/2003
JP	8029740	A	2/1996
JP	H08-29740	A	2/1996
JP	H09502542	A	3/1997

JP	11242191	A	9/1999
JP	H11-242191	A	9/1999
JP	2004510199	A	4/2004
JP	2007-516019	A	6/2007
WO	95/08135	A1	3/1995
WO	0227388	A1	4/2002
WO	2004105588	A2	12/2004
WO	2014058205		4/2014

OTHER PUBLICATIONS

Rakow, P. L. (2001) "The Road to Presbyopic Contact Lens Success: The Development of Multi focal Rigid Lenses," Eye Witness, Contact Lens Society of America, located at http://www.clsa.info/PDF/4Q_01p11-15.pdf, last accessed on Dec. 18, 2013, pp. 1-4.

European Patent Office, European Search Report in application No. 10824802.2.

State Intellectual Property Office of P.R. China, Notification of First Office Action in application No. 201080047576.3, Mar. 6, 2013.

New Zealand Intellectual Property Office; First Examination Report in application No. 599267, Dec. 12, 2012.

European Patent Office, European Search Report in application No. 10824802.2, Nov. 29, 2012.

International Search Report for PCT/JP2010/067592, Nov. 9, 2010.

* cited by examiner

FIG.1

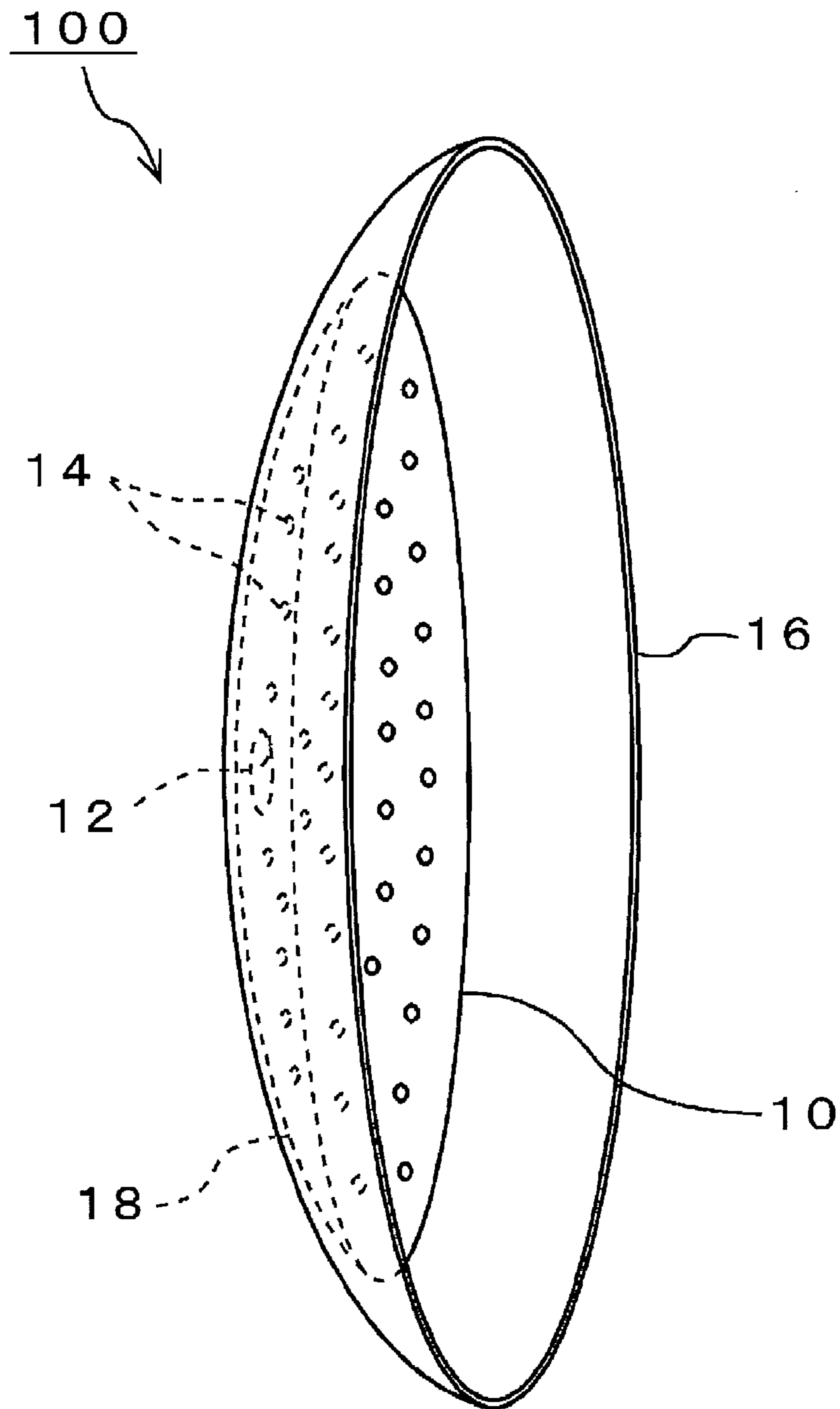

FIG.2

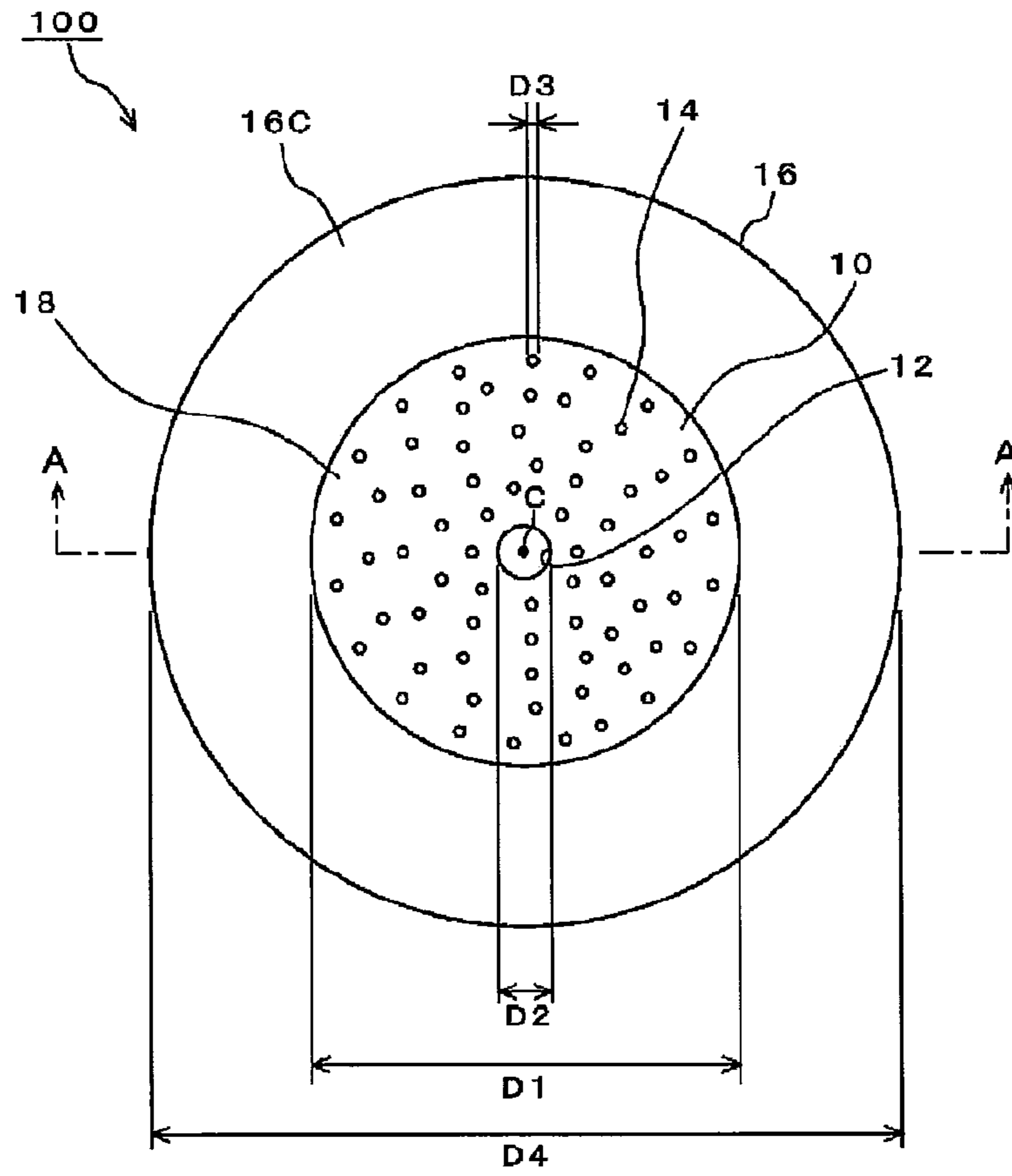

FIG.3

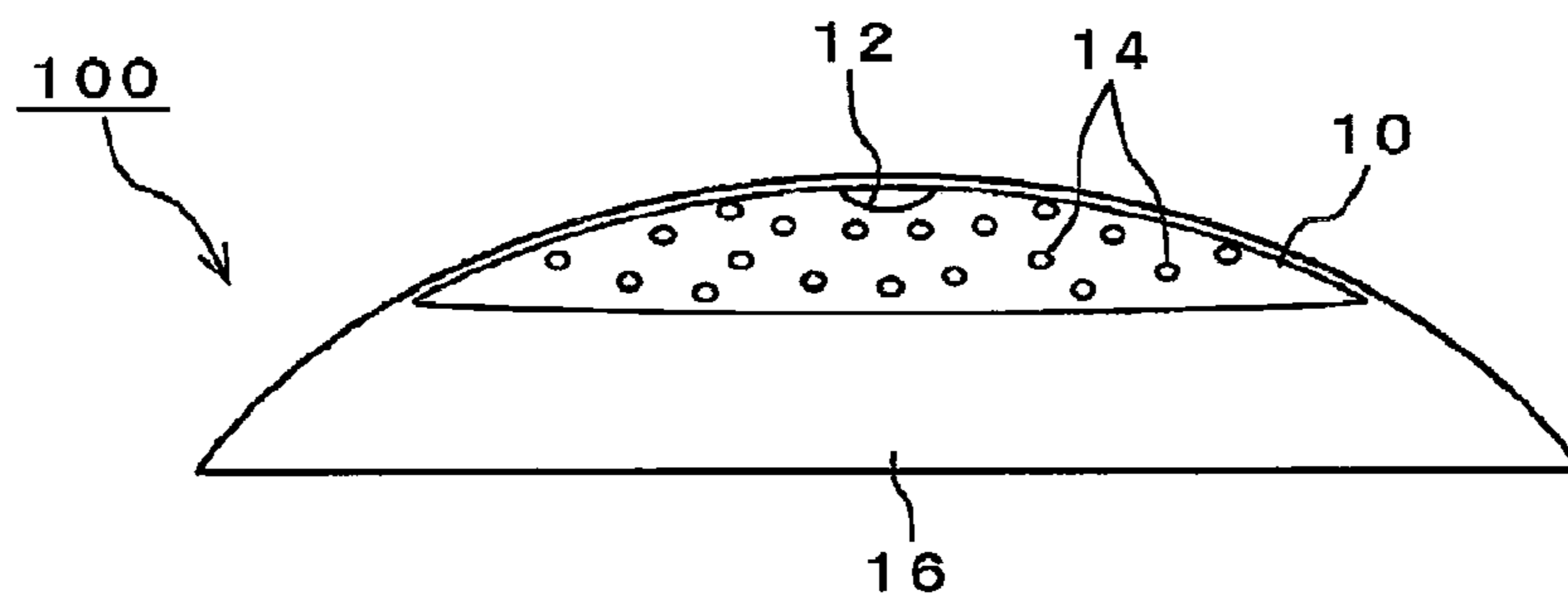

FIG.4A

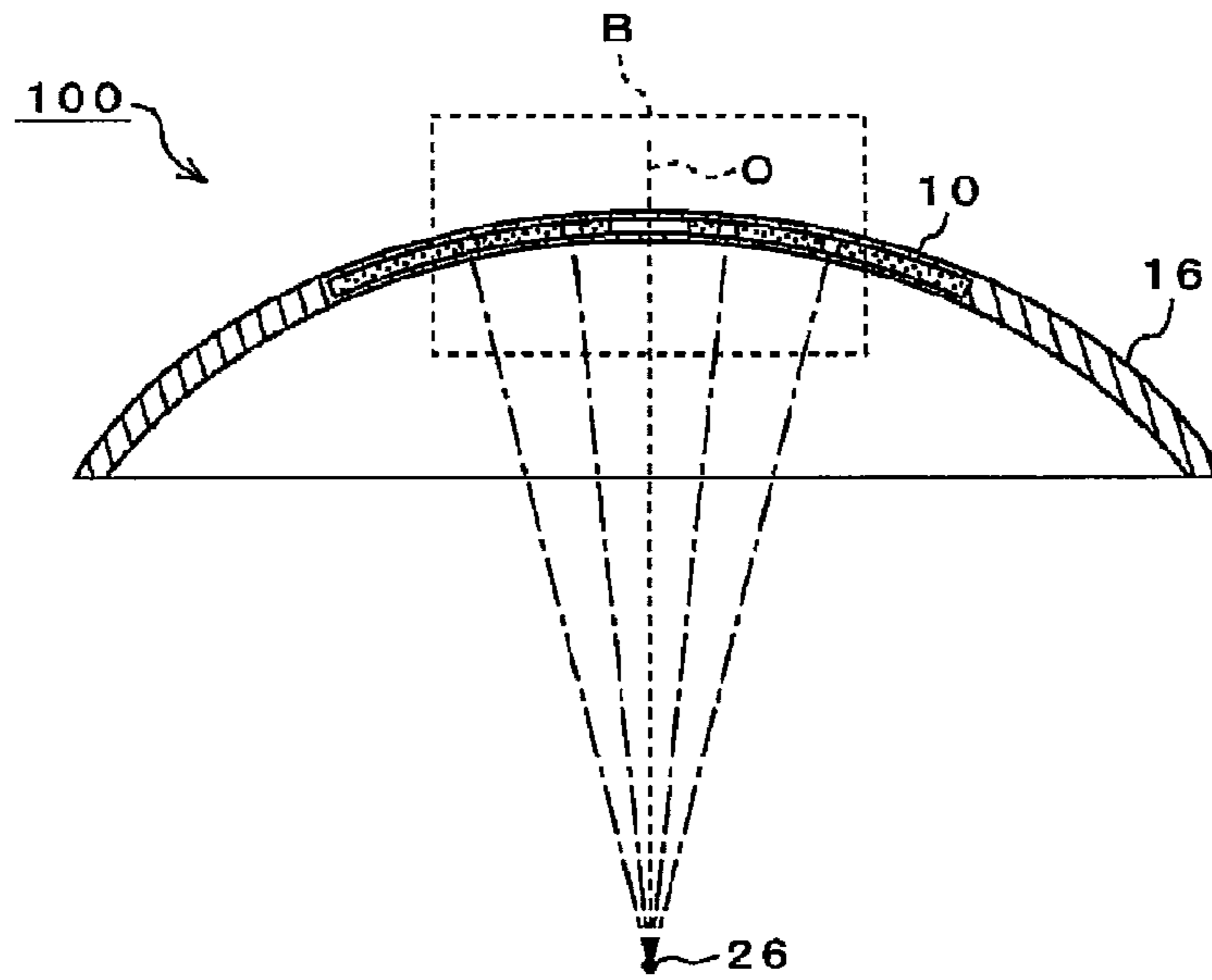

FIG.4B

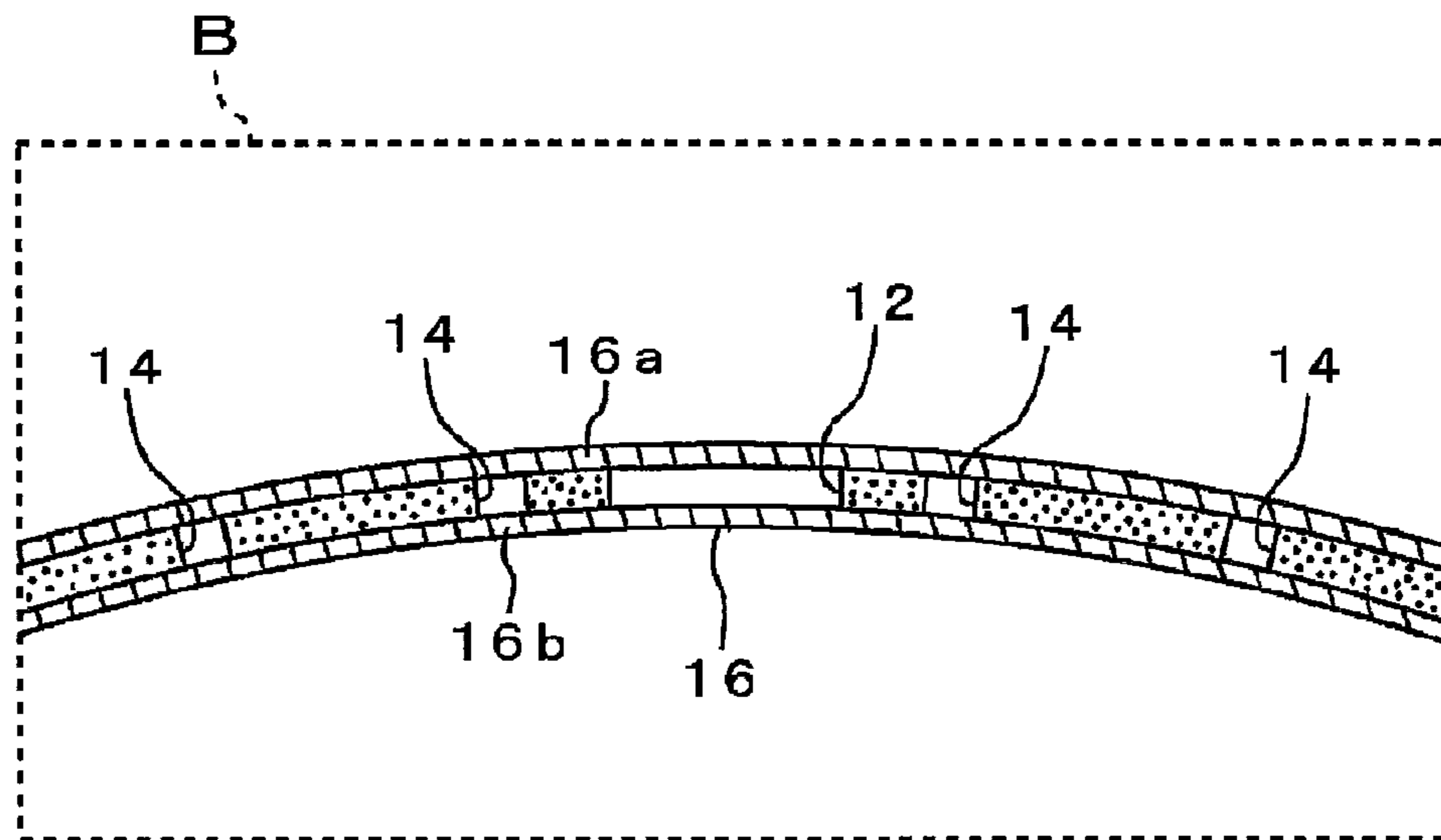

FIG.5

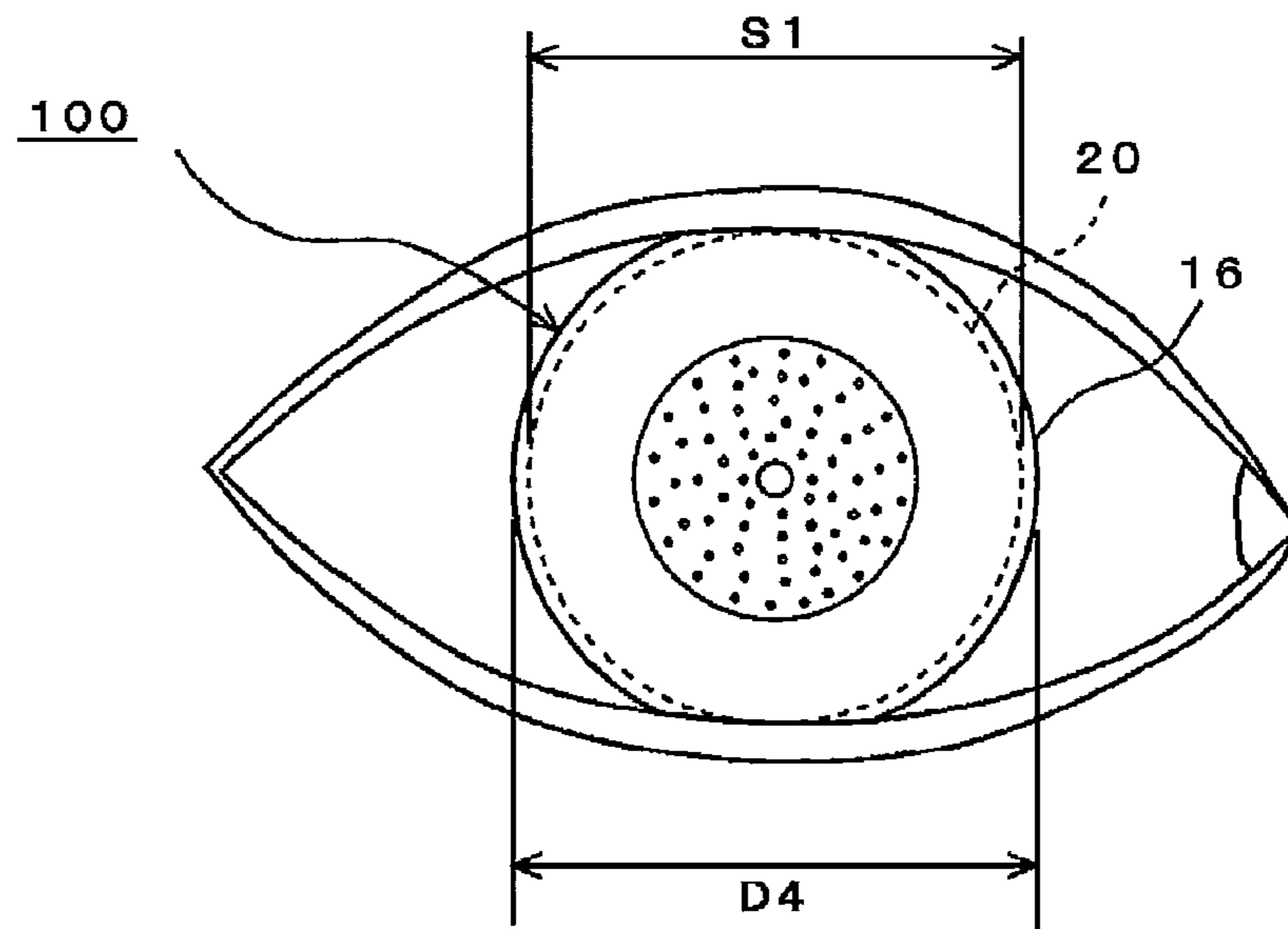

FIG.6

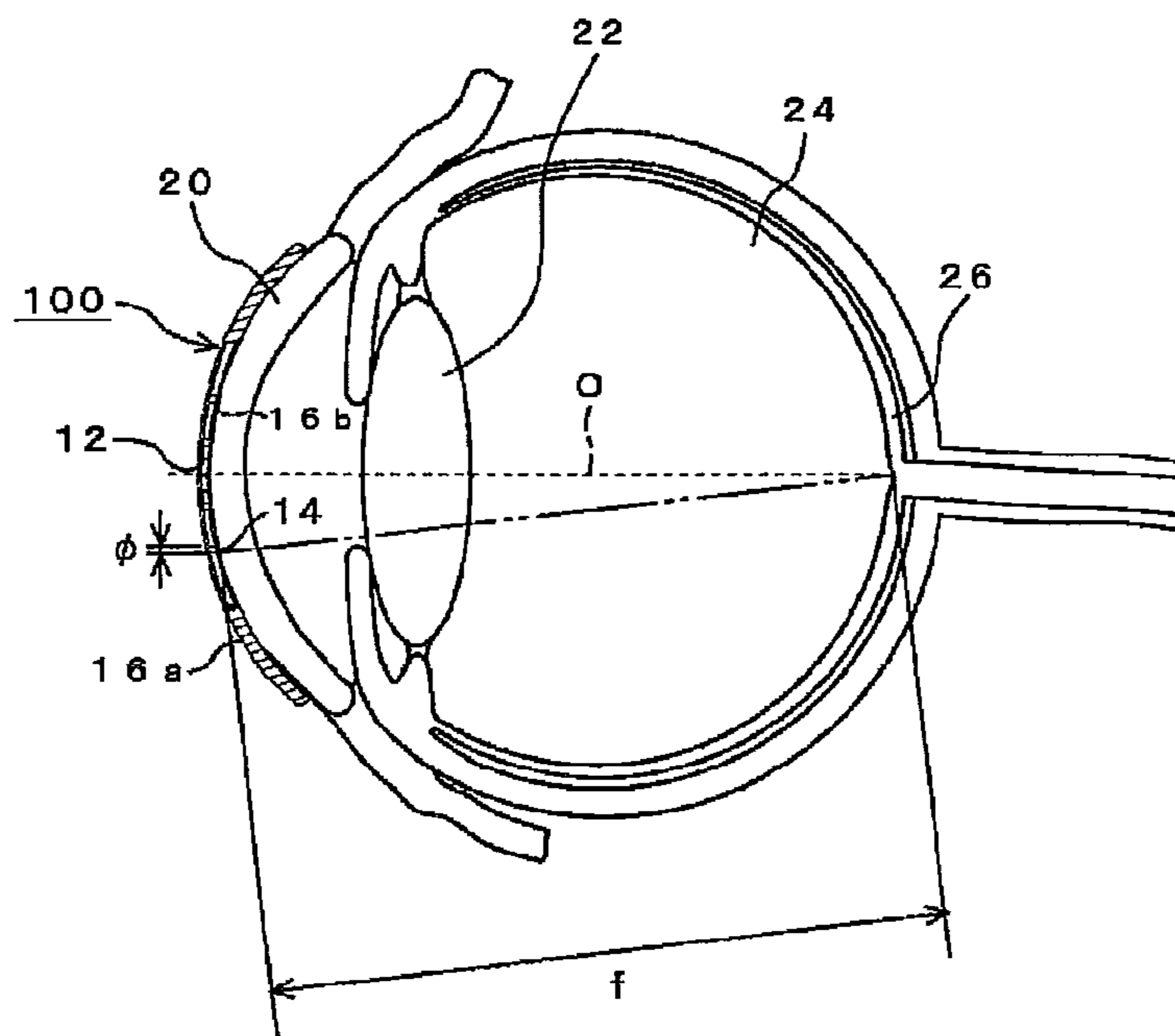

FIG.7A

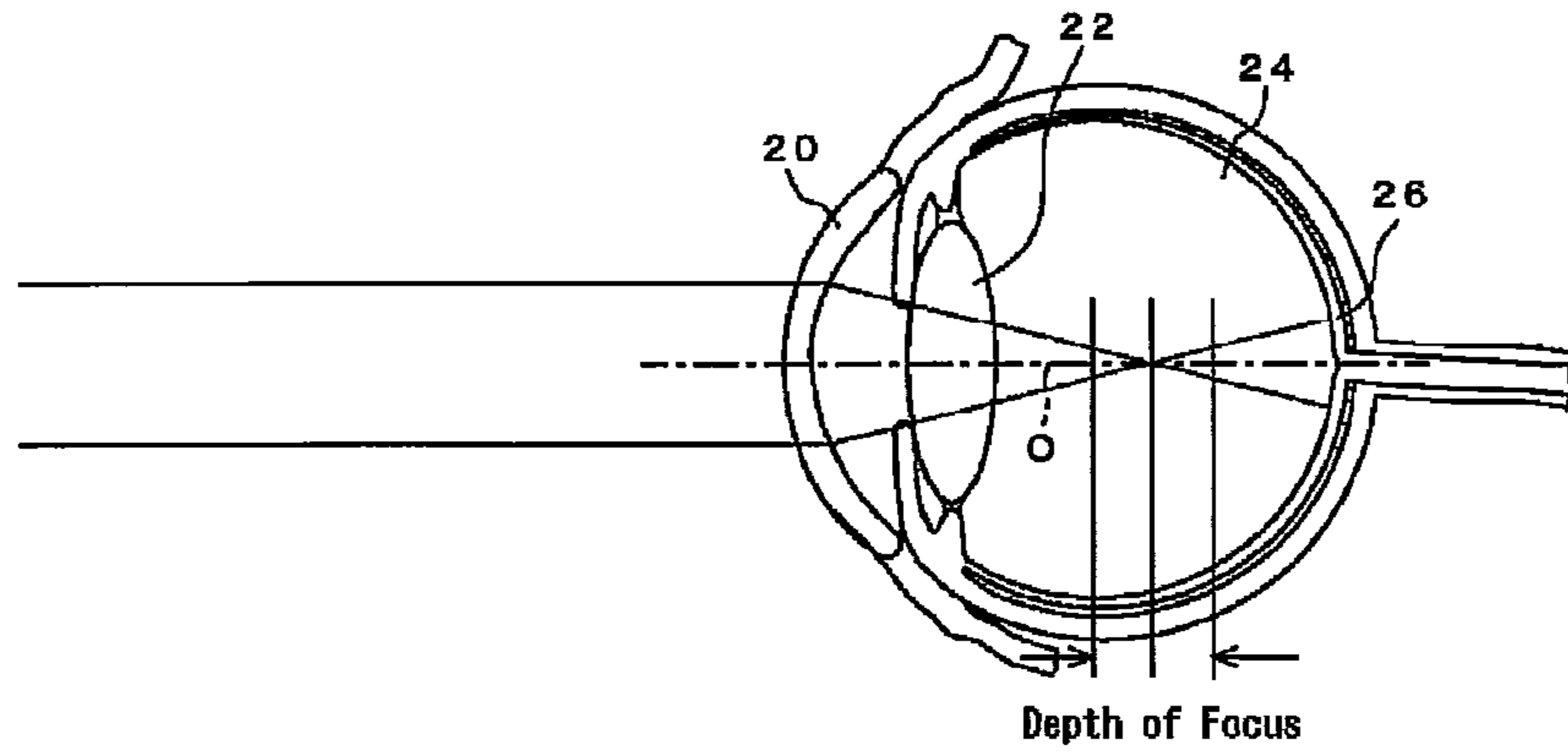

FIG.7B

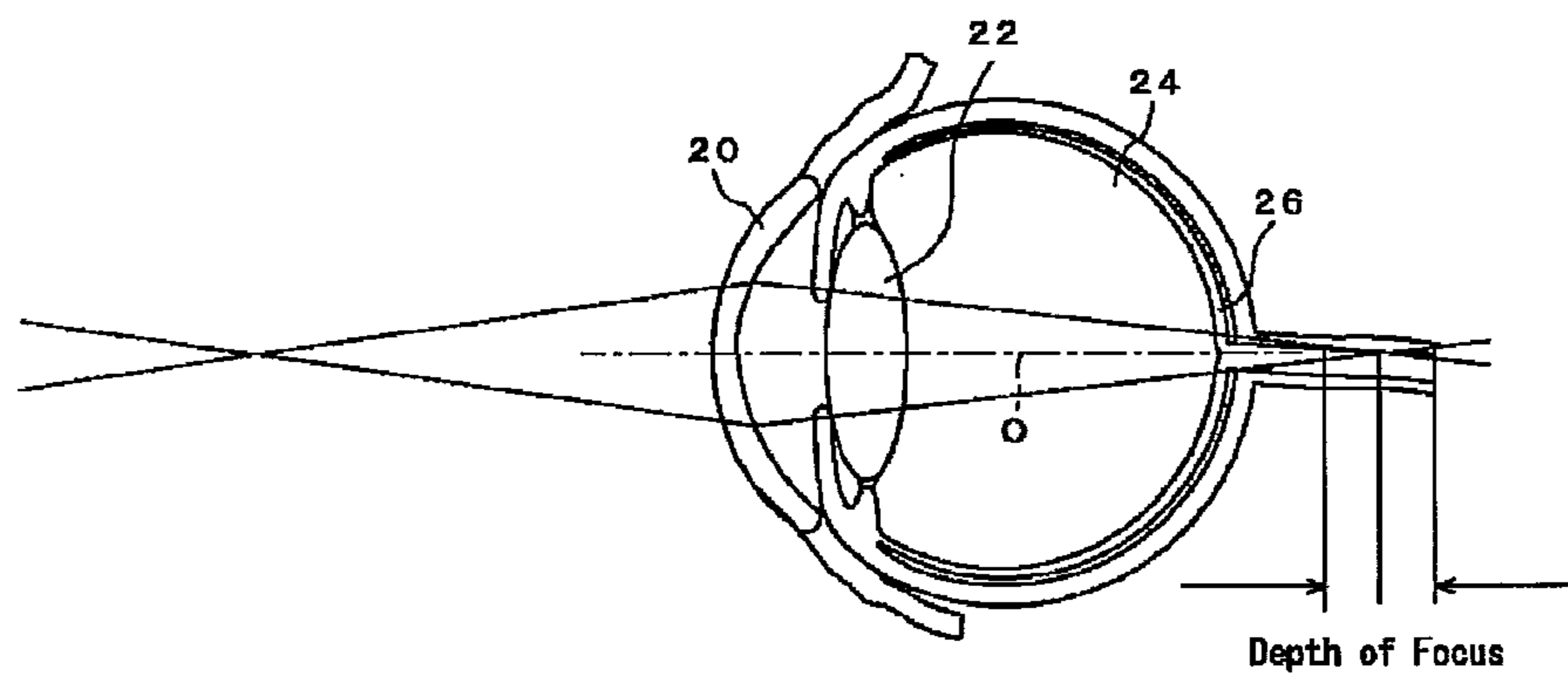
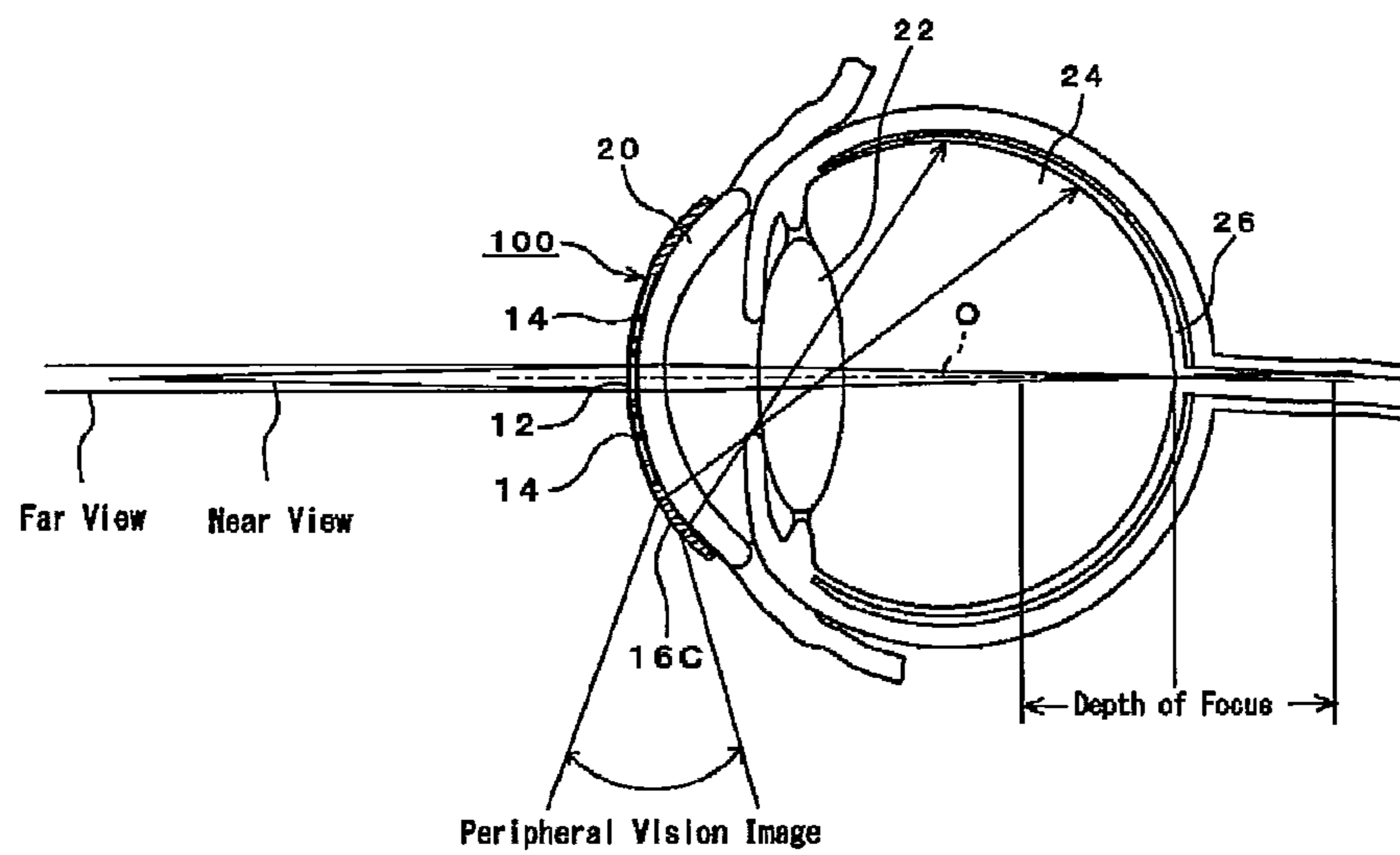

FIG.8



SOFT CONTACT LENS

Matter enclosed in heavy brackets [] appears in the original patent but forms no part of this reissue specification; matter printed in italics indicates the additions made by reissue; a claim printed with strikethrough indicates that the claim was canceled, disclaimed, or held invalid by a prior post-patent action or proceeding.

This is a national stage application filed under 35 USC 371 based on International Application No. PCT/JP2010/067592 filed Oct. 6, 2010, and claims priority under 35 USC 119 of Japanese Patent Application No. 2009-241769 filed Oct. 20, 2009.

TECHNICAL ART

This invention relates to a soft contact lens which is used with it being fitted to a cornea. Particularly, it relates to one such that by making a pinhole in a center of a light-shielding portion that shields light, it is available for any correction of myopia, hyperopia, astigmatism and presbyopia utilizing a depth of focus by the pinhole and by piercing a plurality of fine holes around the pinhole, it is capable of maintaining a night vision in a periphery of an image.

TECHNICAL BACKGROUND

An image of a subject which a person sights is confirmed as a vision so that light of the subject to be incident to a cornea is refracted by the cornea and an eye lens to enter a vitreous body and it is focused on a retina which exists on a back surface side of the vitreous body, thereby sending the focused visual information to cerebrum via optic nerve. In this moment, when the light of the subject is focused on a position in front of or behind the retina, myopia or hyperopia occurs. Further, when the cornea or the eye lens is distorted, it is not focused on the retina, which causes the astigmatism.

As means for correcting such myopia, hyperopia, astigmatism and the like, a correction by a pair of glasses, a correction by a contact lens or the like has been widely performed. Further, for a correction of presbyopia, bifocal glasses (bifocal lens) or the like in which there are a portion for far viewing and a portion for close viewing in one lens have been utilized.

Additionally, as a technology for correcting the presbyopia securely, a mask configured to be implanted in a cornea of a patient has been proposed, which includes an anterior surface that resides adjacent a first corneal layer, a posterior surface that resides adjacent a second corneal layer, a plurality of holes extending at least partially between the anterior surface and the posterior surface, an aperture configured to transmit along an optic axis substantially all incident light and a substantially opaque portion surrounding at least a portion of the aperture (see a patent document 1 followed).

PRIOR ART

Patent Document

[Patent Document 1] Japanese Patent Translation Publication No. 2007-516019 (corresponding to WO2004/105588)

SUMMARY OF THE INVENTION

Problem to be Solved by the Invention

However, in the mask disclosed in the patent document 1, it has a problem such that since the mask is configured to be

implanted in a cornea of a patient, any surgical operation is required, which make it difficult that a user can use the mask easily and safely like a generally used contact lens that is fitted to a cornea. Further, it has a problem such that since the plurality of holes in the mask is provided for preventing a substantial nutrient depletion in the corneal layer, the mask configured by an opaque member without the aperture cannot maintain a sufficient amount of light (up to a night vision) in a periphery of an image even if a small amount of light is incident via the holes for transporting the nutrient.

Thus, this invention, to solve the above-mentioned problems, has an object to provide a soft contact lens which maintains a sufficient amount of light in a periphery of an image and is able to be available for a correction of myopia, hyperopia, astigmatism, presbyopia and the like.

Means for Solving the Problems

In order to solve the above-mentioned problems, a contact lens according to this invention is a soft contact lens which is fitted to a cornea, the soft contact lens comprising a light-shielding portion which shields incident light that is incident to the cornea, and a lens main body made of a light permeable member that allows incident light to be transmitted, the lens main body having a diameter larger than that of the light-shielding portion and covering a front surface of the light-shielding portion and a back surface thereof, wherein the light-shielding portion contains a main body of the light-shielding portion which is made of a light-shielding member, an aperture that allows the incident light to be transmitted, the aperture being positioned on a position of the main body of the light-shielding portion, the position including an optical axis extending to a center of the cornea and a center of a retina, and a plurality of holes that maintains a scotopic vision and a night vision, the holes being provided around the aperture in the main body of the light-shielding portion and each of the holes having a diameter smaller than that of the aperture.

When the soft contact lens according to this invention is fitted to the cornea, an image (light) is passed through a front surface of the lens, a pinhole and a back surface of the lens to be incident to the cornea. The image that is incident to the cornea enters an eye lens and a vitreous body inside an eye ball through the cornea and a pupil of the eye and is focused on the retina at a back side of the vitreous body. In this moment, as a beam is limited to a constant amount by a pinhole formed in the light-shielding portion, the image is always focused on the retina even when seeing a distant place or seeing a close place.

Light surrounding the pinhole is incident via a plurality of fine holes pierced around the pinhole and is focused on the retina through the cornea, the vitreous body and the like. This enables brightness surrounding the image to be kept. Further, the images of the pinhole and in a periphery of the light-shielding portion are transmitted to a light transmission portion (a lens main body) provided around the light-shielding portion, are incident to the cornea, enter the vitreous body inside the eyeball through the pupil of the eye and are focused on the retina at a back surface side of the vitreous body. This enables a peripheral vision in a periphery of the image to be kept, thereby allowing a vision which is similar to that of the naked eye to be obtained.

Effect of the Invention

According to the invention, it is possible to provide a soft contact lens which, by making a pinhole in a center of a

light-shielding portion that shields incident light, is available for any correction of myopia, hyperopia, astigmatism and presbyopia utilizing a depth of focus by the pinhole. Further, according to the invention, by piercing a plurality of fine holes around the pinhole, it is capable of maintaining a sufficient night vision (brightness) in a periphery of the image with maintaining any light-shielding mechanism.

BRIEF DESCRIPTION OF THE DRAWING

FIG. 1 is a perspective view of a soft contact lens according to one embodiment of this invention showing a configuration example thereof.

FIG. 2 is a plan view of the soft contact lens showing a configuration example thereof.

FIG. 3 is a side view of the soft contact lens showing a configuration example thereof.

FIG. 4A is a cross sectional view of the soft contact lens, taking along the lines A-A shown in FIG. 2.

FIG. 4B is an enlarged view of an important portion B, which is enclosed by dotted line shown in FIG. 4A, in the soft contact lens.

FIG. 5 is a diagram showing a state (No. 1) where the soft contact lens is fitted to a cornea.

FIG. 6 is a diagram showing a state (No. 2) where the soft contact lens is fitted to the cornea.

FIG. 7A is a diagram illustrating a depth of focus when seeing a distant place.

FIG. 7B is a diagram illustrating a depth of focus when seeing a close place.

FIG. 8 is a diagram illustrating a depth of focus when seeing a distant place and seeing a close place.

EMBODIMENTS FOR CARRYING OUT THE INVENTION

The following will describe a best mode for carrying out the invention (hereinafter, referred to as "embodiment").

Configuration Example of Soft Contact Lens

A soft contact lens **100** according to the invention is available for any correction of low-level myopia, hyperopia, astigmatism and presbyopia utilizing a depth of focus by the pinhole **12** made in a center of a light-shielding portion **10** and maintains a night vision (brightness) in a periphery of an image by piercing a plurality of fine holes **14** around the pinhole **12**. This soft contact lens **100** is provided with the light-shielding portion **10** which shields light that is incident to the cornea **20** and a lens main body **16** supporting the light-shielding portion **10**, as shown in FIGS. 1 through 4A.

The light-shielding portion **10** contains a main body **18** of the light-shielding portion, the pinhole **12** and a plurality of holes **14**. The main body **18** of the light-shielding portion is a member having a shape having a curved surface so that it is parallel to a shape of a surface of the cornea **20** and showing a circle seen from a plane (see FIG. 6) and is made of a light-shielding member which shields light that is incident to the cornea **20**. As material for the main body **18** of the light-shielding portion, any material which has been used in a soft contact lens with an iris and has already ensured safety is preferably used. For example, an azo coloring agent (red) or a phthalocyanine coloring agent (blue) can be used. A thickness of the main body **18** of the light-shielding portion is preferably set as thin as possible to prevent a light beam to a periphery of the lens (a light-transmitting portion **16C** which will be described) from being shielded.

A diameter **D1** of the main body **18** of the light-shielding portion is set to be, for example, within a range of 4.0 mm through 9.0 mm, taking into consideration a diameter of a pupil of the eye when the pupil of the eye is dilated (a dimension of the pupil of the eye in the darkness), which varies according to the aging. This is because if the diameter **D1** of the main body **18** of the light-shielding portion is less than 4.0 mm, an area of the light-transmitting portion **16C** (see FIG. 2), which will be described later, around the main body **18** of the light-shielding portion becomes larger so that a peripheral vision becomes wider but if a diameter of the pupil of the eye is larger than that of the light-shielding portion **10** during the night or the like, peripheral light without the light-shielding portion **10** enters a central part of the retina **26** so that a halo phenomenon or a glare occurs. This is also because if the diameter **D1** of the main body **18** of the light-shielding portion exceeds 9.0 mm, an area of the light-transmitting portion **16C** which transmits light that is incident to the lens main body **16** becomes smaller so that a peripheral vision cannot be maintained. In other words, this is because a vision (eyesight) that is similar to that of the naked eye cannot be maintained.

The pinhole **12** is an example of an aperture and made at a center position **C** of the main body **18** of the light-shielding portion, the position including an optical axis (eye axis) **O** extending to the cornea **20** and the retina **26**. A hole shape of the pinhole **12** is preferably an accurate circle to prevent incident light from diffracting. Further, the pinhole **12** has a function to limiting flux of light that is incident to the cornea **20** to a constant amount thereof so that an image is focused on the retina **26** and takes effect corresponding to that by added dioptric power of multipoint lens based on a size of a diameter **D2** of the pinhole **12**.

As the diameter **D2** of the pinhole **12**, it is set to be within a range of, for example, 1.0 mm through 1.6 mm. It was understood that when altering the diameter **D2** of the pinhole **12** within a range of 1.0 mm through 1.6 mm, a near vision was obtained corresponding to the added dioptric power of about 1.00 D through 3.00 D based on a variation in the size of the diameter thereof. Further, it was not capable of obtaining an optimal near vision when setting the diameter **D2** of the pinhole **12** to be less than 1.0 mm or more than 1.6 mm. As the reason thereof, it is understood that as shown in the drawings, a depth of focus is deeper by changing the flux of light even in a non-dioptic lens.

The plurality of holes **14** is pierced in the main body **18** of the light-shielding portion between an outer periphery thereof and a rim of the pinhole **12** at random or regularly as shown in FIG. 2, and has a function to maintain brightness (night vision) by allowing light from outside to be incident to the cornea **20**. Particularly, when using the soft contact lens **100** in the night or the darkness, they are effective for maintenance of an amount of light. The narrower the pitch between the holes **14** becomes, any sufficient brightness may be maintained. On the other hand, the broader the pitch between the holes **14** becomes, an improvement in a contrast of the image can be attempted.

Further, a shape of each of the holes **14** is preferably an accurate circle to prevent incident light from diffracting. A depth direction (a passing-through direction) of each of the pinholes **14** is inclined toward the retina **26** (along an alternate long and short dash line) as shown in FIG. 4A so that it can focus incident light on the retina **26** effectively.

A diameter **D3** of each of the holes **14** is set so as to be smaller the diameter of the pinhole **12** and is set so to be within a range of, for example, 0.17 mm through 0.18 mm. This is because when it is set to be less than 0.17 mm, the diameter of each of the holes **14** is too small to gather the

5

incident light therein enough, which disables any night vision (brightness) to be maintained. This is also because when it is set to be more than 0.18 mm, the diameter of each of the holes **14** is too larger so that a halo or a glare phenomenon occurs by a diffraction of light.

Here, the optimal diameter D_3 of each of the holes **14** may be get from a relationship between a focal distance from the cornea **20** to the retina **26** and a wavelength of light. As shown in FIG. 6, if a diameter of each of the holes **14** is h , a wavelength of light is λ , a distance from the cornea **20** to the retina **26** (a length of eye axis) is a focal distance f , the diameter h of each of the holes **14** is obtained by the following equation (1).

(Equation (1))

$$\begin{aligned} \phi &= \sqrt{2\lambda f} \\ &= 0.03679\sqrt{f} \end{aligned} \quad (1)$$

Here, the focal distance f is generally within a range of 23 mm through 24 mm so that when a numeral value of f , for example, 23 mm is substituted for the equation (1), 0.176 mm is obtained as the optimal diameter h of each of the holes **14**. Further, when a numeral value of 24 mm as the focal distance is substituted for the equation (1), 0.180 mm is obtained as the optimal diameter ϕ of each of the holes **14**.

The lens main body **16** is a member having a shape having a curved surface (curvature) so that it is parallel to a shape of a surface of the cornea **20** and showing a circle seen from a plane and is made of a light-permeable member which can transmit incident light. As a material of the lens main body **16**, hydroxy ethyl methacrylate (HEMA), N-vinylpyrrolidone (N-VP), dimethylacrylamide (DMAA), glycerol methacrylate (GMA), silicone hydrogel (SH) and the like, which are used as hydrous soft contact lens, are preferably used. Further, as a material of the lens main body **16**, silicone rubber, butylacrylate and dimethylsiloxane lens, which are used as non-hydrous soft contact lens and hydrous soft contact lens, are preferably used. It is to be noted that any colored material such as red or blue one may be used when it can transmit the light even if not transparent.

The lens main body **16** is used as a replacement type soft contact lens or a disposable type soft contact lens. When a person has a slight extent of myopia, hyperopia or astigmatism, it is considered that a far vision or a near vision or both thereof can be obtained even if any dioptric power is not added. In the other case, a dioptric power of the lens may be added to the lens main body **16** on the basis of a condition of user's myopia or hyperopia. The lens main body **16** positioned around the main body **18** of the light-shielding portion functions as light-transmission portion **16C** for maintaining a peripheral vision by gathering incident light into the cornea **20** as shown in FIG. 2.

A diameter D_4 of the lens main body **16** is larger than the diameter D_1 of the main body **18** of light-shielding portion and as shown in FIG. 5, is at least set so to be larger than a diameter S_1 (for example, 12 mm) of the cornea **20**, for example, about 14 mm. This is because if the diameter D_4 of the lens main body **16** is smaller than the diameter of cornea, the lens extremely moves on the cornea **20** so that a center of the cornea **20** is excessively shifted to a center C of the main body **18** of light-shielding portion, which disables a stable vision to be maintained. Further, this is because if the diameter D_4 of the lens main body **16** is set to be larger than 14 mm, it is difficult to fit the lens main body **16** on the cornea **20**. The lens main body **16** having such a diameter is configured so as

6

to be united to the main body **18** of light-shielding portion with it holding (covering) a front surface and a rear surface of the main body **18** of light-shielding portion by a front surface portion and a rear surface portion constituting the lens main body **16**.

The following will describe a disposition or position of the light-shielding portion **10** constituting the soft contact lens **100** according to the invention with it being compared with the existing soft contact lens with the iris. First, the existing soft contact lens with the iris will be described. A colored portion (corresponding to the light-shielding portion **10** of this invention) of the existing soft contact lens with the iris may be disposed (colored) on a front surface or a rear surface of the lens so as to be exposed. However, if the colored portion is disposed on the front surface of the lens, roughness of a surface of the colored portion, which is made of a material that is different from that of the lens main body, contacts a palpebral conjunctiva (a rear side of an eyelid) so that a friction on the front surface of the lens becomes larger as compared with that of the rear surface of the lens. Accordingly, it has such a problem that in a moment of the blink of an eye, the lens main body extremely moves based on the friction of the palpebral conjunctiva and the colored portion and thus a center axis of the soft contact lens is excessively shifted from a center of the cornea (optical axis), which causes the soft contact lens to be used under unstable condition. On the contrary, if the colored portion is disposed on the rear surface of the lens, a friction on the rear surface of the lens becomes larger as compared with that of the front surface of the lens so that the colored portion of the lens main body is subject to becoming fixed to the cornea, which may cause any problems on a safety.

Accordingly, in the soft contact lens **100** according to the invention, as shown in FIGS. 4A and 4B, the light-shielding portion **10** is held between the front surface and the rear surface of the lens main body **16** so that the light-shielding portion **10** is embedded in the lens main body **16**. In other words, by positioning the light-shielding portion **10** at about a center of the lens main body **16** on its thickness direction, it is configured so that the light-shielding portion **10** is not exposed outward. This prevents extra friction from occurring at the front surface portion and the rear surface portion of the lens main body **16**, which can avoid shifting the soft contact lens **100** from the optical axis to allow a stable vision to be maintained. Further, this prevents the lens main body **16** from being fixed to the cornea, which allows a safety to be maintained.

Functional Example of the Soft Contact Lens

The following will describe a functional example when fitting the soft contact lens **100** according to this embodiment to an eyeball. First, a general depth of focus in cases where a myope looks into the distance and a presbyope looks a near position will be described. As shown in FIG. 7A, when the myope looks into the distance, light that is incident to the eyeball is focused in front of the retina **26**, not on a correct position of the retina **26**. Further, since the depth of focus is also inadequate, it is in front of the retina **26**. Further, as shown in FIG. 7B, when the presbyope looks a near position, the eye lens **22** loses elasticity and is stiff so that it is focused behind the retina **26**, not on a correct position of the retina **26**.

On the other hand, when fitting the soft contact lens **100** according to this embodiment on the cornea **20**, an image (light) is incident to the cornea **20** via a front surface portion **16a**, the pinhole **12** and a rear surface portion **16b** as shown in FIG. 8. The image that is incident to the cornea **20** enters a

vitreous body **24** inside the eyeball through the cornea **29**, the pupil of eye and the eye lens **22** and is focused on the retina **26** at the rear surface side of the vitreous body **24**. In this moment, since an amount (rate) of the light that is incident into the eyeball through the pinhole **12** is not spread but limited to a constant amount thereof, an image is always focused on the same position of the retina **26** even when looking into the distance or looking a near position. Thus, since by using the soft contact lens **100**, it is possible to meet a focal position on the retina **26** for any person with a mild myopia or hyperopia, astigmatism or presbyopia, it is available for any correction of the mild myopia or hyperopia, astigmatism or presbyopia.

Additionally, as shown in FIG. 8, light is also incident to a plurality of fine holes **14** pierced around the pinhole **12** and is focused on a position, which corresponds to a periphery of the image by the pinhole, of the retina **26** through the cornea **20**, the eye lens **22**, the vitreous body **24** and the like, thereby allowing a night vision (brightness) in the periphery of the image to be maintained. *The holes 14 are distributed about the pinhole 12 at a plurality of different radial distances.* Further, a peripheral image by the pinhole **12** and the light-shielding portion **10** is penetrated into the light-transmitting portion **16C** provided around the light-shielding portion **10**, is incident to the cornea **20**, enters the vitreous body **24** inside the eyeball through the pupil of the eye and is focused on the retina **26** at a rear surface side of the vitreous body **24**. This enables a peripheral vision in a periphery of the image obtained by the pinhole **12** to be maintained, thereby allowing a field of vision that is similar to that of the naked eye to be obtained.

As described above, according to this embodiment, since the soft contact lens **100** utilizes a depth of focus by the pinhole **12**, it is possible to look a near point by a minimum required control power of the eye lens **22**. Further, when any dioptric power for myopia is not added to the lens main body **16**, a burden is reduced even when working at the near point is performed. Further, in addition to the near point, this is effective to a hyperopia to which the control power of the eye lens **22** is required.

Further, according to the embodiment, since by adapting the pinhole **12**, only the very narrow region of the cornea **20** is used as a vision, the soft contact lens **100** can be used even in a case of corneal astigmatism and corneal irregular astigmatism so that it is possible to apply the embodiment effectively to the astigmatism. It is also possible to obtain an effect that is equal to an added dioptric power for presbyopia by setting the diameter D_2 of the pinhole **12** so as to be within a range of 1.0 mm through 1.6 mm and is possible to obtain a near vision corresponding to an added dioptric power for a multifocal lens.

Additionally, according to the soft contact lens **100** of this embodiment, it is possible to add dioptric power for myopia or hyperopia to the lens main body **16** when necessary and it is possible to add no dioptric power to the lens main body **16**. If no dioptric power is added to the lens main body **16**, an epoch-making soft contact lens **100** which can realize a near vision without victimizing a far vision like bifocal lens may be provided.

According to this embodiment, by piercing a plurality of fine holes **14** around the pinhole **12**, it is also possible to maintain a light-shielding function (a contrast for the image) and maintain the night vision (brightness) in a periphery of the image. Since the periphery of the light-shielding portion **10** is composed of the light-transmission portion **16C** from which light is transmitted, it is also possible to maintain a peripheral vision that is similar to that of the naked eye.

Further, according to the soft contact lens **100** of this embodiment, it is possible to correct the presbyopia or the like by fitting the soft contact lens to the cornea **20** like a general contact lens. This enables the presbyopia or the like to be corrected more easily and in safety because it is not required to implant the soft contact lens in the cornea like the mask disclosed in the patent document 1.

It is to be noted that the subject matter contained in this invention is not limited to the above-mentioned embodiment; any variations of the above-mentioned embodiments, to which various kinds of alternations are added, are also contained without deviating from a spirit or concept of this invention. For example, although in the above-mentioned embodiments, shapes of the pinhole **12** and each of the holes **14** have set to be an accurate circle because diffraction of light is avoided, this invention is not limited: For example, any shape such as an ellipse and a rectangular may be adapted.

Description of Codes

100 . . . Soft Contact Lens; **10** . . . Light-shielding Portion; **12** . . . Pinhole; **14** . . . Holes; **16** . . . Lens Main Body; **16C** . . . Light-transmitting Portion; **18** . . . Main Body of Light-shielding Portion; **20** . . . Cornea; **26** . . . Retina; and **O** . . . Optical Axis

The invention claimed is:

1. A soft contact lens which is fitted to a cornea, the soft contact lens comprising:

a light-shielding portion which shields incident light that is incident to the cornea; and

a lens main body made of a light permeable member that allows incident light to be transmitted, the lens main body having a diameter larger than that of the light-shielding portion and covering a front surface of the light-shielding portion and a back surface thereof,

wherein the light-shielding portion contains:

a main body of the light-shielding portion which is made of a light-shielding member;

an aperture that allows the incident light to be transmitted, the aperture being positioned on a position of the main body of the light-shielding portion, the position including an optical axis extending to a center of the cornea and a center of a retina; and

a plurality of holes that maintains a scotopic vision and a night vision, the holes being provided around the aperture in the main body of the light-shielding portion and spaced from said aperture at a plurality of different radial distances, each of the holes having a diameter smaller than that of the aperture.

2. The soft contact lens according to claim 1 wherein a diameter of each of the holes is not less than 0.17 mm and not more than 0.18 mm.

3. The soft contact lens according to claim 2 wherein the diameter of each of the holes is obtained by the following equation:

$$\phi = \sqrt{2\lambda f} \quad [\text{Equation 1}]$$

where the diameter of each of the holes is \hbar , a wavelength of incident light is λ , and a distance from the cornea to the retina is a focal distance f .

4. The soft contact lens according to claim 1 wherein a diameter of the aperture is set to be not less than 1.0 mm and not more than 1.6 mm whereby a near vision corresponding to an added dioptric power for a multifocal lens is obtained, a far vision on myopia or hyperopia is improved and an effect of a correction of astigmatism is obtained.

11

31. The soft contact lens according to claim 13 wherein the lens main body contains a front surface portion and a rear surface portion, and the light-shielding portion is held between the front surface portion of the lens main body and a rear surface portion thereof.

32. The soft contact lens according to claim 14 wherein the lens main body contains a front surface portion and a rear surface portion, and the light-shielding portion is held between the front surface portion of the lens main body and a rear surface portion thereof.

33. The soft contact lens according to claim 15 wherein the lens main body contains a front surface portion and a rear surface portion, and the light-shielding portion is held between the front surface portion of the lens main body and a rear surface portion thereof.

34. The soft contact lens according to claim 16 wherein the lens main body contains a front surface portion and a rear surface portion, and the light-shielding portion is held between the front surface portion of the lens main body and a rear surface portion thereof.

35. The soft contact lens according to claim 17 wherein the lens main body contains a front surface portion and a rear surface portion, and the light-shielding portion is held between the front surface portion of the lens main body and a rear surface portion thereof.

36. The soft contact lens according to claim 18 wherein the lens main body contains a front surface portion and a rear surface portion, and the light-shielding portion is held between the front surface portion of the lens main body and a rear surface portion thereof.

37. A soft contact lens which is fitted to a cornea, the soft contact lens comprising:

a light-shielding portion which shields incident light that is incident to the cornea; and

a lens main body made of a light permeable member that allows incident light to be transmitted, the lens main body having a diameter larger than that of the light-shielding portion and covering a front surface of the light-shielding portion and a back surface thereof,

wherein the light-shielding portion contains:

a main body of the light-shielding portion which is made of a light-shielding member;

an aperture that allows the incident light to be transmitted, the aperture being positioned on a position of the main body of the light-shielding portion, the position including an optical axis extending to a center of the cornea and a center of a retina; and

a plurality of holes that maintains a scotopic vision and a night vision, the holes being provided around the aperture in the main body of the light-shielding portion and each of the holes having a diameter smaller than that of the aperture,

wherein a diameter of each of the holes is not less than 0.17 mm and not more than 0.18 mm.

38. The soft contact lens according to claim 37 wherein the diameter of each of the holes is obtained by the following equation:

$$\Phi = \sqrt{2\lambda f}$$

where the diameter of each of the holes is Φ , a wavelength of incident light is λ , and a distance from the cornea to the retina is a focal distance f .

39. A soft contact lens which is fitted to a cornea, the soft contact lens comprising:

a light-shielding portion which shields incident light that is incident to the cornea; and

12

a lens main body made of a light permeable member that allows incident light to be transmitted, the lens main body having a diameter larger than that of the light-shielding portion and covering a front surface of the light-shielding portion and a back surface thereof,

wherein the light-shielding portion contains:

a main body of the light-shielding portion which is made of a light-shielding member;

an aperture that allows the incident light to be transmitted, the aperture being positioned on a position of the main body of the light-shielding portion, the position including an optical axis extending to a center of the cornea and a center of a retina; and

a plurality of holes that maintains a scotopic vision and a night vision, the holes being provided around the aperture in the main body of the light-shielding portion and each of the holes having a diameter smaller than that of the aperture;

wherein a diameter of the aperture is set to be not less than 1.0 mm and not more than 1.6 mm whereby a near vision corresponding to an added dioptric power for a multifocal lens is obtained, a far vision on myopia or hyperopia is improved and an effect of a correction of astigmatism is obtained.

40. The soft contact lens according to claim 37 wherein a diameter of the aperture is set to be not less than 1.0 mm and not more than 1.6 mm whereby a near vision corresponding to an added dioptric power for a multifocal lens is obtained, a far vision on myopia or hyperopia is improved and an effect of a correction of astigmatism is obtained.

41. The soft contact lens according to claim 37 wherein the diameter of the light-shielding portion is not less than 4.0 mm and not more than 9.0 mm and the diameter of the lens main body is 14.0 mm or so.

42. The soft contact lens according to claim 38 wherein the diameter of the light-shielding portion is not less than 4.0 mm and not more than 9.0 mm and the diameter of the lens main body is 14.0 mm or so.

43. The soft contact lens according to claim 37 wherein the lens main body contains a front surface portion and a rear surface portion, and the light-shielding portion is held between the front surface portion of the lens main body and a rear surface portion thereof.

44. The soft contact lens according to claim 39 wherein the lens main body contains a front surface portion and a rear surface portion, and the light-shielding portion is held between the front surface portion of the lens main body and a rear surface portion thereof.

45. A soft contact lens which is fitted to a cornea, the soft contact lens comprising:

a light-shielding portion which shields incident light that is incident to the cornea; and

a lens main body made of a light permeable member that allows incident light to be transmitted, the lens main body having a diameter larger than that of the light-shielding portion and covering a front surface of the light-shielding portion and a back surface thereof,

wherein the light-shielding portion contains:

a main body of the light-shielding portion which is made of a light-shielding member;

an aperture having a diameter between 1.0 mm and 1.6 mm inclusive that allows the incident light to be transmitted, the aperture being positioned on a position of the main body of the light-shielding portion, the position including an optical axis extending to a center of the cornea and a center of a retina; and

a plurality of holes that maintains a scotopic vision and a night vision, the holes being provided around the aperture in the main body of the light-shielding portion and each of the holes having a diameter smaller than that of the aperture, and

5

wherein the diameter of the light-shielding portion is less than the diameter of lens main body, and the lens main body around the light-shielding portion functions as a light-transmission portion that maintains a peripheral vision by gathering the incident light to the cornea.

10

46. The soft contact lens according to claim 45 wherein the diameter of the light-shielding portion is not less than 4.0 mm and not more than 9.0 mm and the diameter of the lens main body is 14.0 mm or so.

47. The soft contact lens according to claim 45 wherein the lens main body contains a front surface portion and a rear surface portion, and the light-shielding portion is held between the front surface portion of the lens main body and a rear surface portion thereof.

15

20

* * * * *

UNITED STATES PATENT AND TRADEMARK OFFICE
CERTIFICATE OF CORRECTION

PATENT NO. : RE46,044 E
APPLICATION NO. : 14/133357
DATED : June 28, 2016
INVENTOR(S) : Hiroyuki Arai et al.

Page 1 of 1

It is certified that error appears in the above-identified patent and that said Letters Patent is hereby corrected as shown below:

IN THE SPECIFICATION

In Column 5, line 9, change “each of the holes 14 is h ,” to read --each of the holes 14 is Φ --.

In Column 5, line 24, change “optimal diameter h ” to read --optimal diameter Φ --.

In Column 8, Line 59, change “each of the holes is h ,” to read --each of the holes is Φ --.

Signed and Sealed this
Eleventh Day of October, 2016



Michelle K. Lee
Director of the United States Patent and Trademark Office