

US00RE46017E

(19) **United States**  
(12) **Reissued Patent**  
**Yang**

(10) **Patent Number:** **US RE46,017 E**  
(45) **Date of Reissued Patent:** **\*May 31, 2016**

(54) **SPLIT SERIAL-PARALLEL HYBRID  
DUAL-POWER DRIVE SYSTEM**

(71) Applicant: **Tai-Her Yang**, Dzan-Hwa (TW)

(72) Inventor: **Tai-Her Yang**, Dzan-Hwa (TW)

(\* ) Notice: This patent is subject to a terminal disclaimer.

(21) Appl. No.: **13/857,669**

(22) Filed: **Apr. 5, 2013**

**Related U.S. Patent Documents**

Reissue of:

(64) Patent No.: **7,918,760**  
Issued: **Apr. 5, 2011**  
Appl. No.: **11/950,538**  
Filed: **Dec. 5, 2007**

U.S. Applications:

(62) Division of application No. 10/975,525, filed on Oct. 29, 2004, now Pat. No. 7,377,876.

(51) **Int. Cl.**

**B60W 10/08** (2006.01)  
**B60K 6/387** (2007.10)  
**B60L 11/14** (2006.01)  
**B60K 6/48** (2007.10)  
**B60K 6/52** (2007.10)  
**B60W 10/06** (2006.01)  
**B60W 20/00** (2016.01)  
**B60W 10/26** (2006.01)  
**B60K 6/46** (2007.10)

(Continued)

(52) **U.S. Cl.**

CPC ..... **B60K 6/387** (2013.01); **B60K 6/442** (2013.01); **B60K 6/46** (2013.01); **B60K 6/48** (2013.01); **B60K 6/52** (2013.01); **B60L 11/14** (2013.01); **B60W 10/06** (2013.01); **B60W 10/08** (2013.01); **B60W 10/26** (2013.01); **B60W 20/00**

(2013.01); **B60K 2006/381** (2013.01); **Y02T 10/6217** (2013.01); **Y02T 10/6221** (2013.01); **Y02T 10/6234** (2013.01); **Y02T 10/6265** (2013.01); **Y02T 10/6286** (2013.01); **Y10S 903/907** (2013.01); **Y10T 74/19019** (2015.01); **Y10T 74/19126** (2015.01); **Y10T 477/23** (2015.01); **Y10T 477/26** (2015.01); **Y10T 477/27** (2015.01); **Y10T 477/60** (2015.01)

(58) **Field of Classification Search**

CPC ..... **B60K 6/387**; **B60K 6/48**; **B60K 6/52**; **B60K 6/442**; **B60K 6/46**; **B60K 2006/381**; **B60L 11/14**; **B60W 10/06**; **B60W 10/08**; **B60W 10/26**; **B60W 20/00**; **Y02T 10/6217**; **Y02T 10/6221**; **Y02T 10/6265**; **Y02T 10/6286**; **Y02T 10/6234**; **Y10S 903/907**; **Y10T 477/23**; **Y10T 477/60**; **Y10T 477/26**; **Y10T 477/27**; **Y10T 74/19019**; **Y10T 74/19126**

USPC ..... **477/3, 5**  
See application file for complete search history.

(56) **References Cited**

**U.S. PATENT DOCUMENTS**

5,301,764 A \* 4/1994 Gardner ..... 180/65.23  
5,346,031 A 9/1994 Gardner

(Continued)

*Primary Examiner* — William Doerrler

(74) *Attorney, Agent, or Firm* — Rabin & Berdo, P.C.

(57) **ABSTRACT**

A split serial-parallel hybrid dual-power drive system, comprised of two or more than two separation drive systems allowing independent operation to respectively drive the load, or all loads driven individually are incorporated in a common frame to drive land, surface, underwater transportation means or aircraft, industrial machines and equipment or any other load drive by rotational kinetic energy.

**14 Claims, 48 Drawing Sheets**

AMENDED

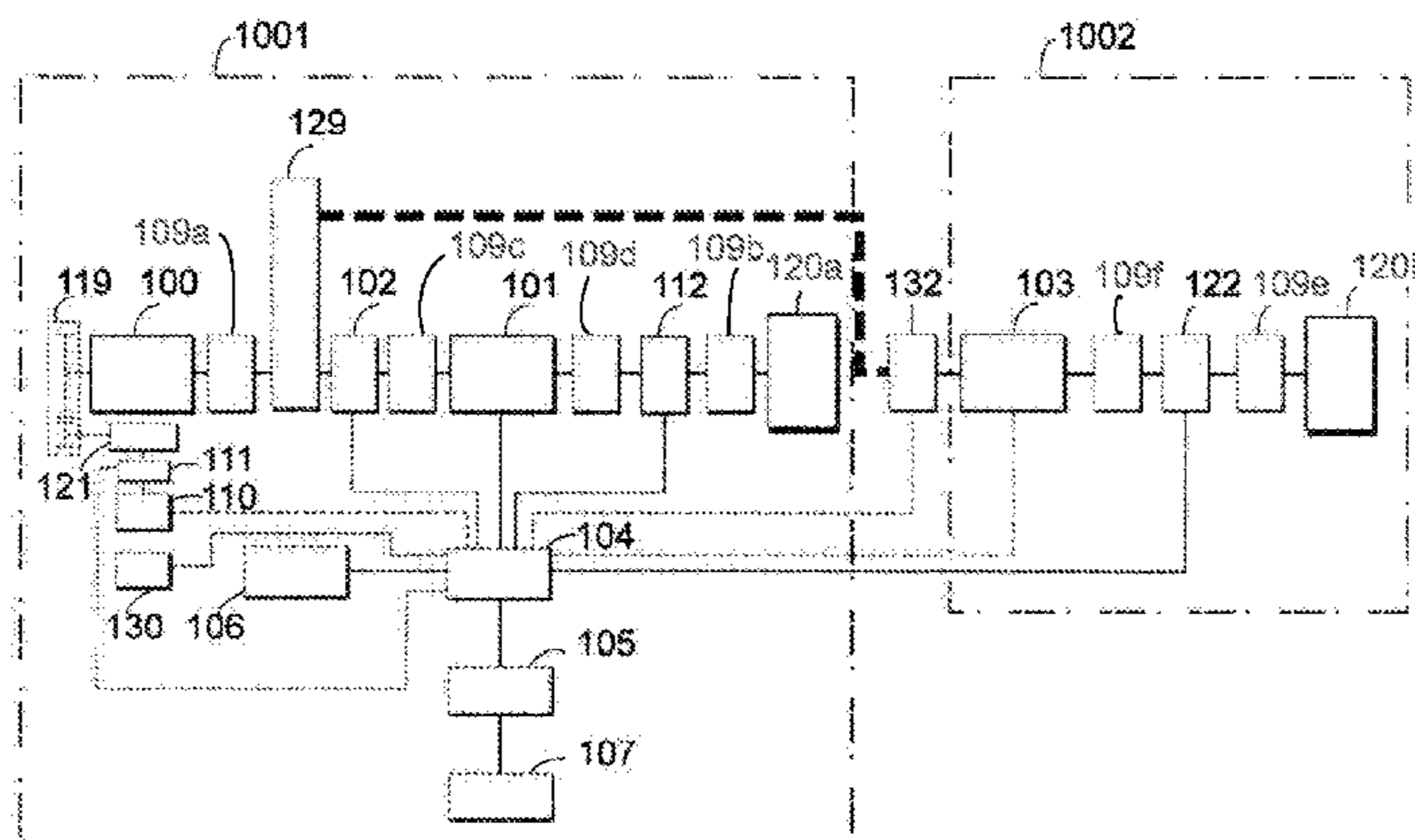

# US RE46,017 E

Page 2

(51)	<b>Int. Cl.</b>						
	<i>B60K 6/442</i>	(2007.10)		7,102,313 B2	9/2006	Kadota et al.	
	<i>B60K 6/38</i>	(2007.10)		7,117,963 B2 *	10/2006	Saito et al. ....	180/65.1
				7,140,461 B2	11/2006	Morrow	
				7,173,344 B2 *	2/2007	Yang .....	290/4 R
				7,174,979 B2	2/2007	Ohta et al.	
				7,240,748 B2	7/2007	Kira et al.	
				7,255,186 B2	8/2007	Wakuta et al.	
				7,264,071 B2	9/2007	Schmidt et al.	
				7,377,876 B2 *	5/2008	Yang .....	477/3
				7,497,285 B1 *	3/2009	Radev .....	180/65.225
				7,546,186 B2 *	6/2009	Yang .....	701/22
				7,561,949 B2 *	7/2009	Yang .....	701/22
				7,588,513 B2 *	9/2009	Yang .....	477/3
				7,600,448 B2 *	10/2009	Yang .....	74/664
				7,607,371 B2 *	10/2009	Yang .....	74/665 L
				7,625,310 B2 *	12/2009	Yang .....	477/3
				7,654,933 B2 *	2/2010	Yang .....	477/5
				7,662,062 B2 *	2/2010	Yang .....	477/5
				7,669,683 B2 *	3/2010	Yang .....	180/242
				7,670,255 B2 *	3/2010	Yang .....	477/5
				7,695,402 B2 *	4/2010	Yang .....	477/5
				7,695,403 B2 *	4/2010	Yang .....	477/5
				7,918,759 B2 *	4/2011	Yang .....	477/5
				7,918,760 B2 *	4/2011	Yang .....	477/5
				7,918,761 B2 *	4/2011	Yang .....	477/5
				8,056,659 B2 *	11/2011	Oba et al. ....	180/65.225
				8,122,983 B2 *	2/2012	Katsuta et al. ....	180/65.225
				8,231,491 B2 *	7/2012	Oba et al. ....	475/5
				8,307,924 B2 *	11/2012	Wang et al. ....	180/65.23
				8,540,601 B2 *	9/2013	Wang et al. ....	477/5
				2005/0161268 A1 *	7/2005	Yang .....	180/65.2
				2006/0016630 A1 *	1/2006	Yang .....	180/65.1

(56)	<b>References Cited</b>						
	<b>U.S. PATENT DOCUMENTS</b>						
	5,562,566 A	10/1996	Yang				
	6,041,877 A	3/2000	Yamada et al.				
	6,048,288 A	4/2000	Tsujii et al.				
	6,053,842 A *	4/2000	Kitada et al. ....	477/5			
	6,251,037 B1	6/2001	Baumgaertner et al.				
	RE37,743 E *	6/2002	Yang .....	477/3			
	6,478,705 B1	11/2002	Holmes et al.				
	6,492,742 B1	12/2002	Fujikawa et al.				
	6,524,217 B1	2/2003	Murakami et al.				
	6,549,840 B1	4/2003	Mikami et al.				
	6,551,208 B1	4/2003	Holmes et al.				
	6,566,826 B2 *	5/2003	Imai et al. ....	318/11			
	6,638,195 B2	10/2003	Williams				
	6,722,332 B2	4/2004	Kojima				
	6,770,005 B2	8/2004	Aikawa et al.				
	6,857,985 B2	2/2005	Williams				
	6,942,054 B2	9/2005	Kim				
	6,962,550 B2	11/2005	Kadota				
	6,964,311 B2 *	11/2005	Yang .....	180/65.1			
	6,964,627 B2	11/2005	Ai et al.				
	6,971,461 B2 *	12/2005	Yamamoto et al. ....	180/65.25			
	7,004,018 B2 *	2/2006	Kadota et al. ....	73/115.02			
	7,028,796 B2	4/2006	Kim				
	RE39,085 E	5/2006	Yang				
	7,040,433 B2	5/2006	Yamamoto et al.				

\* cited by examiner

AMENDED

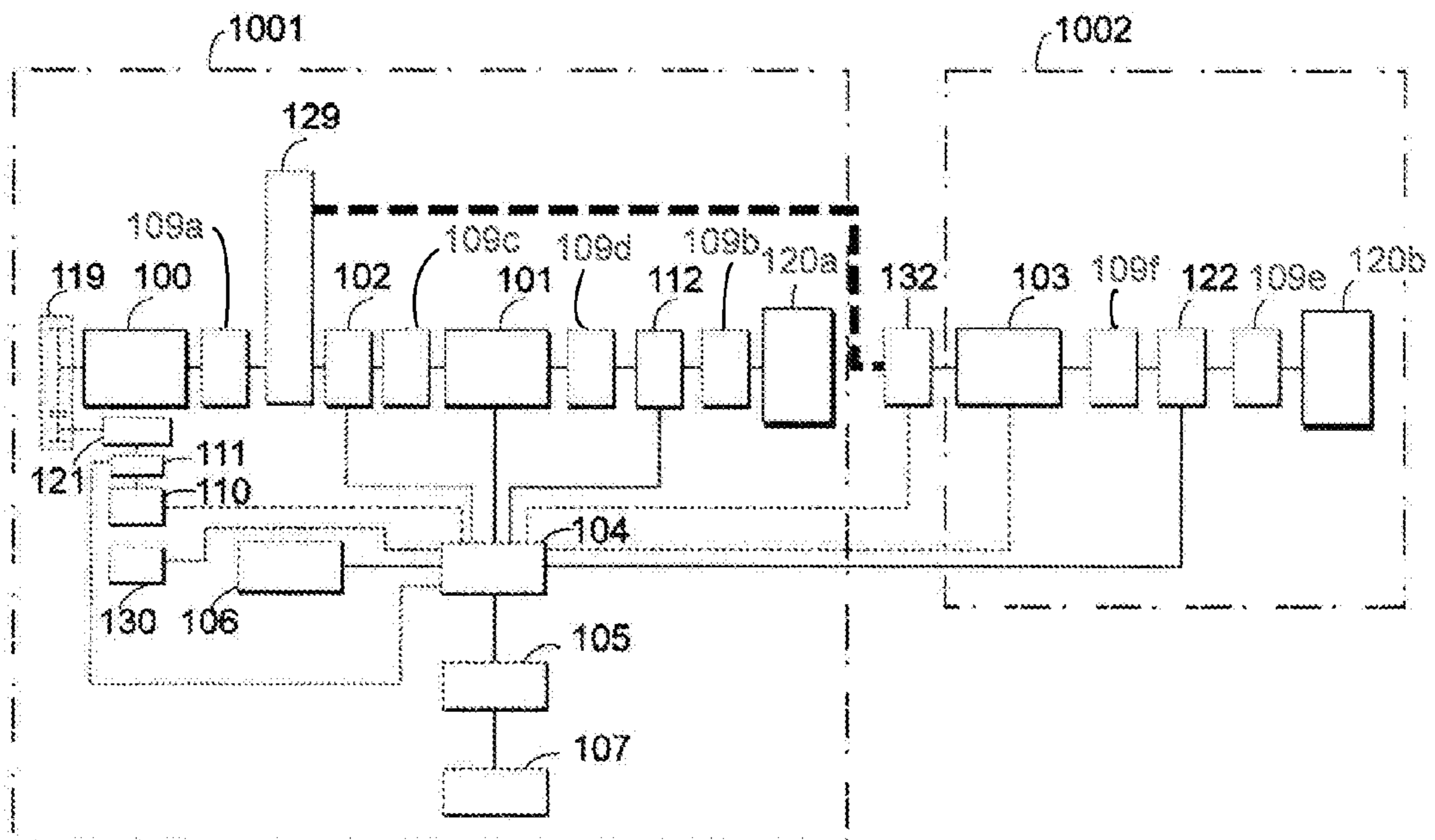

FIG. 1

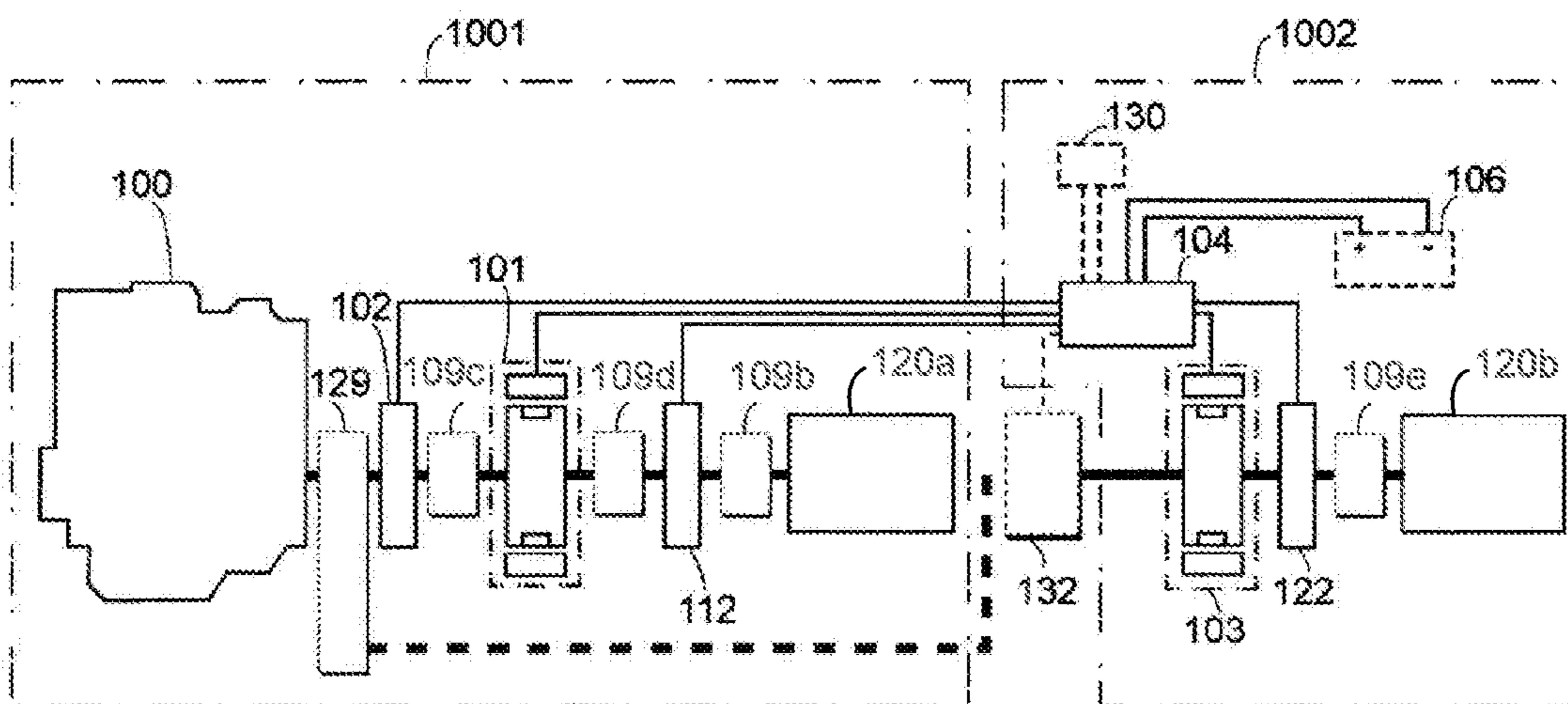

FIG. 2

AMENDED

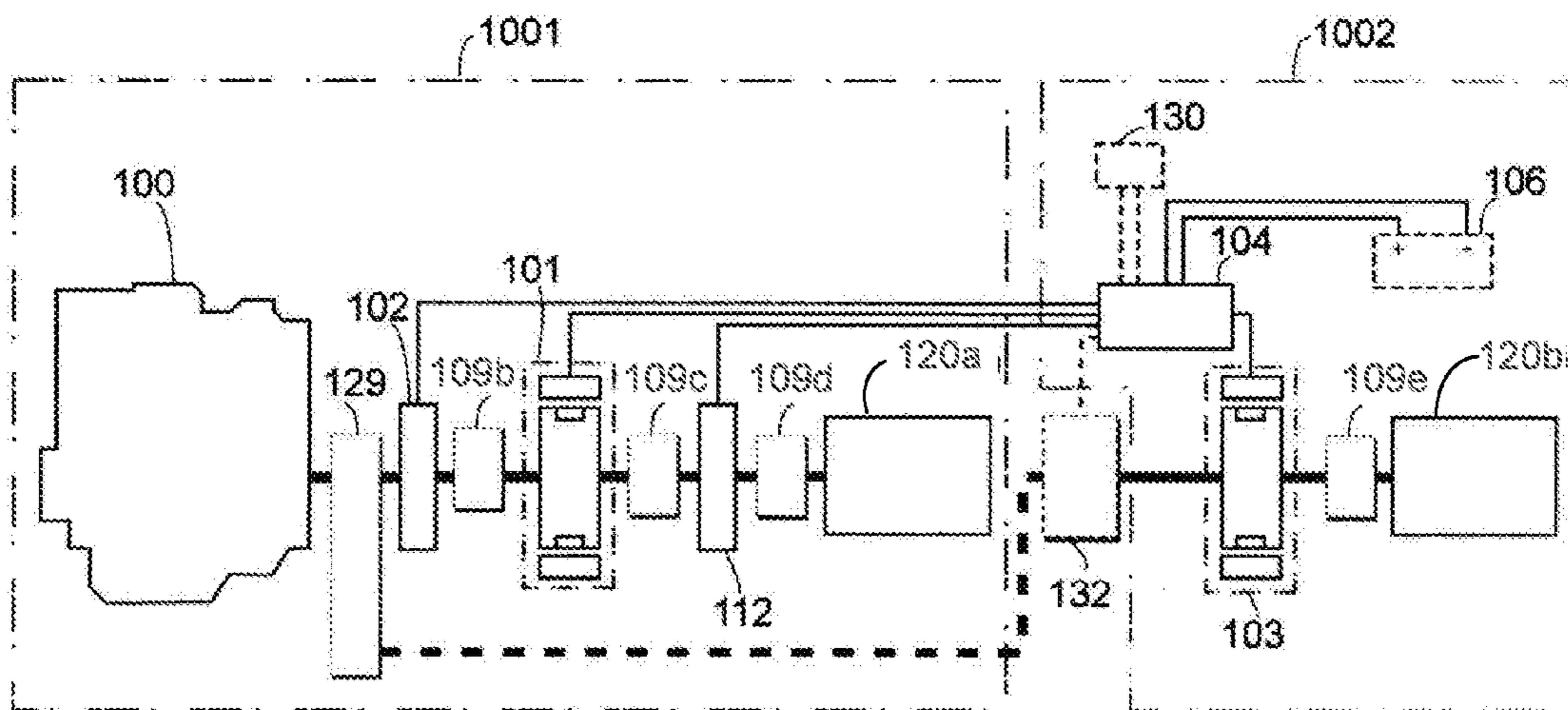

FIG. 3

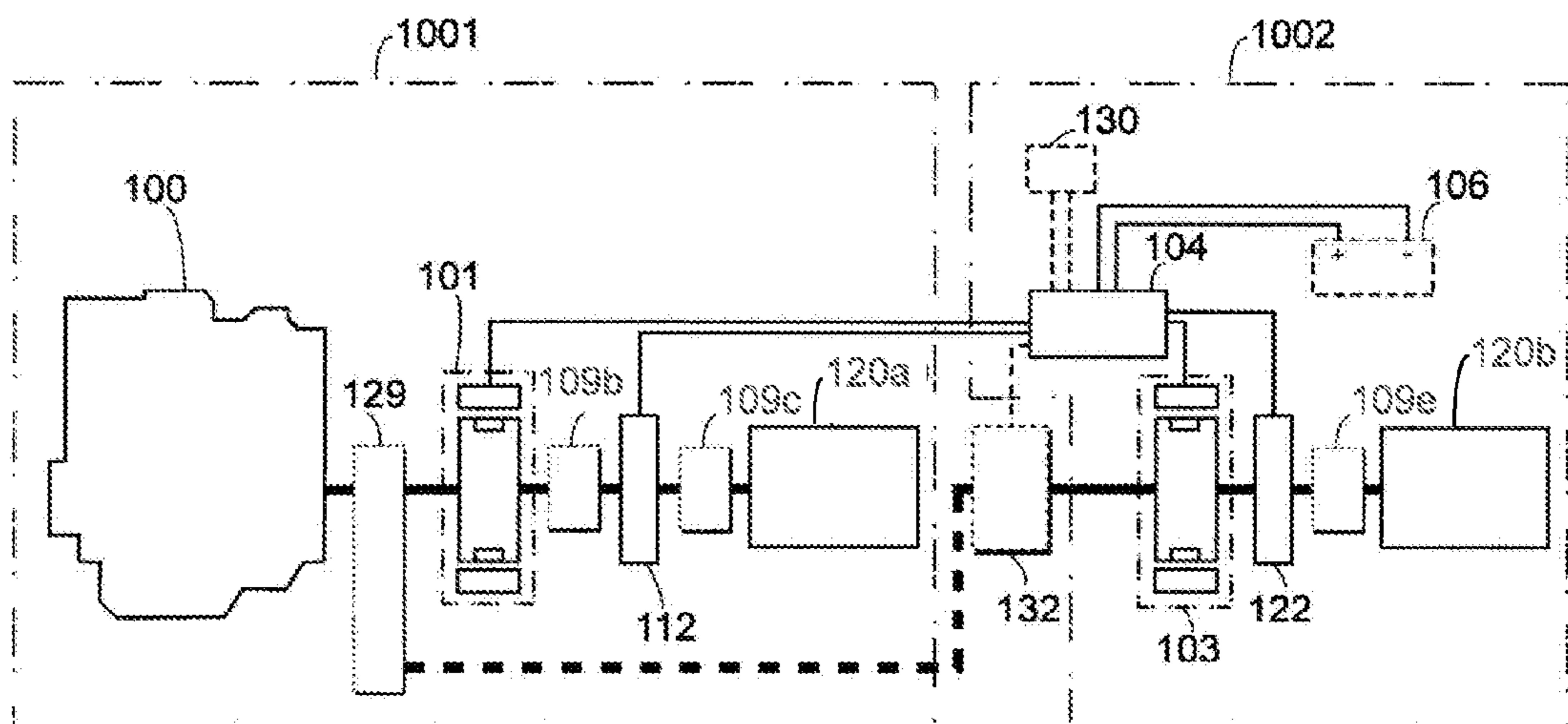

FIG. 4

AMENDED

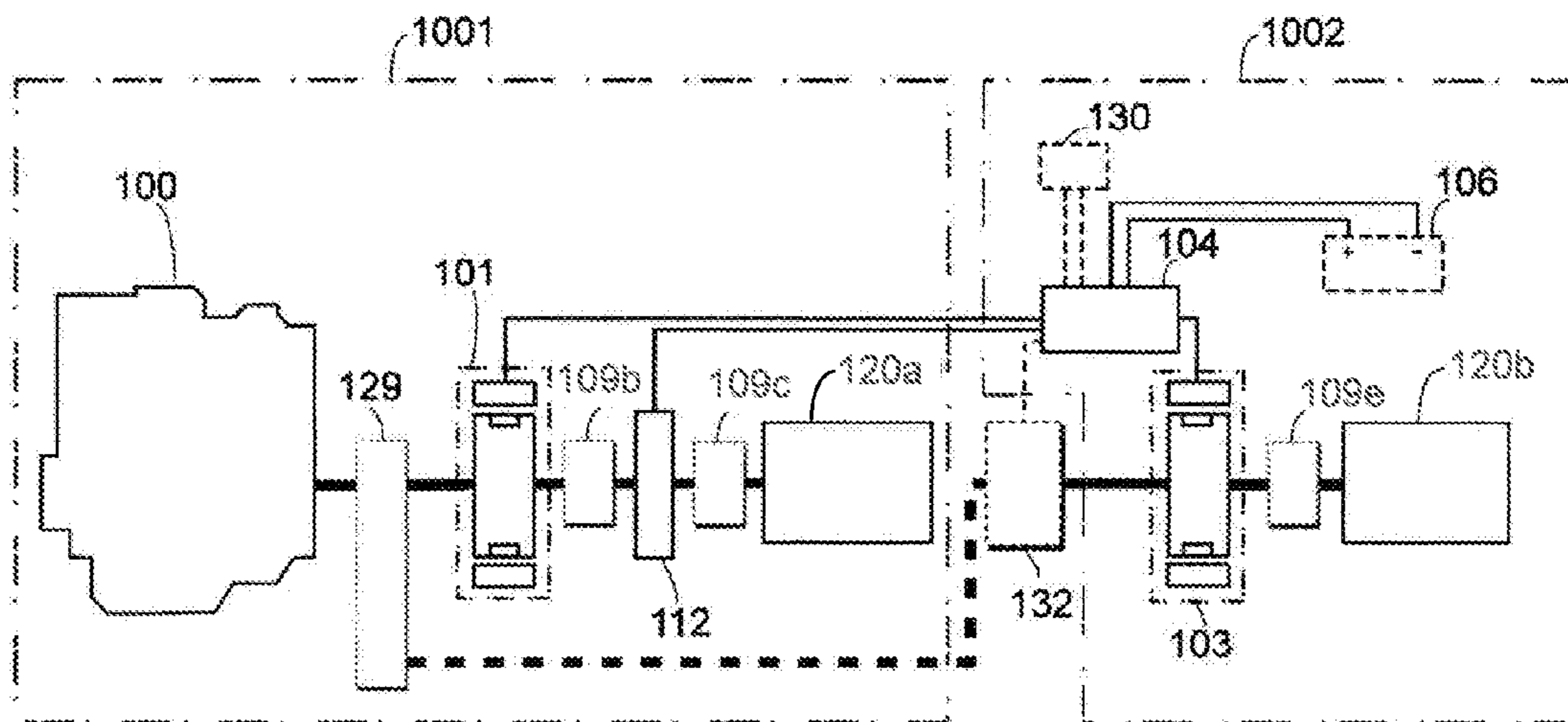

FIG. 5

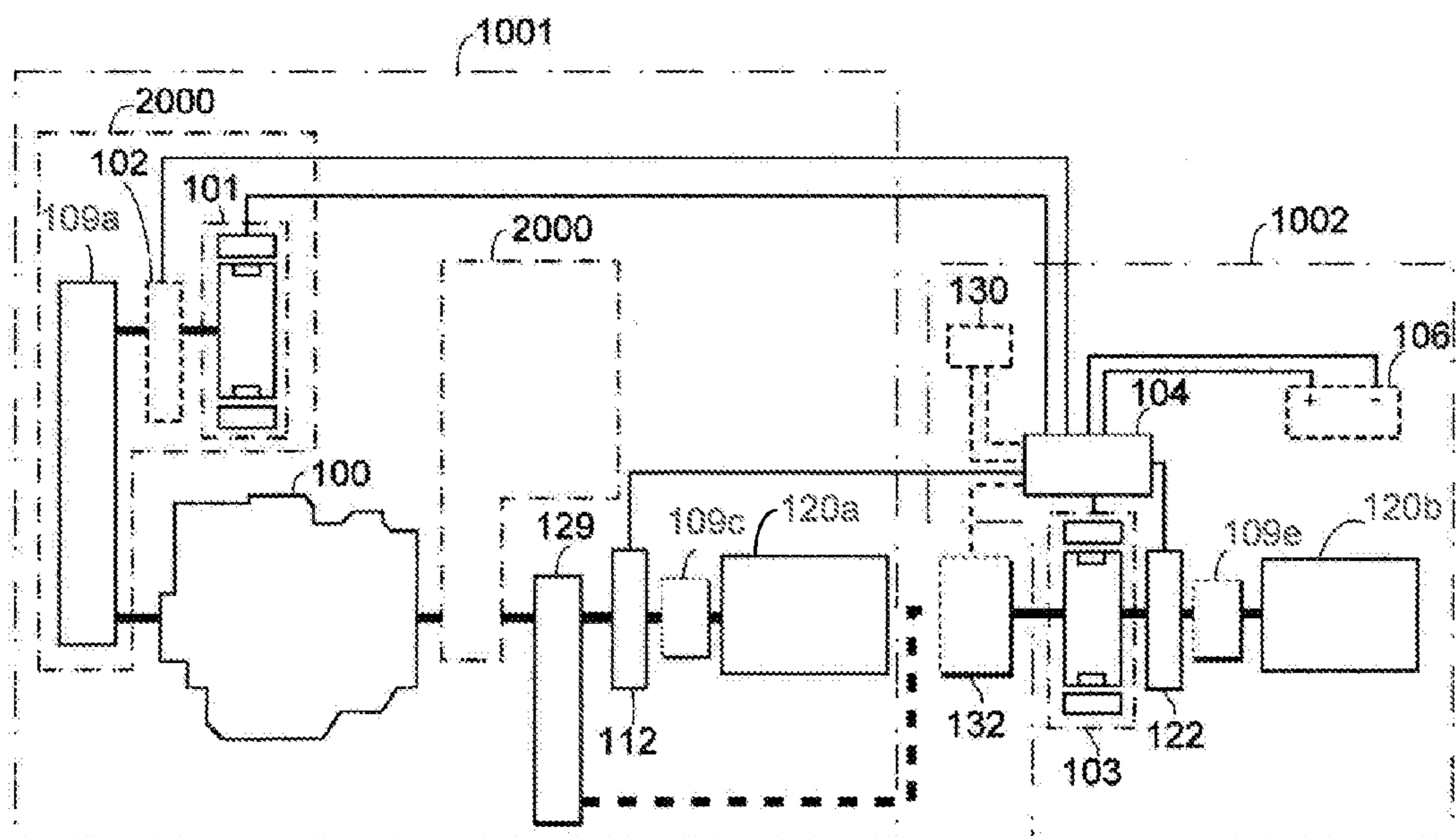

FIG. 6

AMENDED

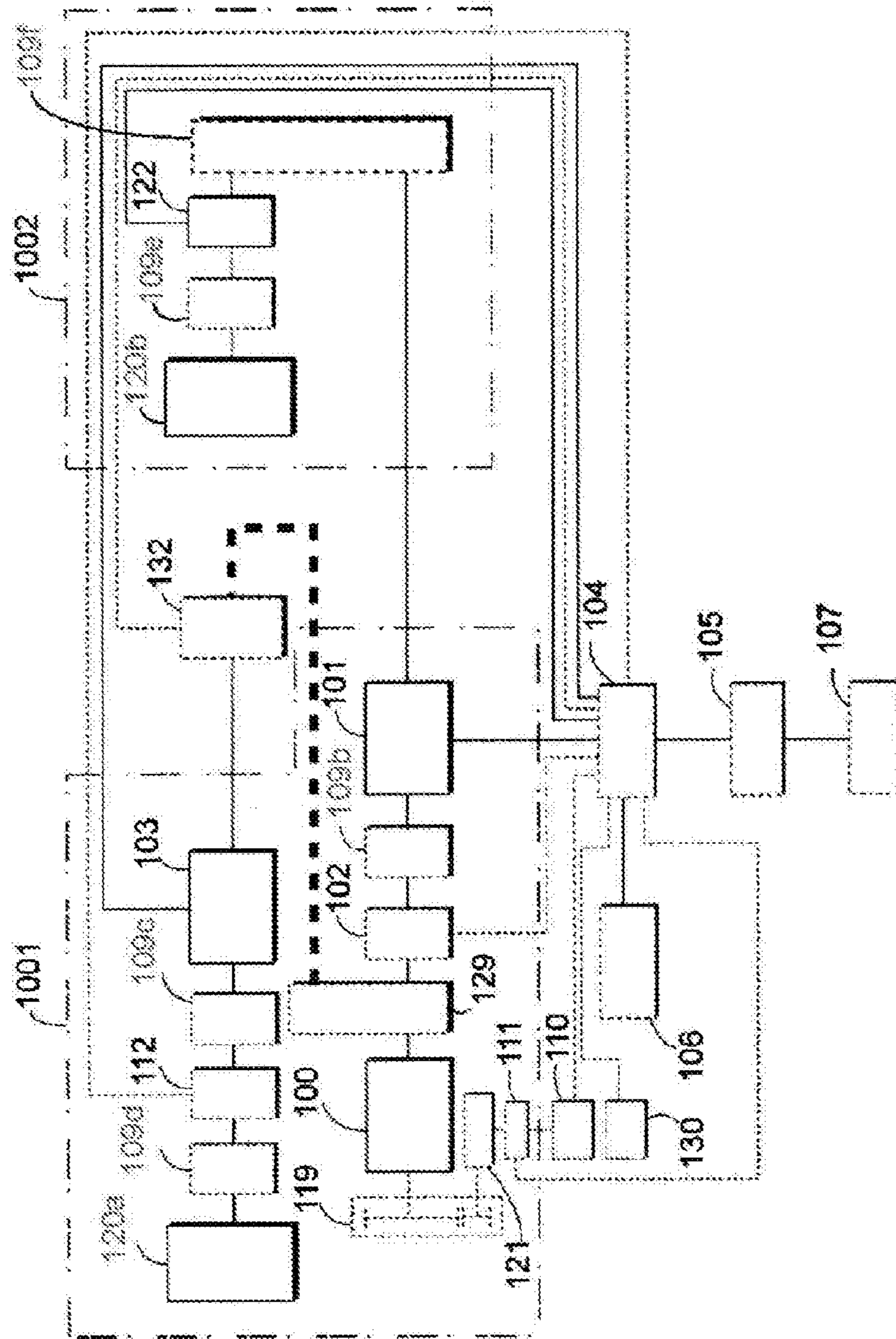

FIG. 7

AMENDED

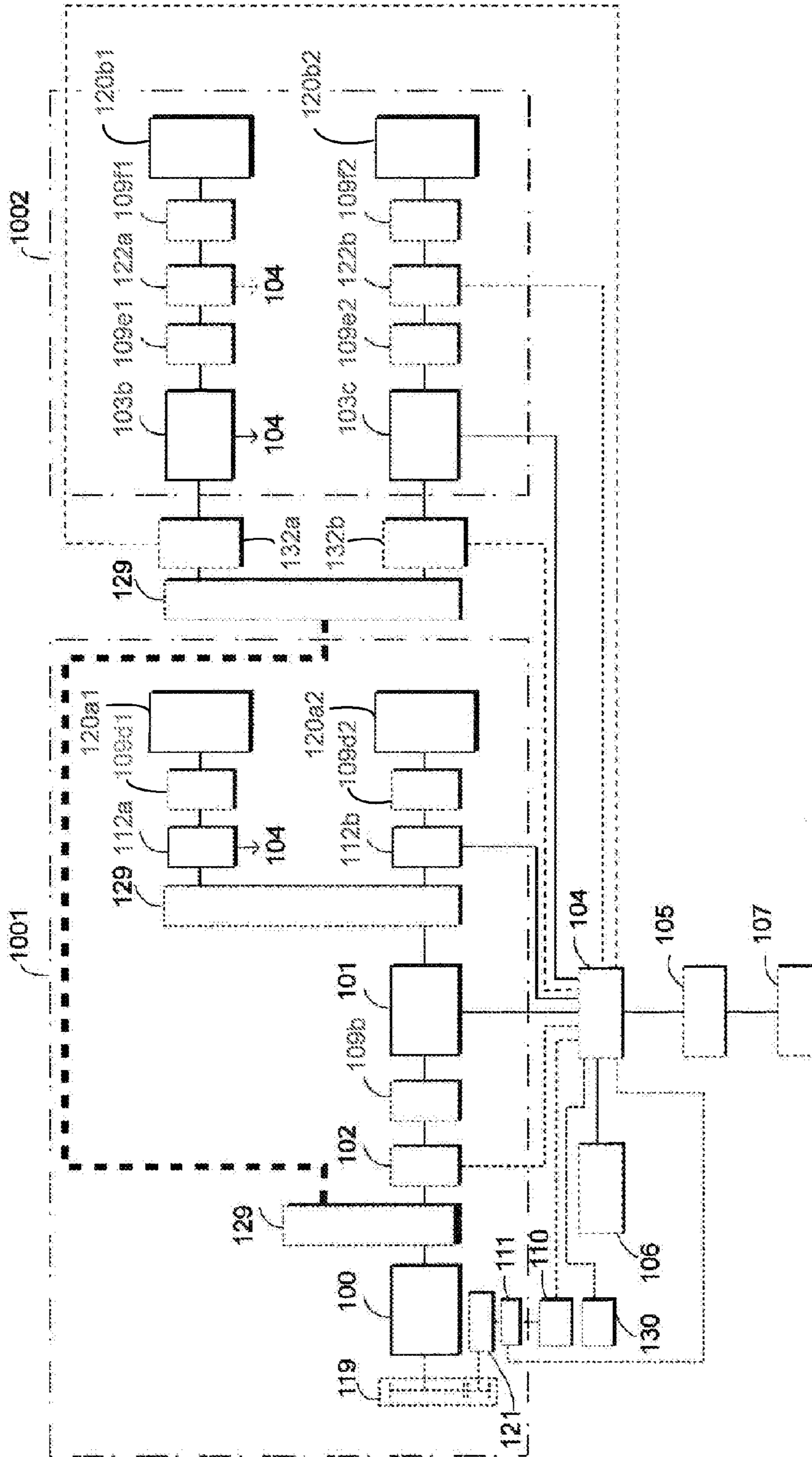

FIG. 8

AMENDED

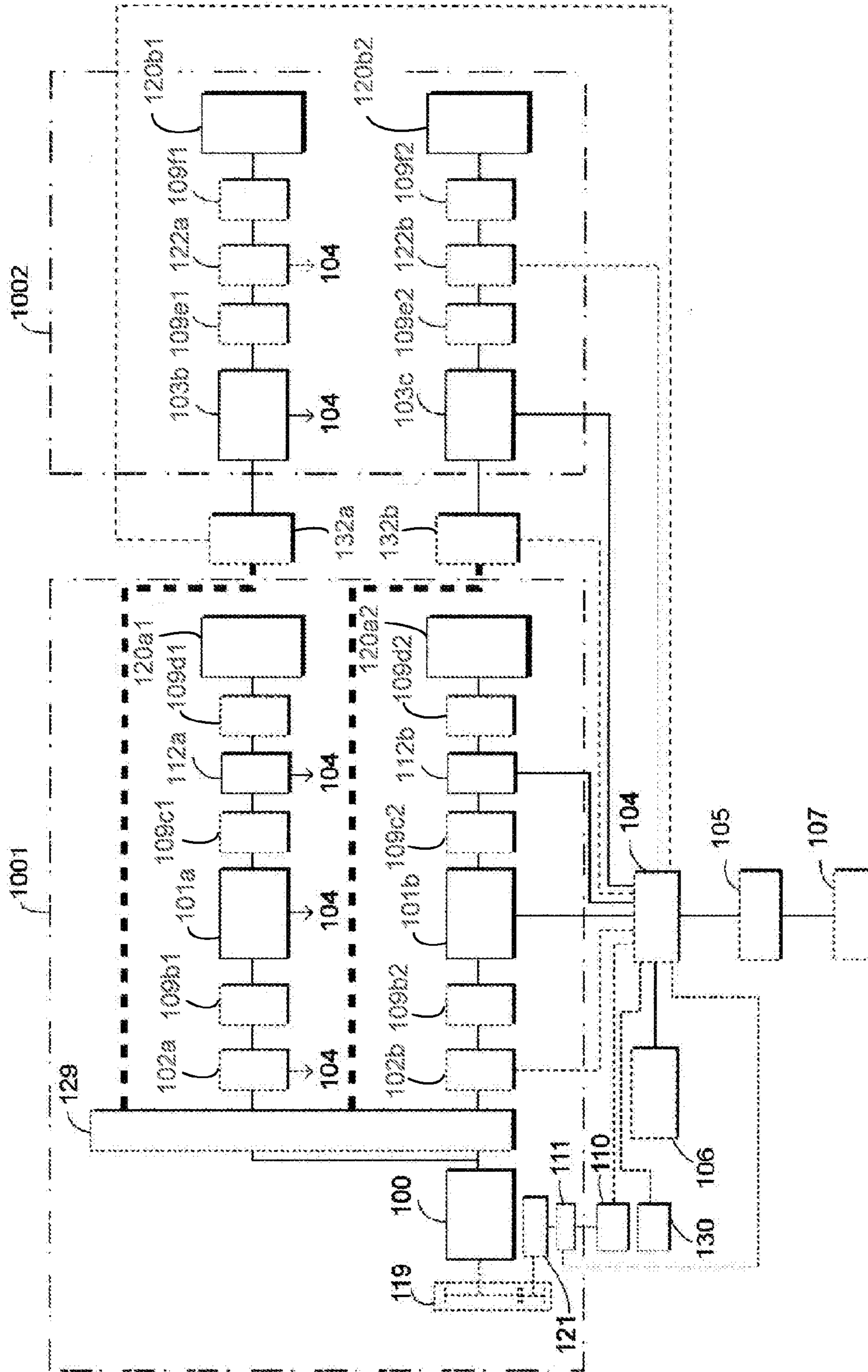

FIG. 9



AMENDED

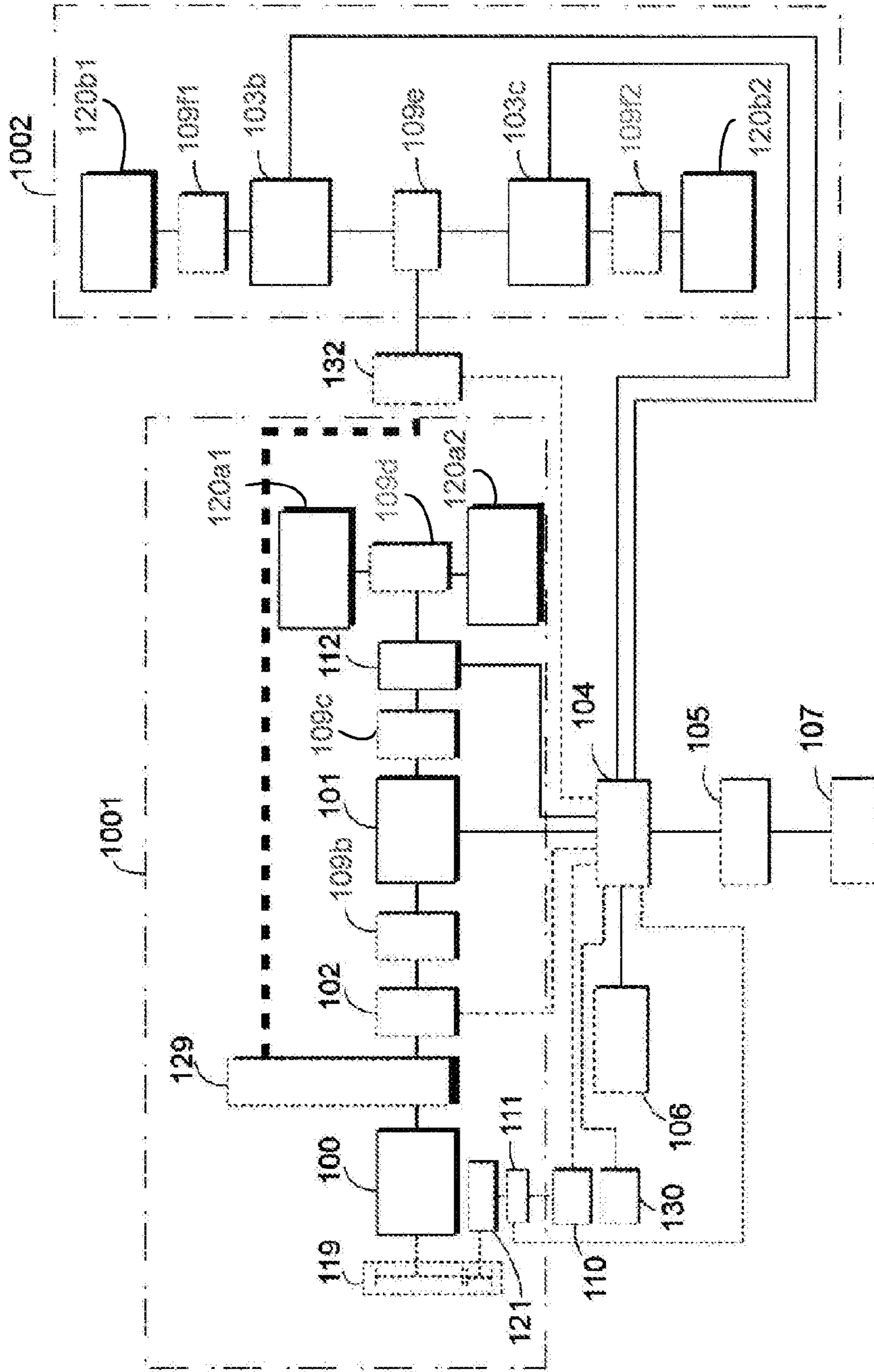

FIG. 10

AMENDED

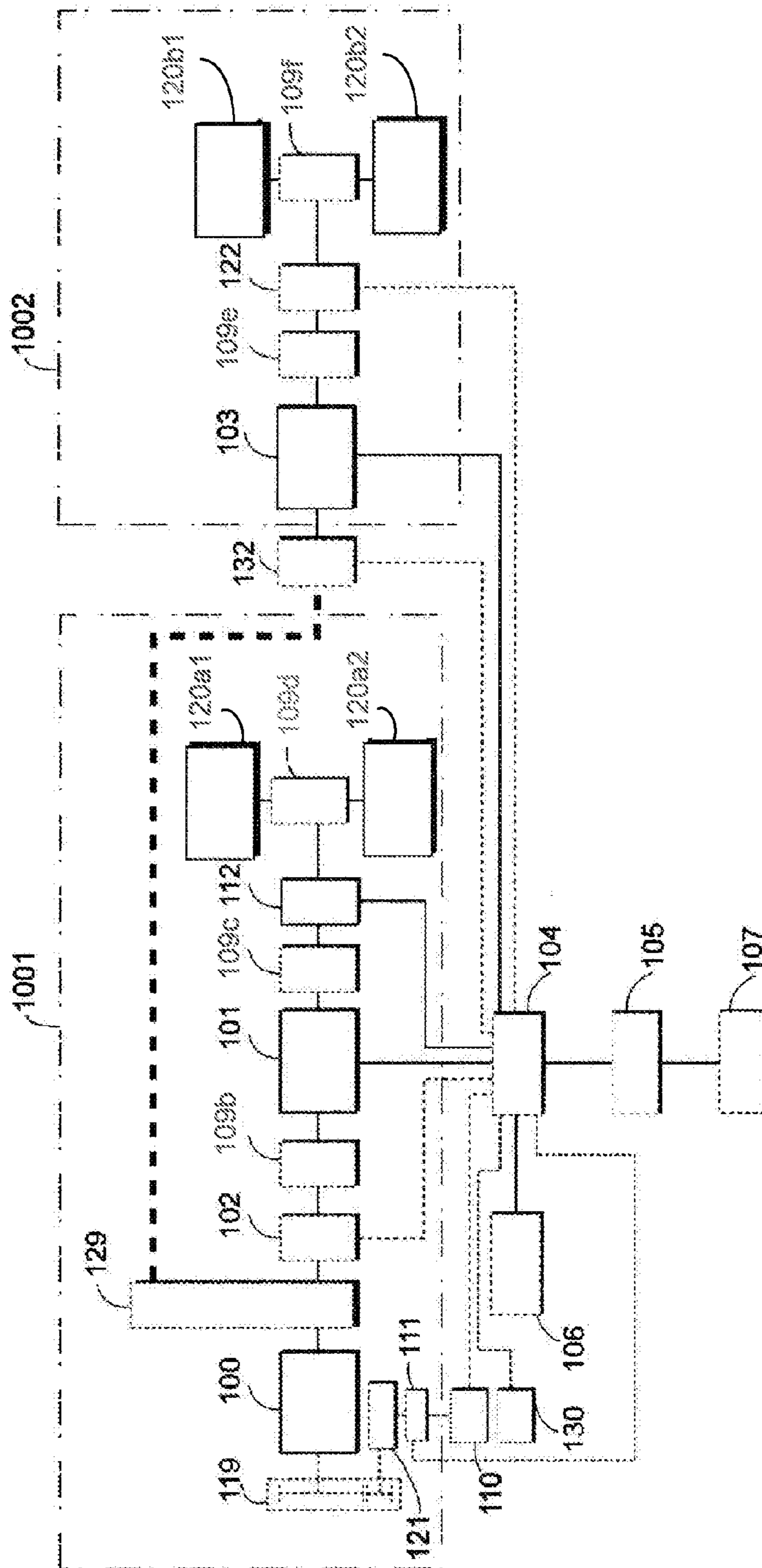

FIG. 11

AMENDED

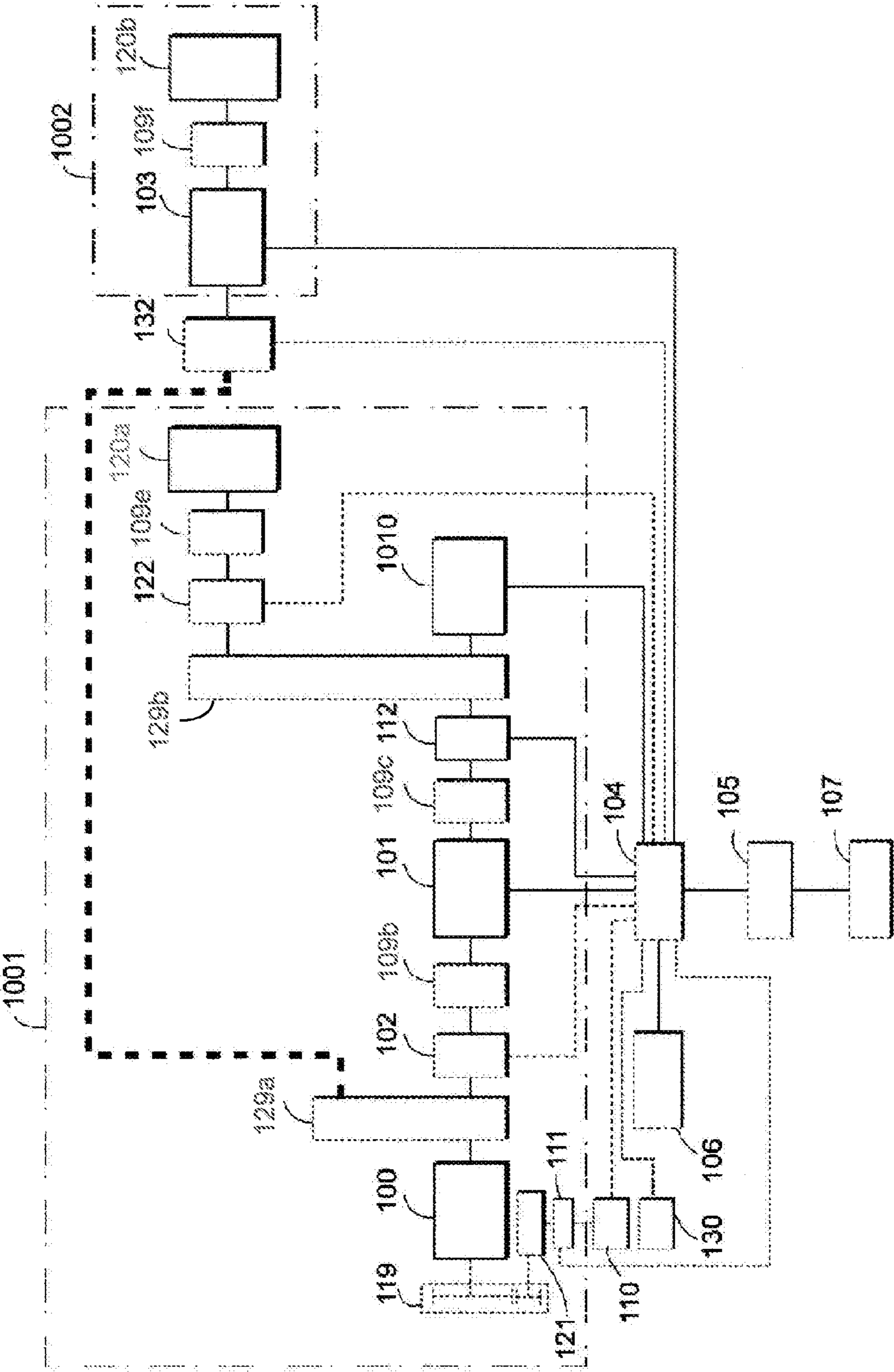

FIG. 12

AMENDED

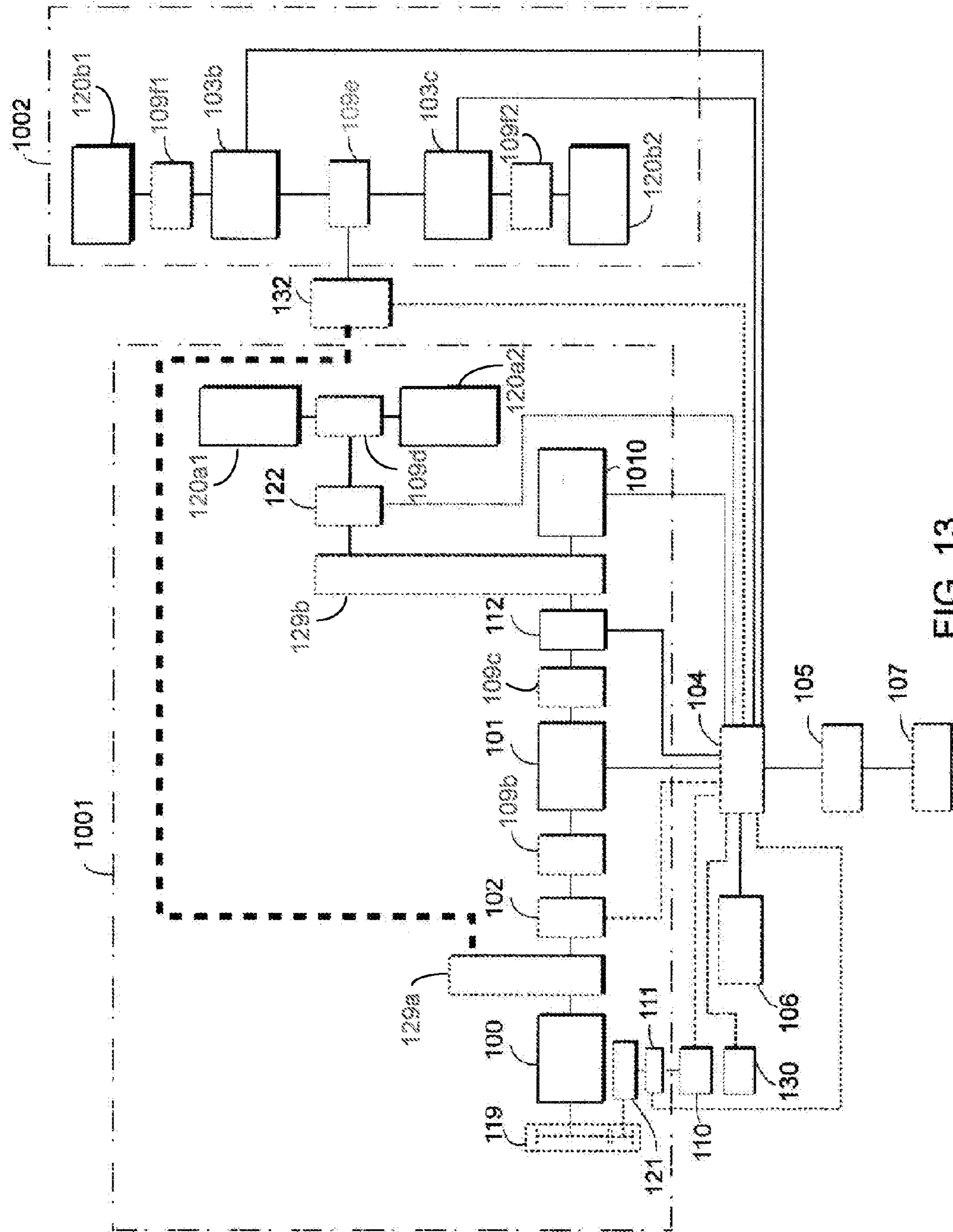

FIG. 13

AMENDED

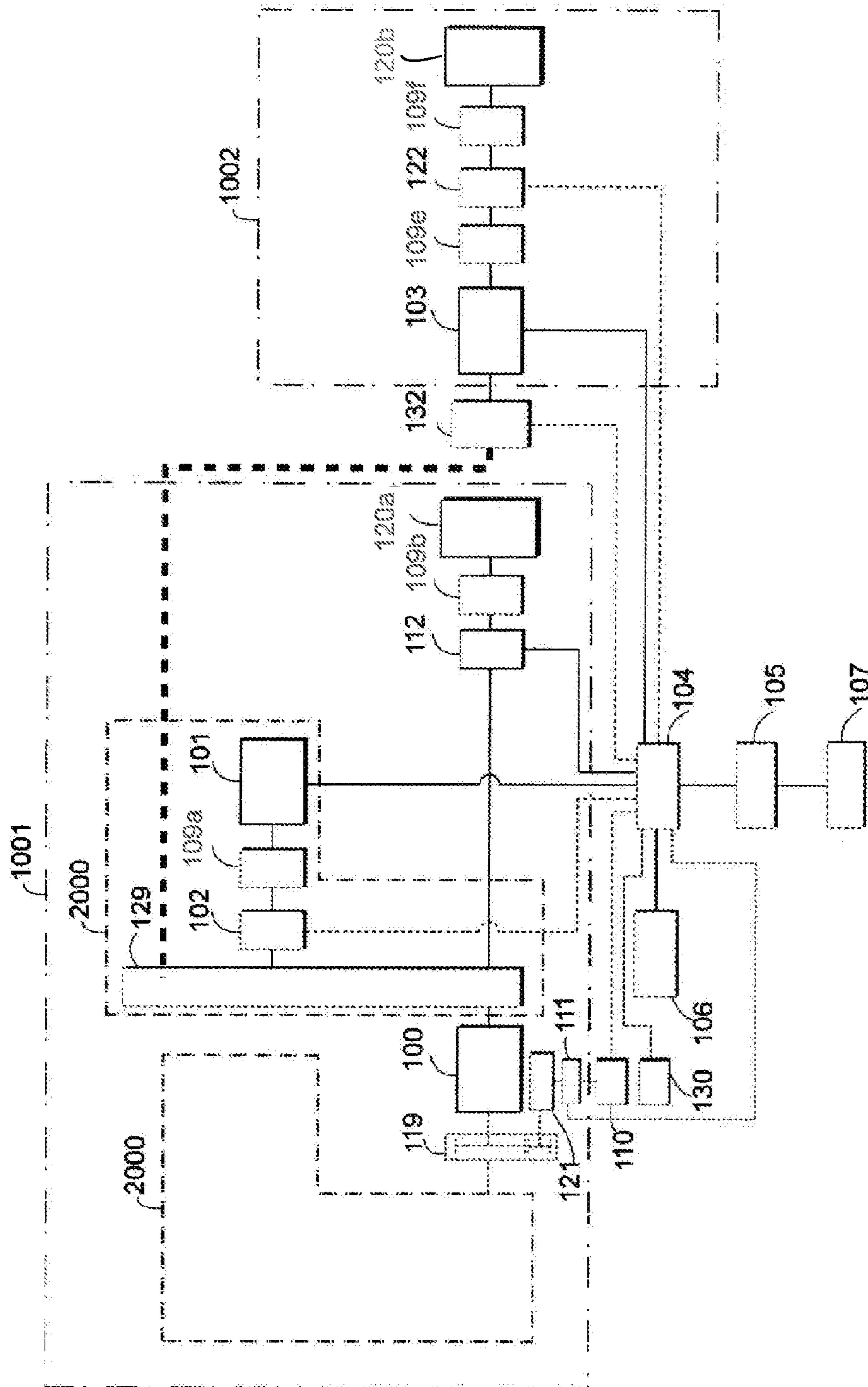

FIG. 14

AMENDED

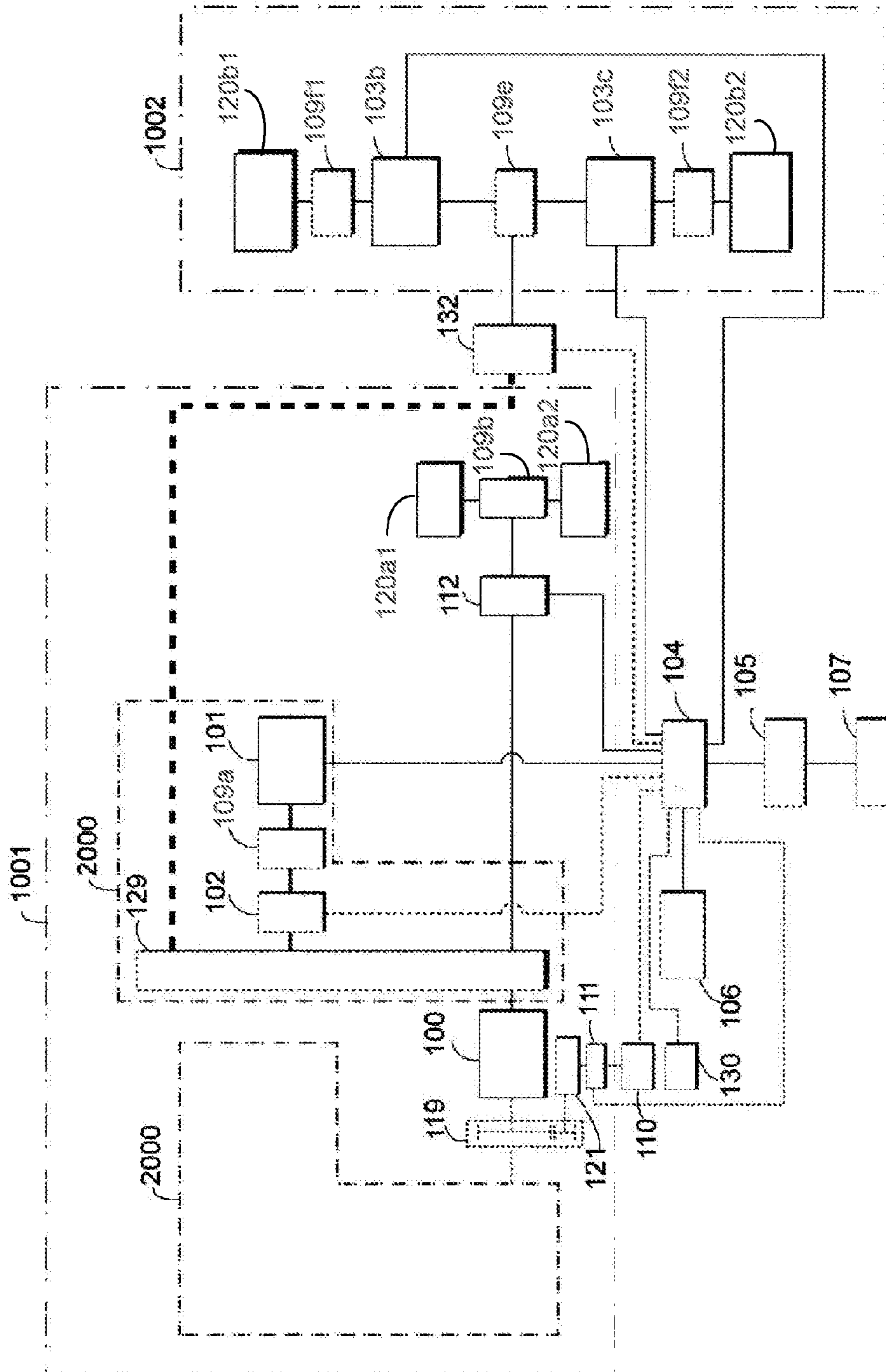

FIG. 15

AMENDED

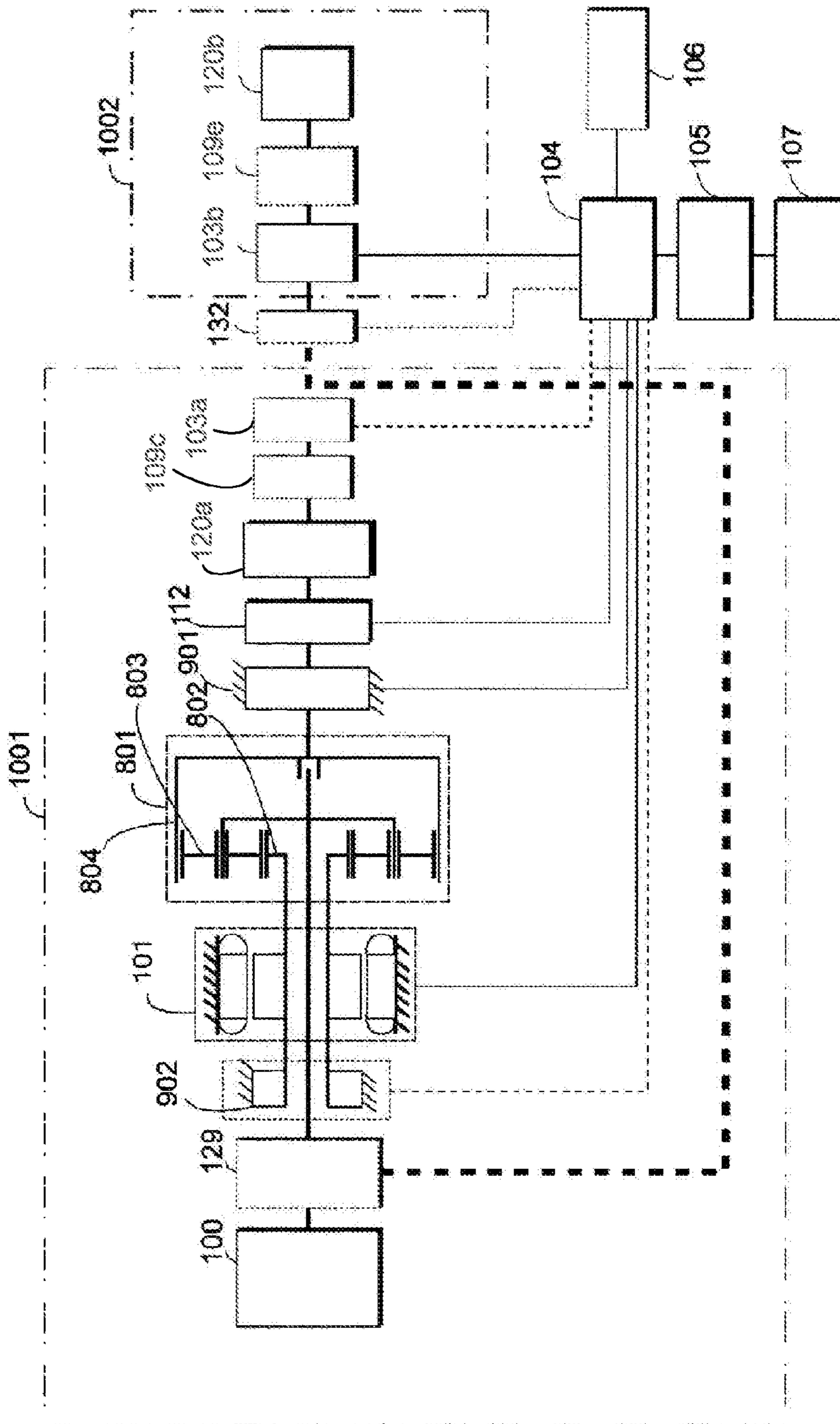

FIG. 16

AMENDED

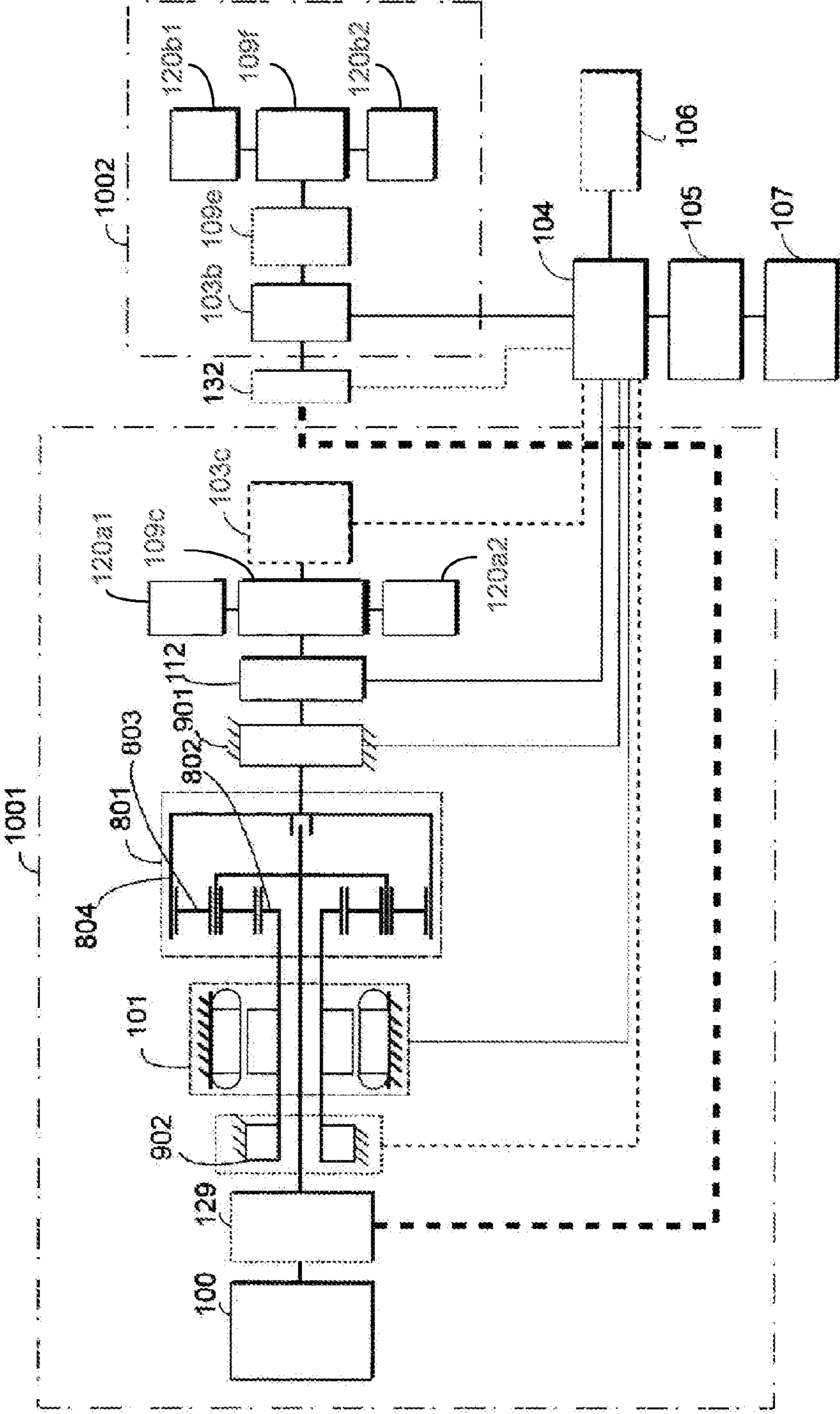

FIG. 17



AMENDED

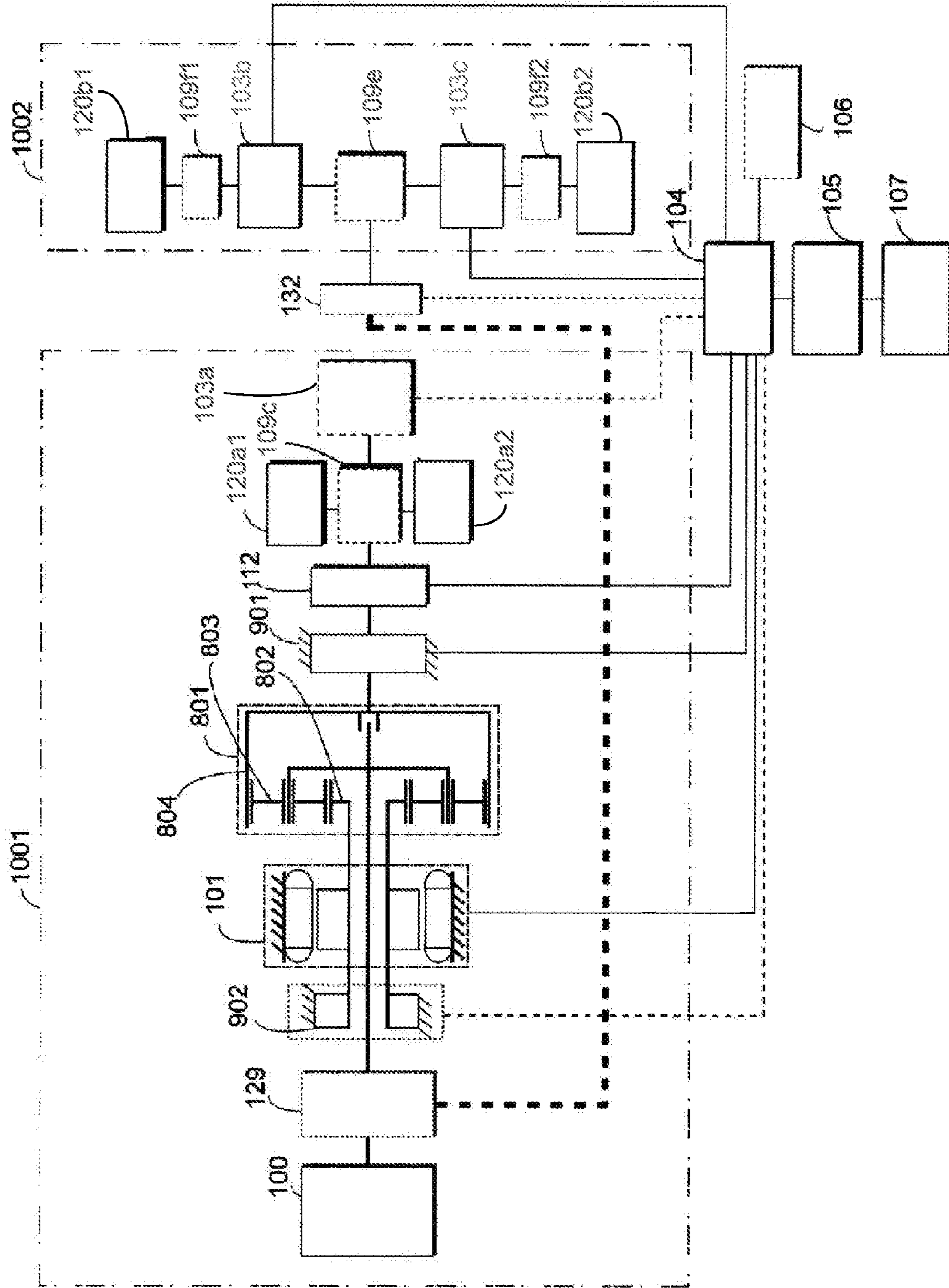

FIG. 18

AMENDED

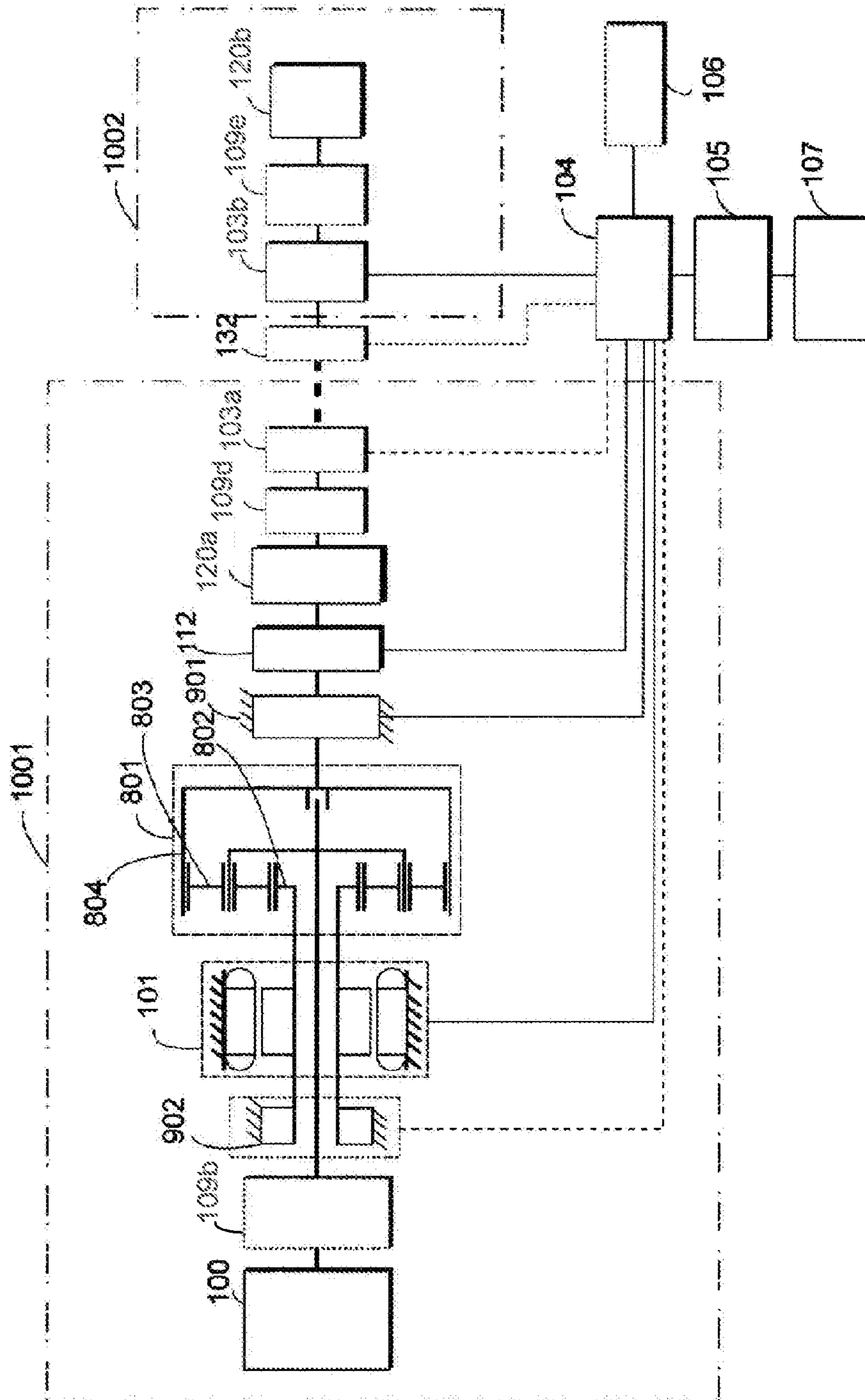

FIG. 19

AMENDED

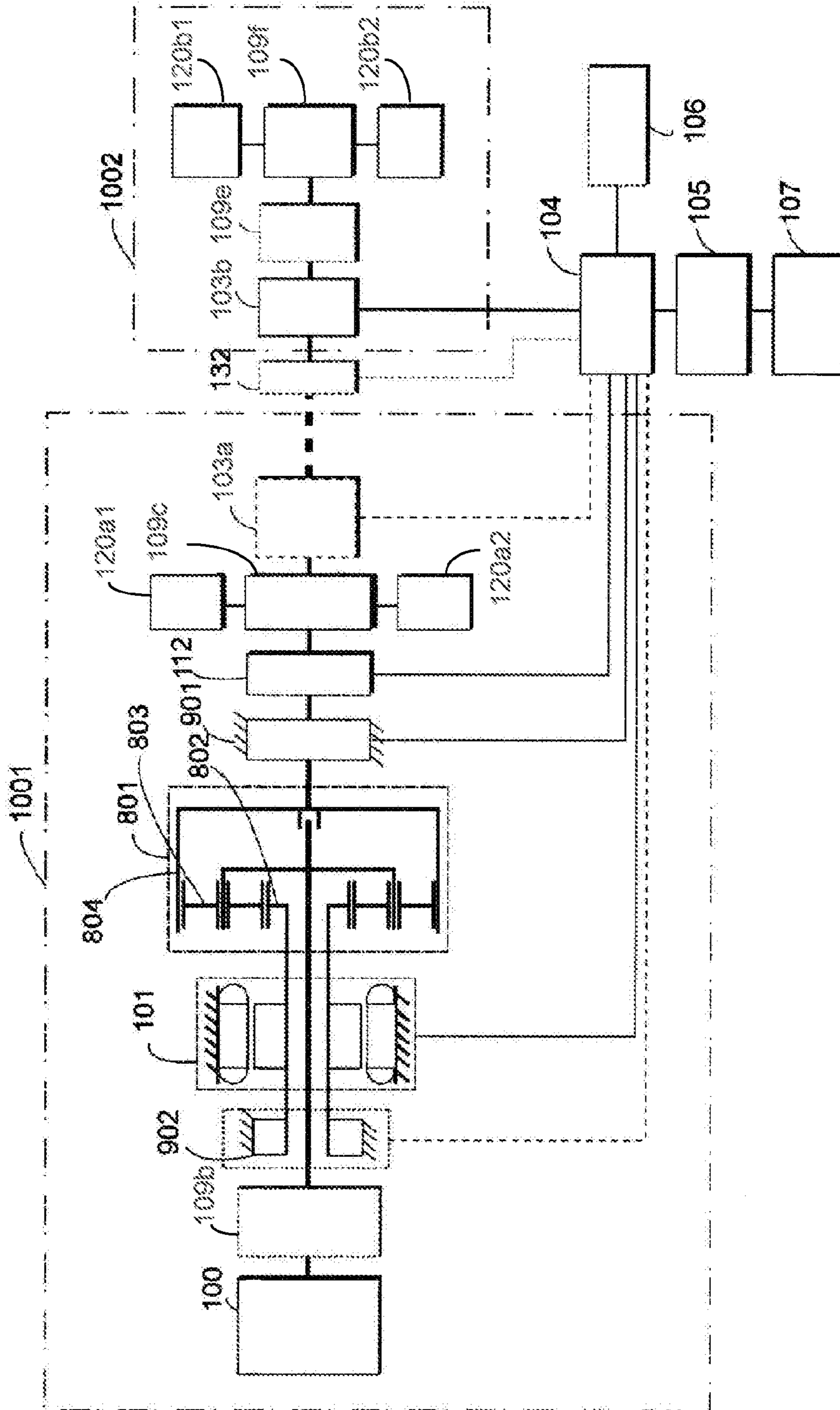

FIG. 20

AMENDED

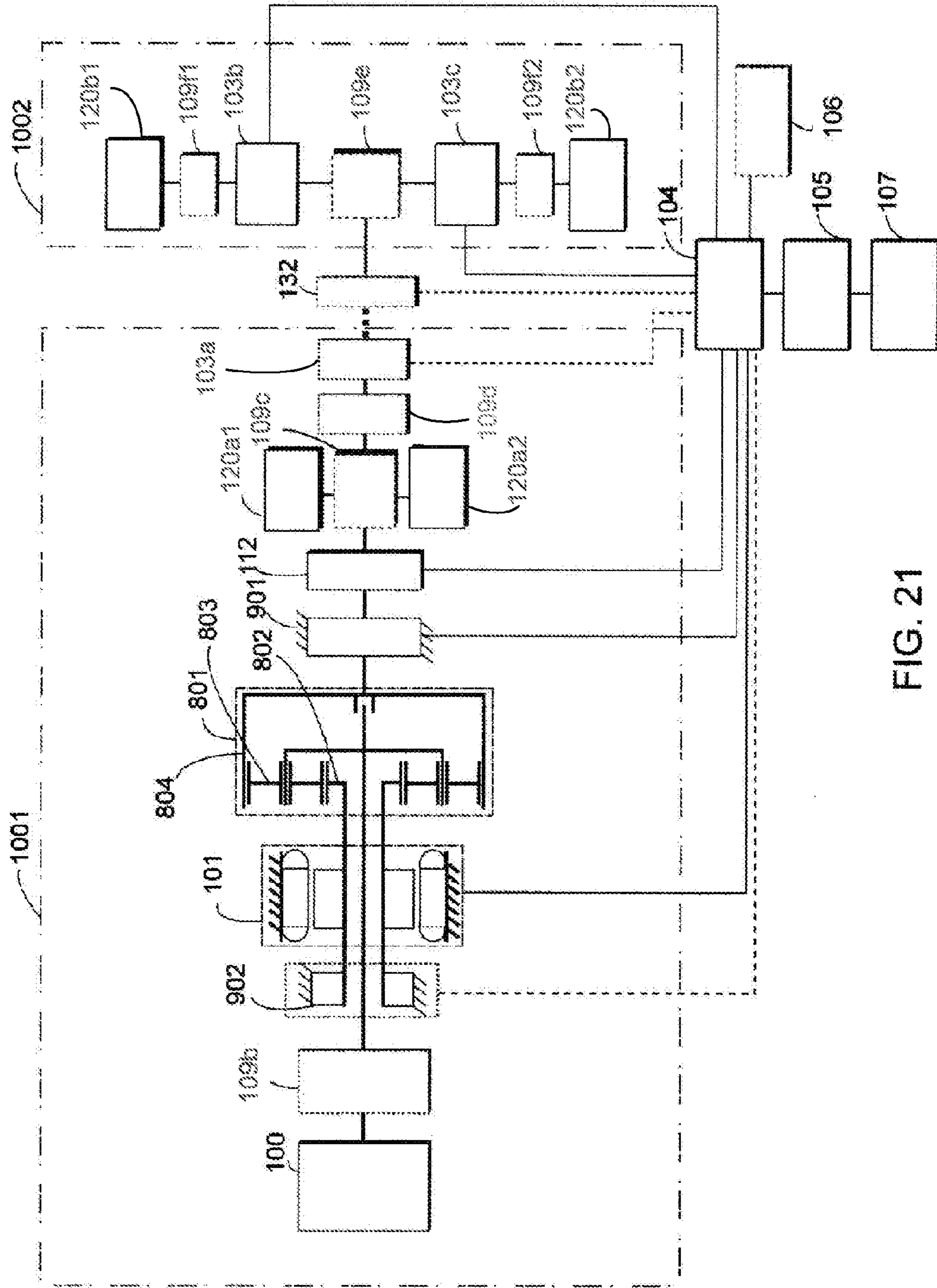

FIG. 21



AMENDED

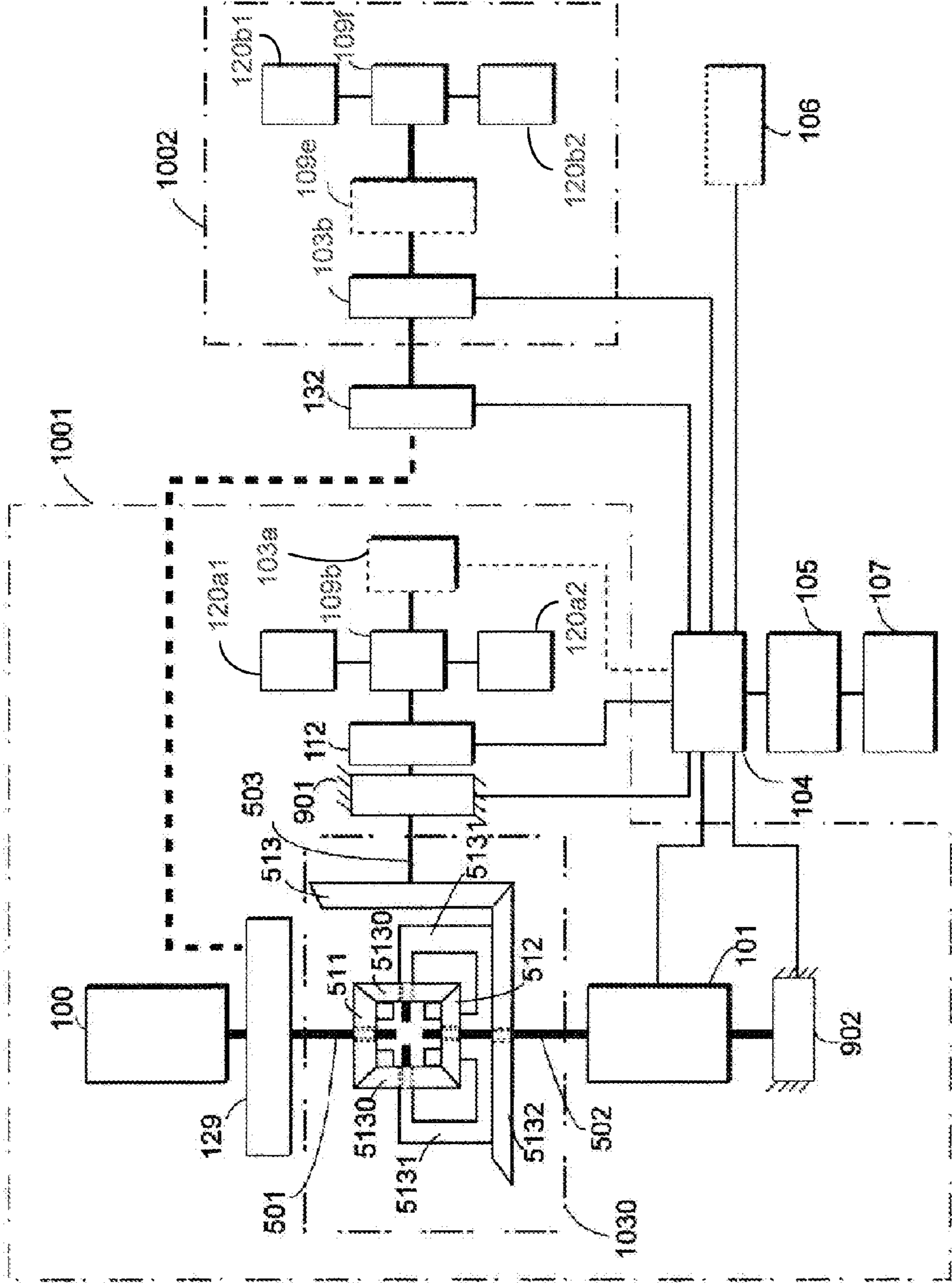

FIG. 23

AMENDED

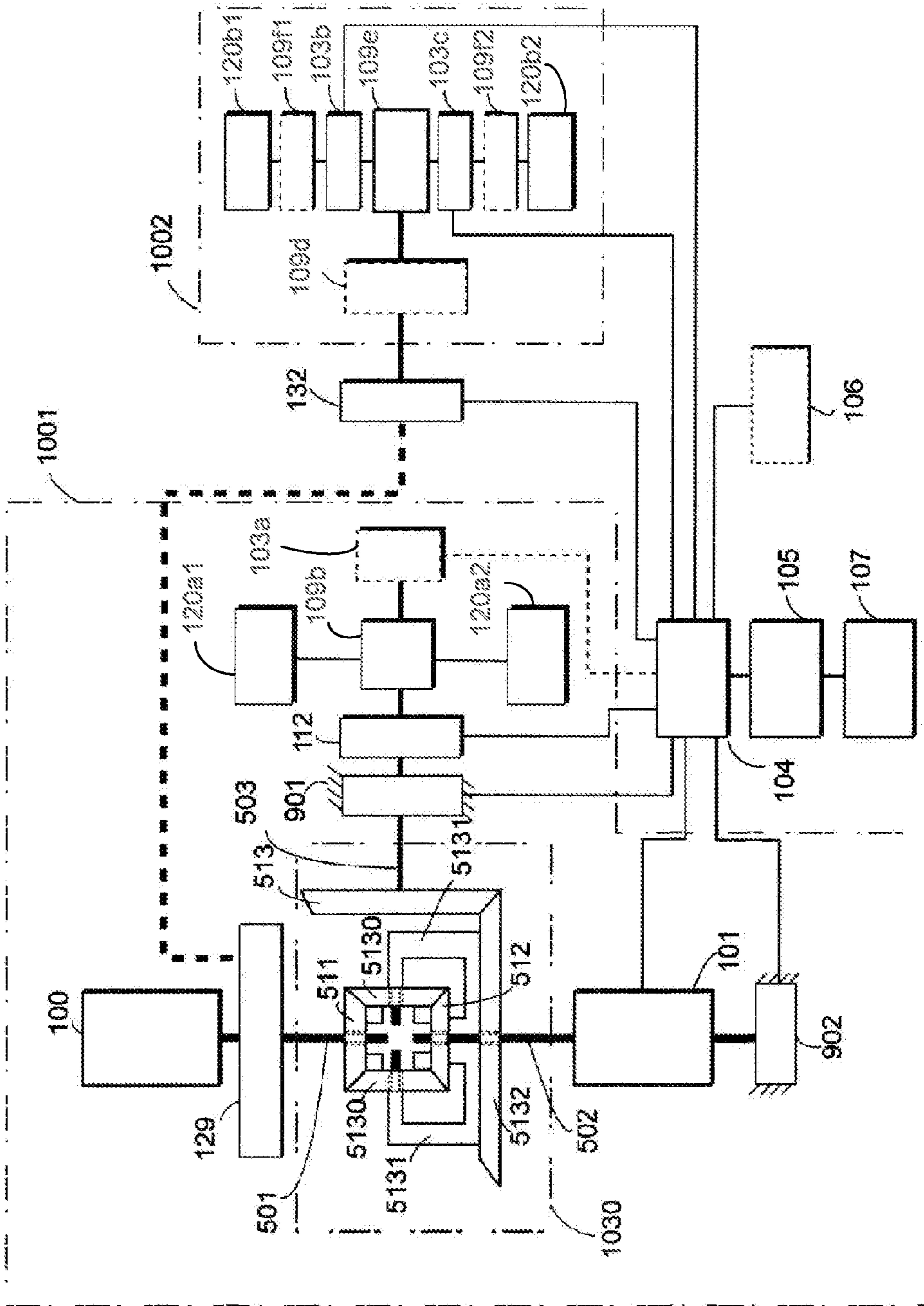

FIG. 24

AMENDED

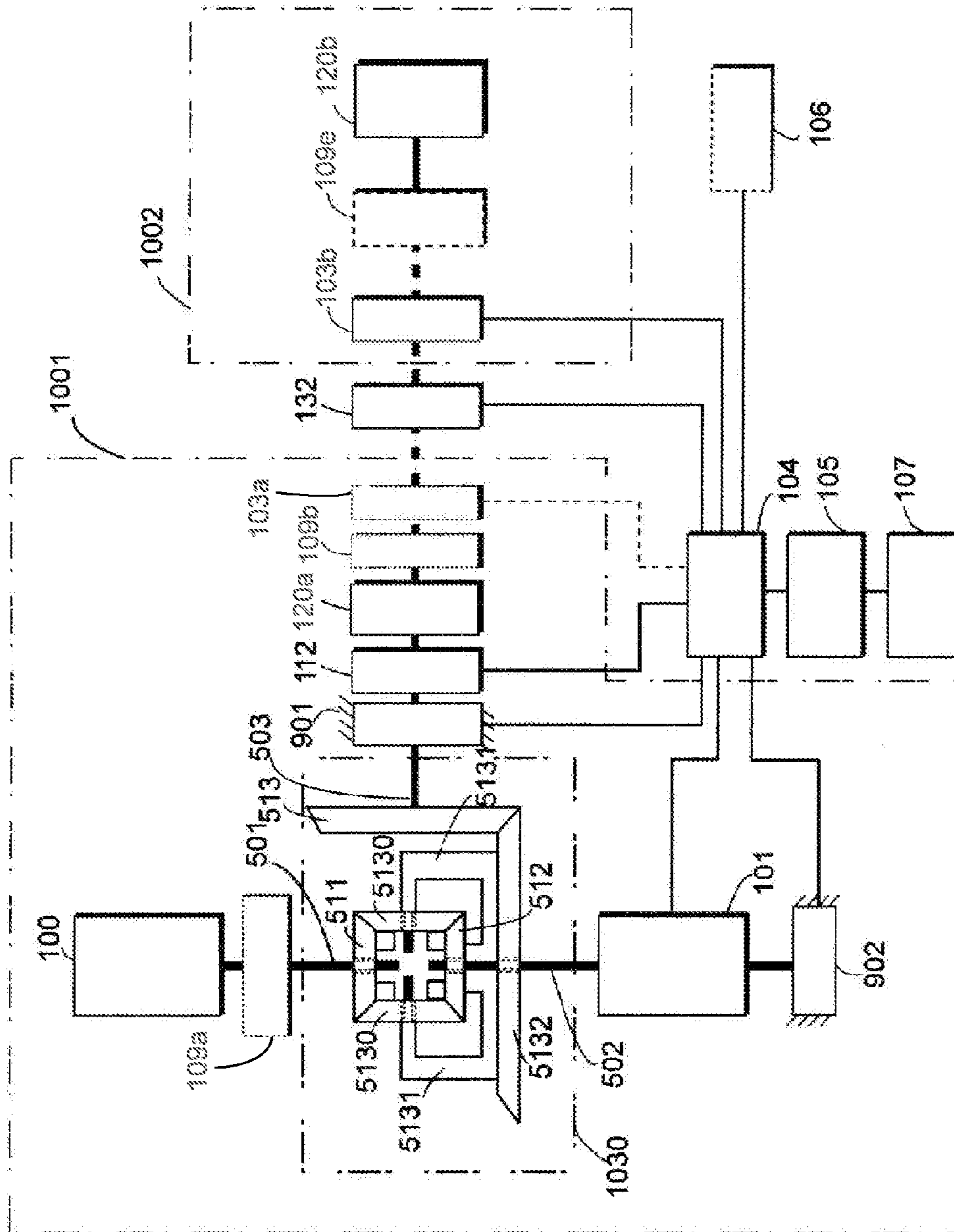

FIG. 25



AMENDED

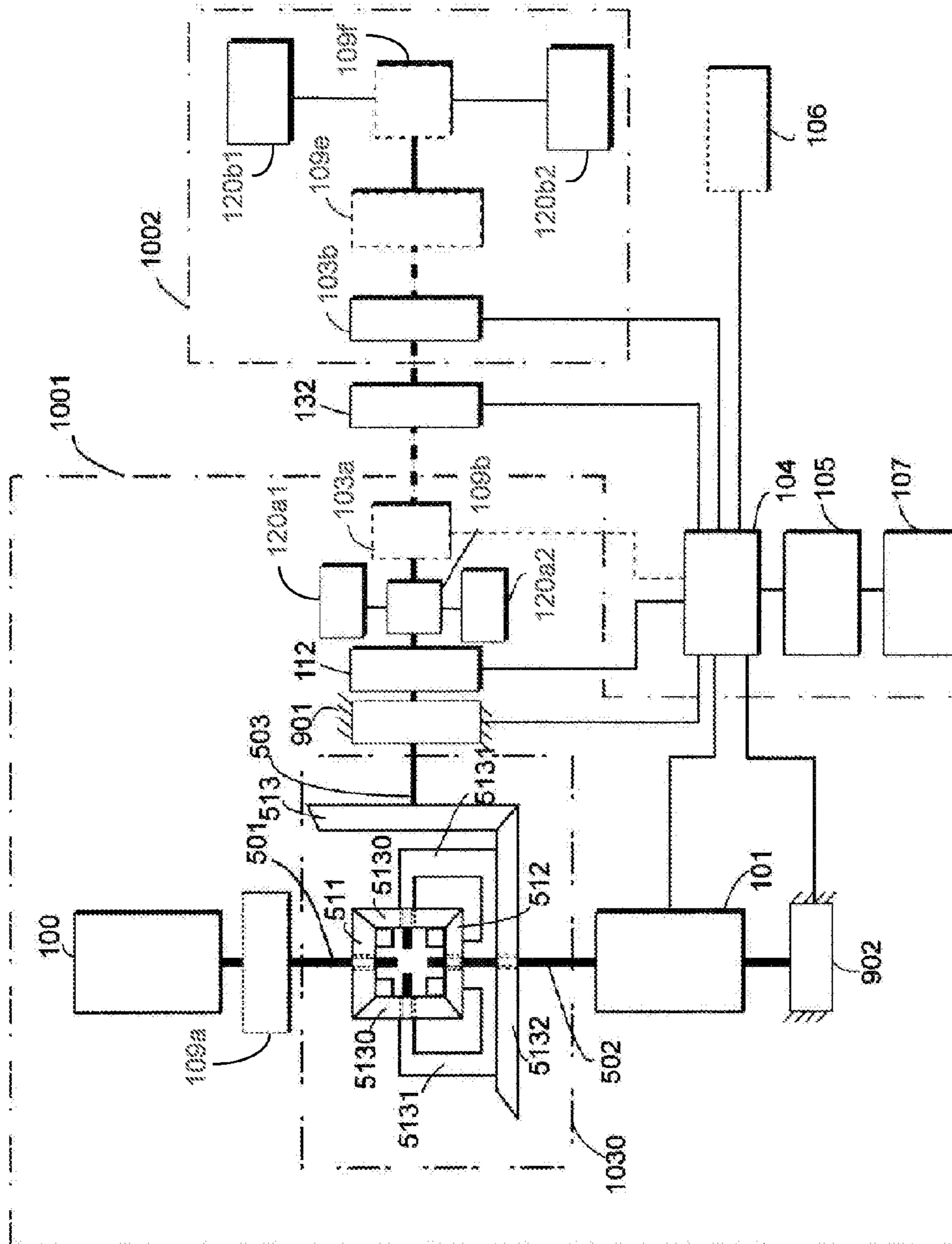

FIG. 26

AMENDED

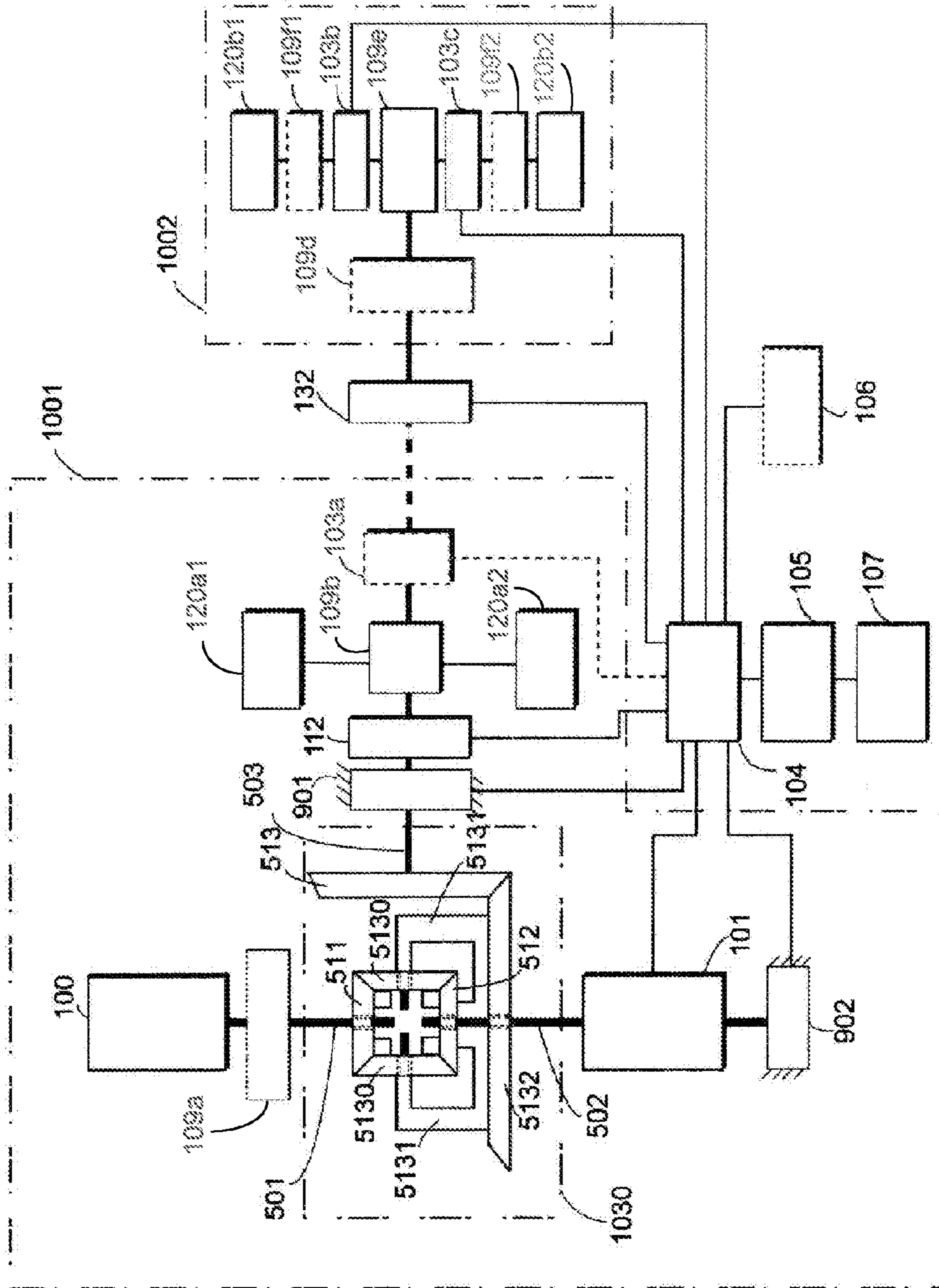

FIG. 27

AMENDED

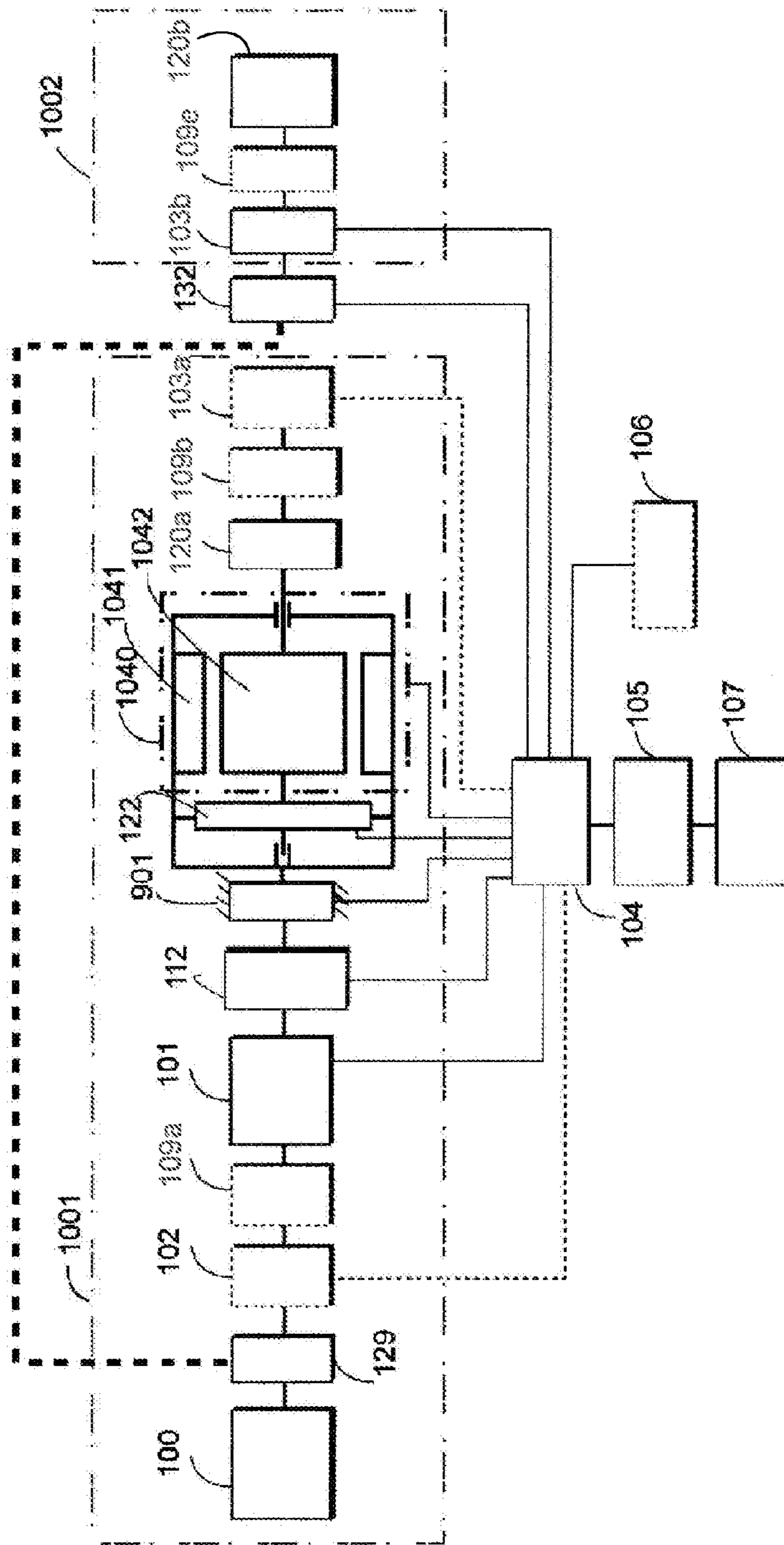

FIG. 28



AMENDED

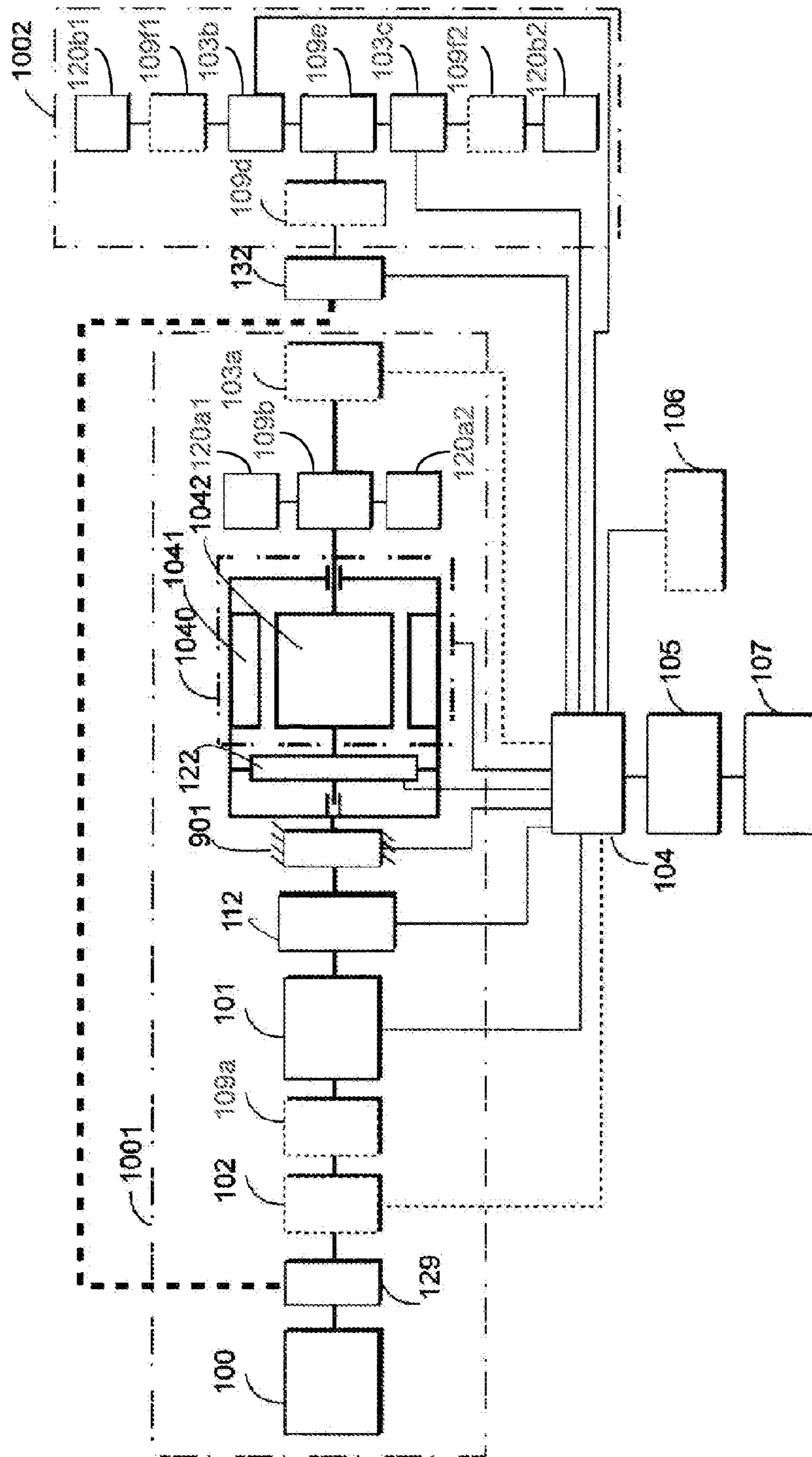

FIG. 30

AMENDED

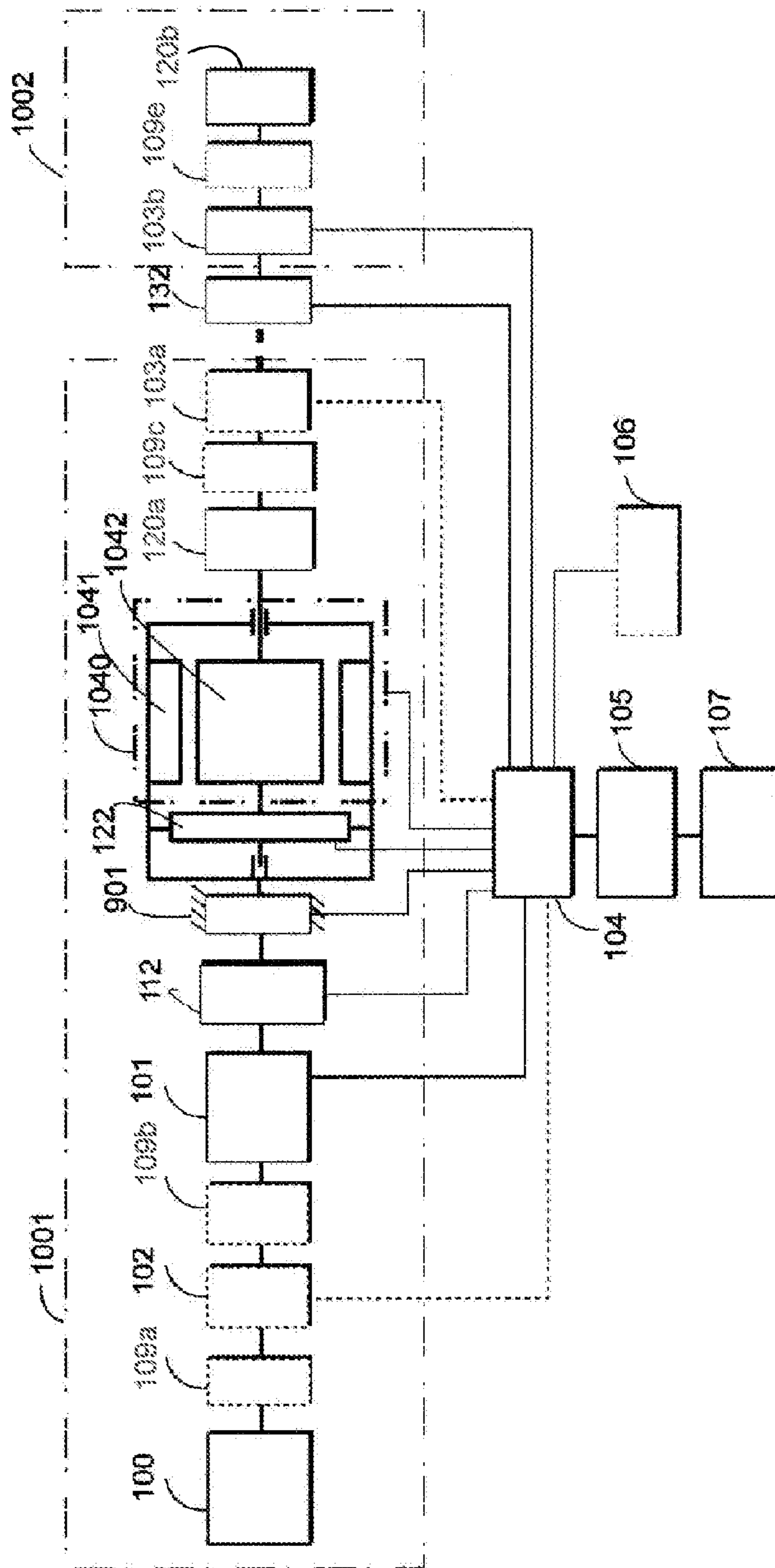

FIG. 31

AMENDED

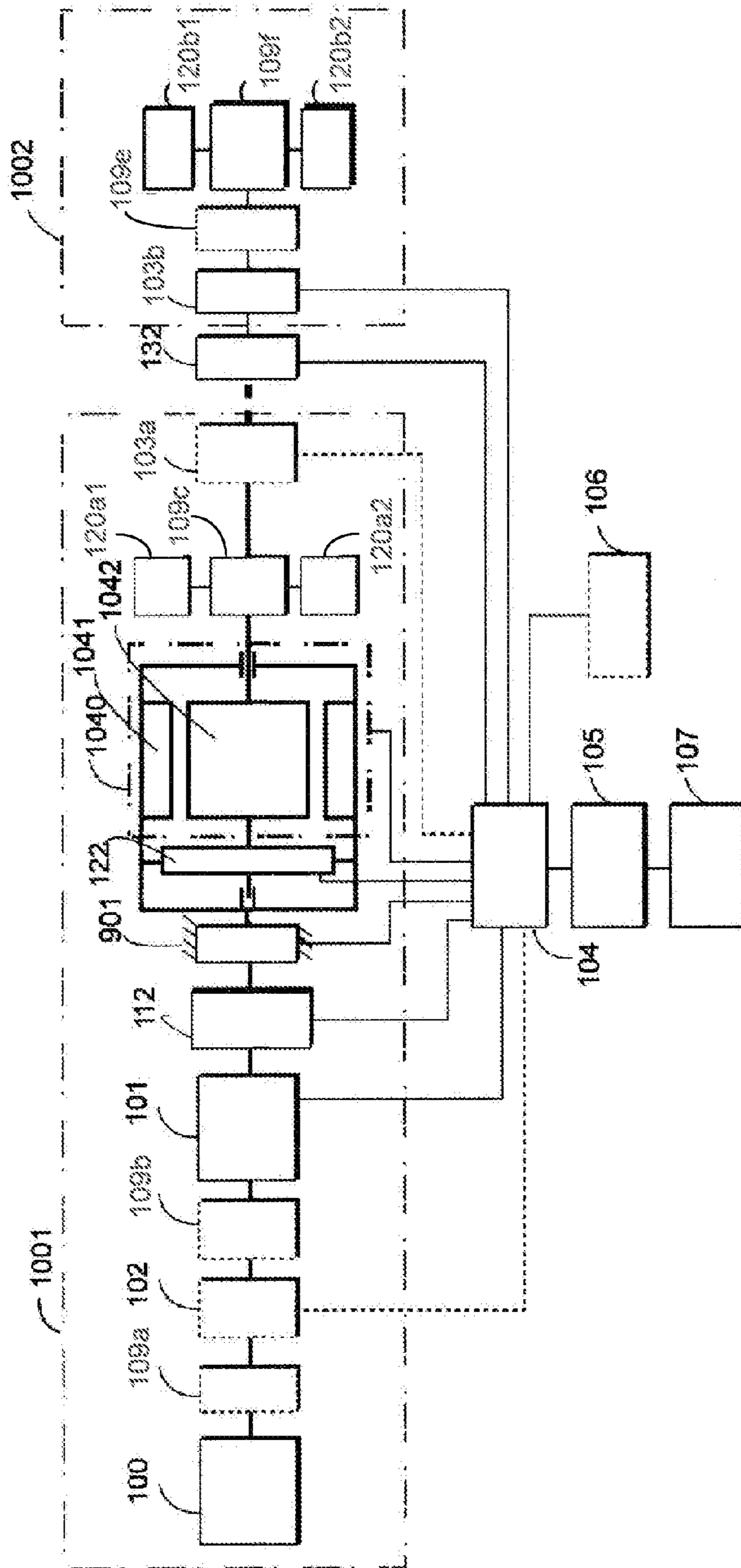

FIG. 32

AMENDED

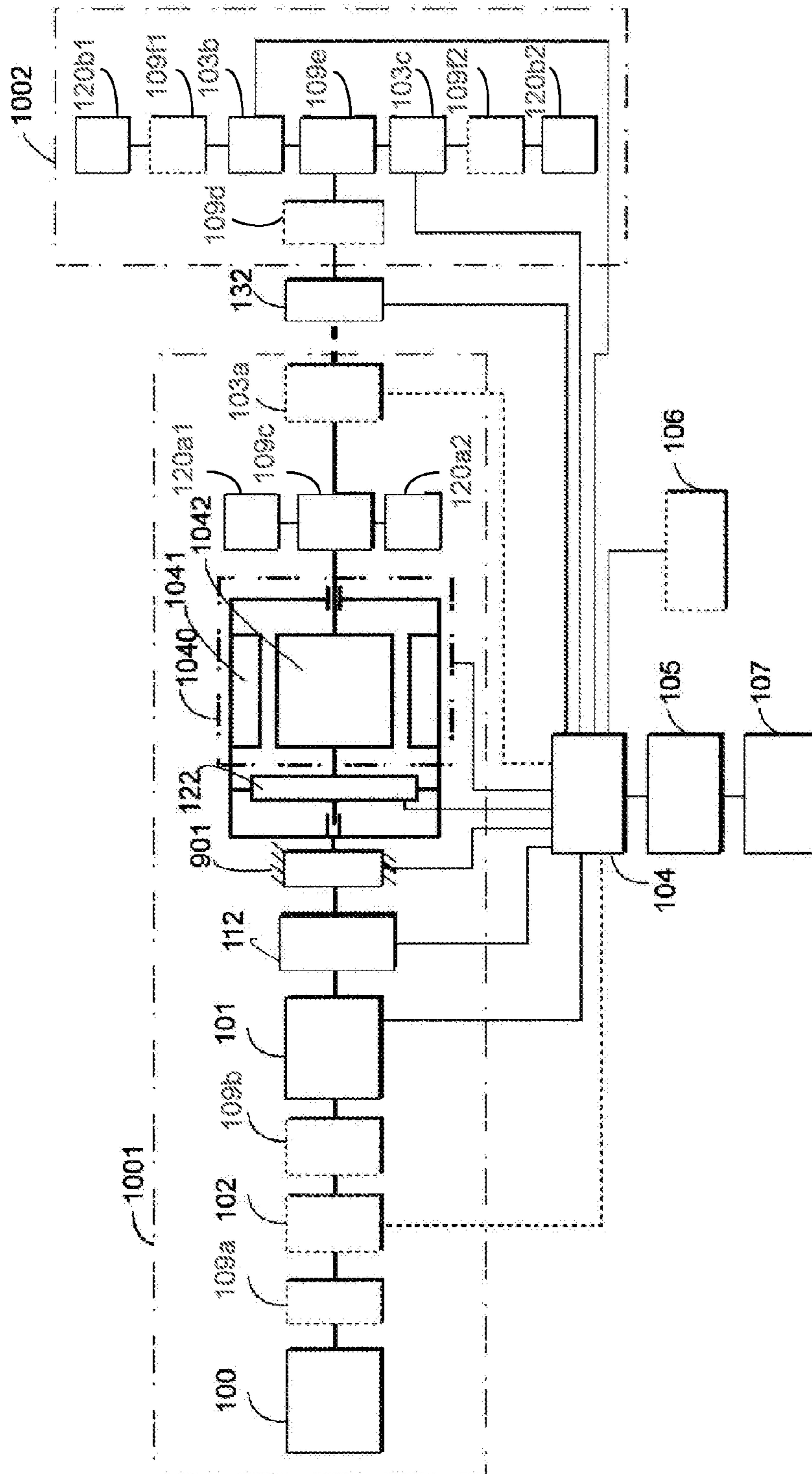

FIG. 33



AMENDED

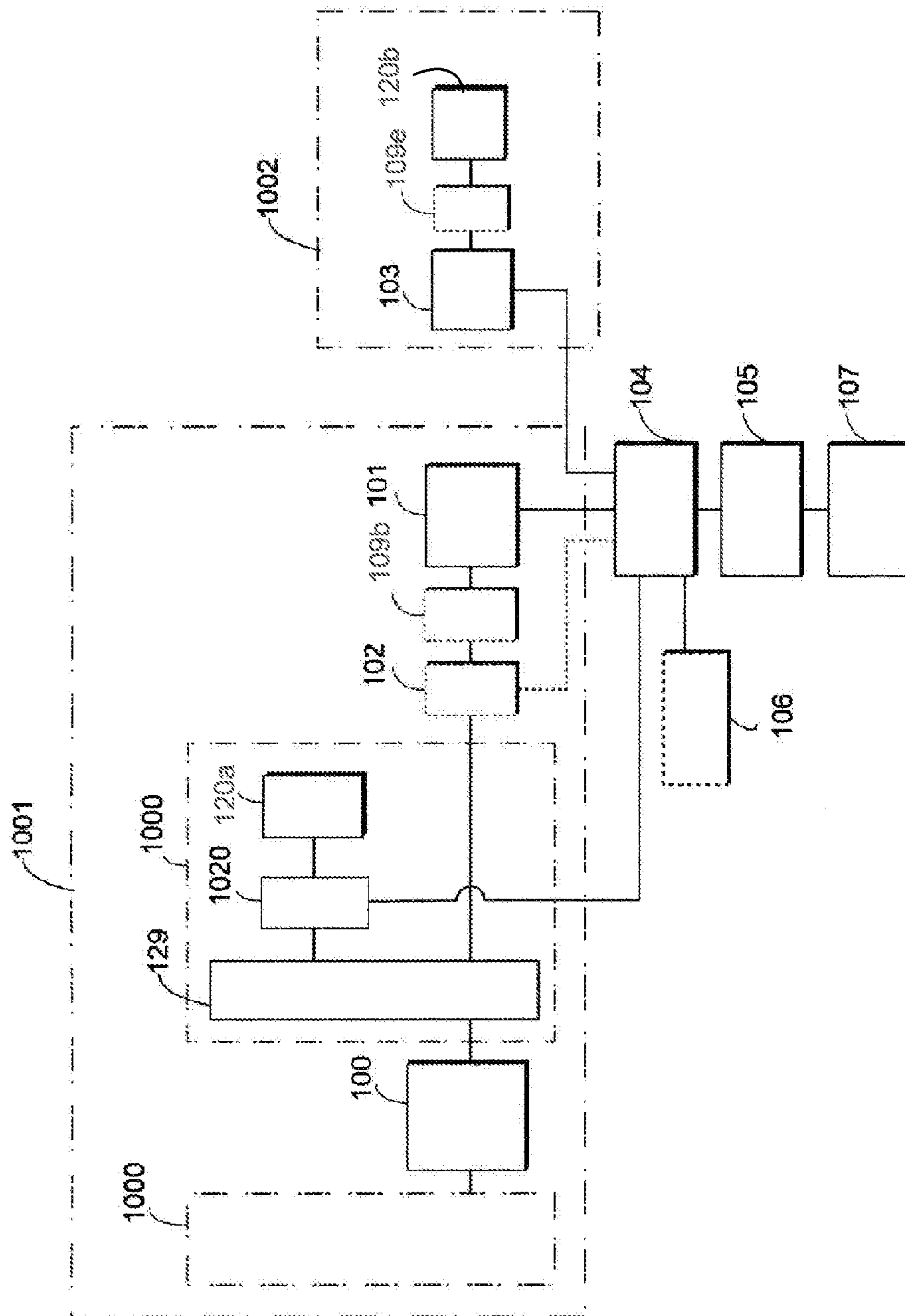

FIG. 34

AMENDED

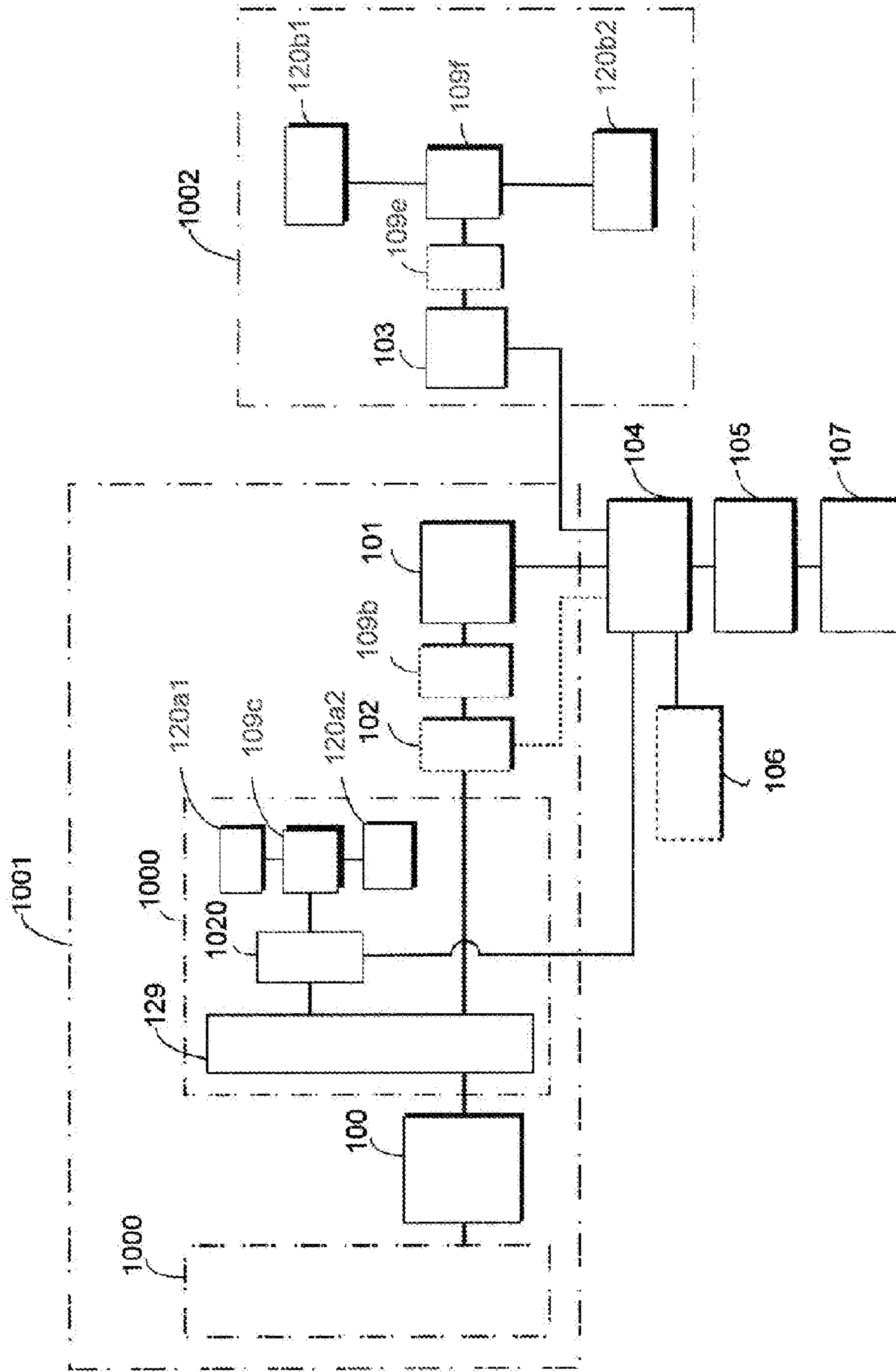

FIG. 35

AMENDED

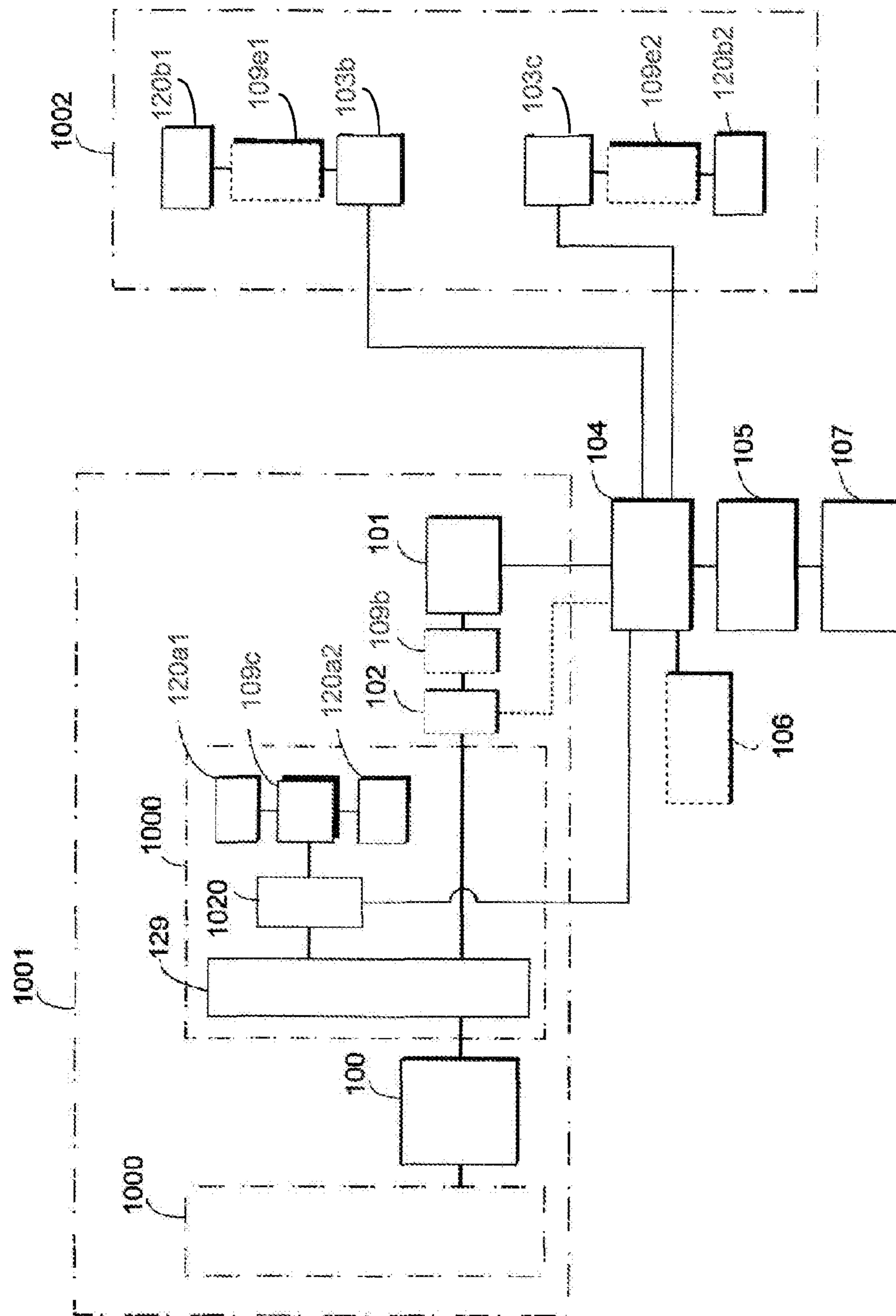

FIG. 36

AMENDED

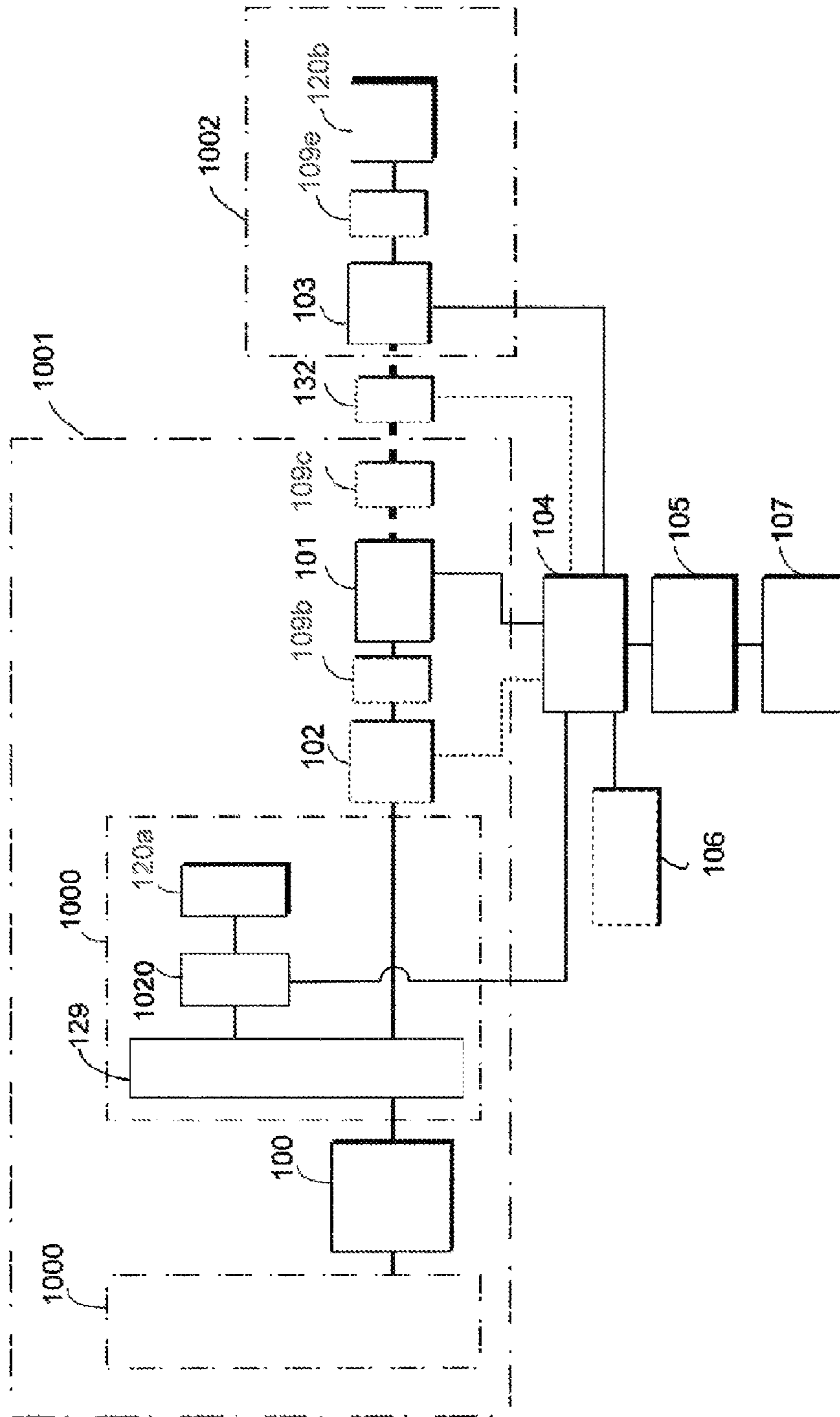

FIG. 37

AMENDED

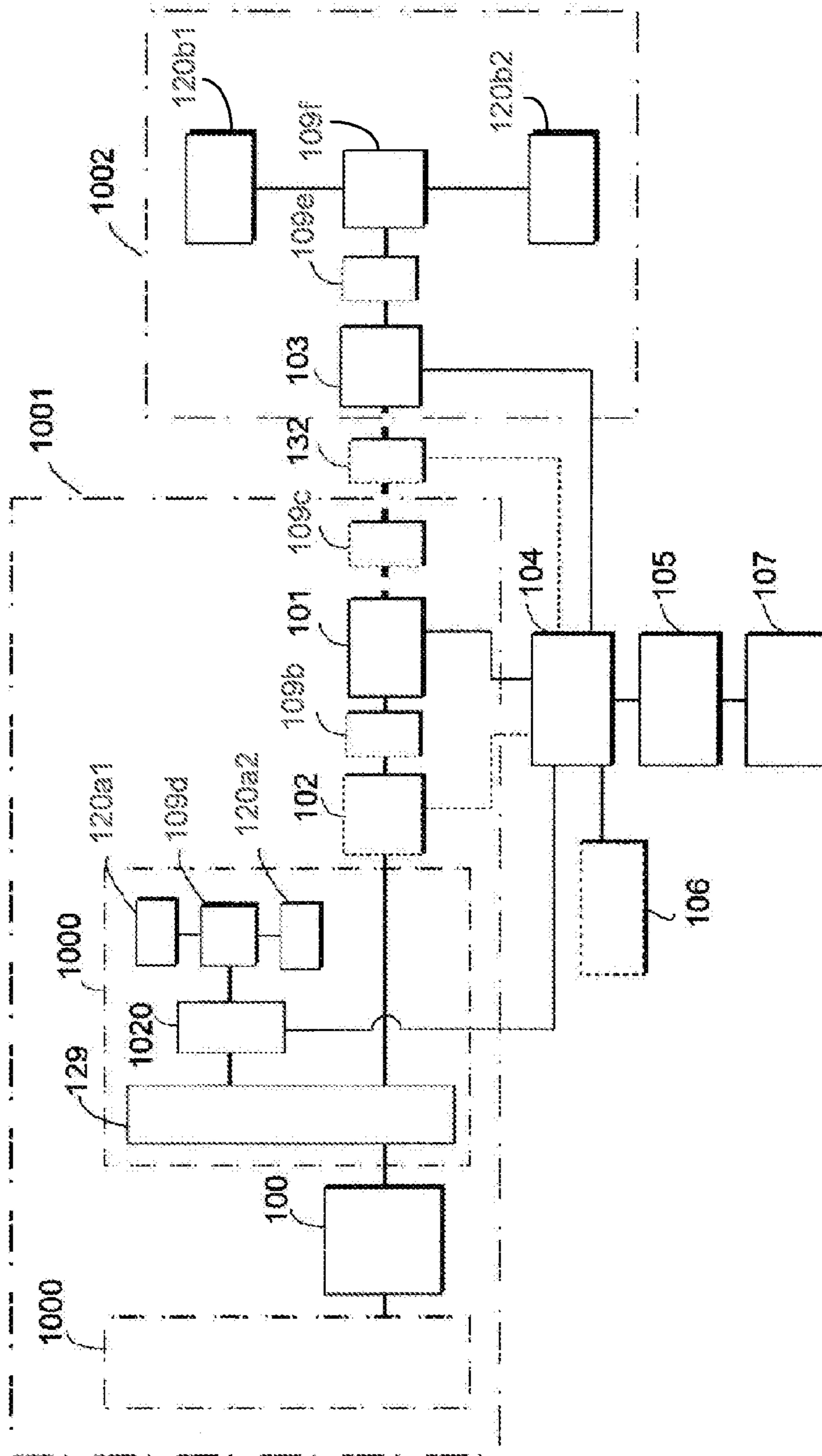

FIG. 38

AMENDED

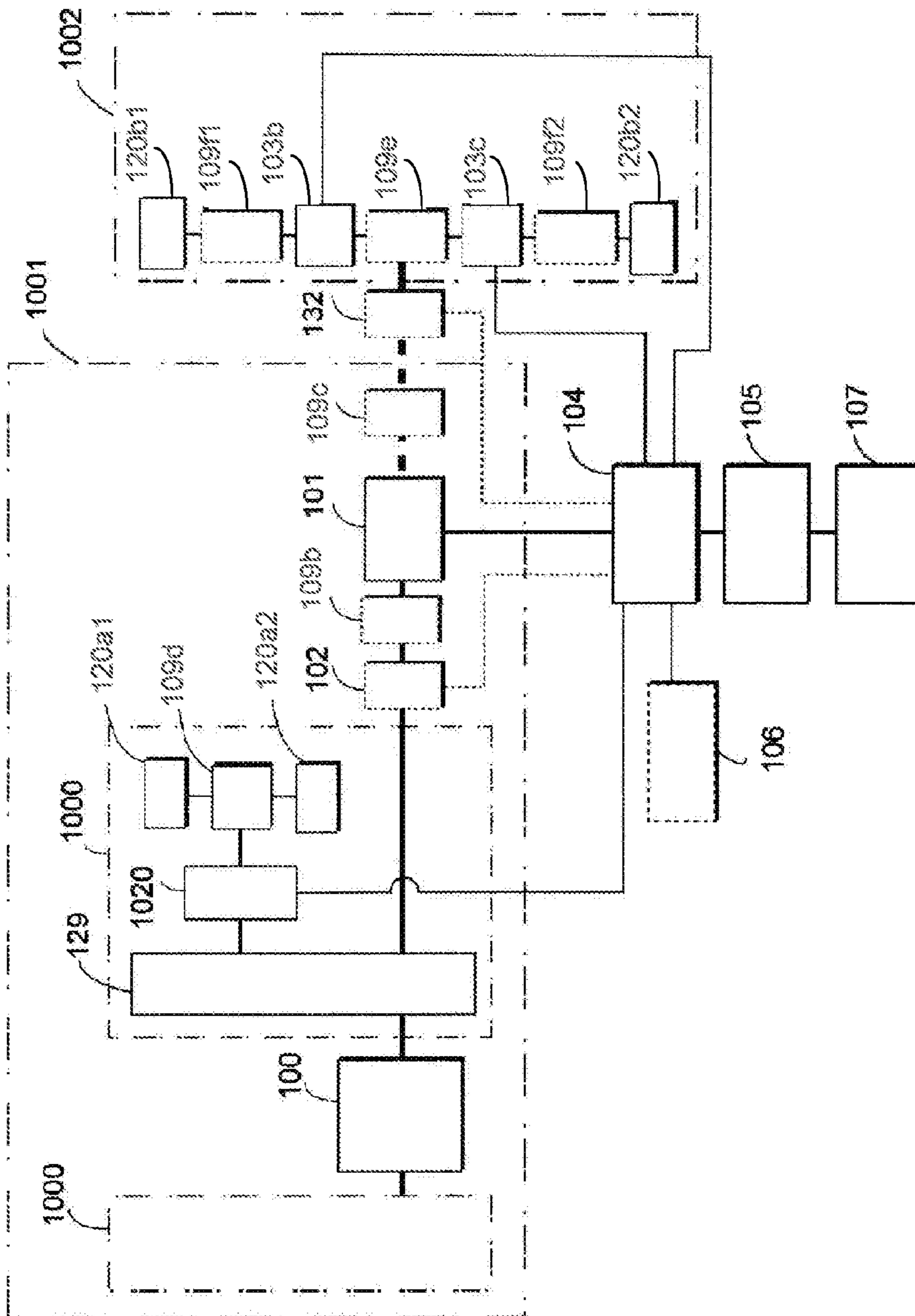

FIG. 39

AMENDED

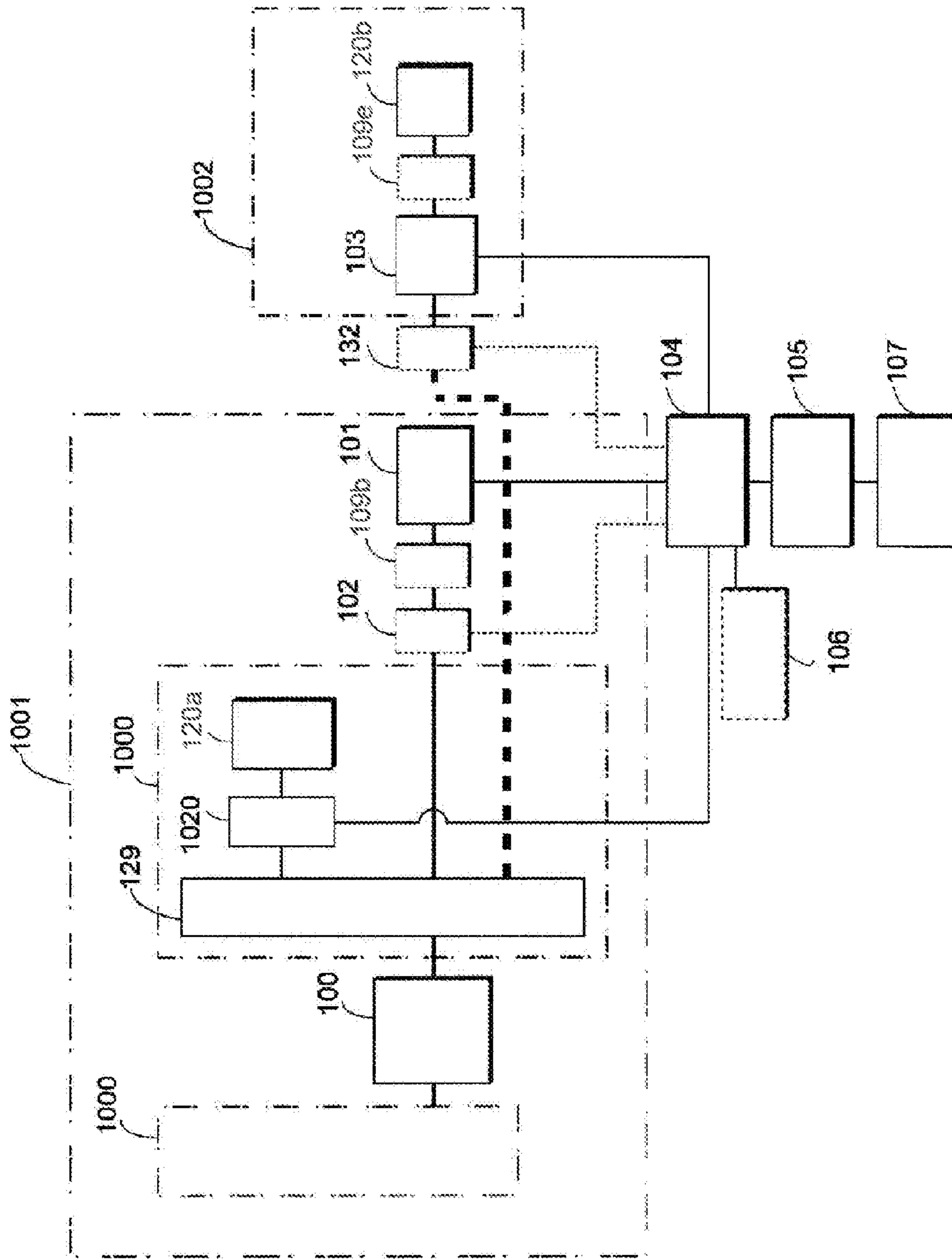

FIG. 40

AMENDED

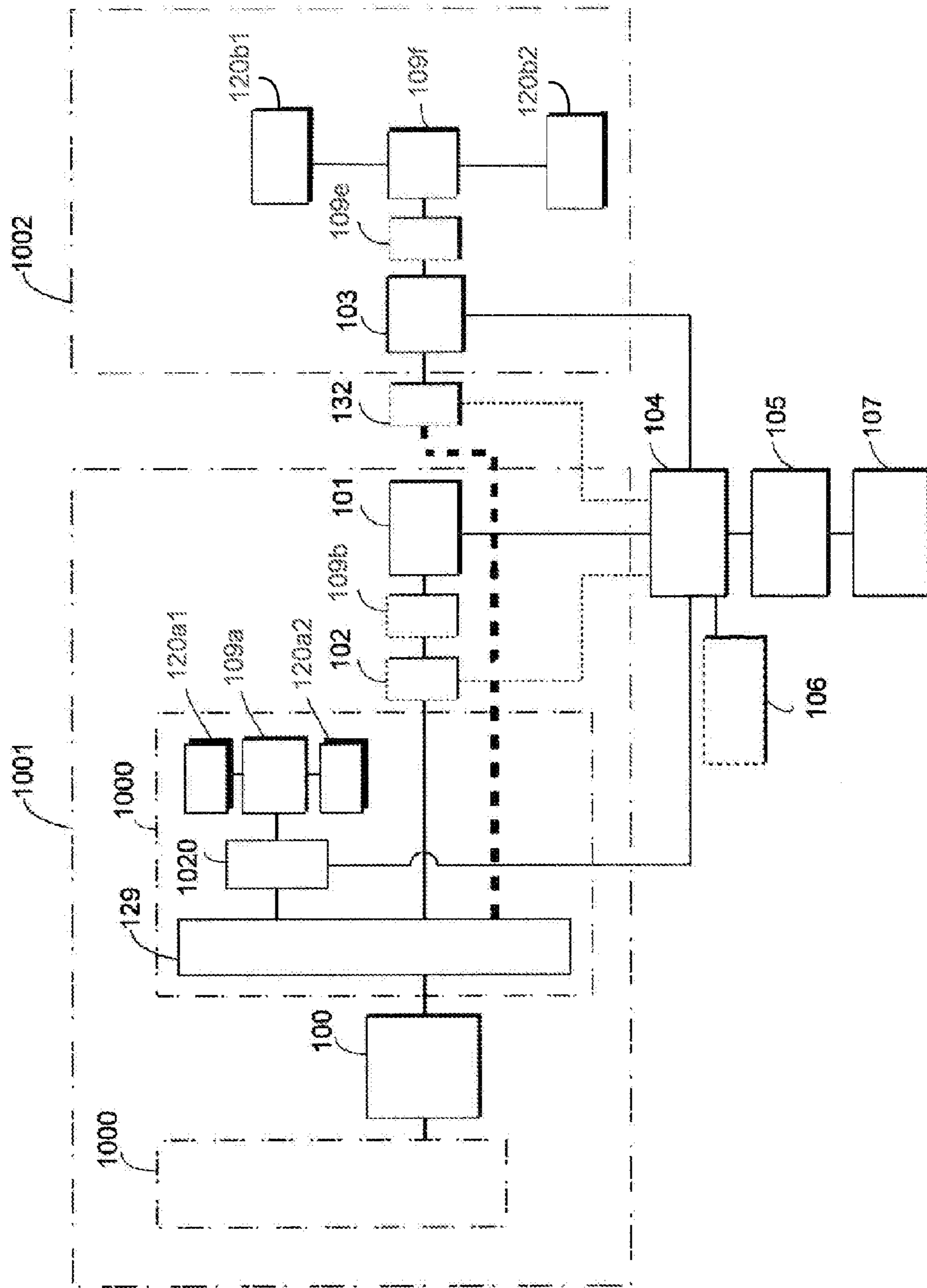

FIG. 41



AMENDED

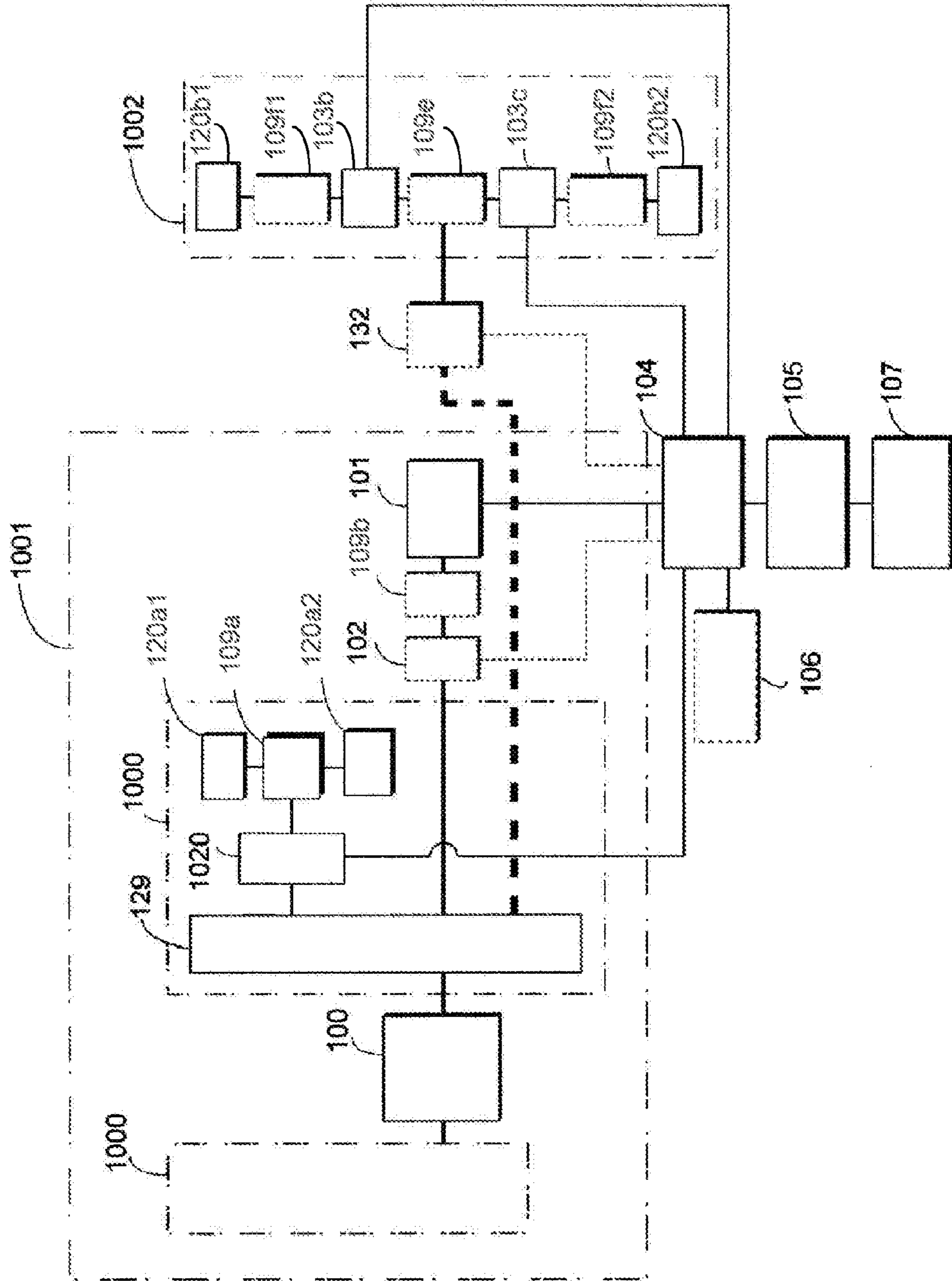

FIG. 42

AMENDED

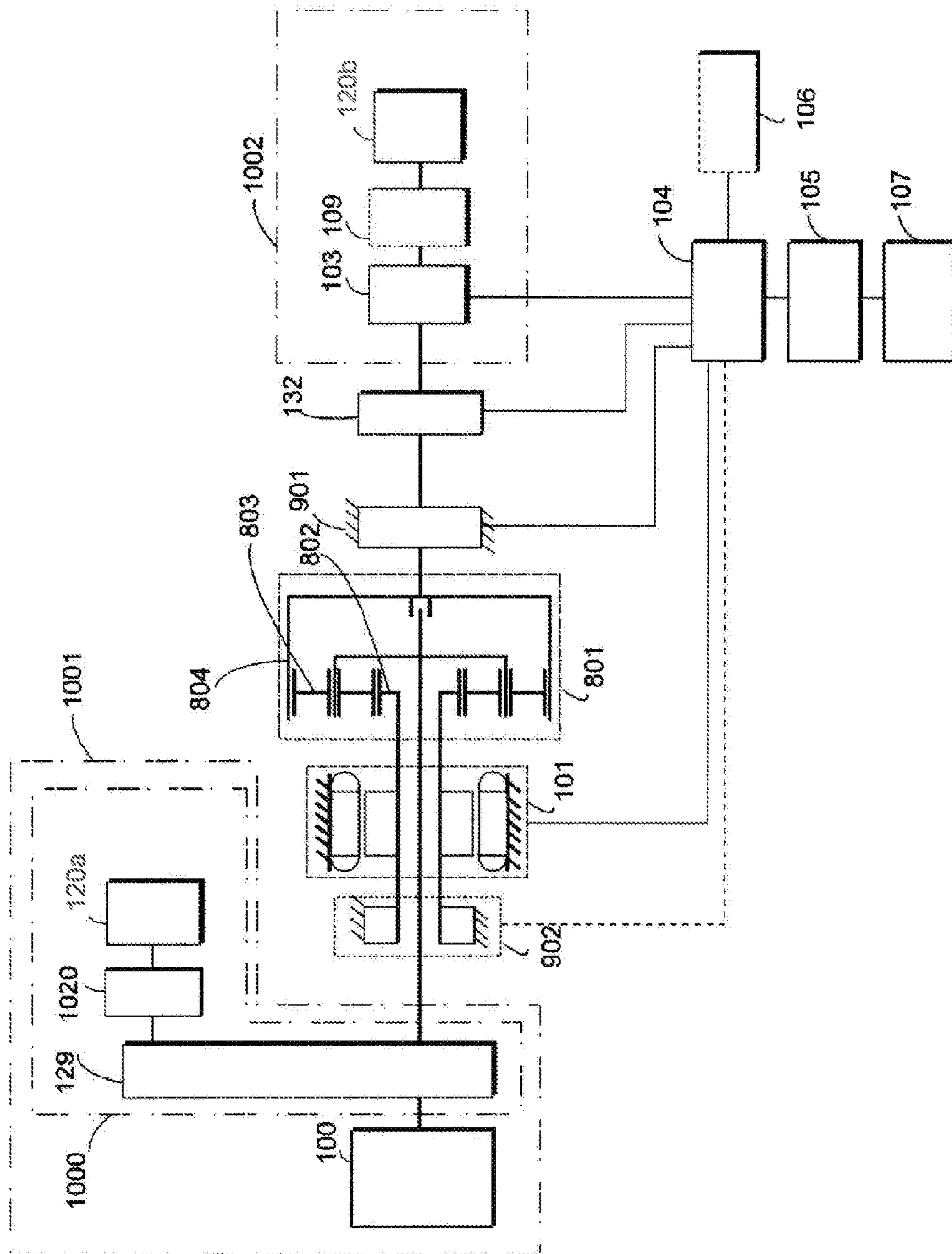

FIG. 43

AMENDED

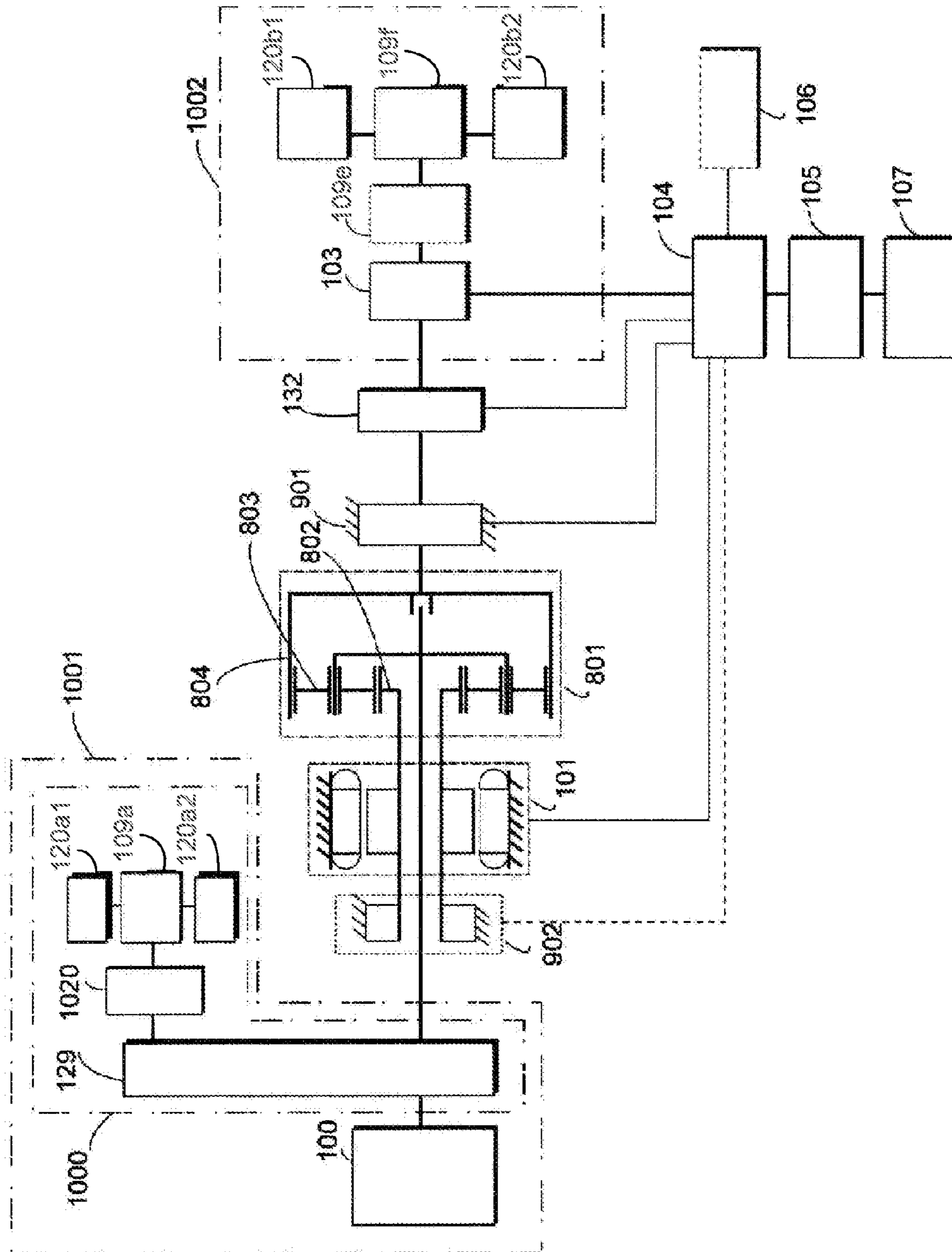

FIG. 44

AMENDED

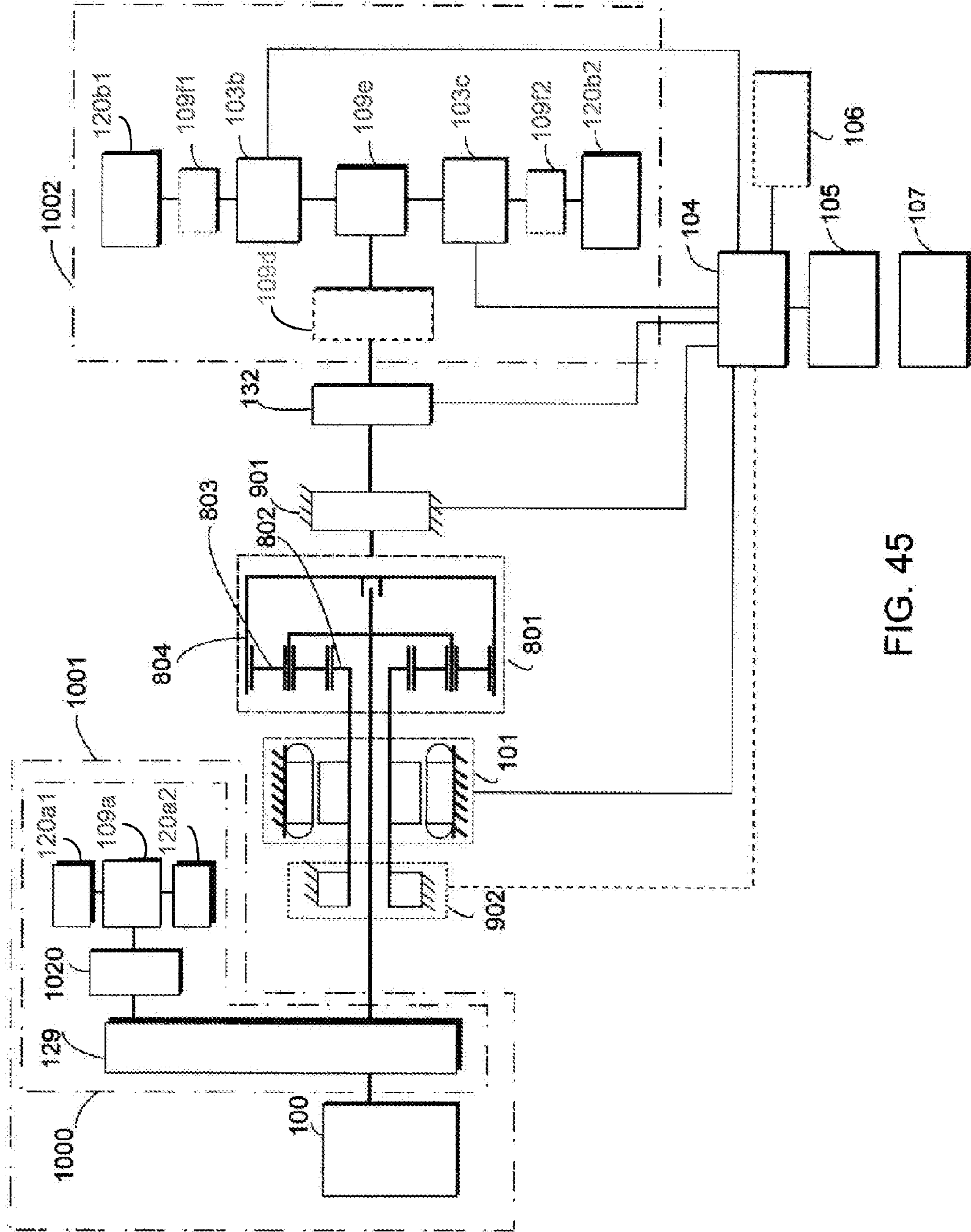

FIG. 45

AMENDED

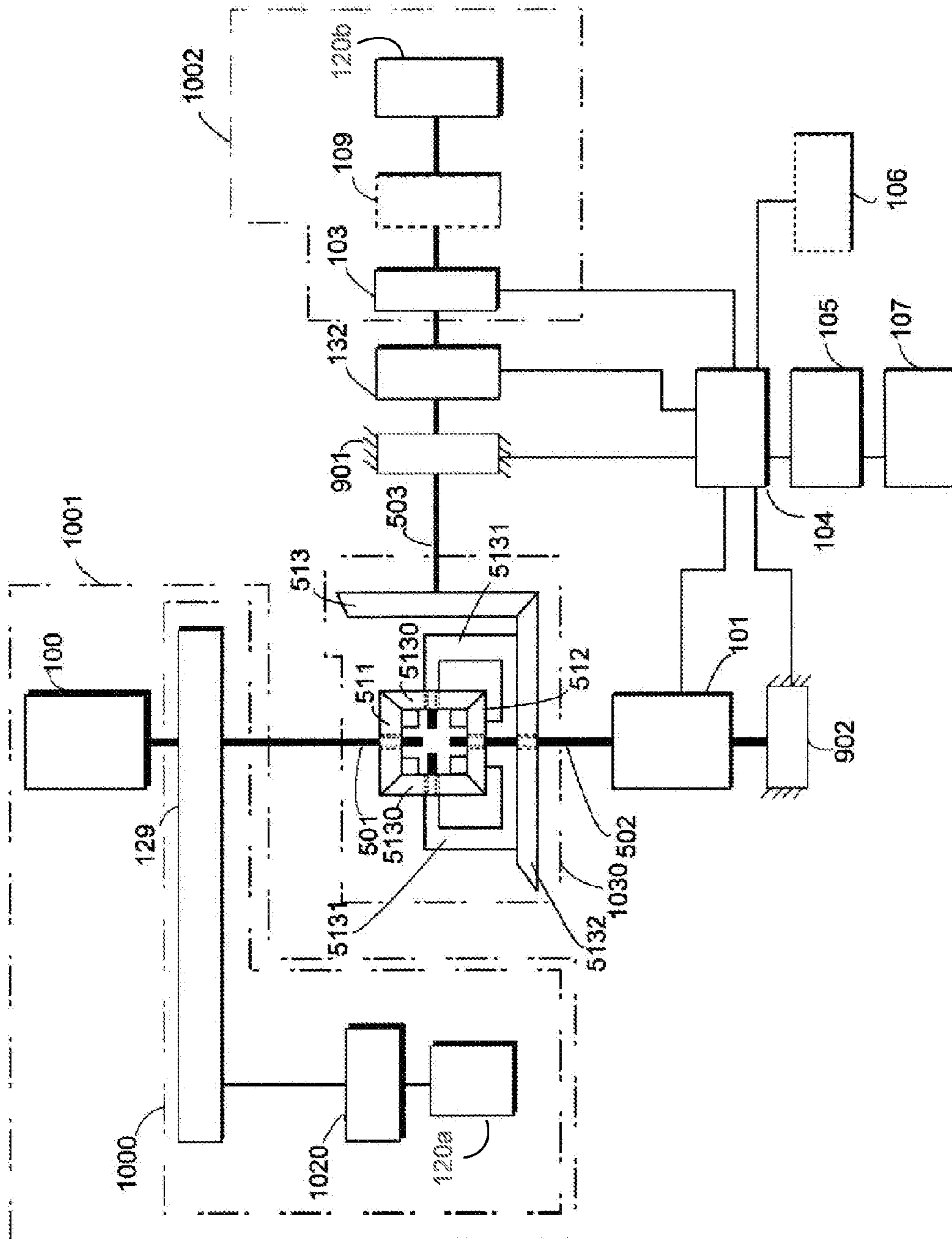

FIG. 46

AMENDED

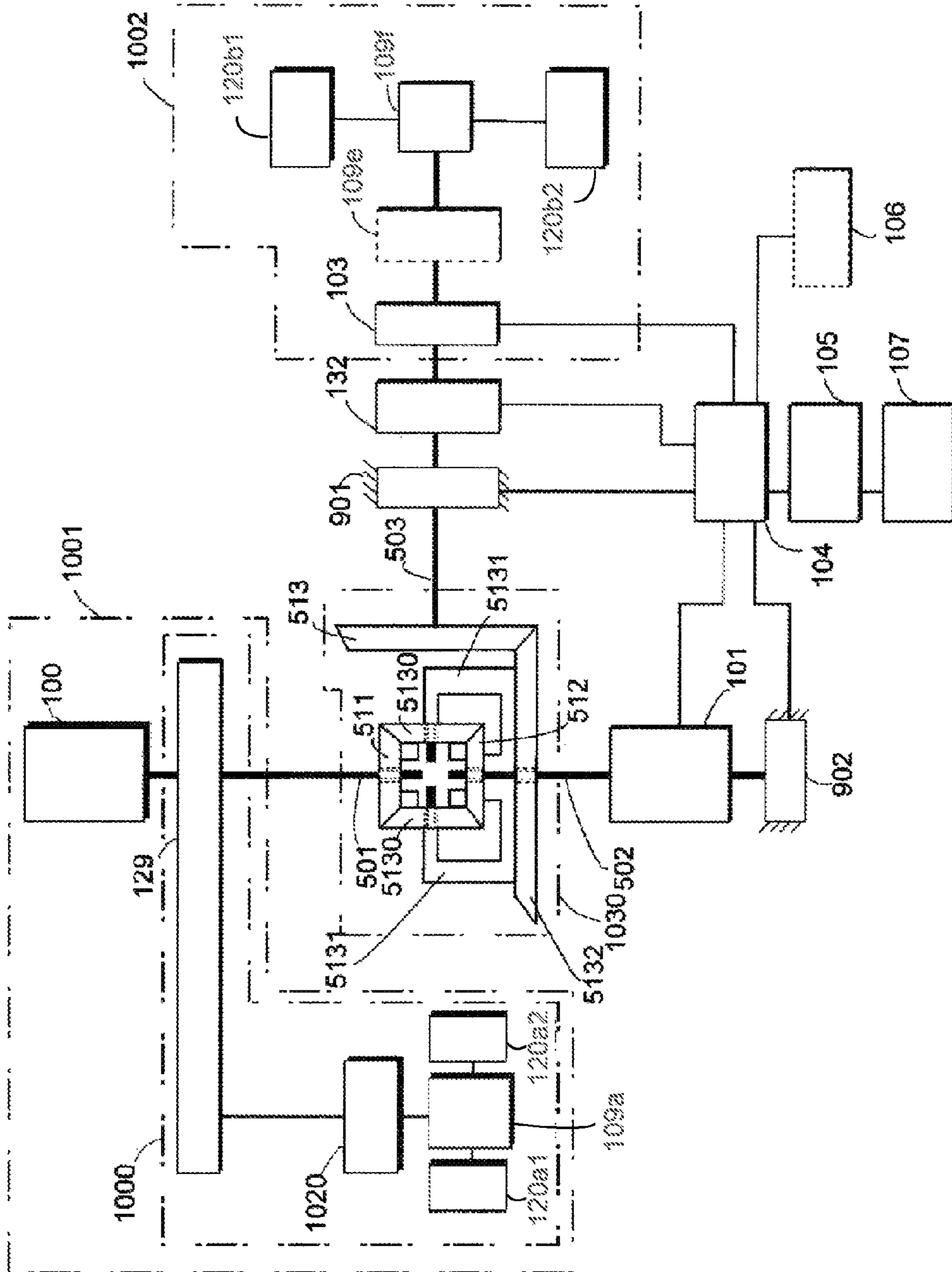

FIG. 47

AMENDED

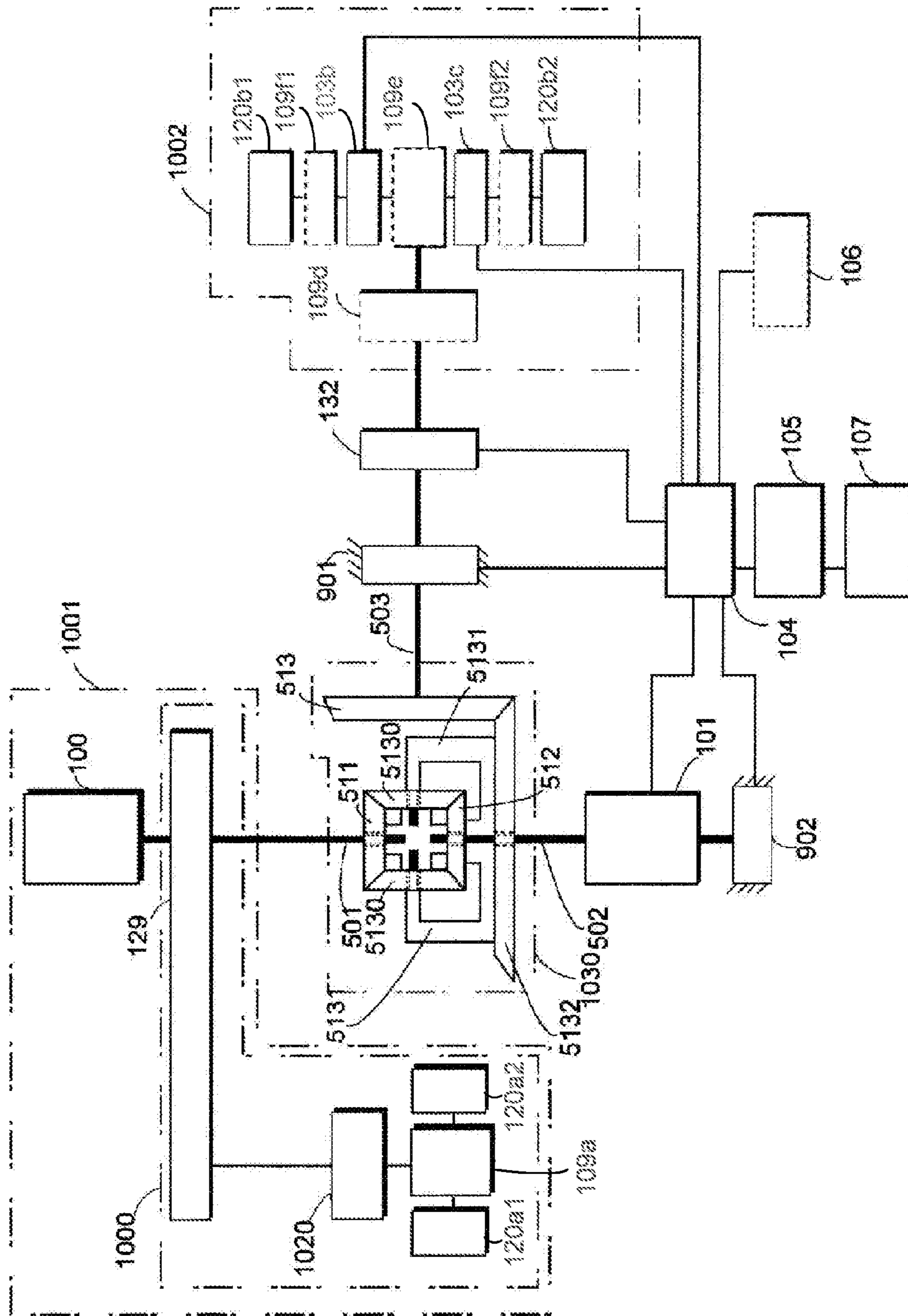

FIG. 48

AMENDED

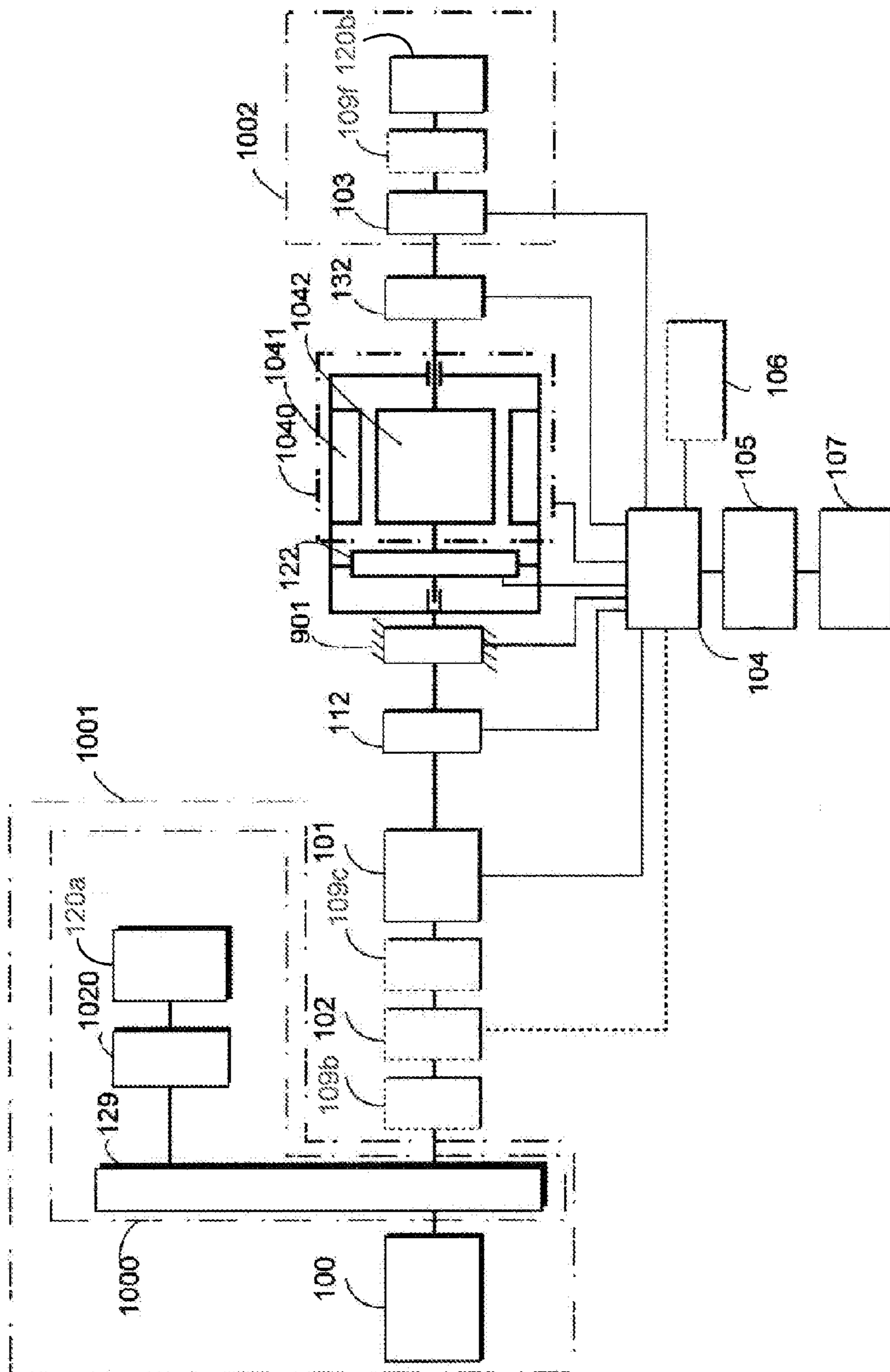

FIG. 49



AMENDED

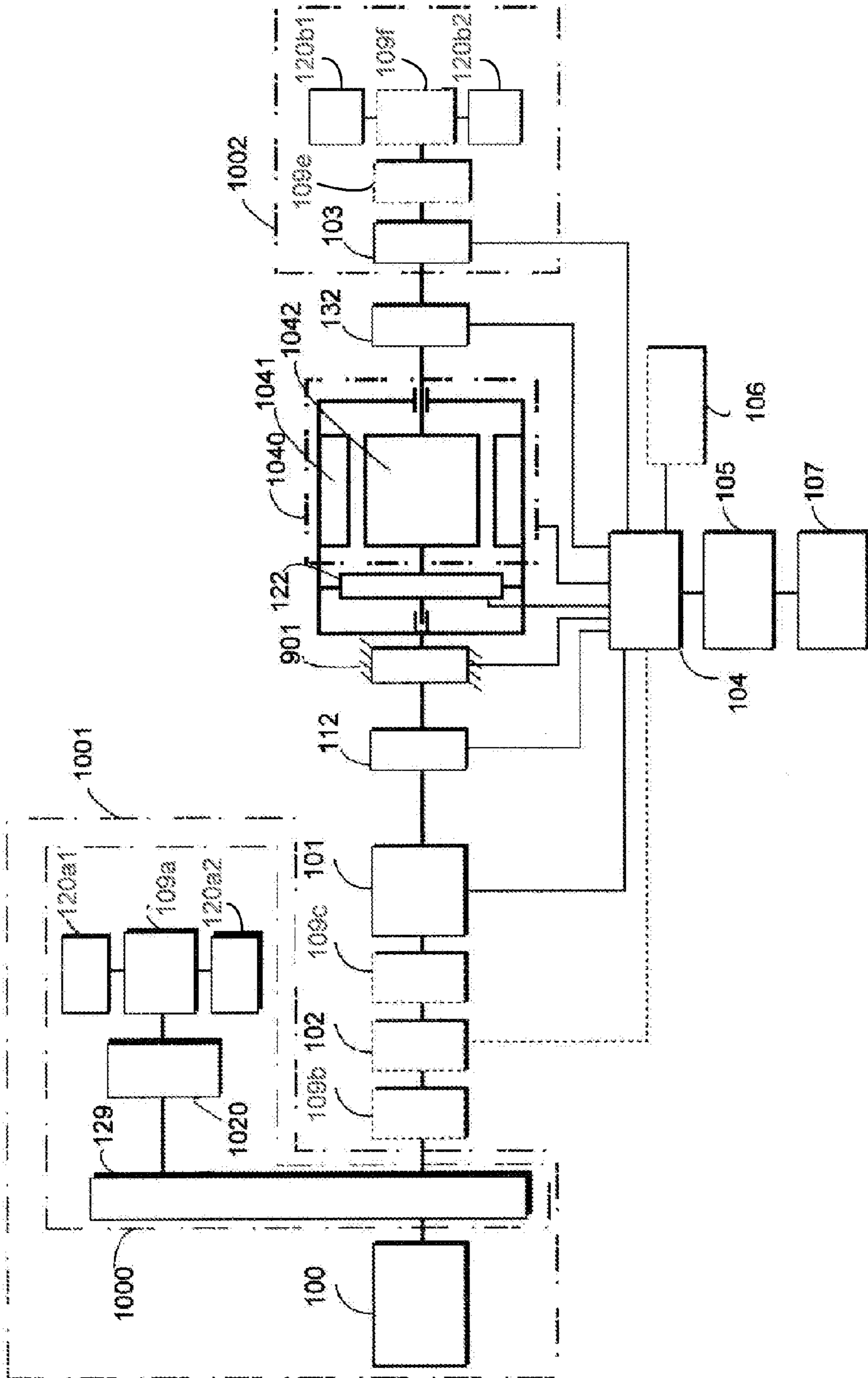

FIG. 50

AMENDED

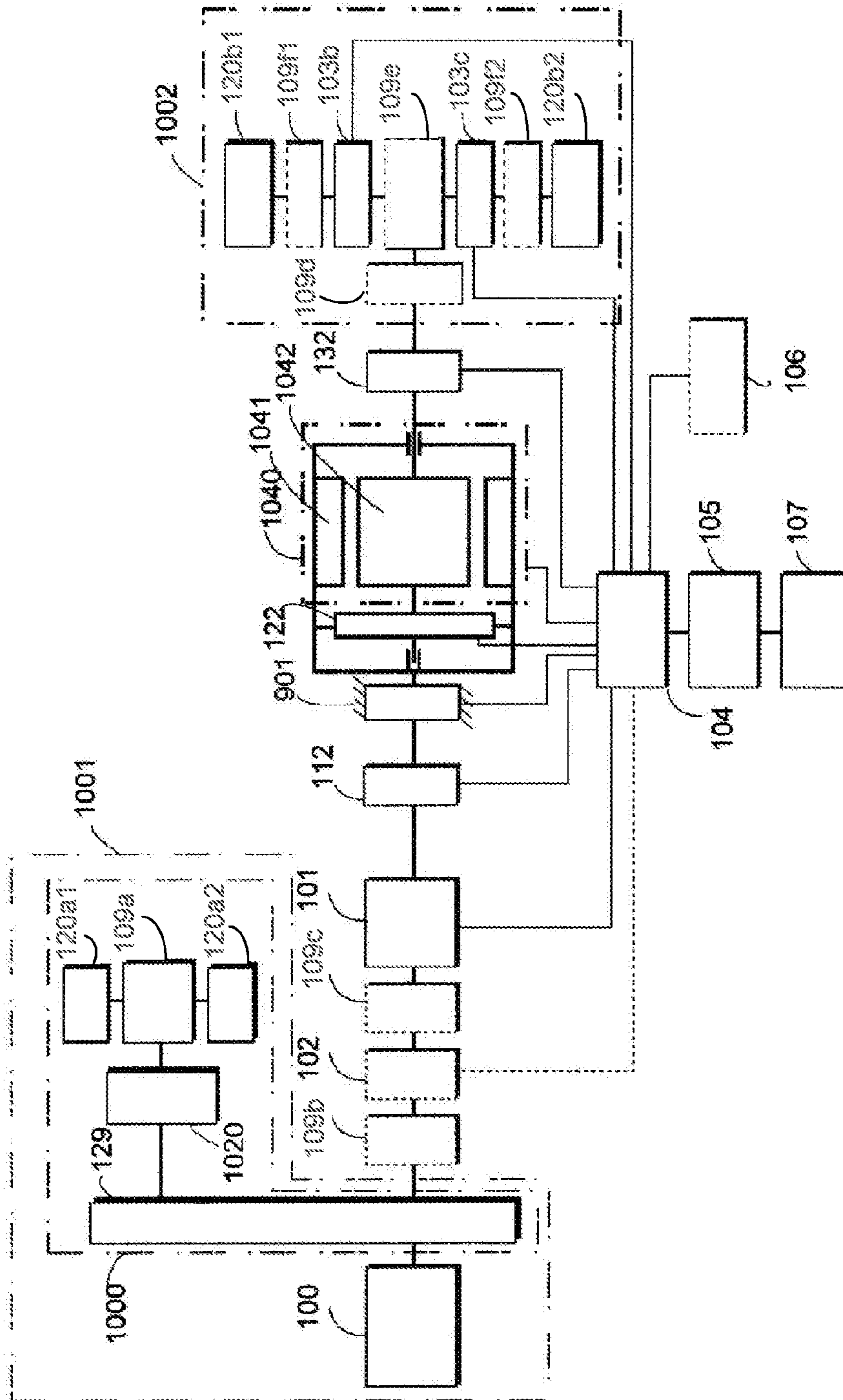

FIG. 51

## SPLIT SERIAL-PARALLEL HYBRID DUAL-POWER DRIVE SYSTEM

**Matter enclosed in heavy brackets [ ] appears in the original patent but forms no part of this reissue specification; matter printed in italics indicates the additions made by reissue; a claim printed with strikethrough indicates that the claim was canceled, disclaimed, or held invalid by a prior post-patent action or proceeding.**

### CROSS-REFERENCE TO RELATED APPLICATION

This is a division of U.S. application Ser. No. 10/975,525, filed Oct. 29, 2004, now U.S. Pat. No. 7,377,876 the entire disclosure of which is incorporated herein by reference.

### BACKGROUND OF THE INVENTION

#### (a) Field of the Invention

The present invention is related to a split serial-parallel hybrid dual-power drive system, and more particularly to one used to drive land, maritime, underwater or aerospace transportation means, or industrial machines and equipment or any other load driven by rotational kinetic energy.

The split serial-parallel hybrid dual-power drive system is comprised of two or more than two separation drive systems allowing independent operation to respectively drive the load, or all loads driven individually are incorporated in a common frame.

In the separation drive system of the dual-power drive system, the first drive system and a second drive system are provided. The first drive system is equipped with an active power source, a first electrical unit essentially functioning as a generator, and an optional second electrical unit essentially functioning as a motor, and a clutch set to control the transmission status of the rotational kinetic energy; and the second drive system is adapted with another second dynamo-electric unit essentially functioning as a motor to serve as the rotational power source for the second drive system.

An optional clutch set is provided to control the transmission or cut-off of the rotational kinetic energy between two independent drive systems.

By means of the regulation of a control system or by manual operation, the status of transmission between the active rotational power source and the first dynamo-electric unit of the separation serial-parallel hybrid drive system indicates a coupled status; and the active rotational kinetic energy source drives the first dynamo-electric unit to output electric power to further drive the second dynamo-electric unit to operate as a motor to provide functions related to a series hybrid power train; or alternatively, through the control and operation of the clutch, the rotational kinetic energy from the active rotational power source outputs rotational kinetic energy to drive either or both of the loads of the first drive system and the second drive system; or the active rotational power source is incorporated to both of the first and the second dynamo-electric units, and an optional rechargeable device to provide functions related to a parallel hybrid power train. Accordingly, the present invention relates to an innovative dual-power drive system by providing more operation functions.

#### (b) Description of the Prior Art

Traditional transportation means on land, maritime or air-borne is usually related to a single acting power train. To meet energy saving and pollution control criteria significant efforts

have been devoted to the development of dual-power drive system in recent years. Among these efforts, the development of a power train combining the rotational kinetic energy outputted from engine and that from electricity driven motor has made quite an impressive progress. The hybrid dual-power system of the prior art includes:

1. Serial hybrid power drive system: a generator is driven by an engine to further drive a motor to produce rotational kinetic energy to drive a load, this system has reported flaws of wild variation in system efficiency under various loading condition; greater demand on electrical power capacity, requiring larger installation space, heavier and higher cost due to that both of the motor and the generator have to carry all the power consumption.
2. Rechargeable serial drive system: Under normal loading, an engine drives a generator to further drive a motor to output rotational kinetic energy for driving a load. Under light loading condition, electric energy from the generator is partially flow into a rechargeable energy storage device for storage. While the engine stops running, the electrical energy inside storage device will output to the motor for producing the rotational kinetic energy to drive the load, this approach brings higher energy efficiency and less pollution; and under heavy loading, electrical energy from the engine-driven-generator and from the rechargeable energy storage device are transferred to the motor which output rotational kinetic energy for driving the load.
3. Parallel hybrid power train: Under normal loading, rotational kinetic energy outputted from an engine directly drive the load; Under light loading, the motor driven by the engine is switched into the generator mode for charging the rechargeable device or supply power to other load, or if the engine stops running, the rechargeable device drives the motor to output rotational kinetic energy to drive the load for higher energy efficiency and less pollution. Under heavy loading, the rotational kinetic energy outputted from the engine and that from the motor driven by the rechargeable device jointly drive the load. However, the flaw of the system is that it requires the installation of a rechargeable device with sufficient electrical capacity.

### SUMMARY OF THE INVENTION

The primary purpose of the present invention is to provide to split serial-parallel hybrid dual-power drive system comprised of two or more than two separation drive units to drive their respective loads, or all loads are incorporated into a common frame. An optional clutch is adapted to control transmission or cut-off of the rotational kinetic energy between independent drive units. The system of the present invention executes specific serial hybrid power train or parallel hybrid power train functions by manual control or by a control system.

### BRIEF DESCRIPTION OF THE DRAWINGS

FIG. 1 is a system block diagram of the present invention.

FIG. 2 is a block diagram of the first preferred embodiment of a split serial-parallel hybrid dual-power drive system.

FIG. 3 is a block diagram of the second preferred embodiment of a split serial-parallel hybrid dual-power drive system.

FIG. 4 is a block diagram of the third preferred embodiment of a split serial-parallel hybrid dual-power drive system.

FIG. 5 is a block diagram of the fourth preferred embodiment of a split serial-parallel hybrid dual-power drive system.

FIG. 6 is a block diagram of the fifth preferred embodiment of a split serial-parallel hybrid dual-power drive system.



## 5

FIG. 49 is the sixteenth block diagram showing that a pilot drive unit is provided to the output terminal of the active rotational power source of the present invention.

FIG. 50 is the seventeenth block diagram showing that a pilot drive unit is provided to the output terminal of the active rotational power source of the present invention.

FIG. 51 is the eighteenth block diagram showing that a pilot drive unit is provided to the output terminal of the active rotational power source of the present invention.

#### DETAILED DESCRIPTION OF THE PREFERRED EMBODIMENTS

The present invention related to a split serial-parallel hybrid dual-power drive system for the operation of a separation serial hybrid power train or a parallel hybrid power train includes an active rotational power source which frequently implemented by an internal combustion engine; a first drive system comprised of a first dynamo-electric unit essentially functioning as a generator, an optional second dynamo-electric unit, and a clutch; a second drive system comprised of a second dynamo-electric unit essentially functioning as a motor; and a clutch to control the transmission status of the rotational kinetic energy between the first and the second drive systems. When the system is controlled to operate in the mode of a serial hybrid power train, the rotational kinetic energy from the engine drives the first dynamo-electric unit in the first drive system to operate as a generator and the clutch between the first and the second dynamo-electric units is disengaged. The power output from the first dynamo-electric unit drives the second dynamo-electric units of the first or the second drive system to operate as a motor for providing rotational kinetic energy to drive the load.

Under normal loading, the rotational kinetic energy output from the engine drives only the first drive system through the transmission, or drives only the second drive system through the control by the clutch, or drives the loads of the first and the second drive systems at the same time through the control by the clutch.

Depending on the operation requirement, an optional rechargeable energy storage device may be or may not be installed as part of the split serial-parallel hybrid dual-power drive system. If the rechargeable device is provided, the primary operation functions of the system includes that the power from the rechargeable device drives the first dynamo-electric unit in the first drive system to operate as a motor, or drives the second dynamo-electric unit in the second drive system to operate as a motor for providing the rotational kinetic energy to drive the load.

Under light loading, the rotational kinetic energy from the engine directly drive the load, the first dynamo-electric unit in the first drive system with any or all of the second dynamo-electric unit of the first or the second drive system commonly operates as a generator to output power to recharge the rechargeable device or to the other load that consumes electrical power.

Under normal loading, the rotational kinetic energy from the engine drives only the load of first drive system, or drives only the load of second drive system or drives the loads of the first and the second drive systems at the same time.

Under heavy loading, the power from the rechargeable device drives the first dynamo-electric unit in the first drive system with any or all of the second dynamo-electric unit of the first or the second drive system operates as a motor to jointly drive the load with the power from the engine to provide the operation of the parallel hybrid power train.

## 6

The basic system of the present invention includes the active rotational power source, frequently implemented by an internal combustion engine used to produce rotational kinetic energy to directly drive the load or, via the optional controllable clutch, or a transmission unit of multi-speed or continuously variable transmission function, or inverse shift function, or idling function or torque conversion function; while the rotational kinetic energy from the active rotational power source drives the first dynamo-electric unit to operate as a generator to complete the configuration of the first drive system.

Power generated by the first dynamo-electric unit drives the second dynamo-electric unit adapted to the first or the second drive system to operate as a motor for driving the load or providing power to other load that consumes electrical power.

The second dynamo-electric unit of the first drive system is an optionally adapted item which assisting drive the load of first drive system, the necessity of second dynamo-electric unit installation depends on system requirement.

The second drive system is comprised by second dynamo-electric unit as the power source to drive the load directly or through an optional transmission unit. An optional transmission or a clutch may be installed between the second drive system and the active rotational power source to control the transmit or disengagement of rotational kinetic between the second drive system and the active rotational power sources. An optional transmission unit or clutch may be installed at between a rotational part of the second dynamo-electric unit of the second drive system or a rotational mechanism driven by the second drive system, and a rotational part of the first or the second dynamo-electric unit in the first drive system or the rotational mechanism driven by the first drive system to control whether operation of coupled transmission of the rotational kinetic energy or separation operation without coupled transmission between the first and the second drive systems is required.

Under light loading, the operation of the split serial-parallel hybrid dual-power drive system could be controlled to perform serial or parallel hybrid power transmission. In the parallel transmission mode, the power from the active rotational power source may transmit to the load of first drive system for driving, or disengage from the load of first drive system.

Under the operation of serial hybrid power transmission, the active rotational power source may be regulated to coupled transmission or disengaged from the load driven by the first drive system by demand. In the status of disengaged from coupled transmission, the clutch disposed between the first and the second drive systems is disengaged while the engine as the active rotational power source provides the function of outputting the rotational kinetic energy subject to the control by manual or through a control system to drive the first dynamo-electric unit to operate as a generator, thus to further drive the second dynamo-electric unit in the first or the second drive system to operate as a motor to drive the load.

Under normal or a heavy loading, the system could be configured to parallel hybrid power transmission mode, the rotational kinetic energy from the engine to drive either or both loads of the first and the second drive systems. If an optional rechargeable device is installed, it could be incorporated to provide electrical energy to the first dynamo-electric unit of the first drive system or to the second dynamo-electric unit in the first or the second drive system functioning as a motor with the power of engine to jointly drive the load

during start-up or acceleration or other heavy loading situation; or directly drive the load under light loading or urban driving mode.

If an engine is implemented as the active rotational power source, the split serial-parallel hybrid dual-power drive system of the present invention essentially provides the following functions:

The rotational kinetic energy from the engine transmit through the transmission unit to drive the load of the first drive system, or to drive the load of second drive system, or the loads of both systems; and

When the system operates under serial hybrid power transmission mode, the rotational kinetic energy from the engine drives the load of the first drive system comprised of the transmission unit, the optional clutch, and the transmission unit with functions of multi-speed or continuously variable transmission, inverse, or idling shift, or torque conversion. With the rotational kinetic energy from the engine, the first dynamo-electric unit in the first drive system operates as a generator to drive the second dynamo-electric unit in the first or the second drive system to operate as a motor to drive the loads of first or second drive system or other loads demanding electrical power.

Under light loading, the split serial-parallel hybrid dual-power drive system could be manipulated to provide serial or parallel hybrid power transmission. Under parallel hybrid power transmission mode, the active rotational power source and the load of the first drive system may coupled in transmission state for load driving, or disengaged from the load of first drive system, splitting from the driving power of engine.

When the system operating in serial transmission mode, the clutch between the first and the second drive systems is disengaged, and the active rotational power source may coupled with or disengaged from the load of the first drive system. Meanwhile, the engine serving as the active rotational power source subject to the control by manual or by a control system drives the first dynamo-electric unit to operate as a generator drive the second dynamo-electric unit in the first or the second drive system to operate as a motor for driving the load.

When the system operating in the parallel power transmission mode, rotational kinetic energy from the engine drive the load directly or simultaneously drive the first dynamo-electric unit in the first drive system which operate as a generator to drive the second dynamo-electric units of the first or the second drive system to function as a motor for respectively load driving, or the power generated from the first dynamo-electric unit to drive any other electrical powered load.

If an optional rechargeable device is adapted with the system, the operating functions of the parallel hybrid power transmission include:

Power supplied from the rechargeable device drives the first dynamo-electric unit in the first drive system and any or all the second dynamo-electric unit in the first or the second drive system; or drives any dynamo-electric unit to operate as a motor for driving the load; or the first or the second dynamo-electric unit operates as a motor to output the rotational power jointly drive the load with power from the engine; or

Power supplied form the rechargeable device drives the first dynamo-electric unit in the first drive system and any or all of the second dynamo-electric unit in the first or the second drive system to operate as the motor for driving the load;

Kinetics from the engine drive the first dynamo-electric unit in the first drive system and any or all of the second dynamo-electric unit in the first or the second drive system to operate as a generator to recharge the rechargeable device or supply power to other electrical loading;

The load inversely drives the dynamo-electric unit in the first drive system and any or all the second dynamo-electric unit in the first or the second drive system to operate as a generator of power regeneration to recharge the rechargeable device or supply power to other electrical loading;

The mechanical damp of the engine functions as a brake drives, or together with the rechargeable device when provided, the dynamo-electric unit in the first drive system and any or all the second dynamo-electric unit in the first or the second drive system to operate as a generator of power regeneration to recharge the rechargeable device or supply power to other load that consumes power; and

The rechargeable device drives the dynamo-electric unit in the first drive system and any or all of the second dynamo-electric unit in the first or the second drive system to operate as an engine starting motor or to drive other mechanical loading.

Pressurized mixture of air and the fuel, or natural gas or other gases whether in the form of liquid fuel such as gasoline, diesel oil or other fuels including hydrogen currently in development fed to the internal combustion engine is given a brake specific fuel consumption depending on the load torque and rpm. For higher operating efficiency, whether the separation serial-parallel dual-power system operating in the serial or parallel hybrid power transmission mode, fuel saving and pollution reduction could be accomplished by setting the engine operation in optimal rpm range and operating conditions of higher energy efficiency. Both of the rpm range and optimal operation conditions to be set for the engine are maintained by the system operating under serial or parallel hybrid power transmission mode, the engine drives the first dynamo-electric unit to operate as a generator, and drives the second dynamo-electric unit to operate as a motor so to control the engine running within an rpm range of lower fuel consumption with a higher power output to operating inside the optimal brake specific fuel consumption region. When the optional rechargeable device is adapted to the system, the engine drives the first dynamo-electric unit in the first drive system to operate as a generator to recharge the rechargeable device, or the power from the rechargeable device and that from the first dynamo-electric unit in the first drive system jointly drive the second dynamo-electric unit in the first or the second drive system to operate as a motor to drive the load. The engine is controlled to run within specific range of rpm and operating conditions with higher energy efficiency. That is, when the system operates as a serial or parallel hybrid power transmission modes under light loading, the rotational kinetic energy from the engine drive the first dynamo-electric unit in the first drive system and any or all of the second dynamo-electric unit in the first or the second drive system to operate as a generator for charging the rechargeable device or supply power to other electrical loading.

By providing all or any part of those functions described above, the present invention refined the drawback of lower efficiency and higher pollution of the engine running at lower power output and lower rpm.

FIG. 1 shows a system block diagram of the present invention in a systematic configuration of the active rotational power source, the first and the second dynamo-electric units, an operational clutch and an optional transmission unit.

The split serial-parallel hybrid dual-power drive system illustrated in FIG. 1 is essentially comprised of sub units or device such as active rotational power source, dynamo-electrical units, transmission unit, transmission speed regulating unit, clutch, drive control unit, central control unit, recharge-

able device, or auxiliary rechargeable device, or power driven load, each element of present system described above with its specific function as follows:

The active rotational power source **100**: comprised of one or multiple internal combustion engine, external combustion engine, turbine engine, or any other physical effect generating rotational kinetic energy power source. The rotary part of the active rotational source may be directly coupled to the first dynamo-electric unit **101**, or coupled to the rotary part of the first dynamo-electric unit **101** through an optional transmission unit **[109] 109a**, a transmission unit **129**, or a clutch **102**.

The first dynamo-electric unit **101**: comprised of one or multiple rotary electrical machine providing functions as a generator, or one or multiple AC, brushless, brush, synchronous, or asynchronous rotary electrical machine that can be switched between the operation as a generator or a motor. When the second dynamo-electric unit **103** is adapted to the first drive system **1001**, the rotary part of the first dynamo-electric unit **101** is coupled to the second dynamo-electric unit **103** through the clutch **112** or a differential gear set or a planetary gear set; or through the clutch **112** and an optional transmission unit **[109] 109b**.

The second dynamo-electric unit **103**: comprised of one or multiple rotational motor providing functions of a rotary electrical machine, or one or multiple AC, brushless, brush, synchronous, or asynchronous rotary electrical machine that can be switched between the operation as a generator or a motor for providing power source to the second drive system **1002**; the output terminal of the rotation part of the second dynamo-electric unit **103** directly output the rotational kinetic energy to drive the load or through the clutch **122** or the optional transmission unit **[109] 109f**; if an optional clutch **132** is adapted to the system, the input end of the second dynamo-electric unit **103** is either directly or through the transmission unit, or the differential transmission unit **[109] 109f** coupled to the clutch **132**.

The clutch **102**: relates to a transmission unit operating by manual, mechanical force, eccentric force, pneumatic, or hydraulic force, or electromagnetic controlled clutch, or single way clutch, or torque adjustable coupler, or any other transmission device that engage or disengage the mechanical rotational kinetic energy. The clutch **102** is directly coupled or through the transmission unit **129** to coupled between the rotary part of the active rotational power source **100** and the first dynamo-electrical unit **101**. Depending on requirement, one or multiple or none clutch **102** may be provided.

The clutch **112**: an optional item relates to a transmission operating by manual, mechanical force, eccentric force, pneumatic, or hydraulic flow force, or electromagnetic controlled clutch, or single way clutch, or torque adjustable coupler, or any other transmission device that engage or disengage the mechanical rotational kinetic energy. The clutch **112** is coupled between the rotary part of the second dynamo-electric unit **103** and the output terminal of the active rotational power source **100**, or between the second dynamo-electric unit **103** and the first dynamo-electric unit **101**.

The clutch **122**: an optional item relates to a transmission operating by manual, mechanical force, eccentric force, pneumatic, or hydraulic flow force, or electromagnetic controlled clutch, or single way clutch, or torque adjustable coupler, or any other transmission device that engage or disengage the mechanical rotational kinetic

energy. The clutch **122** is coupled to where between the input end of the load **[120] 120b** and the rotary part of the second dynamo-electric unit **103**. One or multiple clutch **122** may be provided by demand. The function of the clutch **122** may be replaced with the idling function of the transmission device **[109] 109e** or a torque adjustable coupler connected to the input end of the load **[120] 120b**.

The Clutch **132**: an optional item relates to a transmission operating by manual, mechanical force, eccentric force, pneumatic, or hydraulic flow force, or electromagnetic controlled clutch, or single way clutch, or torque adjustable coupler, or any other transmission device that engage or disengage the mechanical rotational kinetic energy. The clutch **132** is coupled to where between the transmission unit **129** which connected to the rotary part of the active rotational power source **100** and the rotary part of the second dynamo-electrical unit **103** of the second drive system **1002**; or alternatively coupled between the rotary mechanism of a power train that produces or transmits the active rotational kinetic energy in the first drive system **1001** and the rotary mechanism that produces or transmits the active rotational function in the second drive system **1002** to control the transmission of rotational kinetic energy between the first and the second drive systems **1001**, **1002** to be transmitted or disengaged; while multiple second drive systems **1002** are adapted to the system, the clutch **132** is set for regulating the transmission or disconnect the rotational kinetic energy among the multiple second drive systems **1002**. One or multiple or no clutch **132** may be provided by demand.

The transmission unit **129**: comprise of an automatic, semi-automatic or manual multiple-speed or continuously variable transmission device or one at a fixed speed ratio, or a differential gear set, or a rotational gear set, a fluid torque coupler, or a belt continuously variable transmission (CVT) or any other transmission of the prior art that is provided with idling and reverse gear functions to be optionally coupled to the rotation part of the active rotational power source **100**; with the output terminal of the transmission unit **[120] 120a** to be either directly or through the transmission unit **[109] 109c** or the clutch **102** drive the first dynamo-electrical unit **101**, or the load **[120] 120a** of the first drive system **1001**; or is coupled to the input end of the clutch **132**. The transmission unit **129** may or may not be provided by requirement, and may be replaced with a planet gear set **801**, or a rotational gear set **1030**, or a dual acting dynamo-electric unit **1040**.

The transmission unit **[109] 109a**: an optional item comprised of an automatic, semi-automatic or manual multiple-speed or continuously variable transmission device or one at a fixed speed ratio, or a differential gear set, or a rotational gear set, a fluid torque coupler, or a belt continuously variable transmission (CVT) or any other transmission of the prior art that as required is coupled to where between the rotary part of the active rotational power source **100** and the clutch **102**, or at where between the clutch **102** and the rotary part of the first dynamo-electric unit **101**, or at where between the rotary parts respectively between the first dynamo-electrical unit **101**, and the clutch **112**, or at where between the rotary parts respectively of the clutch **112** and the second dynamo-electrical unit **103**, or at where between the rotary parts respectively between the second dynamo-electrical unit **103** and the clutch **122**, or at where

## 11

between the rotary parts respectively of the clutch **122** and the load **[120] 120b**. The transmission unit **[109] 109f** may or may not be installed depending on requirement.

The drive control unit **104**: an optional device comprised of an electro-mechanical or solid-state circuit provided for controlling the system operation under serial hybrid power transmission mode. While the first dynamo-electric unit **101** in the first drive system **1001** operating as a generator, the drive control unit **104** controls the power output to drive the second dynamo-electric unit **103** of the first or the second drive system **1001, 1002**, and/or recharge the rechargeable device **106**; or controls the power from the rechargeable device **106** to drive the first and the second dynamo-electric units **101, 103** each operating as a motor, or any of those dynamo-electrical units referred above for its operation variables such as driving voltage, amperage, polarity (in case of DC), frequency and phase (in case of AC) thus its rotating direction, rpm, torque and malfunction prevention. Alternatively, when the first dynamo-electric unit **101** in the first drive system **1001** and the second dynamo-electric unit **103** in the first or the second drive system **1001** or **1002**, or any part of those dynamo-electric units therein is inversely driven to operate as a generator, the drive control unit **104** is applied to regulate the recharging power transferred to the rechargeable device **106** or power supplied to other electrical loading for the dynamo-electric unit to operate for breaking function by regenerated power.

The central control unit **105**: an optional item comprised of solid-status or electro-mechanical device, or chip and related working software; processing the commanding signal from control interface **107** to control the split serial-parallel hybrid dual-power transmission system to operating in optimal fuel consumption and pollutant control, i.e., to regulating the system to operating in optimal brake specific fuel consumption region under either serial or parallel hybrid power transmission mode by having the engine to operate in a specific range of rpm which consumes less fuel yet yields higher power efficiency. The central control unit **105** sending command signals to the drive control unit **104** to control the operation of relative functions among the first dynamo-electric unit **101** in the first drive system **1001**, the second dynamo-electric unit **103** in the first or the second drive system **1001** or **1002**, and the rechargeable device **106**, and controls the feedback monitoring and interaction among various units in the system.

The rechargeable device **106**: an optional item implemented by various types of rechargeable batteries, super capacitors, or any other rechargeable device.

The control interface **107**: an optional item comprised of solid-state, or electro-mechanical device, or chip, and related working software to receive inputs by manual or by control signals to control the operation of the split serial-parallel dual-power system.

The auxiliary rechargeable device **110**: comprised of various types of rechargeable batteries, super capacitors, or flywheel storage, or any other rechargeable device with its power controlled by a startup switch **111** to drive a startup motor **121** adapted to the engine serving as the active rotational power source **100** thus to directly or through the transmission device **119**, or to supply power to its peripheral equipment or any other electrical power

## 12

driven load **130**. The auxiliary rechargeable device **110**, the startup switch **111** and the startup motor **121** are all optional items.

The power driven load **130**: an optional item provided as a peripheral load driven by the first dynamo-electric unit **101** or the second dynamo-electric unit **103** operating as a generator, or by the rechargeable device **106**, or the auxiliary rechargeable device **110** to output the rotational kinetic energy to drive land or surface transportation means or aircraft, and industrial equipment that requires to receive the input of rotational mechanical kinetics.

Given with an engine as the active rotational power source, the split serial-parallel hybrid dual-power drive system provides partial or all of the following functions:

The rotational kinetic energy from the engine power drives all or partial of the load **[120] 120a** adapted to the first drive system **1001** and/or the load **[120] 120b** adapted to the second drive system **1002**.

When the system is operating in serial hybrid power transmission mode, the engine is regulated to run from lower rpm up to higher rpm, or at a desired rpm to drive the first dynamo-electric unit **101** in the first drive system **1001** to function as a generator. If the system is not equipped with the rechargeable device **106**, the power generated from the first dynamo-electric unit **101** drives the second dynamo-electric unit **103** in the first drive system **1001** or the second drive system **1002** to operate as a motor for generating the rotational kinetic energy to drive the load **[120] 120b**. If the rechargeable device **106** is provided and under light loading, the power generated by the first dynamo-electric unit **101** in the first drive system **1001** drives the second dynamo-electric unit **103** in the first drive system **1001** or the second drive system **1002** and recharging the rechargeable device **106** simultaneously; under heavy loading, the power generated by the first dynamo-electric unit **101** in the first drive system **1001** and power from the rechargeable device **106** jointly drive the second dynamo-electric unit **103** adapted to the first drive system **1001** or to the second drive system **1002** for generating the rotational kinetic energy to drive the load **[120] 120b** and simultaneously governing the engine to run at desired rpm which yields higher energy efficiency for fuel consumption and pollution reduction. The definition of desired rpm mentioned above generally refers to the rpm range to achieve the optimal brake specific fuel consumption wherein the engine runs with lower fuel consumption but higher output power no matter the system is operating in a serial or parallel hybrid power transmission mode. When the rechargeable device **106** is provided, the power generated by the first dynamo-electric unit **101** driven by the engine recharges the rechargeable device **106**; or the power from the rechargeable device **106** and that from the first dynamo-electric unit **101** jointly drive the second dynamo-electric unit **103** to operate as a motor to drive the load **[120] 120b** for maintaining the engine to run at a desired rpm which yields higher energy efficiency. The definition of the desired rpm generally refers to the rpm range to achieve the optimal brake specific fuel consumption region wherein the engine runs at lower fuel consumption with relatively higher output power whether the system is operating in a serial or parallel hybrid power transmission mode.

When the optional rechargeable device **106** is provided and the system operating under parallel hybrid power transmission mode, the power from the rechargeable device



## 13

106 drives the first dynamo-electric unit 101 in the first drive system 1001 and/or the second dynamo-electric unit 103 in the first drive system 1001 or in the second drive system 1002 to operate as a motor to jointly drive the load [120] 120b with the engine. Under light loading condition, besides driving the load [120] 120b, the rotational kinetic energy from the engine simultaneously drive the first dynamo-electric unit 101, and the second dynamo-electric unit 103 in the first drive system 1001 or in the second drive system 1002 or any part of the second dynamo-electric unit 103 therein to recharge the rechargeable device 106 or supply power to other electrical power driven load 130. Under heavy loading, the power from the rechargeable device 106 drives the first dynamo-electric unit 101 in the first drive system 1001 and the second dynamo-electric unit 103 in the first drive system 1001 or in the second drive system 1002 or any part of the second dynamo-electric unit 103 therein for jointly driving the load with those rotational kinetic energy output from the engine.

The power from the rechargeable device 106 drives the first dynamo-electric unit 101 in the first drive system 1001, and the second dynamo-electric unit 103 in the first drive system 1001 or in the second drive system 1002 or any part of the second dynamo-electric unit 103 therein to operate as a generator for driving the load [120] 120b.

The first dynamo-electric unit 101 in the first drive system 1001, and the second dynamo-electric unit 103 in the first drive system 1001 or in the second drive system 1002 or any or part of the second dynamo-electric unit 103 therein is driven by the engine to operate as a generator for power regeneration to recharge the rechargeable device 106 or supply power to any other electrical loading 130.

The first dynamo-electric unit 101 in the first drive system 1001, and the second dynamo-electric unit 103 in the first drive system 1001 or in the second drive system 1002 or any part of the second dynamo-electric unit 103 therein is reversely driven by the load [120] 120b to operate as a generator for power regeneration to recharge the rechargeable device 106 or supply power to any other electrical load 130.

When the rechargeable device 106 is provided, the mechanical damping of the engine provides braking function, and the first dynamo-electric unit 101 in the first drive system 1001, and the second dynamo-electric unit 103 in the first drive system 1001 or in the second drive system 1002 or any part of the second dynamo-electric unit 103 therein operates as a generator to recharge the rechargeable device 106 or supply power to any other electrical-driven load 130.

The rechargeable device 106 drives the first dynamo-electric unit 101 in the first drive system 1001, and the second dynamo-electric unit 103 in the first drive system 1001 or in the second drive system 1002 or any part of the second dynamo-electric unit 103 therein to operate as a motor for engine starting up.

The clutch 132 is controlled to engage for transmitting the rotational kinetic energy between the transmission unit 129 and the second drive system 1002 coupled to the active rotational power source 100, or transmitting the rotational kinetic energy between the first drive system 1001 and the second drive system 1002, or transmitting the rotational kinetic energy between or among multiple second drive systems; and to cut off the transmission of rotational kinetic energy when disengaged.

## 14

FIGS. 2 through 39 are preferred embodiments of the present invention based on those sub systems and functions, and those preferred embodiment do not limit any other applications on the same principles. To simplify the description, the continuously variable transmission unit [109] 109a, the auxiliary rechargeable device 110, the startup switch 111, the startup motor 121, the central control unit 105, and the control interface 107 as illustrated in FIG. 1 are omitted while the engine functions as the active rotational power source 100 with the first dynamo-electric unit 101, the second dynamo-electric unit 103, clutches 102, 112, 122, and 132, the drive control unit 104 and the optional rechargeable device 106, the power drive load 130 are retained in those preferred embodiments illustrated in FIGS. 2 through 39 to drive the load [120] 120b.

FIGS. 2 through 51 are preferred embodiment of various drive systems based on the system as illustrated in FIG. 1 with each individual preferred embodiment provides all or partial of the following operating functions:

System Function 1: the optional rechargeable device 106 is not provided in the system and the system operates in serial hybrid power transmission mode. Whether the rotational kinetic energy from the active rotational drives the load [120] 120a through the first drive system 1001 or not, the system could be regulated by manual control, or by the control system comprised of the central control unit 105 and the drive control unit 104 to control the rotational kinetic energy from the active rotational power source 100 to drive the first dynamo-electric unit 101 to operate as a generator which further drives the second dynamo-electric unit 103 in the first drive system 1001 to operate as a motor for driving the load [120] 120a.

System Function 2: the optional rechargeable device 106 is not provided in the system and the system operates in serial hybrid power transmission mode. Whether the rotational kinetic energy from the active rotational drives the load [120] 120a through the first drive system 1001 or not, the system could be regulated by manual control, or by the control system comprised of the central control unit 105 and the drive control unit 104 to control the rotational kinetic energy from the active rotational power source 100 to drive the first dynamo-electric unit 101 to operate as a generator which further drives the second dynamo-electric unit 103 in the second drive system 1002 to operate as a motor for driving the load [120] 120b.

System Function 3: the optional rechargeable device 106 is not provided in the system and the system operates in serial hybrid power transmission mode. Whether the rotational kinetic energy from the active rotational drives the load [120] 120a through the first drive system 1001 or not, the system could be regulated by manual control, or by the control system comprised of the central control unit 105 and the drive control unit 104 to control the rotational kinetic energy from the active rotational power source 100 to drive the first dynamo-electric unit 101 to operate as a generator which further drives the second dynamo-electric unit 103 each provided in the first drive system 1001 and in the second drive system 1002 at the same time to operate as a motor for driving the load [120] 120b.

System Function 4: the optional rechargeable device 106 is provided in the system and the system operates in serial hybrid power transmission mode. Whether the rotational kinetic energy from the active rotational drives the load [120] 120a through the first drive system 1001 or not, the

15

system could be regulated by manual control, or by the control system comprised of the central control unit **105** and the drive control unit **104** to control the rotational kinetic energy from the active rotational power source **100** which further recharge the rechargeable device **106** or supply power to any other electrical power driven load **130** (including any externally connected unspecified load) and to drive the second dynamo-electric unit **103** in the first drive system **1001** (including any subunit such as the pilot drive unit **1000**) to operate as a motor for driving the load **[120] 120a**.

System Function 5: the optional rechargeable device **106** is provided in the system and the system operates in serial hybrid power transmission mode. Whether the rotational kinetic energy from the active rotational drives the load **[120] 120a** through the first drive system **1001** or not, the system could be regulated by manual control, or by the control system comprised of the central control unit **105** and the drive control unit **104** to control the rotational kinetic energy from the active rotational power source **100** to drive the first dynamo-electric unit **101** to operate as a generator which further recharge the rechargeable device **106** or supply power to any other electrical power driven load **130** (including any externally connected unspecified load) and to drive the second dynamo-electric unit **103** in the second drive system **1002** to operate as a motor for driving the load **[120] 120b**.

System Function 6: the optional rechargeable device **106** is provided in the system and the system operates in serial hybrid power transmission mode. Whether the rotational kinetic energy from the active rotational drives the load **[120] 120a** through the first drive system **1001** or not, the system could be regulated by manual control, or by the control system comprised of the central control unit **105** and the drive control unit **104** to control the rotational kinetic energy from the active rotational power source **100** to drive the first dynamo-electric unit **101** to operate as a generator to further recharge the rechargeable device **106** or supply power to any other electrical power driven load **130** (including any externally connected unspecified load) and to drive the second dynamo-electric unit **103** each in the first drive system **1001**, and in the second drive system **1002** to operate as a motor for driving the load **[120] 120b**.

System Function 7: the optional rechargeable device **106** is provided in the system and the system operates in serial hybrid power transmission mode. Whether the rotational kinetic energy from the active rotational drives the load **[120] 120a** through the first drive system **1001** or not, the system could be regulated by manual control, or by the control system comprised of the central control unit **105** and the drive control unit **104** to control the rotational kinetic energy from the active rotational power source **100** to drive the first dynamo-electric unit **101** to operate as a generator and that power from the rechargeable device **106** to jointly drive the second dynamo-electric unit **103** in the first drive system **1001** (including any subunit such as the pilot drive unit **1000**) to operate as a motor for driving the load **[120] 120a**.

System Function 8: the optional rechargeable device **106** is provided in the system and the system operates in serial hybrid power transmission mode. Whether the rotational kinetic energy from the active rotational drives the load **[120] 120a** through the first drive system **1001** or not, the system could be regulated by manual control, or by the control system comprised of the central control unit **105** and the drive control unit **104** to control the rotational

16

kinetic energy from the active rotational power source **100** to drive the first dynamo-electric unit **101** to operate as a generator, with the power from the rechargeable device **106** to jointly drive the second dynamo-electric unit **103** in the second drive system **1002** to operate as a motor for driving the load **[120] 120b**.

System Function 9: the optional rechargeable device **106** is provided in the system and the system operates in serial hybrid power transmission mode. Whether the rotational kinetic energy from the active rotational drives the load **[120] 120a** through the first drive system **1001** or not, the system could be regulated by manual control, or by the control system comprised of the central control unit **105** and the drive control unit **104** to control the rotational kinetic energy from the active rotational power source **100** to drive the first dynamo-electric unit **101** to operate as a generator and with the power from the rechargeable device **106** to jointly drive the second dynamo-electric unit **103** each in the first drive system **1001** and in the second drive system **1002** to operate as a motor for driving the load **[120] 120b**.

System Function 10: the rotational kinetic energy from the engine serves as the active rotational power source **100** drives the load **[120] 120a** of the first drive system **1001**.

System Function 11: the rotational kinetic energy from the engine serves as the active rotational power source **100** drives the load **[120] 120b** of the second drive system **1002**.

System Function 12: the rotational kinetic energy from the engine serves as the active rotational power source **100** simultaneously drives the load **[120] 120a** of the first drive system **1001** and the load **[120] 120b** of the second drive system **1002**.

System Function 13: the rotational kinetic energy from the engine serves as the active rotational power source **100** drives the load **[120] 120a** of the first drive system **1001**, and simultaneously drives the first dynamo-electric unit **101** to operate as a generator to recharge the rechargeable device **106** or supply power to any other electrical power driven load **130** (including any externally connected unspecified load).

System Function 14: the rotational kinetic energy from the engine serves as the active rotational power source **100** drives the load **[120] 120a** of the first drive system **1001**, and simultaneously drives the second dynamo-electric unit **103** in the first drive system **1001** or in the second drive system **1002** to operate as a generator to recharge the rechargeable device **106** or supply power to any other electrical power driven load **130** (including any externally connected unspecified load).

System Function 15: the rotational kinetic energy from the engine serves as the active rotational power source **100** drives the load **[120] 120a** of the first drive system **1001**, and drives the first dynamo-electric unit **101** to operate as a generator and simultaneously drives the second dynamo-electric unit **103** in the first drive system **1001** or in the second drive system **1002** to operate as a generator to recharge the rechargeable device **106** or supply power to any other electrical power driven load **130** (including any externally connected unspecified load).

System Function 16: the rotational kinetic energy from the engine serves as the active rotational power source **100** drives the load **[120] 120b** of the second drive system **1002**, and simultaneously drives the first dynamo-electric unit **101** to operate as a generator to recharge the rechargeable device **106** or supply power to any other



System Function 33: the power from the rechargeable device **106** drives the second dynamo-electric unit **103** in the first drive system **1001** and in the second drive system **1002** to function as a motor for jointly driving the load **[120]** *120a* and *120b* of the first drive system **1001** and the second system **1002** with the rotational kinetic energy from the active rotational power source **100**.

System Function 34: the power from the rechargeable device **106** drives the first dynamo-electric unit **101** to function as a motor for jointly driving the load **[120]** *120a* of the first drive system **1001** with the rotational kinetic energy from the active rotational power source **100**.

System Function 35: the power from the rechargeable device **106** drives the first dynamo-electric unit **101** to function as a motor for producing the rotational kinetic energy for jointly driving the load **[120]** *120b* of the second drive system **1002** with the power from the active rotational power source **100**.

System Function 36: the power from the rechargeable device **106** drives the first dynamo-electric unit **101** to function as a motor for jointly driving both loads **[120]** *120a*, *120b* of the first drive system **1001** and the second drive system **1002** with the rotational kinetic energy from the active rotational power source **100**.

System Function 37: the power from the rechargeable device **106** drives the first dynamo-electric unit **101** to function as a motor and simultaneously drives the second dynamo-electric unit **103** in the first drive system **1001** to operate as a motor for producing the rotational kinetic energy to jointly driving the load **[120]** *120a* of the first drive system **1001** with those from the active rotational power source **100**.

System Function 38: the power from the rechargeable device **106** drives the first dynamo-electric unit **101** to function as a motor and simultaneously drives the second dynamo-electric unit **103** in the second drive system **1002** to operate as a motor for producing the rotational kinetic energy to jointly driving the load **[120]** *120b* of the second drive system **1002** with the power from the active rotational power source **100**.

System Function 39: the power from the rechargeable device **106** drives the first dynamo-electric unit **101** to function as a motor and simultaneously drives the second dynamo-electric unit **103** in the first drive system **1001** or in the second drive system **1002** to operate as a motor for producing the rotational kinetic energy to jointly driving both loads **[120]** *120a*, *b* respectively of the first drive system **1001** and the second drive system **1002** with the power from the active rotational power source **100**.

System Function 40: the load **[120]** *120a* of the first drive system **1001** reversely drives the first dynamo-electric unit **101** to operate as a generator to recharge the rechargeable device **106** or supply power to other electrical power driven load **130** (including any externally connected unspecified load) to provide the function of dynamic feedback electrical power regeneration from braking.

System Function 41: the load **[120]** *120b* of the second drive system **1002** reversely drives the first dynamo-electric unit **101** to operate as a generator to recharge the rechargeable device **106** or supply power to other electrical power driven load **130** (including any externally connected unspecified load) to provide the function of dynamic feedback electrical power regeneration from braking.

System Function 42: both loads **[120]** *120a*, *b* respectively of the first drive system **1001** and the second drive system **1002** reversely drives the first dynamo-electric unit **101** to operate as a generator to recharge the rechargeable device **106** or supply power to other electrical power driven load **130** (including any externally connected unspecified load) to provide the function of dynamic feedback electrical power regeneration from braking.

System Function 43: the load **[120]** *120a* of the first drive system **1001** reversely drives the second dynamo-electric unit **103** of the first drive system **1001** to operate as a generator to recharge the rechargeable device **106** or supply power to other electrical power driven load **130** (including any externally connected unspecified load) to provide the function of dynamic feedback electrical power regeneration from braking.

System Function 44: the load **[120]** *120b* of the second drive system **1002** reversely drives the second dynamo-electric unit **103** of the second drive system **1002** to operate as a generator to recharge the rechargeable device **106** or supply power to other electrical power driven load **130** (including any externally connected unspecified load) to provide the function of dynamic feedback electrical power regeneration from braking.

System Function 45: both loads **[120]** *120a*, *b* of the first drive system **1001** and the second drive system **1002** reversely drives the first dynamo-electric unit **101** to operate as a generator, and both of the second dynamo-electric units **103** in the first drive system **1001** and the second drive system **1002** to operate as a generator to recharge the rechargeable device **106** or supply power to other electrical power driven load **130** (including any externally connected unspecified load) to provide the function of dynamic feedback electrical power regeneration from braking.

System Function 46: the load **[120]** *120a* of the first drive system **1001** reversely drives the first dynamo-electric unit **101** to operate as a generator, and inversely draws the second dynamo-electric unit **103** in the first drive system **1001** to operate as a generator to recharge the rechargeable device **106** or supply power to other electrical power driven load **130** (including any externally connected unspecified load) to provide the function of dynamic feedback electrical power regeneration from braking.

System Function 47: the load **[120]** *120b* of the second drive system **1002** reversely drives the first dynamo-electric unit **101** to operate as a generator, and inversely draws the second dynamo-electric unit **103** in the second drive system **1002** to operate as a generator to recharge the rechargeable device **106** or supply power to other electrical power driven load **130** (including any externally connected unspecified load) to provide the function of dynamic feedback electrical power regeneration from braking.

System Function 48: both loads **[120]** *120a*, *b* respectively of the first drive system **1001** and the second drive system **1002** reversely drives the first dynamo-electric unit **101** to operate as a generator, and inversely draw both second dynamo-electric units **103** in the first drive system **1001** and the second drive system **1002** to operate as a generator to recharge the rechargeable device **106** or supply power to other electrical power driven load **130** (including any externally connected unspecified load) to provide the function of dynamic feedback electrical power regeneration from braking.

System Function 49: the mechanical damping of the engine deployed as the active rotational power source **100** serves as the brake for the load **[120] 120a**.

System Function 50: the mechanical damping of the engine deployed as the active rotational power source **100** serves as the brake for the load **[120] 120a** of the first drive system **1001** simultaneously reverse drive the first dynamo-electric unit **101** to operate as a generator to recharge the rechargeable device **106** or supply power to other electrical power driven load **130** (including any externally connected unspecified load) to impose braking force on the load **[120] 120a** via the damping for power regeneration.

System Function 51: the mechanical damp of the engine deployed as the active rotational power source **100** to execute braking on the load **[120] 120b** of the second drive system **1002** simultaneously reverse drive the first dynamo-electric unit **101** to operate as a generator to recharge the rechargeable device **106** or supply power to other electrical power driven load **130** (including any externally connected unspecified load) to impose braking force on the load **[120] 120b** of the second drive system **1002** by the damping for power regeneration.

System Function 52: the mechanical damping of the engine deployed as the active rotational power source **100** to impose breaking force on both loads **[120] 120a, b** of the first drive system **1001** and the second drive system **1002** simultaneously reverse drive the first dynamo-electric unit **101** to operate as a generator to recharge the rechargeable device **106** or supply power to other electrical power driven load **130** (including any externally connected unspecified load) to impose braking force on both loads **[120] 120a, b** of the first drive system **1001** and the second drive system **1002** by the damping for power regeneration.

System Function 53: the mechanical damping of the engine deployed as the active rotational power source **100** impose breaking force on the load **[120] 120a** of the first drive system **1001** simultaneously reversely drive the second dynamo-electric unit **103** of the first drive system **1001** to operate as a generator to recharge the rechargeable device **106** or supply power to other electrical power driven load **130** (including any externally connected unspecified load) to impose braking force on the load **[120] 120a** of the first drive system **1001** by the damping for power regeneration.

System Function 54: the mechanical damping of the engine deployed as the active rotational power source **100** impose breaking force on the load **[120] 120b** of the second drive system **1002** simultaneously reversely drive the second dynamo-electric unit **103** of the second drive system **1002** to operate as a generator to recharge the rechargeable device **106** or supply power to other electrical power driven load **130** (including any externally connected unspecified load) to impose breaking force on the load **[120] 120b** of the second drive system **1002** by the damping for power regeneration.

System Function 55: the mechanical damping of the engine deployed as the active rotational power source **100** to impose breaking force on both loads **[120] 120a, b** of the first drive system **1001** and the second drive system **1002** simultaneously reversely drive both second dynamo-electric units **103** of the first drive system **1001** and the second drive system **1002** to operate as a generator to recharge the rechargeable device **106** or supply power to other electrical power driven load **130** (including any externally connected unspecified load) to impose break-

ing force on both loads **[120] 120a, b** respectively of the first drive system **1001** and the second drive system **1002** by the damping for power regeneration.

System Function 56: the mechanical damping of the engine which deployed as the active rotational power source **100** to impose breaking force on the load **[120] 120a** of the first drive system **1001** and simultaneously reversely drive the first dynamo-electric units **101** to operate as a generator and also reversely driving the second dynamo-electric unit **103** of the first drive system **1001** to operate as a generator to recharge the rechargeable device **106** or supply power to other electrical power driven load **130** (including any externally connected unspecified load) to impose the braking force on the load **[120] 120a** of the first drive system **1001** by the damping for power regeneration.

System Function 57: the mechanical damping of the engine which deployed as the active rotational power source **100** to impose breaking force on the load **[120] 120b** of the second drive system **1002** and simultaneously reversely drive the first dynamo-electric units **101** to operate as a generator and also reversely driving the second dynamo-electric unit **103** of the second drive system **1002** to operate as a generator to recharge the rechargeable device **106** or supply power to other electrical power driven load **130** (including any externally connected unspecified load) to impose breaking force on the load **[120] 120b** of the second drive system **1002** by the damping for power regeneration.

System Function 58: the mechanical damping of the engine which deployed as the active rotational power source **100** to impose breaking force on both loads **[120] 120a, b** of the first drive system **1001** and the second drive system **1002** and simultaneously reversely drive the first dynamo-electric units **101** to operate as a generator and also reversely driving the second dynamo-electric unit **103** of the second drive system **1002** to operate as a generator to recharge the rechargeable device **106** or supply power to other electrical power driven load **130** (including any externally connected unspecified load) to impose breaking force on both loads **[120] 120a, b** of the first drive system **1001** and the second drive system **1002** by the damping for power regeneration.

System Function 59: if the starting motor **121** is adapted to the active rotational power source **100**, the power from the rechargeable device **106** drives the starting motor **121** for engine starting up the engine which is deployed as the active rotational source **100**.

System Function 60: the power from the rechargeable device **106** drives the first dynamo-electrical unit **101** to operate as a motor to start up the engine which serving as the active rotational source **100**.

System Function 61: the power from the rechargeable device **106** drives the second dynamo-electrical unit **103** in the first drive system **1001** or in the second drive system **1002** to operate as a motor to start up the engine which serving as the active rotational source **100**.

System Function 62: the power from the rechargeable device **106** drives the first dynamo-electrical unit **101** and simultaneously driving the second dynamo-electrical unit **103** in the first drive system **1001** or in the second drive system **1002** to operate as a motor to start up the engine serving as the active rotational power source **100**.

System Function 63: the rotational kinetic energy from the engine serving as the active rotational power source **100** drives the first dynamo-electrical unit **101** to operate as a generator to recharge the rechargeable device **106** or

supply power to any other electrical power driven load **130** (including any externally connected unspecified load).

System Function 64: the rotational kinetic energy from the engine deployed as the active rotational power source **100** drives the second dynamo-electrical unit **103** in the first drive system **1001** or in the second drive system **1002** to operate as a generator, or simultaneously drives both of the second dynamo-electrical units **103** to recharge the rechargeable device **106** or supply power to any other electrical power driven load **130** (including any externally connected unspecified load).

System Function 65: the rotational kinetic energy from the engine deployed as the active rotational power source **100** drives the first dynamo-electrical unit **101** to operate as a generator and simultaneously driving the second dynamo-electrical unit **103** in the first drive system **1001** or in the second drive system **1002** to operate as a generator, or simultaneously drives both of the first and the second dynamo-electrical units **101**, **103** to recharge the rechargeable device **106** or supply power to any other electrical power driven load **130** (including any externally connected unspecified load).

System Function 66: the active rotational power source **100** drives the transmission unit **129** and the coupled clutch **1020** to drive the transmission unit **[109] 109c** which provides the regulating capability of variable transmission, reversing or idling functions to constitute the pilot drive unit **1000** for driving the load **[120] 120a**.

System Function 67: the active rotational power source **100** drives the transmission unit **129** and the coupled clutch **1020** to drive the transmission unit **[109] 109c** which provides the regulating capability of variable transmission, reversing or idling functions and multiple shafts which allow differential output to constitute the pilot drive unit **1000** for driving the load **120**.

System Function 68: while rechargeable device **106** is not provided, the active rotational power source **100** drives the independent power generation unit **2000** which further drive the second dynamo-electrical unit **103** in the first drive system **1001**, or drive the second dynamo-electrical unit **103** in the second drive system **1002**, or simultaneously drive both of the second dynamo-electrical units **103** respectively of the first drive system **1001** and the second drive system **1002** to operate as a motor for generating the rotational kinetic energy to drive the load **120**.

System Function 69: while rechargeable device **106** is provided, the active rotational power source **100** drives the independent power generation unit **2000** to further drive the second dynamo-electrical unit **103** in the first drive system **1001**, or drive the second dynamo-electrical unit **103** in the second drive system **1002**, or simultaneously drive both of the second dynamo-electrical units **103** respectively of the first drive system **1001** and the second drive system **1002** to operate as a motor for generating the rotational kinetic energy to drive the load **120**, and recharge the rechargeable device **106** or to supply power to any other electrical power driven load **130** (including any externally connected unspecified load).

System Function 70: while rechargeable device **106** is provided, the active rotational power source **100** drives the independent power generation unit **2000** to further drive the second dynamo-electrical unit **103** in the first drive system **1001**, or drive the second dynamo-electrical unit **103** in the second drive system **1002**, or simultaneously drive both of the second dynamo-electrical units **103**

respectively of the first drive system **1001** and the second drive system **1002** to operate as a motor for generating the rotational kinetic energy to drive the load **[120] 120b**.

System Function 71: while rechargeable device **106** is provided, the active rotational power source **100** drives the independent power generation unit **2000**; power from the power generation unit **2000** and the rechargeable device **106** jointly drive the second dynamo-electrical unit **103** in the first drive system **1001**, or jointly drive the second dynamo-electrical unit **103** in the second drive system **1002**, or jointly drive both of the second dynamo-electrical units **103** simultaneously respectively of the first drive system **1001** and the second drive system **1002** to operate as a motor for generating the rotational kinetic energy to drive the load **[120] 120b**.

System Function 72: while rechargeable device **106** is provided, the active rotational power source **100** drives the independent power generation unit **2000** to recharge the rechargeable device **106** or to supply power to any other electrical power driven load **130** (including any externally connected unspecified load).

System Function 73: while rechargeable device **106** is provided, the independent power generation unit **2000** is reversely driven by the loading to recharge the rechargeable device **106** or to supply power to any other electrical power driven load **130** (including any externally connected unspecified load) to impose breaking force on load **[120] 120b** by the damping for power regeneration.

System Function 74: while rechargeable device **106** is provided, and the power generation unit **2000** stops running, the power from the rechargeable device **106** drives the second dynamo-electrical unit **103** in the first drive system **1001**, or drives the second dynamo-electrical unit **103** in the second drive system **1002**, or simultaneously both second dynamo-electrical units **103** respectively of the first drive system **1001** and the second drive system **1002** to operate as a motor for generating the rotational kinetic energy to drive the load **[120] 120b**.

System Function 75: to permit the transmission of the rotational kinetic energy controlled by the clutch **132** between the first drive system **1001** and the second drive system **1002** while the clutch **132** is engaged.

System Function 76: to split the transmission of the rotational kinetic energy controlled by the clutch **132** between the first drive system **1001** and the second drive system **1002** while the clutch **132** is **[is]** disengaged.

System Function 77: to execute the transmission of the rotational kinetic energy controlled by clutch **132** between the transmission unit **129** coupled to the active rotational power source **100** and the second drive system **1002** while the clutch **132** is engaged.

System Function 78: to split the transmission of the rotational kinetic energy controlled by clutch **132** between the transmission unit **129** coupled to the active rotational power source **100** and the second drive system **1002** while the clutch **132** is disengaged.

System Function 79: to execute the transmission of the rotational kinetic energy controlled by clutch **132** between (among) multiple second drive systems **1002** while the clutch **132** is engaged.

System Function 80: to split the transmission of the rotational kinetic energy controlled by clutch **132** between (among) multiple second drive systems **1002** while the clutch **132** is disengaged.

## 25

Those preferred embodiments of the system as illustrated in FIG. 1 and FIGS. 2 through 51 to provide any or all of the functions described in System Functions 1 through 80.

FIG. 2 shows the block diagram of a first preferred embodiment of the split serial-parallel hybrid dual-power drive system of the present invention, essentially comprised of the first drive system 1001 and the second drive system 1002. In the first drive system 1001, the rotary part applied to output the rotational kinetic energy from the active rotational power source 100 is coupled to the optional transmission unit 129 and the optional clutch 102 to drive the first dynamo-electrical unit 101 and to further drive the respective load [120] 120a through the clutch 112 and the optional transmission unit [109] 109b. In the second drive system 1002, the second dynamo-electrical unit 103 served as the power source for the second drive system 1002 to drive the respective load [120] 120b through the optional clutch 122 and the optional transmission unit [109] 109e to comprise the second drive system 1002.

Accordingly, by regulating the operation of the first drive system 1001 and the second drive system 1002 constitutes the split serial-parallel hybrid dual-power drive system.

Furthermore, as required, the output terminal of the rotational kinetic energy of the active rotational power source 100, the output terminal of the transmission unit 129 coupled to, the rotary part to output the rotational kinetic energy of the clutch 102 coupled to, or the rotary part of the first dynamo-electrical unit 101 driven by the first drive system 1001 is coupled to the input end of the clutch 132; meanwhile the output terminal of the clutch 132 is coupled to the rotary part of the second dynamo-electrical unit 103 serving as the power source for the second drive system 1002, or the output terminal of the clutch 122 coupled to, the output terminal of the optional transmission unit [109] 109e coupled to, or the input terminal of the load [120] 120b driven by the second drive system 1002 for the control of the transmission status of the rotational kinetic energy between the first drive system 1001 and the second drive system 1002.

FIG. 3 shows the block diagram of a second preferred embodiment of the split serial-parallel hybrid dual-power drive system of the present invention, essentially comprised of the first drive system 1001 and the second drive system 1002. In the first drive system 1001, the rotary part applied to output the rotational kinetic energy from the active rotational power source 100 is coupled to the optional transmission unit 129 and the optional clutch 102 to drive the first dynamo-electrical unit 101 and to further drive the respective load [120] 120a through the clutch 112 and the optional transmission unit [109] 109b. In the second drive system 1002, the second dynamo-electrical unit 103 served as the power source for the second drive system 1002 drives the respective load [120] 120b through the optional transmission unit [109] 109e.

Accordingly, by regulating the operation of the first drive system 1001 and the second drive system 1002 constitutes the split serial-parallel hybrid dual-power drive system.

Furthermore, as required, the output terminal of the rotational kinetic energy of the active rotational power source 100, the output terminal of the transmission unit 129 coupled to, the rotary part to output the rotational kinetic energy of the clutch 102 coupled to, or the rotary part of the first dynamo-electrical unit 101 driven by the first drive system 1001 is coupled to the input terminal of the clutch 132; meanwhile the output terminal of the clutch 132 is coupled to the rotary part of the second dynamo-electrical unit 103 serving as the power source for the second drive system 1002, the output terminal of the optional transmission unit [109] 109e coupled to, or the

## 26

input terminal of the load [120] 120b driven by the second drive system 1002 for the control of the transmission status of the rotational kinetic energy between the first drive system 1001 and the second drive system 1002.

FIG. 4 shows the block diagram of the third preferred embodiment of the split serial-parallel hybrid dual-power drive system of the present invention, essentially comprised of the first drive system 1001 and the second drive system 1002. In the first drive system 1001, the rotary part applied to output the rotational kinetic energy from the active rotational power source 100 is coupled to the optional transmission unit 129 to drive the first dynamo-electrical unit 101 and to further drive the adapted load [120] 120a through the clutch 112 and the optional transmission unit [109] 109b. In the second drive system 1002, the second dynamo-electrical unit 103 serving as the power source for the second drive system 1002 drives the adapted load [120] 120b through the optional clutch 122 and optional transmission unit [109] 109e.

Accordingly, by regulating the operation of the first drive system 1001 and the second drive system 1002 constitutes the split serial-parallel hybrid dual-power drive system.

Furthermore, as required, the output terminal of the rotational kinetic energy of the active rotational power source 100, the output terminal of the transmission unit 129 coupled to, or the rotary part of the first dynamo-electrical unit 101 driven by the first drive system 1001 is coupled to the input terminal of the clutch 132; meanwhile the output terminal of the clutch 132 is coupled to the rotary part of the second dynamo-electrical unit 103 serving as the power source for the second drive system 1002, the output terminal of the clutch 122 coupled to, the output terminal of the optional transmission unit [109] 109e coupled to, or the input terminal of the load [120] 120b driven by the second drive system 1002 for the control of the transmission status of the rotational kinetic energy between the first drive system 1001 and the second drive system 1002.

FIG. 5 shows the block diagram of the fourth preferred embodiment of the split serial-parallel hybrid dual-power drive system of the present invention, essentially comprised of the first drive system 1001 and the second drive system 1002. In the first drive system 1001, the rotary part applied to output the rotational kinetic energy from the active rotational power source 100 is coupled to the optional transmission unit 129 to drive the first dynamo-electrical unit 101 and to further drive the respective load [120] 120a through the clutch 112 and the optional transmission unit [109] 109b. In the second drive system 1002, the second dynamo-electrical unit 103 serving as the power source for the second drive system 1002 drives the respective load [120] 120b through optional transmission unit [109] 109e.

Accordingly, by regulating the operation of the first drive system 1001 and the second drive system 1002 constitutes the split serial-parallel hybrid dual-power drive system.

Furthermore, as required, the output terminal of the rotational kinetic energy of the active rotational power source 100, the output terminal of the transmission unit 129 coupled to the active rotational power source 100, or the rotary part of the first dynamo-electrical unit 101 driven by the first drive system 1001 is coupled to the input terminal of the clutch 132; meanwhile the output terminal of the clutch 132 is coupled to the rotary part of the second dynamo-electrical unit 103 serving as the power source for the second drive system 1002, or the output terminal of the optional transmission unit [109] 109e, or the input terminal of the load [120] 120b driven by the second drive system 1002 for the control of the transmission status of the rotational kinetic energy between the first drive system 1001 and the second drive system 1002.

FIG. 6 shows the block diagram of the fifth preferred embodiment of the split serial-parallel hybrid dual-power drive system of the present invention, essentially comprised of the first drive system 1001 and the second drive system 1002. An independent power generation unit 2000 is comprised of the optional transmission unit [109] 109b and the optional clutch 102 provided either on the same side but not on the same shaft, not on the same side but on the same shaft, or neither on the same side nor on the same shaft of the output terminal of the load [120] 120a driven by the active rotational power source to be coupled to the first dynamo-electrical unit 101; and the rotary part of the active rotational power source 100 is coupled to the optional transmission unit 129, the optional clutch 112 and the optional transmission [109] 109c to drive the respective load [120] 120a to comprise the first drive system 1001. In the second drive system 1002, the second dynamo-electrical unit 103 serving as the power source for the second drive system 1002 drives the adapted load [120] 120b through the optional clutch 122 and optional transmission unit [109] 109e.

Accordingly, by regulating the operation of the first drive system 1001 and the second drive system 1002 constitutes the split serial-parallel hybrid dual-power drive system.

Furthermore, as required, the output terminal of the rotational kinetic energy of the active rotational power source 100, or the output terminal of the transmission unit 129 coupled to, or the rotary part to output the rotational kinetic energy of the clutch 112 coupled to, or the output terminal of the optional transmission unit [109] 109c provided to, or the rotary part of the first dynamo-electrical unit 101 driven by the first drive system 1001 is coupled to the input end of the clutch 132; meanwhile the output terminal of the clutch 132 is coupled to the rotary part of the second dynamo-electrical unit 103 serving as the power source for the second drive system 1002, the output terminal of the clutch 122 coupled to, the output terminal of the optional transmission unit [109] 109e provided to, or the input end of the load [120] 120b driven by the second drive system 1002 for the control of the transmission status of the rotational kinetic energy between the first drive system 1001 and the second drive system 1002.

FIG. 7 shows the block diagram of a sixth preferred embodiment of the split serial-parallel hybrid dual-power drive system of the present invention, essentially comprised of the first drive system 1001 and the second drive system 1002. In the first drive system 1001, the rotary part to output the rotational kinetic energy from the active rotational power source 100 is coupled to the optional transmission unit 129, the optional clutch 102, and the optional transmission unit [109] 109b to drive the first dynamo-electrical unit 101 and to further drive the adapted load [120] 120a through the non-coaxial-aligned transmission unit 129, the clutch 112, and the optional transmission unit [109] 109d. In the second drive system 1002, the second dynamo-electrical unit [103] 103a serving as the power source for the second drive system 1002 drives the respective load [120] 120b through the optional clutch 122 and optional transmission unit [109] 109e.

Accordingly, the control of the operation of the first drive system 1001 and the second drive system 1002 constitutes the split serial-parallel hybrid dual-power drive system.

Furthermore, as required, the output terminal of the rotational kinetic energy of the active rotational power source 100, the output terminal of the transmission unit 129 coupled to, the output terminal of the transmission unit 129 coupled to, or the rotary part to output the rotational kinetic energy of the clutch 102 coupled to, the output terminal of the transmission unit [109] 109b provided to, or the rotary part of the first dynamo-electrical unit 101 driven by the first drive system

1001 is coupled to the input end of the clutch 132; meanwhile the output terminal of the clutch 132 is coupled to the rotary part of the second dynamo-electrical unit [103] 103a serving as the power source for the second drive system 1002, the output terminal of the clutch 122 coupled to, the output terminal of the optional transmission unit [109] 109d provided to, or the input end of the load [120] 120a driven by the [second] first drive system [1002] 1001 for the control of the transmission status of the rotational kinetic energy between the first drive system 1001 and the second drive system 1002.

FIG. 8 shows the block diagram of the seventh preferred embodiment of the split serial-parallel hybrid dual-power drive system of the present invention, essentially comprised of the first drive system 1001 and the second drive system 1002. In the first drive system 1001, the rotary part applied to output the rotational kinetic energy from the active rotational power source 100 is coupled to the optional transmission unit 129, the optional clutch 102, and the transmission unit [109] 109b to drive the first dynamo-electrical unit 101 and to further drive the each respective load [120] 120a1, 120a2 by the rotary part of the first dynamo-electrical unit 101 through the transmission unit 129 to transmit the rotational kinetic energy to two or multiple clutches [112] 112a, 112b and transmission units [109] 109d1, 109d2 individually selected. Two or multiple second drive systems are comprised of multiple second dynamo-electrical unit [103] 103a, 103b serving as the power source for the second drive system 1002, and multiple clutches [122] 122a, 122b and multiple transmission units [109] 109e1, 109e2, 109f1, 109f2 individually selected to drive the adapted loads [120] 120e, 120f respectively.

Accordingly, the control of the operation of the first drive system 1001 and the second drive system 1002 constitutes the split serial-parallel hybrid dual-power drive system.

Furthermore, as required, the output terminal of the rotational kinetic energy of the active rotational power source 100, the output terminal of the transmission unit 129 coupled to, the rotary part to output the rotational kinetic energy of the clutch [102] 102a, 102b coupled to, the output terminal of the optional transmission unit [109] 109b1, 109b2 provided to, or the rotary part of the first dynamo-electrical unit [101] 101a, 101b driven by the first drive system 1001 is coupled to the input end of the transmission unit 129 operating on multi-shaft transmission; the output terminals of those clutches [132] 132a, 132b are respectively coupled to rotations parts of those multiple second dynamo-electrical units [103] 103b, 103c serving as the power source of the second drive system 1002, or respectively coupled to output terminals of those clutches [122] 122a, 122b, or coupled to output terminals of those transmission units [109] 109e1, 109e2, 109f1, 109f2 individually selected, or to input terminals of those loads respectively driven by the second drive system 1002 for the control of the transmission status of the rotational kinetic energy between the first drive system 1001 and the second drive system 1002.

FIG. 9 shows the block diagram of the eighth preferred embodiment of the split serial-parallel hybrid dual-power drive system of the present invention, essentially comprised of multiple first drive systems 1001 and multiple second drive systems 1002. In the first drive system 1001, the rotary part to output the rotational kinetic energy from the active rotational power source 100 is coupled to the optional transmission unit 129 provided with multiple output shafts respectively coupled to two or multiple optional clutches [102] 102a, 102b and transmission units [109] 109b1, 109b2 to drive two or multiple first dynamo-electrical units [101] 101a, 101b, two or multiple clutches [112] 112a, 112b, and two or multiple transmission units [109] 109c1, 109c2 to respectively drive



the adapted loads [120] 120a1, 120a2 through the respective clutch [112] 112a, 112b and the optional transmission unit [109] 109d1, 109d2. In the second drive system 1002, [two] two or multiple second dynamo-electrical units [103] 103b, 103c serving as the power source for the second drive system 1002 respectively drive multiple adapted load [120] 120b1, 120b2 through multiple optional clutches [122] 122a, 122b and multiple optional transmission units [109] 109e1, 109e2, 109f1, 109f2.

Accordingly, the control of the operation of the first drive system 1001 and the second drive system 1002 constitutes the split serial-parallel hybrid dual-power drive system.

Furthermore, as required, the output terminal of the rotational kinetic energy of the active rotational power source 100, the output terminal of the transmission unit 129 coupled to, or the rotary part of individual output of the transmission unit 109 operating on multi-shaft transmission coupled to, or the rotary parts to output the rotational kinetic energy of the clutches [102] 102a, 102b respectively coupled to, each output end of the optional transmission units [109] 109b1, 109b2, or each rotary part of the first dynamo-electrical units 101 driven by the first drive system 1001 is coupled to the input end of the clutch [132] 132a, 132b; meanwhile the output terminal of the clutch [132] 132a, 132b is coupled to each rotary part of the second dynamo-electrical units [103] 103b, 103c serving as the power source for the second drive system 1002, each output end of the clutches [122] 122a, 122b coupled to, each [output] input end of the optional transmission units [109] 109f1, 109f2 coupled to, or each input end of the loads [120] 120b1, 120b2 driven by the second drive system 1002 for the control of the transmission status of the rotational kinetic energy between the first drive system 1001 and the second drive system 1002.

FIG. 10 shows the block diagram of the ninth preferred embodiment of the split serial-parallel hybrid dual-power drive system of the present invention, essentially comprised of the first drive system 1001 and the second drive system 1002. In the first drive system 1001, the rotary part applied to output the rotational kinetic energy from the active rotational power source 100 is coupled to the optional transmission unit 129, the optional clutch 102, and the transmission unit 109 to drive the first dynamo-electrical unit 101 and to further drive those loads [120] 120a1, 120a2 adapted to both output terminals of the differential transmission unit [109] 109d through the optional transmission unit [109] 109c, the clutch 112 and the differential transmission unit [109] 109d. In the second drive system 1002, two or multiple second dynamo-electrical units [103] 103b, 103c serving as the power source for the second drive system 1002 respectively drive multiple adapted load [120] 120b1, 120b2 through each optional transmission units [109] 109f1, 109f2.

Accordingly, the control of the operation of the first drive system 1001 and the second drive system 1002 constitutes the split serial-parallel hybrid dual-power drive system.

Furthermore, as required, the output terminal of the rotational kinetic energy of the active rotational power source 100, the output terminal of the transmission unit 129 coupled to, the rotary part to output the rotational kinetic energy of the clutch 102 coupled to, the rotary part to output the rotational kinetic energy of the clutch 102 coupled to, the output terminal of the optional transmission unit [109] 109b provided to, or the rotary part of the first dynamo-electrical unit 101 driven by the first drive system 1001 is coupled to the input end of the clutch 132; meanwhile the output terminal of the clutch 132 is coupled to the input end of the differential transmission unit [109] 109e. Both output ends of the differential transmission unit [109] 109e are respectively coupled to both rotary parts

of the second dynamo-electrical units [103] 103b, 103c serving as the power source for the second drive system 1002 for the control of the transmission status of the rotational kinetic energy between the first drive system 1001 and the second drive system 1002.

FIG. 11 shows the block diagram of the tenth preferred embodiment of the split serial-parallel hybrid dual-power drive system of the present invention, essentially comprised of the first drive system 1001 and the second drive system 1002. In the first drive system 1001, the rotary part to output the rotational kinetic energy from the active rotational power source 100 is coupled to the optional transmission unit 129, the optional clutch 102, and the transmission unit [109] 109b to drive the first dynamo-electrical unit 101 and the rotary part of the first dynamo-electrical unit 101 is coupled to the optional transmission unit [109] 109c and the clutch 112 to drive two loads [120] 120a1, 120a2 respectively adapted to both output terminals of the differential transmission unit [109] 109d. In the second drive system 1002, multiple second dynamo-electrical units 103 serving as the power source for the second drive system 1002 respectively drive multiple loads [120] 120b1, 120b2 adapted to both output terminals of the differential transmission unit [109] 109f through the optional transmission unit [109] 109e, the clutch 122, and the differential transmission unit [109] 109f.

Accordingly, the control of the operation of the first drive system 1001 and the second drive system 1002 constitutes the split serial-parallel hybrid dual-power drive system.

Furthermore, as required, the output terminal of the rotational kinetic energy of the active rotational power source 100, the output terminal of the transmission unit 129 coupled to, the rotary part to output the rotational kinetic energy of the clutch 102 coupled to, the input end of the optional transmission unit [109] 109b, or the rotary part of the first dynamo-electrical unit 101 driven by the first drive system 1001 is coupled to the input end of the clutch 132; meanwhile the output terminal of the clutch 132 is coupled to the rotary part of the second dynamo-electrical unit 103 serving as the power source for the second drive system 1002, or the output terminal of the optional transmission unit [109] 109e, the output terminal of the clutch 122 coupled to the second drive system 1002, or to the input end of the differential transmission unit [109] 109f located at where between the clutch 122 and the driven load [120] 120b1, 120b2 for the control of the transmission status of the rotational kinetic energy between the first drive system 1001 and the second drive system 1002.

FIG. 12 shows the block diagram of the eleventh preferred embodiment of the split serial-parallel hybrid dual-power drive system of the present invention, essentially comprised of the first drive system 1001 and the second drive system 1002. In the first drive system 1001, the rotary part to output the rotational kinetic energy from the active rotational power source 100 is coupled to the optional transmission unit 129, the optional clutch 102, and the transmission unit [109] 109b to drive the first dynamo-electrical unit 101 and the rotary part of the first dynamo-electrical unit 101 is coupled to the optional transmission unit [109] 109c and the clutch 112, and further coupled to the optional transmission unit 129 provided with multiple input and output terminals. The transmission unit 129 provided with multiple input and output terminals is coupled to an auxiliary dynamo-electrical unit 1010 for the optional transmission unit [109] 109e coupled through the clutch 122 to drive the adapted load [120] 120a. In the second drive system 1002, the second dynamo-electrical unit 103 serving as the power source for the second drive system 1002 drives the adapted load [120] 120b through the operational transmission unit 109.

Accordingly, the control of the operation of the first drive system **1001** and the second drive system **1002** constitutes the split serial-parallel hybrid dual-power drive system.

Furthermore, as required, the output terminal of the rotational kinetic energy of the active rotational power source **100**, the output terminal of the transmission unit **[129] 129b** coupled to, the rotary part to output the rotational kinetic energy of the clutch **102** coupled to, the input end of the optional transmission unit **[109] 109b** provided to or the rotary part of the first dynamo-electrical unit **101** driven by the first drive system **1001** is coupled to the input end of the clutch **132**; meanwhile the output terminal of the clutch **132** is coupled to the rotary part of the second dynamo-electrical unit **103** serving as the power source for the second drive system **1002**, or the output terminal of the optional transmission unit **109** provided to, or the input end of the load **[120] 120b** driven by the second drive system **1002** for the control of the transmission status of the rotational kinetic energy between the first drive system **1001** and the second drive system **1002**.

FIG. **13** shows the block diagram of the twelfth preferred embodiment of the split serial-parallel hybrid dual-power drive system of the present invention, essentially comprised of the first drive system **1001** and the second drive system **1002**. In the first drive system **1001**, the rotary part to output the rotational kinetic energy from the active rotational power source **100** is coupled to the optional transmission unit **[129] 129a**, the optional clutch **102**, and the transmission unit **[109] 109b** to drive the first dynamo-electrical unit **101** and the rotary part of the first dynamo-electrical unit **101** is coupled to the optional transmission unit **[109] 109c** and the clutch **112**, and further to the optional transmission unit **[129] 129b** provided with multiple input and output terminals. The transmission unit **[129] 129b** provided with multiple input and output terminals is coupled to the auxiliary dynamo-electrical unit **1010** for the differential transmission unit **[109] 109d** coupled through the clutch **122**, and both output terminals of the differential transmission unit **[109] 109d** drive their respectively adapted loads **[120] 120a1 and 120a2**. In the second drive system **1002**, two or multiple second dynamo-electrical unit **103** serving as the power source for the second drive system **1002** drives the respectively adapted loads **[120] 120b1 and 120b2** through the respective operational transmission units **[109] 109f1, 109f2**.

Accordingly, the control of the operation of the first drive system **1001** and the second drive system **1002** constitutes the split serial-parallel hybrid dual-power drive system.

Furthermore, as required, the output terminal of the rotational kinetic energy of the active rotational power source **100**, the output terminal of the transmission unit **[129] 129a** coupled to, the rotary part to output the rotational kinetic energy of the clutch **102** coupled to, the input end of the optional transmission unit **[109] 109b** provided to or the rotary part of the first dynamo-electrical unit **101** driven by the first drive system **1001** is coupled to the input end of the clutch **132**; meanwhile the output terminal of the clutch **132** is coupled to the input end of the differential transmission unit **[109] 109e**, and both output ends of the differential transmission unit **[109] 109e** are respectively coupled to both rotary parts of the second dynamo-electrical units **[103] 103b, 103c** serving as the power source for the second drive system **1002** for the control of the transmission status of the rotational kinetic energy between the first drive system **1001** and the second drive system **1002**.

FIG. **14** shows the block diagram of the thirteenth preferred embodiment of the split serial-parallel hybrid dual-power drive system of the present invention, essentially comprised

of the first drive system **1001** and the second drive system **1002**. In the first drive system **1001**, the power generation unit **2000** is comprised of making the output terminal of the rotational kinetic energy of the active rotational power source **100** in the configuration of multiple output terminals either on the same side but not on the same shaft, not on the same side but on the same shaft, or neither on the same side nor on the same shaft for coupling with the optional transmission unit **129** and the optional clutch **102** to further couple to the first dynamo-electrical unit **101**; and one of the multiple output terminals of the rotational kinetic energy from the active rotational power source **100** is coupled to the optional transmission unit **129**, the optional clutch **112** and the optional transmission unit **[109] 109b** to drive the adapted load **[120] 120a** with the power generation unit **2000** to jointly constitute the first drive system **1001**. In the second drive system, the second dynamo-electrical unit **103** serving as the power source for the second drive system **1002** drives the adapted load **[120] 120b1, 120b2** through the optional clutch **122** and the optional transmission unit **[109] 109e, 109f**.

Accordingly, the control of the operation of the first drive system **1001** and the second drive system **1002** constitutes the split serial-parallel hybrid dual-power drive system.

Furthermore, as required, the output terminal of the rotational kinetic energy of the active rotational power source **100**, the output terminal of the transmission unit **129** coupled to, the rotary part to output the rotational kinetic energy of the clutch **112** coupled to, the output terminal of the optional transmission unit **[109] 109b** provided to the first drive system **1001**, or the input end of the driven load **[120] 120a** is coupled to the input end of the clutch **132**; meanwhile the output terminal of the clutch **132** is coupled to the rotary part of the second dynamo-electrical unit **103** serving as the power source for the second drive system **1002**, or the output terminal of the clutch **122** coupled to, or the output terminal of the optional transmission unit **[109] 109f** provided to, or the input end of the load **[120] 120b** driven by the second drive system **1002** for the control of the transmission status of the rotational kinetic energy between the first drive system **1001** and the second drive system **1002**.

FIG. **15** shows the block diagram of the fourteenth preferred embodiment of the split serial-parallel hybrid dual-power drive system of the present invention, essentially comprised of the first drive system **1001** and the second drive system **1002**. In the first drive system **1001**, the power generation unit **2000** is comprised of making the output terminal of the rotational kinetic energy of the active rotational power source **100** in the configuration of multiple output terminals either on the same side but not on the same shaft, not on the same side but on the same shaft, or neither on the same side nor on the same shaft for coupling with the optional transmission unit **129** and the optional clutch **102** to further couple to the first dynamo-electrical unit **101**; and one of the output terminals of the rotational kinetic energy from the active rotational power source **100** is coupled to the optional transmission unit **129**, the optional clutch **112** and the optional differential transmission unit **[109] 109b** to respectively drive two loads **[120] 120a1 and 120a2** adapted to both output terminals of the differential transmission unit **[109] 109b** with the power generation unit **2000** to jointly constitute the first drive system **1001**. In the second drive system **1002**, two or multiple second dynamo-electrical units **[103] 103b, 103c** serving as the power source for the second drive system **1002** respectively drive the adapted loads **[120] 120b1 and 120b2** through the optional transmission units **[109] 109e, 109f1 and 109f2**. By switching the clutch **132** to engage or disengage status to regulate the transmission of the rotational kinetic

energy between the first drive system **1001** and the second drive system **1002** are regulated to perform those functions described in System Functions 1 through 80.

Furthermore, as required, the output terminal of the rotational kinetic energy of the active rotational power source **100**, the output terminal of the transmission unit **129** coupled to, the rotary part to output the rotational kinetic energy of the clutch **112** coupled to the first drive system **1001**, or the output terminal of the differential transmission unit **[109] 109b** is coupled to the input end of the clutch **132**; meanwhile the output terminal of the clutch **132** is coupled to the input end of the differential transmission unit **[109] 109e** provided in the second drive system **1002** to respectively drive two rotary parts of both second dynamo-electrical units **[103] 103b and 103c** serving as the power source for the second drive system **1002** for the control of the transmission status of the rotational kinetic energy between the first drive system **1001** and the second drive system **1002**.

FIGS. **16** and **17** respectively illustrate the block diagrams of a fifteenth and a sixteenth preferred embodiments of the split serial-parallel hybrid dual-power drive system of the present invention. In both preferred embodiments, each is essentially comprised of the first drive system **1001** and the second drive system **1002**. In the first drive system **1001**, the rotary part applied to output the rotational kinetic energy of the active rotational power source **100** is coupled to the optional transmission unit **129** and further coupled to the planet gear **803** of the planetary gear set **801**. The rotary part of the first dynamo-electrical unit **101** is coupled to the sun gear **802** of the planetary gear set **801** while the relative motion between the rotary part and the stationary part of the first dynamo-electrical unit **101** is controlled by the drive control unit **104** to operate as a motor to output the rotational kinetic energy or as a generator to produce damping while generating power, with the effect of damping to transfer the rotational kinetic energy from the active rotational power source **100** to the external gear **804**; or alternatively, by the regulating of the drive control unit **104**, the stationary part and the rotary part are locked by electromagnetic force, the function of electromagnetic lock could be altered by the optional brake **902** with the rotary part of the first dynamo-electrical unit **101** coupled to the rotary part of the brake **902** and the stationary side of the brake **902** locked to the vehicle frame or the stationary part of the first dynamo-electrical unit **101**; accordingly, the first dynamo-electrical unit **101** is in locked status allowing the rotational kinetic energy from the active rotational power source **100** transferred to the external gear **804**.

Furthermore, the brake **901** is required for the active rotational power source **100** to drive the first dynamo-electrical unit **101** to operate as a generator. The external gear **804** of the planetary gear set **801** coupled to the input end of the clutch **112** and the rotary part of the brake **901**; the stationary part of the brake **901** is locked to the frame; and the other terminal of the clutch **112** might directly output to drive the load **[120] 120a** or through the optional transmission unit **[109] 109c** as illustrated in FIG. **16** or the other terminal of the clutch **112** might be coupled to the input terminal of the differential transmission unit **[109] 109c** as illustrated in FIG. **17**. Both differential output terminals of the differential transmission unit **[109] 109c** are provided to drive their respective loads **[120] 120a1 and 120a2** to constitute the first drive system **1001**.

The first drive system **1001** may or may not be provided with the second dynamo-electrical unit **[103] 103a** depending on requirement. While the second dynamo-electrical unit **[103] 103a** is provided to the first drive system **1001**, the

second dynamo-electrical unit **[103] 103a** illustrated in FIG. **16** may be coupled directly or through the optional transmission unit **[109] 109c** to the load **[120] 120a**; or coupled to the input terminal of the differential transmission unit **[109] 109c** driven by the clutch **112**, the clutch **112** as illustrated in FIG. **17**. Wherein, the clutch **112** and the brake **901** may be separately provided or arranged in common structure.

The second drive system **1002** adapt the second dynamo-electrical unit **[103] 103b** as the power source to couple to the optional transmission unit **[109] 109e** or any other transmission device for driving one or multiple load **[120] 120b or 120b1 and 120b2**, or as required, the rotary part of the second dynamo-electrical unit **[103] 103b** is coupled to the input terminal of the differential transmission unit **[109] 109e**, and both differential output terminals of the differential transmission unit **[109] 109e** are provided to drive respectively adapted loads **[120] 120b1 and 120b2** to constitute the second drive system **1002**. By switching the clutch **132** to engage or disengage status for regulating the transmission of the rotational kinetic energy between the first drive system **1001** and the second drive system **1002** makes the system to perform those functions described in System Functions 1 through 80.

The primary functions of the preferred embodiments illustrated in FIGS. **16** and **17** include that while the brake **901** is closed and the clutch **112** is disengaged, the external gear **804** is locked to make the active rotational power source **100** to solely drive the sun gear **802** through the planet gear **803** thus to drive the first dynamo-electrical unit **101** to operate as a generator for driving the second dynamo-electrical unit **103** optionally adapted to the first drive system **1001**, or for driving the second dynamo-electrical unit **103** adapted to the second drive system **1002**, or driving both second dynamo-electrical units **[103] 103a and 103b** adapted to the first drive system **1001** and the second drive system **1002** to provide the capability of generating the serial hybrid power output and/or recharge the rechargeable device **106**.

Alternatively, the power generated from the first dynamo-electrical unit **101** and the rechargeable device **106** jointly drive the second dynamo-electrical unit **[103] 103a** in the first drive system **1001**, or the second dynamo-electrical unit **[103] 103b** in the second drive system **1002** or both of the second dynamo-electrical units **103** simultaneously.

The second dynamo-electrical unit **[103] 103a and 103b** in the first drive system **1001** and in the second drive system **1002** drive the load **[120] 120a1, 120a2, 120b1 and 120b2** jointly by utilizing the rotational kinetic energy from the active rotational power source **100** with the power from the rechargeable device **106** when the clutch **112** is engaged.

When the clutch **112** is disengaged and the first dynamo-electrical unit **101** driven by the active rotational power source **100** operates as a generator, under the control of the drive control unit **104** the second dynamo-electrical unit **[103] 103a and 103b** operates in the serial hybrid power transmission mode by utilizing the power generated from the first dynamo-electrical unit **101**.

Alternatively, the power from the rechargeable device **106** regulated by the drive control unit **104** solely drives the second dynamo-electrical unit **[103] 103a and 103b** to operate as a motor; or the power generated from the first dynamo-electrical unit **101** and that from the rechargeable device **106** jointly drive the second dynamo-electrical unit **[103] 103a and 103b** to operate as a motor under the control of the drive control unit **104**.

Furthermore, the regenerated power of feedback braking regeneration provided by the second dynamo-electrical unit **[103] 103a and 103b** recharges the rechargeable device **106** or supply power to other electrical power driven load.

The operation between the rotary part of the optionally adapted second dynamo-electrical unit [103] 103a of the first drive system 1001 and the load [120] 120a may either directly or through the optional transmission unit 109 or other transmission device to drive one or multiple load [120] 120a1 and 120a2; or as required, the rotary part of the second dynamo-electrical unit 103 is coupled to the input end of the differential transmission unit [109] 109c for both differential output ends of the differential transmission unit [109] 109c to drive their respectively adapted loads [120] 120a1 and 120a2. Accordingly, the adapted load [120] 120a is driven by the structure and operation of the first drive system 1001 as described above.

In addition, the rotational kinetic energy output terminal of the active rotational power source 100 in the first drive system 1001, or the output terminal of the transmission unit 129 coupled to the power source 100 is coupled to the input terminal of the clutch 132. The output terminal of the clutch 132 is coupled to the rotary part of the second dynamo-electrical unit [103] 103b serving as the power source for the second drive system 1002, or to the output terminal of the optional transmission unit [109] 109d coupled to the second drive system 1002 as illustrated in FIG. 16; or coupled to the rotary part of the second dynamo-electrical unit [103] 103b serving as the power source for the second drive system 1002 as illustrated in FIG. 17, or to the input terminal of the differential transmission unit [109] 109e of multiple loads [120] 120b1 and 120b2 optionally adapted to the second drive system 1002 for the control of the transmission status of the rotational kinetic energy between the first drive system 1001 and the second drive system 1002.

FIG. 18 shows a block diagram of the seventeenth preferred embodiment of the split serial-parallel hybrid dual-power drive system of the present invention. The preferred embodiment is comprised of the first drive system 1001 and the second drive system 1002. In the first drive system 1001, the rotary part applied to output the rotational kinetic energy from the active rotational power source 100 is coupled to the optional transmission unit 129 and the planet gear 803 of the planetary gear set 801; and the rotary part of the first dynamo-electrical unit 101 is coupled to the sun gear 802 of the planetary gear set 801. Under the regulation of the drive control unit 104, the operation between the rotary part and the stationary part of the first dynamo-electrical unit 101 could optionally providing the functions as a motor to output the rotational kinetic energy, or to operate as a generator to produce damping while generating power output, with the effect of the damping, the rotational kinetic energy from the active rotational power source 100 is routed to the external gear 804. Alternatively, with the regulation of the drive control unit 104, the relative motion between the stationary part and the rotary part of the first dynamo-electrical unit 101 is locked by electromagnetic force. As required, the electromagnetic lockup function may be replaced by the dynamic brake 902 with the rotary part of the first dynamo-electrical unit 101 coupled to the rotary part of the brake 902 and the stationary part of the brake 902 is locked to the frame or to the stationary part of the first dynamo-electrical unit 101. Accordingly, the first dynamo-electrical unit 101 is locked up, which makes the rotational kinetic energy from the active rotational power source 100 to be routed through the external gear 804.

The brake 901 is required for the active rotational power source 100 to drive the first dynamo-electrical unit 101 to operate as a generator. The external gear 804 of the planetary gear set 801 is coupled to the input terminal of the clutch 112 and coupled to the rotary part of the brake 901; the stationary part of the brake 901 is locked to the frame; and the other

terminal of the clutch 112 may directly drive the load [120] 120a1 and 120a2 or through the optional transmission unit [109] 109c.

The first drive system 1001 may or may not be provided with the second dynamo-electrical unit [103] 103a. If the second dynamo-electrical unit [103] 103a is provided to the first drive system 1001, the second dynamo-electrical unit [103] 103a may be coupled to the load [120] 120a1 and 120a2 directly or through the optional transmission unit [109] 109c; or coupled to the input terminal of the differential transmission unit [109] 109c driven by the clutch 112, the clutch 112 as illustrated in FIG. 17. Wherein, the clutch 112 and the brake 901 may be separately provided or arranged in common structure.

The second drive system 1002 equipped with multiple second dynamo-electrical units 103 as the power source to respectively coupled to the optional transmission unit 109 or any other transmission device to drive respectively adapted loads [120] 120b1 and 120b2 to constitute the second drive system 1002.

Alternatively, by switching the clutch 132 to engage or disengage status for regulating the transmission of the rotational kinetic energy between the first drive system 1001 and the second drive system 1002 makes the system to perform those functions described in System Functions 1 through 80.

The primary operation functions of the preferred embodiments illustrated in FIG. 18 include that when the brake 901 is closed and the clutch 112 is disengaged, the external gear 804 is locked to make the active rotational power source 100 to solely drive the sun gear 802 through the planet gear 803 thus to drive the first dynamo-electrical unit 101 to operate as a generator for driving the second dynamo-electrical unit [103] 103a optionally adapted to the first drive system 1001, or for driving the second dynamo-electrical unit [103] 103b adapted to the second drive system 1002, or driving both second dynamo-electrical units [103] 103a and 103b adapted to the first drive system 1001 and the second drive system 1002 to provide the capability of generating the serial hybrid power output and/or recharge the rechargeable device 106.

Alternatively, the power generated from the first dynamo-electrical unit 101 and from the rechargeable device 106 jointly drive the second dynamo-electrical unit [103] 103a in the first drive system 1001, or the second dynamo-electrical unit [103] 103b, 103c in the second drive system 1002 or [both] all of the second dynamo-electrical units [103] 103a, 103b, 103c simultaneously.

The second dynamo-electrical unit [103] 103a in the first drive system 1001 and that in the second drive system 1002 drive the load [120] 120b1 and 120b2 jointly by utilizing the rotational kinetic energy from the active rotational power source 100 with the power from the rechargeable device 106 when the clutch 112 is engaged.

When the clutch 112 is disengaged, the brake 901 is closed, the brake 902 is disengaged, and the first dynamo-electrical unit 101 is driven by the active rotational power source 100 through the planet gear set 801 to operate as a generator, under the control of the drive control unit 104 the second dynamo-electrical unit [103] 103a operates in the serial hybrid power transmission mode by utilizing the power generated from the first dynamo-electrical unit 101.

Alternatively, the power from the rechargeable device 106 regulated by the drive control unit 104 solely drives the second dynamo-electrical unit [103] 103a to operate as a motor; or the power generated from the first dynamo-electrical unit 101 and that from the rechargeable device 106 jointly drive the second dynamo-electrical unit [103] 103a to operate as a motor under the control of the drive control unit 104.

Furthermore, the regenerated power of feedback braking regeneration provided by the second dynamo-electrical unit [103] 103a recharges the rechargeable device 106 or supply power to other electrical power driven load.

The operation between the rotary part of the second dynamo-electrical unit [103] 103a optionally adapted to the first drive system 1001 and the load [120] 120a1, 120a2 may either directly or through the optional transmission unit [109] 109c or other transmission device drive one or multiple load [120] 120a or 120a1 and 120a2; or as required, the rotary part of the second dynamo-electrical unit [103] 103a is coupled to the input terminal of the differential transmission unit [109] 109c for both differential output terminals of the differential transmission unit [109] 109c to drive their respectively adapted loads [120] 120a1 and 120a2. Accordingly, the adapted load [120] 120a is driven by the structure and operation of the first drive system 1001 as described above.

In addition, the rotational kinetic energy output terminal of the active rotational power source 100 in the first drive system 1001, or the output terminal of the transmission unit 129 coupled to the power source 100 is coupled to the input terminal of the clutch 132. The output terminal of the clutch 132 is coupled to the input terminal of the differential transmission unit [109] 109e optionally provided to the second drive system 1002 for the control of the transmission status of the rotational kinetic energy between the first drive system 1001 and the second drive system 1002.

FIG. 19 shows a block diagram of the eighteenth preferred embodiment of the split serial-parallel hybrid dual-power drive system of the present invention. The construction of the first drive system 1001 and the second drive system 1002 for the preferred embodiment illustrated in FIG. 19 is identical with that given in FIG. 16. FIG. 20 shows a block diagram of the nineteenth preferred embodiment of the split serial-parallel hybrid dual-power drive system of the present invention. The construction of the first drive system 1001 and the second drive system 1002 for the preferred embodiment illustrated in FIG. 20 is identical with that given in FIG. 17. However, the input terminal of the clutch 132 respectively illustrated in FIGS. 19 and 20 is coupled to the rotary part of the second dynamo-electrical unit [103] 103a adapted to the first drive system 1001, or to the input terminal or output terminal of the transmission unit [109] 109a adapted to the second dynamo-electrical unit [103] 103a; and the output terminal of the clutch 132 is coupled to the rotary part of the second dynamo-electrical unit [103] 103b serving as the power source for the second drive system 1002, or to the transmission unit [109] 109e optionally adapted to the rotary part of the second dynamo-electrical unit [103] 103b, or to the input terminal of the differential transmission unit [109] 109e. The clutch 132 may be optionally provided to control the transmission status between the first drive system 1001 and the second drive system 1002 while the transmission unit [109] 109b may be optionally provided to the output terminal of the active rotational power source 100 to drive the planet gear 803 of the planetary gear set 801.

FIG. 21 shows a block diagram of the twentieth preferred embodiment of the split serial-parallel hybrid dual-power drive system of the present invention. The construction of the first drive system 1001 and the second drive system 1002 for the preferred embodiment illustrated in FIG. 21 is identical with that given in FIG. 18. However, the input terminal of the clutch 132 as illustrated in FIG. 21 is coupled to the rotary part of the second dynamo-electrical unit [103] 103a adapted to the first drive system 1001, or to the input terminal or output terminal of the transmission unit [109] 109e adapted to the second dynamo-electrical unit [103] 103b, 103c while the

output terminal of the clutch 132 is coupled to the input terminal of the differential transmission unit [109] 109e optionally provided to the second drive system 1002 with both output terminals of the differential transmission unit [109] 109e respectively coupled to the rotary parts of multiple second dynamo-electrical units [103] 103b, 103c serving as the power source for the second drive system 1002. The clutch 132 may be optionally provided to control the transmission status of the rotational kinetic energy between the first drive system 1001 and the second drive system 1002 while transmission unit [109] 109b may be optionally provided to the output terminal of the active rotational power source 100 to drive the planet gear 803 of the planetary gear set 801.

The differential function of the planetary gear set adapted to the first drive system 1001 as respectively illustrated in FIGS. 16, 17, 18, 19, 20, and 21 may be replaced by the rotational gear set 1030 working on the same principles but provided in different structure.

FIG. 22 shows the twenty-first preferred embodiment of the present invention with the differential gear set to replace the separation type of the planet gear set as illustrated in FIG. 16. FIG. 23 shows the twenty-second preferred embodiment of the present invention with the differential gear set to replace the separation type of the planet gear set as illustrated in FIG. 17. In both preferred embodiments respectively illustrated in FIGS. 22 and 23, the rotational gear set 1030 substitutes the planetary gear set 801. Among the three input and output terminals of the rotational gear set 1030, the first input and output terminal 501 is coupled to the first input and output gear set 511 and to the input and output terminal of the rotational kinetic energy from the active rotational power source 100, or to the optionally provided transmission unit 129 while the transmission unit 129 is driven by the active rotational power source 100. The second input and output terminal 502 is coupled to the first dynamo-electrical unit 101, the brake 902 and the second input and output gear set 512. Both of the first and the second input and output gear sets 511, 512 are coupled to the differential gear set 5130 for a rotary arm 5131 to draw the differential output gear set 5132 and the third input and output gear set 513 for the third input and output gear set 513 to drive the third input and output terminal 503 and the rotary part of the brake 901 and the clutch 112 coupled to the third input and output terminal 503. As illustrated in FIG. 22, the other terminal of the clutch 112 might drives the load [120] 120a directly or through the optionally provided transmission unit [109] 109b. Or as illustrated in FIG. 23, the other terminal of the clutch 112 is coupled to the input terminal of the differential transmission unit [109] 109b for both differential output terminals of the differential transmission unit [109] 109b to drive their respectively adapted loads [120] 120a1 and 120a2 to constitute the first drive system 1001.

The first drive system 1001 may be optionally provided with a second dynamo-electrical unit [103] 103a. If the second dynamo-electrical unit [103] 103a is deployed, that illustrated in FIG. 22 may be coupled to the load [120] 120a directly or through the optionally provided transmission unit [109] 109b; and that illustrated in FIG. 23 may be coupled to the input terminal of the differential transmission unit [109] 109b driven by the clutch 112.

The second drive system 1002 with the second dynamo-electrical unit [103] 103b as the power source for the second drive system 1002 is coupled to the optionally provided transmission unit [109] 109f or any other transmission device to drive one or multiple load [120] 120b1, 120b2; or alternatively, the rotary part of the second dynamo-electrical unit [103] 103b is coupled to the input terminal of the differential

transmission unit [109] 109f for both differential output terminals of the differential transmission unit [109] 109f to drive their respectively adapted loads [120] 120b1, 120b2 to constitute the second drive system 1002.

Alternatively, the transmission status of the rotational kinetic energy between the first drive system 1001 and the second drive system 1002 is controlled by engaging or disengaging the clutch 132 to provide those functions described in System Functions 1 through 80.

The primary operating functions of both preferred embodiments illustrated in FIGS. 22 and 23 include that while the clutch 112 is disengaged, the brake 901 is closed and the brake 902 is disengaged, the active rotational power source 100 drives the first dynamo-electrical unit 101 through the rotational gear set 1030 to operate as a generator, through the control of the drive control unit 104, the power generated by the first dynamo-electrical unit 101 is applied to drive the second dynamo-electrical unit 103 in the first drive system 1001, or that in the second drive system 1002, or both at the same time to operate as a motor for driving the load to provide the functions of a serial hybrid power transmission.

If the rechargeable device 106 is provided, under the control of the drive control unit 104, the second dynamo-electrical unit [103] 103a, 103b operating as a motor to drive the load [120] 120a1, 120a2, 120b1 and 120b2 by receiving the power from the first dynamo-electrical unit 101 and the rechargeable device 106.

Alternatively, under the control of the drive control unit 104, the second dynamo-electrical unit [103] 103a, 103b operates as a motor to drive the load [120] 120a1, 120a2, 120b1, 120b2 by receiving the power from the rechargeable device 106.

While the brake 901 is disengaged, the brake 902 is engaged and the clutch 112 is also engaged, under the control of the drive control unit 104, the second dynamo-electrical unit [103] 103a operating as a motor to drive the load [120] 120a1, 120a2 jointly with the rotational kinetic energy from the active rotational power source 100 by receiving the power from the rechargeable device 106.

When the brake 901 is disengaged, the brake 902 is closed up, and the clutch 112 is also closed up, the rotational kinetic energy from the active rotational power source 100 drives the load 120.

The second dynamo-electrical unit [103] 103a performs power regeneration by recycling the kinetics to recharge the rechargeable device 106 or supply power to any other electrical power driven load 130.

In addition, as required, the rotational kinetic energy output terminal of the active rotational power source 100 in the first drive system 1001, or the output terminal of the transmission unit 129 coupled to the active rotational power source 100 is coupled to the input terminal of the clutch 132 while the output terminal of the clutch 132 is coupled to the rotary part of the second dynamo-electrical unit [103] 103b as the power source of the second drive system 1002, or to the output terminal of the optionally provided transmission unit [109] 109e as illustrated in FIG. 22, or coupled to the rotary part of the second dynamo-electrical unit [103] 103b of the power source of the second drive system 1002, or to the input terminal of the differential transmission unit [109] 109f of multiple loads [120] 120b1, 120b2 optionally provided to the second drive system 1002 as illustrated in FIG. 23 for the control of the transmission status of the rotational kinetic energy between the first drive system 1001 and the second drive system 1002.

FIG. 24 shows the twenty-third preferred embodiment of the present invention with the differential gear set to replace

the separation type of the planetary gear set as illustrated in FIG. 18. Wherein, the rotational gear set 1030 substitutes the planet gear set 801. Among the three input and output terminals of the rotational gear set 1030, the first input and output gear set 511, and to the input and output terminal of the rotational kinetic energy from the active rotational power source 100, or to the optionally provided transmission unit 129 while the transmission unit 129 is driven by the active rotational power source 100. The second input and output terminal 502 is coupled to the first dynamo-electrical unit 101, the brake 902 and the second input and output gear set 512. Both of the first and the second input and output gear sets 511, 512 are coupled to the differential gear set 5130 for a rotary arm 5131 to draw the differential output gear set 5132 and the third input and output gear set 513 for the third input and output gear set 513 to drive the third input and output terminal 503 and the rotary part of the brake 901 and the clutch 112 coupled to the third input and output terminal 503. The other terminal of the clutch 112 is coupled to the input terminal of the differential transmission unit [109] 109b with both differential output terminals of the differential transmission unit [109] 109b to drive their respectively adapted loads [120] 120a1, 120a2 to constitute the first drive system 1001. The first drive system 1001 may be optionally provided with a second dynamo-electrical unit [103] 103a. If the second dynamo-electrical unit [103] 103a is deployed, it may be coupled to the clutch 112 or to the input of the differential transmission unit [109] 109b driven by the clutch 112.

Each of the multiple second dynamo-electrical units [103] 103b, 103c serving as the power source for the second drive system 1002 is coupled to the optionally provided transmission unit [109] 109e or any other transmission device to drive one or multiple load [120] 120b1, 120b2 to constitute the second drive system 1002.

Alternatively, the transmission status of the rotational kinetic energy between the first drive system 1001 and the second drive system 1002 is controlled by engage or disengage the clutch 132 to provide those functions described in System Functions 1 through 80.

The primary operation functions of both preferred embodiments illustrated in FIG. 24 include that when the clutch 112 is disengaged, the brake 901 is closed and the brake 902 is disengaged, the active rotational power source 100 drives through the rotational gear set 1030 the first dynamo-electrical unit 101 to operate as a generator; and either or both of the second dynamo-electrical unit [103] 103a in the first drive system 1001 and that in the second drive system 1002 receives the power generated from the first dynamo-electrical unit 101 to operate as a motor as controlled by the drive control unit 104 to drive the load and provide those functions of the series combine power.

If the rechargeable device 106 is provided, the second dynamo-electrical unit [103] 103a, 103b, 103c by accepting the power from the first dynamo-electrical unit 101 and the rechargeable device 106 operates as a motor to drive the load [120] 120a, 120b through the control by the drive control unit 104; or the second dynamo-electrical unit [103] 103a, 103b, 103c by receiving the power from the rechargeable device 106 operates as a motor to drive the load [120] 120a, 120b through the control by the drive control unit 104.

When the brake 901 is disengaged, the brake 902 is closed up and the clutch 112 is also closed up, the second dynamo-electrical unit [103] 103a by accepting the power from the rechargeable device 106 operates as a motor to jointly drive the load [120] 120a1, 120a2 through the control by the drive

control unit **104** and the rotational kinetic energy from the active rotational power source **100**.

When the brake **901** is disengaged, the brake **902** is closed up, and the clutch **112** is also closed up, the rotational kinetic energy from the active rotational power source **100** drives the load **[120] 120a1, 120a2**.

The second dynamo-electrical unit **[103] 103a** executes power regeneration by reclaiming the kinetics to recharge the rechargeable device **106** or supply power to any other electrical power driven load **130**.

In addition, as required, the rotational kinetic energy output terminal of the active rotational power source **100** in the first drive system **1001**, or the output terminal of the transmission unit **129** coupled to the first drive system **1001** is coupled to the input terminal of the clutch **132** while the output terminal of the clutch **132** is coupled to the input of the differential transmission unit **[109] 109e** of multiple loads **[120] 120b1, 120b2** optionally provided to the second drive system **1002** for the control of the transmission status of the rotational kinetic energy between the first drive system **1001** and the second drive system **1002**.

FIG. **25** shows a block diagram of the twenty-fourth preferred embodiment of the present invention. Wherein, the differential gear substitutes the separation type of the preferred embodiment of the planetary gear set as illustrated in FIG. **19**. For the preferred embodiment illustrated in FIG. **25**, the construction of the first drive system **1001** and the second drive system **1002** is identical with illustrated in FIG. **22**. FIG. **26** shows a block diagram of the twenty-fifth preferred embodiment of the present invention. Wherein, the differential gear substitutes the separation type of the preferred embodiment of the planetary gear set as illustrated in FIG. **20**. For the preferred embodiment illustrated in FIG. **25**, the construction of the first drive system **1001** and the second drive system **1002** is identical with that as illustrated in FIG. **23**. However, the input terminal of the clutch **132** as respectively illustrated in FIGS. **25** and **26** is coupled to the rotary part of the second dynamo-electrical unit **[103] 103a** adapted to the first drive system **[101] 1001**, or to the input terminal or output terminal of the transmission unit **[109] 109e** adapted to the second dynamo-electrical unit **[103] 103b** while the output terminal of the clutch **132** is coupled to the rotary part of the second dynamo-electrical unit **[103] 103b** serving as the power source for the second drive system **1002**, or to the transmission unit **[109] 109e** optionally adapted to the rotary part of the second dynamo-electrical unit **[103] 103b**, or to the input terminal of the differential transmission unit **[109] 109e**. The clutch **132** may be optionally provided to control the transmission status of the rotational kinetic energy between the first drive system **1001** and the second drive system **1002** while the output terminal of the active rotational power source **100** may be optionally provided with a transmission unit **109** to further drive the planet gear **803** of the planetary gear set **801**.

FIG. **27** shows a block diagram of the twenty-sixth preferred embodiment of the present invention. Wherein, the differential gear substitutes the separation type of the preferred embodiment of the planetary gear set as illustrated in FIG. **21**. For the preferred embodiment illustrated in FIG. **27**, the construction of the first drive system **1001** and the second drive system **1002** is identical with that as illustrated in FIG. **24**. However, the input terminal of the clutch **132** illustrated in FIG. **27** is coupled to the rotary part of the second dynamo-electrical unit **[103] 103a** adapted to the first drive system **1001**, or to the input terminal or output terminal of the transmission unit **[109] 109b** adapted to the second dynamo-electrical unit **[103] 103a** while the output terminal of the clutch

**132** is coupled to the input terminal of the transmission unit **[109] 109d** optionally adapted to second drive system **1002** with both output terminals of the differential transmission unit **[109] 109e** respectively coupled to the rotary parts of multiple second dynamo-electrical units **[103] 103b, 103c** serving as the power source for the second drive system **1002**. The clutch **132** may be optionally provided to control the transmission status of the rotational kinetic energy between the first drive system **1001** and the second drive system **1002** while the output terminal of the active rotational power source **100** may be optionally provided with a transmission unit **[109] 109a** to further drive the planet gear **803** of the planetary gear set **801**.

The differential function provided by the planetary gear set adapted to the first drive unit **1001** respectively illustrated in FIGS. **16, 17, 18, 19, 20** and **21** is replaced with a dual motion dynamo-electrical unit providing the similar functions but different structure.

FIG. **28** shows a block diagram of the twenty-seventh preferred embodiment of the present invention, wherein, the dual motion dynamo-electrical unit substitutes the split installed planetary gear set illustrated in FIG. **16**; and FIG. **29** shows a block diagram of the twenty-eighth preferred embodiment of the present invention, wherein, the dual motion dynamo-electrical unit substitute the split installed planetary gear set illustrated in FIG. **16**. In both preferred embodiments given in FIGS. **28** and **29**, the rotary part to output the rotational kinetic energy of the active rotational power source **100** is coupled to the transmission unit **129**, the clutch **102** and the transmission unit **[109] 109a** optionally provided to drive the rotary part of the first dynamo-electrical unit **101**. In the first drive system **1001**, the dual motion dynamo-electrical unit **1040** could be implemented in the form of AC or DC, brush or brushless, synchronous or asynchronous. The dual motion dynamo-electrical unit **1040** made in a cylinder, disk or cone structure is comprised of the first rotary part **1041** and the second rotary part **1042** with the controllable clutch **122** arranged between the first and the second rotary parts **1041, 1042**. The first rotary part **1041** is coupled to the rotary part of the brake **901**, and through the clutch **112** to couple with the rotary part of the first dynamo-electrical unit **101**. The stationary part of the brake **901** is locked to the frame. The second rotary part **1042** of the dual motion dynamo-electrical unit **1040** as illustrated in FIG. **28** drives the load **[120] 120a** directly or through the optionally provided transmission unit **[109] 109b**, or as illustrated in FIG. **29**, coupled to the input terminal of the differential transmission unit **[109] 109b** with both differential output terminals of the differential transmission unit **[109] 109b** to drive their respectively adapted loads **[120] 120a1, 120a2** to constitute the first drive system **1001**.

As required, the second dynamo-electrical unit **[103] 103a** may be or may not be provided to the first drive system **1001**. While the second dynamo-electrical unit **[103] 103a** is provided, its rotary part as illustrated in FIG. **28** is coupled to the load **[120] 120a** directly or through the optionally provided transmission unit **[109] 109b**, or to the differential transmission unit **[109] 109b** driven by the second rotary part **1042** as illustrated in FIG. **29**.

The second drive system **1002** deploy the second dynamo-electrical unit **[103] 103b** as the power source to drive one or multiple load **[120] 120b or 120b1, 120b2** through the optionally provided transmission unit **[109] 109f** or any other transmission device; or the rotary part of the second dynamo-electrical unit **[103] 103b** is coupled to the input terminal of the differential transmission unit **[109] 109f** with both differential output terminals of the differential transmission unit **[109] 109f** to drive their respectively adapted loads **[120]**

120b1, 120b2 to constitute the second drive system 1002. Alternatively, by switching the clutch 132 between engaging or disengaging status to regulate the rotational kinetic energy between the first drive system 1001 and the second drive system 1002 to provide those functions described in System Functions 1 through 80.

The primary functions of both preferred embodiments given in FIGS. 28 and 29 include that while the clutch 112 is disengaged and the brake 901 is closed, the active rotational power source 100 drives the first dynamo-electrical unit 101 to operate as a generator; and either or both of the second dynamo-electrical unit [103] 103a in the first drive system 1001 and that in the second drive system 1002 receives the power generated from the first dynamo-electrical unit 101 to operate as a motor controlled by the drive control unit 104 to drive the load and provide the functions of serial hybrid power transmission.

If the rechargeable device 106 is provided, under the control of the drive control unit 104, the second dynamo-electrical unit [103] 103a, 103b receive the power from the first dynamo-electrical unit 101 and the rechargeable device 106 to operate as a motor to drive the load [120] 120a, 120b; or the second dynamo-electrical unit [103] 103a, 103b with the power from the rechargeable device 106 to operate as a motor to drive the load.

When both clutches 102, 112 are engaged, and both of the clutch 122 and the brake 901 are disengaged, under the control of the drive control unit 104 the second dynamo-electrical unit [103] 103a receive the power from the rechargeable device 106 to operate as a motor to jointly drive the load [120] 120a1, 120a2 with the rotational kinetic energy from the active rotational power source 100.

The second dynamo-electrical unit [103] 103a performs power regeneration by recycling the feedback brake kinetics to recharge the rechargeable device 106 or supply power to any other electrical power driven load 130.

Alternatively, while all the clutches 102, 112, 122 are closed up and the brake 901 is disengaged, the load [120] 120a1, 120a2 is driven by the rotational kinetic energy from the active rotational power source 100.

In addition, as required, the rotational kinetic energy output terminal of the active rotational power source 100 in the first drive system 1001, or the output terminal of the transmission unit 129 coupled to the first drive system 1001 is coupled to the input terminal of the clutch 132 while the output terminal of the clutch 132 is coupled to rotary part of the second dynamo-electrical unit [103] 103b serving as the power source for the second drive system 1002, or to the output terminal of the transmission unit [109] 109e optionally provided as illustrated in FIG. 28; or coupled to the rotary part of the second dynamo-electrical unit [103] 103b serving as the power source for the second drive system 1002, or to the input terminal of the differential transmission units [109] 109f of multiple loads [120] 120b1, 120b2 coupled to the second drive system 1002 optionally provided as illustrated in FIG. 29 for the control of the transmission status of the rotational kinetic energy between the first drive system 1001 and the second drive system 1002.

FIG. 30 shows the block diagram of the twenty-ninth preferred embodiment of the present invention. Wherein, the dual motion dynamo-electrical unit substitutes the split planetary gear set illustrated in FIG. 18. In the preferred embodiment the rotary part applied to output the rotational kinetic energy of the active rotational power source 100 is coupled to the transmission unit 129, the clutch 102 and the transmission unit [109] 109a optionally provided to drive the rotary part of the first dynamo-electrical unit 101. In the first drive system

1001, a dual motion dynamo-electrical unit 1040 made in the form of AC or DC, brush or brushless, synchronous or asynchronous is provided. The dual motion dynamo-electrical unit 1040 made in a cylinder, disk or cone shape is comprised of the first rotary part 1041 and the second rotary part 1042 with the controllable clutch 122 installed between the first and the second rotary parts 1041, 1042. The first rotary part 1041 is coupled to the rotary part of the brake 901, and further to the rotary part of the first dynamo-electrical unit 101 through the clutch 112. The stationary part of the brake 901 is locked to the frame. The second rotary part 1042 of the dual motion dynamo-electrical unit 1040 is coupled to the input terminal of the differential transmission unit [109] 109b with both differential outputs of the differential transmission unit [109] 109b to drive their respectively adapted loads [120] 120a1, 120a2 to constitute the first drive system 1001.

As required, the second dynamo-electrical unit [103] 103a may be or may not be provided to the first drive system 1001. When the second dynamo-electrical unit [103] 103a is provided, it is coupled to the second rotary part 1042 or to the input terminal of the differential transmission unit [109] 109b driven by the second rotary part 1042.

The second drive system 1002 deployed multiple second dynamo-electrical units [103] 103b, 103c as the power source drives separately coupled to the optionally transmission unit [109] 109e or any other transmission device to drive their respectively adapted loads [120] 120b1, 120b2 to constitute the second drive system 1002. Alternatively, by switching the clutch 132 to be disengaged or engaged to regulate the transmission status of the rotational kinetic energy between the first drive system 1001 and the second drive system 1002 to provide those functions described in System Functions 1 through 80.

The primary functions of the preferred embodiment given in FIGS. 30 and 29 include that when the clutch 112 is disengaged, and the brake 901 is closed, the active rotational power source 100 drives the first dynamo-electrical unit 101 to operate as a generator; under the regulation of the drive control unit 104, either or both of the second dynamo-electrical unit [103] 103a in the first drive system 1001 and that in the second drive system 1002 receive power generated from the first dynamo-electrical unit 101 to operate as a motor to drive the load and provide the function of the serial hybrid power transmission.

If the rechargeable device 106 is provided, under the control of the drive control unit 104, the second dynamo-electrical unit [103] 103a, 103b, 103c receive the power from the first dynamo-electrical unit 101 and the rechargeable device 106 operates as a motor to drive the load [120] 120a1, 120a2.

When both clutches 102, 112 are engaged, and both of the clutch 122 and the brake 901 are disengaged, under the control of the drive control unit 104 the second dynamo-electrical unit [103] 103a receive the power from the rechargeable device 106 operates as a motor for driving the load [120] 120a1, 120a2; or the second dynamo-electrical unit [103] 103a receive the power from the rechargeable device 106 to operate as a motor to jointly drive the load [120] 120a1, 120a2 with the rotational kinetic energy from the active rotational power source 100.

The second dynamo-electrical unit [103] 103a performs power regeneration by recycling the feedback brake kinetics to recharge the rechargeable device 106 or supply power to any other electrical power driven load 130.

Alternatively, when all the clutches 102, 112, 122 are engaged and the brake 901 is disengaged, the load [120] 120a1, 120a2 is driven by the rotational kinetic energy from the active rotational power source 100.



In addition, as required, the rotational kinetic energy output terminal of the active rotational power source **100** in the first drive system **1001**, or the output terminal of the transmission unit **129** coupled to the first drive system **1001** is coupled to the input terminal of the clutch **132** while the output terminal of the clutch **132** is coupled to the input terminal of the differential transmission unit **109** of multiple second dynamo-electrical unit **[103] 103b** coupled to the optionally provided second drive system **1002** for the control of the transmission status of the rotational kinetic energy between the first drive system **1001** and the second drive system **1002**.

FIG. **31** shows the block diagram of the thirtieth preferred embodiment of the present invention. Wherein, the dual motion dynamo-electrical unit substitutes the split planetary gear set illustrated in FIG. **19**. The construction of the first drive system **1001** and the second drive system **1002** of the preferred embodiment illustrated in FIG. **31** is identical with that illustrated in FIG. **28**. FIG. **32** shows the block diagram of the thirty-first preferred embodiment of the present invention. Wherein, the dual motion dynamo-electrical unit substitutes the split planetary gear set illustrated in FIG. **20**. The construction of the first drive system **1001** and the second drive system **1002** of the preferred embodiment illustrated in FIG. **32** is identical with that illustrated in FIG. **29**. The transmission unit **[109] 109a** may be also optionally provided to the output terminal of the active rotational power source **100** in the system respectively illustrated in FIGS. **31** and **32** so to further drive the planet gear **803** of the planetary gear set **801**. The clutch **132** is optionally provided for the control of the transmission status of the rotational kinetic energy between the first drive system **1001** and the second drive system **1002**. The difference respectively between both preferred embodiment given in FIGS. **31** and **32** and those in FIGS. **28** and **29** rests in that the input terminal of the clutch **132** respectively of the thirtieth and the thirty-first preferred embodiments is coupled to the rotary part of the second dynamo-electrical unit **[103] 103a** optionally adapted to the first drive system **1001**, or to the input terminal or output terminal of the transmission unit **[109] 109c** adapted to the second dynamo-electrical unit **[103] 103a** while the output terminal of the clutch **132** is coupled to the rotary part of the second dynamo-electrical unit **[103] 103b** serving as the power source for the second drive system **1002**, or to the transmission unit **[109] 109e** optionally provided to the rotary part of the second dynamo-electrical unit **[103] 103b** in the second drive system, or to the input terminal of the differential transmission unit **[109] 109f**.

FIG. **33** shows the block diagram of the thirty-second preferred embodiment of the present invention. Wherein the dual motion dynamo-electrical unit substitutes the split planet gear set illustrated in FIG. **21**. The construction of the first drive system **1001** and the second drive system **1002** of the preferred embodiment illustrated in FIG. **33** is identical with that illustrated in FIG. **30**. The transmission unit **[109] 109a** may be also optionally provided to the output terminal of the active rotational power source **100** in the system illustrated in FIG. **33** so to further drive the planet gear **803** of the planetary gear set **801**. The clutch **132** is optionally provided for the control of the transmission status of the rotational kinetic energy between the first drive system **1001** and the second drive system **1002**. The difference respectively between both preferred embodiment given in FIGS. **31** and **32** and those in FIGS. **28** and **29** rests in that the input terminal of the clutch **132** respectively of the thirtieth and the thirty-first preferred embodiments is coupled to the rotary part of the second dynamo-electrical unit **[103] 103a** optionally adapted to the

first drive system **1001**, or to the input terminal or output terminal of the transmission unit **[109] 109c** adapted to the second dynamo-electrical unit **[103] 103a** while the output terminal of the clutch **132** is coupled to the input terminal of the differential transmission unit **[109] 109e** optionally provided to the second drive system **1002** with both output terminals of the differential transmission unit **[109] 109e** to be respectively coupled to the rotary parts of multiple second dynamo-electrical units **[103] 103b, c** serving as the power source for the second drive system **1002**.

The output terminal of the active rotational power source **100** in the split serial-parallel hybrid dual-power drive system is firstly coupled to the clutch **1020**. The clutch **1020** is operating by manual, mechanical force, eccentric force, air pressure, or hydraulic flow force, or electro-magneto controlled clutch, or single way clutch, or coupler with torque control capability, or any other transmission device that transmits or interrupt the mechanical rotational kinetic energy transfer. The clutch **1020** is coupled to the transmission unit **[109] 109b** serving as the pilot drive unit **1000** and coupled to the transmission device **129** and the load **[120] 120a** to control the load **[120] 120a** driven by the pilot drive unit **1000** which generates the rotational kinetic energy. The power generated by the first dynamo-electrical unit **101** driven by the active rotational power source **100** drives the second dynamo-electrical unit **103** in the second drive system **1002** directly or under the regulation of the drive control unit **104** to provide the capability of serial hybrid power transmission, or to operate the primary functions of the parallel hybrid power transmission and other operations described in System Functions 1 through 80 under the regulation of a control system.

FIG. **34** is the first block diagram showing that a pilot drive unit is provided to the output terminal of the active rotational power source of the present invention; and FIG. **35** is a second block diagram showing that a pilot drive unit is provided to the output terminal of the active rotational power source of the present invention. Each of both preferred embodiments illustrated in FIGS. **34** and **35** essentially includes the pilot drive unit **1000** comprised of the output terminal of the active rotational power source **100** that is firstly coupled to the transmission unit **129**, the auxiliary clutch **1020**, and a transmission unit **[109] 109c** of the prior art optionally provided to drive the load **[120] 120a1, a2**. The clutch **1020** is provided to control the transmission status of the rotational kinetic energy between the active rotational power source **100** and the load **[120] 120a1, 120a2** to the pilot drive unit **1000**.

If the active rotational power source **100** is implemented in multi-shaft output, the pilot drive unit **1000** may be optionally provided to any other output terminal of the active rotational power source **100**. The clutch **102** and the transmission unit **[109] 109c** are optionally provided to the same output terminal or different output terminals of the active rotational power source **100** to drive the first dynamo-electrical unit **101** to constitute the first drive system **1001** with the pilot drive unit **1000**.

The second drive system **1002** with the second dynamo-electrical unit **103** as the power source is coupled to the transmission unit **[109] 109f** of the prior art optionally provided for driving one or multiple loads **[120] 120b1, 120b2** adapted to the transmission unit **[109] 109f** to constitute the second drive system **1002**.

The input terminal of the clutch **1020** in the pilot drive unit **1000** is coupled to the output terminal of the transmission unit **129** driven by the active rotational power source **100**, or to another output terminal of the active rotational power source **100**. As required, the transmission unit **[109] 109c** coupled between the clutch **1020** and the load **[120] 120a1, 120a2**

may be comprised of the transmission unit [109] 109c which provides the capability of controllable multistage transmission, continuously variable transmission, reversing or idling function as illustrated in FIG. 34 to drive the load [120] 120a1, 120a2, or may be comprised of the transmission unit [109] 109c which provides with the capability of controllable multistage transmission, continuously variable transmission, reversing or idling function and multiple shafts for differential output as illustrated in FIG. 35 to drive the loads [120] 120a1, 120a2 respectively adapted to each differential output terminal for differential operation.

The second drive system 1002 with the second dynamo-electrical unit 103 as the power source is coupled to the transmission unit [109] 109f of the prior art optionally provided for driving one or multiple loads [120] 120b1, 120b2 adapted to the transmission unit [109] 109f to constitute the second drive system 1002.

In the second drive system 1002, the transmission unit [109] 109e driven by the second dynamo-electrical unit 103 may be provided with the capability of controllable multistage transmission, continuously variable transmission, reversing or idling function as illustrated in FIG. 34 to drive the load [120] 120b1, 120b2, or in the form of the transmission unit [109] 109e that is provided with the capability of controllable multistage transmission, continuously variable transmission, reversing or idling function and multiple shafts for the operation of differential output as illustrated in FIG. 35 to drive the loads [120] 120b1, 120b2 respectively adapted to each differential output terminal for differential transmission.

As required, the clutch 102 coupled to the output terminal of the active rotational power source 100 through the transmission unit 129, the optionally provided transmission unit [109] 109d and the first dynamo-electrical unit 101 may be coupled with the first drive system 1001, or coupled with the second drive system 1002 or provide standalone operation.

In the system respectively illustrated in FIGS. 34 and 35, while driving the pilot drive unit 1000, the operation of the active rotational power source 100 may further include driving the first dynamo-electrical unit 101 by the active rotational power source 100 to operate as a generator with the power generated to drive the second dynamo-electrical unit 103 in the second drive system 1002 to produce the rotational kinetic energy to drive the load [120] 120b1, 120b2 for the system to provide the serial hybrid power transmission.

When the rechargeable device 106 is provided to the system, the active rotational power source 100 drives the first dynamo-electrical unit 101 to operate as a generator with the power generated to recharge the rechargeable device 106 or supply power to any other electrical power driven load 130 (including any externally connected unspecified load), and drive the second dynamo-electrical unit 103 in the second drive system 1002 to drive the load [120] 120b1, 120b2.

When the system is provided with the rechargeable device 106, the active rotational power source 100 drives the first dynamo-electrical unit 101 to operate as a generator to recharge the rechargeable device 106 or to supply power to other electrical power driven load 130 (including any externally connected unspecified load).

The first dynamo-electrical unit 101 operates as a generator with the power from the rechargeable device 106 to jointly drive the second dynamo-electrical unit 103 to produce the rotational kinetic energy to drive the load [120] 120b1, 120b2 or supply power to any other electrical power driven load 130 (including any externally connected unspecified load).

The power from the rechargeable device 106 drives the second dynamo-electrical unit 103 in the second drive system 1002 to generate the rotational kinetic energy for driving the load.

The power from the rechargeable device 106 drives the second dynamo-electrical unit 103 in the second drive system 1002 to generate the rotational kinetic energy for jointly driving the load with the power from the active rotational power source 100.

The recycled power from feedback braking regeneration by the first dynamo-electrical unit 101 or the second dynamo-electrical unit 103 recharges the rechargeable device 106 or supply power to any other electrical power driven load 130 (including any externally connected unspecified load).

FIG. 36 is the third block diagram showing that a pilot drive unit is provided to the output terminal of the active rotational power source of the present invention. The preferred embodiment illustrated in FIG. 36 includes the pilot drive unit 1000 comprised of the output terminal of the active rotational power source 100 that is coupled first to the transmission unit 129, the auxiliary clutch 1020, and a transmission unit [109] 109c of the prior art optionally provided to drive the load [120] 120a. The clutch 1020 is provided to control the transmission status of the rotational kinetic energy between the active rotational power source 100 and the load [120] 120a to the pilot drive unit 1000.

If the active rotational power source 100 is implemented with a multi-shaft output, the pilot drive unit 1000 may be optionally provided to any other output terminal of the active rotational power source 100. The clutch 102 and the transmission unit [109] 109b are optionally provided to the same output terminal or different output terminals of the active rotational power source 100 to drive the first dynamo-electrical unit 101 to constitute the first drive system 1001 with the pilot drive unit 1000.

The input terminal of the clutch 1020 in the pilot drive unit 1000 is coupled to the output terminal of the transmission unit 129 driven by the active rotational power source 100, or to another output terminal of the active rotational power source 100. The input terminal of the clutch 1020 is coupled to the output terminal of the transmission unit 129 driven by the active rotational power source 100 or to the other output terminal of the active rotational power source 100. As required, the transmission unit [109] 109c coupled between the clutch 1020 and the load [120] 120a1, 120a2 may be comprised of the transmission unit [109] 109c which provides the capability of controllable multistage transmission, continuously variable transmission, reversing or idling function or may be comprised of the transmission unit [109] 109c which provides the capability of controllable multistage transmission, continuously variable transmission, reversing or idling function and multiple shafts for the operation of differential output to drive the loads [120] 120a1, 120a2 respectively adapted to each differential output terminal for differential operation.

The second drive system 1002 with the second dynamo-electrical unit [103] 103b, 103c as the power source is coupled to the transmission unit [109] 109e1, 109e2 of the prior art optionally provided for driving one or multiple loads [120] 120b1, 120b2 adapted to the transmission unit [109] 109e1, 109e2 to constitute the second drive system 1002.

In the second drive system 1002, the transmission unit 109 driven by the second dynamo-electrical unit 103 may be provided with the capability of controllable multistage transmission, continuously variable transmission, reversing or idling function as illustrated in FIG. 34 to drive the load [120] 120b, or in the form of the transmission unit [109] 109e that

is provided with the capability of controllable multistage transmission, continuously variable transmission, reversing or idling function and multiple shafts for the operation of differential output to drive the loads [120] 120b1, 120b2 respectively adapted to each differential output terminal for differential operation.

As required, the clutch 102 coupled to the output terminal of the active rotational power source 100 through the transmission unit 129, the optionally provided transmission unit [109] 109b and the first dynamo-electrical unit 101 may be coupled with the first drive system 1001, or coupled with the second drive system 1002 or provide standalone operation.

In the system illustrated in FIG. 36, while driving the pilot drive unit 1000, the operation of the active rotational power source 100 may further drive the first dynamo-electrical unit 101 by the active rotational power source 100 to operate as a generator with the power generated to drive multiple second dynamo-electrical units [103] 103b, 103c in the second drive system 1002 to produce the rotational kinetic energy to drive the load [120] 120b1, 120b2 for the system to provide the serial hybrid power transmission.

When the rechargeable device 106 is provided to the system, the active rotational power source 100 drives the first dynamo-electrical unit 101 to operate as a generator with the power generated to recharge the rechargeable device 106 or supply power to any other electrical power driven load 130 (including any externally connected unspecified load), and drive multiple second dynamo-electrical units [103] 103b, 103c in the second drive system 1002 to drive the load [120] 120b1, 120b2.

When the system is provided with the rechargeable device 106, the active rotational power source 100 drives the first dynamo-electrical unit 101 to operate as a generator with the power generated to recharge the rechargeable device 106 or to supply power to other electrical power driven load 130 (including any externally connected unspecified load).

When the first dynamo-electrical unit 101 operates as a generator, the power generated and that from the rechargeable device 106 jointly drive the second dynamo-electrical unit [103] 103a to produce the rotational kinetic energy to drive the load [120] 120a1, 120a2 or supply power to any other electrical power driven load 130 (including any externally connected unspecified load).

The power from the rechargeable device 106 drives alone the second dynamo-electrical unit [103] 103b, 103c in the second drive system 1002 to produce the rotational kinetic energy for driving the load; or the rotational kinetic energy produced by the second dynamo-electrical unit [103] 103b, 103c in the second drive system 1002 as driven by the power from the rechargeable device 106 and that from the active rotational power source 100 jointly drive the load.

The recycled power from feedback braking regeneration by the first dynamo-electrical unit 101 or the second dynamo-electrical unit [103] 103a recharges the rechargeable device 106 or supply power to any other electrical power driven load 130 (including any externally connected unspecified load).

FIG. 37 is the fourth block diagram showing that a pilot drive unit is provided to the output terminal of the active rotational power source of the present invention. FIG. 38 is the fifth block diagram showing that a pilot drive unit is provided to the output terminal of the active rotational power source of the present invention. In both preferred embodiments illustrated in FIGS. 37 and 38, the clutch 132 is installed between the rotary part of the first dynamo-electrical unit 101 and the rotary part of the second drive system 1002. The system essentially includes the pilot drive unit 1000 comprised of the output terminal of the active rotational

power source 100 that is coupled first to the transmission unit 129, the auxiliary clutch 1020, and a transmission unit [109] 109d of the prior art optionally provided to drive the load [120] 120a. The clutch 1020 is provided to control the transmission status of the rotational kinetic energy between the active rotational power source 100 and the load [120] 120a to the pilot drive unit 1000.

If the active rotational power source 100 is implemented with a multi-shaft output, the pilot drive unit 1000 may be optionally provided to any other output terminal of the active rotational power source 100. The clutch 102 and the transmission unit [109] 109b are optionally provided to the same output terminal or different output terminals of the active rotational power source 100 to drive the first dynamo-electrical unit 101 to constitute the first drive system 1001 with the pilot drive unit 1000.

The input terminal of the clutch 1020 in the pilot drive unit 1000 is coupled to the output terminal of the transmission unit 129 driven by the active rotational power source 100, or to another output terminal of the active rotational power source 100. As required, the transmission unit [109] 109d coupled between the clutch 1020 and the load [120] 120a1, 120a2 may be comprised of the transmission unit [109] 109d which provides the capability of controllable multistage transmission, continuously variable transmission, reversing or idling function as illustrated in FIG. 37 to drive the load [120] 120a1, 120a2, or may be comprised of the transmission unit [109] 109d which provides the capability of controllable multistage transmission, continuously variable transmission, reversing or idling function and multiple shafts for the operation of differential output as illustrated in FIG. 38 to drive the loads [120] 120a1, 120a2 respectively adapted to each differential output terminal for differential operation.

Furthermore, the rotary part of the first dynamo-electrical unit 101 adapted to the first drive system 1001, or the rotary part of the optionally provided transmission unit [109] 109c coupled to the first drive system 1001 is coupled to the input terminal of the clutch 132 while the output terminal of the clutch 132 is coupled to the rotary part of the second dynamo-electrical unit 103 serving as the power source for the second drive system 1002, or to the input terminal of the differential transmission unit [109] 109e coupled to the rotary part of the second dynamo-electrical unit 103 in the second drive system 1002. Both differential output terminals of the differential transmission unit [109] 109f are coupled to their respectively adapted loads [120] 120b1, 120b2 while the clutch 132 is used to control the transmission status of the rotational kinetic energy between the first drive system 1001 and the second drive system 1002.

The second drive system 1002 with the second dynamo-electrical unit 103 as the power source is coupled to the transmission unit [109] 109f of the prior art optionally provided for driving one or multiple loads [120] 120b1, 120b2 adapted to the transmission unit [109] 109e to constitute the second drive system 1002.

In the second drive system 1002, the transmission unit [109] 109f driven by the second dynamo-electrical unit 103 may be provided in the form of the transmission unit [109] 109f which provides the capability of controllable multistage transmission, continuously variable transmission, reversing or idling function as illustrated in FIG. 37 to drive the load [120] 120b1, 120b2, or in the form of the transmission unit [109] 109f which provides the capability of controllable multistage transmission, continuously variable transmission, reversing or idling function and multiple shafts for the operation of differential output as illustrated in FIG. 38 to drive the

loads [120] 120b1, 120b2 respectively adapted to each differential output terminal for differential operation.

As required, the clutch 102 coupled to the output end of the active rotational power source 100 through the transmission unit 129, the optionally provided transmission unit [109] 109b, and the first dynamo-electrical unit 101 may be coupled with the first drive system 1001, or coupled with the second drive system 1002 or provide standalone operation.

In the system respectively illustrated in FIGS. 37 and 38, while driving the pilot drive unit 1000, the operation of the active rotational power source 100 may further drive the first dynamo-electrical unit 101 by the active rotational power source 100 to operate as a generator with the power generated to drive the second dynamo-electrical unit 103 in the second drive system 1002 to produce the rotational kinetic energy to drive the load [120] 120b1, 120b2 for the system to provide the serial hybrid power transmission.

When the rechargeable device 106 is provided to the system, the active rotational power source 100 drives the first dynamo-electrical unit 101 to operate as a generator with the power generated to recharge the rechargeable device 106 or supply power to any other electrical power driven load 130 (including any externally connected unspecified load), and drive the second dynamo-electrical unit 103 in the second drive system 1002 to produce the rotational kinetic energy for driving the load [120] 120b1, 120b2.

When the system is provided with the rechargeable device 106, the active rotational power source 100 drives the first dynamo-electrical unit 101 to operate as a generator with the power generated to recharge the rechargeable device 106 or supply power to any other electrical power driven load 130 (including any externally connected unspecified load).

The first dynamo-electrical unit 101 operates as a generator with the power generated and that from the rechargeable device 106 to jointly drive the second dynamo-electrical unit 103 to produce the rotational kinetic energy to drive the load [120] 120b1, 120b2 or supply power to any other electrical power driven load 130 (including any externally connected unspecified load); or the power from the rechargeable device 106 alone drives the second dynamo-electrical unit 103 adapted in the second drive system 1002 to produce the rotational kinetic energy to drive the load.

The rotational kinetic energy produced by the second dynamo-electrical unit 103 in the second drive system 1002 as driven by the power from the rechargeable device 106 and that from the active rotational power source 100 jointly drive the load.

The recycled power from feedback braking regeneration by the first dynamo-electrical unit 101 or the second dynamo-electrical unit 103 recharges the rechargeable device 106 or supply power to any other electrical power driven load 130 (including any externally connected unspecified load); or the transmission status of the rotational kinetic energy between the first drive system 1001 and the second drive system 1002 is controlled by switching the clutch 132 to disengaged or engaged state.

FIG. 39 is the sixth block diagram showing that a pilot drive unit is provided to the output terminal of the active rotational power source of the present invention. In the preferred embodiment illustrated in FIG. 39, the controllable clutch 132 is installed between the rotary part of the first dynamo-electrical unit 101 and the rotary part of the second drive system 1002. The system essentially include the pilot drive unit 1000 comprised of the active rotational power source 100 that is coupled first to the transmission unit 129, the auxiliary clutch 1020, and a transmission unit [109] 109d of the prior art optionally provided to drive the load [120] 120a1, 120a2.

The clutch 1020 is provided to control the transmission status of the rotational kinetic energy between the active rotational power source 100 and the load [120] 120a1, 120a2 to the pilot drive unit 1000.

If the active rotational power source 100 is implemented with a multi-shaft output, the pilot drive unit 1000 may be optionally provided to any other output terminal of the active rotational power source 100. The clutch 102 and the transmission unit [109] 109b are optionally provided to the same output terminal or different output terminals of the active rotational power source 100 to drive the first dynamo-electrical unit 101 to constitute the first drive system 1001 with the pilot drive unit 1000.

The input terminal of the clutch 1020 in the pilot drive unit 1000 is coupled to the output terminal of the transmission unit 129 driven by the active rotational power source 100, or to another output terminal of the active rotational power source 100. As required, the transmission unit [109] 109d coupled between the clutch 1020 and the load [120] 120a1, a2 may be comprised of the transmission unit [109] 109d which provides the capability of controllable multistage transmission, continuously variable transmission, reversing or idling function or may be comprised of the transmission unit [109] 109d which provides the capability of controllable multistage transmission, continuously variable transmission, reversing or idling function and multiple shafts for the operation of differential output to drive the loads [120] 120a1, a2 respectively adapted to each differential output terminal for differential operation.

Furthermore as required, the rotary part of the first dynamo-electrical unit 101 adapted to the first drive system 1001, or that of the optionally provided transmission unit [109] 109c coupled to the first drive system 1001 is coupled to the input terminal of the clutch 132 while the output terminal of the clutch 132 is coupled to two rotary parts of both second dynamo-electrical units [103] 103b, 103c serving as the power source for the second drive unit 1002, or coupled to the input terminal of the differential transmission unit [109] 109e operationally adapted to the second drive system 1002. With the two differential output terminals of the differential transmission unit [109] 109e coupled to rotary parts of multiple second dynamo-electrical units [103] 103b, 103c, the transmission status of the rotational kinetic energy between the first drive system 1001 and the second drive system 1002 is controlled through the clutch 132.

If multiple loads are provided to the pilot drive unit 1000 or to the second drive system 1002 and a differential operation function is required among the loads [120] 120a, 120b, the transmission unit [109] 109d coupled between the clutch 1020 of the pilot drive unit 1000 and the load [120] 120a1, 120a2 may be provided with the capability of controllable multistage transmission, reversing or idling functions; or may be further provided in a construction of a transmission unit that is provided with multiple output shafts with the capability of controllable multistage transmission, reversing or idling functions for differential transmission output so to drive each load [120] 120a1, 120a2 coupled to the differential output terminals.

The second drive system 1002 with the second dynamo-electrical unit [103] 103b, 103c as the power source is coupled to the transmission unit [109] 109e of the prior art optionally provided for driving one or multiple loads [120] 120b1, 120b2 adapted to the transmission unit [109] 109e to constitute the second drive system 1002.

The differential transmission unit [109] 109e is provided to the second drive system 1002 to be driven by the clutch 132. Both output terminals of the differential transmission unit

**[109] 109e** are respectively coupled to the rotary parts from multiple second dynamo-electrical units **[103] 103b, 103c**. As required, the differential transmission unit **[109] 109e** may be provided with controllable multistage transmission, continuously variable transmission, reversing or idling function, and multiple shafts output for the operation of differential output to drive the loads **[120] 120b1, 120b2** respectively adapted to each differential output terminal for differential operation.

While being incorporated to the first drive system **1001**, the clutch **102** coupled to the output terminal of the active rotational power source **100** through the transmission unit **129** and the clutch **132**, the optionally provided transmission unit **109** and the clutch **132** and the first dynamo-electrical unit **101** may be incorporated to the second drive system **1002** or standalone operating as required.

In the system illustrated in FIG. 39, while the clutch **132** disengaged, the primary operation of the active rotational power source **100** driving the pilot drive unit **1000** may further drive the first dynamo-electrical unit **101** by the active rotational power source **100** to operate as a generator with the generated power to drive multiple second dynamo-electrical units **103** in the second drive system **1002** to produce the rotational kinetic energy to drive the load **[120] 120b1, 120b2** for the system to provide the serial hybrid power transmission.

When the rechargeable device **106** is provided to the system, the active rotational power source **100** drives the first dynamo-electrical unit **101** to operate as a generator to recharge the rechargeable device **106** or supply power to any other electrical power driven load **130** (including any externally connected unspecified load), and drive two or multiple second dynamo-electrical units **103** in the second drive system **1002** to produce rotational kinetic energy for driving the load **[120] 120b1, 120b2**.

When the system is provided with the rechargeable device **106**, the active rotational power source **100** drives the first dynamo-electrical unit **101** to operate as a generator to recharge the rechargeable device **106** or to supply power to other electrical power driven load **130** (including any externally connected unspecified load).

When the first dynamo-electrical unit **101** operates as a generator, the generated power and power from the rechargeable device **106** jointly drive the second dynamo-electrical unit **103** to produce the rotational kinetic energy to drive the load **[120] 120b1, 120b2** or supply power to any other electrical power driven load **130** (including any externally connected unspecified load).

The power from the rechargeable device **106** drives alone the second dynamo-electrical unit **103** in the second drive system **1002** to produce the rotational kinetic energy for driving the load; or the rotational kinetic energy generated by the second dynamo-electrical unit **103** in the second drive system **1002** as driven by the power from the rechargeable device **106** drive the load jointly with the power from the active rotational power source **100**.

The regenerated power of feedback braking regeneration by the first dynamo-electrical unit **101** or the second dynamo-electrical unit **103** recharges the rechargeable device **106** or supply power to any other electrical power driven load **130** (including any externally connected unspecified load); or the transmission status of the rotational kinetic energy between the first drive system **1001** and the second drive system **1002** is regulated by switching the clutch **132** to engage or disengaged state.

FIG. 40 is the seventh block diagram showing the pilot drive unit provided to the output terminal of the active rotational power source of the present invention; and FIG. 41 is

the eighth block diagram showing the pilot drive unit is provided to the output terminal of the active rotational power source of the present invention. Both preferred embodiments respectively illustrated in FIGS. 40 and 41, the controllable clutch **132** is installed between the transmission unit **129** coupled to the output terminal of the active rotational power source **100** and the rotary part of the second drive system **1002**, and essentially include the pilot drive unit **1000** comprised of the rotational power source **100** that is coupled first to the transmission unit **129**, the auxiliary clutch **1020**, and a transmission unit **[109] 109a** of the prior art optionally provided to drive the load **[120] 120a1, 120a2**. The clutch **1020** is provided to control the transmission status of the rotational kinetic energy between the active rotational power source **100** and the load **[120] 120a1, 120a2** to the pilot drive unit **1000**.

If the active rotational power source **100** is implemented with a multi-shaft output, the pilot drive unit **1000** may be optionally provided to any other output terminal of the active rotational power source **100**. The clutch **102** and the transmission unit **[109] 109b** are optionally provided to the same output terminal or different output terminals of the active rotational power source **100** to drive the first dynamo-electrical unit **101** to constitute the first drive system **1001** with the pilot drive unit **1000**.

The input terminal of the clutch **1020** in the pilot drive unit **1000** is coupled to the output terminal of the transmission unit **129** driven by the active rotational power source **100**, or to another output terminal of the active rotational power source **100**. The transmission unit **[109] 109a** coupled at where between the clutch **1020** and the load **[120] 120a1, 120a2** may be comprised of the transmission unit **109** which provides the capability of controllable multistage transmission, continuously variable transmission, reversing or idling function as illustrated in FIG. 40 or may be comprised of the transmission unit **[109] 109a** which provides the capability of controllable multistage transmission, continuously variable transmission, reversing or idling function and multiple shafts for the operation of differential output to drive the loads **[120] 120a1, 120a2** respectively adapted to each differential output terminal for executing the differential operation as illustrated in FIG. 41

Furthermore, as required, the transmission unit **129** coupled to the output terminal of the active rotational power source **100** adapted to the first drive system **1001** is coupled to the input terminal of the clutch **132** while the output terminal of the clutch **132** is coupled to the rotary part of the second dynamo-electrical unit **103** serving as the power source for the second drive system **1002**, or to the input terminal of the differential transmission unit **[109] 109f** optionally provided in the second drive system **1002** to be coupled to the rotary part of the second dynamo-electrical unit **103**. Both differential output terminals of the differential transmission unit **[109] 109f** are coupled to their respectively adapted loads **[120] 120b1, 120b2** for the control of the transmission status of the rotational kinetic energy between the first drive system **1001** and the second drive system **1002** through the control by the clutch **132**.

The second drive system **1002** with the second dynamo-electrical unit **103** as the power source is coupled to the transmission unit **[109] 109f** of the prior art optionally provided for driving one or multiple loads **[120] 120b1, 120b2** adapted to the transmission unit **[109] 109f** to constitute the second drive system **1002**.

In the second drive system **1002**, the transmission unit **[109] 109f** driven by the second dynamo-electrical unit **103** may be provided in the form of the transmission unit **[109] 109f** which provides the capability of controllable multistage

transmission, continuously variable transmission, reversing or idling function as illustrated in FIG. 40 to drive the load [120] 120b, or in the form of the transmission unit [109] 109f which provides the capability of controllable multistage transmission, continuously variable transmission, reversing or idling function and multiple shafts for the operation of differential output to drive the loads [120] 120b1, 120b2 respectively adapted to each differential output terminal for executing the differential operation as illustrated in FIG. 41.

While being incorporated to the first drive system 1001, the clutch 102 coupled to the output terminal of the active rotational power source 100 through the transmission unit 129, the optionally provided transmission unit [109] 109b and the first dynamo-electrical unit 101 may be incorporated to the second drive system 1002 or provided standalone operation as required.

In the system respectively illustrated in FIGS. 40 and 41, while driving the pilot drive unit 1000, the operation of the active rotational power source 100 may further drive the first dynamo-electrical unit 101 by the active rotational power source 100 to operate as a generator with the power generated to drive two or multiple second dynamo-electrical units 103 in the second drive system 1002 to produce the rotational kinetic energy to drive the load [120] 120b1, 120b2 for the system to provide the serial hybrid power transmission.

When the rechargeable device 106 is provided to the system, the active rotational power source 100 drives the first dynamo-electrical unit 101 to operate as a generator with the power generated to recharge the rechargeable device 106 or supply power to any other electrical power driven load 130 (including any externally connected unspecified load), and drive two or multiple second dynamo-electrical units 103 in the second drive system 1002 to produce rotational kinetic energy for driving the load [120] 120b1, 120b2.

When the system is provided with the rechargeable device 106, the active rotational power source 100 drives the first dynamo-electrical unit 101 to operate as a generator to recharge the rechargeable device 106 or to supply power to other electrical power driven load 130 (including any externally connected unspecified load).

When the first dynamo-electrical unit 101 operates as a generator, the generated power and power from the rechargeable device 106 jointly drive the second dynamo-electrical unit 103 to produce the rotational kinetic energy to drive the load [120] 120a, 120b or supply power to any other electrical power driven load 130 (including any externally connected unspecified load).

The power from the rechargeable device 106 drives alone the second dynamo-electrical unit 103 in the second drive system 1002 to produce the rotational kinetic energy for driving the load; or the rotational kinetic energy produced by the second dynamo-electrical unit 103 in the second drive system 1002 as driven by the power from the rechargeable device 106 and that from the active rotational power source 100 jointly drive the load.

The regenerated power of feedback braking regeneration power by the first dynamo-electrical unit 101 or the second dynamo-electrical unit 103 recharges the rechargeable device 106 or supply power to any other electrical power driven load 130 (including any externally connected unspecified load); or the transmission status of the rotational kinetic energy between the first drive system 1001 and the second drive system 1002 is regulated by switching the clutch 132 to engage or disengage status to perform the System Functions 1 through 80.

FIG. 42 is the ninth block diagram showing that the pilot drive unit is provided to the output terminal of the active

rotational power source of the present invention. Wherein, the controllable clutch 132 is installed between the transmission unit 129 coupled to the output terminal of the active rotational power source 100 and the rotary part of the second drive system 1002, and essentially include the pilot drive unit 1000 comprised of having first coupled the transmission unit 129, the auxiliary clutch 1020 and the transmission unit [109] 109a of the prior art optionally provided to drive the load [120] 120a1, 120a2. The clutch 1020 is provided to regulate the transmission status of the rotational kinetic energy between the active rotational power source 100 and the load [120] 120a1, 120a2 to the pilot drive unit 1000.

If the active rotational power source 100 is implemented with a multi-shaft output, the pilot drive unit 1000 may be optionally provided to any other output terminal of the active rotational power source 100. The clutch 102 and the transmission unit 109 are optionally provided to the same output terminal or different output terminals of the active rotational power source 100 to drive the first dynamo-electrical unit 101 to constitute the first drive system 1001 with the pilot drive unit 1000.

The input terminal of the clutch 1020 in the pilot drive unit 1000 is coupled to the output terminal of the transmission unit 129 driven by the active rotational power source 100, or to another output terminal of the active rotational power source 100. As required, the transmission unit [109] 109a coupled between the clutch 1020 and the load [120] 120a1, 120a2 may be comprised of the transmission unit [109] 109a which provides the capability of controllable multistage transmission, continuously variable transmission, reversing or idling function or may be comprised of the transmission unit [109] 109a which provides the capability of controllable multistage transmission, continuously variable transmission, reversing or idling function and multiple shafts for the operation of differential output to drive the loads [120] 120a1, 120a2 respectively adapted to each differential output terminal for differential operation.

Furthermore, as required, the transmission unit 129 coupled to the output terminal of the active rotational power source 100 adapted to the first drive system 1001 is coupled to the input terminal of the clutch 132 while the output terminal of the clutch 132 is coupled to the rotary parts of both second dynamo-electrical units [103] 103b, 103c, or to the input terminal of the differential transmission unit [109] 109e optionally adapted to the second drive system 1002. With two differential output terminals of the differential transmission unit [109] 109e coupled to rotary parts of multiple second dynamo-electrical units [103] 103b, 103c, the transmission status of the rotational kinetic energy between the first drive system 1001 and the second drive system 1002 is regulated through the clutch 132.

If multiple loads are provided to the pilot drive unit 1000 or to the second drive system 1002 and a differential operation function is required among the loads [120] 120a1, 120a2 or 120b1, 120b2, the transmission unit [109] 109a coupled between the clutch 1020 of the pilot drive unit 1000 and the load [120] 120a1, 120a2 may be provided in the construction of a transmission unit which provides the capability of controllable transmission, reversing or idling functions; or may be further provided in a construction of the transmission unit [109] 109a that is provided with multiple shafts for executing differential transmission output so to drive each load [120] 120a1, 120a2 coupled to the differential output terminal to execute the differential operation.

The second drive system 1002 with the second dynamo-electrical unit 103 as the power source is coupled to the transmission unit [109] 109e of the prior art optionally pro-

vided for driving one or multiple loads **[120]** *120b1*, *120b2* adapted to the transmission unit **[109]** *109e* to constitute the second drive system **1002**.

The differential transmission unit **[109]** *109e* is provided to the second drive system **1002** to be driven by the clutch **132**. Both output terminals of the differential transmission unit **[109]** *109e* are respectively coupled to the rotary parts from multiple second dynamo-electrical units **[103]** *103b*, *103c*. As required, the differential transmission unit **[109]** *109e* may be provided with controllable multistage transmission, continuously variable transmission, reversing or idling function, and multiple shafts for the operation of differential output to drive the loads **[120]** *120b1*, *120b2* respectively adapted to each differential output terminal for differential operation.

While being incorporated to the first drive system **1001**, the clutch **102** coupled to the output end of the active rotational power source **100** through the transmission unit **129**, the optionally provided transmission unit **[109]** *109c* and the clutch **132** and the first dynamo-electrical unit **101** may be incorporated to the second drive system **1002** or provided standing alone as required.

In the system illustrated in FIG. **42**, while the clutch **132** disengaged, the primary operation of the active rotational power source **100** driving the pilot drive unit **1000** may further drive the first dynamo-electrical unit **101** by the active rotational power source **100** to operate as a generator with the power generated to drive two or multiple second dynamo-electrical units **[103]** *103b*, *103c* in the second drive system **1002** to produce the rotational kinetic energy to drive the load **[120]** *120b1*, *120b2* for the system to provide the serial hybrid power transmission.

When the rechargeable device **106** is provided to the system, the active rotational power source **100** drives the first dynamo-electrical unit **101** to operate as a generator with the power generated to recharge the rechargeable device **106** or supply power to any other electrical power driven load **130** (including any externally connected unspecified load), and drive two or multiple second dynamo-electrical units **[103]** *103b*, *103c* in the second drive system **1002** to produce rotational kinetic energy for driving the load **[120]** *120b1*, *120b2*.

When the system is provided with the rechargeable device **106**, the active rotational power source **100** drives the first dynamo-electrical unit **101** to operate as a generator to recharge the rechargeable device **106** or to supply power to other electrical power driven load **130** (including any externally connected unspecified load).

When the first dynamo-electrical unit **101** operates as a generator, the generated power and the power from the rechargeable device **106** jointly drive the second dynamo-electrical unit **103** to produce the rotational kinetic energy to drive the load **[120]** *120a1*, *120a2* or supply power to any other electrical power driven load **130** (including any externally connected unspecified load).

The power from the rechargeable device **106** drives alone the second dynamo-electrical unit **[103]** *103b*, *103c* in the second drive system **1002** to generate the rotational kinetic energy for driving the load; or the rotational kinetic energy produced by the second dynamo-electrical unit **[103]** *103b*, *103c* in the second drive system **1002** as driven by the power from the rechargeable device **106** jointly drive the load **[120]** *120b1*, *120b2* with the power from the active rotational power source **100**.

The regenerated power of feedback braking regeneration by the first dynamo-electrical unit **101** or the second dynamo-electrical unit **[103]** *103b*, *103c* recharges the rechargeable device **106** or supply power to any other electrical power driven load **130** (including any externally connected unspeci-

fied load); or the transmission status of the rotational kinetic energy between the first drive system **1001** and the second drive system **1002** is controlled by switching the clutch **132** to engage or disengage state for the system to operating with those System Functions 1 through 80.

FIG. **43** is the tenth block diagram showing that a pilot drive unit is provided to the output terminal of the active rotational power source of the present invention; and FIG. **44** is the eleventh block diagram showing that a pilot drive unit is provided to the output terminal of the active rotational power source of the present invention. Both preferred embodiments respectively illustrated in FIGS. **43** and **44** are each comprised of the first drive system **1001** and the second drive system **1002**. The construction of the first drive system **1001** includes the pilot drive unit **1000** comprised with the output shaft of the active rotational power source **100** coupled to the additionally provided transmission unit **129**, and further to the auxiliary clutch **1020** and the optionally provided transmission unit **[109]** *109a* of the prior art to drive the load **[120]** *120a1*, *120a2*, and the active rotational power source **100**.

The input terminal of the clutch **1020** in the pilot drive unit **1000** is coupled to the output terminal of the transmission unit **129** driven by the active rotational power source **100**, or to another output terminal of the active rotational power source **100**. The transmission unit **[109]** *109a* coupled between the clutch **1020** and the load **[120]** *120a* may be comprised of the transmission unit **[109]** *109a* which provides the capability of controllable multistage transmission, continuously variable transmission, reversing or idling function as illustrated in FIG. **43** or may be comprised of the transmission unit **[109]** *109a* which provides the capability of controllable multistage transmission, continuously variable transmission, reversing or idling function and multiple shafts for the operation of differential output to drive the loads **[120]** *120a1*, *120a2* respectively adapted to each differential output terminal for differential operation as illustrated in FIG. **44**.

Another output terminal of the transmission unit **129** is provided to drive the planet gear **803** of the planetary gear set **801**. The rotary part of the first dynamo-electrical unit **101** is coupled to the sun gear **802** of the planetary gear set **801**. The operation between the rotary part and the stationary part of the first dynamo-electrical unit **101** as required may function as a motor under the regulation of the drive control unit **104** to output the rotational kinetic energy, or as a generator to produce damping while generating the power for the damping to make the rotational kinetic energy from the active rotational power source **100** to be routed to the external gear **804**, or under the regulation of the drive control unit **104** to control the electromagnetic lock up operation between the stationary part and the rotary part of the first dynamo-electrical unit **101**. The EM lockup function may be replaced by the brake **902** when required with the rotary part of the first dynamo-electrical unit **101** coupled to the rotation side of the brake **902** and the stationary part of the brake **902** locked to the frame or to the stationary part of the first dynamo-electrical unit **101** for locking up the first dynamo-electrical unit **101** and routing the rotational kinetic energy from the active rotational power source **100** to be transfer through the external gear **804**.

To compromise the operation of the system, the brake **901** is required for the active rotational power source **100** to drive the first dynamo-electrical unit **101** to operate as a generator. The external gear **804** of the planetary gear set **801** is coupled to the input terminal of the clutch **132** and coupled to the rotation side of the brake **901**; the stationary part of the brake **901** is locked to the frame; and another end of the clutch **132** is coupled to the rotary part of the second dynamo-electrical unit **103** in the second drive system **1002**, or to the input

terminal of the optionally provided transmission unit **109** in the second drive system **1002**. The optionally provided clutch **132** controls the transmission of the rotational kinetic energy between the first drive unit **1001** and the second drive unit **1002** while the clutch **132** and the brake **901** may be split installed or share the compact structure.

The second drive system **1002** as illustrated in FIG. **43** is comprised of the second dynamo-electrical unit **103** serving as the power source coupled to the optionally provided transmission unit **[109] 109f** or any other transmission device to drive one or multiple load **[120] 120b1, 120b2**; or as illustrated in FIG. **44**, the rotary part of the second dynamo-electrical unit **[103] 103b, 103c** as required is coupled to the input terminal of the differential transmission unit **[109] 109f**, and both differential output terminals of the differential transmission unit **109** drive their respectively adapted loads **[120] 120b1, 120b2**.

As required by the construction, the planetary gear set **801**, the first dynamo-electrical unit **101**, the brake **902**, the brake **901**, and the clutch **132** may be incorporated to the first drive system **1001**, or to the second drive system **1002** or provided standing alone.

In the system respectively illustrated in FIGS. **43** and **44**, while driving the pilot drive unit **1000**, the operation of the active rotational power source **100** may further drive the first dynamo-electrical unit **101** by the active rotational power source **100** to operate as a generator with the power generated to drive two or multiple second dynamo-electrical units **[103] 103b, 103c** in the second drive system **1002** to produce the rotational kinetic energy to drive the load **[120] 120b1, 120b2** for the system to provide the serial hybrid power transmission.

When the rechargeable device **106** is provided to the system, the active rotational power source **100** drives the first dynamo-electrical unit **101** to operate as a generator with the power generated to recharge the rechargeable device **106** or supply power to any other electrical power driven load **130** (including any externally connected unspecified load), and drive two or multiple second dynamo-electrical units **[103] 103b, 103c** in the second drive system **1002** to produce rotational kinetic energy for driving the load **[120] 120b1, 120b2**.

When the system is provided with the rechargeable device **106**, the active rotational power source **100** drives the first dynamo-electrical unit **101** to operate as a generator with the power generated to recharge the rechargeable device **106** or to supply power to other electrical power driven load **130** (including any externally connected unspecified load).

When the first dynamo-electrical unit **101** operates as a generator, the generated power and power from the rechargeable device **106** jointly drive the second dynamo-electrical unit **103** to produce the rotational kinetic energy to drive the load **[120] 120a1, 120a2** or supply power to any other electrical power driven load **130** (including any externally connected unspecified load).

The power from the rechargeable device **106** drives alone the second dynamo-electrical unit **103** in the second drive system **1002** to produce the rotational kinetic energy for driving the load; or the rotational kinetic energy produced by the second dynamo-electrical unit **103** in the second drive system **1002** as driven by the power from the rechargeable device **106** jointly drive the load **[120] 120b1, 120b2** with the power from the active rotational power source **100**.

The regenerated power of feedback braking regeneration by the first dynamo-electrical unit **101** or the second dynamo-electrical unit **103** recharges the rechargeable device **106** or supply power to any other electrical power driven load **130** (including any externally connected unspecified load); or the

transmission status of the rotational kinetic energy between the first drive system **1001** and the second drive system **1002** is controlled by switching the clutch **132** to engage or disengage state for the system to operating with those System Functions 1 through 80.

FIG. **45** is the twelfth block diagram showing that a pilot drive unit is provided to the output terminal of the active rotational power source of the present invention. The preferred embodiment illustrated in FIG. **45** is comprised of the first drive system **1001** and the second drive system **1002**. The construction of the first drive system **1001** includes the pilot drive unit **1000** comprised with the output shaft of the active rotational power source **100** coupled to the additionally provided transmission unit **129**, and further to the auxiliary clutch **1020** and the optionally provided transmission unit **[109] 109a** of the prior art to drive the load **[120] 120a1, 120a2**, and the active rotational power source **100**.

The input terminal of the clutch **1020** in the pilot drive unit **1000** is coupled to the output terminal of the transmission unit **129** driven by the active rotational power source **100**, or to another output terminal of the active rotational power source **100**. The transmission unit **[109] 109a** coupled between the clutch **1020** and the load **[120] 120a1, 120a2** may be comprised of the transmission unit **[109] 109a** which provides the capability of controllable multistage transmission, continuously variable transmission, reversing or idling function, or may be comprised of the transmission unit **[109] 109a** which provides the capability of controllable multistage transmission, continuously variable transmission, reversing or idling function and multiple shafts for the operation of differential output to drive the loads **[120] 120a1, 120a2** respectively adapted to each differential output terminal for differential operation.

Another output terminal of the transmission unit **129** is provided to drive the planet gear **803** of the planetary gear set **801**. The rotary part of the first dynamo-electrical unit **101** is coupled to the sun gear **802** of the planetary gear set **801**. The operation between the rotary part and the stationary part of the first dynamo-electrical unit **101** as required may function as a motor under the regulation of the drive control unit **104** to output the rotational kinetic energy, or as a generator to produce damping while generating the power for the damping to make the rotational kinetic energy from the active rotational power source **100** to be transferred from the external gear **804**, or under the regulation of the drive control unit **104** for electromagnetic lock up operation between the stationary part and the rotary part of the first dynamo-electrical unit **101**. As required, the EM lockup function may be replaced by the brake **902** with the rotary part of the first dynamo-electrical unit **101** coupled to the rotation side of the brake **902** and the stationary part of the brake **902** locked to the frame or to the stationary part of the first dynamo-electrical unit **101** for locking up the first dynamo-electrical unit **101** and routing the rotational kinetic energy from the active rotational power source **100** to be transferred through the external gear **804**.

To compromise the operation of the system, the brake **901** is required for the active rotational power source **100** to drive the first dynamo-electrical unit **101** to operate as a generator. The external gear **804** of the planetary gear set **801** is coupled to the input terminal of the clutch **112** and coupled to the rotation side of the brake **901**; the stationary part of the brake **901** is locked to the frame; and another end of the clutch **132** is coupled to the rotary part of the second dynamo-electrical unit **[103] 103b, 103c** in the second drive system **1002**, or to the input terminal of the optionally provided transmission unit **[109] 109e** in the second drive system **1002**. The optionally provided clutch **132** regulates the transmission of the



61

rotational kinetic energy between the first drive unit **1001** and the second drive unit **1002** while the clutch **132** and the brake **901** may be split installed or share common structure.

The second drive system **1002** as illustrated in FIG. **45** is comprised of multiple second dynamo-electrical units **[103]** *103b*, *103c* serving as the power source respectively coupled to the optionally provided transmission unit **[109]** *109e* or any other transmission device their respectively coupled loads **[120]** *120b1*, *120b2*.

As required by the construction, the planetary gear set **801**, the first dynamo-electrical unit **101**, the brake **902**, the brake **901**, and the clutch **132** may be incorporated to the first drive system **1001**, or to the second drive system **1002** or provide standalone operation.

In the system respectively illustrated in FIG. **45**, while driving the pilot drive unit **1000**, with the clutch **132** disengaged, the operation of the active rotational power source **100** may further drive the first dynamo-electrical unit **101** by the active rotational power source **100** to operate as a generator with the power generated to drive two or multiple second dynamo-electrical units **[103]** *103b*, *103c* in the second drive system **1002** to produce the rotational kinetic energy to drive the load **[120]** *120b1*, *120b2* for the system to provide the serial hybrid power transmission.

When the rechargeable device **106** is provided to the system, the active rotational power source **100** drives the first dynamo-electrical unit **101** to operate as a generator with the power generated to recharge the rechargeable device **106** or supply power to any other electrical power driven load **130** (including any externally connected unspecified load), and drive two or multiple second dynamo-electrical units **[103]** *103b*, *103c* in the second drive system **1002** to produce rotational kinetic energy for driving the load **[120]** *120b1*, *120b2*.

When the system is provided with the rechargeable device **106**, the active rotational power source **100** drives the first dynamo-electrical unit **101** to operate as a generator with the generated power to recharge the rechargeable device **106** or to supply power to other electrical power driven load **130** (including any externally connected unspecified load).

When the first dynamo-electrical unit **101** operates as a generator, the generated power and power from the rechargeable device **106** jointly drive the second dynamo-electrical unit **[103]** *103b*, *103c* to produce the rotational kinetic energy to drive the load **[120]** *120b1*, *120b2* or supply power to any other electrical power driven load **130** (including any externally connected unspecified load).

The power from the rechargeable device **106** drives alone the second dynamo-electrical unit **[103]** *103b*, *103c* in the second drive system **1002** to produce the rotational kinetic energy for driving the load **[120]** *120b1*, *120b2*; or the rotational kinetic energy produced by the second dynamo-electrical unit **[103]** *103b*, *103c* in the second drive system **1002** as driven by the power from the rechargeable device **106** jointly drive the load **[120]** *120b1*, *120b2* with the power from the active rotational power source **100**.

The regenerated power of feedback braking regeneration by the first dynamo-electrical unit **101** or the second dynamo-electrical unit **[103]** *103b*, *103c* recharges the rechargeable device **106** or supply power to any other electrical power driven load **130** (including any externally connected unspecified load); or the transmission status of the rotational kinetic energy between the first drive system **1001** and the second drive system **1002** is controlled by switching the clutch **132** to engaged or disengage to perform System Functions 1 through 80.

FIG. **46** is the thirteenth block diagram showing that a pilot drive unit is provided to the output terminal of the active

62

rotational power source of the present invention; and FIG. **47** is the fourteenth block diagram showing that a pilot drive unit is provided to the output terminal of the active rotational power source of the present invention. Both preferred embodiments respectively illustrated in FIGS. **46** and **47** are each comprised of the first drive system **1001** and the second drive system **1002**. The construction of the first drive system **1001** includes the pilot drive unit **1000** comprised with the output shaft of the active rotational power source **100** coupled to the additionally provided transmission unit **129**, and further to the auxiliary clutch **1020** and the optionally provided transmission unit **[109]** *109a* of the prior art to drive the load **[120]** *120a1*, *120a2*, and the active rotational power source **100**.

The input terminal of the clutch **1020** in the pilot drive unit **1000** is coupled to the output terminal of the transmission unit **129** driven by the active rotational power source **100**, or to another output terminal of the active rotational power source **100**. The transmission unit **[109]** *109a* coupled between the clutch **1020** and the load **[120]** *120a1*, *120a2* may be comprised of the transmission unit **[109]** *109a* which provides the capability of controllable multistage transmission, continuously variable transmission, reversing or idling function as illustrated in FIG. **46** or may be comprised of the transmission unit **[109]** *109a* which provides the capability of controllable multistage transmission, continuously variable transmission, reversing or idling function and multiple shafts for the operation of differential output to drive the loads **[120]** *120a1*, *120a2* respectively adapted to each differential output terminal for executing the differential operation as illustrated in FIG. **47**.

Among the three input and output terminals of the rotational gear set **1030**, the first input and output terminal **501** is coupled to the first input and output gear set **511**, and to another output terminal of the additionally provided transmission unit **129**. The second input and output terminal **502** is coupled to the first dynamo-electrical unit **101**, the brake **902** and the second input and output gear set **512**. Both of the first and the second input and output gear sets **511**, **512** are coupled to the differential gear set **5130** for a rotary arm **5131** to draw the differential output gear set **5132** and the third input and output gear set **513** for the third input and output gear set **513** to drive the third input and output terminal **503** and the rotary part of the brake **901** and the input terminal of the clutch **132**. The stationary part of the brake **901** is locked to the frame and another end of the clutch **132** is coupled to the rotary part of the second dynamo-electrical unit **103** adapted to the second drive system **1002**, or to the input terminal of the optionally provided transmission unit **109**. The optionally provided clutch **132** regulates the transmission of the rotational kinetic energy between the first drive system **1001** and the second drive system **1002**. The clutch **132** and the brake **901** may be split installed or share the common structure.

The second drive system **1002** is comprised with the second dynamo-electrical unit **103** as the power source as illustrated in FIG. **46** to be coupled to the optionally provided transmission unit **[109]** *109f* or any other transmission device to drive one or multiple load **[120]** *120b1*, *120b2*; or as illustrated in FIG. **47**, with the rotary part of the optionally provided second dynamo-electrical unit **103** to be coupled to the input terminal of the differential transmission unit **[109]** *109f* for both differential output terminals of the differential transmission unit **[109]** *109f* to drive their respectively adapted loads **[120]** *120b1*, *120b2*.

As required by the construction, the rotational gear set **1030**, the first dynamo-electrical unit **101**, the brake **902**, the brake **901**, and the clutch **132** may be incorporated to the first

drive system **1001**, or to the second drive system **1002** or providing standalone operation.

In the system respectively illustrated in FIGS. **46** and **47**, while driving the pilot drive unit **1000**, the operation of the active rotational power source **100** may further drive the first dynamo-electrical unit **101** by the active rotational power source **100** to operate as a generator with the power generated to drive two or multiple second dynamo-electrical units **103** in the second drive system **1002** to produce the rotational kinetic energy to drive the load **[120]** *120b1*, *120b2* for the system to provide the serial hybrid power transmission.

When the rechargeable device **106** is provided to the system, the active rotational power source **100** drives the first dynamo-electrical unit **101** to operate as a generator with the power generated to recharge the rechargeable device **106** or supply power to any other electrical power driven load **130** (including any externally connected unspecified load), and drive two or multiple second dynamo-electrical units **103** in the second drive system **1002** to produce rotational kinetic energy for driving the load **[120]** *120b1*, *120b2*.

When the system is provided with the rechargeable device **106**, the active rotational power source **100** drives the first dynamo-electrical unit **101** to operate as a generator with the power generated to recharge the rechargeable device **106** or to supply power to other electrical power driven load **130** (including any externally connected unspecified load).

When the first dynamo-electrical unit **101** operates as a generator, the generated power and power from the rechargeable device **106** jointly drive the second dynamo-electrical unit **103** to produce the rotational kinetic energy to drive the load **[120]** *120b1*, *120b2* or supply power to any other electrical power driven load **130** (including any externally connected unspecified load).

The power from the rechargeable device **106** drives alone the second dynamo-electrical unit **103** in the second drive system **1002** to produce the rotational kinetic energy for driving the load; or the rotational kinetic energy produced by the second dynamo-electrical unit **103** in the second drive system **1002** as driven by the power from the rechargeable device **106** jointly drive the load with the power from the active rotational power source **100**.

The regenerated power of feedback braking regeneration by the first dynamo-electrical unit **101** or the second dynamo-electrical unit **103** recharges the rechargeable device **106** or supply power to any other electrical power driven load **130** (including any externally connected unspecified load); or the transmission status of the rotational kinetic energy between the first drive system **1001** and the second drive system **1002** is regulated by switching the clutch **132** between engage or disengage to perform System Functions 1 through 80.

FIG. **48** is the fifteenth block diagram showing that a pilot drive unit is provided to the output terminal of the active rotational power source of the present invention. The preferred embodiment illustrated in FIG. **48** is comprised of the first drive system **1001** and the second drive system **1002**. The construction of the first drive system **1001** includes the pilot drive unit **1000** comprised with the output shaft of the active rotational power source **100** coupled to the additionally provided transmission unit **129**, and further to the auxiliary clutch **1020** and the optionally provided transmission unit **[109]** *109a* of the prior art to drive the load **[120]** *120a1*, *120a2*, and the active rotational power source **100**.

The input terminal of the clutch **1020** in the pilot drive unit **1000** is coupled to the output terminal of the transmission unit **129** driven by the active rotational power source **100**, or to another output terminal of the active rotational power source **100**. The transmission unit **[109]** *109a* coupled between the

clutch **1020** and the load **[120]** *120a1*, *120a2* may be comprised of the transmission unit **[109]** *109a* which provides the capability of controllable multistage transmission, continuously variable transmission, reversing or idling function or may be comprised of the transmission unit **[109]** *109a* which provides the capability of controllable multistage transmission, continuously variable transmission, reversing or idling function and multiple shafts for the operation of differential output to drive the loads **[120]** *120a1*, *120a2* respectively adapted to each differential output terminal for differential operation

Among the three input and output terminals of the rotational gear set **1030**, the first input and output terminal **501** is coupled to the first input and output gear set **511**, and to another output terminal of the additionally provided transmission unit **129**. The second input and output terminal **502** is coupled to the first dynamo-electrical unit **101**, the brake **902** and the second input and output gear set **512**. Both of the first and the second input and output gear sets **511**, **512** are coupled to the differential gear set **5130** for a rotary arm **5131** to draw the differential output gear set **5132** and the third input and output gear set **513** for the third input and output gear set **513** to drive the third input and output terminal **503** and the rotary part of the brake **901** and the input terminal of the clutch **132**. The stationary part of the brake **901** is locked to the frame and another end of the clutch **132** is coupled to the rotary part of the second dynamo-electrical unit **103** adapted to the second drive system **1002**, or to the input terminal of the optionally provided transmission unit **109**. The optionally provided clutch **132** controls the transmission of the rotational kinetic energy between the first drive system **1001** and the second drive system **1002**. The clutch **132** and the brake **901** may be split installed or share common structure.

The second drive system **1002** with multiple second dynamo-electrical units **[103]** *103b*, *103c* as the power source is coupled to the individual optionally provided transmission unit **[109]** *109e* or any other transmission device for driving their respectively adapted loads **[120]** *120b1*, *120b2*.

The rotational gear set **1030**, the first dynamo-electrical unit **101**, the brake **902**, the brake **901**, and the clutch **132** may be incorporated to the first drive system **1001**, or to the second drive system **1002** or providing standalone operation as required.

In the system illustrated in FIG. **48**, while driving the pilot drive unit **1000**, the primary operation of the active rotational power source **100** with the clutch **132** is disengaged may further drive the first dynamo-electrical unit **101** by the active rotational power source **100** to operate as a generator with the power generated to drive two or multiple second dynamo-electrical units **[103]** *103b*, *103c* in the second drive system **1002** to generate the rotational kinetic energy to drive the load **[120]** *120b1*, *120b2* for the system to provide the serial hybrid power transmission.

When the rechargeable device **106** is provided to the system, the active rotational power source **100** drives the first dynamo-electrical unit **101** to operate as a generator with the power generated to recharge the rechargeable device **106** or supply power to any other electrical power driven load **130** (including any externally connected unspecified load), and drive two or multiple second dynamo-electrical units **[103]** *103b*, *103c* in the second drive system **1002** to produce rotational kinetic energy for driving the load **[120]** *120b1*, *120b2*.

When the system is provided with the rechargeable device **106**, the active rotational power source **100** drives the first dynamo-electrical unit **101** to operate as a generator with the power generated to recharge the rechargeable device **106** or to

supply power to other electrical power driven load **130** (including any externally connected unspecified load).

When the first dynamo-electrical unit **101** operates as a generator, the generated power and power from the rechargeable device **106** jointly drive the second dynamo-electrical unit **[103] 103b, 103c** to produce the rotational kinetic energy to drive the load **[120] 120b1, 120b2** or supply power to any other electrical power driven load **130** (including any externally connected unspecified load).

The power from the rechargeable device **106** drives alone the second dynamo-electrical unit **[103] 103b, 103c** in the second drive system **1002** to produce the rotational kinetic energy for driving the load **[120] 120b1, 120b2**; or the rotational kinetic energy produced by the second dynamo-electrical unit **[103] 103b, 103c** in the second drive system **1002** as driven by the power from the rechargeable device **106** drive the load **[120] 120b1, 120b2** jointly with the power from the active rotational power source **100**.

The regenerated power of feedback braking regeneration by the first dynamo-electrical unit **101** or the second dynamo-electrical unit **[103] 103b, 103c** recharges the rechargeable device **106** or supply power to any other electrical power driven load **130** (including any externally connected unspecified load); or the transmission status of the rotational kinetic energy between the first drive system **1001** and the second drive system **1002** is regulated by switching the clutch **132** to engaged or disengaged status to perform the System Functions 1 through 80.

FIG. **49** is the sixteenth block diagram showing that a pilot drive unit is provided to the output terminal of the active rotational power source of the present invention; and FIG. **50** is the seventeenth block diagram showing that a pilot drive unit is provided to the output terminal of the active rotational power source of the present invention. Both preferred embodiments respectively illustrated in FIGS. **49** and **50** are each comprised of the first drive system **1001** and the second drive system **1002**. The construction of the first drive system **1001** includes the pilot drive unit **1000** comprised with the output shaft of the active rotational power source **100** coupled to the additionally provided transmission unit **129**, and further to the auxiliary clutch **1020** and the optionally provided transmission unit **[109] 109a** of the prior art to drive the load **[120] 120a1, 120a2**, and the active rotational power source **100**.

The input terminal of the clutch **1020** in the pilot drive unit **1000** is coupled to the output terminal of the transmission unit **129** driven by the active rotational power source **100**, or to another output terminal of the active rotational power source **100**. The transmission unit **[109] 109a** coupled between the clutch **1020** and the load **[120] 120a1, 120a2** may be comprised of the transmission unit **[109] 109a** which provides the capability of controllable multistage transmission, continuously variable transmission, reversing or idling function or may be comprised of the transmission unit **[109] 109a** which provides the capability of controllable multistage transmission, continuously variable transmission, reversing or idling function and multiple shafts for the operation of differential output to drive the loads **[120] 120a1, 120a2** respectively adapted to each differential output terminal for differential operation.

Another output terminal of the transmission unit **129** drives the optionally provided clutch **102** and the transmission unit **[109] 109b** coupled to the transmission unit **129** for driving the rotary part of the first dynamo-electrical unit **101**. In the first drive system **1001**, a dual motion dynamo-electrical unit **1040** made in the form of AC or DC, brush or brushless, synchronous or asynchronous is provided. The dual motion

dynamo-electrical unit **1040** made in a cylinder, disk or cone shape is comprised of a first rotary part **1041** and a second rotary part **1042** with a controllable clutch **122** installed between the first and the second rotary parts **1041, 1042**. The first rotary part **1041** is coupled to that of the brake **901**, and further to that of the first dynamo-electrical unit **101** through the clutch **112**. The stationary part of the brake **901** is locked to the frame. The second rotary part **1042** of the dual motion dynamo-electrical unit **1040** is coupled to the input terminal of the clutch **132** and another end of the clutch **132** is coupled to the rotary part of the second dynamo-electrical unit **103** adapted to the second drive system **1002**, or coupled to the input terminal of the optionally provided transmission unit **[109] 109f** adapted to the second drive system **1002**. The clutch **132** is provided for the control of the transmission of the rotational kinetic energy between the first drive system **1001** and the second drive system **1002**.

The second drive system **1002** is comprised with the second dynamo-electrical unit **103** as the power source as illustrated in FIG. **49** to be coupled to the optionally provided transmission unit **[109] 109f** or any other transmission device to drive one or multiple load **[120] 120b1, 120b2**; or as illustrated in FIG. **50**, having the rotary part of the optionally provided second dynamo-electrical unit **103** to be coupled to the input terminal of the differential transmission unit **[109] 109f** for both differential output terminals of the differential transmission unit **[109] 109f** to drive their respectively adapted loads **[120] 120b1, 120b2**.

As required by the construction, the clutch **102**, the transmission unit **[109] 109b**, the first dynamo-electrical unit **101**, the clutch **112**, the brake **901**, the dual motion dynamo-electrical unit **1040**, the clutch **122**, and the clutch **132** may be incorporated to the first drive system **1001**, or to the second drive system **1002** or providing standalone operation.

In the system respectively illustrated in FIGS. **49** and **50**, while driving the pilot drive unit **1000**, the operation of the active rotational power source **100** may further drive the first dynamo-electrical unit **101** by the active rotational power source **100** to operate as a generator with the power generated to drive two or multiple second dynamo-electrical units **103** in the second drive system **1002** to produce the rotational kinetic energy to drive the load **[120] 120a1, 120a2** for the system to provide the serial hybrid power transmission.

When the rechargeable device **106** is provided to the system, the active rotational power source **100** drives the first dynamo-electrical unit **101** to operate as a generator to recharge the rechargeable device **106** or supply power to any other electrical power driven load **130** (including any externally connected unspecified load), and drive two or multiple second dynamo-electrical units **103** in the second drive system **1002** to produce rotational kinetic energy for driving the load **[120] 120b1, 120b2**.

When the system is provided with the rechargeable device **106**, the active rotational power source **100** drives the first dynamo-electrical unit **101** to operate as a generator with the power generated to recharge the rechargeable device **106** or to supply power to other electrical power driven load **130** (including any externally connected unspecified load).

When the first dynamo-electrical unit **101** operates as a generator, the power generated and that from the rechargeable device **106** jointly drive the second dynamo-electrical unit **103** to produce the rotational kinetic energy to drive the load **[120] 120b1, 120b2** or supply power to any other electrical power driven load **130** (including any externally connected unspecified load).

The power from the rechargeable device **106** drives alone the second dynamo-electrical unit **103** in the second drive

system **1002** to produce the rotational kinetic energy for driving the load; or the rotational kinetic energy produced by the second dynamo-electrical unit **103** in the second drive system **1002** as driven by the power from the rechargeable device **106** drive the load jointly with the power from the active rotational power source **100**.

The regenerated power of feedback braking regeneration by the first dynamo-electrical unit **101** or the second dynamo-electrical unit **103** recharges the rechargeable device **106** or supply power to any other electrical power driven load **130** (including any externally connected unspecified load); or the transmission status of the rotational kinetic energy between the first drive system **1001** and the second drive system **1002** is regulated by switching the clutch **132** to be engaged or disengaged status to operate in System Functions 1 through 80.

FIG. **51** is the eighteenth block diagram showing that a pilot drive unit is provided to the output terminal of the active rotational power source of the present invention. The preferred embodiment illustrated in FIG. **51** is comprised of the first drive system **1001** and the second drive system **1002**. The construction of the first drive system **1001** includes the pilot drive unit **1000** comprised with the output shaft of the active rotational power source **100** coupled to the additionally provided transmission unit **129**, and further to the auxiliary clutch **1020** and the optionally provided transmission unit **[109] 109a** of the prior art to drive the load **[120] 120a1, 120a2**, and the active rotational power source **100**.

The input terminal of the clutch **1020** in the pilot drive unit **1000** is coupled to the output terminal of the transmission unit **129** driven by the active rotational power source **100**, or to another output terminal of the active rotational power source **100**. The transmission unit **[109] 109a** coupled at where between the clutch **1020** and the load **[120] 120a1, 120a2** may be comprised of the transmission unit **[109] 109a** which provides the capability of controllable multistage transmission, continuously variable transmission, reversing or idling function or may be comprised of the transmission unit **[109] 109a** which provides the capability of controllable multistage transmission, continuously variable transmission, reversing or idling function and multiple shafts for the operation of differential output to drive the loads **[120] 120a1, 120a2** respectively adapted to each differential output terminal for differential operation.

Another output terminal of the transmission unit **129** drives the optionally provided clutch **102** and the transmission unit **[109] 109c** coupled to the transmission unit **129** for driving the rotary part of the first dynamo-electrical unit **101**. In the first drive system **1001**, a dual motion dynamo-electrical unit **1040** made in the form of AC or DC, brush or brushless, synchronous or asynchronous is provided. The dual motion dynamo-electric unit **1040** made in a cylinder, disk or cone shape is comprised of a first rotary part **1041** and a second rotary part **1042** with a controllable clutch **122** installed between the first and the second rotary parts **1041, 1042**. The first rotary part **1041** is coupled to that of the brake **901**, and further to that of the first dynamo-electrical unit **101** through the clutch **112**. The stationary part of the brake **901** is locked to the frame. The second rotary part **1042** of the dual motion dynamo-electrical unit **1040** is coupled to the input terminal of the clutch **132** and another end of the clutch **132** is coupled to the rotary part of the second dynamo-electrical unit **103** adapted to the second drive system **1002**, or coupled to the input terminal of the optionally provided transmission unit **109** adapted to the second drive system **1002**. The clutch **132**

is provided for the control of the transmission of the rotational kinetic energy between the first drive system **1001** and the second drive system **1002**.

The second drive system **1002** is comprised with multiple second dynamo-electrical units **[103] 103b, 103c** as the power source respectively coupled to the optionally provided transmission unit **[109] 109e** or any other transmission device to drive one or multiple load **[120] 120b1, 120b2**.

As required by the construction, the clutch **102**, the transmission unit **109**, the first dynamo-electrical unit **101**, the clutch **112**, the brake **901**, the dual motion dynamo-electrical unit **1040**, the clutch **122**, and the clutch **132** may be incorporated to the first drive system **1001**, or to the second drive system **1002** or providing standalone operation.

In the system illustrated in FIG. **51**, while driving the pilot drive unit **1000** with the clutch **132** disengaged, the operation of the active rotational power source **100** may further drive the first dynamo-electrical unit **101** by the active rotational power source **100** to operate as a generator with the power generated to drive two or multiple second dynamo-electrical units **[103] 103b, 103c** in the second drive system **1002** to produce the rotational kinetic energy to drive the load **[120] 120b1, 120b2** for the system to provide the serial hybrid power transmission.

When the rechargeable device **106** is provided to the system, the active rotational power source **100** drives the first dynamo-electrical unit **101** to operate as a generator with the power generated to recharge the rechargeable device **106** or supply power to any other electrical power driven load **130** (including any externally connected unspecified load), and drive two or multiple second dynamo-electrical units **[103] 103b, 103c** in the second drive system **1002** to produce rotational kinetic energy for driving the load **[120] 120b1, 120b2**.

When the system is provided with the rechargeable device **106**, the active rotational power source **100** drives the first dynamo-electrical unit **101** to operate as a generator to recharge the rechargeable device **106** or to supply power to other electrical power driven load **130** (including any externally connected unspecified load).

When the first dynamo-electrical unit **101** operates as a generator, the power generated and that from the rechargeable device **106** jointly drive the second dynamo-electrical unit **[103] 103b, 103c** to produce the rotational kinetic energy to drive the load **[120] 120b1, 120b2** or supply power to any other electrical power driven load **130** (including any externally connected unspecified load).

The power from the rechargeable device **106** drives alone the second dynamo-electrical unit **[103] 103b, 103c** in the second drive system **1002** to produce the rotational kinetic energy for driving the load **[120] 120b1, 120b2**; or the rotational kinetic energy produced by the second dynamo-electrical unit **[103] 103b, 103c** in the second drive system **1002** as driven by the power from the rechargeable device **106** drive the load **[120] 120b1, 120b2** jointly with the power from the active rotational power source **100**.

The regenerated power of feedback braking regeneration by the first dynamo-electrical unit **101** or the second dynamo-electrical unit **[103] 103b, 103c** recharges the rechargeable device **106** or supply power to any other electrical power driven load **130** (including any externally connected unspecified load); or the transmission status of the rotational kinetic energy between the first drive system **1001** and the second drive system **1002** is regulated by switching the clutch **132** to be engaged or disengaged status to operate in System Functions 1 through 80.

Those preferred embodiments of the split serial-parallel hybrid dual-power drive system illustrated in FIGS. **1** through

51 provide partial or all those functions described in System Functions 1 through 80. When the system is provided with multiple second drive systems **1002**, a clutch **132** may be optionally provided between any two second drive systems **1002** as required by the application for the control of the transmission of the rotational kinetic energy. The clutch **132** may be comprised of one that operates by manual, mechanical force, eccentric force, air pressure, or hydraulic pressure, or electromagnetic force, or a single way clutch to transmit or interrupt the transmission of the mechanical rotational kinetic energy so that when the clutch **132** is engaged, it allows the incorporation of the drive units provided at its both ends; or when disengaged, individual operation of both drive units provided at its both ends. Furthermore, for the split serial-parallel hybrid dual-power drive system, one or multiple first drive system **1001**, and one or multiple second drive system **1002** may be provided as required by the system.

Accordingly, the split serial-parallel hybrid dual-power drive system is innovative in that it may be controlled to provide the serial hybrid power drive operation or the parallel hybrid power drive operation; and provide the serial hybrid power drive operation or the parallel hybrid power drive operation between both independently provided first and second drive systems. Furthermore, a controllable clutch is provided to control the status of mutual transmission of the rotational kinetic energy between two units for the system to give more types of drive features depending on the load to be driven.

Furthermore, in order to reduce the friction loss from off-lined first dynamo-electrical unit **101** or off-lined second dynamo-electrical unit **103**, the structure of those preferred embodiments of present invention: "The separated series-parallel hybrid twin-power driving system", is identical as prior art, which further equipped with clutch **102**, **112**, **122** or **132** and the transmission unit **119**, or transmission unit **129**, or speed-variable transmission unit **109**, between the shaft of electrical machinery and the engine-driven shaft. While the function of first dynamo-electrical unit **101** or second dynamo-electrical unit **103** is not required, by disengaging the clutch **102**, **112**, **122** or **132**, the first dynamo-electrical unit **101** or second dynamo-electrical unit **103** could be isolated without influencing the driving operation of system.

The split serial-parallel hybrid dual-power drive system allowing the operation in the better brake specific fuel consumption (BSFC) status when applied in lower power output, such as in a car driving in downtown area, to correct the defectives of lower efficiency and higher pollution found with the internal combustion engine running at lower rpm or for a light load provides specific innovative functions. Therefore this application for a patent is duly filed accordingly.

What is claimed is:

1. A split serial-parallel hybrid dual-power drive system, more particularly a drive system configured to drive a load by employing rotational kinetic energy;

the split serial-parallel hybrid dual-power drive system comprising two or more drive systems [each configured to independently drive the load] incorporated in a common frame that is driven by the kinetic energy of at least one drive system;

the dual-power drive system including a first drive system and a second drive system;

the first drive system including an active power source, a first dynamo-electrical unit functioning as a generator, a second dynamo-electrical unit functioning as a motor, and a first clutch driven by a drive control unit to control the active rotational power source to output transmission status of the rotational kinetic energy;

the second drive system including a third dynamo-electrical unit functioning as a motor to serve as a rotational power source for the second drive system;

a fourth clutch configured to control mutual transmission [or] and cut-off of the rotational kinetic energy between the first and second drive systems;

by means of the control and operation of a control system or manually, either;

the active rotational power source and the first dynamo-electrical unit of the [separation] serial-parallel hybrid drive system are coupled through the first clutch, and the first dynamo-electrical unit and the second dynamo-electrical unit are separated; and the active rotational kinetic energy source drives the first dynamo-electrical unit to output electric power to further drive the second dynamo-electrical unit to operate as a motor to [provide functions related to] function as a series hybrid power train;

or through the control and operation of the first clutch, the rotational kinetic energy from the active rotational power source outputs rotational kinetic energy to drive either or both of a first load of the first drive system and a second load of the second drive system, where the second load is driven through the fourth clutch;

or the active rotational power source is coupled to at least one of the first and the second dynamo-electrical units, and a rechargeable device to [provide functions related to] function as a parallel hybrid power train;

the split serial-parallel hybrid dual-power drive system essentially comprised of the active rotational power source, first clutch, [the] first and second dynamo-electrical units, second clutch, fourth clutch, drive control unit, central control unit, rechargeable device, auxiliary rechargeable device, and load as follows:

the active rotational power source (**100**), comprising at least one of an internal combustion engine and an external combustion engine, is a rotational kinetic energy power source; a rotary part of the active rotational source selectively either directly coupled to the first dynamo-electrical unit (**101**) or indirectly coupled to the rotary part of the first dynamo-electrical unit (**101**) through a first transmission unit ([**109**] *109a*), a second transmission unit (**129**), [or] and the first clutch (**102**);

the first dynamo-electrical unit (**101**) is configured to be switched to operate as a generator or a motor; when the second dynamo-electrical unit (**103**) is connected to the first drive system (**1001**), the rotary part of the first dynamo-electrical unit (**101**) is coupled to the second dynamo-electrical unit (**103**) through the second clutch (**112**);

the second dynamo-electrical unit (**103**) is configured to be switched to operate as a generator or a motor to become the rotational power source for the second drive system (**1002**); the output terminal of the rotary part of the second dynamo-electrical unit (**103**) directly outputs the rotational kinetic energy to drive the second load or outputs the rotational kinetic energy to drive the second load through the third clutch (**122**);

the input terminal of the second dynamo-electrical unit (**103**) in the second drive system is coupled to a fourth clutch (**132**);

the first clutch (**102**) is a transmission device that transmits or interrupts the rotational kinetic energy and is configured to be coupled to between the rotary part of the active rotational power source (**100**) and the first dynamo-electrical unit (**101**) as [required] controlled by the drive control unit;

the second clutch (112) transmits or interrupts the rotational kinetic energy and is coupled between the second dynamo-electrical unit (103) and the first dynamo-electrical unit (101);

the third clutch (122) transmits or interrupts the rotational kinetic energy and is coupled between the input terminal of the *second* load ([120] 120b) of the [first] *second* drive system and the rotary part of the second dynamo-electrical unit ([103] 103a) of the [first] *second* drive system[;], as [required] *controlled by the drive control unit*;

the fourth clutch (132) transmits or interrupts the rotational kinetic energy and is coupled between the rotary part of the active rotational power source (100) and the rotary part of the second dynamo-electrical unit (103) of the second drive system (1002) to control whether the rotational kinetic energy between the first and the second drive systems (1001, 1002) is to be transmitted or interrupted;

the drive control unit (104) includes a circuit configured to provide [any or all] *at least one of* the following functions:

for the system to operate as a series hybrid power system;

when the first dynamo-electrical unit (101) in the first drive system (1001) operates as a generator, the drive control unit (104) controls the power outputted to drive the second dynamo-electrical unit (103) of the second drive system (1002), and/or recharge the main rechargeable device (106);

*the drive control unit* controls the power from the main rechargeable device (106) to drive the first and the second dynamo-electrical units (101, 103) each operating as a motor;

when subject to the drive control unit (104), the first dynamo-electrical unit (101) in the first drive system (1001) and the second dynamo-electrical unit (103) in the second drive system (1002), or any part of those dynamo-electrical units therein is inversely driven to operate as a generator to control the recharging power outputted to the main rechargeable device (106) or power supplied to other load for the dynamo-electrical unit to [operate for breaking] *produce a braking* function by regenerated power;

the central control unit (105) is subject to a control interface (107) to control the operation of the split serial-parallel hybrid dual-power drive system, [particularly to the] *for* optimal fuel consumption [of] *and* pollution control, [i.e.] the optimal brake specific fuel consumption [generally] applicable to the system either operating as series or parallel hybrid power train by [having] *operating* the engine [to operate] in a range of rpm that consumes less fuel yet outputs [higher] power [efficiency] *more efficiently*; the central control unit (105) [by having] *operating* the drive control unit (104) to control the operation of [relative functions among] the first dynamo-electrical unit (101) in the first drive system (1001), the second dynamo-electrical unit (103) in the second drive system (1002), and the main rechargeable device (106), and [controls the] *operates the drive control unit to control* feedback [monitor] *monitoring* and interaction [among various] *between the* units in the system;

the control interface (107) is configured to receive inputs manually or by control signals to control the operation of the [separation] serial-parallel dual-power system;

the auxiliary rechargeable device (110) is controlled by a startup switch (111) to drive a startup motor (121)

adapted to drive an engine serving as the active rotational power source (100) thus to supply power to an auxiliary load (130);

the auxiliary load (130) is selectively driven by the generated power from the first dynamo-electrical unit (101) or the second dynamo-electrical unit (103) operating as a generator, or by the power from the main rechargeable device (106) or the auxiliary rechargeable device (110) to output the rotational kinetic energy with the engine as the active rotational power source, the split serial-parallel hybrid dual-power drive system [provides any or all] *providing at least one of* the following functions:

the rotational kinetic energy from the engine power drives a first load ([120] 120a) of the first drive system (1001) and/or a second load ([120] 120b) of the second drive system (1002);

when the system is operating as a series hybrid power train, the engine is controlled to run from lower rpm up to higher rpm, or at a preset rpm to drive the first dynamo-electrical unit (101) in the first drive system (1001) to operate as a generator;

in case of a light load, the power generated by the first dynamo-electrical unit (101) in the first drive system (1001) drives the second dynamo-electrical unit (103) in the second drive system (1002) while recharging the main rechargeable device (106) at the same time; and

in case of a heavy load,

*either* the power generated by the first dynamo-electrical unit (101) in the first drive system (1001) and that from the main rechargeable device (106) jointly drive the second dynamo-electrical unit (103) of the second drive system (1002) for outputting the rotational kinetic energy to drive the second load ([120] 120b) to control the engine to run [at a fixed] *in a predetermined* rpm range that yields higher energy efficiency for fuel and pollution reduction[;], *where* the [fixed rpm is defined to generally refer to the] *predetermined* rpm range is set to achieve the optimal brake specific fuel consumption, wherein the engine runs at lower fuel consumption but relatively [paying] higher output power when the system is operating as a series or parallel hybrid power train; the power generated by the first dynamo-electrical unit (101) driven by the engine recharges the main rechargeable device (106);

or the power from the main rechargeable device (106) and that from the first dynamo-electrical unit (101) jointly drive the second dynamo-electrical unit (103) to operate as a motor to drive the second load ([120] 120b) for controlling the engine to run [at a fixed] *in the predetermined* rpm range that yields higher energy efficiency[; the fixed rpm is defined to generally refer to the rpm range to achieve the optimal brake specific fuel consumption wherein the engine runs at lower fuel consumption but relatively paying higher output power when the system is operating as a series or parallel hybrid power train];

when the system operates as a parallel hybrid power train, the power from the main rechargeable device (106) drives the first dynamo-electrical unit (101) in the first drive system (1001) and/or the second dynamo-electrical unit (103) in the second drive system (1002) to operate as a motor to jointly drive the second load ([120] 120b) with the engine; in case of a light load, while driving the second load ([120] 120b), the rotational kinetic energy from the engine also drives the first dynamo-electrical unit (101), and the second dynamo-electrical unit (103) in the second drive system (1002) or

any part of the second dynamo-electrical unit (103) therein to recharge the main rechargeable device (106) or supply power to any other power driven load (130); in case of a heavy load, the power from the main rechargeable device (106) drives the first dynamo-electrical unit (101) in the first drive system (1001) and the second dynamo-electrical unit (103) in the second drive system (1002), or any part of the second dynamo-electrical unit (103) therein, for jointly driving the load with [those] the rotational kinetic energy outputted from the engine;

through the manipulation of the drive control unit (104), the power from the main rechargeable device (106) drives at least one of the first dynamo-electrical unit (101) in the first drive system (1001), and the second dynamo-electrical unit (103) in the second drive system (1002) [or any part of the second dynamo-electrical unit (103) therein operates] to operate as a [generator for driving] motor through controlling the fourth clutch (132) to perform engagement and disengagement to drive at least one of the [second] first load ([120] 120a) in the first drive system (1001) and the second load (120b) in the second drive system (1002);

the first dynamo-electrical unit (101) in the first drive system (1001), and the second dynamo-electrical unit (103) in the second drive system (1002) or any part of the second dynamo-electrical unit (103) therein is driven by the engine to operate as a generator to recharge the main rechargeable device (106) or supply power to the auxiliary load (130);

the first dynamo-electrical unit (101) in the first drive system (1001), and the second dynamo-electrical unit (103) in the second drive system (1002) or any part of the second dynamo-electrical unit (103) therein is inversely driven by the second load ([120] 120b) to operate as a generator for power regeneration to recharge the main rechargeable device (106) or supply power to the auxiliary load (130);

the mechanical damping of the engine provides mechanical braking [function], and the first dynamo-electrical unit (101) in the first drive system (1001), and the second dynamo-electrical unit (103) in the second drive system (1002) or any part of the second dynamo-electrical unit (103) therein operates as a generator to recharge the main rechargeable device (106) or supply power to the auxiliary load (130);

the main rechargeable device (106) drives the first dynamo-electrical unit (101) in the first drive system (1001), and the second dynamo-electrical unit (103) in the second drive system (1002) or any part of the second dynamo-electrical unit (103) therein operates as a motor to start up the engine;

the fourth clutch (132) is controlled to close up for transmitting the rotational function between the active rotational power source (100) and the second drive system (1002) and to interrupt the transmission of rotational kinetic energy when disengaged; wherein:

in the first drive system (1001), a power generation unit (2000) performs mutual transmission with the output shaft of the active rotational power source (100) through the second transmission unit (129); the power generation unit (2000), apart from provided with the second transmission unit (129) for the mutual transmission with the output shaft of the active rotational power source (100), through the first clutch (102) of the power generation unit (2000), is coupled to the first dynamo-electrical unit (101) directly or through the first transmission unit (109); and the output shaft of the active rotational

power source (100) is coupled to the first clutch (112) and [the first] a third transmission unit ([109] 109b) to drive the first load ([120] 120a) to constitute jointly with the power generation unit (2000) the first drive system (1001);

in the second drive system (1002), the second dynamo-electrical unit (103) serving as the power source for the second drive system (1002) drives the second load ([120] 120b);

[furthermore,] as [required] controlled by the drive control unit, the active rotational power source (100) is coupled [to] through the first clutch (102) [coupled] to the rotary part of the first dynamo-electrical unit (101) [driven by] of the first drive system (1001), the active rotational power source is coupled to the input terminal of the fourth clutch (132); and the output terminal of the fourth clutch (132) is coupled to the rotary part of the second dynamo-electrical unit (103) serving as the power source for the second drive system (1002), [or] and the input terminal of the second load ([120] 120b) driven by the second drive system (1002) for the control of the transmission status of the rotational kinetic energy between the first drive system (1001) and the second drive system (1002),

whereby, through the aforementioned system operation, the outputted rotational kinetic energy serves to drive any type of load driven by rotational kinetic energy.

2. A split serial-parallel hybrid dual-power drive system as claimed in claim 1, wherein,

in the second drive system (1002), two or more than two second dynamo-electrical units ([103] 103b and 103c) serving as the power source for the second drive system (1002) respectively drive the [first loads (120)] second load (120b1) and a third load (120b2).

3. A split serial-parallel hybrid dual-power drive system as claimed in claim 1, including the transmission status of the rotational kinetic energy between the first drive system (1001) and the second drive system (1002) is controlled by closing up or disengaging the fourth clutch (132).

4. A split serial-parallel hybrid dual-power drive system as claimed in claim 1, [furthermore,] wherein the active rotational power source (100) is coupled to the second clutch (112) [coupled to] in the first drive system (1001), and the active rotational power source is coupled to the fourth clutch (132); [meanwhile] the output terminal of the fourth clutch (132) [is] being coupled to the second drive system (1002) to respectively drive two rotary parts of [both] two second dynamo-electrical units ([103] 103b and 103c) serving as the power source for the second drive system (1002) for the control of the driving status of the active rotational power source (100) toward the first drive system (1001) and the second drive system (1002).

5. A split serial-parallel hybrid dual-power drive system employing rotational kinetic energy;

the split serial-parallel hybrid dual-power drive system comprising two or more drive systems incorporated in a common frame that is driven by the kinetic energy of at least one drive system;

the dual-power drive system including a first drive system and a second drive system;

the first drive system including an active power source, a first dynamo-electrical unit functioning as a generator, and a second dynamo-electrical unit functioning as a motor, driven by a drive control unit (104) to control the active rotational power source (100) to output transmission status of the rotational kinetic energy;

75

the second drive system including a third dynamo-electrical unit functioning as a motor to serve as a rotational power source for the second drive system;

by means of the control and operation of a control system or manually, the active rotational power source and the first dynamo-electrical unit of the separation serial-parallel hybrid drive system are coupled, and the first dynamo-electrical unit and the second dynamo-electrical unit are separated; and

either the active rotational kinetic energy source drives the first dynamo-electrical unit to output electric power to further drive the second dynamo-electrical unit to operate as a motor to function as a series hybrid power train; or the active rotational power source is coupled to at least one of the first and the second dynamo-electrical units, and a rechargeable device to function as a parallel hybrid power train;

the split serial-parallel hybrid dual-power drive system comprised of the active rotational power source, the first and second dynamo-electrical units, second clutch, drive control unit, central control unit, rechargeable device, auxiliary rechargeable device, and load as follows:

the active rotational power source (100), comprising at least one of an internal combustion engine and an external combustion engine is a rotational kinetic energy power source; a rotary part of the active rotational source directly coupled to the first dynamo-electrical unit (101);

the first dynamo-electrical unit (101) is configured to be switched to operate as a generator or a motor; when the second dynamo-electrical unit (103a) is connected to the first drive system (1001), the rotary part of the first dynamo-electrical unit (101) is coupled to the second dynamo-electrical unit (103) through the second clutch (112);

the second dynamo-electrical unit (103) is configured to be switched to operate as a generator or a motor to become the rotational power source for the second drive system (1002); the output terminal of the rotary part of the second dynamo-electrical unit (103) directly outputs the rotational kinetic energy to drive the second load or outputs the rotational kinetic energy to drive the second load;

the second clutch (112) transmits or interrupts the rotational kinetic energy and is coupled between the second dynamo-electrical unit (103) and the first dynamo-electrical unit (101);

a fourth clutch (132) transmits or interrupts the rotational kinetic energy and is coupled between the rotary part of the active rotational power source (100) and the rotary part of the second dynamo-electrical unit (103) of the second drive system (1002) to control whether the rotational kinetic energy between the first and the second drive systems (1001, 1002) is to be transmitted or interrupted;

the drive control unit (104) includes a circuit configured to provide at least one of the following functions:

for the system to operate as a series hybrid power system; when the first dynamo-electrical unit (101) in the first drive system (1001) operates as a generator, the drive control unit (104) controls the power outputted to drive the second dynamo-electrical unit (103) of the second drive system (1002), and/or recharge the main rechargeable device (106);

76

the drive control unit controls the power from the main rechargeable device (106) to drive the first and the second dynamo-electrical units (101, 103) each operating as a motor;

when subject to the drive control unit (104), the first dynamo-electrical unit (101) in the first drive system (1001) and the second dynamo-electrical unit (103) in the second drive system (1002), or any part of those dynamo-electrical units therein is inversely driven to operate as a generator to control the recharging power outputted to the main rechargeable device (106), or power is supplied to other loads, for at least one dynamo-electrical unit to produce a braking function by regenerated power;

the central control unit (105) is subject to a control interface (107) to control the operation of the split serial-parallel hybrid dual-power drive system, for optimal fuel consumption and pollution control, the optimal brake specific fuel consumption applicable to the system either operating as series or parallel hybrid power train by operating the engine in a range of rpm that consumes less fuel yet outputs power more efficiently; the central control unit (105) operates the drive control unit (104) to control the operation of the first dynamo-electrical unit (101) in the first drive system (1001), the second dynamo-electrical unit (103) in the second drive system (1002), and the main rechargeable device (106), and operates the drive control unit to control feedback monitoring and interaction between the units in the system;

the control interface (107) is configured to receive inputs manually or by control signals to control the operation of the serial-parallel dual-power system;

the auxiliary rechargeable device (110) is controlled by a startup switch (111) to drive a startup motor (121) adapted to drive an engine serving as the active rotational power source (100) thus to supply power to an auxiliary load (130);

the auxiliary load (130) is selectively driven by the generated power from the first dynamo-electrical unit (101) or the second dynamo-electrical unit (103) operating as a generator, or by the power from the main rechargeable device (106) or the auxiliary rechargeable device (110) to output the rotational kinetic energy with the engine as the active rotational power source, the split serial-parallel hybrid dual-power drive system providing at least one of the following functions:

the rotational kinetic energy from the engine power drives a first load (120a) of the first drive system (1001) and/or a second load (120b) of the second drive system (1002);

when the system is operating as a series hybrid power train, the engine is controlled to run from lower rpm up to higher rpm, or at a preset rpm to drive the first dynamo-electrical unit (101) in the first drive system (1001) to operate as a generator;

in case of a light load, the power generated by the first dynamo-electrical unit (101) in the first drive system (1001) drives the second dynamo-electrical unit (103) in the second drive system (1002) while recharging the main rechargeable device (106) at the same time; and

in case of a heavy load,

either the power generated by the first dynamo-electrical unit (101) in the first drive system (1001) and that from the main rechargeable device (106) jointly drive the second dynamo-electrical unit (103) of the second drive system (1002) for outputting the rotational kinetic energy to drive the second load (120b) to control the engine to run in a predetermined rpm range that yields



high energy efficiency for fuel and pollution reduction; the predetermined rpm range being set to achieve the optimal brake specific fuel consumption wherein the engine runs at lower fuel consumption but relatively higher output power when the system is operating as a series or parallel hybrid power train; the power generated by the first dynamo-electrical unit (101) driven by the engine recharges the main rechargeable device (106);

or the power from the main rechargeable device (106) and that from the first dynamo-electrical unit (101) jointly drive the second dynamo-electrical unit (103) to operate as a motor to drive the second load (120b) for controlling the engine to run in the predetermined rpm range that yields high energy efficiency;

when the system operates as a parallel hybrid power train, the power from the main rechargeable device (106) drives the first dynamo-electrical unit (101) in the first drive system (1001) and/or the second dynamo-electrical unit (103) in the second drive system (1002) to operate as a motor to jointly drive the second load (120b) with the engine; in case of a light load, while driving the second load (120b), the rotational kinetic energy from the engine also drives the first dynamo-electrical unit (101), and the second dynamo-electrical unit (103) in the second drive system (1002) or any part of the second dynamo-electrical unit (103) therein to recharge the main rechargeable device (106) or supply power to any other power driven load (130); in case of a heavy load, the power from the main rechargeable device (106) drives the first dynamo-electrical unit (101) in the first drive system (1001) and the second dynamo-electrical unit (103) in the second drive system (1002) or any part of the second dynamo-electrical unit (103) therein for jointly driving the load with the rotational kinetic energy outputted from the engine;

through the manipulation of the drive control unit (104), the power from the main rechargeable device (106) drives at least one of the first dynamo-electrical unit (101) in the first drive system (1001) and the second dynamo-electrical unit (103) in the second drive system (1002) to operate as a motor for respectively driving the second load (120b);

the first dynamo-electrical unit (101) in the first drive system (1001), and the second dynamo-electrical unit (103) in the second drive system (1002) or any part of the second dynamo-electrical unit (103) therein is driven by the engine to operate as a generator to recharge the main rechargeable device (106) or supply power to the auxiliary load (130);

the first dynamo-electrical unit (101) in the first drive system (1001), and the second dynamo-electrical unit (103) in the second drive system (1002) or any part of the second dynamo-electrical unit (103) therein is inversely driven by the second load (120b) to operate as a generator for power regeneration to recharge the main rechargeable device (106) or supply power to the auxiliary load (130);

the mechanical damping of the engine provides mechanical braking, and the first dynamo-electrical unit (101) in the first drive system (1001), and the second dynamo-electrical unit (103a) in the second drive system (1002) or any part of the second dynamo-electrical unit (103) therein operates as a generator to recharge the main rechargeable device (106) or supply power to the auxiliary load (130);

the main rechargeable device (106) drives the first dynamo-electrical unit (101) in the first drive system (1001), and the second dynamo-electrical unit (103) in the second drive system (1002) or any part of the second dynamo-electrical unit (103) therein operates as a motor to start UP the engine; wherein:

in the first drive system (1001), a power generation unit (2000) performs mutual transmission with the output shaft of the active rotational power source (100) of the power generation unit (2000), is coupled to the first dynamo-electrical unit (101) directly; and the output shaft of the active rotational power source (100) is coupled to the second clutch (112) to drive the first load (120a) to constitute jointly with the power generation unit (2000) the first drive system (1001);

in the second drive system (1002), the second dynamo-electrical unit (103) serving as the power source for the second drive system (1002) drives the second load (120b);

whereby, through the aforementioned system operation, the outputted rotational kinetic energy serves to drive any type of load driven by rotational kinetic energy.

6. A split serial-parallel hybrid dual-power drive system employing rotational kinetic energy;

the split serial-parallel hybrid dual-power drive system comprising two or more drive systems incorporated in a common frame that is driven by the kinetic energy of at least one drive system;

the dual-power drive system including a first drive system and a second drive system;

the first drive system including an active power source (100), the active power source (100) configured to drive a second transmission unit (129), the second transmission unit (129) configured to drive a first dynamo-electrical unit (101) functioning as a generator and to drive a second clutch (112) and a transmission unit (109) for driving the load of the first drive system (1001), and manually or by control and operation of the second clutch (112) controlled by a drive control unit (104) to control the active rotational power source (100) to output transmission status of the rotational kinetic energy to the load (120a, 120a1, and 120a2) of the first drive system (1001);

the second drive system including a second dynamo-electrical unit (103, 103b, and 103c) functioning as a motor to serve as a rotational power source for the second drive system;

by control and operation of a control system configured by a drive control unit (104), a central control unit (105), and a control interface (107) or manually, the split serial-parallel hybrid dual-power drive system is capable of performing following one or more functional operations, including:

when the second clutch (112) is disengaged, the active rotational kinetic energy source drives the first dynamo-electrical unit (101) of the first drive system (1001) through the second transmission unit (129) to operate as a generator for outputting electric power, and through the control and operation of the drive control unit (104) to drive the second dynamo-electrical unit of the second drive system (1002) to operate as a motor for driving the load (120b, 120b1, and 120b2) of the second drive system (1002) to function as a series hybrid power train;

when the second clutch (112) is engaged, through the control and operation of the second transmission unit (129), the second clutch (112), and the transmission unit (109),

*the active rotational power source is configured to drive a load of the first drive system (1001).*

7. *A split serial-parallel hybrid dual-power drive system as claimed in claim 6, wherein, a first clutch (102) and/or a first transmission unit (109a) is further installed in the first drive system (1001) between the second transmission unit (129) driven by the active power source(100) and the first dynamo-electrical unit (101) to selectively transmit or interrupt the rotational kinetic energy of the active power source(100) for driving the first dynamo-electrical unit (101).*

8. *A split serial-parallel hybrid dual-power drive system as claimed in claim 6, wherein, a transmission unit (109e, 109f, 109f1, and 109f2) and/or a third clutch (122) is further installed in the second drive system (1002) between the second dynamo-electrical unit (103, 103a, and 103b) and load (120b, 120b1, and 120b2).*

9. *A split serial-parallel hybrid dual-power drive system as claimed in claim 6, further comprising a main rechargeable device (106).*

10. *A split serial-parallel hybrid dual-power drive system as claimed in claim 6, further comprising a fourth clutch (132) installed between the second transmission unit (129) of the first drive system (1001) and the input end of the transmission unit (109e) of the second drive system (1002) to control the rotational kinetic energy of the active power source(100) for driving the load (120a, 120a1, and 120a2) of the first drive system (1001) and/or the load (120b, 120b1, and 120b2) of the second drive system (1002).*

11. *A split serial-parallel hybrid dual-power drive system as claimed in claim 6, comprising the active rotational power source, first clutch, the first and second dynamo-electrical units, second clutch, third clutch, fourth clutch, transmission unit, drive control unit, central control unit, rechargeable device, auxiliary rechargeable device, and load as follows:*

*the active rotational power source (100): comprising at least one of an internal combustion engine and an external combustion engine, is a rotational kinetic energy power source; a rotary part of the active rotational source selectively either directly coupled to the first dynamo-electrical unit (101) or indirectly coupled to the rotary part of the first dynamo-electrical unit (101) through a second transmission unit (129), and/or the first clutch (102), and/or a first transmission unit (109); the first dynamo-electrical unit (101) and the second dynamo-electrical unit (103, 103b, 103c) are configured to be switched to operate as a generator or a motor, and each constituted by AC or DC, brush or brushless, synchronous or asynchronous rotational electrical machines;*

*the first clutch (102), second clutch (112), third clutch (122) and fourth clutch (132): are configured by the clutch devices with the functions to transmit or interrupt the rotational kinetic energy by means of the operation and control of the drive control unit (104) or manually, relates to a transmission operating by manual, mechanical force, eccentric force, air pressure, or hydraulic flow force, or electro-magnetism controlled clutch, or single way clutch, or coupler with torque controllable, or any other transmission device that transmits or interrupt the mechanical rotational kinetic energy, or the function of the clutch may be replaced with the idling function or the torque coupling function with torque controllable provided by the transmission device (109);*

*the transmission unit (129, 129a) is comprise of an automatic, semi-automatic or manual multiple-speed or continuously variable transmission device or one at a fixed*

*speed ratio, or a differential gear set, or a rotational gear set, a fluid torque coupler, or a belt continuously variable transmission (CVT) or any other transmission of the prior art that is provided with idling and inverse gear functions;*

*the transmission unit (109, 109b, 109e, 109f, 109f1, 109f2) comprises an automatic, semi-automatic or manual multiple-speed or continuously variable transmission device or one at a fixed speed ratio, or a differential gear set, or a rotational gear set, a fluid torque coupler, or a belt continuously variable transmission (CVT) or any other transmission of the prior art that is provided with idling and inverse gear functions;*

*the central control unit (105) is subject to a control interface (107) to control the operation of the split serial-parallel hybrid dual-power drive system, particularly to the optimal fuel consumption of pollution control, the optimal brake specific fuel consumption applicable to the system either operating as series or parallel hybrid power train by operating the engine in a range of rpm that consumes less fuel yet outputs higher power more efficiently; the central control unit (105) by controlling the drive control unit (104) to control the operation of relative functions among the first dynamo-electrical unit (101) in the first drive system (1001), the first dynamo-electrical unit (101) in the first drive system (1001) and/or the second dynamo-electrical unit (103, 103b, 103c) in the second drive system (1002), and the main rechargeable device (106), and controls feedback monitoring and interaction between the units in the system; the control interface (107) is configured to receive inputs manually or by control signals to control the operation of the separation serial-parallel dual-power system; the auxiliary rechargeable device (110) is controlled by a startup switch (111) to drive a startup motor (121) adapted to drive an engine serving as the active rotational power source (100) thus to supply power to an auxiliary load (130);*

*the auxiliary load (130) is selectively driven by the generated power from the first dynamo-electrical unit (101) or the first dynamo-electrical unit (101) in the first drive system (1001) and/or the second dynamo-electrical unit (103, 103b, 103c) operating as a generator, or by the power from the main rechargeable device (106) or the auxiliary rechargeable device (110);*

*the drive control unit (104) includes a circuit configured to provide at least one of the following functions: for the system to operate as a series hybrid power system; when the first dynamo-electrical unit (101) in the first drive system (1001) operates as a generator, the drive control unit (104) controls the power outputted to drive the second dynamo-electrical unit (103, 103b, 103c) of the second drive system (1002), and/or recharge the main rechargeable device (106);*

*controls the power from the main rechargeable device (106) to drive all or part of the dynamo-electrical units including the first dynamo-electrical unit (101), in the first drive system (1001) and the second dynamo-electrical unit (103, 103b, 103c) in the second drive system (1002) to operate as a motor;*

*when subject to the drive control unit (104), all or part of the dynamo-electrical units including the first dynamo-electrical unit (101) in the first drive system (1001), and the second dynamo-electrical unit (103, 103b, 103c) in the second drive system (1002) are inversely driven to operate as a generator to control the recharging power outputted to the main rechargeable device (106) or*

81

power supplied to other load for the dynamo-electrical unit to operate for braking function by regenerated power.

12. A split serial-parallel hybrid dual-power drive system as claimed in claim 6, wherein

with the engine as the active rotational power source, the split serial-parallel hybrid dual-power drive system provides at least one of the following functions:

through the driving by the rotational kinetic energy from the engine power and the operation and control clutches between the first clutch (102), second clutch (112), third clutch (122) and the load to drive a first load (120a, 120a1, 120a2) of the first drive system (1001) and/or a second load (120b, 120b1, 120b2) of the second drive system (1002);

through the driving by the rotational kinetic energy from the engine power and the operation and control clutches between the first clutch (102), second clutch (112), third clutch (122) and the transmission unit (129b) of the second drive system (1002) and the load to perform engagement or disengagement, so as to drive at least one of the first load (120a, 120a1, 120a2) in the first drive system (1001) and the second load (120b, 120b1, 120b2) in the second drive system (1002);

when the system is operating as a series hybrid power train, the engine is controlled to run from lower rpm up to higher rpm, or at a preset rpm to drive the first dynamo-electrical unit (101) in the first drive system (1001) to operate as a generator; in case of a light load, the power generated by the first dynamo-electrical unit (101) in the first drive system (1001) drives the second dynamo-electrical unit (103, 103b, 103c) in the second drive system (1002), or recharging the main rechargeable device (106) at the same time; and in case of a heavy load, while driving the load by the active rotational power source (100) constituted by the engine, the power generated by the first dynamo-electrical unit (101) in the first drive system (1001) and that from the main rechargeable device (106) jointly drive the second dynamo-electrical unit (103, 103b, 103c) of the second drive system (1002) at the same time for outputting the rotational kinetic energy to drive the second load (120b, 120b1, 120b2); in case of a light or heavy load aforementioned, it is through the control of the central control unit (105) and the drive control unit (104) to manipulate and control the engine to run in a predetermined rpm range that yields higher energy efficiency for fuel and pollution reduction; the predetermined rpm range achieving the optimal brake specific fuel consumption wherein the engine runs at lower fuel consumption but relatively higher output power when the system is operating as a series or parallel hybrid power train;

when the system operates as a parallel hybrid power train, the power from the main rechargeable device (106) drives all or part of the dynamo-electrical units including the first dynamo-electrical unit (101) in the first drive system (1001) and the second dynamo-electrical unit (103, 103b, 103c) in the second drive system (1002) to operate as a motor to jointly drive at least one of the loads (120a, 120a1, 120a2) in the first drive system (1001) and/or the loads (120b, 120b1, 120b2) in the second drive system (1002) with the engine; in case of a light load, while driving the at least one of the loads (120a, 120a1, 120a2) in the first drive system (1001) and/or the loads (120b, 120b1, 120b2) in the second drive system (1002), the rotational kinetic energy from the engine also drives all or part of the dynamo-electri-

82

cal units including the first dynamo-electrical unit (101), and the second dynamo-electrical unit (103, 103b, 103c) in the second drive system (1002) to operate as a generator to recharge the main rechargeable device (106) or supply power to any other power driven load (130); in case of a heavy load, the power from the main rechargeable device (106) drives all or part of the dynamo-electrical units including the first dynamo-electrical unit (101) in the first drive system (1001), and the second dynamo-electrical unit (103, 103b, 103c) in the second drive system (1002) to operate as a motor for jointly driving the load with those rotational kinetic energy outputted from the engine;

the power from the main rechargeable device (106) drives all or part of the dynamo-electrical units including the first dynamo-electrical unit (101), and the second dynamo-electrical unit (103, 103b, 103c) in the second drive system (1002) to operate as a motor, through controlling the fourth clutch (132);

all or part of the dynamo-electrical units including the first dynamo-electrical unit (101) in the first drive system (1001), and the second dynamo-electrical unit (103, 103b, 103c) in the second drive system (1002) is driven by the engine to operate as a generator to recharge the main rechargeable device (106) or supply power to the auxiliary load (130);

all or part of the dynamo-electrical units including the first dynamo-electrical unit (101) in the first drive system (1001), and the second dynamo-electrical unit (103, 103b, 103c) in the second drive system (1002) is inversely driven by at least one of the loads (120a, 120a1, 120a2) in the first drive system (1001) and/or the loads (120b, 120b1, 120b2) in the second drive system (1002) to operate as a generator for power regeneration to recharge the main rechargeable device (106) or supply power to the auxiliary load (130);

the mechanical damping of the engine provides braking function, and all or part of the dynamo-electrical units including the first dynamo-electrical unit (101) in the first drive system (1001), and the second dynamo-electrical unit (103, 103b, 103c) in the second drive system (1002) operates as a generator to recharge the main rechargeable device (106) or supply power to the auxiliary load (130);

the main rechargeable device (106) drives the first dynamo-electrical unit (101) in the first drive system (1001) to operate as a motor to start up the engine, and the second clutch 112 is separated;

in the first drive system (1001), the rotary part outputs the rotational kinetic energy from the active rotational power source (100) to drive the first dynamo-electrical unit (101) and the rotary part of the first dynamo-electrical unit (101) is coupled to the input terminal of the second clutch (112), and/or a transmission unit (109) to drive the first load (120a, 120a1, 120a2);

in the second drive system (1002), the second dynamo-electrical unit (103, 103b, 103c) serving as the power source for the second drive system (1002) drives the load (120b, 120b1, 120b2);

as controlled by the drive control unit, the active rotational power source (100) connected with the transmission unit (129) is coupled to the input terminal of the fourth clutch (132); and the output terminal of the fourth clutch (132) is coupled to the rotary part of the second dynamo-electrical unit (103, 103b, 103c) serving as the power source for the second drive system (1002), or the input terminal of the second load (120b, 120b1, 120b2) driven

by the second drive system (1002) for the control of the transmission status of the rotational kinetic energy between the first drive system (1001) and the second drive system (1002), i.e. to transmit the rotational function between the active rotational power source (100) 5 and the second drive system (1002) when engaged and to interrupt the transmission of rotational kinetic energy when disengaged;

whereby, through the aforementioned system operation, the outputted rotational kinetic energy can serve to drive 10 any type of load driven by rotational kinetic energy.

13. A split serial-parallel hybrid dual-power drive system as claimed in claim 6, serves to drive two loads through a third clutch (122) and then through a transmission unit (109).

14. A split serial-parallel hybrid dual-power drive system 15 as claimed in claim 6, wherein two or more second dynamo-electrical units (103) serve to individually drive the respectively adapted load through the respectively adapted transmission unit and/or third clutch 122.

\* \* \* \* \*

20