



US00RE46000E

(19) **United States**
(12) **Reissued Patent**
Kim et al.

(10) **Patent Number:** **US RE46,000 E**
(45) **Date of Reissued Patent:** **May 10, 2016**

(54) **CHANNEL EQUALIZER AND METHOD OF PROCESSING BROADCAST SIGNAL IN RECEIVING SYSTEM**

H04L 25/022; H04L 25/03159; H04N 7/163;
H04N 21/235
See application file for complete search history.

(71) Applicant: **LG ELECTRONICS INC.**, Seoul (KR)

(56) **References Cited**

(72) Inventors: **Byoung Gill Kim**, Seoul (KR); **In Hwan Choi**, Gwacheon-si (KR); **Kook Yeon Kwak**, Anyang-si (KR)

U.S. PATENT DOCUMENTS

(73) Assignee: **LG ELECTRONICS INC.**, Seoul (KR)

5,588,027 A 12/1996 Lim
5,937,014 A 8/1999 Pelin et al.

(21) Appl. No.: **14/262,323**

(Continued)

(22) Filed: **Apr. 25, 2014**

FOREIGN PATENT DOCUMENTS

Related U.S. Patent Documents

Reissue of:

KR 10-2005-0077255 8/2005
KR 10-2005-0107286 11/2005

(64) Patent No.: **8,175,196**
Issued: **May 8, 2012**
Appl. No.: **13/051,851**
Filed: **Mar. 18, 2011**

(Continued)

OTHER PUBLICATIONS

U.S. Applications:

U.S. Appl. No. 14/306,064, Office Action dated Jun. 2, 2015, 18 pages.

(63) Continuation of application No. 12/851,376, filed on Aug. 5, 2010, now Pat. No. 7,933,351, which is a continuation of application No. 11/681,554, filed on Mar. 2, 2007, now Pat. No. 7,796,697.

(Continued)

(60) Provisional application No. 60/883,500, filed on Jan. 4, 2007.

Primary Examiner — Eric B Kiss

(74) *Attorney, Agent, or Firm* — Lee, Hong, Degerman, Kang & Waimey; Jonathan Kang; Harry Lee

(30) **Foreign Application Priority Data**

Mar. 2, 2006 (KR) 10-2006-0020140
Sep. 15, 2006 (KR) 10-2006-0089736

(57) **ABSTRACT**

(51) **Int. Cl.**
H04L 27/06 (2006.01)
H04L 25/02 (2006.01)
(Continued)

A channel equalizer includes an overlap unit, an estimator, a calculator, a compensator, and a save unit. The overlap unit overlaps a group of data packets in a broadcast signal. The group data packets include a head, a body, and a tail, and a known data sequence is periodically included in the body. The estimator estimates a CIR of each data region the body using the known data sequence, and it further estimates CIRs of data regions in the head or tail using the CIRs obtained for the data regions in the body. The calculator calculates equalization coefficients based on the CIRs estimated by the estimator, and the compensator compensates channel distortion of the overlapped data using the equalization coefficients. The save unit saves the compensated data.

(52) **U.S. Cl.**
CPC **H04L 25/022** (2013.01); **H04L 1/007** (2013.01); **H04L 1/0047** (2013.01);
(Continued)

(58) **Field of Classification Search**
CPC ... H04L 1/0047; H04L 1/0057; H04L 1/0059;
H04L 1/0065; H04L 1/007; H04L 1/0071;

8 Claims, 11 Drawing Sheets

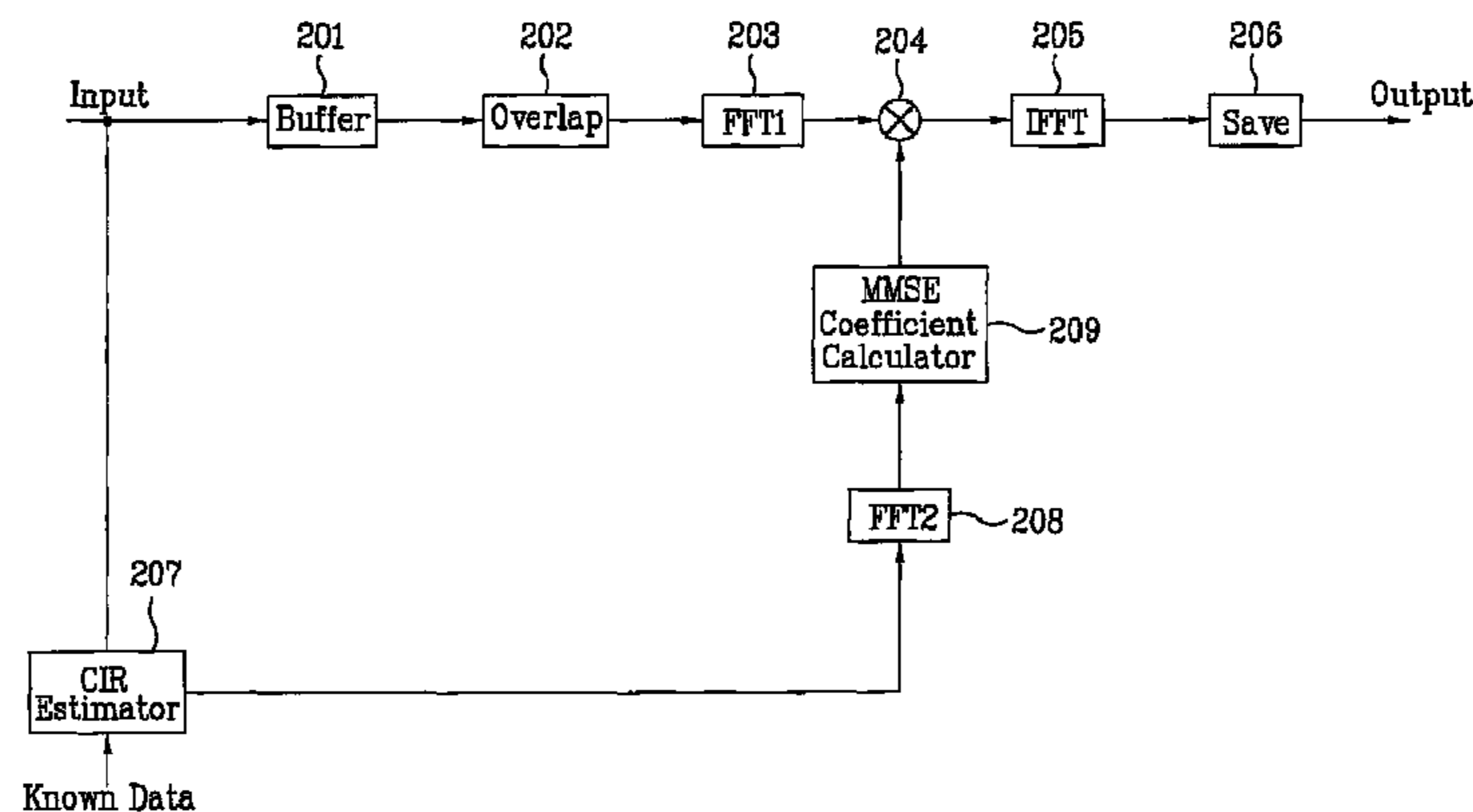

US RE46,000 E

(51)	Int. Cl.		6,289,000 B1	9/2001	Yonge	
	<i>H04N 21/4623</i>	(2011.01)	6,397,368 B1	5/2002	Yonge et al.	
	<i>H04L 1/00</i>	(2006.01)	6,411,253 B1	6/2002	Cox et al.	
	<i>H04L 25/03</i>	(2006.01)	6,903,665 B2	6/2005	Akhter et al.	
	<i>H04N 7/16</i>	(2011.01)	7,940,855 B2 *	5/2011	Kim et al. 375/295
	<i>H04N 21/235</i>	(2011.01)	2002/0145971 A1	10/2002	Cho et al.	
	<i>H04N 21/2383</i>	(2011.01)	2002/0154709 A1	10/2002	Choi et al.	
	<i>H04N 21/434</i>	(2011.01)	2003/0093754 A1	5/2003	Gibson et al.	
	<i>H04N 21/435</i>	(2011.01)	2003/0099281 A1	5/2003	Gibson et al.	
	<i>H04N 21/438</i>	(2011.01)	2003/0103575 A1 *	6/2003	Birru et al. 375/265
(52)	U.S. Cl.		2004/0125235 A1	7/2004	Kim et al.	
	CPC	<i>H04L 1/0057</i> (2013.01); <i>H04L 1/0059</i>	2004/0139378 A1	7/2004	Akhter et al.	
		(2013.01); <i>H04L 1/0065</i> (2013.01); <i>H04L</i>	2007/0217551 A1	9/2007	Kang et al.	
		<i>1/0071</i> (2013.01); <i>H04L 25/03159</i> (2013.01);	2007/0230580 A1	10/2007	Kim et al.	
		<i>H04N 7/163</i> (2013.01); <i>H04N 21/235</i>	2011/0058624 A1	3/2011	Corbel et al.	
		(2013.01); <i>H04N 21/2383</i> (2013.01); <i>H04N</i>	2011/0167467 A1 *	7/2011	Song et al. 725/118
		<i>21/435</i> (2013.01); <i>H04N 21/4345</i> (2013.01);				
		<i>H04N 21/4382</i> (2013.01); <i>H04N 21/4623</i>				
		(2013.01); <i>H04L 1/0054</i> (2013.01); <i>H04L</i>				
		<i>2001/0093</i> (2013.01); <i>H04L 2025/03522</i>				
		(2013.01)				

FOREIGN PATENT DOCUMENTS

KR	10-2005-0109052	11/2005
KR	10-2005-0111535	11/2005
WO	2005/006759	1/2005
WO	WO 20051006759	1/2005
WO	2005/115001	12/2005
WO	WO 20051115001	12/2005

OTHER PUBLICATIONS

Korean Intellectual Property Office Application Serial No. 10-2006-0020140, Notice of Allowance dated Nov. 20, 2012, 3 pages.

* cited by examiner

(56)	References Cited	
		U.S. PATENT DOCUMENTS
	6,009,322 A	12/1999 Dumont
	6,240,129 B1	5/2001 Reusens et al.

FIG. 1

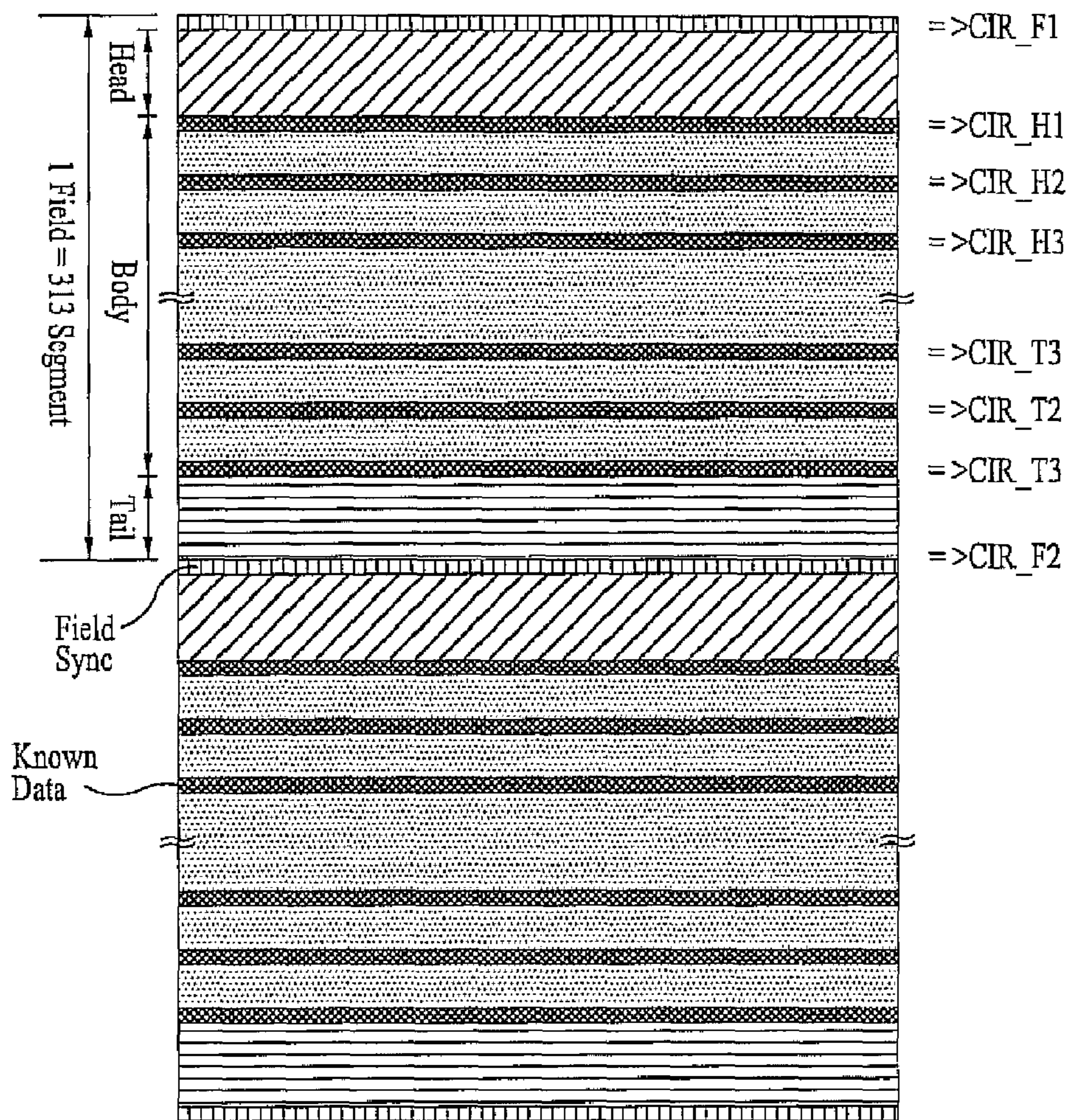

FIG. 2

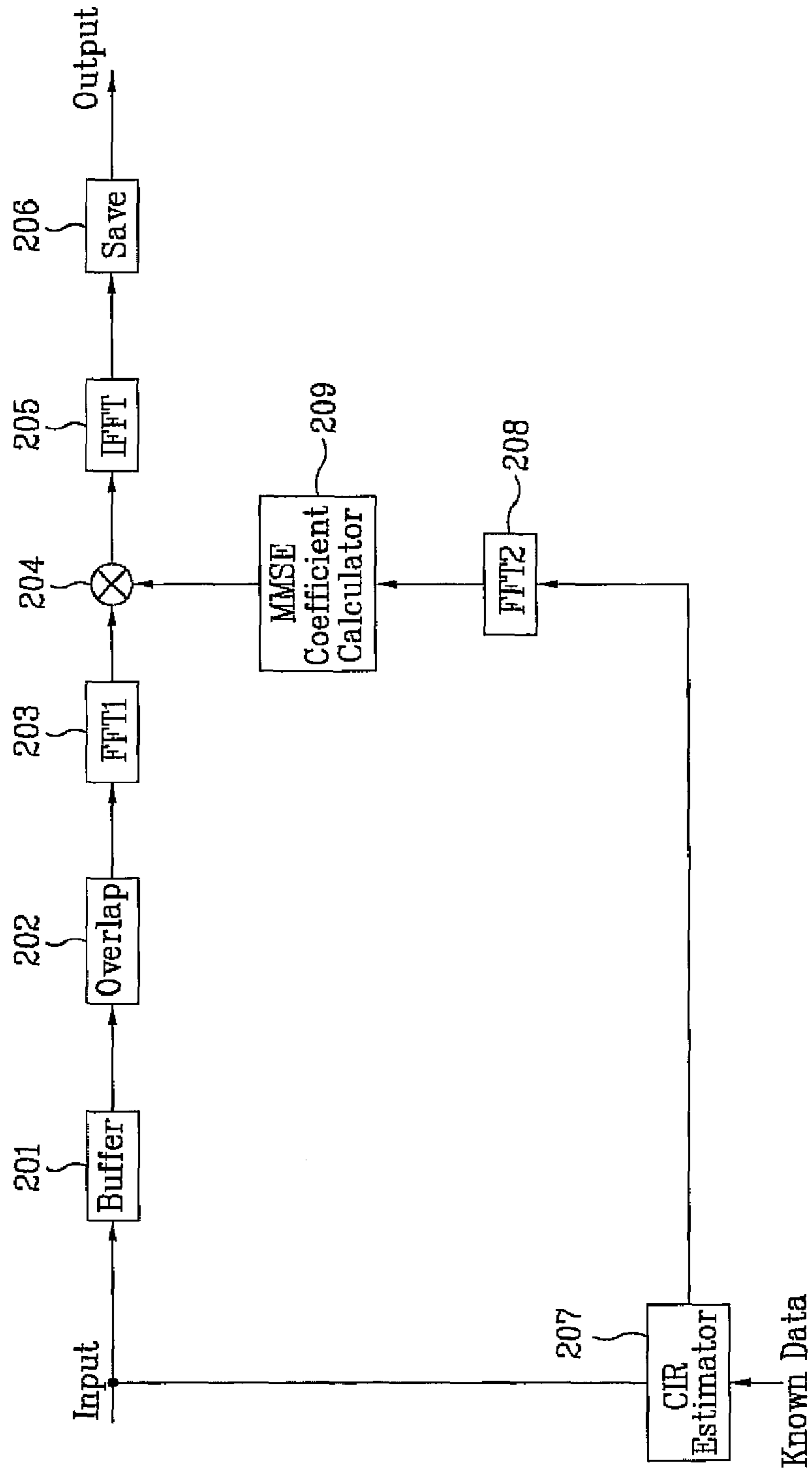

FIG. 3

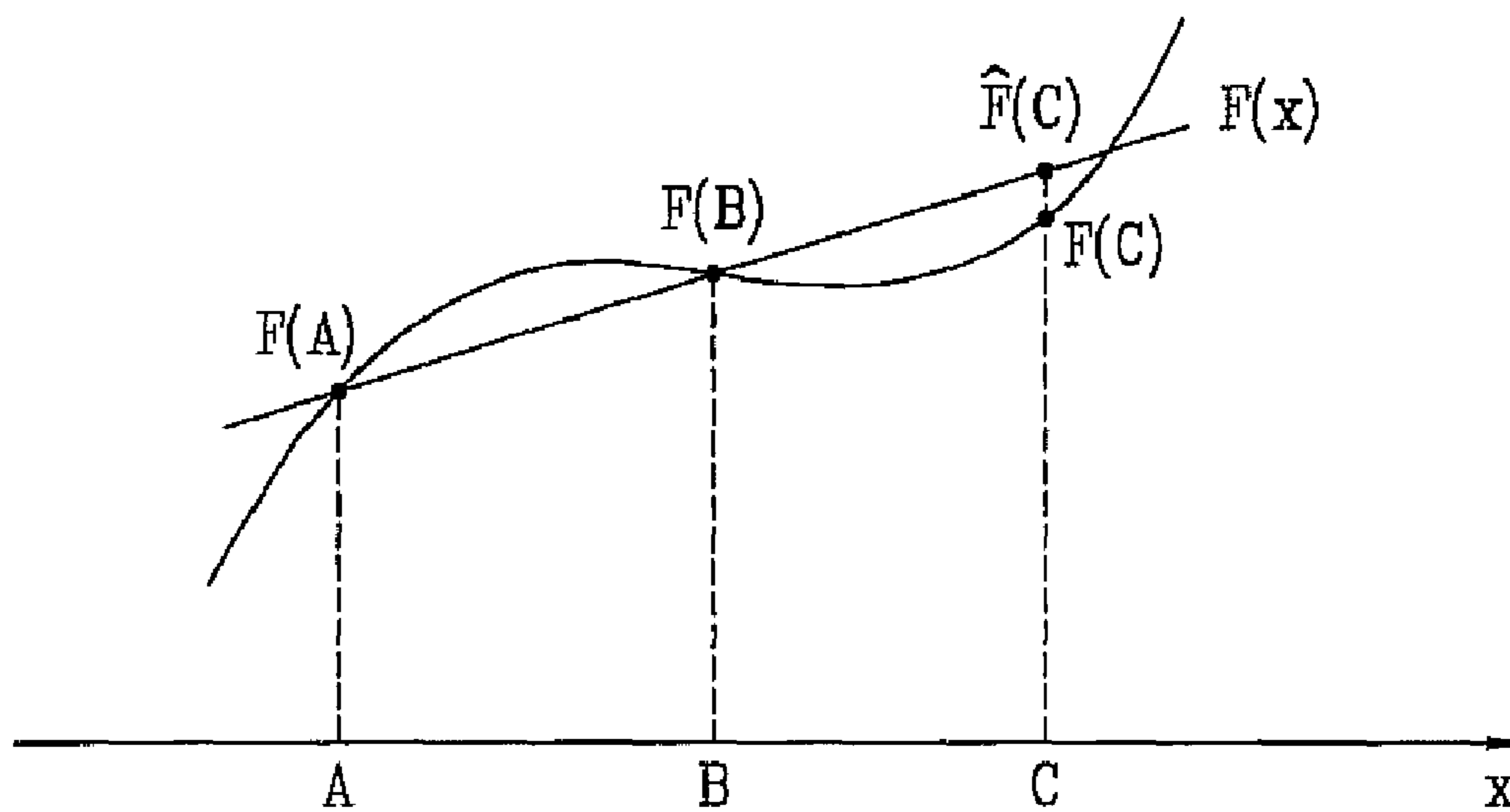

FIG. 4

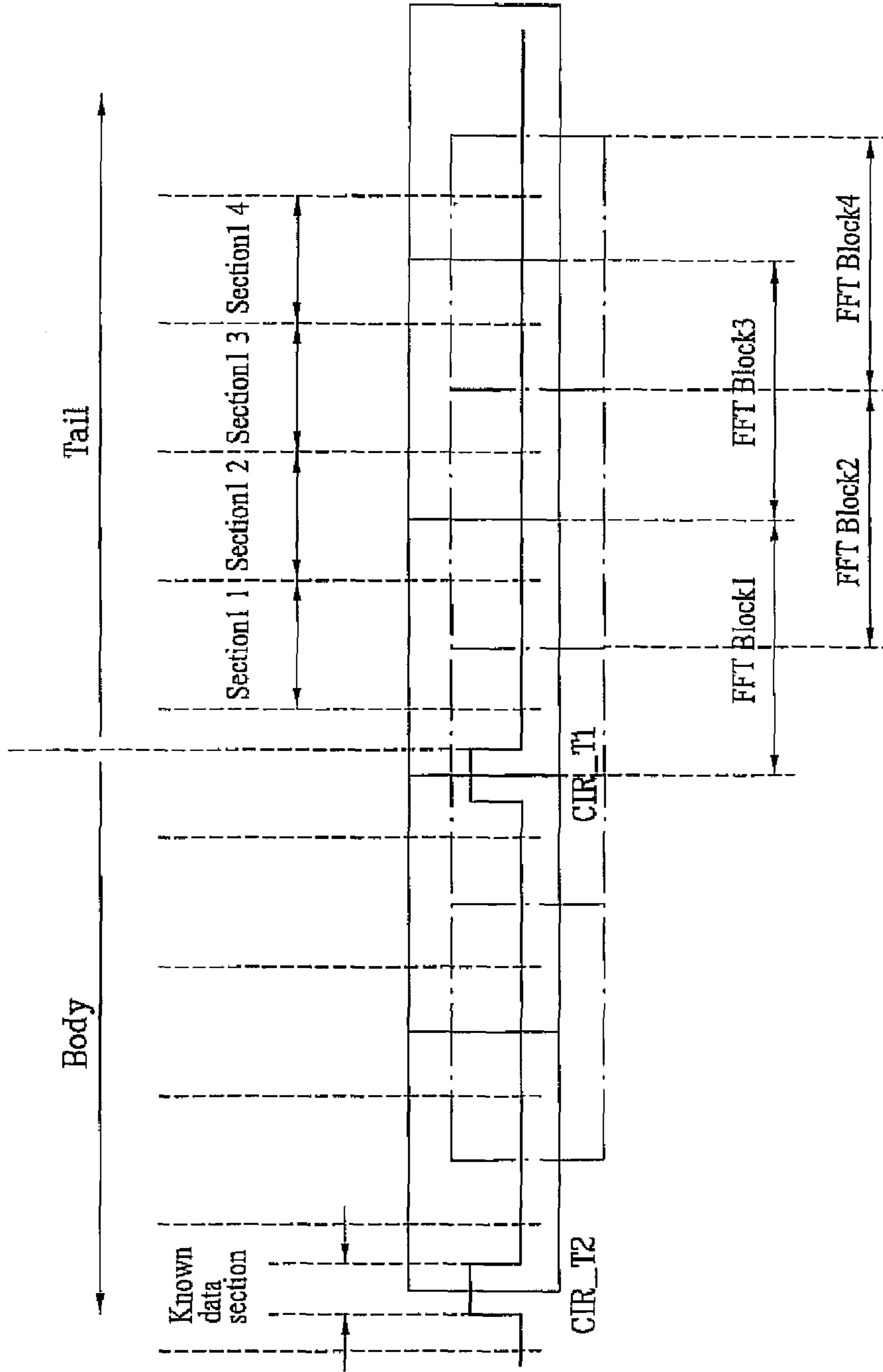

FIG. 5

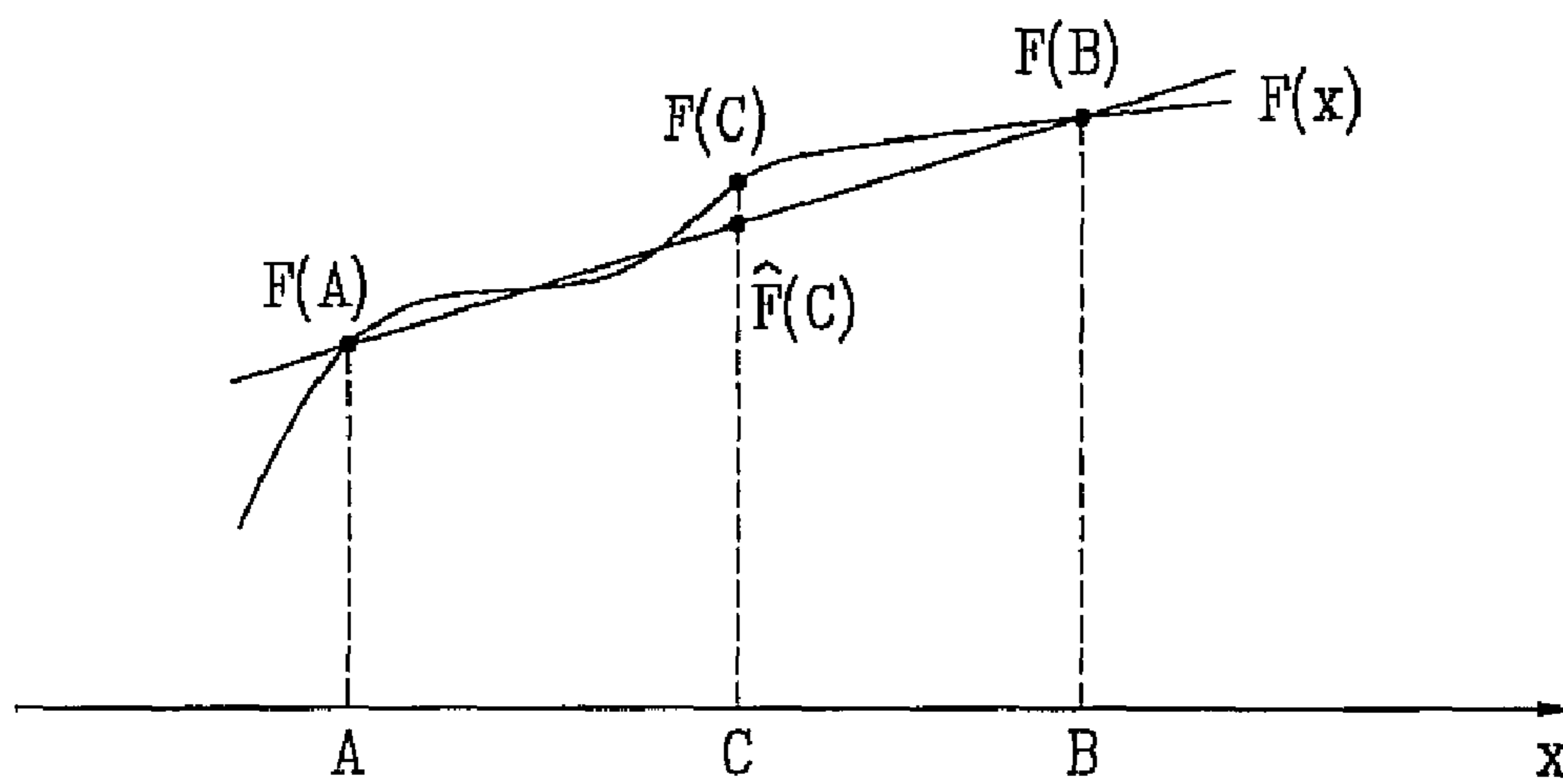

FIG. 6

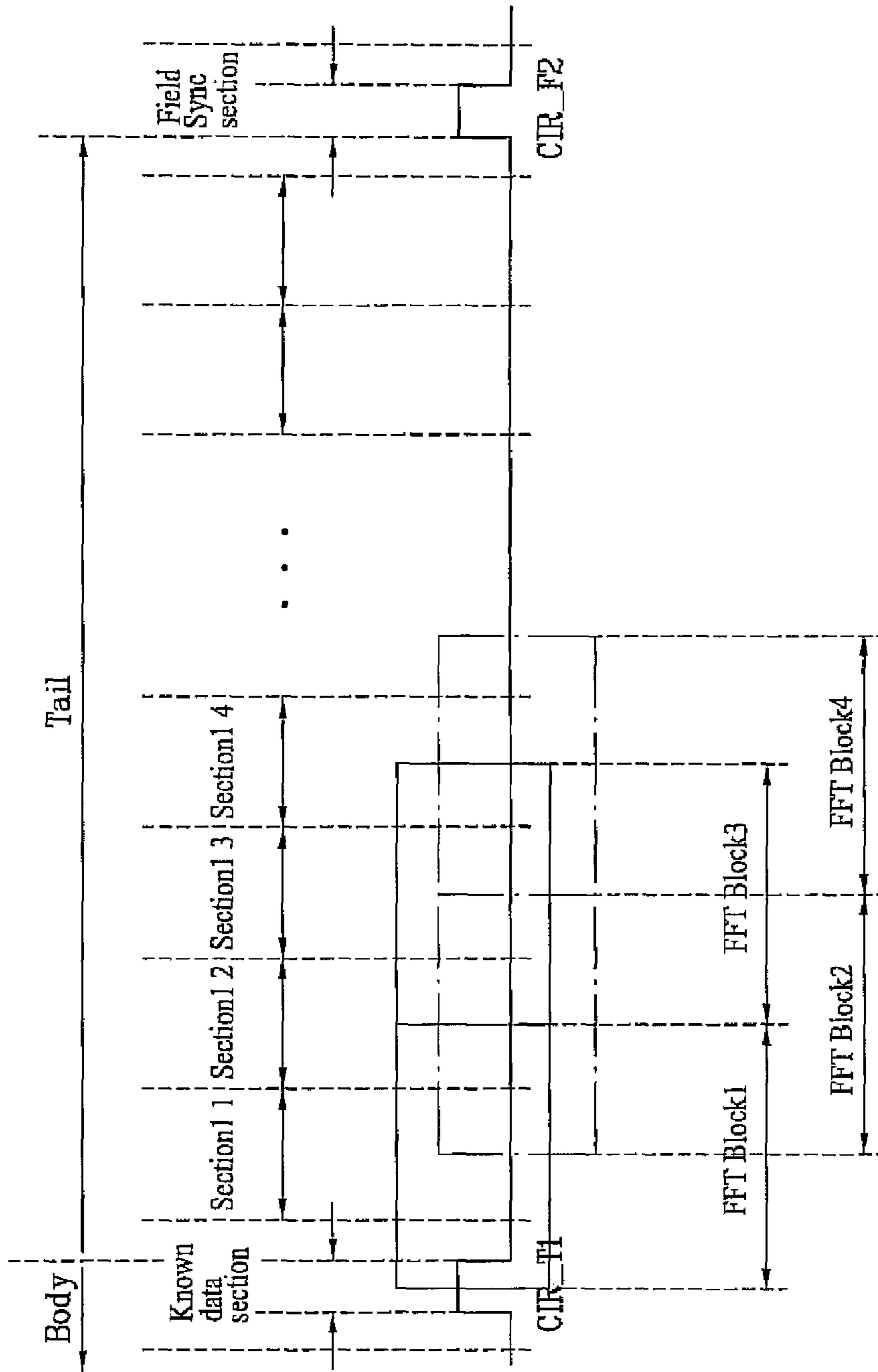

FIG. 7

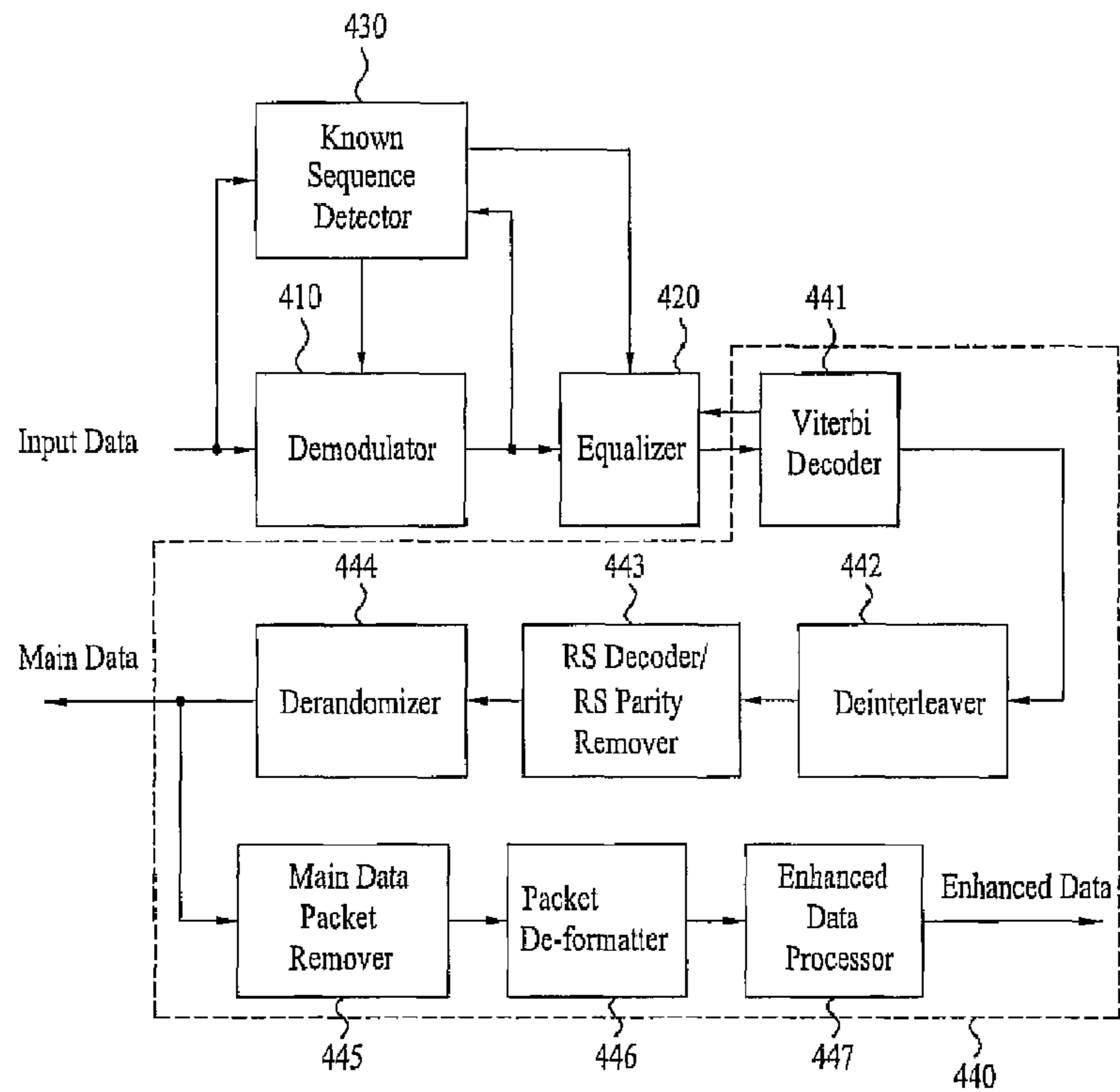

FIG. 8

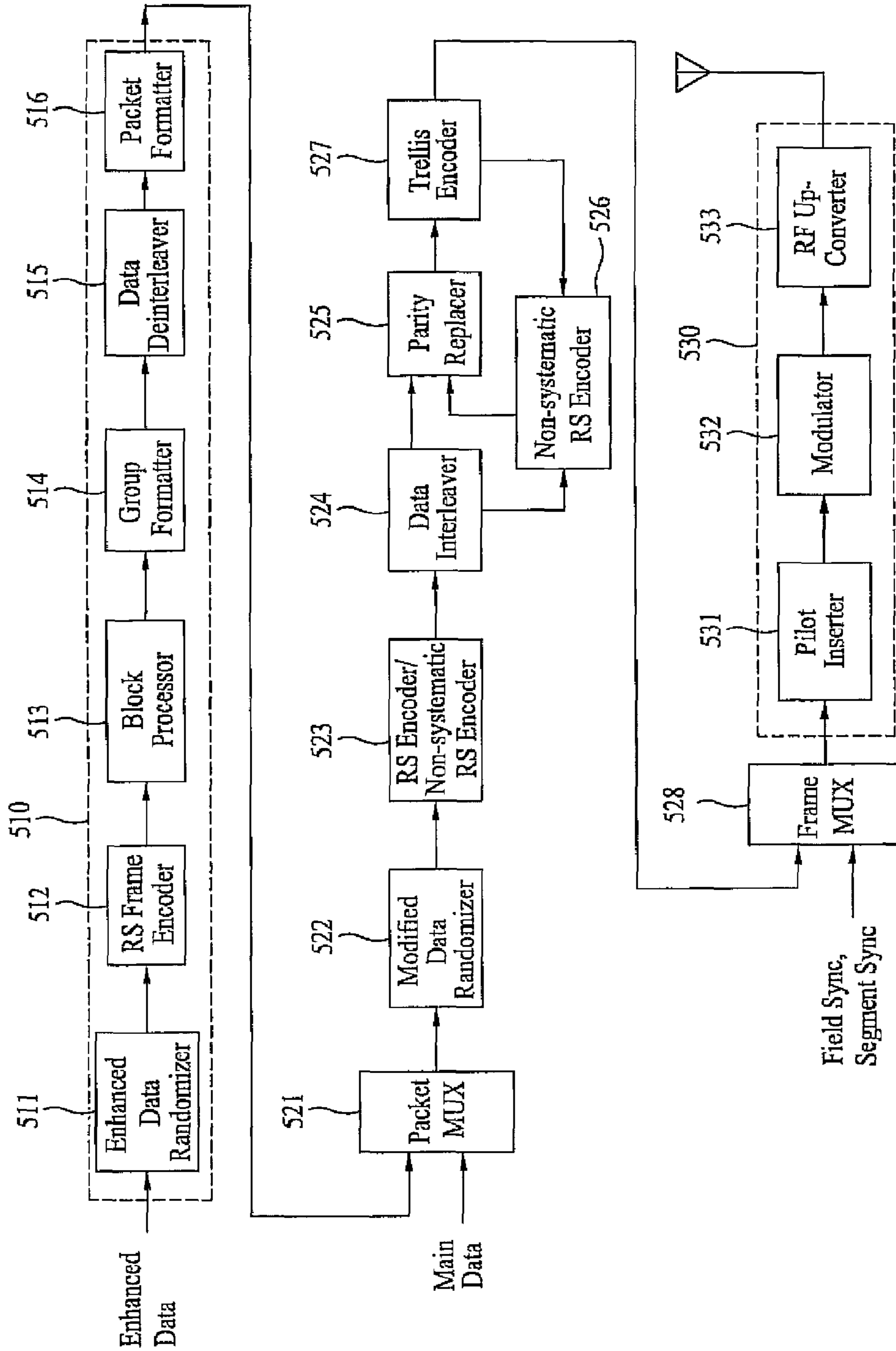

FIG. 9

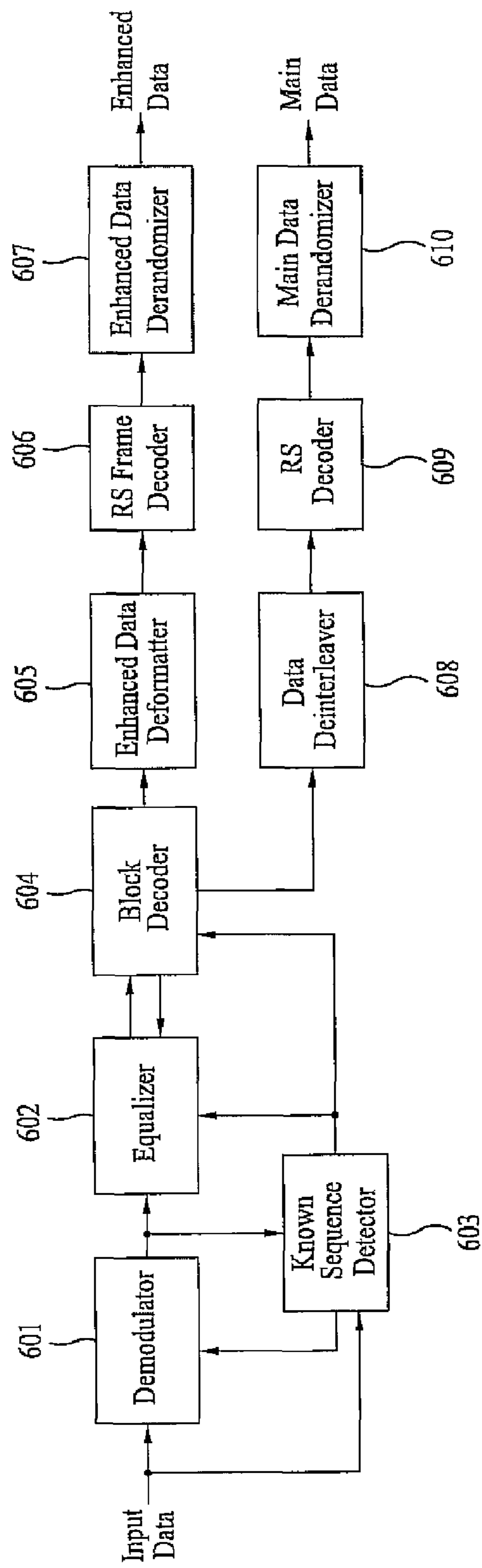

FIG. 10

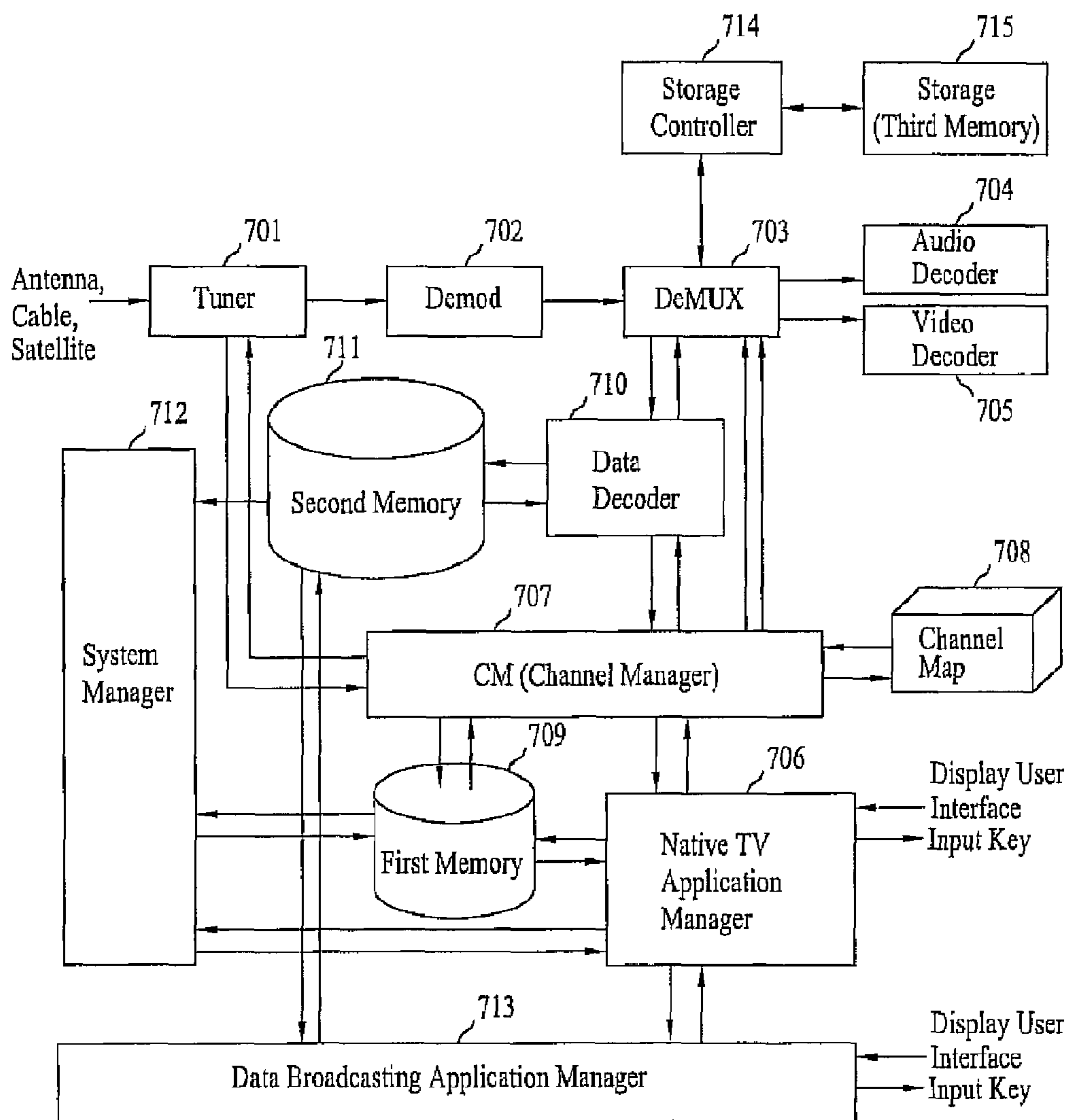
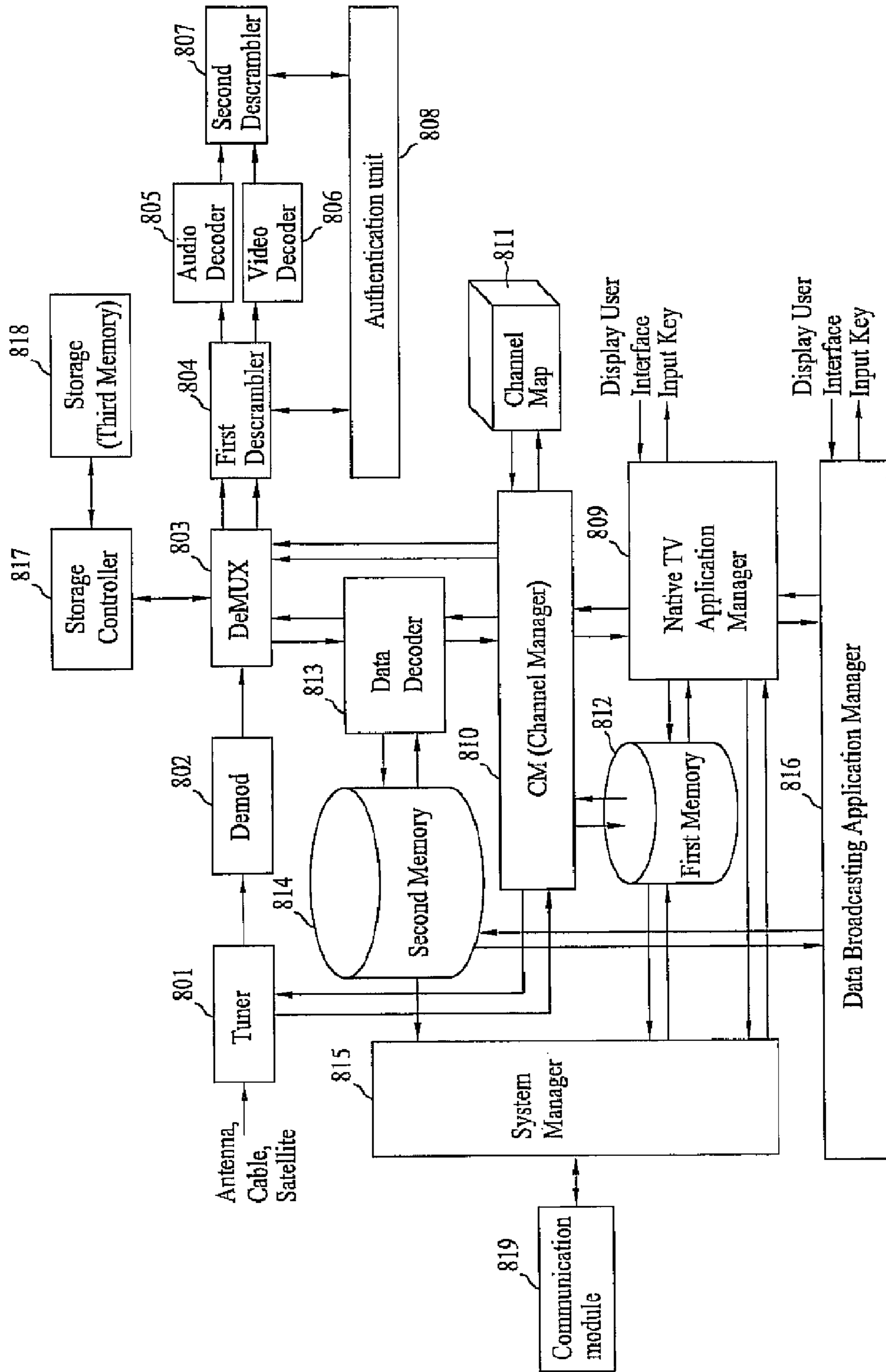

FIG. 11



**CHANNEL EQUALIZER AND METHOD OF
PROCESSING BROADCAST SIGNAL IN
RECEIVING SYSTEM**

Matter enclosed in heavy brackets [] appears in the original patent but forms no part of this reissue specification; matter printed in italics indicates the additions made by reissue; a claim printed with strikethrough indicates that the claim was canceled, disclaimed, or held invalid by a prior post-patent action or proceeding.

CROSS-REFERENCE TO RELATED
APPLICATIONS

This application is a reissue application of U.S. Pat. No. 8,175,196 B2, issued from U.S. application Ser. No. 13/051,851, filed on Mar. 18, 2011, which is a continuation of U.S. application Ser. No. 12/851,376, filed on Aug. 5, 2010, now U.S. Pat. No. 7,933,351, which is a continuation of U.S. application Ser. No. 11/681,554, filed on Mar. 2, 2007, now U.S. Pat. No. 7,796,697, which claims the benefit of earlier filing date and right of priority to Korean Patent Application No. 10-2006-0020140, filed on Mar. 02, 2006 and Korean Patent Application No. 10-2006-0089736, filed on Sep. 15, 2006, and also claims the benefit of U.S. Provisional Application No. 60/883,500, filed on Jan. 4, 2007, the contents of which are all hereby incorporated by reference herein in their entirety. *In addition, more than one reissue application has been filed for the reissue of U.S. Pat. No. 8,175,196 B2. U.S. application Ser. No. 14/306,064, filed on Jun. 16, 2014, currently pending, is a reissue continuation of this reissue application.*

BACKGROUND OF THE INVENTION

1. Field of the Invention

The present invention relates to a digital telecommunications system, and more particularly, to a channel equalizer and a method of processing broadcast signal in a receiving system. Although the present invention is suitable for a wide scope of applications, it is particularly suitable for receiving digital broadcast signal.

2. Discussion of the Related Art

Presently, the technology for processing digital signals is being developed at a vast rate, and, as a larger number of the population uses the Internet, digital electric appliances, computers, and the Internet are being integrated. Therefore, in order to meet with the various requirements of the users, a system that can transmit diverse supplemental information in addition to video/audio data through a digital television channel needs to be developed.

Some users may assume that supplemental data broadcasting would be applied by using a PC card or a portable device having a simple in-door antenna attached thereto. However, when used indoors, the intensity of the signals may decrease due to a blockage caused by the walls or disturbance caused by approaching or proximate mobile objects. Accordingly, the quality of the received digital signals may be deteriorated due to a ghost effect and noise caused by reflected waves. However, unlike the general video/audio data, when transmitting the supplemental data, the data that is to be transmitted should have a low error ratio. More specifically, in case of the video/audio data, errors that are not perceived or acknowledged through the eyes or ears of the user can be ignored, since they do not cause any or much trouble. Conversely, in case of the supplemental data (e.g., program execution file,

stock information, etc.), an error even in a single bit may cause a serious problem. Therefore, a system highly resistant to ghost effects and noise is required to be developed.

The supplemental data are generally transmitted by a time-division method through the same channel as the video/audio data. However, with the advent of digital broadcasting, digital television receiving systems that receive only video/audio data are already supplied to the market. Therefore, the supplemental data that are transmitted through the same channel as the video/audio data should not influence the conventional receiving systems that are provided in the market. In other words, this may be defined as the compatibility of broadcast system, and the supplemental data broadcast system should be compatible with the broadcast system. Herein, the supplemental data may also be referred to as enhanced data. Furthermore, in a poor channel environment, the receiving performance of the conventional receiving system may be deteriorated. More specifically, resistance to changes in channels and noise is more highly required when using portable and/or mobile receiving systems.

SUMMARY OF THE INVENTION

Accordingly, the present invention is directed to a channel equalizer and a method of processing broadcast signal in a receiving system that substantially obviates one or more problems due to limitations and disadvantages of the related art.

An object of the present invention is to provide a channel equalizer and a method of processing broadcast signal in a receiving system that is suitable for receiving supplemental data and that is highly resistant to noise.

A further object of the present invention is to provide a channel equalizer and a method of processing broadcast signal in a receiving system that can use pre-defined known data that are already known by a receiving system and/or a transmitting system, thereby enhancing the receiving performance of the receiving system.

Additional advantages, objects, and features of the invention will be set forth in part in the description which follows and in part will become apparent to those having ordinary skill in the art upon examination of the following or may be learned from practice of the invention. The objectives and other advantages of the invention may be realized and attained by the structure particularly pointed out in the written description and claims hereof as well as the appended drawings.

To achieve these objects and other advantages and in accordance with the purpose of the invention, as embodied and broadly described herein, a channel equalizer for use in a receiving system includes an overlap unit, a first transformer, an estimator, a second transformer, a calculator, a compensator, a third transformer, and a save unit. The overlap unit overlaps a group of data packets in a broadcast signal at a predetermined overlap ratio. The group of data packets has three sections: a head, a body, and a tail. A known data sequence is periodically included in the body section for enhancing channel equalization performance. The first transformer converts the data overlapped by the overlap unit into frequency domain data. The estimator estimates channel impulse responses (CIRs) of data regions in the head, body, and tail, and the second transformer converts the estimated CIRs into frequency domain data. The calculator then calculates equalization coefficients based on the CIRs in the frequency domain, and the compensator compensates channel distortion of the overlapped data in the frequency domain by multiplying the overlapped data with the equalization coeffi-

cients. The third transformer converts the compensated data into time domain data, and the save unit finally saves the compensated data in the time domain.

The estimator estimates a CIR of each data region in the body using the known data sequence. The CIRs of data regions in the head and tail can be obtained in various ways. For example, it may estimate a CIR of a data region in the head or tail by directly using a CIR of a data region in the body adjacent to the head or tail. Alternatively, it may estimate a CIR of a data region in the head or tail by extrapolating CIRs of data regions in the body adjacent to the head or tail. In addition, it may estimate a CIR of a data region in the head or tail by interpolating a CIR of at least one data region in the body adjacent to the head or tail with a CIR of a field sync region which is adjacent to the head or tail.

It is to be understood that both the foregoing general description and the following detailed description of the present invention are exemplary and explanatory and are intended to provide further explanation of the invention as claimed.

BRIEF DESCRIPTION OF THE DRAWINGS

The accompanying drawings, which are included to provide a further understanding of the invention and are incorporated in and constitute a part of this application, illustrate embodiments of the invention and together with the description serve to explain the principle of the invention.

In the drawings:

FIG. 1 illustrates an example of a data frame structure after data interleaving in a transmitting system according to the present invention;

FIG. 2 illustrates a block diagram of a channel equalizer according to an embodiment of the present invention;

FIG. 3 illustrates an example of a linear extrapolation of a channel estimator shown in FIG. 2;

FIG. 4 illustrates an example of estimating a channel impulse response (CIR) by using the linear extrapolation shown in FIG. 3;

FIG. 5 illustrates an example of a linear interpolation of a channel estimator shown in FIG. 2;

FIG. 6 illustrates an example of estimating a channel impulse response (CIR) by using the linear interpolation shown in FIG. 5;

FIG. 7 illustrates a block diagram showing the structure of a demodulating unit included a receiving system according to an embodiment of the present invention;

FIG. 8 illustrates a block diagram of a transmitting system according to another embodiment of the present invention;

FIG. 9 illustrates a block diagram showing a general structure of a demodulating unit within a receiving system according to another embodiment of the present invention;

FIG. 10 illustrates a block diagram showing the structure of a receiving system according to an embodiment of the present invention; and

FIG. 11 illustrates a block diagram showing the structure of a receiving system according to another embodiment of the present invention.

DETAILED DESCRIPTION OF THE INVENTION

Reference will now be made in detail to the preferred embodiments of the present invention, examples of which are illustrated in the accompanying drawings. Wherever possible, the same reference numbers will be used throughout the drawings to refer to the same or like parts. In addition, although the terms used in the present invention are selected

from generally known and used terms, some of the terms mentioned in the description of the present invention have been selected by the applicant at his or her discretion, the detailed meanings of which are described in relevant parts of the description herein. Furthermore, it is required that the present invention is understood, not simply by the actual terms used but by the meaning of each term lying within.

In the present invention, the enhanced data may either consist of data including information such as program execution files, stock information, weather forecast, and so on, or consist of video/audio data. Additionally, the known data refer to data already known based upon a pre-determined agreement between the transmitting system and the receiving system. Furthermore, the main data consist of data that can be received from the conventional receiving system, wherein the main data include video/audio data. The present invention relates to performing channel equalization in a frequency domain by using the known data known already known by the transmitting system and receiving system. More specifically, in the digital broadcast receiving system that multiplexes and transmits the enhanced data having information with the main data, known data known that are already known by the transmitting system and receiving system may be inserted in an enhanced data packet section and then transmitted. In order to enhance the receiving performance, an error correction signal having a higher performance than that of the main data section is applied to the data transmitted from the enhanced data packet section. At this point, the known data may be inserted in the enhanced data packet section in various formats. Additionally, the known data may be used in the digital broadcast receiving system for carrier recovery, frame synchronization recovery, and channel equalization processes.

FIG. 1 illustrates an example of a data frame structure corresponding to the output of a data interleaver (not shown) in a digital broadcast transmitting system according to the present invention. Particularly, FIG. 1 illustrates an example of a predetermined number of data packets gathered (or grouped) so as to be divided in to head, body, and tail areas. More specifically, FIG. 1 shows an example of a single field being divided into the head, body, and tail areas. With respect to the output of the data interleaves, the body area is allocated to include at least a portion or the entire area in which enhanced data are consecutively outputted. In the body area, the known data are periodically inserted at a constant rate. The head area is located before the body area, and the tail area is located after the body area. Referring to FIG. 1, the main data are not included in the body area.

In this case, the body area may show a stronger receiving performance, since there is no interference from the main data. The enhanced data of the head and tail areas are mixed with the main data in accordance with the output order from the interleaves. Accordingly, the receiving performance in the head and tail areas is more deteriorated than in the body area. Therefore, when known data are inserted in the enhanced data and then transmitted, and when consecutive and long known data re to be periodically inserted in the enhanced data, the known data may be inserted in the body area. This is because, based upon the output order of the data interleaver, the enhanced data are not mixed with the main data. At this point, known data having a predetermined length may be periodically inserted in the body area. However, it is difficult to periodically insert known data in the head and tail areas, and it is also difficult to insert consecutive and long known data.

At this point, in the body area, the known data are allocated in accordance with a constant cycle (or period). Therefore, known data may be used to estimate a channel impulse response (CIR) or also be used to perform channel equaliza-

tion with stability. Unlike in the body area, sufficiently long known data cannot be inserted periodically in the head and tail areas. Therefore, it is difficult to estimate the CIR using the known data in the head and tail areas. Eventually, the equalization performance becomes deteriorated in the head and tail areas. The present invention relates to enhancing the equalization performance in the head and tail areas. The method of the same will be described in detail according to a plurality of embodiments of the present invention.

First Embodiment

The first embodiment of the present invention relates to directly copying the CIR estimated from the body area and using the copied CIR for the channel equalization process in the head/tail areas. More specifically, when the head/tail areas and the body area are assumed to be similar to one another due to non-frequent channel change based upon a predetermined time interval, the CIR of the body area may be directly used (i.e., without modification) in the head/tail areas adjacent to the corresponding body area. For example, in order to perform the channel equalization process in the head area, the CIR estimated from the body area adjacent to the corresponding head area may be used. And, in order to perform the channel equalization process in the tail area, the CIR estimated from the body area adjacent to the corresponding tail area may be used.

FIG. 2 illustrates a block diagram showing an example of the channel equalizer using such method (or such CIR) according to the first embodiment of the present invention. Herein, an overlap & save method is used to perform linear convolutional operation in the frequency domain. Referring to FIG. 2, the channel equalizer includes a buffer 201, an overlap unit 202, a first fast fourier transform (FFT) unit 203, a distortion compensator 204, an inverse fast fourier transform (IFFT) unit 205, a save unit 206, a channel estimator 207, a second FFT unit 208, and a MMSE coefficient calculator 209. Herein, any device performed complex number multiplication may be used as the distortion compensator 204.

In the channel equalizer having the above-described structure, as shown in FIG. 2, the buffer 201 delays the received data to a specific time so as to synchronize the received data with the CIR. Thereafter, the buffer 201 outputs the delayed data to the overlap unit 202. The overlap unit 202 overlaps the input data to a pre-determined overlapping ratio, which are then outputted to the first FFT unit 203. The first FFT unit 203 converts (or transforms) the overlapped data of the time domain to overlapped data of the frequency domain by using fast fourier transform (FFT). Then, the converted data are outputted to the distortion compensator 204. The distortion converter 204 performs complex multiplication on the equalization coefficient calculated from the MMSE coefficient calculator 209 and the overlapped data of the frequency domain, thereby compensating the channel distortion of the overlapped data being outputted from the first FFT unit 203. Thereafter, the distortion-compensated data are outputted to the IFFT unit 205. The IFFT unit 205 performs inverse fast fourier transform (IFFT) on the distortion-compensated overlapped data, so as to convert the corresponding data back to data (i.e., overlapped data) of the time domain. Thereafter, the converted data are outputted to the save unit 206. The save unit 206 extracts only the valid data from the overlapped data of the time domain, thereby outputting the extracted valid data.

Meanwhile, the channel estimator 207 estimates the CIR by using the received data and the known data, the known data being already known by the receiving system in accordance with an agreement between the receiving system and the

transmitting system. Then, the estimated CIR is outputted to the second FFT unit 208. In the head/tail areas, the CIR of the adjacent body area is outputted to the second FFT unit 208. At this point, since the head area is positioned before the body area, the buffer 201 should delay the received data until the CIR of the body area is estimated by the channel estimator 207 in order to allow the CIR of the body area to be used in the head area. For example, the CIRs of the body area located near the head area, as shown in FIG. 1, are referred to as CIR_H1, CIR_H2, CIR_H3, . . . , respectively. Alternatively, the CIRs of the body area located near the tail area are referred to as CIR_T1, CIR_T2, CIR_T3, . . . , respectively. Accordingly, the channel estimator 207 outputs CIR_H1 from the head area, and the channel estimator 207 sequentially outputs CIR_H1, CIR_H2, CIR_H3, . . . , CIR_T3, CIR_T2, and CIR_H1 from the body area. The channel estimator 207 then outputs CIR_T1 from the tail area. The CIRs that are outputted from the channel estimator 207 are inputted to the second FFT unit 208, which are then converted to CIRs of the frequency domain and inputted to the MMSE coefficient calculator 209.

The MMSE coefficient calculator 209 uses the CIR of the frequency domain, so as to calculate the equalization coefficient and to output the calculated equalization coefficient to the distortion compensator 204. The MMSE coefficient calculator 209 is an exemplary part of the channel equalizer according to the first embodiment of the present invention. At this point, the MMSE coefficient calculator 209 calculates a channel equalization coefficient of the frequency domain that can provide minimum mean square error (MMSE) from the CIR of the frequency domain. The calculated channel equalization coefficient is outputted to the distortion compensator 204. More specifically, the MMSE coefficient calculator 209 uses the CIR of the frequency domain so as to calculate the channel equalizer coefficient of the frequency domain with minimum mean square error (MMSE).

Second Embodiment

The second embodiment of the present invention relates to performing extrapolation on the CIR of the body area so as to use the extrapolated CIR for the channel equalization of the head/tail areas. Herein, when a value $F(A)$ of a function $F(x)$ at a particular point A and a value $F(B)$ of the function $F(x)$ at another particular point B are known, an extrapolation refers to estimating a function value of a point outside of the section between points A and B.

FIG. 3 illustrates an example of an extrapolation operation. Particularly, FIG. 3 illustrates the simplest form of linear extrapolation among a wide range of extrapolation operations. More specifically, since the values $F(A)$ and $F(B)$ each from points A and B, respectively, are known, a straight line passing between the A-B section may be obtained so as to calculate an approximate value $F(G)$ of the $F(x)$ function at point C. Herein, the equation of the straight line passing the coordinates $(A, F(A))$ and $(B, F(B))$ is shown in Equation 1 below:

$$\hat{F}(x) = \frac{F(B) - F(A)}{B - A}(x - A) + F(A) \quad \text{Equation 1}$$

Therefore, in order to calculate the function value at point C using Equation 1, the equation shown in Equation 2 below may be used.

$$\hat{F}(C) = \frac{F(B) - F(A)}{B - A}(C - A) + F(A) \quad \text{Equation 2}$$

The above-described linear extrapolation method is the simplest form of linear extrapolation among a wide range of extrapolation operations. However, the method described above is merely exemplary, and, therefore, the present invention is not limited only to the example presented above. Accordingly, a variety of other extrapolation may be used in the present invention. Herein, by using the above-described linear extrapolation method, the CIR of the head/tail areas may be estimated. More specifically, by computing extrapolation of the CIR that has been obtained from the known data of adjacent head/tail areas, the CIR of the head/tail areas may be estimated.

FIG. 4 illustrates a conceptual diagram of the extrapolation operation according to the present invention. Most particularly, in the example of the extrapolation operation shown in FIG. 4, data of a current FFT block and data of a previous FFT block are overlapped at an overlapping ratio of 50%, then the head/tail areas are divided into a plurality of sections so that the CIR of each section is estimated by performing (or operating) extrapolation on the CIRs of the body area. More specifically, the CIR of each section of the head/tail areas is estimated by performing extrapolation on at least one of the CIRs of the body area. Then, by using each of the estimated CIRs, channel equalization is performed on the data corresponding to each section. When extrapolation is performed on CIR_T1 and CIR_T2 of the body area, in order to estimate the CIRs of section 1 to section 4 of the tail area, and when the length of one section is assumed to be equal to 4 segments, the CIRs of section 1 to section 4 having linear extrapolation performed thereon are as follows:

Section 1: $1.25 * \text{CIR_T1} - 0.25 * \text{CIR_T2}$

Section 2: $1.5 * \text{CIR_T1} - 0.5 * \text{CIR_T2}$

Section 3: $1.75 * \text{CIR_T1} - 0.75 * \text{CIR_T2}$

Section 4: $2 * \text{CIR_T1} - \text{CIR_T2}$

When channel equalization is performed by using the above-described extrapolation method, the channel equalizer shown in FIG. 2 is operated as described below.

More specifically, the input data of the equalizer pass through the buffer 201 and are synchronized with the CIRs of each section that are estimated by the channel estimator 207. Thereafter, the synchronized data are outputted to the overlap unit 202. The overlap unit 202 overlaps the input data to a predetermined overlapping ratio and then outputs the overlapped data to the first FFT unit 203. The first FFT unit 203 converts the overlapped data to frequency domain data and outputs the converted data to the distortion compensator 204. The distortion compensator 204 multiplies the data of the frequency domain with the channel equalizer coefficient of the frequency domain that is outputted from the MMSE coefficient calculator 209. Subsequently, the distortion compensator 204 compensates for the channel distortion included in the data of the frequency domain. Thereafter, the distortion compensated data are outputted to the IFFT unit 205. The IFFT unit 205 performs IFFT on the equalized overlapped data so as to convert the data back to time frequency data. The converted data are then outputted to the save unit 206. The save unit 206 extracts only the valid data from the equalized overlapped data of the time frequency data. Then, the final data are outputted.

Meanwhile, the channel estimator 207 estimates the CIR in the body area by using the received data and the known data

that are known by the receiving system in accordance with an agreement between the receiving system and the transmitting system. The channel estimator 207 also estimates the CIRs in the head/tail areas by performing extrapolation on the estimated CIRs of the body area. The estimated CIRs are inputted to the second FFT unit 208. More specifically, the channel estimator 207 estimates each of the CIRs corresponding to the head/body/tail areas differently. For example, in the head area, extrapolation is performed on the CIRs of the body area (i.e., CIR_H1, CIR_H2, CIR_H3), which is adjacent to the head area, thereby outputting the estimated CIRs. Alternatively, the CIRs being estimated by using the known data are outputted from the body area. Furthermore, in the tail area, extrapolation is performed on the CIRs of the body area (i.e., CIR_T1, CIR_T2, CIR_T3), which is adjacent to the tail area, thereby outputting the estimated CIRs. The second FFT unit 208 receives the CIRs and performs FFT on the received CIRs, thereby converting the received CIRs to frequency domain data. Then, the converted data are outputted to the MMSE coefficient calculator 209. Thereafter, the MMSE coefficient calculator 209 uses the CIR of the frequency domain so as to calculate the channel equalizer coefficient of the frequency domain with minimum mean square error (MMSE). Then, the calculated MMSE coefficient is outputted to the distortion compensator 204.

Third Embodiment

The third embodiment of the present invention relates to performing interpolation on the CIR of the body area and the CIR estimated by using field synchronization data so as to estimate a CIR, which is then used to perform channel equalization of the head/tail areas. More specifically, as shown in FIG. 1, a set of field synchronization data for synchronization recovery of a frame having the length of a segment is included in each field of the transmitted frame, which is transmitted from the transmitting system. In the present invention, the field synchronization data may be used to calculate the CIR. Then, interpolation is performed on the CIR obtained from the body area and the CIR obtained from the field synchronization section, thereby enabling the CIR of the head/tails area to be estimated. Herein, when a value $F(A)$ of a function $F(x)$ at a particular point A and a value $F(B)$ of the function $F(x)$ at another particular point B are known, an interpolation refers to estimating a function value of a point within the section between points A and B.

FIG. 5 illustrates an example of an interpolation operation, which is the simplest form of linear interpolation among a wide range of interpolation operations. More specifically, in a random function $F(x)$, when given the values $F(A)$ and $F(B)$ each from points $x=A$ and $x=B$, respectively, the estimated value $\hat{F}(C)$ of the $F(x)$ function at point $x=C$ may be estimated by using Equation 3 below.

$$\hat{F}(C) = \frac{F(B) - F(A)}{B - A}(C - A) + F(A) \quad \text{Equation 3}$$

$$\hat{F}(C) = \frac{B - C}{B - A}F(A) + \frac{C - A}{B - A}F(B)$$

The above-described linear interpolation method is the simplest form of linear interpolation among a wide range of interpolation operations. However, the method described above is merely exemplary, and, therefore, the present invention is not limited only to the example presented above. Accordingly, a variety of other interpolation may be used in the present invention. Herein, by using the above-described linear interpolation method, the CIR of the head/tail areas

may be estimated. More specifically, by performing interpolation of the CIR that has been obtained from the known data of adjacent head/tail areas and the CIR that has been obtained from the field synchronization section, the CIR of the head/tail areas may be estimated.

FIG. 6 illustrates a conceptual diagram of the interpolation operation according to the present invention. Most particularly, in the example of the interpolation operation shown in FIG. 6, data of a current FFT block and data of a previous FFT block are overlapped at an overlapping ratio of 50%, then the head/tail areas are divided into a plurality of sections. Thereafter, the CIR of each section is estimated by performing (or operating) interpolation on the CIRs of the body area and the CIRs of the field synchronization section. When interpolation is performed on CIR_T1 (i.e., the CIR of the body area) and CIR_F2 (i.e., the CIR of the field synchronization section), in order to estimate the CIRs of section 1 to section 4 of the tail area, and when the length of one section is assumed to be equal to 4 segments and the length of the tail area is assumed to be equal to 52 segments, the CIRs of section 1 to section 4 having linear interpolation performed thereon are as follows:

Section 1: $(49 \cdot \text{CIR_T1} - 4 \cdot \text{CIR_F2}) / 53$

Section 2: $(45 \cdot \text{CIR_T1} - 8 \cdot \text{CIR_F2}) / 53$

Section 3: $(41 \cdot \text{CIR_T1} - 12 \cdot \text{CIR_F2}) / 53$

Section 4: $(37 \cdot \text{CIR_T1} - 16 \cdot \text{CIR_F2}) / 53$

When channel equalization is performed by using the above-described interpolation method, the channel equalizer shown in FIG. 2 is operated as described below.

More specifically, the input data of the equalizer pass through the buffer 201 and are synchronized with the CIRs of each section that are estimated by the channel estimator 207. Thereafter, the synchronized data are outputted to the overlap unit 202. The overlap unit 202 overlaps the input data to a predetermined overlapping ratio and then outputs the overlapped data to the first FFT unit 203. The first FFT unit 203 converts the overlapped data to frequency domain data and outputs the converted data to the distortion compensator 204. The distortion compensator 204 multiplies the data of the frequency domain with the channel equalizer coefficient of the frequency domain that is outputted from the MMSE coefficient calculator 209. Subsequently, the distortion compensator 204 compensates for the channel distortion included in the data of the frequency domain. Thereafter, the distortion compensated data are outputted to the IFFT unit 205. The IFFT unit 205 performs IFFT on the equalized overlapped data so as to convert the data back to time frequency data. The converted data are then outputted to the save unit 206. The save unit 206 extracts only the valid data from the equalized overlapped data of the time frequency data. Then, the final data are outputted.

Meanwhile, the channel estimator 207 estimates the CIR in the body area by using the received data and the known data that are known by the receiving system in accordance with an agreement between the receiving system and the transmitting system. The channel estimator 207 also estimates the CIRs in the head/tail areas by performing interpolation on the CIRs of the body area and the CIRs of the field synchronization section. The estimated CIRs are inputted to the second FFT unit 208. More specifically, the channel estimator 207 estimates each of the CIRs corresponding to the head/body/tail areas differently. For example, in the head area, interpolation is performed on the CIRs of the body area (i.e., CIR_H1, CIR_H2, CIR_H3), which is adjacent to the head area, and the CIR of the field synchronization section (i.e., CIR_F1), thereby outputting the estimated CIRs. Alternatively, the CIRs being estimated by using the known data are outputted

from the body area. Furthermore, in the tail area, interpolation is performed on the CIRs of the body area (i.e., CIR_T1, CIR_T2, CIR_T3), which is adjacent to the tail area, and the CIR of the field synchronization section (i.e., CIR_F2), thereby outputting the estimated CIRs. The second FFT unit 208 receives the CIRs and performs FFT on the received CIRs, thereby converting the received CIRs to frequency domain data. Then, the converted data are outputted to the MMSE coefficient calculator 209. Thereafter, the MMSE coefficient calculator 209 uses the CIR of the frequency domain so as to calculate the channel equalizer coefficient of the frequency domain with minimum mean square error (MMSE). Then, the calculated MMSE coefficient is outputted to the distortion compensator 204.

FIG. 7 illustrates an example of a demodulating unit included in a digital broadcast receiving system having the above-described channel equalizer adopted therein. The demodulating unit shown in FIG. 7 is merely an example given to simplify the understanding of the present invention. Any demodulating unit that can adopt the above-described channel equalization method may be used in the present invention. Therefore, the embodiments of the present invention are not limited to the examples set forth herein.

Referring to FIG. 7, the demodulating unit includes a demodulator 410, a channel equalizer 420, a known sequence detector 430, and an error correction unit 440. Herein, the error correction unit 440 includes a Viterbi decoder 441, a data deinterleaver 442, a RS decoder/non-systematic RS parity remover 443, a derandomizer 444, a main data packet remover 445, a packet deformatter 446, and an enhanced data processor 447. More specifically, a frequency that is received through a particular channel is tuned and digitalized so as to be outputted to the demodulator 410 and the known sequence detector 430. The demodulator 410 uses the known data on the tuned channel frequency so as to perform carrier recovery and timing recovery, thereby create baseband signals. Thereafter, the baseband signals are outputted to the channel equalizer 420 and the known sequence detector 430.

The channel equalizer 420 uses any one of the methods presented according to the first to third embodiments of the present invention so as to estimate the CIR. Then, the channel equalizer 420 uses the estimated CIR to compensate for the distortion occurring in the channel including the demodulated signals. Thereafter, the distortion-compensated data are outputted to the error correction unit 440. More specifically, when a plurality of enhanced data packets are respectively transmitted to hierarchically divided head, body, and tail areas, the CIRs corresponding to each of the head/body/tail areas are estimated in accordance with the information of each area. Then, channel equalization is performed using the estimated CIRs.

At this point, in the body area, channel equalization may be performed by using the CIR, which is, estimated by using the known data. In the head area, channel equalization may be performed by estimating the CIR by adopting any of the methods described in the first to third embodiments of the present invention. Further, in the tail area, channel equalization may be performed by estimating the CIR by adopting any of the methods described in the first to third embodiments of the present invention. Herein, the same method according to any of the three embodiments of the present invention may be used in the head area and the tail area. Conversely, different method may also be used in each of the head and tail areas. For example, the method described in the second embodiment according to the present invention may be identically adopted in the head/tail areas. Then, the channel equalization process may be performed by using the CIRs estimated by

performing extrapolation on the CIRs of the body area, which is adjacent to the corresponding areas. In another example, the channel equalization process may also be performed by using the CIR estimated according to the second embodiment of the present invention in the head area, and by also using the CIR estimated according to the third embodiment of the present invention in the tail area.

The known data detector and generator **440** detects the known data, which have been inserted from the transmitting system, from the input/output data of the demodulator **410** (i.e., the data prior to demodulation or the data after demodulation). Thereafter, the detected known data are outputted to the demodulator **410** and the channel equalizer **420**. The Viterbi decoder **441** of the error correction unit **440** Viterbi-decodes the data that are outputted from the channel equalizer **420**. At this point, the 8-level decision values decided by the Viterbi decoder **441** are provided to the channel equalizer **420**, thereby enhancing the equalizing performance. The data deinterleaver **442** performs an inverse process of the data interleaver included in the transmitting system on the input data. Thereafter, the data deinterleaver **442** outputs the deinterleaved data to the RS decoder/non-systematic RS parity remover **443**. If the received data packet corresponds to the main data packet, the RS decoder/non-systematic RS parity remover **443** performs a systematic RS decoding process. Alternatively, if the received data packet corresponds to the enhanced data packet, the RS decoder/non-systematic RS parity remover **443** removes the non-systematic RS parity byte that has been inserted in the enhanced data packet. Thereafter, the RS decoder/non-systematic RS parity remover **443** outputs the processed data to the derandomizer **444**.

The derandomizer **444** performs a derandomizing process on the output of the RS decoder/non-systematic RS parity remover **443**. Afterwards, the derandomizer **444** inserts a MPEG synchronization byte at the beginning of each packet so as to output the processed data in 188-byte packet units. The output of the derandomizer **444** is outputted to the main MPEG decoder (not shown) and to the main data packet remover **445** at the same time. Meanwhile, the main data packet remover **445** removes a 188-byte unit main data packet from the output of the derandomizer **444** and outputs the processed data to the packet deformatter **446**. The packet deformatter **446** removes the MPEG header, which was inserted to the enhanced data packet by the transmitting system, and the known data from the enhanced data packet outputted from the main data packet remover **445**. The processed enhanced data packet is then outputted to the enhanced data processor **447**. The enhanced data processor **447** performs null data removing, additional error correction coding, and deinterleaving processes on the output of the packet deformatter **446**. Thus, the finally processed enhanced data are outputted.

FIG. 8 illustrates a block diagram showing the structure of a digital broadcast transmitting system according to an embodiment of the present invention. The digital broadcast transmitting system includes a pre-processor **510**, a packet multiplexer **521**, a data randomizer **522**, a Reed-Solomon (RS) encoder/non-systematic RS encoder **523**, a data interleaver **524**, a parity byte replacer **525**, a non-systematic RS encoder **526**, a frame multiplexer **528**, and a transmitting unit **530**. The pre-processor **510** includes an enhanced data randomizer **511**, a RS frame encoder **512**, a block processor **513**, a group formatter **514**, a data deinterleaver **515**, and a packet formatter **516**.

In the present invention having the above-described structure, main data are inputted to the packet multiplexer **521**.

Enhanced data are inputted to the enhanced data randomizer **511** of the pre-processor **510**, wherein an additional coding process is performed so that the present invention can respond swiftly and appropriately against noise and change in channel. The enhanced data randomizer **511** randomizes the received enhanced data and outputs the randomized enhanced data to the RS frame encoder **512**. At this point, by having the enhanced data randomizer **511** perform the randomizing process on the enhanced data, the randomizing process on the enhanced data by the data randomizer **522** in a later process may be omitted. Either the randomizer of the conventional broadcast system may be used as the randomizer for randomizing the enhanced data, or any other type of randomizer may be used herein.

The RS frame encoder **512** receives the randomized enhanced data and performs at least one of an error correction coding process and an error detection coding process on the received data. Accordingly, by providing robustness to the enhanced data, the data can scatter group error that may occur due to a change in the frequency environment. Thus, the data can respond appropriately to the frequency environment which is very poor and liable to change. The RS frame multiplexer **512** also includes a process of mixing in row units many sets of enhanced data each having a pre-determined size. By performing an error correction coding process on the inputted enhanced data, the RS frame encoder **512** adds data required for the error correction and, then, performs an error detection coding process, thereby adding data required for the error detection process. The error correction coding uses the RS coding method, and the error detection coding uses the cyclic redundancy check (CRC) coding method. When performing the RS coding process, parity data required for the error correction are generated. And, when performing the CRC coding process, CRC data required for the error detection are generated.

The RS frame encoder **512** performs CRC coding on the RS coded enhanced data in order to create the CRC code. The CRC code that is generated by the CRC coding process may be used to indicate whether the enhanced data have been damaged by an error while being transmitted through the channel. The present invention may adopt other types of error detection coding methods, apart from the CRC coding method, and may also use the error correction coding method so as to enhance the overall error correction ability of the receiving system. For example, assuming that the size of one RS frame is $187 \cdot N$ bytes, that $(235, 187)$ -RS coding process is performed on each column within the RS frame, and that a CRC coding process using a 2-byte (i.e., 16-bit) CRC checksum, then a RS frame having the size of $187 \cdot N$ bytes is expanded to a RS frame of $235 \cdot (N+2)$ bytes. The RS frame expanded by the RS frame encoder **512** is inputted to the block processor **513**. The block processor **513** codes the RS-coded and CRC-coded enhanced data at a coding rate of G/H . Then, the block processor **513** outputs the G/H -rate coded enhanced data to the group formatter **514**. In order to do so, the block processor **513** identifies the block data bytes being inputted from the RS frame encoder **512** as bits.

The block processor **513** may receive supplemental information data such as signaling information, which include information on the system, and identifies the supplemental information data bytes as data bits. Herein, the supplemental information data, such as the signaling information, may equally pass through the enhanced data randomizer **511** and the RS frame encoder **512** so as to be inputted to the block processor **513**. Alternatively, the supplemental information data may be directly inputted to the block processor **513** without passing through the enhanced data randomizer **511**.

13

and the RS frame encoder **512**. The signaling information corresponds to information required for receiving and processing data included in the data group in the receiving system. Such signaling information includes data group information, multiplexing information, and burst information.

As a G/H-rate encoder, the block processor **513** codes the inputted data at a coding rate of G/H and then outputs the G/H-rate coded data. For example, if 1 bit of the input data is coded to 2 bits and outputted, then G is equal to 1 and H is equal to 2 (i.e., G=1 and H=2). Alternatively, if 1 bit of the input data is coded to 4 bits and outputted, then G is equal to 1 and H is equal to 4 (i.e., G=1 and H=4). As an example of the present invention, it is assumed that the block processor **513** performs a coding process at a coding rate of 1/2 (also referred to as a 1/2-rate coding process) or a coding process at a coding rate of 1/4 (also referred to as a 1/4-rate coding process). More specifically, the block processor **513** codes the received enhanced data and supplemental information data, such as the signaling information, at either a coding rate of 1/2 or a coding rate of 1/4. Thereafter, the supplemental information data, such as the signaling information, are identified and processed as enhanced data.

Since the 1/4-rate coding process has a higher coding rate than the 1/2-rate coding process, greater error correction ability may be provided. Therefore, in a later process, by allocating the 1/4-rate coded data in an area with deficient receiving performance within the group formatter **514**, and by allocating the 1/2-rate coded data in an area with excellent receiving performance, the difference in the overall performance may be reduced. More specifically, in case of performing the 1/2-rate coding process, the block processor **513** receives 1 bit and codes the received 1 bit to 2 bits (i.e., 1 symbol). Then, the block processor **513** outputs the processed 2 bits (or 1 symbol). On the other hand, in case of performing the 1/4-rate coding process, the block processor **513** receives 1 bit and codes the received 1 bit to 4 bits (i.e., 2 symbols). Then, the block processor **513** outputs the processed 4 bits (or 2 symbols). Additionally, the block processor **513** performs a block interleaving process in symbol units on the symbol-coded data. Subsequently, the block processor **513** converts to bytes the data symbols that are block-interleaved and have the order rearranged.

The group formatter **514** inserts the enhanced data outputted from the block processor **513** (herein, the enhanced data may include supplemental information data such as signaling information including transmission information) in a corresponding area within the data group, which is configured according to a pre-defined rule. Furthermore, in relation with the data deinterleaving process, various types of places holders or known data are also inserted in corresponding areas within the data group. At this point, the data group may be described by at least one hierarchical area. Herein, the data allocated to the each area may vary depending upon the characteristic of each hierarchical area. Additionally, each group is configured to include a field synchronization signal.

The present invention shows an example of the data group being divided into three hierarchical areas: a head area, a body area, and a tail area. Accordingly, in the data group that is inputted for the data deinterleaving process, data are first inputted to the head area, then inputted to the body area, and inputted finally to the tail area. In the example of the present invention, the head, body, and tail areas are configured so that the body area is not mixed with the main data area within the data group. Furthermore, in the present invention, the head, body, and tail areas may each be divided into lower hierarchical areas. For example, the head area may be divided into 3 lower hierarchical areas: a far head (FH) area, a middle head

14

(MH) area, and a near head (NH) area. The body area may be divided into 4 lower hierarchical areas: a first lower body (B1) area, a second lower body (B2) area, a third lower body (B3) area, and a fourth lower body (B4) area. And, finally, the tail area may be divided into 2 lower hierarchical areas: a far tail (FT) area and a near tail (NT) area.

In the example of the present invention, the group formatter **514** inserts the enhanced data being outputted from the block processor **513** to the middle head (MH) area, the near head (NH) area, the first to fourth lower body (B1 to B4) areas, and the near tail (NT) area. Herein, the type of enhanced data may vary depending upon the characteristic of each area. The data group is divided into a plurality of areas so that each area may be used for different purposes. More specifically, areas having less interference with the main data may show more enhanced receiving performance as compared with area having more interference with the main data. Additionally, when using the system in which the known data are inserted in the data group and then transmitted, and when a long set of consecutive known data is to be periodically (or regularly) inserted in the enhanced data, the body area is capable of regularly receiving such enhanced data having a predetermined length. However, since the enhanced data may be mixed with the main data in the head and tail areas, it is difficult to regularly insert the known data in these areas, and it is also difficult to insert long known data sets that are consecutive in these areas.

Details such as the size of the data group, the number of hierarchical areas within the data group and the size of each hierarchical area, and the number of enhanced data bytes that may be inserted in each hierarchical area may vary depending upon the design of the system designer. Therefore, the above-described embodiment is merely an example that can facilitate the description of the present invention. In the group formatter **514**, the data group may be configured to include a position (or place) in which the field synchronization signal is to be inserted. When assuming that the data group is divided into a plurality of hierarchical areas as described above, the block processor **513** may code the data that are to be inserted in each area at different coding rates.

In the present invention, based upon the areas that are each expected to show different performance after the equalization process when using the channel information that may be used for the channel equalization process in the receiving system, a different coding rate may be applied to each of these areas. For example, the block processor **513** codes the enhanced data that are to be inserted in the near head (NH) area and the first to fourth lower body (B1 to B4) areas at a 1/2-coding rate. Thereafter, the group formatter **514** may insert the 1/2-rate coded enhanced data in the near head (NH) area and the first to fourth lower body (B1 to B4) areas. On the other hand, the block processor **513** codes the enhanced data that are to be inserted in the middle head (MH) area and the near tail (NT) area at a 1/4-coding rate, which has greater error correction ability than the 1/2-coding rate. Subsequently, the group formatter **514** may insert the 1/2-rate coded enhanced data in the middle head (MH) area and the near tail (NT) area. Furthermore, the block processor **513** codes the enhanced data that are to be inserted in the far head (FH) area and the far tail (FT) area at a coding rate having even greater error correction ability than the 1/4-coding rate. Thereafter, the group formatter **514** may insert the coded enhanced data either in the far head (FH) and far tail (FT) areas or in a reserved area for future usage.

Apart from the enhanced data, the group formatter **513** may also insert supplemental information data such as signaling information indicating the overall transmission information

in the data group. Also, apart from the coded enhanced data outputted from the block processor **513**, and in relation with the data deinterleaving process in a later process, the group formatter **514** may also insert a MPEG header place holder, a non-systematic RS parity place holder, and a main data place holder in the data group. Herein, the main data group place holder is inserted because the enhanced data and the main data may be mixed in the head and tail areas depending upon the input of the data deinterleaver. For example, based upon the output of the data after being deinterleaved, the place holder for the MPEG header may be allocated to the front of each data packet. Additionally, the group formatter **514** may either insert known data generated according to a pre-defined rule, or insert a known data place holder for inserting known data in a later process. Furthermore, a place holder for the initialization of the trellis encoder module **527** is inserted in a corresponding area. For example, the initialization data place holder may be inserted at the beginning (or front) of the data place sequence.

The output of the group formatter **514** is inputted to the data deinterleaver **515**. And, the data deinterleaver **515** performs an inverse process of the data interleaver deinterleaving the data and place holder within the data group being outputted from the group formatter **514**. Thereafter, the data deinterleaver **515** outputs the deinterleaved data to the packet formatter **516**. Among the data deinterleaved and inputted, the packet formatter **516** removes the main data place holder and RS parity place holder that were allocated for the deinterleaving process from the inputted deinterleaved data. Thereafter, the remaining portion of the corresponding data is grouped, and 4 bytes of MPEG header are inserted therein. The 4-byte MPEG header is configured of a 1-byte MPEG synchronization byte added to the 3-byte MPEG header place holder.

When the group formatter **514** inserts the known data place holder, the packet formatter **516** may either insert actual known data in the known data place holder or output the known data place holder without any change or modification for a replacement insertion in a later process. Afterwards, the packet formatter **516** divides the data within the above-described packet-formatted data group into 188-byte unit enhanced data packets (i.e., MPEG TS packets), which are then provided to the packet multiplexer **521**. The packet multiplexer **521** multiplexes the 188-byte unit enhanced data packet and main data packet outputted from the packet formatter **516** according to a pre-defined multiplexing method. Subsequently, the multiplexed data packets are outputted to the data randomizer **522**. The multiplexing method may be modified or altered in accordance with diverse variables of the system design.

As an example of the multiplexing method of the packet multiplexer **521**, the enhanced data burst section and the main data section may be identified along a time axis (or a chronological axis) and may be alternately repeated. At this point, the enhanced data burst section may transmit at least one data group, and the main data section may transmit only the main data. The enhanced data burst section may also transmit the main data. If the enhanced data are outputted in a burst structure, as described above, the receiving system receiving only the enhanced data may turn the power on only during the burst section so as to receive the enhanced data, and may turn the power off during the main data section in which main data are transmitted, so as to prevent the main data from being received, thereby reducing the power consumption of the receiving system.

When the data being inputted correspond to the main data packet, the data randomizer **522** performs the same randomizing process of the conventional randomizer. More specifi-

cally, the MPEG synchronization byte included in the main data packet is discarded and a pseudo random byte generated from the remaining 187 bytes is used so as to randomize the data. Thereafter, the randomized data are outputted to the RS encoder/non-systematic RS encoder **523**. However, when the inputted data correspond to the enhanced data packet, the MPEG synchronization byte of the 4-byte MPEG header included in the enhanced data packet is discarded, and data randomizing is performed only on the remaining 3-byte MPEG header. Randomizing is not performed on the remaining portion of the enhanced data. Instead, the remaining portion of the enhanced data is outputted to the RS encoder/non-systematic RS encoder **523**. This is because the randomizing process has already been performed on the enhanced data by the enhanced data randomizer **511** in an earlier process. Herein, a data randomizing process may or may not be performed on the known data (or known data place holder) and the initialization data place holder included in the enhanced data packet.

The RS encoder/non-systematic RS encoder **523** RS-codes the data randomized by the data randomizer **522** or the data bypassing the data randomizer **522**. Then, the RS encoder/non-systematic RS encoder **523** adds a 20-byte RS parity to the coded data, thereby outputting the RS-parity-added data to the data interleaver **524**. At this point, if the inputted data correspond to the main data packet, the RS encoder/non-systematic RS encoder **523** performs a systematic RS-coding process identical to that of the conventional receiving system on the inputted data, thereby adding the 20-byte RS parity at the end of the 187-byte data. Alternatively, if the inputted data correspond to the enhanced data packet, the 20 bytes of RS parity gained by performing the non-systematic RS-coding are respectively inserted in the decided parity byte places within the enhanced data packet. Herein, the data interleaver **524** corresponds to a byte unit convolutional interleaver. The output of the data interleaver **524** is inputted to the parity byte replacer **525** and the non-systematic RS encoder **525**.

Meanwhile, a memory within the trellis encoding module **527**, which is positioned after the parity byte replacer **525**, should first be initialized in order to allow the output data of the trellis encoding module **527** so as to become the known data defined based upon an agreement between the receiving system and the transmitting system. More specifically, the memory of the trellis encoding module **527** should first be initialized before the known data sequence being inputted is trellis-encoded. At this point, the beginning of the known data sequence that is inputted corresponds to the initialization data place holder inserted by the group formatter **514** and not the actual known data. Therefore, a process of generating initialization data right before the trellis-encoding of the known data sequence being inputted and a process of replacing the initialization data place holder of the corresponding trellis encoding module memory with the newly generated initialization data are required.

A value of the trellis memory initialization data is decided based upon the memory status of the trellis encoding module **527**, thereby generating the trellis memory initialization data accordingly. Due to the influence of the replace initialization data, a process of recalculating the RS parity, thereby replacing the RS parity outputted from the trellis encoding module **527** with the newly calculated RS parity is required. Accordingly, the non-systematic RS encoder **526** receives the enhanced data packet including the initialization data place holder that is to be replaced with the initialization data from the data interleaver **524** and also receives the initialization data from the trellis encoding module **527**. Thereafter, among the received enhanced data packet, the initialization data

place holder is replaced with the initialization data. Subsequently, the RS parity data added to the enhanced data packet are removed. Then, a new non-systematic RS parity is calculated and outputted to the parity byte replacer **525**. Accordingly, the parity byte replacer **525** selects the output of the data interleaver **524** as the data within the enhanced data packet, and selects the output of the non-systematic RS encoder **526** as the RS parity. Thereafter, the parity byte replacer **525** outputs the selected data.

Meanwhile, if the main data packet is inputted, or if the enhanced data packet that does not include the initialization data place holder that is to be replaced, the parity byte replacer **525** selects the data and RS parity outputted from the data interleaver **524** and directly outputs the selected data to the trellis encoding module **527** without modification. The trellis encoding module **527** converts the byte-unit data to symbol-unit data and 12-way interleaves and trellis-encodes the converted data, which are then outputted to the frame multiplexer **528**. The frame multiplexer **528** inserts field synchronization and segment synchronization signals in the output of the trellis encoding module **527** and then outputs the processed data to the transmitting unit **530**. Herein, the transmitting unit **530** includes a pilot inserter **531**, a modulator **532**, and a radio frequency (RF) up-converter **533**. The operation of the transmitting unit **530** is identical to the conventional transmitters. Therefore, a detailed description of the same will be omitted for simplicity.

FIG. 9 illustrates a block diagram of a demodulating unit included in the receiving system according to another embodiment of the present invention. Herein, the demodulating unit may effectively process signals transmitted from the transmitting system shown in FIG. 8. Referring to FIG. 9, the demodulating unit includes a demodulator **601**, a channel equalizer **602**, a known sequence detector **603**, a block decoder **604**, an enhanced data deformatter **605**, a RS frame decoder **606**, an enhanced data derandomizer **607**, a data deinterleaver **608**, a RS decoder **609**, and a main data derandomizer **910**. For simplicity, the demodulator **601**, the channel equalizer **602**, the known sequence detector **603**, the block decoder **604**, the enhanced data deformatter **605**, the RS frame decoder **606**, and the enhanced data derandomizer **607** will be referred to as an enhanced data processor. And, the data deinterleaver **608**, the RS decoder **609**, and the main data derandomizer **910** will be referred to as a main data processor.

More specifically, the enhanced data including known data and the main data are received through the tuner and inputted to the demodulator **601** and the known sequence detector **603**. The demodulator **601** performs automatic gain control, carrier wave recovery, and timing recovery on the data that are being inputted, thereby creating baseband data, which are then outputted to the equalizer **602** and the known sequence detector **603**. The equalizer **602** compensates the distortion within the channel included in the demodulated data. Then, the equalizer **602** outputs the compensated data to the block decoder **604**.

At this point, the known sequence detector **603** detects the known data place inserted by the transmitting system to the input/output data of the demodulator **601** (i.e., data prior to demodulation or data after demodulation). Then, along with the position information, the known sequence detector **603** outputs the symbol sequence of the known data generated from the corresponding position to the demodulator **601** and the equalizer **602**. Additionally, the known sequence detector **603** outputs information enabling the block decoder **604** to identify the enhanced data being additionally encoded by the transmitting system and the main data that are not additionally encoded to the block decoder **604**. Furthermore, although

the connection is not shown in FIG. 9, the information detected by the known sequence detector **603** may be used in the overall receiving system and may also be used in the enhanced data formatter **605** and the RS frame decoder **606**.

By using the known data symbol sequence when performing the timing recovery or carrier wave recovery, the demodulating performance of the demodulator **601** may be enhanced. Similarly, by using the known data, the channel equalizing performance of the channel equalizer **602** may be enhanced. Furthermore, by feeding-back the demodulation result of the block demodulator **604**, the channel equalizing performance may also be enhanced. Herein, the channel equalizer **602** may perform channel equalization through various methods. In the present invention, a method of estimating a channel impulse response (CIR) for performing the channel equalization process will be given as an example of the present invention. More specifically, in the present invention, the channel impulse response (CIR) is differently estimated and applied in accordance with each hierarchical area within the data group that are transmitted from the transmitting system. Furthermore, by using the known data having the position (or place) and contents pre-known according to an agreement between the transmitting system and the receiving system, so as to estimate the CIR, the channel equalization process may be processed with more stability.

In the present invention, one data group that is inputted for channel equalization is divided into three hierarchical areas: a head area, a body area, and a tail area. Then, each of the areas is divided into lower hierarchical areas. More specifically, the head area may be divided into a far head (FH) area, a middle head (MH) area, and a near head (NH) area. And, the tail area may be divided into a far tail (FT) area and a near tail (NT) area. Furthermore, based upon a long known data sequence, the body area may be divided into 4 lower hierarchical areas: a first lower body (H1) area, a second lower body (B2) area, a third lower body (B3) area, and a fourth lower body (B4) area. In performing channel equalization on the data within the data group by using the CIR estimated from the field synchronization signal and the known data sequence, and in accordance with the characteristic of each area, either one of the estimated CIRs may be directly used without modification, or a CIR created by interpolating or extrapolating a plurality of CIRs may be used.

Meanwhile, if the data being channel equalized and then inputted to the block decoder **604** correspond to the enhanced data on which additional encoding and trellis encoding are both performed by the transmitting system, trellis-decoding and additional decoding processes are performed as inverse processes of the transmitting system. Alternatively, if the data being channel equalized and then inputted to the block decoder **604** correspond to the main data on which additional encoding is not performed and only trellis-encoding is performed by the transmitting system, only the trellis-decoding process is performed. The data group decoded by the block decoder **604** is inputted to the enhanced data deformatter **605**, and the main data packet is inputted to the data deinterleaver **608**.

More specifically, if the inputted data correspond to the main data, the block decoder **604** performs Viterbi decoding on the inputted data, so as to either output a hard decision value or hard-decide a soft decision value and output the hard-decided result. On the other hand, if the inputted correspond to the enhanced data, the block decoder **604** outputs either a hard decision value or a soft decision value on the inputted enhanced data. In other words, if the data inputted to the block decoder **604** correspond to the enhanced data, the block decoder **604** performs a decoding process on the data

encoded by the block processor and the trellis encoder of the transmitting system. At this point, the output of the RS frame encoder included in the pre-processor of the transmitting system becomes an external code, and the output of the block processor and the trellis encoder becomes an internal code. In order to show maximum performance of the external code when decoding such connection codes, the decoder of the internal code should output a soft decision value. Therefore, the block decoder **604** may output a hard decision value on the enhanced data. However, when required, it is more preferable that the block decoder **604** outputs a soft decision value.

The present invention may also be used for configuring a reliability map using the soft decision value. The reliability map determines and indicates whether a byte corresponding to a group of 8 bits decided by the code of the soft decision value is reliable. For example, when an absolute value of the soft decision value exceeds a pre-determined threshold value, the value of the bit corresponding to the soft decision value code is determined to be reliable. However, if the absolute value does not exceed the pre-determined threshold value, then the value of the corresponding bit is determined to be not reliable. Further, if at least one bit among the group of 8 bits, which are determined based upon the soft decision value, is determined to be not reliable, then the reliability map indicates that the entire byte is not reliable. Herein, the process of determining the reliability by 1-bit units is merely exemplary. The corresponding byte may also be indicated to be not reliable if a plurality of bits (e.g., 4 bits) is determined to be not reliable.

Conversely, when all of the bits are determined to be reliable within one byte (i.e., when the absolute value of the soft value of all bits exceeds the pre-determined threshold value), then the reliability map determines and indicates that the corresponding data byte is reliable. Similarly, when more than 4 bits are determined to be reliable within one data byte, then the reliability map determines and indicates that the corresponding data byte is reliable. The estimated numbers are merely exemplary and do not limit the scope and spirit of the present invention. Herein, the reliability map may be used when performing error correction decoding processes.

Meanwhile, the data deinterleaver **608**, the RS decoder **609**, and the main data derandomizer **910** are blocks required for receiving the main data. These blocks may not be required in a receiving system structure that receives only the enhanced data. The data deinterleaver **608** performs an inverse process of the data interleaver of the transmitting system. More specifically, the data deinterleaver **608** deinterleaves the main data being outputted from the block decoder **604** and outputs the deinterleaved data to the RS decoder **609**. The RS decoder **609** performs systematic RS decoding on the deinterleaved data and outputs the systematically decoded data to the main data derandomizer **910**. The main data derandomizer **910** receives the data outputted from the RS decoder **609** so as to generate the same pseudo random byte as that of the randomizer in the transmitting system. The main data derandomizer **910** then performs a bitwise exclusive OR (XOR) operation on the generated pseudo random data byte, thereby inserting the MPEG synchronization bytes to the beginning of each packet so as to output the data in 188-byte main data packet units.

Herein, the format of the data being outputted to the enhanced data deformatter **605** from the block decoder **604** is a data group format. At this point, the enhanced data deformatter **605** already knows the structure of the input data. Therefore, the enhanced data deformatter **605** identifies the system information including signaling information and the enhanced data from the data group. Thereafter, the identified

signaling information is transmitted to where the system information is required, and the enhanced data are outputted to the RS frame decoder **606**. The enhanced data deformatter **605** removes the known data, trellis initialization data, and MPEG header that were included in the main data and the data group and also removes the RS parity that was added by the RS encoder/non-systematic RS encoder of the transmitting system. Thereafter, the processed data are outputted to the RS frame decoder **606**.

More specifically, the RS frame decoder **606** receives the RS-coded and CRC-coded enhanced data from the enhanced data deformatter **605** so as to configure the RS frame. The RS frame decoder **606** performs an inverse process of the RS frame encoder included in the transmitting system, thereby correcting the errors within the RS frame. Then, the 1-byte MPEG synchronization byte, which was removed during the RS frame coding process, is added to the error corrected enhanced data packet. Subsequently, the processed data are outputted to the enhanced data derandomizer **607**. Herein, the enhanced data derandomizer **607** performs a derandomizing process, which corresponds to an inverse process of the enhanced data randomizer included in the transmitting system, on the received enhanced data. Then, by outputting the processed data, the enhanced data transmitted from the transmitting system can be obtained.

According to an embodiment of the present invention, the RS frame decoder **606** may also be configured as follows. The RS frame decoder **606** may perform a CRC syndrome check on the RS frame, thereby verifying whether or not an error has occurred in each row. Subsequently, the CRC checksum is removed and the presence of an error is indicated on a CRC error flag corresponding to each row. Then, a RS decoding process is performed on the RS frame having the CRC checksum removed in a column direction. At this point, depending upon the number of CRC error flags, a RS erasure decoding process may be performed. More specifically, by checking the CRC error flags corresponding to each row within the RS frame, the number of CRC error flags may be determined whether it is greater or smaller than the maximum number of errors, when RS decoding the number of rows with errors (or erroneous rows) in the column direction. Herein, the maximum number of errors corresponds to the number of parity bytes inserted during the RS decoding process. As an example of the present invention, it is assumed that 48 parity bytes are added to each column.

If the number of rows with CRC errors is equal to or smaller than the maximum number of errors (e.g., 48), which may be corrected by the RS erasure decoding process, the RS erasure decoding process is performed on the RS frame in the column direction. Thereafter, the 48 bytes of parity data that were added at the end of each column are removed. However, if the number of rows with CRC errors is greater than the maximum number of errors (e.g., 48), which may be corrected by the RS erasure decoding process, the RS erasure decoding process cannot be performed. In this case, the error may be corrected by performing a general RS decoding process.

As another embodiment of the present invention, the error correction ability may be enhanced by using the reliability map created when configuring the RS frame from the soft decision value. More specifically, the RS frame decoder **606** compares the absolute value of the soft decision value obtained from the block decoder **604** to the pre-determined threshold value so as to determine the reliability of the bit values that are decided by the code of the corresponding soft decision value. Then, 8 bits are grouped to configure a byte. Then, the reliability information of the corresponding byte is indicated on the reliability map. Therefore, even if a specific

row is determined to have CRC errors as a result of the CRC syndrome checking process of the corresponding row, it is not assumed that all of the data bytes included in the corresponding row have error. Instead, only the data bytes that are determined to be not reliable, after referring to the reliability information on the reliability map, are set to have errors. In other words, regardless of the presence of CRC errors in the corresponding row, only the data bytes that are determined to be not reliable (or unreliable) by the reliability map are set as erasure points.

Thereafter, if the number of erasure points for each column is equal to or smaller than the maximum number of errors (e.g., 48), the RS erasure decoding process is performed on the corresponding the column. Conversely, if the number of erasure points is greater than the maximum number of errors (e.g., 48), which may be corrected by the RS erasure decoding process, a general decoding process is performed on the corresponding column. In other words, if the number of rows having CRC errors is greater than the maximum number of errors (e.g., 48), which may be corrected by the RS erasure decoding process, either a RS erasure decoding process or a general RS decoding process is performed on a particular column in accordance with the number of erasure point within the corresponding column, wherein the number is decided based upon the reliability information on the reliability map. When the above-described process is performed, the error correction decoding process is performed in the direction of all of the columns included in the RS frame. Thereafter, the 48 bytes of parity data added to the end of each column are removed.

FIG. 10 illustrates a block diagram showing the structure of a digital broadcast receiving system according to an embodiment of the present invention. Referring to FIG. 10, the digital broadcast receiving system includes a tuner 701, a demodulating unit 702, a demultiplexer 703, an audio decoder 704, a video decoder 705, a native TV application manager 706, a channel manager 707, a channel map 708, a first memory 709, a data decoder 710, a second memory 711, a system manager 712, a data broadcasting application manager 713, a storage controller 714, and a third memory 715. Herein, the third memory 715 is a mass storage device, such as a hard disk drive (HDD) or a memory chip. The tuner 701 tunes a frequency of a specific channel through any one of an antenna, cable, and satellite. Then, the tuner 701 down-converts the tuned frequency to an intermediate frequency (IF), which is then outputted to the demodulating unit 702. At this point, the tuner 701 is controlled by the channel manager 707. Additionally, the result and strength of the broadcast signal of the tuned channel are also reported to the channel manager 707. The data that are being received by the frequency of the tuned specific channel include main data, enhanced data, and table data for decoding the main data and enhanced data.

In the embodiment of the present invention, examples of the enhanced data may include data provided for data service, such as Java application data, HTML application data, XML data, and so on. The data provided for such data services may correspond either to a Java class file for the Java application, or to a directory file designating positions (or locations) of such files. Furthermore, such data may also correspond to an audio file and/or a video file used in each application. The data services may include weather forecast services, traffic information services, stock information services, services providing information quiz programs providing audience participation services, real time poll, user interactive education programs, gaming services, services providing information on soap opera (or TV series) synopsis, characters, original sound track, filing sites, services providing information on

past sports matches, profiles and accomplishments of sports players, product information and product ordering services, services providing information on broadcast programs by media type, airing time, subject, and so on. The types of data services described above are only exemplary and are not limited only to the examples given herein. Furthermore, depending upon the embodiment of the present invention, the enhanced data may correspond to meta data. For example, the meta data use the XML application so as to be transmitted through a DSM-CC protocol.

The demodulating unit 702 performs VSB-demodulation and channel equalization on the signal being outputted from the tuner 701, thereby identifying the main data and the enhanced data. Thereafter, the identified main data and enhanced data are outputted in TS packet units. Examples of the demodulating unit 702 are shown in FIG. 7 and FIG. 9. The demodulating unit shown in FIG. 7 and FIG. 9 is merely exemplary and the scope of the present invention is not limited to the examples set forth herein. In the embodiment given as an example of the present invention, only the enhanced data packet outputted from the demodulating unit 702 is inputted to the demultiplexer 703. In this case, the main data packet is inputted to another demultiplexer (not shown) that processes main data packets. Herein, the storage controller 714 is also connected to the other demultiplexer in order to store the main data after processing the main data packets. The demultiplexer of the present invention may also be designed to process both enhanced data packets and main data packets in a single demultiplexer.

The storage controller 714 is interfaced with the demultiplexer so as to control instant recording, reserved (or pre-programmed) recording, time shift, and so on of the enhanced data and/or main data. For example, when one of instant recording, reserved (or pre-programmed) recording, and time shift is set and programmed in the receiving system (or receiver) shown in FIG. 10, the corresponding enhanced data and/or main data that are inputted to the demultiplexer are stored in the third memory 715 in accordance with the control of the storage controller 714. The third memory 715 may be described as a temporary storage area and/or a permanent storage area. Herein, the temporary storage area is used for the time shifting function, and the permanent storage area is used for a permanent storage of data according to the user's choice (or decision).

When the data stored in the third memory 715 need to be reproduced (or played), the storage controller 714 reads the corresponding data stored in the third memory 715 and outputs the read data to the corresponding demultiplexer (e.g., the enhanced data are outputted to the demultiplexer 703 shown in FIG. 10). At this point, according to the embodiment of the present invention, since the storage capacity of the third memory 715 is limited, the compression encoded enhanced data and/or main data that are being inputted are directly stored in the third memory 715 without any modification for the efficiency of the storage capacity. In this case, depending upon the reproduction (or reading) command, the data read from the third memory 715 pass through the demultiplexer so as to be inputted to the corresponding decoder, thereby being restored to the initial state.

The storage controller 714 may control the reproduction (or play), fast-forward, rewind, slow motion, instant replay functions of the data that are already stored in the third memory 715 or presently being buffered. Herein, the instant replay function corresponds to repeatedly viewing scenes that the viewer (or user) wishes to view once again. The instant replay function may be performed on stored data and also on data that are currently being received in real time by associ-

ating the instant replay function with the time shift function. If the data being inputted correspond to the analog format, for example, if the transmission mode is NTSC, PAL, and so on, the storage controller 714 compression encodes the inputted data and stored the compression-encoded data to the third memory 715. In order to do so, the storage controller 714 may include an encoder, wherein the encoder may be embodied as one of software, middleware, and hardware. Herein, an MPEG encoder may be used as the encoder according to an embodiment of the present invention. The encoder may also be provided outside of the storage controller 714.

Meanwhile, in order to prevent illegal duplication (or copies) of the input data being stored in the third memory 715, the storage controller 714 scrambles the input data and stores the scrambled data in the third memory 715. Accordingly, the storage controller 714 may include a scramble algorithm for scrambling the data stored in the third memory 715 and a descramble algorithm for descrambling the data read from the third memory 715. Herein, the definition of scramble includes encryption, and the definition of descramble includes decryption. The scramble method may include using an arbitrary key (e.g., control word) to modify a desired set of data, and also a method of mixing signals.

Meanwhile, the demultiplexer 703 receives the real-time data outputted from the demodulating unit 702 or the data read from the third memory 715 and demultiplexes the received data. In the example given in the present invention, the demultiplexer 703 performs demultiplexing on the enhanced data packet. Therefore, in the present invention, the receiving and processing of the enhanced data will be described in detail. It should also be noted that a detailed description of the processing of the main data will be omitted for simplicity starting from the description of the demultiplexer 703 and the subsequent elements.

The demultiplexer 703 demultiplexes enhanced data and program specific information/program and system information protocol (PSI/PSIP) tables from the enhanced data packet inputted in accordance with the control of the data decoder 710. Thereafter, the demultiplexed enhanced data and PSI/PSIP tables are outputted to the data decoder 710 in a section format. In order to extract the enhanced data from the channel through which enhanced data are transmitted and to decode the extracted enhanced data, system information is required. Such system information may also be referred to as service information. The system information may include channel information, event information, etc. In the embodiment of the present invention, the PSI/PSIP tables are applied as the system information. However, the present invention is not limited to the example set forth herein. More specifically, regardless of the name, any protocol transmitting system information in a table format may be applied in the present invention.

The PSI table is an MPEG-2 system standard defined for identifying the channels and the programs. The PSIP table is an advanced television systems committee (ATSC) standard that can identify the channels and the programs. The PSI table may include a program association table (PAT), a conditional access table (CAT), a program map table (PMT), and a network information table (NIT). Herein, the PAT corresponds to special information that is transmitted by a data packet having a PID of '0'. The PAT transmits PID information of the PMT and PID information of the NIT corresponding to each program. The CAT transmits information on a paid broadcast system used by the transmitting system. The PMT transmits PID information of a transport stream (TS) packet, in which program identification numbers and individual bit sequences of video and audio data configuring the corresponding pro-

gram are transmitted, and the PID information, in which PCR is transmitted. The NIT transmits information of the actual transmission network.

The PSIP table may include a virtual channel table (VCT), a system time table (STT), a rating region table (RRT), an extended text table (ETT), a direct channel change table (DCCT), an event information table (EIT), and a master guide table (MGT). The VCT transmits information on virtual channels, such as channel information for selecting channels and information such as packet identification (PID) numbers for receiving the audio and/or video data. More specifically, when the VCT is parsed, the PID of the audio/video data of the broadcast program may be known. Herein, the corresponding audio/video data are transmitted within the channel along with the channel name and the channel number. The STT transmits information on the current data and timing information. The RRT transmits information on region and consultation organs for program ratings. The ETT transmits additional description of a specific channel and broadcast program. The EIT transmits information on virtual channel events (e.g., program title, program start time, etc.). The DCCT/DCCSCT transmits information associated with automatic (or direct) channel change. And, the MGT transmits the versions and PID information of the above-mentioned tables included in the PSIP.

Each of the above-described tables included in the PSI/PSIP is configured of a basic unit referred to as a "section" and a combination of one or more sections forms a table. For example, the VCT may be divided into 256 sections. Herein, one section may include a plurality of virtual channel information. However, a single set of virtual channel information is not divided into two or more sections. At this point, the receiving system may parse and decode the data for the data service that are transmitting by using only the tables included in the PSI, or only the tables included in the PSIP, or a combination of tables included in both the PSI and the PSIP. In order to parse and decode the data for the data service, at least one of the PAT and PMT included in the PSI, and the VCT included in the PSIP is required. For example, the PAT may include the system information for transmitting the data corresponding to the data service, and the PID of the PMT corresponding to the data service data (or program number). The PMT may include the PID of the TS packet used for transmitting the data service data. The VCT may include information on the virtual channel for transmitting the data service data, and the PID of the TS packet for transmitting the data service data.

Meanwhile, depending upon the embodiment of the present invention, a DVB-SI may be applied instead of the PSIP. The DVB-SI may include a network information table (NIT), a service description table (SDT), an event information table (EIT), and a time and data table (TDT). The DVB-SI may be used in combination with the above-described PSI. Herein, the NIT divides the services corresponding to particular network providers by specific groups. The NIT includes all tuning information that are used during the IRD set-up. The NIT may be used for informing or notifying any change in the tuning information. The SDT includes the service name and different parameters associated with each service corresponding to a particular MPEG multiplex. The EIT is used for transmitting information associated with all events occurring in the MPEG multiplex. The EIT includes information on the current transmission and also includes information selectively containing different transmission streams that may be received by the IRD. And, the TDT is used for updating the clock included in the IRD.

Furthermore, three selective SI tables (i.e., a bouquet associate table (BAT), a running status table (RST), and a stuffing table (ST)) may also be included. More specifically, the bouquet associate table (BAT) provides a service grouping method enabling the IRD to provide services to the viewers. Each specific service may belong to at least one 'bouquet' unit. A running status table (RST) section is used for promptly and instantly updating at least one event execution status. The execution status section is transmitted only once at the changing point of the event status. Other SI tables are generally transmitted several times. The stuffing table (ST) may be used for replacing or discarding a subsidiary table or the entire SI tables.

In the present invention, the enhanced data included in the payload within the TS packet consist of a digital storage media-command and control (DSM-CC) section format. However, the TS packet including the data service data may correspond either to a packetized elementary stream (PES) type or to a section type. More specifically, either the PES type data service data configure the TS packet, or the section type data service data configure the TS packet. The TS packet configured of the section type data will be given as the example of the present invention. At this point, the data service data are included in the digital storage media-command and control (DSM-CC) section. Herein, the DSM-CC section is then configured of a 188-byte unit TS packet.

Furthermore, the packet identification of the TS packet configuring the DSM-CC section is included in a data service table (DST). When transmitting the DST, '0x95' is assigned as the value of a stream_type field included in the service location descriptor of the PMT or the VCT. More specifically, when the PMT or VCT stream_type field value is '0x95', the receiving system may acknowledge that data broadcasting including enhanced data (i.e., the enhanced data) is being received. At this point, the enhanced data may be transmitted by a data carousel method. The data carousel method corresponds to repeatedly transmitting identical data on a regular basis.

At this point, according to the control of the data decoder 710, the demultiplexer 703 performs section filtering, thereby discarding repetitive sections and outputting only the non-repetitive sections to the data decoder 710. The demultiplexer 703 may also output only the sections configuring desired tables (e.g., VCT) to the data decoder 710 by section filtering. Herein, the VCT may include a specific descriptor for the enhanced data. However, the present invention does not exclude the possibilities of the enhanced data being included in other tables, such as the PMT. The section filtering method may include a method of verifying the PID of a table defined by the MGT, such as the VCT, prior to performing the section filtering process. Alternatively, the section filtering method may also include a method of directly performing the section filtering process without verifying the MGT, when the VCT includes a fixed PID (i.e., a base PID). At this point, the demultiplexer 703 performs the section filtering process by referring to a table_id field, a version_number field, a section_number field, etc.

As described above, the method of defining the PID of the VCT broadly includes two different methods. Herein, the PID of the VCT is a packet identifier required for identifying the VCT from other tables. The first method consists of setting the PID of the VCT so that it is dependent to the MGT. In this case, the receiving system cannot directly verify the VCT among the many PSI and/or PSIP tables. Instead, the receiving system must check the PID defined in the MGT in order to read the VCT. Herein, the MGT defines the PID, size, version number, and so on, of diverse tables. The second method

consists of setting the PID of the VCT so that the PID is given a base PID value (or a fixed PID value), thereby being independent from the MGT. In this case, unlike in the first method, the VCT according to the present invention may be identified without having to verify every single PID included in the MGT. Evidently, an agreement on the base PID must be previously made between the transmitting system and the receiving system.

Meanwhile, in the embodiment of the present invention, the demultiplexer 703 may output only an application information table (AIT) to the data decoder 710 by section filtering. The AIT includes information on an application being operated in the receiving system for the data service. The AIT may also be referred to as an XAIT, and an AMT. Therefore, any table including application information may correspond to the following description. When the AIT is transmitted, a value of '0x05' may be assigned to a stream_type field of the PMT. The AIT may include application information, such as application name, application version, application priority, application ID, application status (i.e., auto-start, user-specific settings, kill, etc.), application type (i.e., Java or HTML), position (or location) of stream including application class and data files, application platform directory, and location of application icon.

In the method for detecting application information for the data service by using the AIT, component_tag, original_network_id, transport_stream_id, and service_id fields may be used for detecting the application information. The component_tag field designates an elementary stream carrying a DSI of a corresponding object carousel. The original_network_id field indicates a DVB-SI original_network_id of the TS providing transport connection. The transport_stream_id field indicates the MPEG TS of the TS providing transport connection, and the service_id field indicates the DVB-SI of the service providing transport connection. Information on a specific channel may be obtained by using the original_network_id field, the transport_stream_id field, and the service_id field. The data service data, such as the application data, detected by using the above-described method may be stored in the second memory 711 by the data decoder 710.

The data decoder 710 parses the DSM-CC section configuring the demultiplexed enhanced data. Then, the enhanced data corresponding to the parsed result are stored as a database in the second memory 711. The data decoder 710 groups a plurality of sections having the same table identification (table_id) so as to configure a table, which is then parsed. Thereafter, the parsed result is stored as a database in the second memory 711. At this point, by parsing data and/or sections, the data decoder 710 reads all of the remaining actual section data that are not section-filtered by the demultiplexer 703. Then, the data decoder 710 stores the read data to the second memory 711. The second memory 711 corresponds to a table and data carousel database storing system information parsed from tables and enhanced data parsed from the DSM-CC section. Herein, a table_id field, a section_number field, and a last_section_number field included in the table may be used to indicate whether the corresponding table is configured of a single section or a plurality of sections. For example, TS packets having the PID of the VCT are grouped to form a section, and sections having table identifiers allocated to the VCT are grouped to form the VCT.

When the VCT is parsed, information on the virtual channel to which enhanced data are transmitted may be obtained. The obtained application identification information, service component identification information, and service information corresponding to the data service may either be stored in the second memory 711 or be outputted to the data broadcast-

ing application manager 713. In addition, reference may be made to the application identification information, service component identification information, and service information in order to decode the data service data. Alternatively, such information may also prepare the operation of the application program for the data service. Furthermore, the data decoder 710 controls the demultiplexing of the system information table, which corresponds to the information table associated with the channel and events. Thereafter, an A.V PID list may be transmitted to the channel manager 707.

The channel manager 707 may refer to the channel map 70e in order to transmit a request for receiving system-related information data to the data decoder 710, thereby receiving the corresponding result. In addition, the channel manager 707 may also control the channel tuning of the tuner 701. Furthermore, the channel manager 707 may directly control the demultiplexer 703, so as to set up the A/V PID, thereby controlling the audio decoder 704 and the video decoder 705. The audio decoder 704 and the video decoder 705 may respectively decode and output the audio data and video data demultiplexed from the main data packet. Alternatively, the audio decoder 704 and the video decoder 705 may respectively decode and output the audio data and video data demultiplexed from the enhanced data packet. Meanwhile, when the enhanced data include data service data, and also audio data and video data, it is apparent that the audio data and video data demultiplexed by the demultiplexer 703 are respectively decoded by the audio decoder 704 and the video decoder 705. For example, an audio-coding (AC)-3 decoding algorithm may be applied to the audio decoder 704, and a MPEG-2 decoding algorithm may be applied to the video decoder 705.

Meanwhile, the native TV application manager 706 operates a native application program stored in the first memory 709, thereby performing general functions such as channel change. The native application program refers to software stored in the receiving system upon shipping of the product. More specifically, when a user request (or command) is transmitted to the receiving system through a user interface (UI), the native TV application manager 706 displays the user request on a screen through a graphic user interface (GUI), thereby responding to the user's request. The user interface receives the user request through an input device, such as a remote controller, a key pad, a jog controller, an a touch-screen provided on the screen, and then outputs the received user request to the native TV application manager 706 and the data broadcasting application manager 713. Furthermore, the native TV application manager 706 controls the channel manager 707, thereby controlling channel-associated, such as the management of the channel map 708, and controlling the data decoder 710. The native TV application manager 706 also controls the GUI of the overall receiving system, thereby storing the user request and status of the receiving system in the first memory 709 and restoring the stored information.

The channel manager 707 controls the tuner 701 and the data decoder 710, so as to managing the channel map 708 so that it can respond to the channel request made by the user. More specifically, channel manager 707 sends a request to the data decoder 710 so that the tables associated with the channels that are to be tuned are parsed. The results of the parsed tables are reported to the channel manager 707 by the data decoder 710. Thereafter, based on the parsed results, the channel manager 707 updates the channel map 708 and sets up a PID in the demultiplexer 703 for demultiplexing the tables associated with the data service data from the enhanced data.

The system manager 712 controls the booting of the receiving system by turning the power on or off. Then, the system

manager 712 stores ROM images (including downloaded software images) in the first memory 709. More specifically, the first memory 709 stores management programs such as operating system (OS) programs required for managing the receiving system and also application program executing data service functions. The application program is a program processing the data service data stored in the second memory 711 so as to provide the user with the data service. If the data service data are stored in the second memory 711, the corresponding data service data are processed by the above-described application program or by other application programs, thereby being provided to the user. The management program and application program stored in the first memory 709 may be updated or corrected to a newly downloaded program. Furthermore, the storage of the stored management program and application program is maintained without being deleted even if the power of the system is shut down. Therefore, when the power is supplied the programs may be executed without having to be newly downloaded once again.

The application program for providing data service according to the present invention may either be initially stored in the first memory 709 upon the shipping of the receiving system, or be stored in the first 709 after being downloaded. The application program for the data service (i.e., the data service providing application program) stored in the first memory 709 may also be deleted, updated, and corrected. Furthermore, the data service providing application program may be downloaded and executed along with the data service data each time the data service data are being received.

When a data service request is transmitted through the user interface, the data broadcasting application manager 713 operates the corresponding application program stored in the first memory 709 so as to process the requested data, thereby providing the user with the requested data service. And, in order to provide such data service, the data broadcasting application manager 713 supports the graphic user interface (GUI). Herein, the data service may be provided in the form of text (or short message service (SMS)), voice message, still image, and moving image. The data broadcasting application manager 713 may be provided with a platform for executing the application program stored in the first memory 709. The platform may be, for example, a Java virtual machine for executing the Java program. Hereinafter, an example of the data broadcasting application manager 713 executing the data service providing application program stored in the first memory 709, so as to process the data service data stored in the second memory 711, thereby providing the user with the corresponding data service will now be described in detail.

Assuming that the data service corresponds to a traffic information service, the data service according to the present invention is provided to the user of a receiving system that is not equipped with an electronic map and/or a GPS system in the form of at least one of a text (or short message service (SMS)), a voice message, a graphic message, a still image, and a moving image. In this case, is a GPS module is mounted on the receiving system shown in FIG. 10, the GPS module receives satellite signals transmitted from a plurality of low earth orbit satellites and extracts the current position (or location) information (e.g., longitude, latitude, altitude), thereby outputting the extracted information to the data broadcasting application manager 713.

At this point, it is assumed that the electronic map including information on each link and nod and other diverse graphic information are stored in one of the second memory 711, the first memory 709, and another memory that is not shown. More specifically, according to the request made by the data broadcasting application manager 713, the data ser-

vice data stored in the second memory 711 are read and inputted to the data broadcasting application manager 713. The data broadcasting application manager 713 translates (or deciphers) the data service data read from the second memory 711, thereby extracting the necessary information according to the contents of the message and/or a control signal.

FIG. 11 illustrates a block diagram showing the structure of a digital broadcast (or television) receiving system according to another embodiment of the present invention. Referring to FIG. 11, the digital broadcast receiving system includes a tuner 801, a demodulating unit 802, a demultiplexer 803, a first descrambler 804, an audio decoder 805, a video decoder 806, a second descrambler 807, an authentication unit 808, a native TV application manager 809, a channel manager 810, a channel map 811, a first memory 812, a data decoder 813, a second memory 814, a system manager 815, a data broadcasting application manager 816, a storage controller 817, a third memory 818, and a telecommunication module 819. Herein, the third memory 818 is a mass storage device, such as a hard disk drive (HDD) or a memory chip. Also, during the description of the digital broadcast (or television or DTV) receiving system shown in FIG. 11, the components that are identical to those of the digital broadcast receiving system of FIG. 10 will be omitted for simplicity.

As described above, in order to provide services for preventing illegal duplication (or copies) or illegal viewing of the enhanced data and/or main data that are transmitted by using a broadcast network, and to provide paid broadcast services, the transmitting system may generally scramble and transmit the broadcast contents. Therefore, the receiving system needs to descramble the scrambled broadcast contents in order to provide the user with the proper broadcast contents. Furthermore, the receiving system may generally be processed with an authentication process with an authentication means before the descrambling process. Hereinafter, the receiving system including an authentication means and a descrambling means according to an embodiment of the present invention will now be described in detail.

According to the present invention, the receiving system may be provided with a descrambling means receiving scrambled broadcasting contents and an authentication means authenticating (or verifying) whether the receiving system is entitled to receive the descrambled contents. Hereinafter, the descrambling means will be referred to as first and second descramblers 804 and 807, and the authentication means will be referred to as an authentication unit 808. Such naming of the corresponding components is merely exemplary and is not limited to the terms suggested in the description of the present invention. For example, the units may also be referred to as a decryptor. Although FIG. 11 illustrates an example of the descramblers 804 and 807 and the authentication unit 808 being provided inside the receiving system, each of the descramblers 804 and 807 and the authentication unit 808 may also be separately provided in an internal or external module. Herein, the module may include a slot type, such as a SD or CF memory, a memory stick type, a USB type, and so on, and may be detachably fixed to the receiving system.

As described above, when the authentication process is performed successfully by the authentication unit 808, the scrambled broadcasting contents are descrambled by the descramblers 804 and 807, thereby being provided to the user. At this point, a variety of the authentication method and descrambling method may be used herein. However, an agreement on each corresponding method should be made between the receiving system and the transmitting system. Hereinafter, the authentication and descrambling methods

will now be described, and the description of identical components or process steps will be omitted for simplicity.

The receiving system including the authentication unit 808 and the descramblers 804 and 807 will now be described in detail. The receiving system receives the scrambled broadcasting contents through the tuner 801 and the demodulating unit 802. Then, the system manager 815 decides whether the received broadcasting contents have been scrambled. Herein, the demodulating unit 802 may be included as a demodulating means according to embodiments of the present invention as described in FIG. 7 and FIG. 9. However, the present invention is not limited to the examples given in the description set forth herein. If the system manager 815 decides that the received broadcasting contents have been scrambled, then the system manager 815 controls the system to operate the authentication unit 908. As described above, the authentication unit 808 performs an authentication process in order to decide whether the receiving system according to the present invention corresponds to a legitimate host entitled to receive the paid broadcasting service. Herein, the authentication process may vary in accordance with the authentication methods.

For example, the authentication unit 808 may perform the authentication process by comparing an IP address of an IP datagram within the received broadcasting contents with a specific address of a corresponding host. At this point, the specific address of the corresponding receiving system (or host) may be a MAC address. More specifically, the authentication unit 808 may extract the IP address from the decapsulated IP datagram, thereby obtaining the receiving system information that is mapped with the IP address. At this point, the receiving system should be provided, in advance, with information (e.g., a table format) that can map the IP address and the receiving system information. Accordingly, the authentication unit 808 performs the authentication process by determining the conformity between the address of the corresponding receiving system and the system information of the receiving system that is mapped with the IP address. In other words, if the authentication unit 808 determines that the two types of information conform to one another, then the authentication unit 808 determines that the receiving system is entitled to receive the corresponding broadcasting contents.

In another example, standardized identification information is defined in advance by the receiving system and the transmitting system. Then, the identification information of the receiving system requesting the paid broadcasting service is transmitted by the transmitting system. Thereafter, the receiving system determines whether the received identification information conforms with its own unique identification number, so as to perform the authentication process. More specifically, the transmitting system creates a database for storing the identification information (or number) of the receiving system requesting the paid broadcasting service. Then, if the corresponding broadcasting contents are scrambled, the transmitting system includes the identification information in the EMM, which is then transmitted to the receiving system.

If the corresponding broadcasting contents are scrambled, messages (e.g., entitlement control message (ECM), entitlement management message (EMM)), such as the CAS information, mode information, message position information, that are applied to the scrambling of the broadcasting contents are transmitted through a corresponding data header or another data packet. The ECM may include a control word (CW) used for scrambling the broadcasting contents. At this point, the control word may be encoded with an authentication key. The EMM may include an authentication key and entitlement information of the corresponding data. Herein,

the authentication key may be encoded with a receiving system-specific distribution key. In other words, assuming that the enhanced data are scrambled by using the control word, and that the authentication information and the descrambling information are transmitted from the transmitting system, the transmitting system encodes the CW with the authentication key and, then, includes the encoded CW in the entitlement control message (ECM), which is then transmitted to the receiving system. Furthermore, the transmitting system includes the authentication key used for encoding the CW and the entitlement to receive data (or services) of the receiving system (i.e., a standardized serial number of the receiving system that is entitled to receive the corresponding broadcasting service or data) in the entitlement management message (EMM), which is then transmitted to the receiving system.

Accordingly, the authentication unit **808** of the receiving system extracts the identification information of the receiving system and the identification information included in the EMM of the broadcasting service that is being received. Then, the authentication unit **808** determines whether the identification information conform to each other, so as to perform the authentication process. More specifically, if the authentication unit **808** determines that the information conform to each other, then the authentication unit **808** eventually determines that the receiving system is entitled to receive the request broadcasting service.

In yet another example, the authentication unit **808** of the receiving system may be detachably fixed to an external module. In this case, the receiving system is interfaced with the external module through a common interface (CI). In other words, the external module may receive the data scrambled by the receiving system through the common interface, thereby performing the descrambling process of the received data. Alternatively, the external module may also transmit only the information required for the descrambling process to the receiving system. The common interface is configured on a physical layer and at least one protocol layer. Herein, in consideration of any possible expansion of the protocol layer in a later process, the corresponding protocol layer may be configured to have at least one layer that can each provide an independent function.

The external module may either consist of a memory or card having information on the key used for the scrambling process and other authentication information but not including any descrambling function, or consist of a card having the above-mentioned key information and authentication information and including the descrambling function. Both the receiving system and the external module should be authenticated in order to provide the user with the paid broadcasting service provided (or transmitted) from the transmitting system. Therefore, the transmitting system can only provide the corresponding paid broadcasting service to the authenticated pair of receiving system and external module.

Additionally, an authentication process should also be performed between the receiving system and the external module through the common interface. More specifically, the module may communicate with the system manager **815** included in the receiving system through the common interface, thereby authenticating the receiving system. Alternatively, the receiving system may authenticate the module through the common interface. Furthermore, during the authentication process, the module may extract the unique ID of the receiving system and its own unique ID and transmit the extracted IDs to the transmitting system. Thus, the transmitting system may use the transmitted ID values as information determining whether to start the requested service or as payment information. Whenever necessary, the system manager **815** transmits the pay-

ment information to the remote transmitting system through the telecommunication module **819**.

The authentication unit **808** authenticates the corresponding receiving system and/or the external module. Then, if the authentication process is successfully completed, the authentication unit **808** certifies the corresponding receiving system and/or the external module as a legitimate system and/or module entitled to receive the requested paid broadcasting service. In addition, the authentication unit **808** may also receive authentication-associated information from a mobile telecommunications service provider to which the user of the receiving system is subscribed, instead of the transmitting system providing the requested broadcasting service. In this case, the authentication-association information may either be scrambled by the transmitting system providing the broadcasting service and, then, transmitted to the user through the mobile telecommunications service provider, or be directly scrambled and transmitted by the mobile telecommunications service provider. Once the authentication process is successfully completed by the authentication unit **808**, the receiving system may descramble the scrambled broadcasting contents received from the transmitting system. At this point, the descrambling process is performed by the first and second descramblers **804** and **807**. Herein, the first and second descramblers **804** and **807** may be included in an internal module or an external module of the receiving system.

The receiving system is also provided with a common interface for communicating with the external module including the first and second descramblers **804** and **807**, so as to perform the descrambling process. More specifically, the first and second descramblers **804** and **807** may be included in the module or in the receiving system in the form of hardware, middleware or software. Herein, the descramblers **804** and **807** may be included in any one of or both of the module and the receiving system. If the first and second descramblers **804** and **807** are provided inside the receiving system, it is advantageous to have the transmitting system (i.e., at least any one of a service provider and a broadcast station) scramble the corresponding data using the same scrambling method.

Alternatively, if the first and second descramblers **804** and **807** are provided in the external module, it is advantageous to have each transmitting system scramble the corresponding data using different scrambling methods. In this case, the receiving system is not required to be provided with the descrambling algorithm corresponding to each transmitting system. Therefore, the structure and size of receiving system may be simplified and more compact. Accordingly, in this case, the external module itself may be able to provide CA functions, which are uniquely and only provided by each transmitting systems, and functions related to each service that is to be provided to the user. The common interface enables the various external modules and the system manager **815**, which is included in the receiving system, to communicate with one another by a single communication method. Furthermore, since the receiving system may be operated by being connected with at least one or more modules providing different services, the receiving system may be connected to a plurality of modules and controllers.

In order to maintain successful communication between the receiving system and the external module, the common interface protocol includes a function of periodically checking the status of the opposite correspondent. By using this function, the receiving system and the external module is capable of managing the status of each opposite correspondent. This function also reports the user or the transmitting

system of any malfunction that may occur in any one of the receiving system and the external module and attempts the recovery of the malfunction.

In yet another example, the authentication process may be performed through software. More specifically, when a memory card having CAS software downloaded, for example, and stored therein in advanced is inserted in the receiving system, the receiving system receives and loads the CAS software from the memory card so as to perform the authentication process. In this example, the CAS software is read out from the memory card and stored in the first memory **812** of the receiving system. Thereafter, the CAS software is operated in the receiving system as an application program. According to an embodiment of the present invention, the CAS software is mounted on (or stored) in a middleware platform and, then executed. A Java middleware will be given as an example of the middleware included in the present invention. Herein, the CAS software should at least include information required for the authentication process and also information required for the descrambling process.

Therefore, the authentication unit **808** performs authentication processes between the transmitting system and the receiving system and also between the receiving system and the memory card. At this point, as described above, the memory card should be entitled to receive the corresponding data and should include information on a normal receiving system that can be authenticated. For example, information on the receiving system may include a unique number, such as a standardized serial number of the corresponding receiving system. Accordingly, the authentication unit **808** compares the standardized serial number included in the memory card with the unique information of the receiving system, thereby performing the authentication process between the receiving system and the memory card.

If the CAS software is first executed in the Java middleware base, then the authentication between the receiving system and the memory card is performed. For example, when the unique number of the receiving system stored in the memory card conforms to the unique number of the receiving system read from the system manager **815**, then the memory card is verified and determined to be a normal memory card that may be used in the receiving system. At this point, the CAS software may either be installed in the first memory **812** upon the shipping of the present invention, or be downloaded to the first memory **812** from the transmitting system or the module or memory card, as described above. Herein, the descrambling function may be operated by the data broadcasting application manger **816** as an application program.

Thereafter, the CAS software parses the EMM/ECM packets outputted from the demultiplexer **803**, so as to verify whether the receiving system is entitled to receive the corresponding data, thereby obtaining the information required for descrambling (i.e., the CW) and providing the obtained CW to the descramblers **804** and **807**. More specifically, the CAS software operating in the Java middleware platform first reads out the unique (or serial) number of the receiving system from the corresponding receiving system and compares it with the unique number of the receiving system transmitted through the EMM, thereby verifying whether the receiving system is entitled to receive the corresponding data. Once the receiving entitlement of the receiving system is verified, the corresponding broadcasting service information transmitted to the ECM and the entitlement of receiving the corresponding broadcasting service are used to verify whether the receiving system is entitled to receive the corresponding broadcasting service. Once the receiving system is verified to be entitled to receive the corresponding broadcasting service, the authenti-

cation key transmitted to the EMM is used to decode (or decipher) the encoded CW, which is transmitted to the ECM, thereby transmitting the decoded CW to the descramblers **804** and **807**. Each of the descramblers **804** and **807** uses the CW to descramble the broadcasting service.

Meanwhile, the CAS software stored in the memory card may be expanded in accordance with the paid service which the broadcast station is to provide. Additionally, the CAS software may also include other additional information other than the information associated with the authentication and descrambling. Furthermore, the receiving system may download the CAS software from the transmitting system so as to upgrade (or update) the CAS software originally stored in the memory card. As described above, regardless of the type of broadcast receiving system, as long as an external memory interface is provided, the present invention may embody a CAS system that can meet the requirements of all types of memory card that may be detachably fixed to the receiving system. Thus, the present invention may realize maximum performance of the receiving system with minimum fabrication cost, wherein the receiving system may receive paid broadcasting contents such as broadcast programs, thereby acknowledging and regarding the variety of the receiving system. Moreover, since only the minimum application program interface is required to be embodied in the embodiment of the present invention, the fabrication cost may be minimized, thereby eliminating the manufacturer's dependence on CAS manufacturers. Accordingly, fabrication costs of CAS equipments and management systems may also be minimized.

Meanwhile, the descramblers **804** and **807** may be included in the module either in the form of hardware or in the form of software. In this case, the scrambled data that being received are descrambled by the module and then demodulated. Also, if the scrambled data that are being received are stored in the third memory **818**, the received data may be descrambled and then stored, or stored in the memory at the point of being received and then descrambled later on prior to being played (or reproduced). Thereafter, in case scramble/descramble algorithms are provided in the storage controller **817**, the storage controller **817** scrambles the data that are being received once again and then stores the re-scrambled data to the third memory **818**.

In yet another example, the descrambled broadcasting contents (transmission of which being restricted) are transmitted through the broadcasting network. Also, information associated with the authentication and descrambling of data in order to disable the receiving restrictions of the corresponding data are transmitted and/or received through the telecommunications module **819**. Thus, the receiving system is able to perform reciprocal (or two-way) communication. The receiving system may either transmit data to the telecommunication module within the transmitting system or be provided with the data from the telecommunication module within the transmitting system. Herein, the data correspond to broadcasting data that are desired to be transmitted to or from the transmitting system, and also unique information (i.e., identification information) such as a serial number of the receiving system or MAC address.

The telecommunication module **819** included in the receiving system provides a protocol required for performing reciprocal (or two-way) communication between the receiving system, which does not support the reciprocal communication function, and the telecommunication module included in the transmitting system. Furthermore, the receiving system configures a protocol data unit (PDU) using a tag-length-value (TLV) coding method including the data that are to be

transmitted and the unique information (or ID information). Herein, the tag field includes indexing of the corresponding PDU. The length field includes the length of the value field. And, the value field includes the actual data that are to be transmitted and the unique number (e.g., identification number) of the receiving system.

The receiving system may configure a platform that is equipped with the Java platform and that is operated after downloading the Java application of the transmitting system to the receiving system through the network. In this case, a structure of downloading the PDU including the tag field arbitrarily defined by the transmitting system from a storage means included in the receiving system and then transmitting the downloaded PDU to the telecommunication module **819** may also be configured. Also, the PDU may be configured in the Java application of the receiving system and then outputted to the telecommunication module **819**. The PDU may also be configured by transmitting the tag value, the actual data that are to be transmitted, the unique information of the corresponding receiving system from the Java application and by performing the TLV coding process in the receiving system. This structure is advantageous in that the firmware of the receiving system is not required to be changed even if the data (or application) desired by the transmitting system is added.

The telecommunication module within the transmitting system either transmits the PDU received from the receiving system through a wireless data network or configures the data received through the network into a PDU which is transmitted to the host. At this point, when configuring the PDU that is to be transmitted to the host, the telecommunication module within the transmitting end may include unique information (e.g., IP address) of the transmitting system which is located in a remote location. Additionally, in receiving and transmitting data through the wireless data network, the receiving system may be provided with a common interface, and also provided with a WAP, CDMA 1× EV-DO, which can be connected through a mobile telecommunication base station, such as CDMA and GSM, and also provided with a wireless LAN, mobile internet, WiBro, WiMax, which can be connected through an access point. The above-described receiving system corresponds to the system that is not equipped with a telecommunication function. However, a receiving system equipped with telecommunication function does not require the telecommunication module **819**.

The broadcasting data being transmitted and received through the above-described wireless data network may include data required for performing the function of limiting data reception. Meanwhile, the demultiplexer **803** receives either the real-time data outputted from the demodulating unit **802** or the data read from the third memory **818**, thereby performing demultiplexing. In this embodiment of the present invention, the demultiplexer **803** performs demultiplexing on the enhanced data packet. Similar process steps have already been described earlier in the description of the present invention. Therefore, a detailed of the process of demultiplexing the enhanced data will be omitted for simplicity.

The first descrambler **804** receives the demultiplexed signals from the demultiplexer **803** and then descrambles the received signals. At this point, the first descrambler **804** may receive the authentication result received from the authentication unit **808** and other data required for the descrambling process, so as to perform the descrambling process. The audio decoder **805** and the video decoder **806** receive the signals descrambled by the first descrambler **804**, which are then decoded and outputted. Alternatively, if the first descrambler **804** did not perform the descrambling process, then the audio

decoder **805** and the video decoder **806** directly decode and output the received signals. In this case, the decoded signals are received and then descrambled by the second descrambler **807** and processed accordingly.

As described above, the channel equalizer and method of processing broadcast signal in receiving system according to the present invention has the following advantages. More specifically, the present invention according to the present invention is highly protected against (or resistant to) any error that may occur when transmitting supplemental data through a channel. And, the present invention is also highly compatible to the conventional receiving system. Moreover, the present invention may also receive the supplemental data without any error even in channels having severe ghost effect and noise.

Additionally, the transmitting system of the present invention configures the enhanced data packet to include at least any one of the enhanced data, which include information, and the known data, which are known by the transmitting system and the receiving system, and transmits the configured enhanced data packet. The receiving system used the known data for channel equalization, thereby enhancing the receiving performance. Particularly, when the plurality of enhanced data packets are transmitted in hierarchically differentiated areas, the CIR of each area is estimated in accordance with the characteristic of each area, so as to perform channel equalization, thereby enhancing the channel equalizing performance. Furthermore, the present invention is even more effective when applied to mobile and portable receivers, which are also liable to a frequent change in channel and which require protection (or resistance) against intense noise.

It will be apparent to those skilled in the art that various modifications and variations can be made in the present invention without departing from the spirit or scope of the inventions. Thus, it is intended that the present invention covers the modifications and variations of this invention provided they come within the scope of the appended claims and their equivalents.

What is claimed is:

1. A broadcast receiver for processing a broadcast signal, the broadcast receiver comprising:
 - a tuner for receiving the broadcast signal comprising enhanced data and known data sequences, wherein the broadcast signal is processed in a broadcast transmitter by a process comprising:
 - randomizing enhanced data,
 - generating a Reed-Solomon (RS) frame including the randomized enhanced data,
 - encoding data in the RS frame at a coding rate of $1/H$, wherein H is an integer that is greater than 1,
 - mapping a portion of the encoded data into a data group,
 - adding the known data sequences to the data group and inserting MPEG header place holders into the data group, wherein the data group includes a plurality of regions, and a specific region of the plurality of regions includes the known data sequences,
 - replacing the MPEG header place holders with MPEG header data and outputting enhanced data packets, and
 - randomizing the MPEG header data in the enhanced data packets;
 - a detector for detecting at least one of the known data sequences included in the specific region of the data group;
 - an equalizer for compensating a channel distortion in the received broadcast signal using the at least one of the

37

known data sequences to generate a channel distortion compensated broadcast signal; and
 a decoder for decoding the enhanced data in the channel distortion compensated broadcast signal,
 wherein the RS frame comprises:
 '187×N' bytes including the randomized enhanced data;
 P bytes of RS parity data added to a bottom of each column of the '187×N' bytes; and
 2 bytes of cyclic redundancy check (CRC) checksum data added to a right end of each row of the '(187+P)×N' bytes, wherein both P and N are *integers that are greater than 1*.

2. The broadcast receiver of claim 1, wherein the decoder comprises:
 a first decoder for turbo-decoding the enhanced data; and
 a second decoder for CRC-decoding and RS-decoding the turbo-decoded enhanced data.

3. The broadcast receiver of claim 1, wherein the data group further includes signaling data including data group information.

4. A method of processing a broadcast signal in a broadcast receiver, the method comprising:
 receiving, by a tuner, the broadcast signal comprising enhanced data and known data sequences, wherein the broadcast signal is processed in a broadcast transmitter by a *process comprising*:
 randomizing enhanced data,
 generating a Reed Solomon (RS) frame including the randomized enhanced data,
 encoding data in the RS frame at a coding rate of 1/H,
 wherein H is an *integer that is greater than 1*,
 mapping a portion of the encoded data into a data group,
 adding known data sequences to the data group and inserting MPEG header place holders into the data group, wherein the data group includes a plurality of

38

regions, and a specific region of the plurality of regions includes the known data sequences,
 replacing the MPEG header place holders with MPEG header data and outputting enhanced data packets,
 and
 randomizing the MPEG header data in the enhanced data packets;
 detecting at least one of the known data sequences included in the specific region of the data group;
 compensating, by an equalizer, a channel distortion in the received broadcast signal using the at least one of the known data sequences to generate a channel distortion compensated broadcast signal; and
 decoding, by a decoder, the enhanced data in the channel distortion compensated broadcast signal,
 wherein the RS frame comprises:
 '187×N' bytes including the randomized enhanced data,
 P bytes of RS parity data added to a bottom of each column of the '187×N' bytes, and
 2 bytes of cyclic redundancy check (CRC) checksum data added to a right end of each row of the '(187+P)×N' bytes, wherein both P and N are *integers that are greater than 1*.

5. The method of claim 4, wherein decoding the enhanced data comprises:
 turbo-decoding the enhanced data; and
 CRC-decoding and RS-decoding the turbo-decoded enhanced data.

6. The method of claim 4, wherein the data group further includes signaling data including data group information.

7. *The broadcast receiver of claim 1, wherein the broadcast signal includes known data sequences that are periodically located.*

8. *The method of claim 4, wherein the broadcast signal includes known data sequences that are periodically located.*

* * * * *