



US00RE45896E

(19) **United States**
(12) **Reissued Patent**
Stout et al.

(10) **Patent Number:** **US RE45,896 E**
(45) **Date of Reissued Patent:** **Feb. 23, 2016**

(54) **SYSTEMS AND METHODS FOR PROVIDING A CATHETER ASSEMBLY**

(71) Applicants: **Marty L. Stout**, South Jordan, UT (US); **Weston F. Harding**, Lehi, UT (US); **S. Ray Isaacson**, Roy, UT (US); **Yiping Ma**, Layton, UT (US); **Austin Jason McKinnon**, Herriman, UT (US)

(72) Inventors: **Marty L. Stout**, South Jordan, UT (US); **Weston F. Harding**, Lehi, UT (US); **S. Ray Isaacson**, Roy, UT (US); **Yiping Ma**, Layton, UT (US); **Austin Jason McKinnon**, Herriman, UT (US)

(73) Assignee: **Becton, Dickinson and Company**, Franklin Lakes, NJ (US)

(21) Appl. No.: **14/502,544**

(22) Filed: **Sep. 30, 2014**

Related U.S. Patent Documents

Reissue of:

(64) Patent No.: **8,679,063**
Issued: **Mar. 25, 2014**
Appl. No.: **13/042,154**
Filed: **Mar. 7, 2011**

U.S. Applications:

(63) Continuation-in-part of application No. 12/703,336, filed on Feb. 10, 2010, now Pat. No. 8,469,928, and a continuation-in-part of application No. 12/544,625, filed on Aug. 20, 2009, now Pat. No. 8,388,583.

(60) Provisional application No. 61/151,775, filed on Feb. 11, 2009.

(51) **Int. Cl.**
A61M 5/178 (2006.01)
A61M 25/00 (2006.01)

(Continued)

(52) **U.S. Cl.**
CPC **A61M 25/0045** (2013.01); **A61M 25/0009** (2013.01); **A61M 25/0097** (2013.01);

(Continued)

(58) **Field of Classification Search**
USPC 604/164.01, 164.02, 167.01, 167.02, 604/167.03, 167.04, 167.05, 167.06, 604/168.01, 224–226
See application file for complete search history.

(56) **References Cited**

U.S. PATENT DOCUMENTS

4,387,879 A 6/1983 Tauschinski
4,449,693 A 5/1984 Gereg

(Continued)

FOREIGN PATENT DOCUMENTS

CA 2133053 A1 3/1995
WO WO 99/34849 7/1999

(Continued)

OTHER PUBLICATIONS

Silva, Elson, Email Regarding “Respecting Hydrology Science and IP Rights—US Pat. Application 20110130728,” pp. 1-6, Jun. 2, 2011.

Primary Examiner — Cary Wehner

(74) *Attorney, Agent, or Firm* — Jeanne Lukasavage; Craig Metcalf; Kirton McConkie

(57) **ABSTRACT**

A system for controlling fluid flow in a catheter assembly is disclosed herein. An intravenous catheter assembly has a catheter adapter and a needle hub, and the catheter adapter has an inner lumen. A septum is disposed within a portion of the inner lumen, and a slit is formed through the septum. A Parylene coating is disposed within the slit of the septum, the Parylene coating has a thickness of between approximately 0.00005 to 0.0005 millimeters. An introducer needle has a first end coupled to the needle hub and the second end extending through the inner lumen of the catheter adapter. A middle portion of the introducer needle is positioned within a portion of the septum.

17 Claims, 23 Drawing Sheets

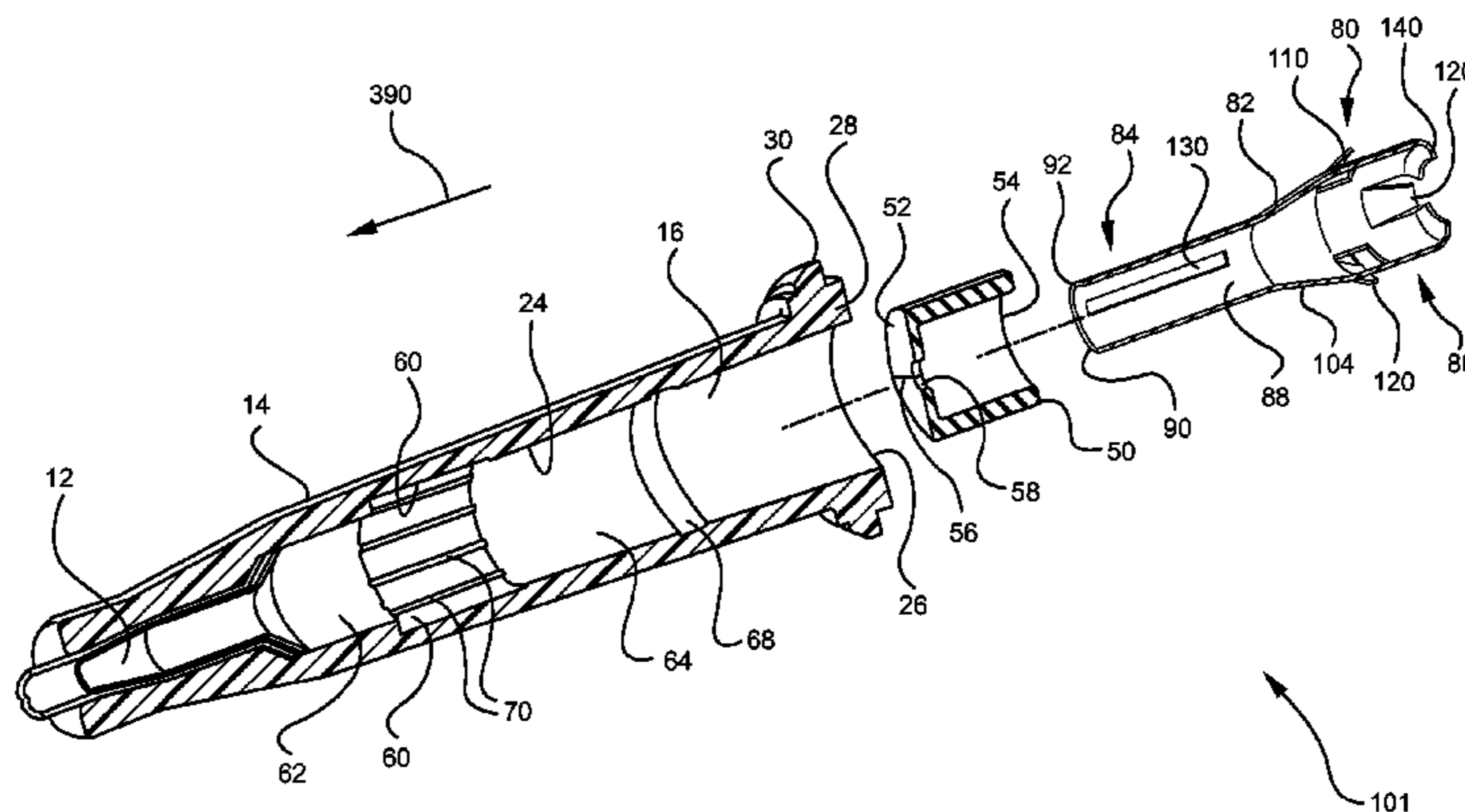

US RE45,896 E

- | | | | | |
|------|--|---|--|--|
| (51) | Int. Cl.
<i>A61M 39/06</i> (2006.01)
<i>A61M 25/06</i> (2006.01)
<i>A61M 39/26</i> (2006.01) | 5,651,772 A
5,657,963 A
5,697,915 A
5,738,144 A
5,749,861 A
5,806,831 A
5,817,069 A
5,911,710 A
5,954,698 A
5,967,490 A
6,039,302 A
6,077,244 A
6,117,108 A
6,171,287 B1
6,273,869 B1
6,485,473 B1
6,575,960 B2
6,595,981 B2
6,699,221 B2
6,740,063 B2
6,837,884 B2 *
6,883,778 B1
7,008,404 B2
7,347,839 B2
7,396,346 B2
7,470,254 B2
7,736,339 B2
7,914,494 B2
2005/0283093 A1 *
2007/0083162 A1
2007/0233007 A1 *
2008/0039796 A1
2008/0108944 A1 *
2008/0132832 A1 *
2008/0132877 A1 *
2010/0204648 A1
2010/0204675 A1
2011/0021994 A1 *
2011/0046570 A1
2011/0319820 A1 * | 7/1997
8/1997
12/1997
4/1998
5/1998
9/1998
10/1998
6/1999
9/1999
10/1999
3/2000
6/2000
9/2000
1/2001
8/2001
11/2002
6/2003
7/2003
3/2004
5/2004
1/2005
4/2005
3/2006
3/2008
7/2008
12/2008
6/2010
3/2011
12/2005
4/2007
10/2007
2/2008
5/2008
6/2008
6/2008
8/2010
8/2010
1/2011
2/2011
12/2011 | Arnett
Hinchliffe et al.
Lynn
Rogers
Guala et al.
Paradis
Arnett
Barry et al.
Pike
Pike 251/149.1
Cote, Sr. et al.
Botich et al.
Woehr et al.
Lynn et al.
Vaillancourt
Lynn
Becker et al.
Huet
Vaillancourt
Lynn
Woloszko 606/32
Newton et al. 251/149.1
Nakajima 604/158
Hiejima
Nakajima
Basta et al.
Woehr et al.
Hiejima
Conway et al. 600/576
O'Reagan et al. 604/167.03
Adams 604/168.01
Nakajima
Woehr et al. 604/164.08
McKinnon et al. 604/93.01
McKinnon et al. 604/500
Stout et al.
Woehr et al.
Anderson et al. 604/164.01
Stout et al.
Teoh et al. 604/122 |
|------|--|---|--|--|

(56) **References Cited**

U.S. PATENT DOCUMENTS

4,758,225 A	7/1988	Cox et al.
4,842,591 A	6/1989	Luther
4,874,377 A	10/1989	Newgard et al.
4,917,668 A	4/1990	Haindl
4,935,010 A	6/1990	Cox et al.
5,032,116 A *	7/1991	Peterson et al. 604/168.01
5,041,097 A	8/1991	Johnson
5,053,014 A	10/1991	Van Heugten
5,062,836 A	11/1991	Wendell
5,064,416 A	11/1991	Newgard et al.
5,084,023 A	1/1992	Lemieux
5,085,645 A	2/1992	Purdy et al. 604/167.03
5,108,374 A	4/1992	Lemieux
5,127,905 A	7/1992	Lemieux
5,154,703 A	10/1992	Bonaldo
5,156,596 A	10/1992	Balbierz et al.
5,234,410 A	8/1993	Graham et al.
5,295,969 A	3/1994	Fischell et al.
5,330,435 A	7/1994	Vaillancourt
5,350,363 A	9/1994	Goode et al.
5,352,205 A	10/1994	Dales et al.
5,405,323 A	4/1995	Rogers et al.
5,456,675 A	10/1995	Wolbring et al.
5,487,728 A	1/1996	Vaillancourt
5,520,666 A	5/1996	Choudhury et al.
5,549,566 A	8/1996	Elias et al.
5,549,577 A	8/1996	Siegel et al.
5,575,769 A	11/1996	Vaillancourt
5,613,663 A	3/1997	Schmidt et al.

FOREIGN PATENT DOCUMENTS

WO	WO 2008/022258 A2	2/2008
WO	WO 2008/045761 A2	4/2008

* cited by examiner

FIG. 1 Prior Art
Amended

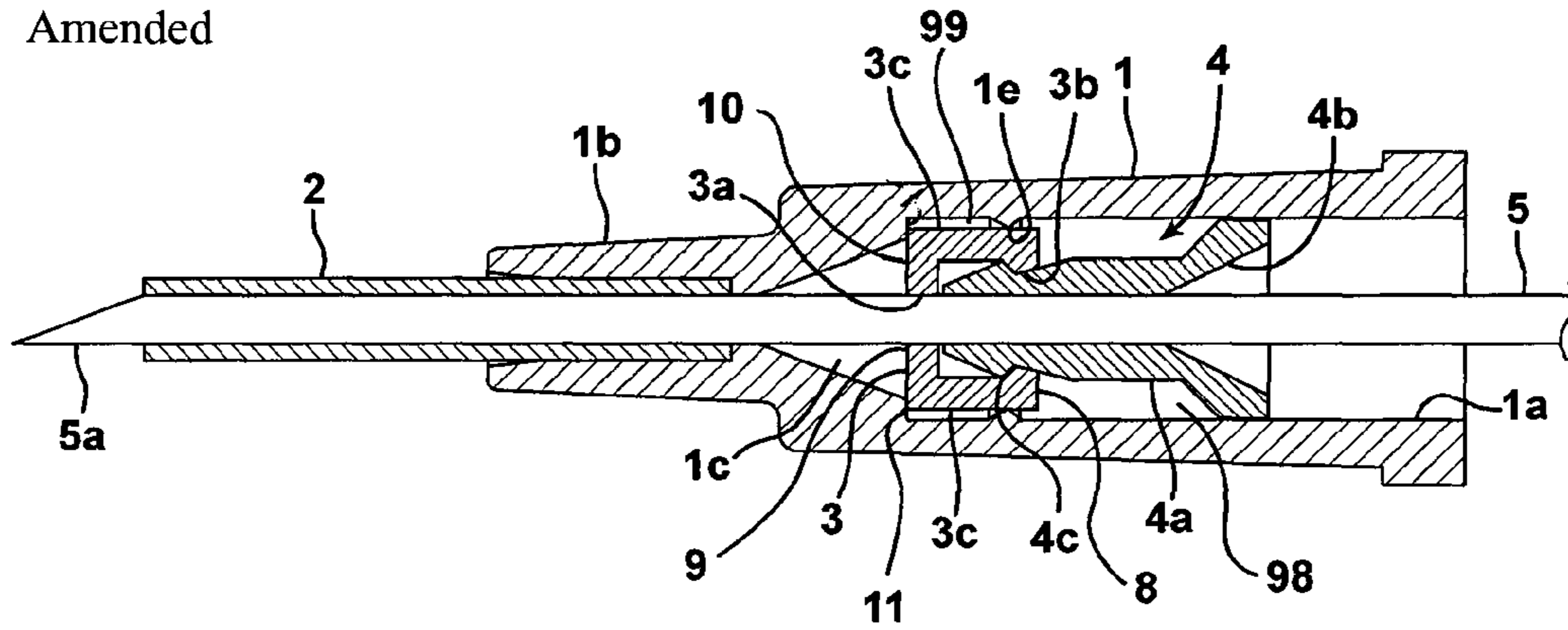

FIG. 2 Prior Art

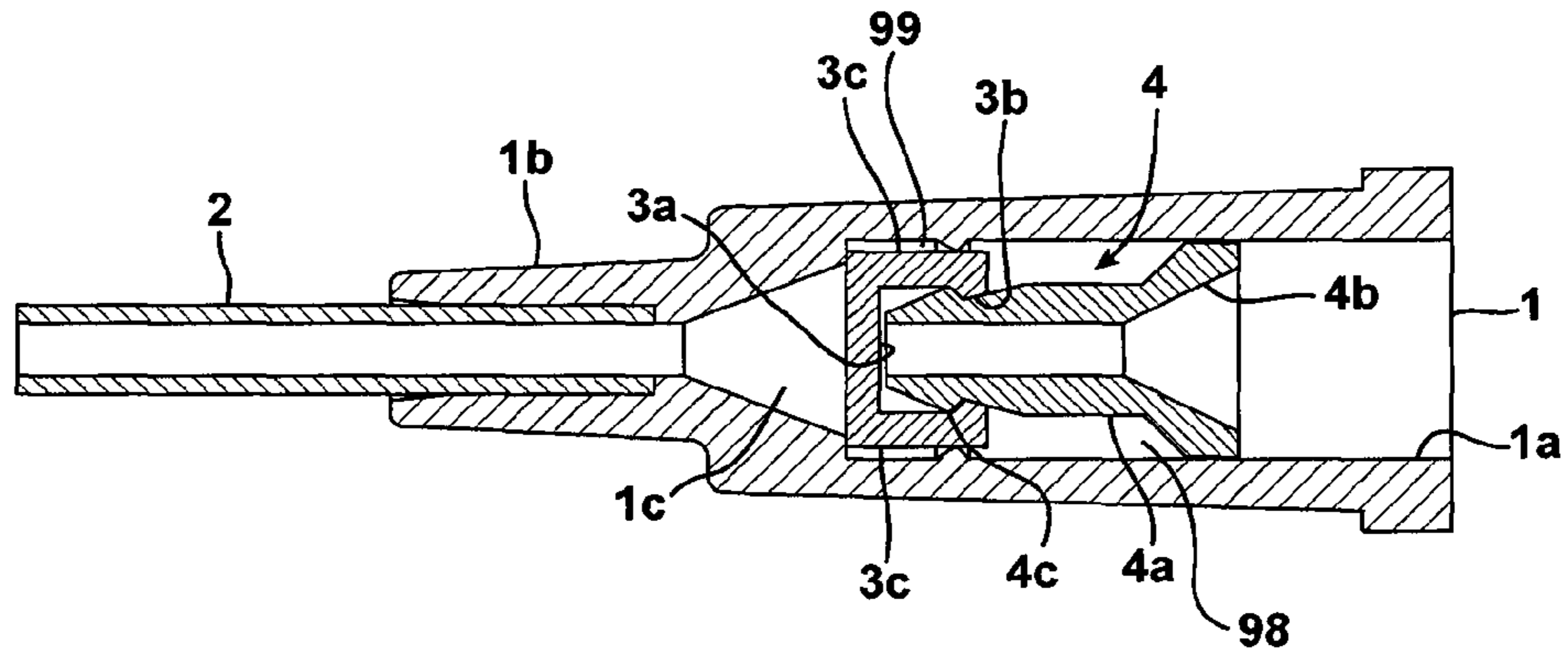
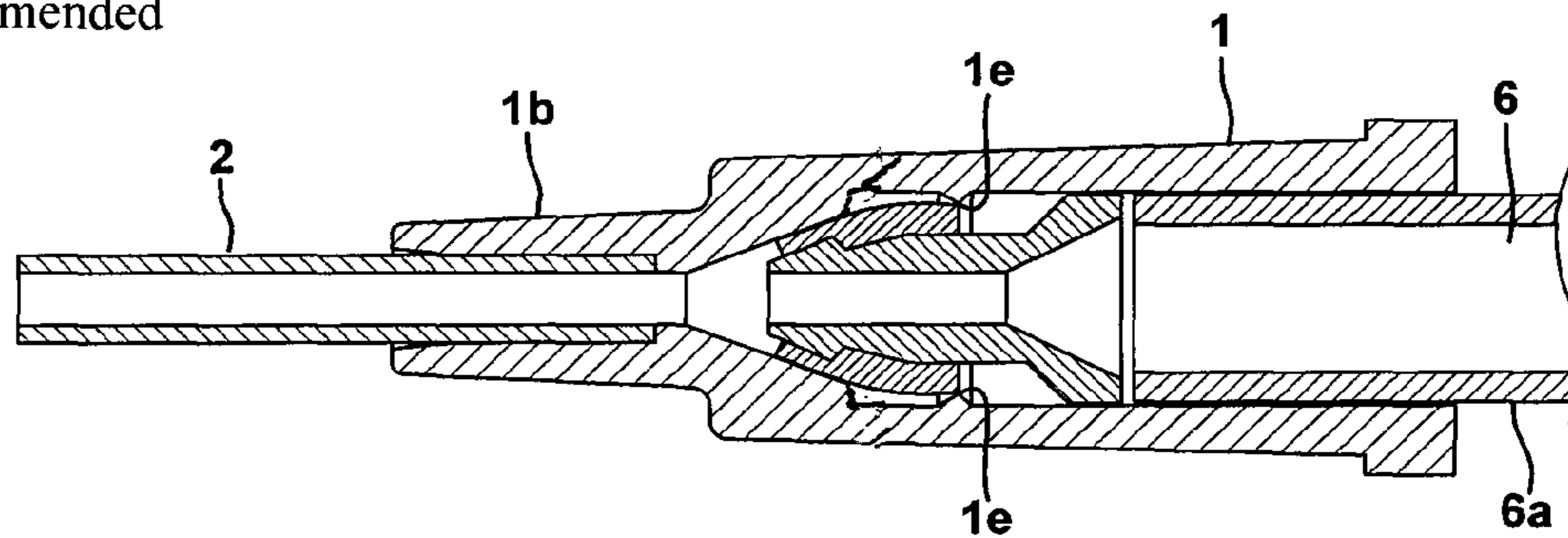

FIG. 3 Prior Art
Amended



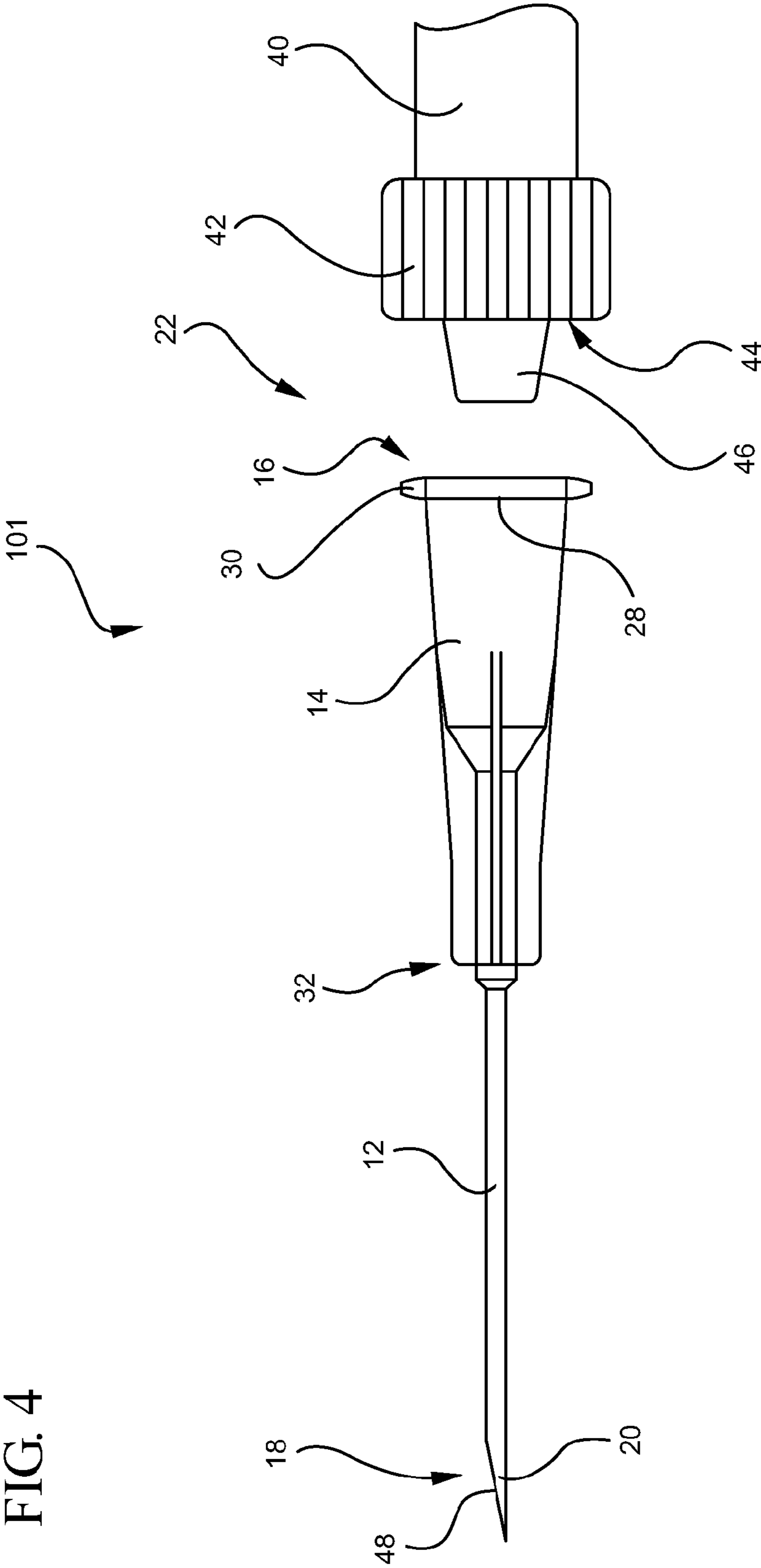
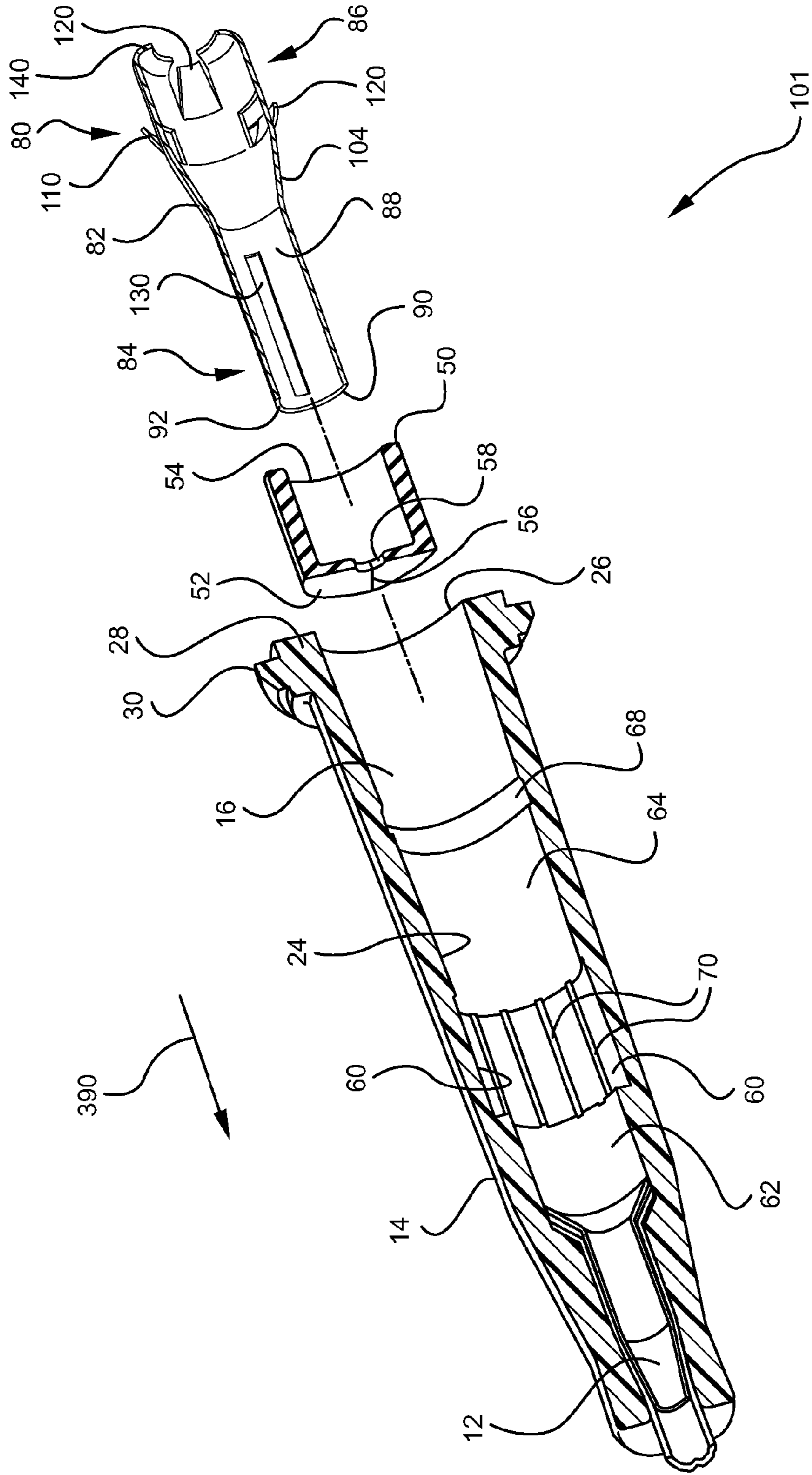

FIG. 5A



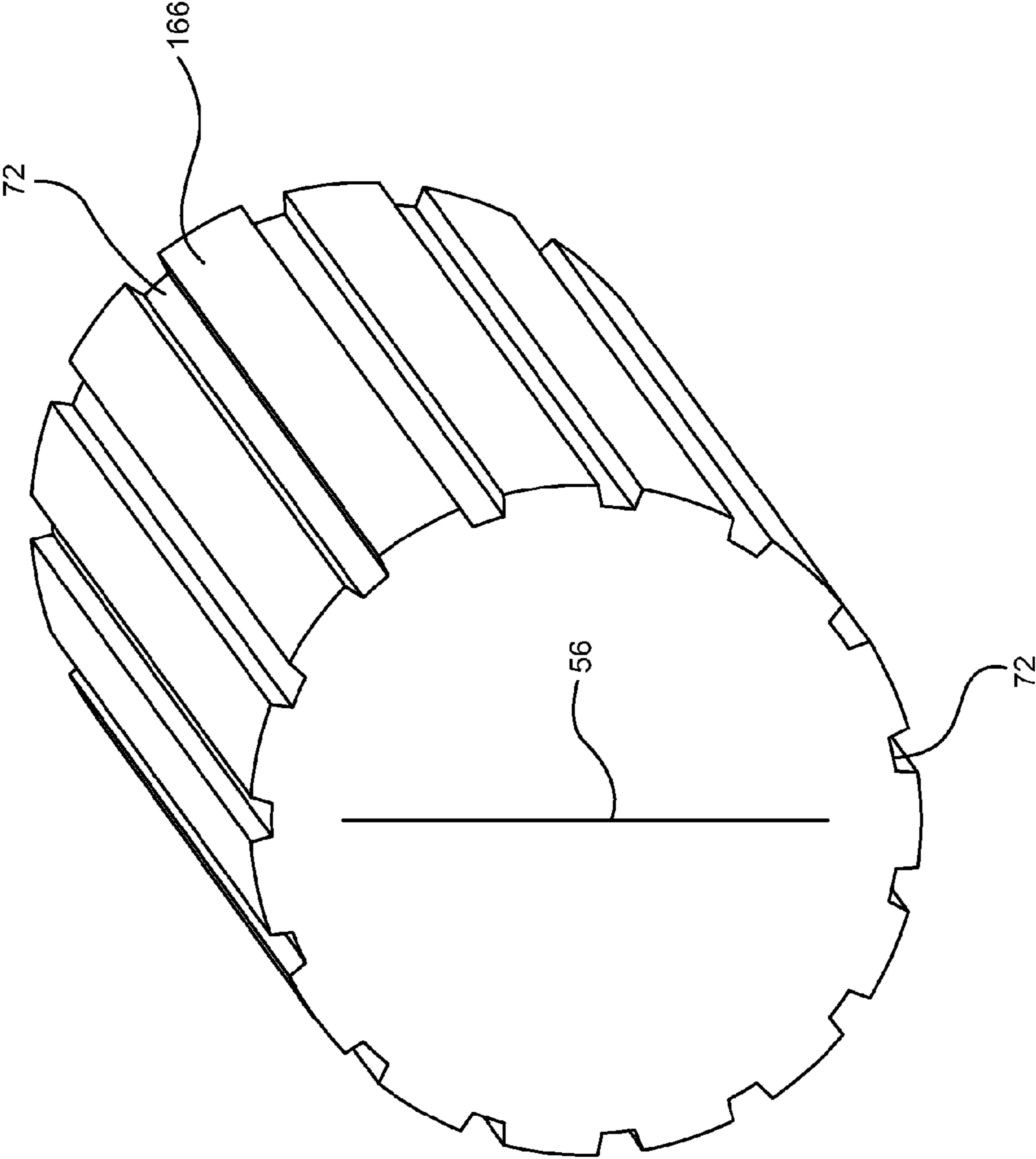
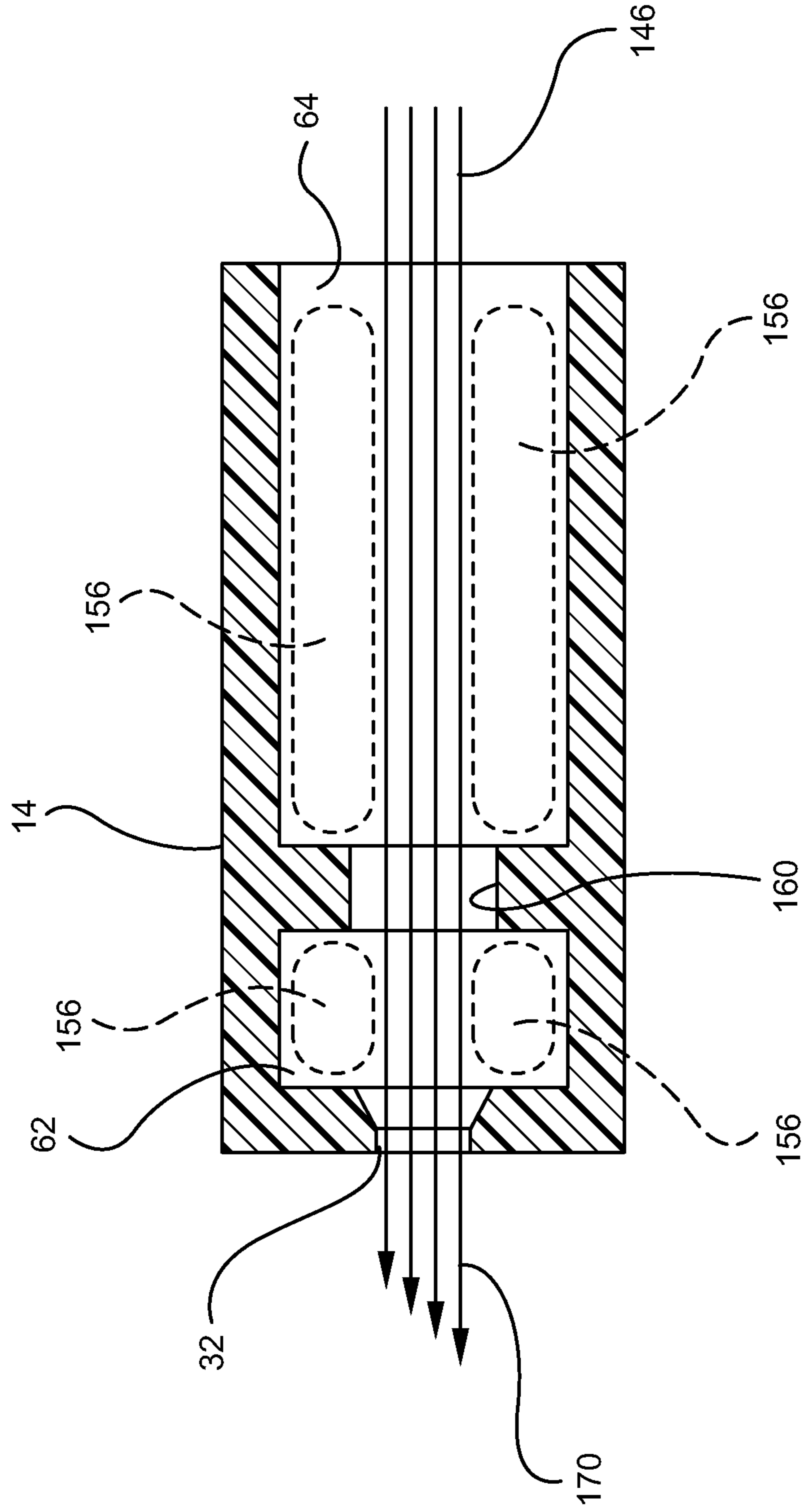

FIG. 5B

FIG. 6A



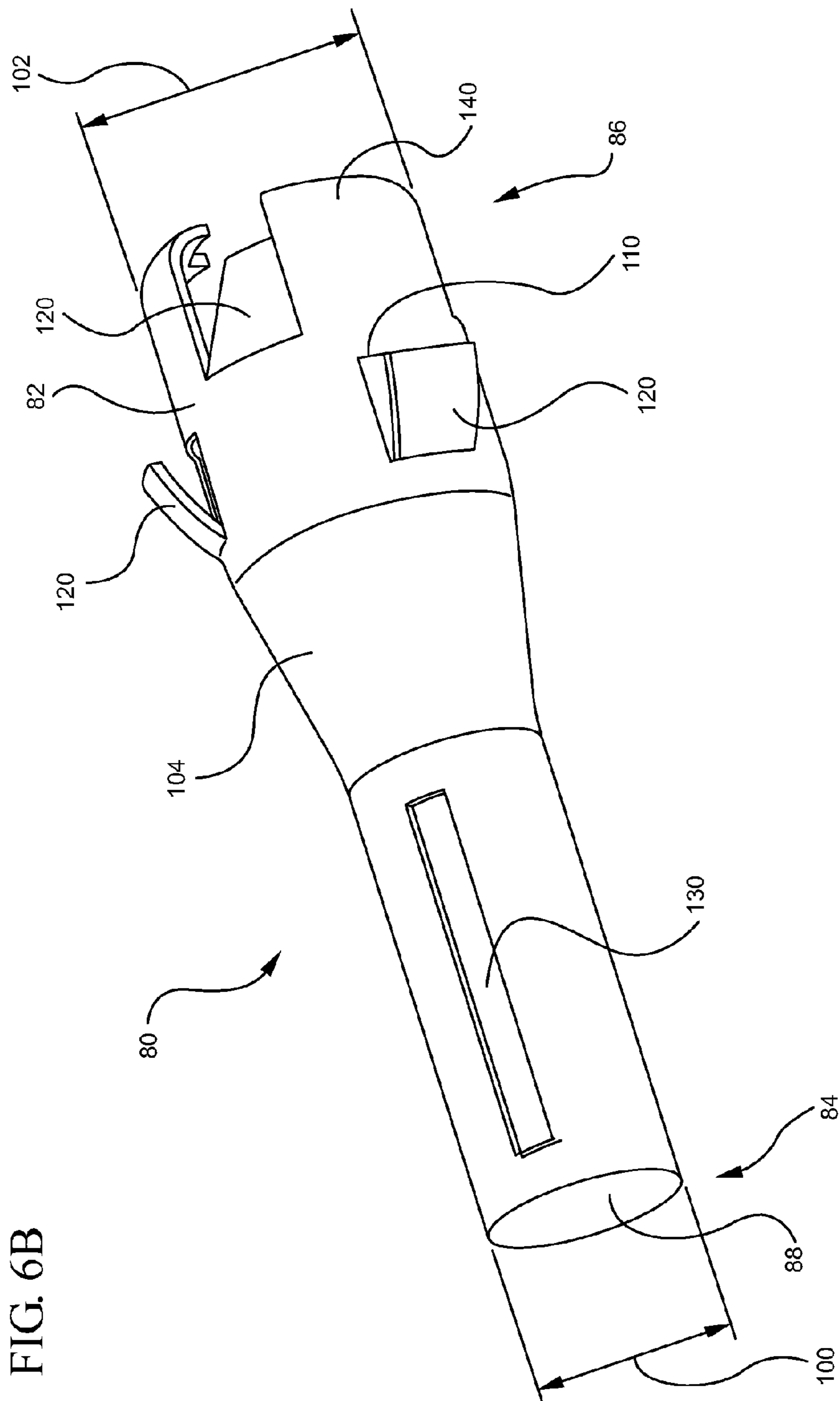

FIG. 6B

FIG. 6C

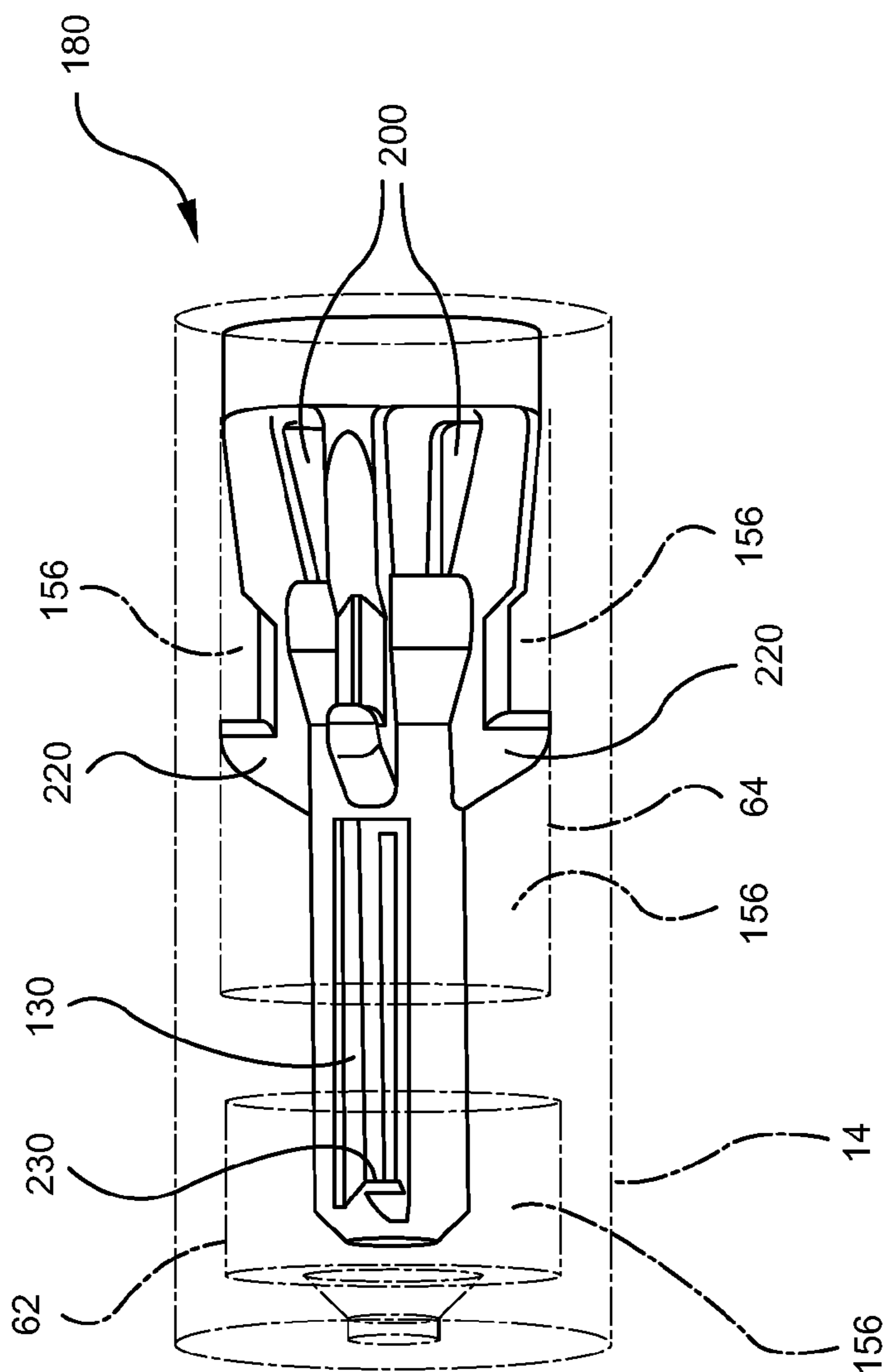
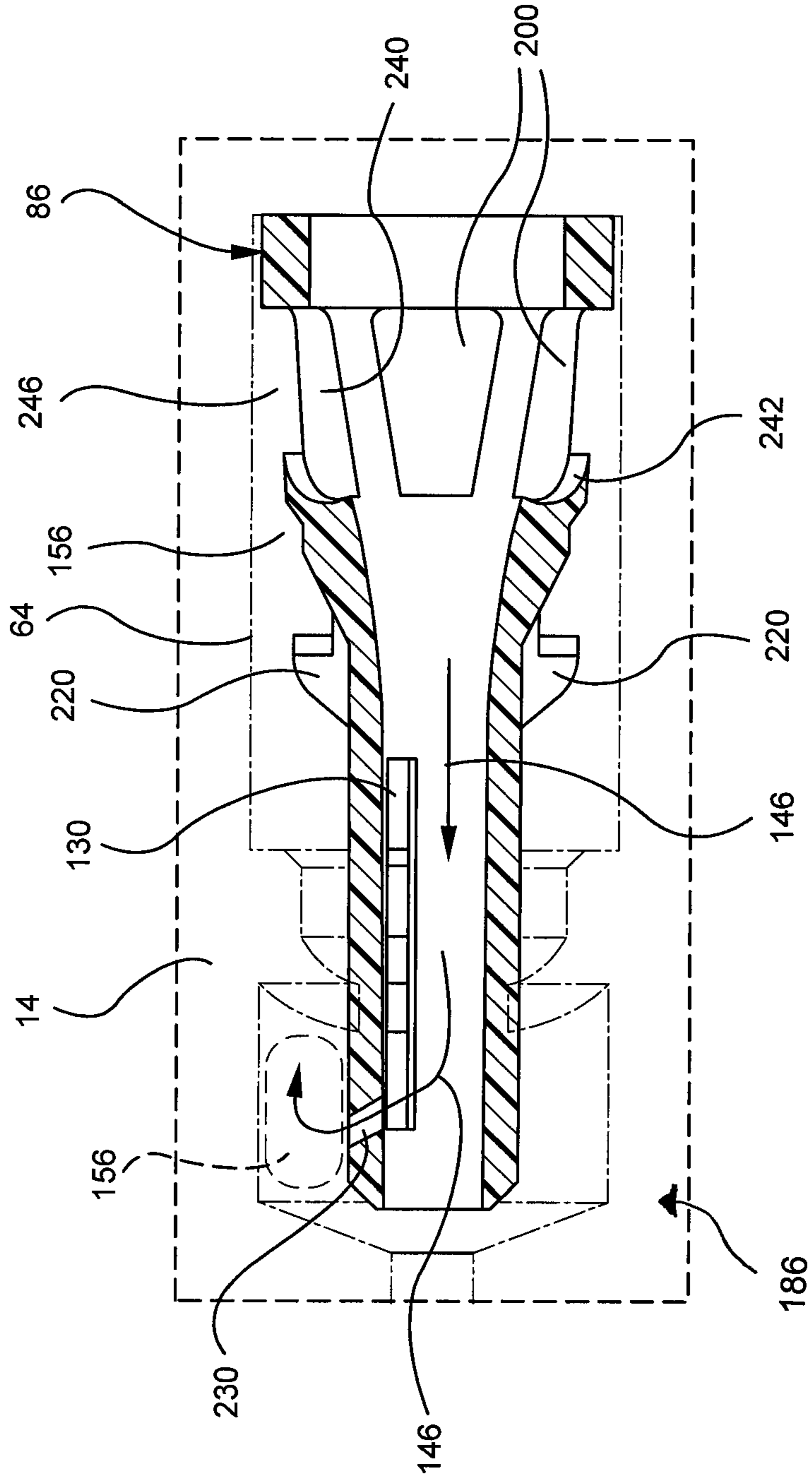

FIG. 6D
Amended



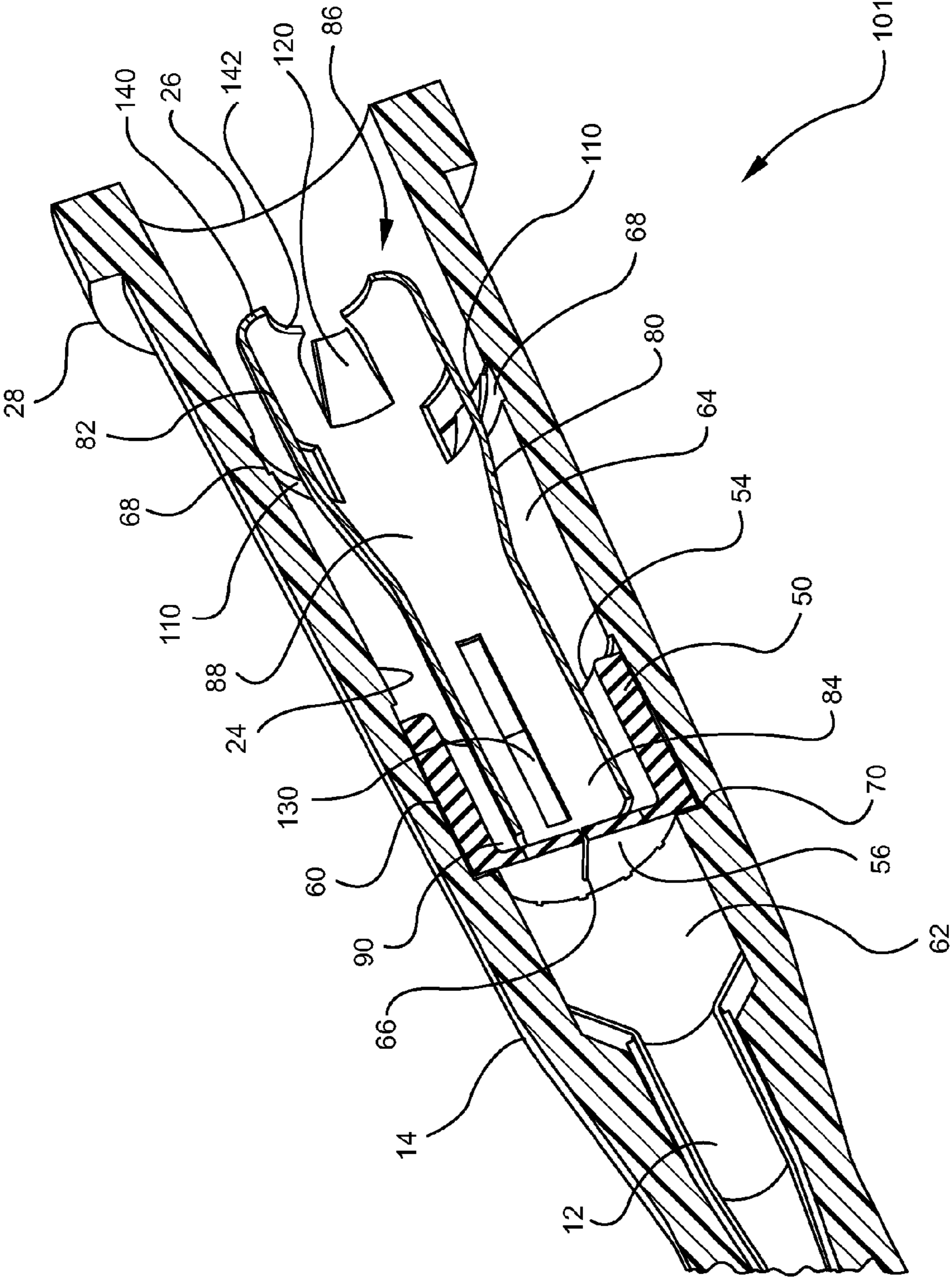

FIG. 7

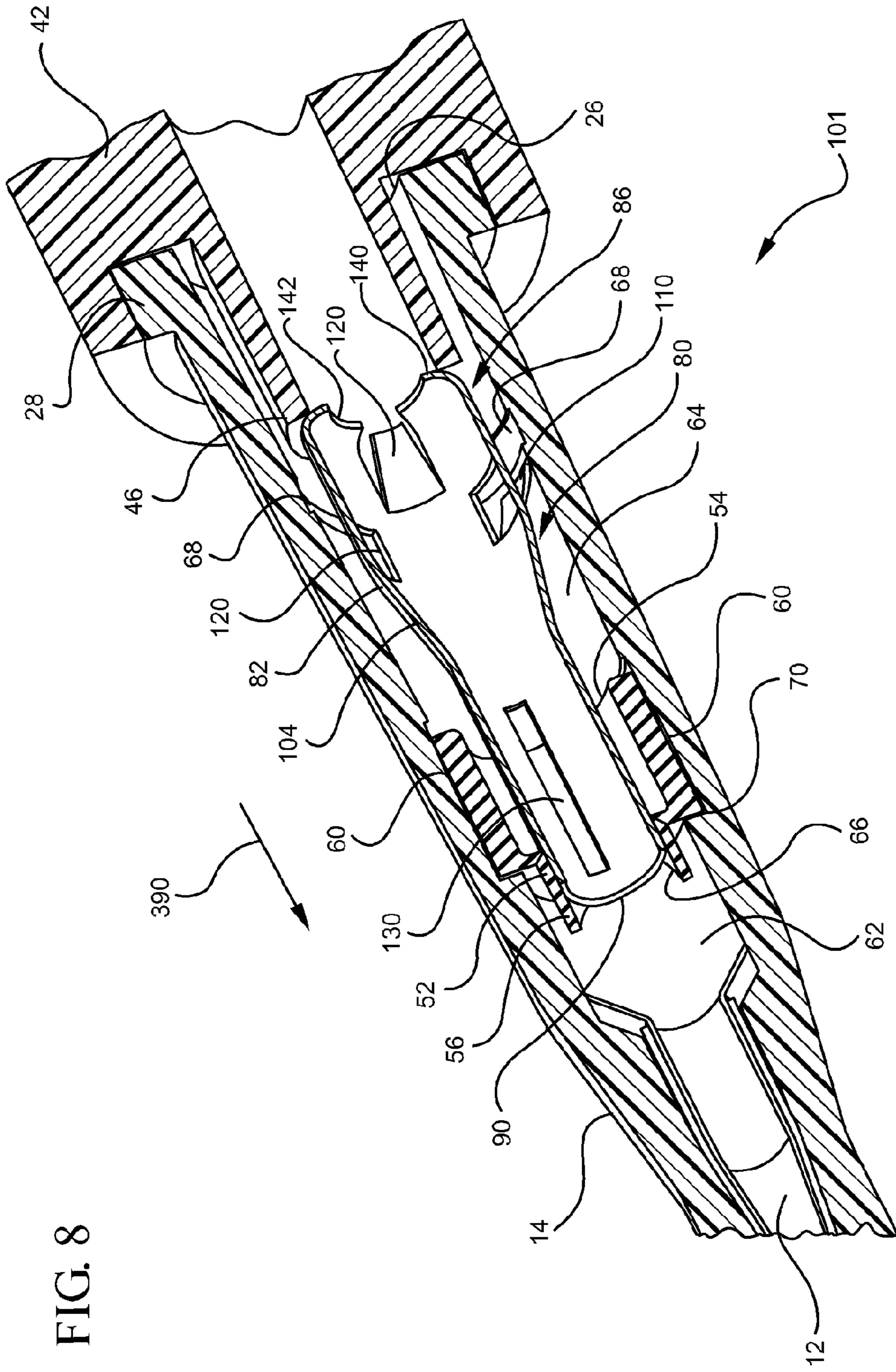

FIG. 9

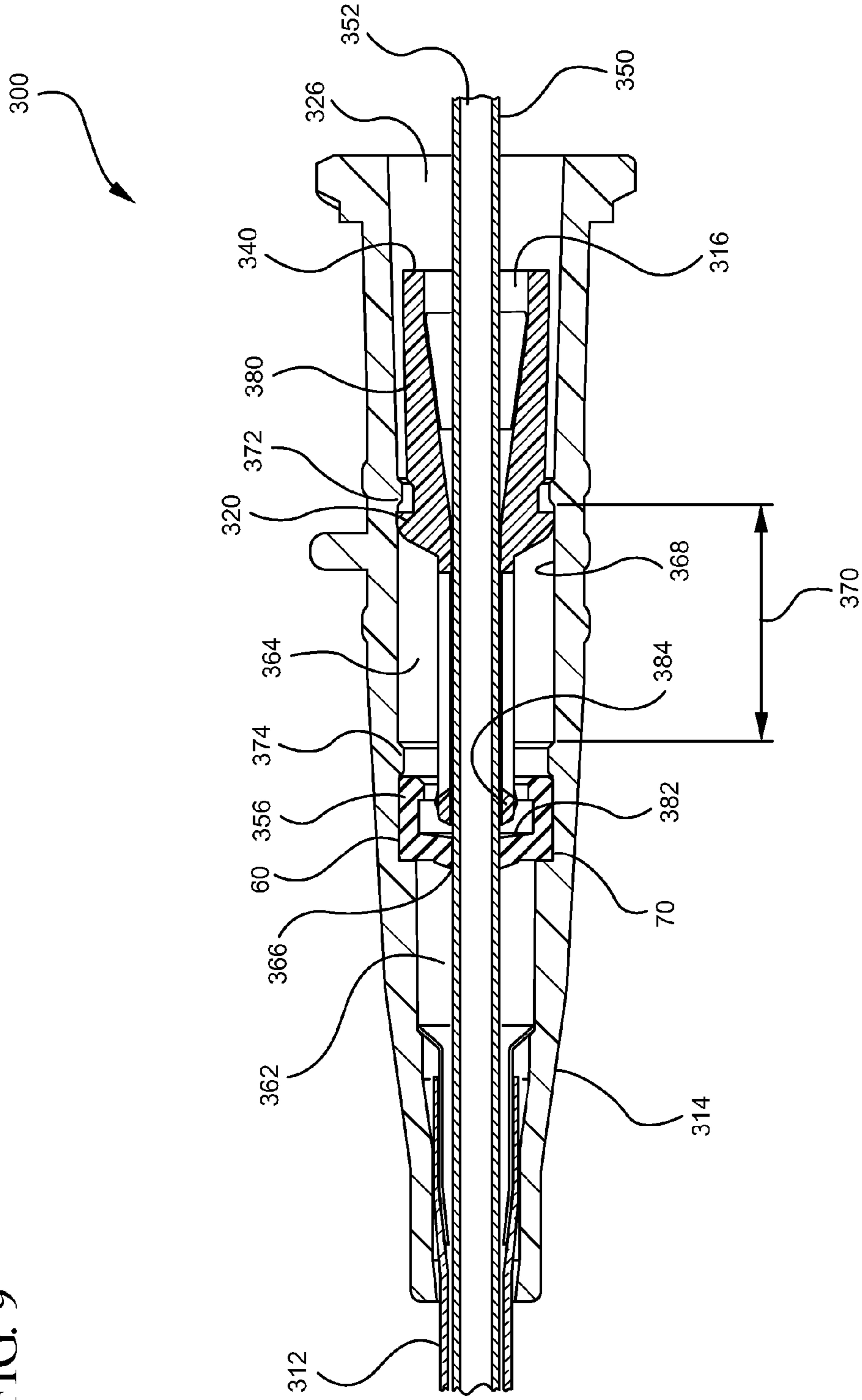

FIG. 10

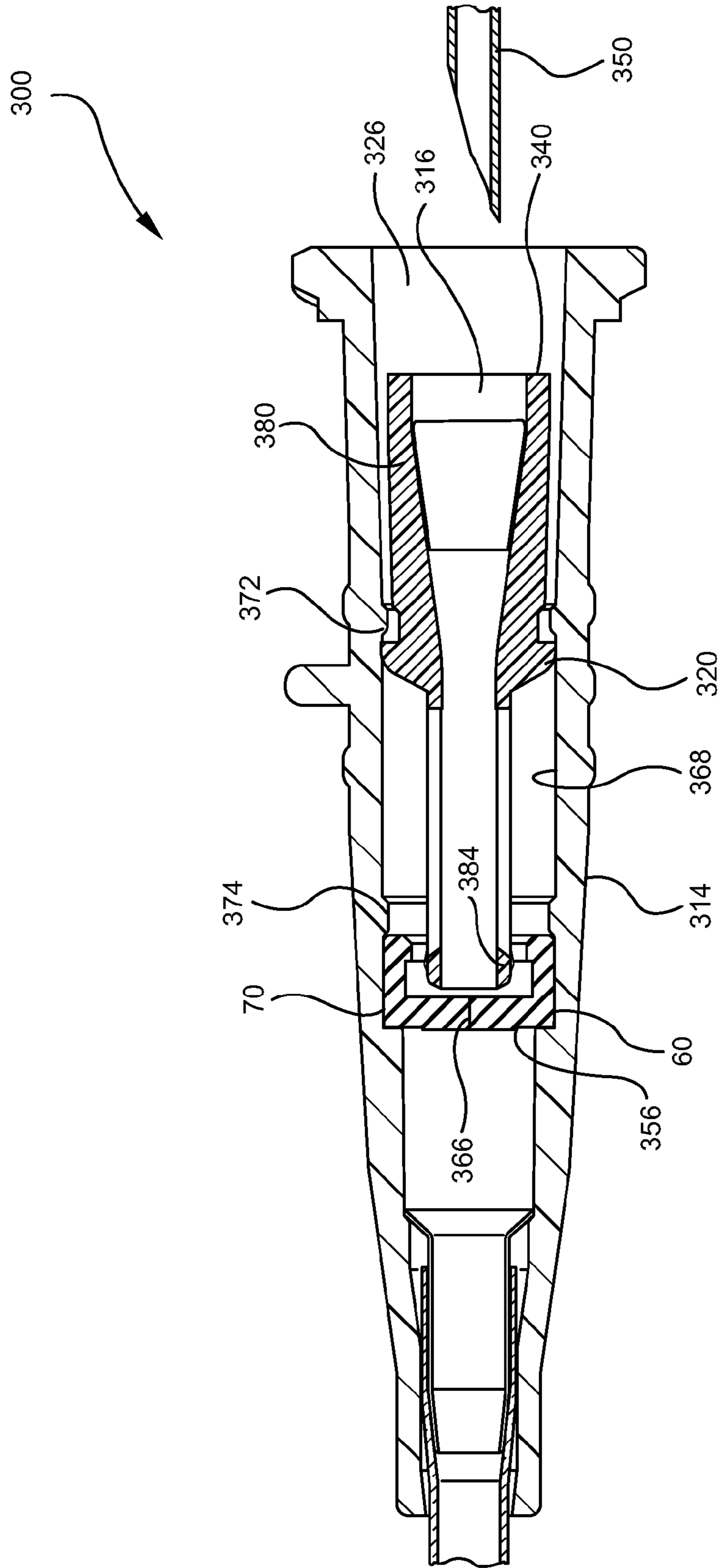

FIG. 11A

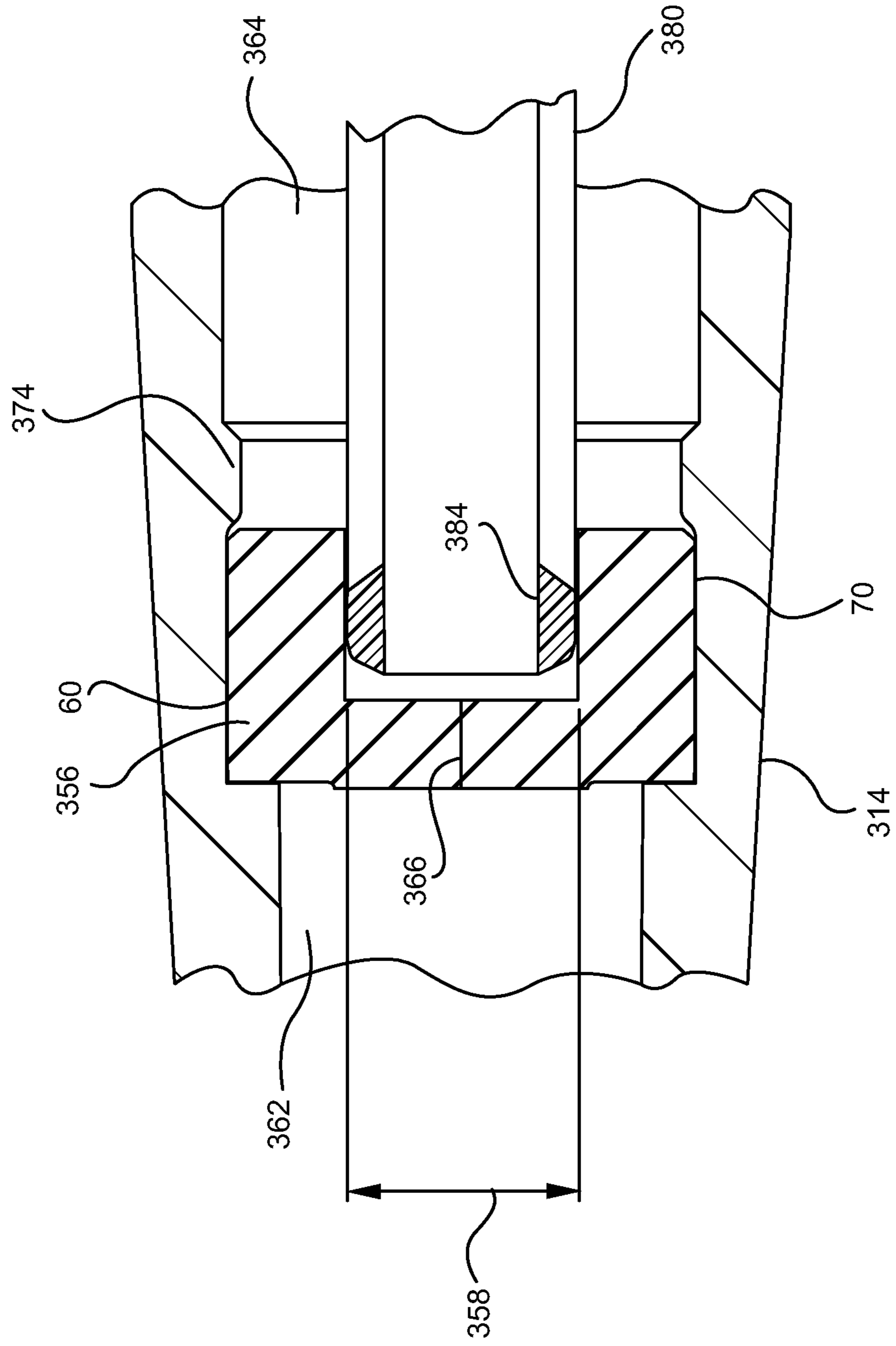

FIG. 11B

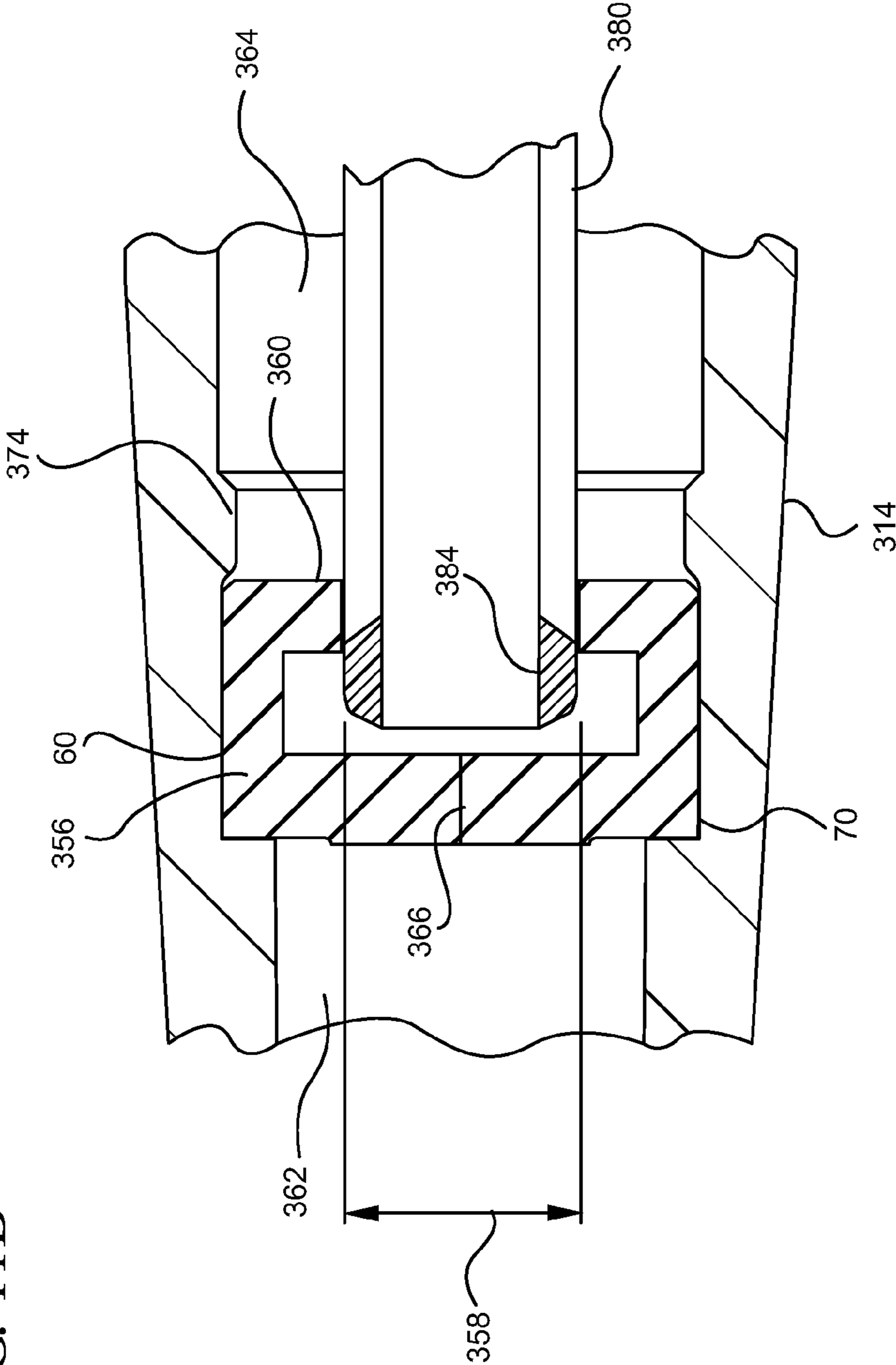

FIG. 11C

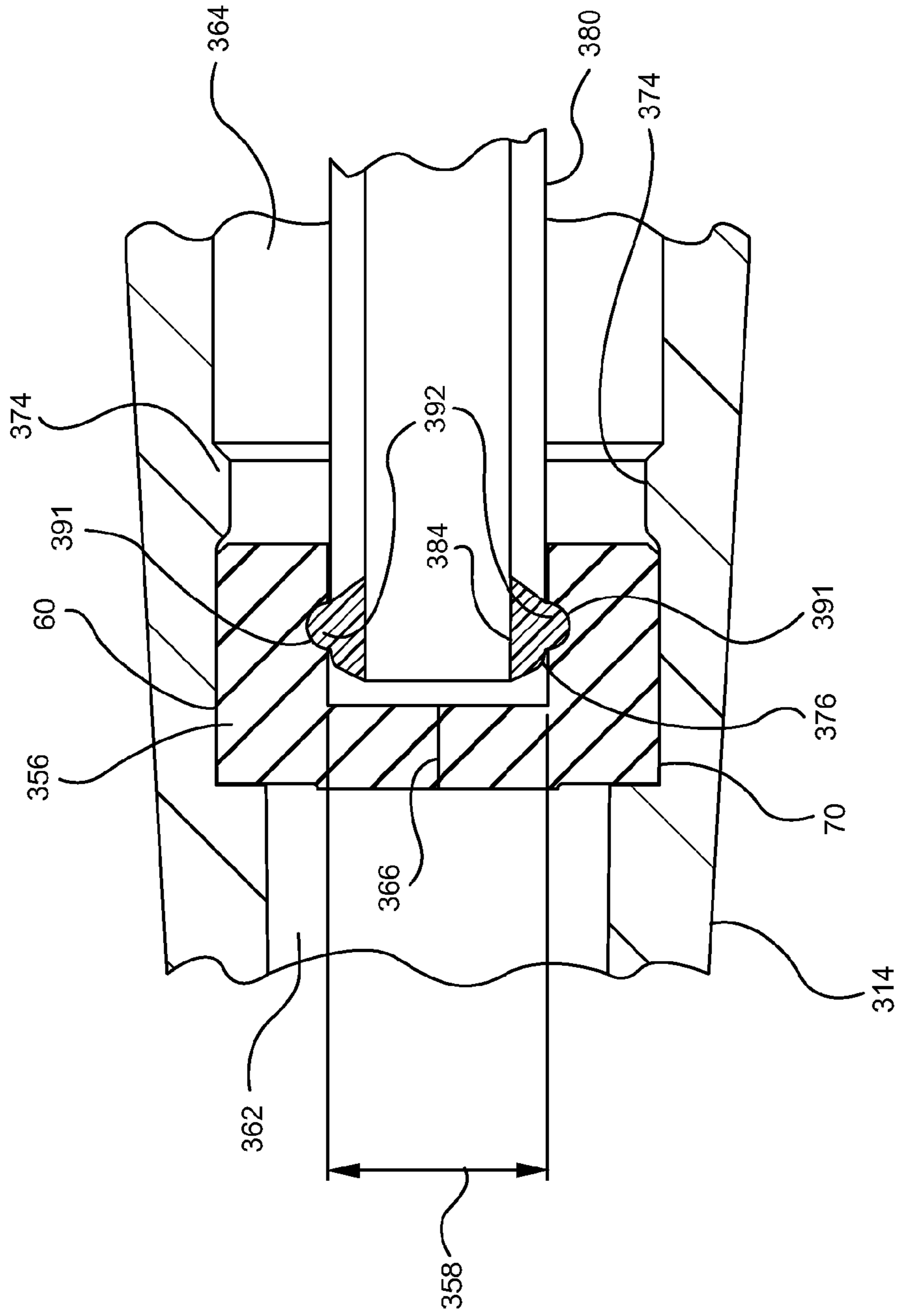

FIG. 11D

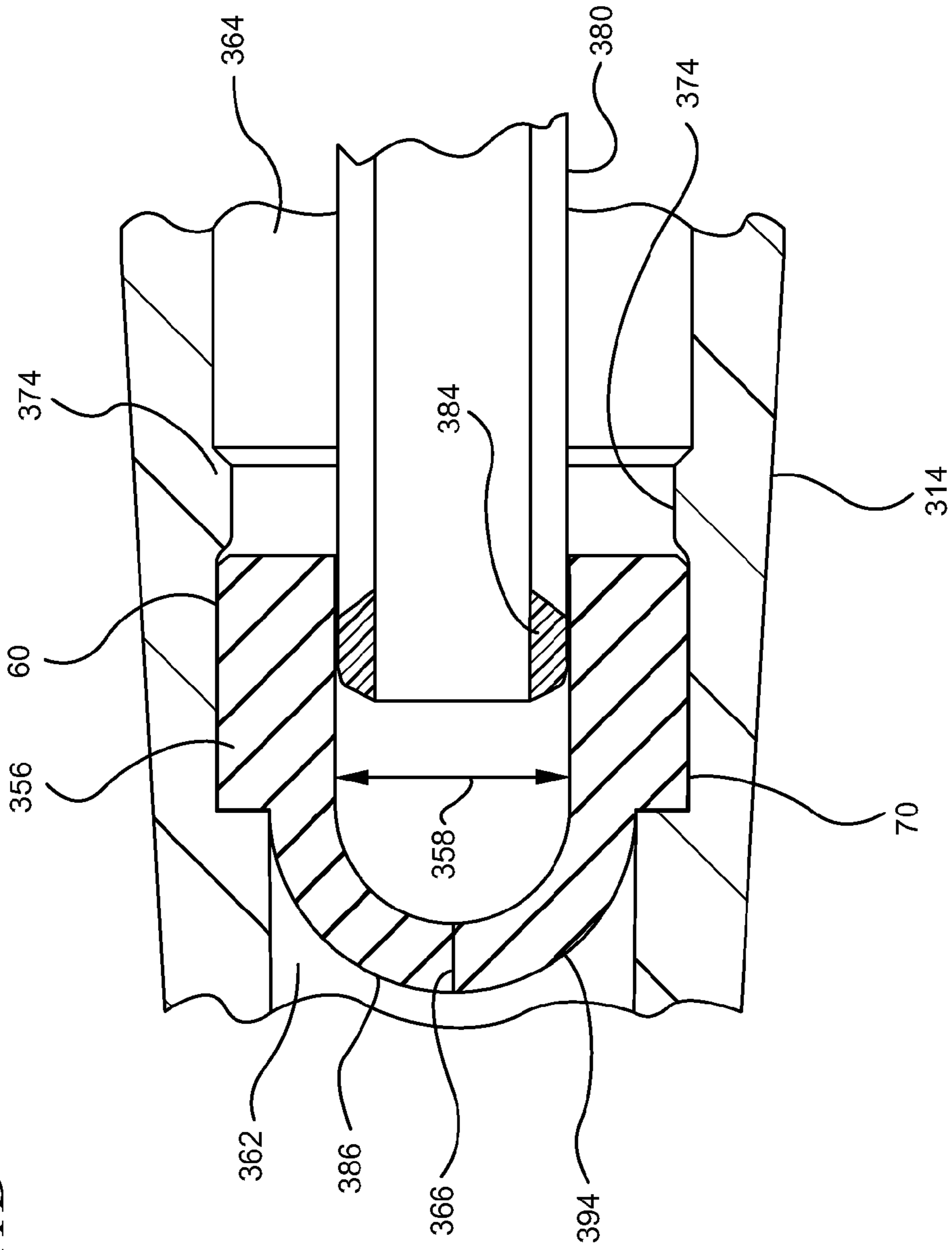
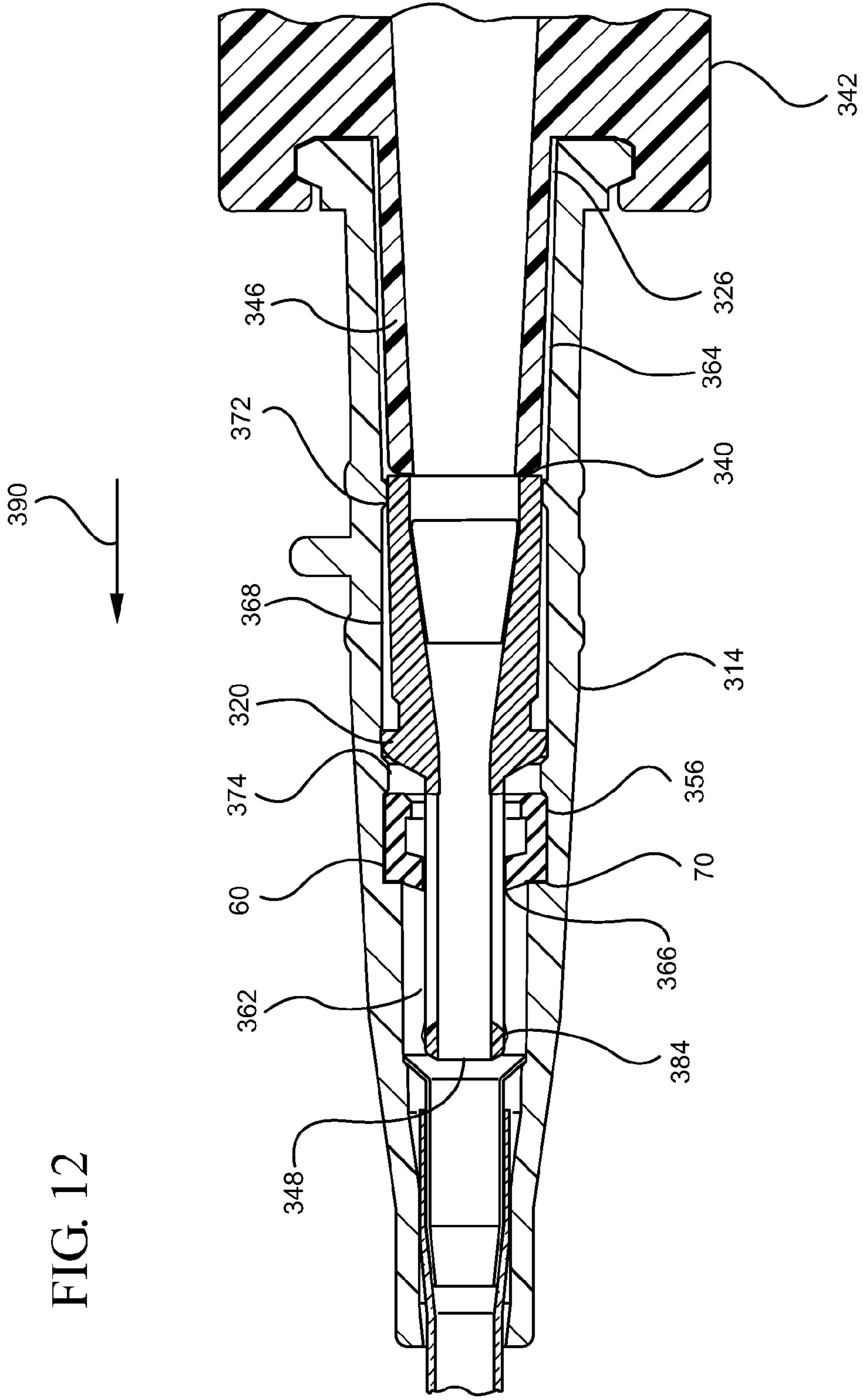

FIG. 12



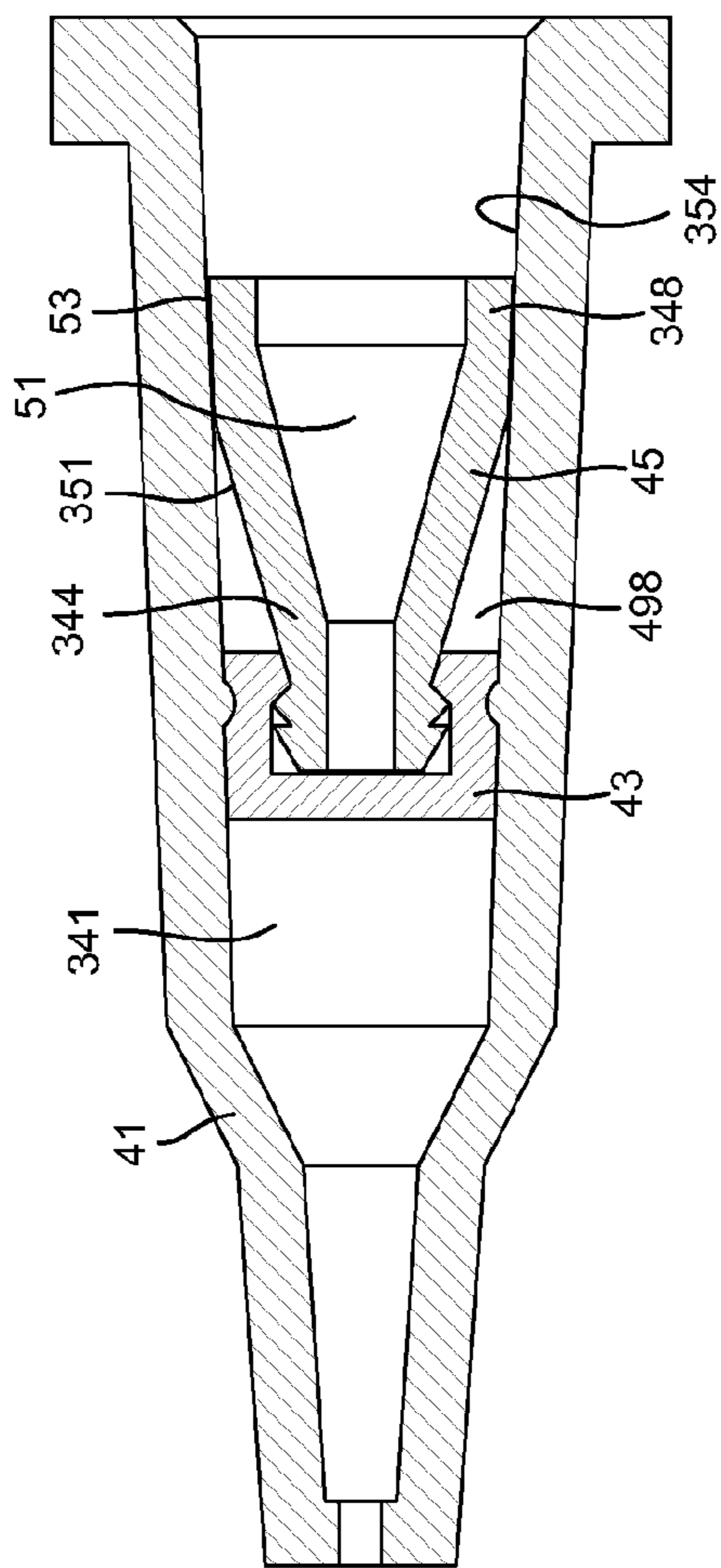

FIG. 13

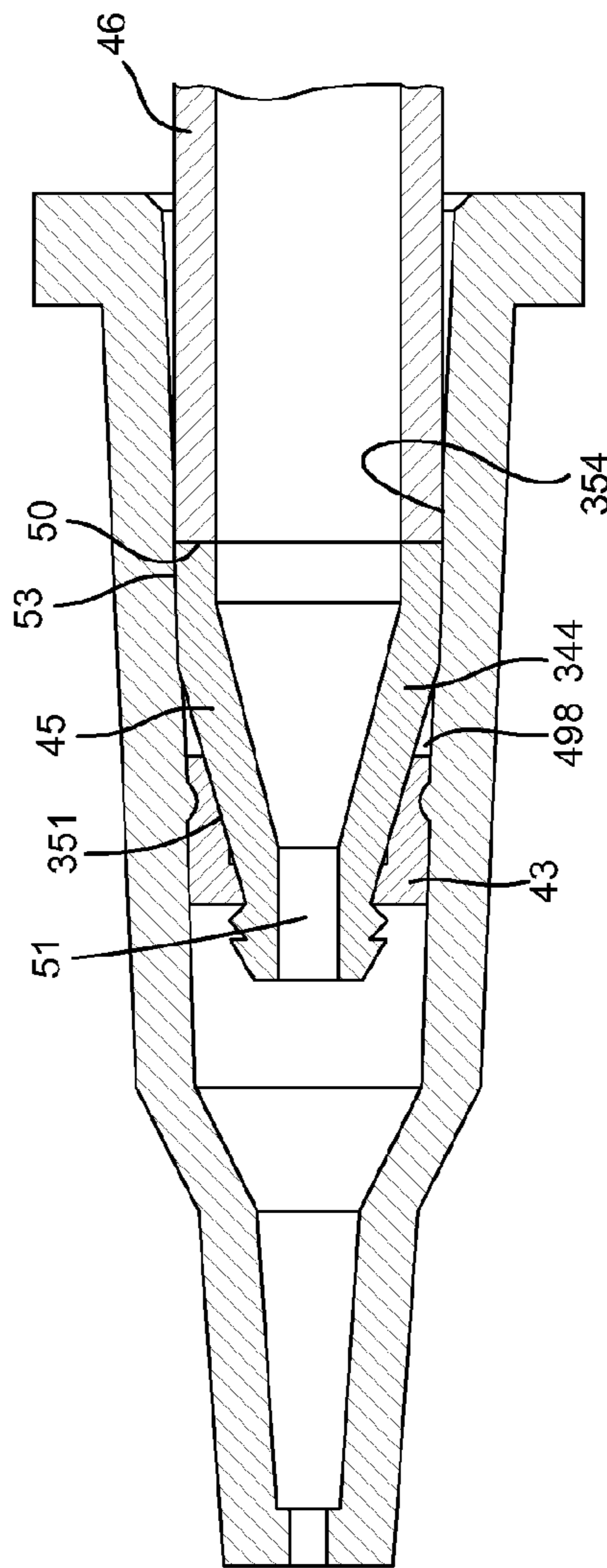

FIG. 14

FIG. 15

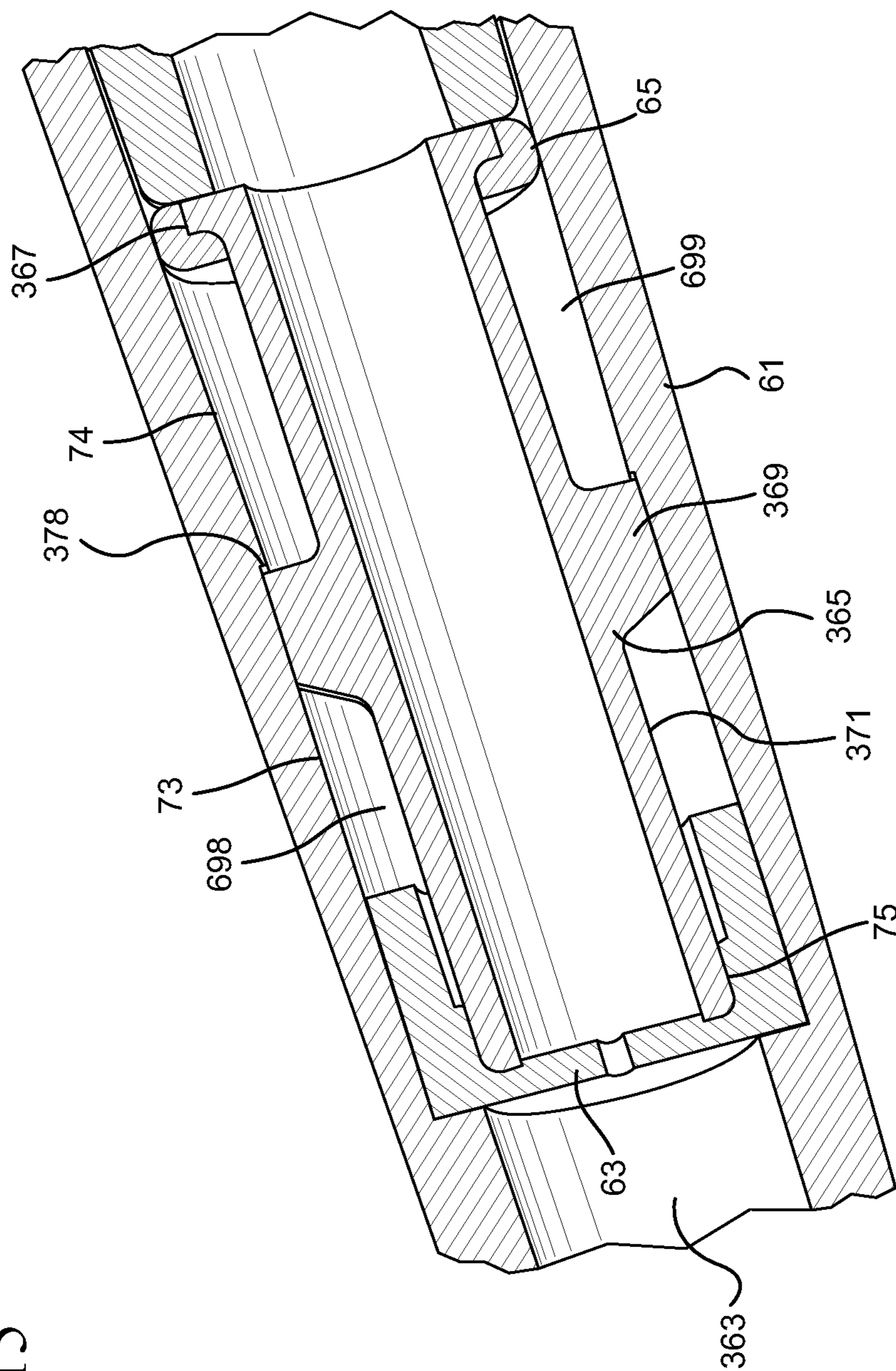

FIG. 16

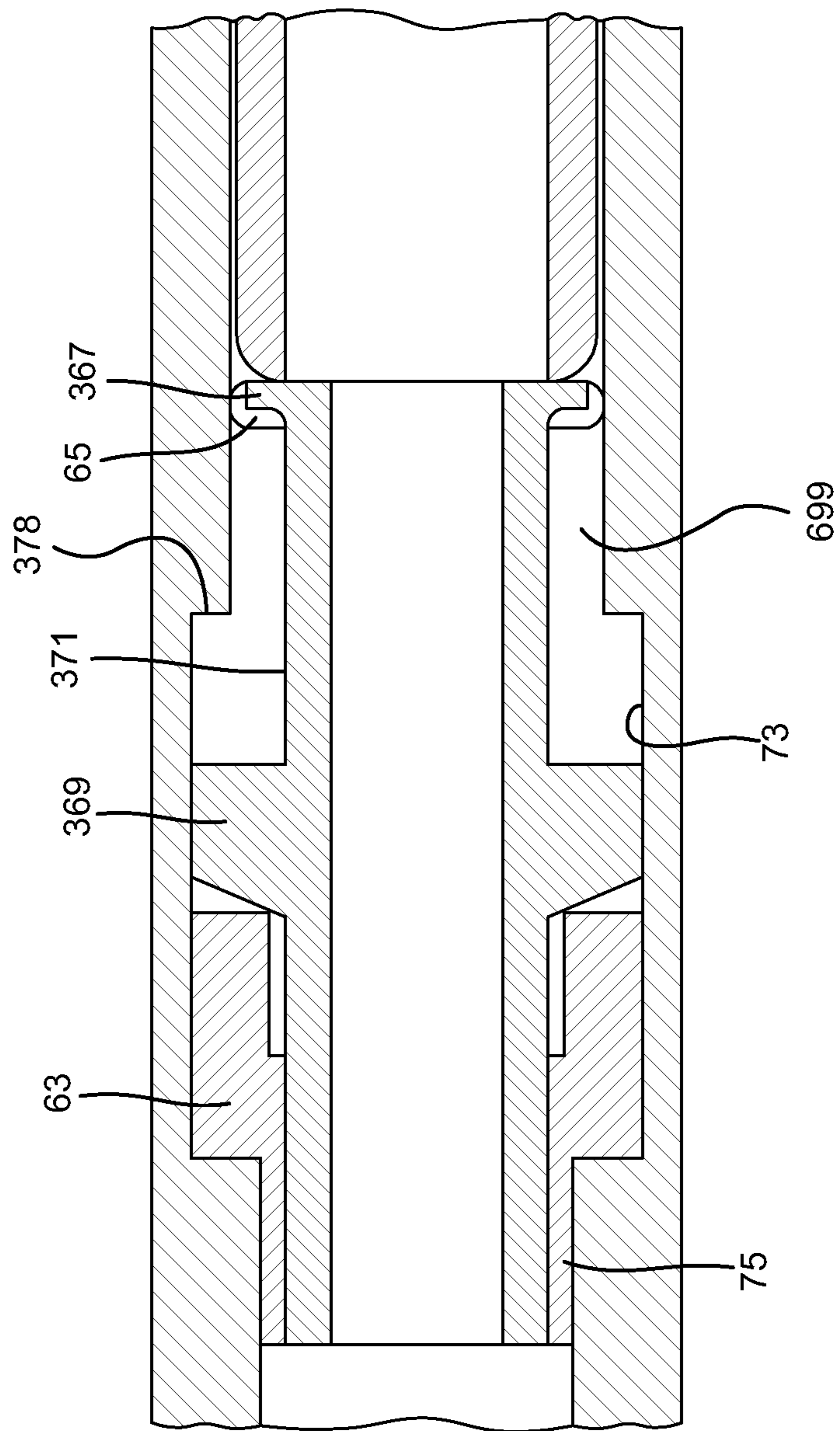

FIG. 17

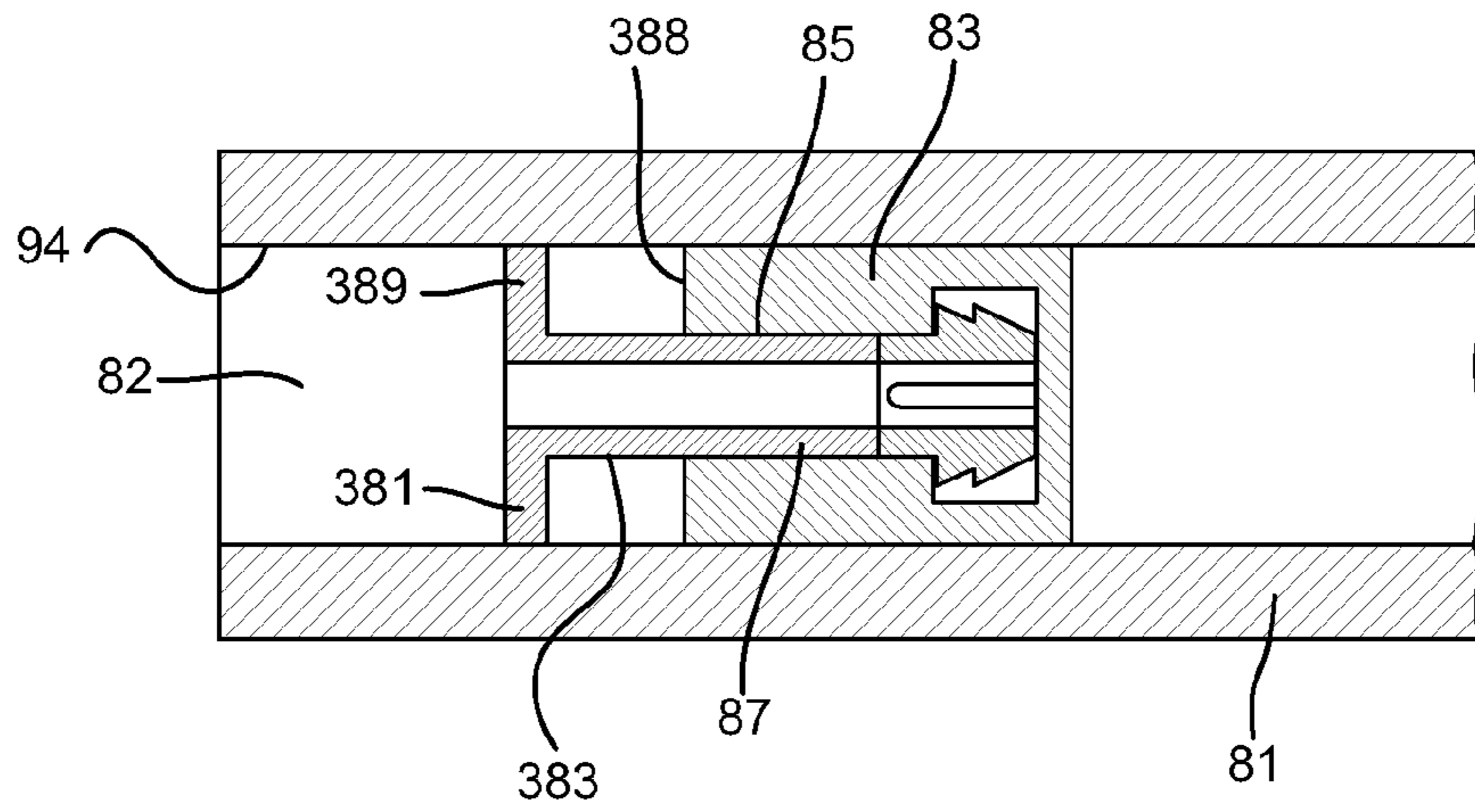

FIG. 18

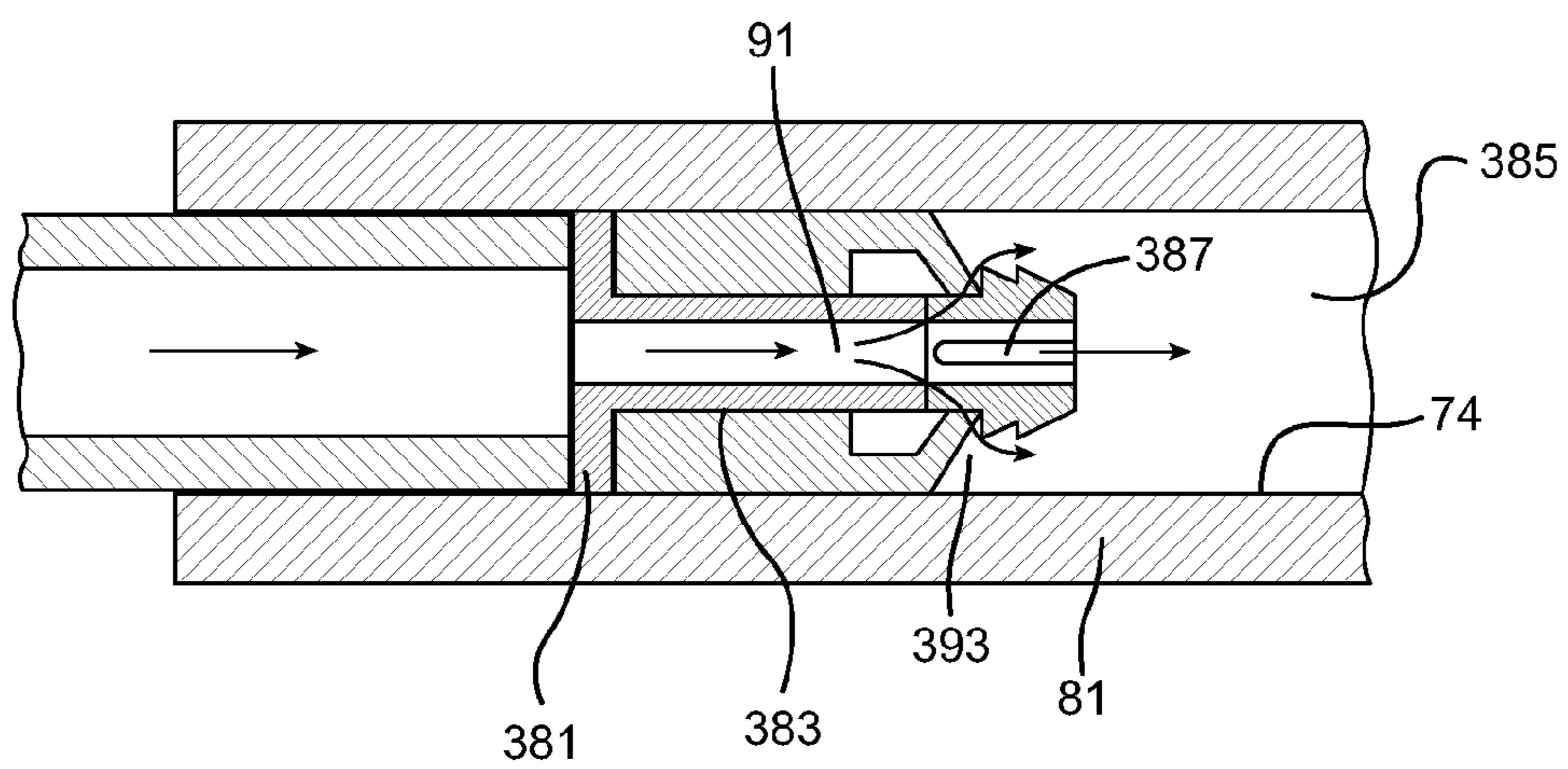

FIG. 19

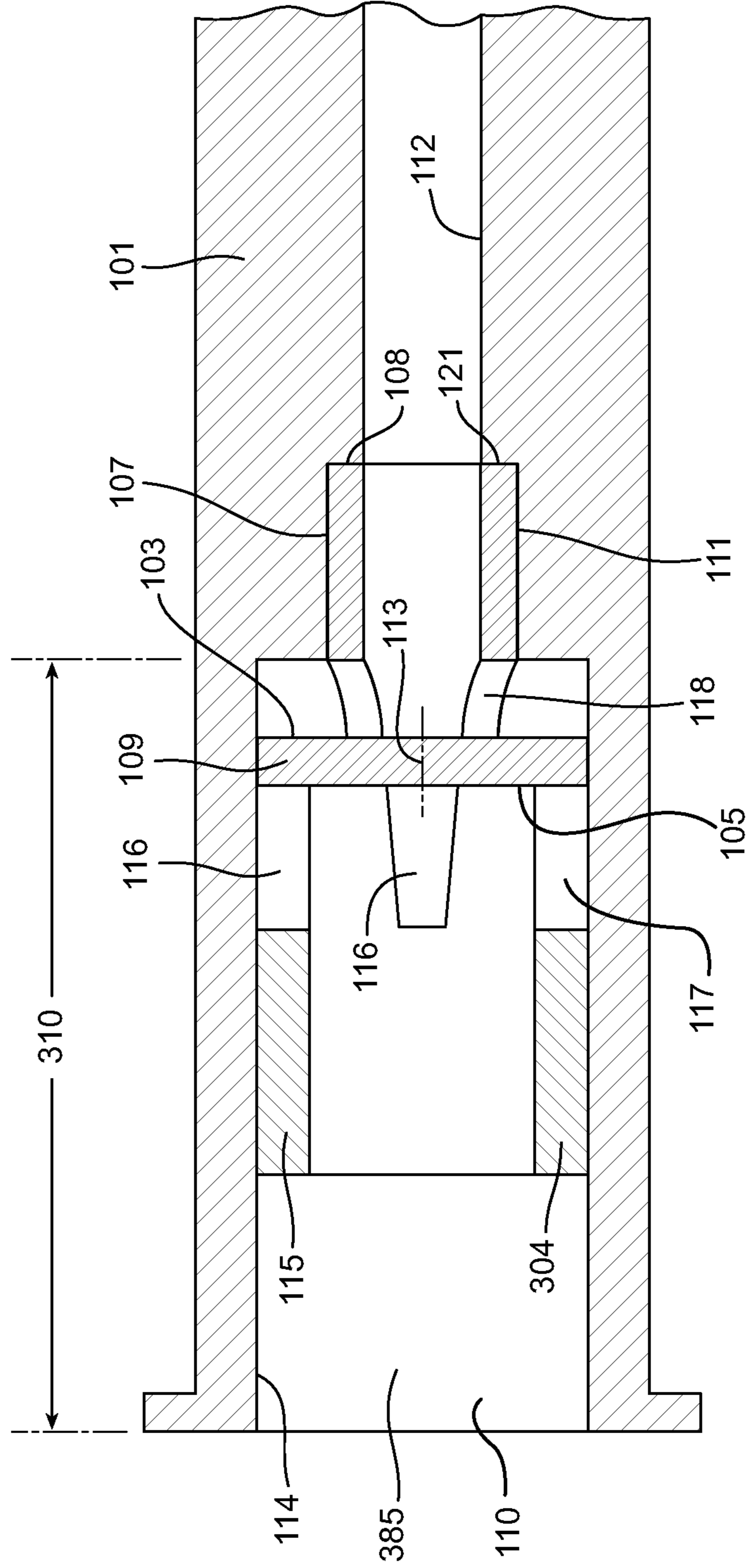
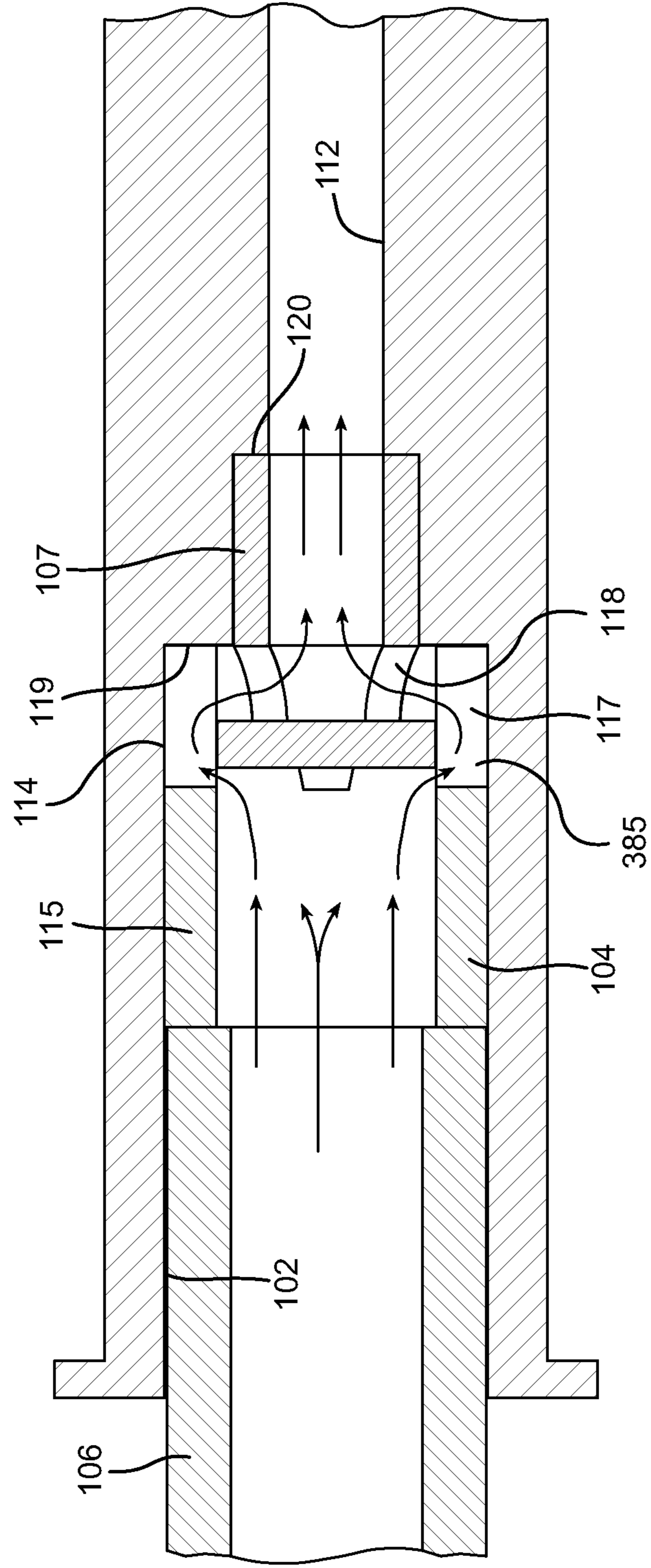

FIG. 20



SYSTEMS AND METHODS FOR PROVIDING A CATHETER ASSEMBLY

Matter enclosed in heavy brackets [] appears in the original patent but forms no part of this reissue specification; matter printed in italics indicates the additions made by reissue; a claim printed with strikethrough indicates that the claim was canceled, disclaimed, or held invalid by a prior post-patent action or proceeding.

RELATED APPLICATIONS

This application is a continuation-in-part of U.S. patent application Ser. No. 12/703,336, filed Feb. 10, 2010, entitled SYSTEMS AND METHODS FOR PROVIDING A FLUSHABLE CATHETER ASSEMBLY, which claims the benefit of U.S. Provisional Application No. 61/151,775, filed Feb. 11, 2009, entitled CATHETER VALVE ASSEMBLY, and which is also a continuation-in-part of U.S. patent application Ser. No. 12/544,625 "SYSTEMS AND METHODS FOR PROVIDING A FLUSHABLE CATHETER ASSEMBLY," filed Aug. 20, 2009. This application claims the benefit of and incorporates by reference each of the above-referenced applications.

BACKGROUND

The current invention relates to infusion devices, specifically to peripheral intravenous (IV) catheters. In particular, the invention relates to a flushable peripheral IV catheter assembly having features to enable selective activation of fluid flow through the catheter assembly.

Catheters are commonly used for a variety of infusion therapies. For example, catheters are used for infusing fluids, such as normal saline solution, various medicaments, and total parenteral nutrition into a patient, withdrawing blood from a patient, as well as monitoring various parameters of the patient's vascular system.

Catheters or needles are typically coupled to a catheter adapter to enable attachment of IV tubing to the catheter. Thus, following placement of the catheter or needle into the vasculature of a patient, the catheter adapter is coupled to a fluid source via a section of IV tubing. In order to verify proper placement of the needle and/or catheter in the blood vessel, the clinician generally confirms that there is "flashback" of blood in a flashback chamber of the catheter assembly.

Once proper placement of the catheter is confirmed, the clinician must then attach the catheter adapter to a section of IV tubing. This process requires the clinician to manually occlude the vein to prevent undesirable exposure to blood. Manual occlusion of the patient vein requires the clinician to awkwardly maintain pressure on the vein of the patient while simultaneously coupling the catheter adapter and the IV tubing.

A common, yet undesirable practice is to permit blood to temporarily and freely flow from the catheter adapter while the clinician locates and couples the IV tubing to the catheter adapter. Another common practice is to attach the catheter adapter to the IV tubing prior to placing the needle or catheter into the vein of the patient. While this method may prevent undesirable exposure to blood, positive pressure within the IV line may also prevent desirable flashback.

Complications associated with infusion therapy include significant morbidity and even mortality. Such complications may be caused by regions of stagnant fluid flow within the

vascular access device or nearby areas of the extravascular system. These are regions in which the flow of fluid is limited or non-existent due to the conformation of the septum or valve mechanism in the extravascular system or the fluid dynamics within that area of the extravascular system. Blood, air bubbles or infused medications may become trapped within these regions of stagnant flow as a result of the limited or non-existent fluid flow. When blood is trapped within the extravascular system bacteria can breed which can lead to infections. When a different medication is infused into the extravascular system, or the extravascular system is exposed to physical trauma, the extravascular system's fluid flow may become altered, releasing trapped air bubbles or residual medications back into the active fluid path of the extravascular system. This release of air bubbles and residual medication into the active fluid path extravascular system may result in significant complications.

Released air bubbles may block fluid flow through the extravascular system and prevent its proper functioning. More seriously, released air bubbles may enter the vascular system of the patient and block blood flow, causing tissue damage and even stroke. In addition, residual medications may interact with presently infused medications to cause precipitates within the extravascular system and prevent its proper functioning. Furthermore, residual medications may enter the vascular system of the patient and cause unintended and/or undesired effects.

Accordingly, there is a need in the art for a catheter assembly that permits controlled, desirable flashback without the risk of encountering undesirable exposure to blood. Furthermore, there is a need in the art to provide a valve mechanism in a catheter assembly that eliminates, prevents, or limits regions of stagnant flow within vascular access devices and extravascular system to provide better flush properties. Such a catheter assembly is disclosed herein.

SUMMARY

In order to overcome the limitations discussed above, the present invention relates to a flushable peripheral IV catheter assembly having features to enable selective activation of fluid flow through the catheter assembly. The catheter assembly of the present invention generally includes a catheter coupled to a catheter adapter. The catheter generally includes a metallic material, such as titanium, surgical steel or an alloy as is commonly known in the art. In some embodiments, a polymeric catheter may be used in combination with a metallic introducer needle, as is commonly known and used in the art.

In some embodiments of the present invention, a septum is positioned within a lumen of the catheter assembly to prevent or limit flow of a fluid through the catheter adapter. The septum generally includes a flexible or semi-flexible material that is compatible with exposure to blood, medicaments, and other fluids commonly encountered during infusion procedures. In some embodiments, a groove is provided on an inner surface of the catheter adapter, wherein the septum is seated within the groove. As such, the position of the septum within the catheter adapter is maintained.

In some implementations of the present invention, a closed or partially closed pathway, such as a slit or small hole is further provided in a barrier surface of the septum. The pathway permits fluid to bypass the septum and flow through the catheter adapter. In some embodiments, the pathway is a slit that is closed prior to being opened or activated by a probe or septum activator positioned within the lumen of the catheter adapter. Prior to being opened or activated, the slit prevents

passage of fluid through the catheter adapter. Thus, in some embodiments a plurality of air vent channels are interposed between the septum and the groove to permit air flow through the catheter adapter prior to the slit being opened. The air vents prevent buildup of positive pressure within the catheter adapter thereby permitting flashback of blood into the catheter and a forward chamber of the catheter adapter.

The septum activator generally includes a plastic or metallic tubular body having a probing end and a contact end. The probing end is positioned adjacent to the pathway of the septum, and the contact end is positioned adjacent to a proximal opening of the catheter adapter. The probing end of the septum activator is advanced through the pathway of the septum when a probe is inserted into the proximal opening of the catheter adapter. As the probe contacts the contact surface of the septum activator, the septum activator is advanced in a distal direction through the catheter adapter whereupon the probing end of the septum activator opens the pathway through the septum. Once opened, free flow of fluid is enabled through the catheter assembly.

In some aspects, a Parylene coating is disposed on the surface of the septum, include within the surfaces of the slit of the septum. The thickness of the coating is between 0.00005 to 0.0005 millimeters in order to enable the septum to properly open and close. In other embodiments, the thickness of the coating is between 0.0001 to 0.0002 millimeters. The septum can comprise a silicone rubber material and have a tri-slit configuration (three slits meeting at a center point, to form a single opening.)

Finally, the presence of the septum activator within the lumen of the catheter adapter may result in aberrant fluid flow leading to undesirable stagnation and coagulation of fluids within the catheter assembly. Thus, in some embodiments of the present invention the septum activator further includes various flow deflectors and/or flow diversion channels to maintain proper fluid flow within the catheter adapter.

BRIEF DESCRIPTION OF THE SEVERAL VIEWS OF THE DRAWINGS

In order that the manner in which the above-recited and other features and advantages of the invention are obtained will be readily understood, a more particular description of the invention briefly described above will be rendered by reference to specific embodiments thereof which are illustrated in the appended drawings. These drawings depict only typical embodiments of the invention and are not therefore to be considered to limit the scope of the invention.

FIG. 1 is a cross-sectioned view of an indwelling catheter having a PRIOR ART flow control valve mechanism.

FIG. 2 is a cross-sectioned view of the PRIOR ART indwelling catheter of FIG. 1 following removal an introducer needle.

FIG. 3 is a cross-sectioned view of the PRIOR ART indwelling catheter of FIGS. 1 and 2 following insertion of a connector from a vascular access device.

FIG. 4 is a perspective view of an embodiment of a catheter assembly in accordance with the present invention.

FIG. 5A is an exploded cross-sectioned view of a catheter assembly in accordance with the present invention.

FIG. 5B is a perspective view of an embodiment of a septum in accordance with the present invention.

FIG. 6A is a cross-sectioned view of an interior lumen of a catheter adapter demonstrating fluid flow without the presence of a septum activator in accordance with a representative embodiment of the present invention.

FIG. 6B is a perspective view of an embodiment of a septum activator in accordance with the present invention.

FIG. 6C is a side view of an embodiment of a septum activator disposed in an inner lumen of a catheter adapter in accordance with the present invention, following activation.

FIG. 6D is a side view of an embodiment of a septum activator disposed in an inner lumen of a catheter adapter in accordance with the present invention, demonstrating fluid flow through the catheter adapter.

FIG. 7 is a cross-sectioned view of an assembled catheter assembly in accordance with the present invention, prior to activation.

FIG. 8 is a cross-sectioned view of an assembled catheter assembly in accordance with the present invention, following activation.

FIG. 9 is a cross-sectioned view of an assembled over-the-needle catheter assembly in accordance with the present invention, prior to activation.

FIG. 10 is a cross-sectioned view of an assembled over-the-needle catheter assembly in accordance with a representative embodiment of the present invention, following removal of the introducer needle.

FIGS. 11A through 11D are cross-sectioned views of septum having various features and configuration in accordance with representative embodiments of the present invention.

FIG. 12 is a cross-sectioned view of an assembled over-the-needle catheter assembly in accordance with a representative embodiment of the present invention, following activation.

FIG. 13 is a cross-sectioned view of a catheter body having a flow control valve mechanism and a septum activator in accordance with a representative embodiment of the present invention, prior to activation.

FIG. 14 is a cross-sectioned view of a catheter body having a flow control valve mechanism and a septum activator in accordance with a representative embodiment of the present invention, following activation.

FIG. 15 is a cross-sectioned view of a catheter body having a flow control valve mechanism and septum activator in accordance with a representative embodiment of the present invention, prior to activation.

FIG. 16 is a cross-sectioned view of a catheter body having a flow control valve mechanism according to the representative embodiment shown in FIG. 15, following activation.

FIG. 17 is a cross-sectioned view of a catheter body having a flow control valve mechanism and septum activator in accordance with a representative embodiment of the present invention, prior to activation.

FIG. 18 is a cross-sectioned view of a catheter body having a flow control valve mechanism according to the representative embodiment shown in FIG. 17, following activation.

FIG. 19 is a cross-sectioned view of a catheter body having a flow control valve mechanism and septum activator in accordance with a representative embodiment of the present invention, prior to activation.

FIG. 20 is a cross-sectioned view of a catheter body having a flow control valve mechanism according to the representative embodiment shown in FIG. 19, following activation.

DETAILED DESCRIPTION OF THE INVENTION

The presently preferred embodiment of the present invention will be best understood by reference to the drawings, wherein like reference numbers indicate identical or functionally similar elements. It will be readily understood that the components of the present invention, as generally described and illustrated in the figures herein, could be

5

arranged and designed in a wide variety of different configurations. Thus, the following more detailed description, as represented in the figures, is not intended to limit the scope of the invention as claimed, but is merely representative of presently preferred embodiments of the invention.

The term "proximal" is used to denote a portion of a device which, during normal use, is nearest the user and furthest from the patient. The term "distal" is used to denote a portion of a device which, during normal use, is farthest away from the user wielding the device and closest to the patient. The term "activation" of valve mechanism or septum is used to denote the action of opening or closing of such valve.

An example of a prior art extravascular system is disclosed in U.S. Pat. No. 7,008,404 and shown in FIGS. 1 to 3. An indwelling catheter has, as shown in FIG. 1, a hollow catheter body 1, a catheter 2 fitted into a holder 1b provided at a distal end of the catheter body 1, a septum 3 fitted inside the catheter body 1, and a hollow pusher 4 slidably fitted inside the catheter body 1. The catheter tube 2, septum 3, and the pusher 4 are coaxially aligned in this order.

The catheter body 1 has a tubular shape. An inner surface 1a is tapered toward the distal end, with a gradually reduced diameter. The catheter body 1 is preferably of a transparent or semi-transparent material so as to show the interior, enabling checking of movement inside. Suitable materials for catheter body 1 include, but are not limited to, thermoplastic polymeric resins such as polycarbonate, polystyrene, polypropylene and the like.

The catheter 2 is press-fitted into the tube holder 1b which communicates at its proximal end with the inside of the catheter body 1. It is preferred that a lubricating coating is provided to the entirety or part of the catheter 2 so as to reduce resistance caused by insertion through skin or into a blood vessel. Suitable materials for catheter 2 include, but are not limited to, thermoplastic resins such as fluorinated ethylene propylene (FEP), polytetrafluoroethylene (PTFE), polyurethane and the like. Preferably, catheter 2 is formed from a thermoplastic hydrophilic polyurethane that softens with exposure to physiological conditions present in the patient's body.

The septum 3 is of a generally tubular shape having a proximal end 8 and a membrane section 9 having a planar flat surface 10 located at the distal end 11. Typically, septum 3 further includes a single needle slit 3a or valve aperture located about the centre of membrane section 9, extending through membrane section 9, to facilitate penetration of septum 3 by introducer needle 5. The opposing slit surfaces of the needle slit 3a are designed to closely conform to the shape of introducer needle 5 during storage and prevent an outflow of fluid during and following removal of the introducer needle 5, then to seal upon removal of the introducer needle 5. With the pusher 4 inserted therethrough, slit 3a expands forward in the distal direction and opens, providing fluid communication between the catheter 2 and the rear of the catheter body 1. An annular protrusion 3b is provided on the inner surface of a rear opening of the septum 3, to engage shoulder 4c at the distal end of the pusher 4 so as to limit the movement of pusher 4 in the proximal direction and prevent the dislocation of the pusher 4 from septum 3. A plurality of gaps 3c are defined between an outer periphery of the septum 3 and the inner surface 1a of the catheter body 1. Distal and proximal spaces divided by the septum 3 communicate with each other through the gaps 3c. Thus the septum 3 slides smoothly with air passing through the gaps 3c.

The pusher 4 is typically made from a rigid thermoplastic material or a like material, and has a lumen extending there-through. The pusher 4 has a tubular portion 4a, a conical

6

flange 4b connected to the rear proximal end of the tubular portion 4a, and a shoulder 4c protruding from an outer periphery of the tubular portion 4a. Thus an annular shaped interstitial space is created between tubular portion 4a and the inner surface 1a of the catheter body 1. The distal front end of the tubular portion 4a is chamfered to facilitate its penetration into slit 3a of the septum 3, and is slidably supported by the annular protrusion 3b of the septum 3. The conical flange 4b has a conical inner surface so as to facilitate insertion of the needle 5 thereinto. The peripheral surface of the flange 4b contacts the inner surface 1a of the catheter body 1 and serves to provide stability to the pusher 4 and maintain the coaxial position with respect to the catheter 2. However the peripheral surface of the flange 4b does not form a fluid seal with inner surface 1a.

The indwelling catheter is prepared for use in such a state as shown in FIG. 1 with the front end of the needle 5 protruding from the front end of the catheter 2. In this state, the needle 5 penetrates through the septum 3, providing water-tight connection therebetween, and thereby preventing leakage of blood.

The indwelling catheter in this state is inserted into the body of a patient. Then, as shown in FIG. 2, the needle 5 is removed with the tube 2 retained in the body of the patient. Septum 3 maintains a fluid seal upon removal of needle 5, being retained catheter body 1 by an annular protrusion 1e. Pusher 4 is retained in a proximal position by the interaction of annular protrusion 3b and shoulder 4c.

A connector 6 (e.g. a luer connector) of a vascular access device is then inserted from the proximal end of the catheter body 1. When pressed into the catheter body 1, the connector 6 pushes at its distal end the pusher 4. The pusher 4 thus slides forward in distal direction to press at its distal end slit 3a of the septum 3 open thereby activating the flow control valve to the open position. The septum 3 is then pressed against the inner surface of a tapered cavity 1c of the catheter body 1 which stops the forward movement of pusher 4 at a distal position as shown in FIG. 3, thus providing communication between the catheter 2 and the vascular access device. The tapered inner surface 1a of the catheter body 1 allows for smooth insertion of the connector 6 and tight contact between an outer surface 6a of the connector 6 and the inner surface 1a through press fitting in order to prevent fluid leaking out of the proximal end of catheter body 1.

However, it should be noted that this valve mechanism has small interstitial spaces/areas within the catheter body 1 into which fluids can flow during use, which give rise to areas of low or no fluid flow. For example, in use, fluid can flow between the peripheral surface of the flange 4b and the inner surface 1a of catheter body 1 and into the interstitial space 98 between the outer periphery of tubular portion 4a and the inner surface 1a. In addition, fluid can flow into interstitial space 99 which is gap 3c between the outer periphery of septum 3 and the inner surface 1a of the catheter body 1. The low or no fluid flow that exists in spaces/areas 98 and 99 makes it very difficult to subsequently flush out any blood, medicament or air bubbles which may flow into these areas during use of the catheter.

Referring now to FIG. 4, a catheter assembly 101 is illustrated. The catheter assembly 101 generally includes a catheter 12 coupled to a distal end 32 of a catheter adapter 14. The catheter 12 and the catheter adapter 14 are integrally coupled such that an internal lumen 16 of the catheter adapter 14 is in fluid communication with a lumen 18 of the catheter 12. The catheter 12 generally comprises a biocompatible material having sufficient rigidity to withstand pressures associated with insertion of the catheter into a patient. In some embodi-

ments, the catheter **12** comprises a metallic material, such as titanium, stainless steel, nickel, molybdenum, surgical steel, and alloys thereof. In other embodiments, the catheter **12** comprises a rigid, polymer material, such as vinyl. A tip portion **20** of the catheter is generally configured to include a beveled cutting surface **48**. The beveled cutting surface **48** is utilized to provide an opening in a patient to permit insertion of the catheter **12** into the vascular system of the patient.

The features of the catheter assembly may be incorporated for use with an over-the-needle catheter assembly. For example, a flexible or semi-flexible polymer catheter may be used in combination with a rigid introducer needle to enable insertion of the catheter into a patient. Surgically implanted catheters may also be used.

Once inserted into a patient, the catheter **12** and catheter adapter **14** provide a fluid conduit to facilitate delivery of a fluid to and/or retrieval of a fluid from a patient, as required by a desired infusion procedure. Thus, in some embodiments the material of the catheter **12** and the catheter adapter **14** are selected to be compatible with bio-fluids and medicaments commonly used in infusion procedures. Additionally, in some embodiments a portion of the catheter **12** and/or catheter adapter **14** is configured for use in conjunction with a section of intravenous tubing **40** to further facilitate delivery of a fluid to or removal of a fluid from a patient.

In some embodiments, a proximal end **22** of the catheter adapter **14** includes a flange **28**. The flange **28** provides a positive surface which may be configured to enable coupling of an intravenous tubing or patient conduit **40** to the catheter assembly **101**. In some embodiments, the flange **28** includes a set of threads **30**. The threads **30** are generally provided and configured to compatibly receive a complementary set of threads **44** comprising a portion of a male luer or conduit coupler **42**. The conduit coupler **42** is generally coupled to an end portion of the patient conduit **40** in a fluid-tight manner. In some embodiments, an inner portion of the conduit coupler **42** is extended outwardly to provide a probe surface **46**.

The probe surface **46** is generally configured to compatibly insert within a proximal end **22** of the catheter adapter **14**. Following insertion of the probe **46** into the proximal end **22** of the catheter adapter **14**, the conduit coupler **42** is rotated to interlock the coupler **42** and the flange **28** (via the sets of threads **30** and **44**). During the process of interlocking the coupler **42** and the flange **28**, the probe **46** is advanced into the lumen **16** of the catheter adapter **14** to an inserted position (as shown in FIG. **8**). The inserted position of the probe surface **46** activates the catheter assembly **101** to enable flow of fluid through the catheter **12** and catheter adapter **14**. Once the conduit coupler **42** and the catheter adapter **14** are attached, a fluid may be delivered to a patient via the patient conduit **40** and the inserted catheter **12**.

Referring now to FIG. **5A**, an exploded, cross-sectional view of a catheter assembly **101** is shown. In some embodiments, the catheter adapter **14** includes various design features and components to control and/or limit flow of fluid through the catheter assembly **101**. For example, in some embodiments of the present invention a septum **50** is positioned within the inner lumen **16** of the catheter adapter **14**. The septum **50** generally comprises a flexible, or semi-flexible polymer plug having an outer diameter that is configured to compatibly seat within a groove or channel **60** formed on an inner surface **24** of the catheter adapter **14**. In some embodiments, the septum **50** is barrel shaped having a barrier surface **52** comprising a distal end of the septum **50** and further having an opening **54** comprising a proximal end of the septum **50**. When positioned within the channel **60**, the barrier surface **52** of the septum **50** divides the inner lumen **16** of the

catheter adapter **14** into a forward fluid chamber **62** and a rearward fluid chamber **64**. Thus, the presence of the septum **50** controls or limits passage of fluid between the forward and rearward fluid chambers **62** and **64**. Specifically, a chosen configuration of the barrier surface **52** of the septum **50** largely determines the ability of a fluid to flow through the inner lumen **16** of the catheter adapter **14**.

For example, in some embodiments the barrier surface **52** of the septum **50** is configured to include a slit **56**. The slit **56** is configured to provide selective access or flow of a fluid through the barrier surface **52**. In some embodiments, slit **56** is configured to remain in a closed, fluid-tight position until activated or opened by advancing a septum activator **80** through the slit **56** in a distal direction **390**. In some embodiments, the barrier surface **52** comprises one slit **56**. In other embodiments, the barrier surface **52** is modified to include multiple slits **56** and **66**, as shown in FIG. **8**. For example, the septum **50** can include a tri-slit configuration, wherein three slits meeting at a center point, to form a single opening. In some embodiments, the septum **50** comprises a silicone rubber material. In some embodiments, the septum **50** consists essentially of a silicone rubber material.

In some aspects, a Parylene coating is disposed on the surface of the septum **50**, include within the surfaces of the slit **56** of the septum **50**. Parylene is a chemically resistant coating with good barrier properties for inorganic and organic fluids, strong acids, caustic solutions, gases and water vapors. In some embodiments, a Parylene coating is applied to the outer surface of the septum **50** via vapor deposition. A Parylene coating is a harder material than the substrate material of the septum, such as silicon rubber or a like material. When the septum **50** is coated with the typical industry Parylene thickness, which is greater than 1 micrometer, the edges of the slit **50** become very stiff. The typical coating thickness for Parylene in the industry is in the range of 0.001 to over 0.025 millimeters. The harder edge of the slit leaf could indent the soft face of the slit thus prevent the slit from closing properly after the withdrawal of the needle. This increased resistance to close makes the seal not as effective. Additionally, when the septum **50** is coated with an industry-standard, thick layer of Parylene, the friction coefficient between the septum **50** and the inner surface **24** of the catheter adapter **14** is reduced, thus reduce the force required to remove the septum **50** from within the catheter adapter **14**. On the other hand, when the septum is not coated with Parylene, the silicone septum is tacky and difficult to feed in the automated process.

Accordingly, in some configurations, the thickness of the coating can be between 0.00005 to 0.0005 millimeters. In other embodiments, the thickness of the coating is between 0.0001 to 0.0035 millimeters. In other embodiments, the thickness of the coating is between 0.0001 to 0.0002 millimeters. With this type of thin layer of Parylene coating, the slit **56** will close easily after the needle withdraws. In addition, the reduced thickness of Parylene coating will provide additional friction force between the outer surface of the septum **50** and the inner surface **24** of the catheter adapter **14**, increasing the retention force of the septum **50**.

For some infusion therapy techniques, it may be desirable to permit a controlled flow of fluid through the septum **50** prior to activating the septum **50** with the septum activator **80**. Thus, in some embodiments the slit **56** further comprises a leak orifice **58**. The leak orifice **58** is positioned in the barrier surface **52** and comprises an opening diameter calculated to permit controlled flow of liquid or air between the forward and rearward chambers **62** and **64**. In some embodiments, the barrier surface **52** is modified to include a single leak orifice **58**. In other embodiments, the barrier surface **52** is configured

to include multiple leak orifices. Still, in other embodiments the barrier surface 52 does not include a slit 56, but rather includes at least one leak orifice 58. For these embodiments, the septum 50 generally comprises an elastic material such that when the septum activator 80 is advanced in a distal direction 390, a leading edge 92 of the septum activator 80 contacts the barrier surface 52 and stretches the leak orifice 58 to provide a larger orifice thereby permitting increased flow of air and/or fluid through the catheter adapter 14.

The groove or channel 60 into which the septum is seated comprises a recessed portion of the inner surface 24 of the catheter adapter 14. The outer diameter of the septum 50 is generally configured to compatibly and securely seat within the channel 60. For example, in some embodiments the outer diameter of the septum 50 is selected to be both slightly smaller than the diameter of the channel 60 and slightly larger than the diameter of the inner lumen 16. As such, the septum 50 is retained within the channel 60 during use of the catheter assembly 101.

For some infusion therapy techniques, air flow between the forward and rearward chambers 62 and 64 may be desirable. For example, for those embodiments comprising a septum 50 having a fluid-tight slit 56, passage of air from the forward chamber 62 to the rearward chamber 64 is prohibited prior to opening or activating the septum 50 via the septum activator 80, as previously discussed. Thus, when the catheter 12 of the catheter assembly 101 is inserted into the vascular system of a patient, a positive pressure develops within the forward chamber 62 thereby preventing a desired flashback of the patient's blood into the catheter adapter 14. An observable flashback is generally desirable to confirm accurate placement of the catheter tip 20 within the vein of the patient. Thus, some embodiments of the present invention include features or elements to enable airflow between the forward chamber 62 and the rearward chamber 64, without requiring activation of the septum 50 with the septum activator 80. As such, some embodiments of the present invention provide an observable flashback, as generally desired for infusion procedures.

For example, in some embodiments the barrier surface 52 of the septum 50 is modified to include leak orifice 58, as previously discussed. In other embodiments, a plurality of air vent channels 70 is interposed between the septum 50 and the inner surface 24 of the catheter adapter 14. The air vent channels 70 relieve the positive pressure within the forward chamber 62 by providing an access for air to bypass the septum 50 into the rearward chamber 64. In some embodiments, the air vent channels 70 are constructed by removing portions of the channel 60 surface, resulting in a plurality of generally parallel grooves.

In addition to permitting air flow between the forward and rearward chambers 62 and 64, the vent channels 70 may be configured to permit fluid to flow through the catheter adapter 14 prior to activating or opening the slit 56 with the septum activator 80. In some embodiments, the rate at which air and/or fluid flows between the forward and rearward chambers 62 and 64 is adjusted by manufacturing the catheter adapter 14 to include a greater or lesser number of vent channels 70. In other embodiments, the rate at which air and/or fluid flows between the forward and rearward chambers 62 and 64 is adjusted by manufacturing the catheter adapter 14 to include vent channels 70 having a greater or lesser cross-sectioned area. Thus, in some embodiments the rate at which air and/or fluid flows between the forward and rearward chambers 62 and 64 is increased by manufacturing a catheter adapter 14 having either an increased number of vent channels 70, or vent channels 70 having a greater cross-sectioned area. Conversely, in other embodiments the rate at

which air and/or fluid flows between the forward and rearward chambers 62 and 64 is decreased by manufacturing a catheter adapter 14 having either a decreased number of vent channels 70, or vent channels 70 having a lesser cross-sectioned area.

With continued reference to FIG. 5A, the septum activator 80 comprises a probe-like structure that is primarily housed in the rearward chamber 64 of the catheter adapter 14. The septum activator 80 generally comprises a tubular body 82 having a distal end 84 and a proximal end 86. The tubular body 82 comprises a rigid or semi-rigid material, such as a plastic or metallic material. The tubular body 82 further comprises an inner lumen 88 for facilitating flow of a fluid and/or liquid through the septum activator 80.

The distal end 84 of the tubular body 82 is configured to compatibly insert within the opening 54 of the septum 50. The distal end 84 further includes a probing surface 90 which extends through the opening 54 of the septum 50 to a position proximal to the barrier surface 52 of the septum 50, as shown in FIG. 8. The probing surface 90 is advanced through the slit 56 and 66, or through the leak orifice 58 as the septum activator is advanced through the catheter adapter 14 in a distal direction 390. Advancement of the septum activator 80 through the catheter adapter 14 will be discussed in detail below, in connection with FIGS. 7 and 8.

Still, in other embodiments the septum 50 is coated with a hydrophobic coating, or a polymeric swelling coating to repel or prevent fluid from flowing through the vent channels 70. A hydrophobic coating is generally selected to reduce the surface energy of the septum 50 and/or adapter 14 to inhibit blood wicking into the air vents 70. In some embodiments, a surface of the septum 50 or catheter adapter 14 is coated with a polyxylylene polymer material, such as Parylene. In other embodiments, a polyxylylene polymer coating is applied to a vent channel 70 via vapor deposition.

In some embodiments, a dehydrated polymer material is applied to a surface of the septum 50 or catheter adapter 14 which comprises the vent channels 70. A dehydrated polymer is generally selected to expand or swell upon contact with fluid. As such, when the dehydrated polymer swells, a flow through the vent channels 70 is blocked or occluded by the swollen polymer. Initially, the dehydrated polymer generally comprises a thin profile prior to exposure to moisture. However, when exposed to moisture the polymer absorbs the moisture which increases the profile of the polymer to block flow through the vent 70. Therefore, by coating the septum 50 and/or catheter adapter 14 with a desired coating, flow of air is permitted between the forward and rearward chambers 62 and 64, yet fluid flow through the vent channels 70 is prevented.

Referring now to FIG. 5B, an embodiment of a septum 150 is shown. In some embodiments, an outer surface 166 of the septum 150 is modified to include a plurality of recessed grooves 72. The recessed grooves 72 provide pathways between the forward and rearward chambers 62 and 64 through which air and/or fluid may flow. Thus, in some embodiments the channel 60 does not include air vent channels 70, but rather the outer surface 166 of the septum 150 is modified to provide desired flow between the forward and rearward chambers 62 and 64.

The blood pressure of the patient is largely responsible for the rate at which blood and air flows through the septum 50 and 150 of the catheter assembly 101. As such, the flow rate through the system is affected by the combined effective hydraulic diameter of all flow paths. Thus, in some embodiments the hydraulic diameter of the vent channels 70 and/or recessed grooves 72 are modified to increase or decrease the

rate of flow through the catheter assembly 101. In other embodiments, the hydraulic diameter of the vent channels 70 and/or recessed grooves 72 are decreased thereby resulting in substantially reduced or stopped flow through the ventilation means. The governing equation for controlling the flow rate through the ventilation means is given in Equation 1, where BP is the blood pressure, A is the surface area of the ventilation means, σ is the surface tension of the blood, and P is the perimeter of the ventilation means.

$$BP(A)=\sigma(P)$$

Equation 1:

Thus, according to Equation 1, when the perimeter of the ventilation means is small, the ventilation means will allow air venting, but will prevent blood flow due to the relatively high surface tension (σ) of blood. However, when the perimeter of the ventilation means is increased, the surface tension between the blood and the vent is decreased thereby enabling the blood to slowly leak through the vents and around the septum to provide desirable, yet controlled flashback. Therefore, by adjusting the various variable of Equation 1, a desired flow will be achieved. Thus, based on the size and/or number of vents around the septum, the catheter assembly design will provide customized, controlled and predictable blood flow around the septum 50 or 150. In some embodiments, it is desirable to permit slow, controlled blood flow as a means for providing a visual indicator that the catheter is in the blood vessel, without the risk of immediate exposure to the blood. In other embodiments, it is desirable to only permit air to pass through the vents.

Referring now to FIG. 6A, a cross-section view of an interior lumen of a catheter adapter 14 is shown. In some embodiments, catheter adapter 14 includes a forward fluid chamber 62 and a rearward fluid chamber 64 fluidly connected via a narrowed channel or port 160. As configured and in some embodiments, a fluid pathway 170 is defined whereby a fluid 146 flows downstream from the rearward fluid chamber 64, through the port 160 and into the forward fluid chamber 62. The fluid pathway 170 continues through the forward fluid chamber 62 and exits the distal end 32 into a catheter (not shown) or other downstream conduit. While fluid 146 fills the entire lumen of the catheter adapter 14, the fluid pathway 170 is generally restricted to a narrow pathway through a central portion of the cross-section of the catheter adapter 14. Accordingly, fluid 146 that is not part of the narrow fluid pathway 170 stagnates or circulates within dead zones 156. Fluid 146 trapped within these dead zones is prevented from sufficiently mixing with fluid 146 in the fluid pathway 170. In some embodiments, stagnation results in increased, localized concentrations of chemicals, bodily fluids and/or medicaments that may lead to precipitation, coagulation or administration of dangerously high doses of medications. Therefore, in some embodiments of the present invention, a septum activator 80 is provided having features to eliminate dead zones 156 within the catheter adapter 14 lumen.

Referring now to FIG. 6B, a perspective view of the septum activator 80 is shown. In some embodiments, the distal end 84 of the tubular body 82 comprises a first diameter 100 that is less than a second diameter 102 of the proximal end 86. The narrower distal end 84 is configured to compatibly insert within the opening 54 of the septum 50, while the wider proximal end 86 is configured to compatibly seat within the rearward chamber 64 of the catheter adapter 14. In some embodiments, the septum activator further includes a tapered middle section 104 to couple the distal 84 and proximal 86 ends.

In some embodiments, the proximal end 86 of the septum activator 80 further includes a retention spring 110. The retention spring 110 generally comprises an outwardly biased portion of the tubular body 82 configured to compatibly engage a septum activator retention groove 68, as shown in FIGS. 5A, and 7-8. The interaction between the retention spring 110 and the groove 68 limits the lateral movement of the septum activator 80 within the lumen 16 of the catheter adapter 14. Thus, the width of the retention groove 68 determines or limits the distance of travel for the septum activator 80 within the catheter adapter 14. Additionally, the interaction between retention spring 110 and the groove 68 prevents removal of the septum activator 80 from the catheter adapter 14. In some embodiments, the septum activator 80 comprises a plurality of retention springs 110, while in other embodiments the septum activator 80 comprises a single retention spring 110.

In some embodiments, the septum activator 80 further comprises features for directing or diverting fluid flow around and/or through the septum activator 80. Flow diversion may be important to prevent stagnation or coagulation of fluids within dead zones 156 of the septum activator 80 and/or the lumen 16 of the catheter adapter 14 resulting in blockages. Additionally, stagnation of fluid flow through the catheter assembly 101 may result in a build up of undesirable concentrations of medicaments within the catheter adapter 14 and/or the septum activator 80, as previously discussed. Undesirable high concentrations may result in ineffective treatment causing serious side effects, including death. Thus, in some embodiments the septum activator 80 is modified to include flow deflectors 120 and flow diversion channels 130 to provide a flushable catheter assembly 101 system.

The flow deflectors 120 generally comprise inwardly and outwardly angled portions of the septum activator 80 outer surface. The flow deflectors 120 are positioned so as to protrude into a flow path through the catheter adapter 14. Thus, as the fluid contacts the flow deflectors 120 the path of the fluid flow is disturbed. This disturbance results in redirecting the fluid flow both through the inner lumen 88 of the septum activator 80, and between the outer surface of the septum activator 80 and the inner surface 24 of the catheter adapter 14. In some embodiment, the retention spring 110 also serves as a flow deflector 120.

A flow diversion channel 130 is provided to permit exchange of fluid between the lumen of the catheter adapter 16 and the inner lumen 88 of the septum activator 80. Thus, the flow diversion channel 130 prevents stagnation and/or clotting of fluid between the inner surface 24 of the catheter adapter 14 and the outer surface of the septum activator 80. In some embodiments, the flow diversion channel 130 comprises a window or opening in the surface of the tubular body 82. In other embodiments, the flow diversion channel 130 further comprises a flap or angled surface to further direct fluid to flow through the channel 130.

The proximal end 86 of the septum activator 80 further includes a contact surface 140. The contact surface 140 comprises the most proximal end portion of the septum activator 80 and is positioned within the rearward chamber 64 of the catheter adapter 14 adjacent to the proximal opening 26 of the catheter adapter 14, as shown in FIG. 7, below.

Referring now to FIG. 6C, an embodiment of a septum activator 180 is shown as positioned in the lumen of a catheter adapter 14 (shown in phantom). In some embodiments, septum activator 180 is configured to include various re-circulation features. For example, in some embodiments septum activator 180 includes various vents 200 configured to divert fluid from the fluid pathway 170 into the dead zones 156.

13

Thus, as fluid flows into and through the septum activator **180**, the fluid within the septum activator **180** passes through the vents **200** and into the dead zones **156** between the outer surface of the activator **180** and the inner wall surface of the catheter adapter **14**. The diverted fluid intermixes with the fluid in the dead zones **156** to flush fluid from the dead zones **156** and thus prevent stagnation and/or overconcentration, as previously discussed.

In some embodiments, septum activator **180** is further modified to include flushing fins **220**. Flushing fins **220** generally comprise perpendicular extension of the outer surface of the activator **180** that extend into the dead zones **156** between the activator **180** and the inner wall surface of the catheter adapter **14**. The flushing fins **220** are provided to divert and redirect fluid within the fluid pathway **170** into the dead zones **156**. As such, fluid within the dead zones **156** is intermixed with fluid in the fluid pathway **170** to prevent stagnation and/or overconcentration of fluid within the catheter adapter **14**.

Finally, in some embodiments the flow diversion channel **130** is modified to include a flow deflector **230**. The flow deflector **230** comprises a beveled, distal surface of the flow diversion channel **130** positioned to divert fluid within the fluid pathway **170** into the dead zones **156** of the forward fluid chamber **62**. Thus, as fluid **146** flows through the septum activator **180**, a portion of the fluid is diverted through the flow diversion channel **130** and into the dead zone **156** via the flow deflector **230**, as shown in FIG. 6D.

With continued reference to FIG. 6D, a cross-sectioned septum activator **180** positioned within a cross-sectioned catheter adapter **14**. As previously discussed, recirculation features may be added to both the proximal **86** and distal **186** ends of the septum activator **180**. In some embodiments, the proximal end **86** of the septum activator **180** is modified to include curved window features **240** that redirect the flow of a fluid **246** into the dead zones **156** of the rearward fluid chamber **64**. Thus, the curved surface **242** of the window feature **240** alone and/or in combination with the other recirculation features promotes intermixing of the fluid within the dead zones **156** to prevent stagnation and overconcentration of fluids within the catheter adapter **14**.

In some embodiments, the recirculation features are positioned in a symmetrical configuration to induce best flushing. In other embodiments, the recirculation features are positioned in an asymmetrical configuration to induce best flushing. Finally, in some embodiments the recirculation features are used in combination with additional diffusing, circulating and recirculating features of the septum activator **180** to aid the fluid flushing capability of the septum activator **180**. In light of the foregoing disclosure, additional surfaces of the septum activator **180** may be modified to increase or decrease flow efficiency, mixing and flushing of fluids within the septum activator **180**, as desired.

Referring now to FIG. 7, a cross-sectional view of the assembled catheter assembly **101** is shown prior to activation of the septum **50** via the septum activator **80**. Prior to activation, the septum activator **80** is entirely positioned within the rearward fluid chamber **64** of the catheter adapter **14**. Additionally, the retention springs **110** are engaged within the retention groove **68** and positioned near the proximal end of the retention groove **68**. The contact surface **140** of the septum activator **80** is positioned near the opening **26** of the catheter adapter **14**, such that a proximal opening **142** of the septum activator **80** is in a plane generally parallel to the plane of the catheter adapter opening **26**. Finally, the outwardly biased retention springs **110** bind on the surface of the groove

14

68 thereby maintaining the inactivated position of the septum activator **80** within the catheter adapter **14**.

Referring now to FIG. 8, a cross-sectional view of the catheter assembly **101** is shown following activation of the septum **50** via the septum activator **80**. Upon insertion of the coupler **42** into the proximal opening **26** of the catheter adapter **14**, the probe portion **46** of the coupler **42** contacts the contact surface **140** of the septum activator **80**. The septum activator **80** is advanced in a distal direction **390** as the coupler **42** is further inserted into the proximal opening **26** of the catheter adapter **14**. As the coupler **42** is advanced further into the proximal opening **26**, the probing surface **90** of the septum activator **80** passes through the barrier surface **52** of septum **50**. As such, the probing surface **90** of the septum activator **80** is positioned within the forward chamber **62** providing a fluid pathway through the septum **50**.

In some embodiments, the catheter assembly **101** is configured to permit the septum activator **80** to return to a position entirely within the rearward chamber **64** following removal of the coupler **42** from the catheter adapter **14**. Thus, when the coupler **46** is removed or detached from the catheter assembly **101**, the fluid pathway through the septum **50** is reclosed. In some embodiments, the retention spring **110** is configured to flex inwardly upon contact between the contact surface **140** of the septum activator **80** and the probe **46** of the coupler **42**. When the retention spring **110** flexes inwardly, the probing surface **90** of the septum activator **80** is temporarily advanced in a distal direction **390** to bias open the slits **66** and **56**, or the leak orifice **58**. When contact between the probe **46** and the contact surface **140** ceases, the retention spring **110** returns to its relaxed position. The relaxed position withdraws the probing surface **90** of the septum activator **80** from the barrier surface **52** thereby permitting closure of the slits **66** and **56**.

Referring now to FIG. 9, a cross-sectional view of a catheter assembly **300** is shown incorporating an introducer needle **350**. The proximal end **352** of the needle **350** may be coupled to a needle hub (not shown) or an insertion assembly (not shown) to facilitate a user in holding and manipulating the needle **350** during catheterization. For purposes of clarity in the present illustration the remainder of the needle assembly has been removed.

Prior to activation, septum activator **380** is entirely positioned within the rearward chamber **364** of catheter adapter **314**. A pathway is provided through the inner lumen **316** of the activator **380** so as to allow passage of introducer needle **350**. A middle portion of the needle **350** passes through septum **356** and continues through the forward chamber **362** and into the flexible catheter **312**. A tip portion (not shown) of the needle **350** extends beyond a tip portion (not shown) of the catheter **312** such that the needle tip is available to gain access to the vasculature of a patient.

The slit **366** of septum **356** is biased open by introducer needle **350**. In some embodiments, a seal is formed between the outer surface of the needle **350** and the slit **366**. Thus, fluid and air flow are prevented from bypassing the septum by way of the interface between the needle **350** and the slit **366**. In some embodiments, a channel or pathway is provided between the slit **366** and the needle **350** to permit controlled leakage or flow between these two components.

In other embodiments, a lubricant such as a non-wetting lubricant is applied to the interface between the needle **350** and the slit **366** to further eliminate possible leakage of fluid and/or air. A non-wetting lubricant may also be beneficial to prevent tearing or other damage to the slit that may occur when the needle is removed from the catheter assembly following catheterization. A non-wetting lubricant may also

facilitate proper realignment of the slit **366** halves following removal of the needle **350**. Non-limiting examples of a non-wetting lubricant include known Teflon based non-wetting materials such as Endura, from Endura Coating Co.; A20, E-20, 1000-S20, FEP Green, PTFE and X-40 from Tiodize; Cammie 2000 from AEYale; 21845 from Ladd Research; MS 122-22, MS 122DF, MS-143DF, MS-122V MS-122VM, MS143V, MS-136W, MS-145W, U0316A2, U0316B2, MS-123, MS-125, MS-322 and MS-324 from Miller-Stephenson; and 633T2 from Otto Bock can also be used. Various non-Teflon based non-wetting lubricant type materials include Dylun, from ART; Nyebar, Diamonex, NiLAD, TIDLN, Kiss-Cote, Titanium oxide; Fluocad Fluorochemical Coating FC-722, from 3M; Permacote from Dupont; Plasma Tech 1633 from Plasma Tech, Inc.; and silicone sprays.

In some embodiments, distal end **384** of the septum activator **380** is elongated such that contact surface **340** is positioned closer to proximal opening **326** of the catheter adapter **314**. Accordingly, a coupler having a shortened probe portion (not shown) may sufficiently contact the contact surface **340** to advance the distal end **384** through the septum **356**. In other embodiments, the distal end **384** of the septum activator **380** is configured to include an inner diameter of substantially the same size and the outer diameter of the introducer needle **350**. As such the inner diameter of the distal end **384** is configured to allow passage of the needle **350** while maintaining minimal tolerance **382** between the outer surface of the needle **350** and the inner surface of the septum activator **380** distal end **384**. This minimal tolerance **382** provides a seal thereby preventing leakage or flow of blood between the needle **350** and the septum activator **380** while withdrawing the needle **350** from the catheter assembly **300**.

In some embodiments, a translating groove **368** is provided within the rearward chamber **364**. The translating groove **368** generally comprises an annular recess having a determined length **370**. Translating groove **368** is further configured to receive flushing fins **320** such that the flushing fins **320** are retained within the groove **368**. Thus, length **370** represents the maximum lateral distance which septum activator **380** is permitted to travel within the rearward chamber **364**. In some embodiments, a proximal end of groove **368** is defined by an annular ridge **372**. In other embodiments, a distal end of groove **368** is defined by a second annular ridge **374**. Still, in other embodiments the second annular ridge **374** forms a proximal end of septum channel **60**.

Referring now to FIG. **10**, a cross-sectional view of catheter assembly **300** is shown following removal of introducer needle **350**. Upon removal of introducer needle **350**, slit **366** of septum **356** is no longer biased open and therefore recloses and seals to prevent flow of fluids and/or air via the slit **366**. As previously discussed, in some embodiments slit **366** includes a leak orifice (not shown) to permit controlled flow between the forward and rearward chambers **362** and **364**. In other embodiments, a plurality of ventilation channels **70** are provided between the outer surface of the septum **356** and the septum channel **60**.

Referring now to FIGS. **11A** through **11D**, septum **356** may include various configurations and features to stabilize distal end **384** of the septum activator **380**. For example, in some embodiments septum **356** is configured to include an inner diameter **358** sized substantially equal to the outer diameter of the distal end **384** of septum activator **380**, as shown in FIG. **11A**. In other embodiments, septum **356** is configured to have an interior annular ridge or protrusion **360** having an inner diameter **358** sized substantially equal to the outer diameter

of distal end **384**, as shown in FIG. **11B**. Thus, in both of these embodiments distal end **384** is radially supported by septum **356**.

With reference to FIG. **11C**, in some embodiments an interior surface **376** of septum **356** is modified to include one or more reliefs **391**. In some embodiments, relief **391** comprises a concave annular recess configured to receive a positive feature **392** comprising a portion of distal end **384** of the septum activator **380**. In other embodiments, relief **391** comprises a singular indent sized and configured to receive feature **392** of the septum activator **380**. Still, in other embodiments relief **391** comprises a positive feature and feature **392** comprises a negative or recessed feature (not shown). Thus, in some embodiments the interaction between relief **391** and feature **392** provides both radial support and axial retention of the septum activator **380** within the catheter adapter **314**. This configuration may eliminate the need for additional retention features, such as clips and retention grooves.

Referring now to FIG. **11D**, septum **356** includes a domed profile **394** to counteract pressure applied to the distal side **386** of the septum **356** following removal of introducer needle **350**. The domed profile **394** provides additional strength to the distal side **386** of the septum **356** thereby increasing the fluid pressure required to defeat the septum **356**. In some embodiments, as the blood reaches the septum **356** the domed profile **394** assists the septum **356** in closing due to the pressure from the blood flow within the forward chamber **362**. In other embodiments, septum **356** comprises a generally flat profile, as shown in FIGS. **5A**, **5B** and **7** through **11C** or may include a combination of flat and curved surfaces (not shown).

Referring now to FIG. **12**, a cross-sectional view of catheter assembly **300** is shown following activation of septum **356** via septum activator **380**. Upon insertion of a coupler **342** into the proximal opening **326** of the catheter adapter **314**, the probe portion **346** of the coupler **342** contacts the contact surface **340** of septum activator **380**. Septum activator **380** is accordingly advanced in a distal direction **390** as the coupler **342** is further inserted into proximal opening **326** thereby causing flushing fins **320** to translate within translating groove **368**. As coupler **342** is advanced further into the proximal opening **326**, probing surface **348** of the septum activator **380** passes through the slit **366** of septum **356**. As such, the probing surface **348** of the septum activator **380** is positioned within the forward chamber **362** providing a fluid pathway through the septum **356**.

Referring now to FIGS. **13** through **20**, a number of valves in accordance with some embodiments are shown which aim to further eliminate or reduce areas of low or no fluid flow occurring within a vascular access device containing a valve mechanism comprising a septum and septum activator or pusher.

FIGS. **13** and **14** show an embodiment of the invention in which a sleeve **45** is used to prevent fluid from flowing into any interstitial spaces which are low or no flow fluid areas.

FIG. **13** shows a septum **43** which forms a fluidic seal in the lumen **341** of catheter body **41** after removal of the needle, with septum activator or pusher **344** in the proximal position. Sleeve **45** is attached around pusher **344** to form a fluid seal between an outer periphery **53** of proximal portion **348** of pusher **344** and inner surface **354** of lumen **341**. Thus, no fluid can flow between the proximal end of pusher **344** and the inner surface **354** of lumen **341** into the interstitial space **498**. FIG. **14** shows pusher **344** in the distal position in which fluid can only flow via the lumen **51** of pusher **344**. Sleeve **45** still maintains a fluidic seal between outer periphery **53** of pusher **344** and inner surface **54** of lumen **341**. Thus, no fluid can flow

into the interstitial spaces 498. In addition, the tapered outer surface 351 of the distal portion of sleeve 45 reduces the size of the interstitial space 498 when pusher 344 is in the distal position. Sleeve 45 is made from a softer elastomeric material, such as liquid silicone rubber for example, and is attached to pusher 344 through suitable molding procedures, such as insert molding, injection molding, and other molding techniques or a combination of molding techniques.

FIGS. 15 and 16 show another embodiment of the invention having valve mechanism which uses a seal at the proximal end 65 and distal end 75 of a tubular septum activator 365, to prevent fluid from flowing into interstitial spaces 698 and 699 between activator 365 and the inner surface 74 of the lumen 363 of the catheter body 61. Distal seal 75 is incorporated into septum 63 to prevent any fluid flowing between the distal end of activator 365 and the proximal surface of septum 63 when pusher is in the proximal position as shown in FIG. 15 or the distal position as shown in FIG. 16. Proximal seal 65 is a continuous torus or toroidal-shaped band around the outer circumference of the proximal end of activator 365 which forms a fluid seal with the inner surface 74 of the lumen 363 of the catheter body 61 in both the proximal and distal activator positions. The proximal seal 65 is made from a softer elastomeric material, such as liquid silicone rubber for example and is over-molded onto activator 365 and retained in position by lip 367 on the outer surface of the proximal end of activator 365. Activator 365 has a number of fins 369 extending from and evenly distributed around the circumference of the outer surface 371. These fins 369 are sufficiently long to contact a portion 73 of the inner surface 74 of lumen 363 and are used to limit the movement of activator 365 along the catheter body by contact with the septum 63 in the distal direction and contact with indent or step 378 of the inner surface 74 in the proximal direction.

FIGS. 17 through 20 show some embodiments having valve mechanisms which are configured to exclude small confined interstitial spaces, thereby eliminating areas of no to low fluid flow.

FIGS. 17 and 18 show an embodiment in which the septum 83 encases the majority of activator 383. Activator 383 includes a head section, tubular section and a plunger. Plunger 381 which has a diameter at least equal to that of lumen 385 of the catheter body 81 such that no fluid can pass between the inner surface 94 and plunger 80 is located at the proximal end of activator 383. Septum 83 has an external diameter at least equal to that of lumen 82 along its entire length such that no interstitial space is present between septum 83 and inner surface 94 of lumen 385. In addition, septum 83 has a lumen 85, the internal diameter of which is equal to the external diameter of tubular section 87 of activator 383 thereby forming an additional fluid seal along the length of tubular section 87. Furthermore, the relative lengths of activator 383 and septum 83 are such that the distal face 389 of plunger 381 is in intimate contact with the proximal end 388 of septum 83 when activator 383 is in the distal position, as shown in FIG. 18. Thus, there is no interstitial space between plunger 381 and septum 83. The head section is located at the distal end of activator 383 and includes longitudinal slots 387 in the side wall of lumen 91 in order to allow fluid flow to diverge out of lumen 91 of activator 383 and reduce the possibility of a no or low flow area 393 around the distal face of septum 83 at the inner surface 74.

FIGS. 19 and 20 show a further embodiment of a valve mechanism in which a septum 103 includes a tubular section 107 having a distal end 108 and a membrane section 109 having a proximal planar surface located at the proximal end 105. The tubular section 107 of septum 103 is substantially

disposed within septum housing 111 and is prevented from distal movement by shoulder or annular recess 121 formed in surface of lumen 385. A fluidic seal is formed between the periphery of membrane section 109 and inner surface 114 of the proximal section 110 of lumen 385 to prevent fluid leakage past septum 103 when the valve is closed. In some embodiments, septum 103 further includes a needle slit 113 or valve aperture located about the centre of membrane section 109, extending through membrane section 109, to facilitate penetration of septum 103 by introducer needle 5. A septum activator 304 is located in the proximal section of lumen 385 and includes a tubular portion 115. In some embodiments, tubular or sleeve portion 115 further includes a plurality of longitudinal slots or flow channels 116 in the side wall, distributed evenly around the circumference of tubular portion 115 and located at the distal or actuating end 117 such that a gap is formed between the actuating end 117 and membrane 109.

FIG. 19 shows septum activator 304 in the proximal position following removal of introducer needle 5. In particular, the actuating end 117 of septum activator 304 is positioned against the proximal planar surface of membrane section 109 of septum 103 to form an interface. The diameter of lumen 385 in proximal section 310 is approximately equal to the external diameter of connector 106 (e.g. a luer connector) of a vascular access device, septum activator 304 and membrane section 109, such that there are no interstitial spaces between the connector 106 (shown in FIG. 20), a contact end of septum activator 304 and membrane section 109. The inner surface 114 and proximal section 310 of the first lumen 385 are further sealed by membrane section 109.

Referring now to FIG. 20, septum activator 304 is shown in the distal position whereby connector 106 has repositioned septum activator 304 forward in a distal direction thereby causing actuating end 117 of septum activator 304 to deform membrane section 109. This deformation results in the formation of a fluid pathway whereby fluid bypasses membrane section 109 via slots 116, thereafter flowing between periphery of membrane section 109 and inner surface 114, and guided through opening 118 in the side wall of tubular portion 107. This divergent fluid path around the periphery of membrane section 109 causes a turbulent fluid flow which reduces the possibility of stagnation or a low flow area occurring near shoulder 119 in lumen 385. Fluid then continues to flow along the internal diameter of tubular portion 107 and into the distal section 112 of lumen 385.

Any septum described herein may be made of a variety of suitable materials and through a variety of suitable manufacturing methods. For example, the septum may be formed from liquid silicone rubber through suitable molding procedures, such as insert molding, injection molding, other molding techniques, or a combination of molding techniques. The septum 103, or any septum described herein, may also include a coating of antimicrobial substance on any of its surfaces, especially those surfaces which have contact with fluid.

The present invention may be embodied in other specific forms without departing from its structures, methods, or other essential characteristics as broadly described herein and claimed hereinafter. The described embodiments are to be considered in all respects only as illustrative, and not restrictive. The scope of the invention is, therefore, indicated by the appended claims, rather than by the foregoing description. All changes that come within the meaning and range of equivalency of the claims are to be embraced within their scope.

The invention claimed is:

1. A system for controlling fluid flow in a catheter assembly, comprising:

19

an intravenous catheter assembly having a catheter adapter and a needle hub, the catheter adapter having an inner lumen;

a septum disposed within a portion of the inner lumen;

a ventilation channel interposed between the septum and an inner surface of the inner lumen of the catheter adapter, the ventilation channel having a surface area and perimeter selected to permit passage of air and prevent passage of blood;

a slit formed through the septum;

a coating, formed of vapor deposited polyxylylene polymers, disposed [within the slit] *on at least a portion of the surface* of the septum, the coating having a thickness of between approximately 0.00005 to 0.0005 millimeters; and

an introducer needle having a first end and a second end, the first end being coupled to the needle hub and the second end extending through the inner lumen of the catheter adapter, a middle portion of the introducer needle being positioned within a portion of the septum.

2. The system of claim 1, wherein the thickness of the coating is between 0.0001 to 0.0002 millimeters.

3. The system of claim 2, further comprising a lumen forming a fluid pathway through [the] *a* septum activator, the lumen having an inner diameter configured to permit passage of the introducer needle.

4. The system of claim 1, further comprising a septum activator disposed within a portion of the inner lumen adjacent to the septum, a distal end of the septum activator contacting a proximal surface of the septum, and a proximal end of the septum activator being positioned adjacent to an opening of the catheter adapter, wherein the proximal end of the septum activator is accessed by inserting an external device into the opening of the catheter adapter.

5. The system of claim 1, [wherein the] *further comprising a septum activator [comprises], said septum activator comprising* a plurality of vents and flow diverters configured to improve circulation of a fluid within at least one of the septum activator and an interstitial space between the septum activator and the inner surface of the inner lumen.

6. The system of claim 1, further comprising a flow vent interposed between an outer surface of the introducer needle and an inner surface of [the] *a* septum activator lumen, wherein a rate of flow through the flow vent is determined by adjusting at least one of an outer diameter of the introducer needle and the inner diameter of the septum activator lumen.

7. A method manufacturing a catheter assembly having features for controlling fluid flow within the catheter assembly, the method comprising:

providing an intravenous catheter assembly having a catheter adapter and a needle hub, the catheter adapter having an inner lumen;

disposing a septum within the inner lumen, the septum having a slit therethrough;

providing a ventilation channel between the septum and an inner surface of the inner lumen of the catheter adapter, the ventilation channel having a surface area and perimeter selected to permit passage of air and prevent passage of blood;

coating *at least a portion of the surface* of the septum [and the slit] with a coating having a thickness of between approximately 0.00005 to 0.0005 millimeters, the coating being formed of vapor deposited polyxylylene polymers;

positioning an introducer needle within the catheter adapter, wherein a first end of the introducer needle is coupled to the needle hub and a second end of the intro-

20

ducer needle extends through the inner lumen of the catheter adapter, a middle portion of the introducer needle being positioned within a portion of the septum.

8. The method of claim 7, wherein the thickness of the coating is between 0.0001 to 0.0002 millimeters.

9. The method of claim [8] 7, further comprising providing a lumen forming a fluid pathway through [the] *a* septum activator, the lumen having an inner diameter configured to permit passage of the introducer needle.

10. The method of claim 7, further comprising disposing a septum activator within a portion of the inner lumen adjacent to the septum, a distal end of the septum activator contacting a proximal surface of the septum, and a proximal end of the septum activator being positioned adjacent to an opening of the catheter adapter, wherein the proximal end of the septum activator is accessed by inserting an external device into the opening of the catheter adapter.

11. The method of claim 7, further comprising [modifying the] *providing a* septum activator [to include] *including* a plurality of vents and flow diverters configured to improve circulation of a fluid within at least one of the septum activator and an interstitial space between the septum activator and the inner surface of the inner lumen.

12. The method of claim 8, further comprising providing a flow vent interposed between an outer surface of the introducer needle and an inner surface of the septum activator lumen, wherein a rate of flow through the flow vent is determined by adjusting at least one of an outer diameter of the introducer needle and the diameter of the septum activator lumen.

13. An intravenous catheter assembly, comprising:
a catheter adapter having an inner lumen, the inner lumen having a proximal end, a distal end and a middle portion;
a recess forming the middle portion of the inner lumen;
a septum disposed within the recess, the septum forming a defeatable barrier between the proximal end and the distal end of the inner lumen;

a ventilation channel interposed between the septum and an inner surface of the inner lumen of the catheter adapter, the ventilation channel having a surface area and perimeter selected to permit passage of air and prevent passage of blood;

a coating disposed [within a slit] *on at least a portion of the surface* of the septum, the coating having a thickness of between approximately 0.00005 to 0.0005 millimeters, the coating being formed of vapor deposited polyxylylene polymers;

an introducer needle positioned within the inner lumen, a portion of the needle extending through the inner lumen, such that a tip portion of the introducer needle extends beyond the catheter adapter, a portion of the introducer needle being inserted through the septum;

a septum activator positioned within the proximal end of the inner lumen, the septum activator having a pathway through which the introducer needle is inserted, the septum activator further having a first end for biasing open a slit of the septum, and a second end having a contact surface; and

an opening forming a proximal end of the catheter adapter, wherein an external device is inserted through the opening to contact the contact surface of the septum activator thereby advancing the first end of the septum activator through the slit of the septum and against the coating.

14. The assembly of claim 13, wherein the thickness of the coating is between 0.0001 to 0.0002 millimeters.

15. The assembly of claim 13, further comprising a flow vent interposed between an outer surface of the introducer

needle and an inner surface of the septum activator pathway, wherein a rate of flow through the flow vent is determined by adjusting at least one of an outer diameter of the introducer needle and an inner diameter of the septum activator pathway.

16. The assembly of claim 13, wherein the septum activator further comprises a plurality of vents and flow diverters configured to improve circulation of a fluid within at least one of the septum activator pathway and an interstitial space between the septum activator and the inner surface of the catheter adapter inner lumen.

17. The assembly of claim 13, wherein a proximal surface of the septum further includes a cavity for housing a distal end of the septum activator, and wherein a distal surface of the septum is dome-shaped.

* * * * *