



US00RE45659E

(19) **United States**
(12) **Reissued Patent**
Geist et al.

(10) **Patent Number:** **US RE45,659 E**
(45) **Date of Reissued Patent:** **Sep. 1, 2015**

(54) **MAGNETIC TARGETING SYSTEM AND METHOD OF USING THE SAME**

5,797,911 A 8/1998 Drewry
5,851,183 A 12/1998 Bucholz
6,074,394 A 6/2000 Krause
6,086,596 A 7/2000 Durham
6,127,597 A 10/2000 Beyar et al.
6,162,228 A 12/2000 Durham
6,168,595 B1 1/2001 Durham et al.
6,226,548 B1 5/2001 Foley et al.

(71) Applicant: **NuVasive, Inc.**, San Diego, CA (US)

(72) Inventors: **Wyatt Drake Geist**, Davie, FL (US);
Christopher Walsh, Jupiter, FL (US)

(73) Assignee: **NuVasive, Inc.**, San Diego, CA (US)

(Continued)

(21) Appl. No.: **14/152,987**

FOREIGN PATENT DOCUMENTS

(22) Filed: **Jan. 10, 2014**

WO WO-2009/105104 A1 8/2009
WO WO-2009/152243 A1 12/2009

Related U.S. Patent Documents

OTHER PUBLICATIONS

Reissue of:

(64) Patent No.: **8,092,460**
Issued: **Jan. 10, 2012**
Appl. No.: **12/338,794**
Filed: **Dec. 18, 2008**

International Preliminary Examination Report on Patentability in International Application No. PCT/US2008/054544 mailed Aug. 24, 2010, 5 pages.

(Continued)

U.S. Applications:

(62) Division of application No. 11/462,592, filed on Aug. 4, 2006, now Pat. No. 8,092,458.

Primary Examiner — Beverly M Flanagan

(74) *Attorney, Agent, or Firm* — Jonathan Spangler; Rory Schermerhorn

(51) **Int. Cl.**

A61B 17/70 (2006.01)
A61B 17/88 (2006.01)

(57) **ABSTRACT**

(52) **U.S. Cl.**

CPC **A61B 17/7032** (2013.01)

The present invention describes a magnetic targeting system suitable for guiding a biocompatible device to a target area within the body (in vivo) and method of using the same. The system includes a targeting member having a steering material and is attached to the biocompatible device. The system also includes at least one anchoring member constructed and arranged for the inclusion of a magnetic material effective for influencing the traversal of the steering material, in vivo. The magnetically influenced anchoring member interacts with the targeting member such that the biocompatible device is positionable relative to the target area.

(58) **Field of Classification Search**

USPC 606/86 A, 246, 250, 279, 914; 600/424
See application file for complete search history.

(56) **References Cited**

U.S. PATENT DOCUMENTS

5,049,151 A * 9/1991 Durham et al. 606/98
5,127,913 A 7/1992 Thomas, Jr.
5,514,145 A 5/1996 Durham et al.

20 Claims, 8 Drawing Sheets

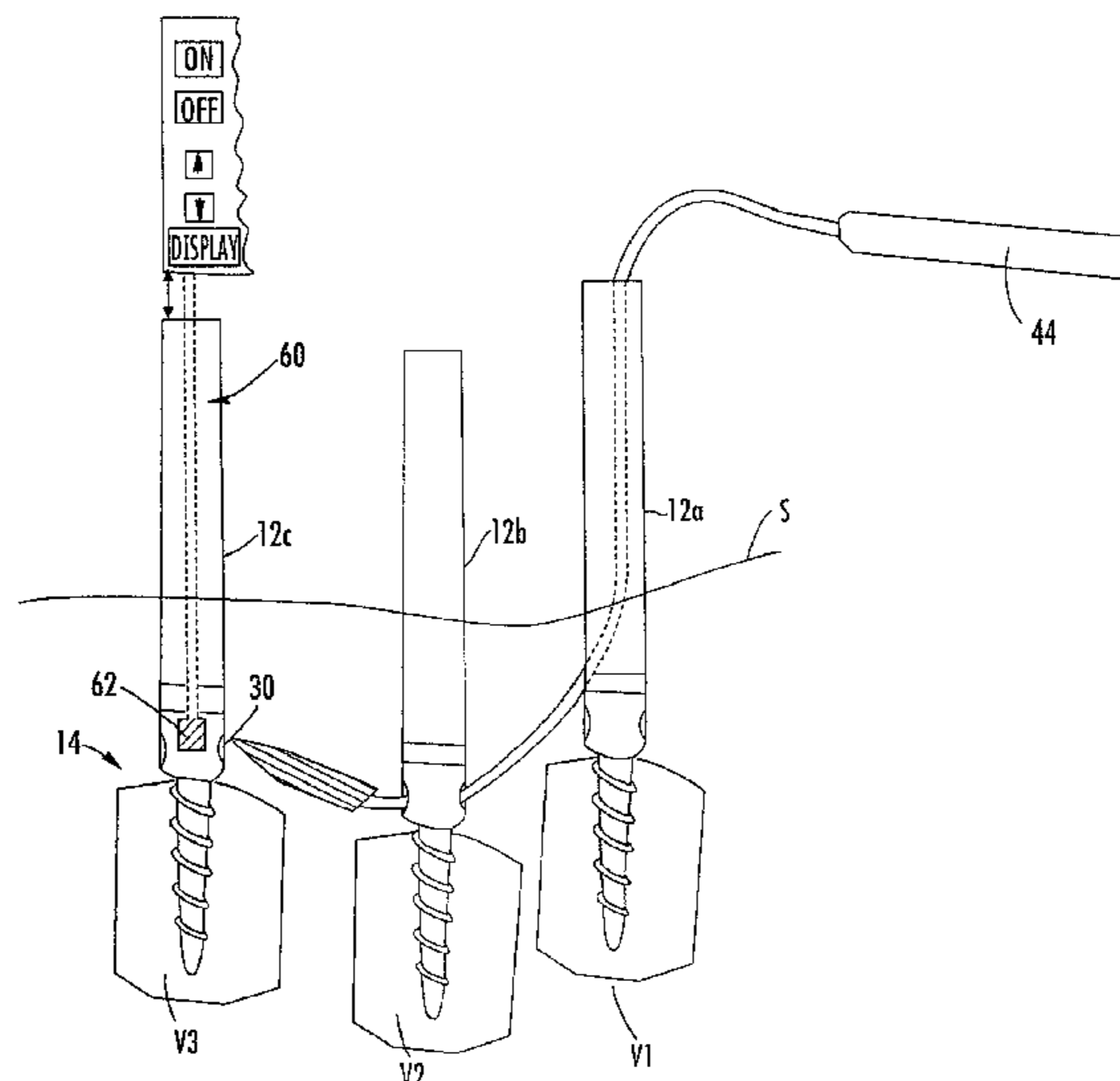

(56)

References Cited

U.S. PATENT DOCUMENTS

6,236,875 B1 5/2001 Bucholz et al.
6,503,249 B1 1/2003 Krause
7,011,660 B2 3/2006 Sherman et al.
7,835,778 B2 11/2010 Foley
7,976,546 B2 7/2011 Geist
8,092,458 B2 1/2012 Geist
8,092,460 B2 1/2012 Geist
8,092,461 B2 1/2012 Geist
8,317,801 B2 11/2012 Geist
8,333,771 B2 12/2012 Geist
8,366,715 B2 2/2013 Geist
2003/0065373 A1 4/2003 Lovett et al.
2005/0055089 A1 3/2005 Macoviak et al.
2005/0075562 A1 4/2005 Szakelyhidi, Jr.
2005/0085714 A1 4/2005 Foley et al.
2005/0277934 A1 12/2005 Vardiman

2006/0079894 A1 4/2006 Colleran
2006/0149135 A1 7/2006 Paz
2007/0191836 A1 8/2007 Justis
2007/0191845 A1 8/2007 Justis
2007/0213714 A1* 9/2007 Justis 606/61
2007/0239159 A1 10/2007 Altarac
2008/0039845 A1 2/2008 Bonutti et al.
2008/0140100 A1 6/2008 Gertner
2008/0312704 A1 12/2008 Hestad
2009/0287255 A1 11/2009 Erickson
2011/0238117 A1 9/2011 Geist

OTHER PUBLICATIONS

International Preliminary Examination Report on Patentability in International Application No. PCT/US2009/046903 mailed Dec. 14, 2010, 5 pages.

* cited by examiner

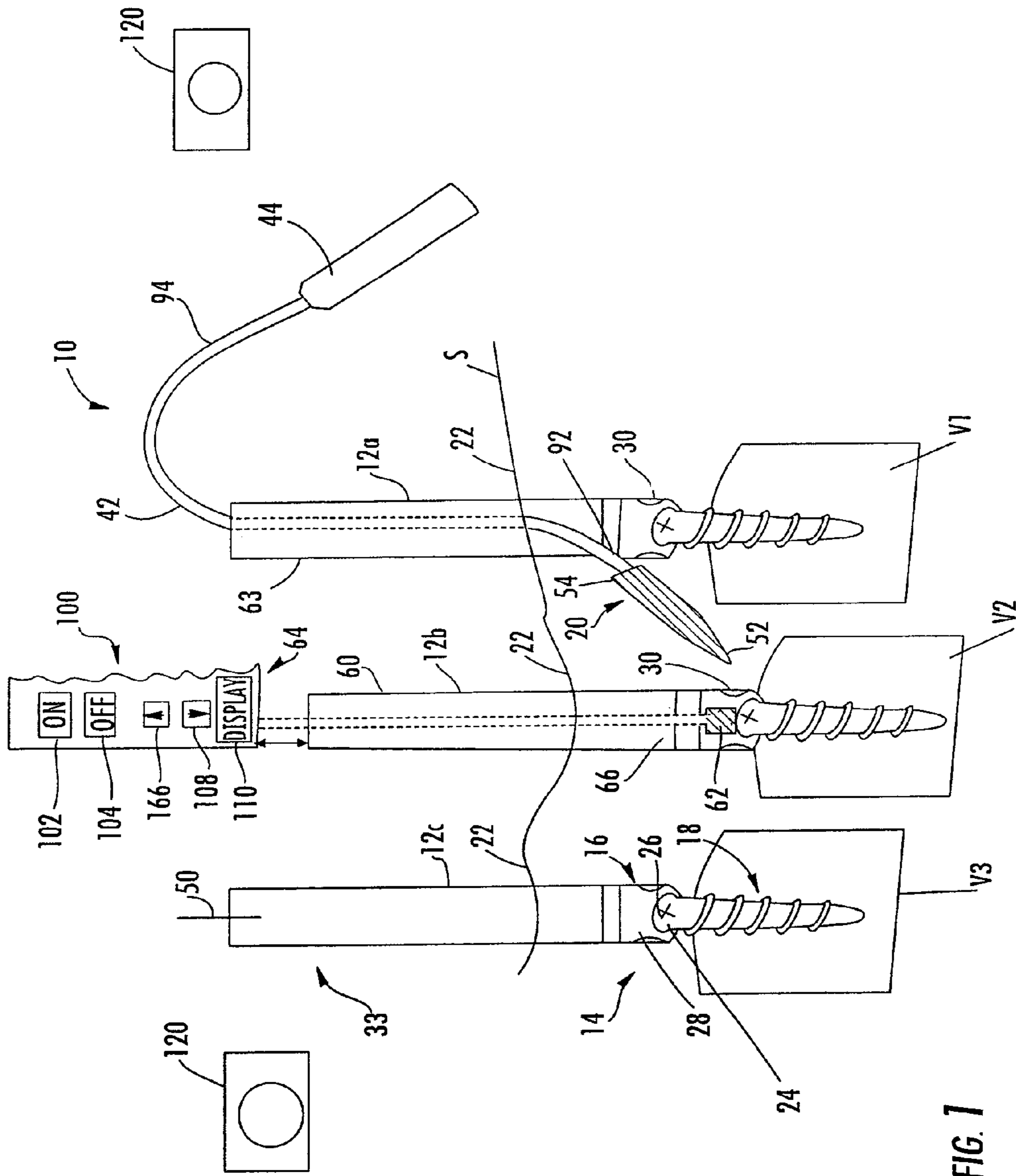

FIG. 7

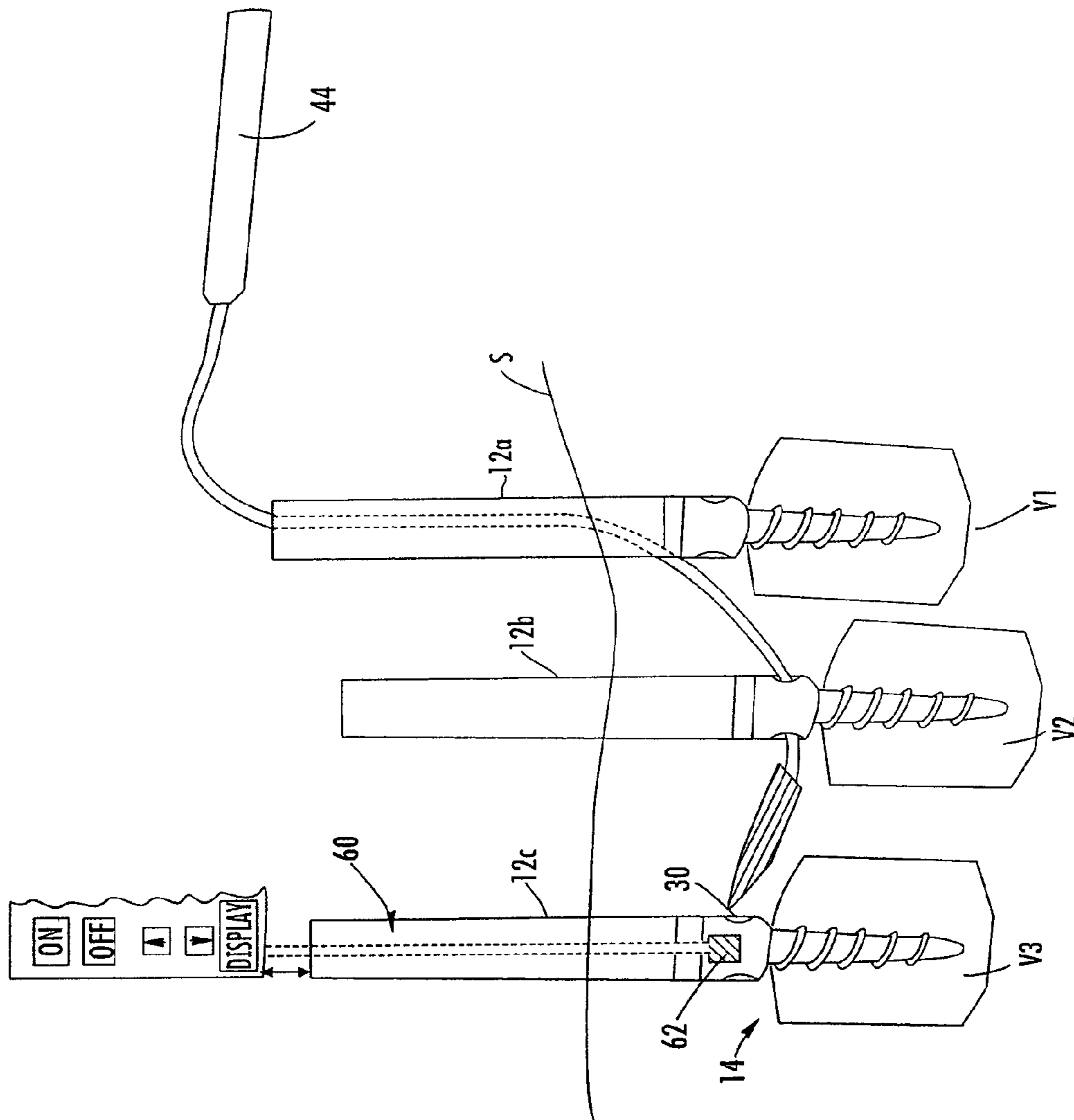

FIG. 2

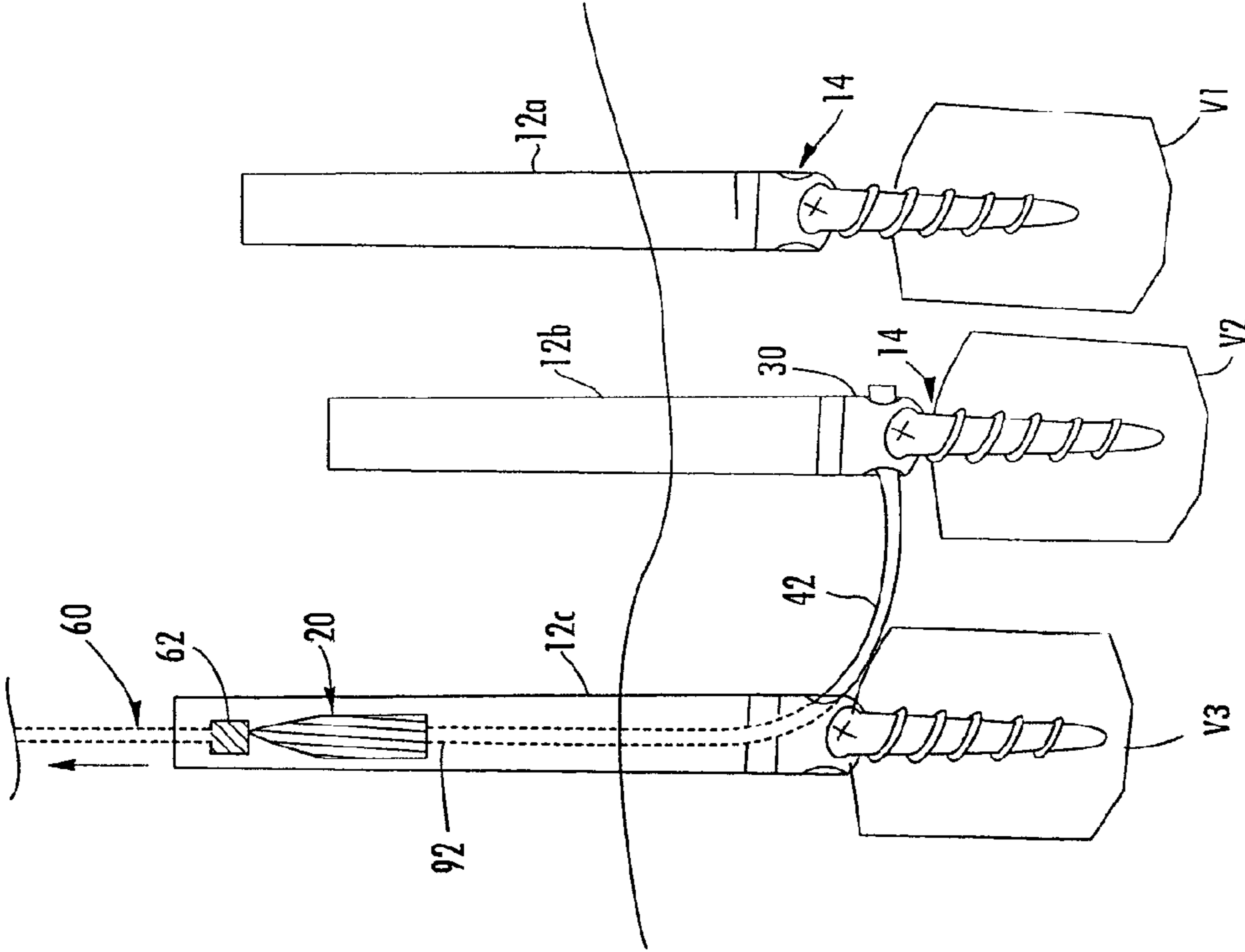

FIG. 3

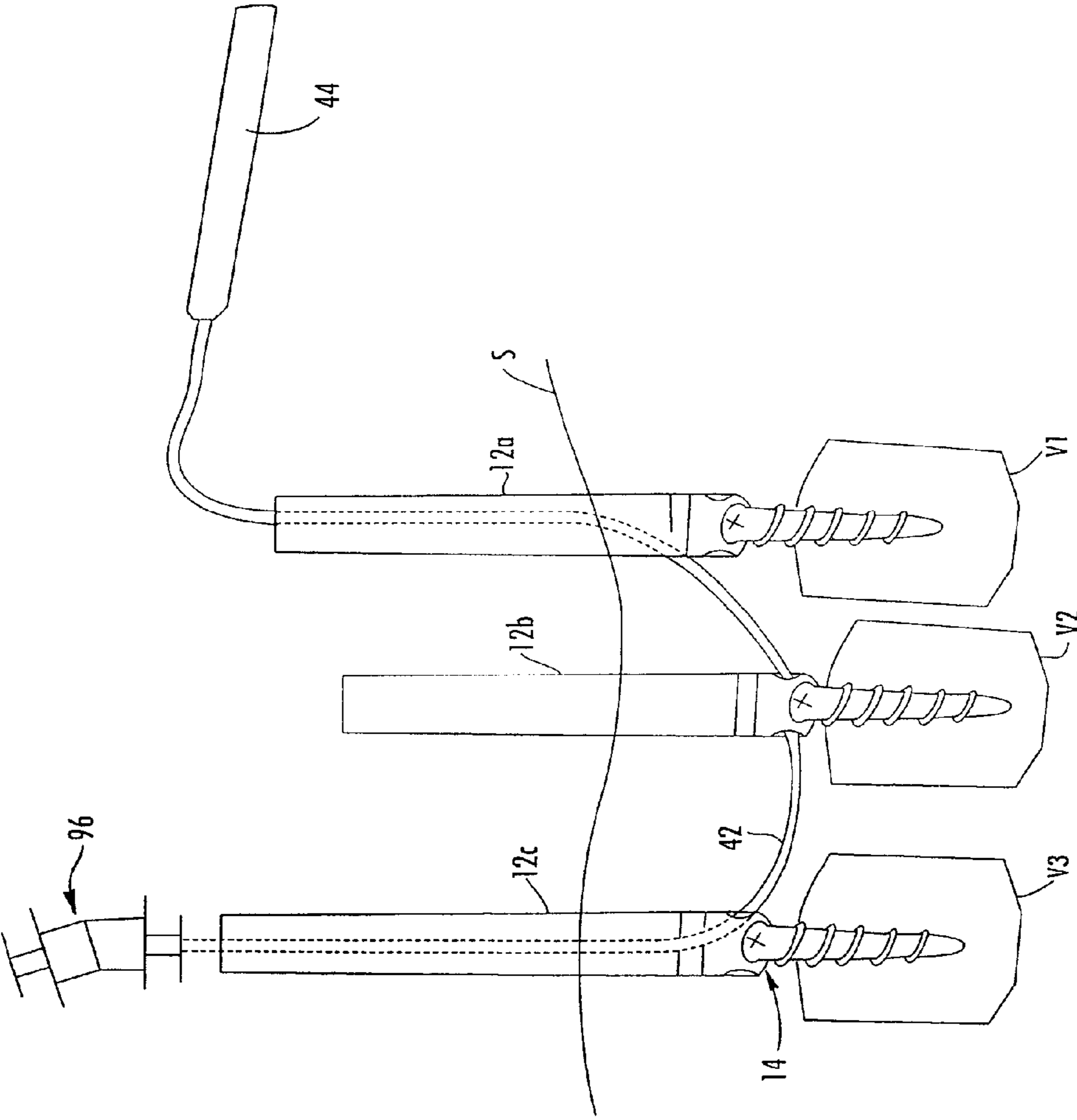

FIG. 4

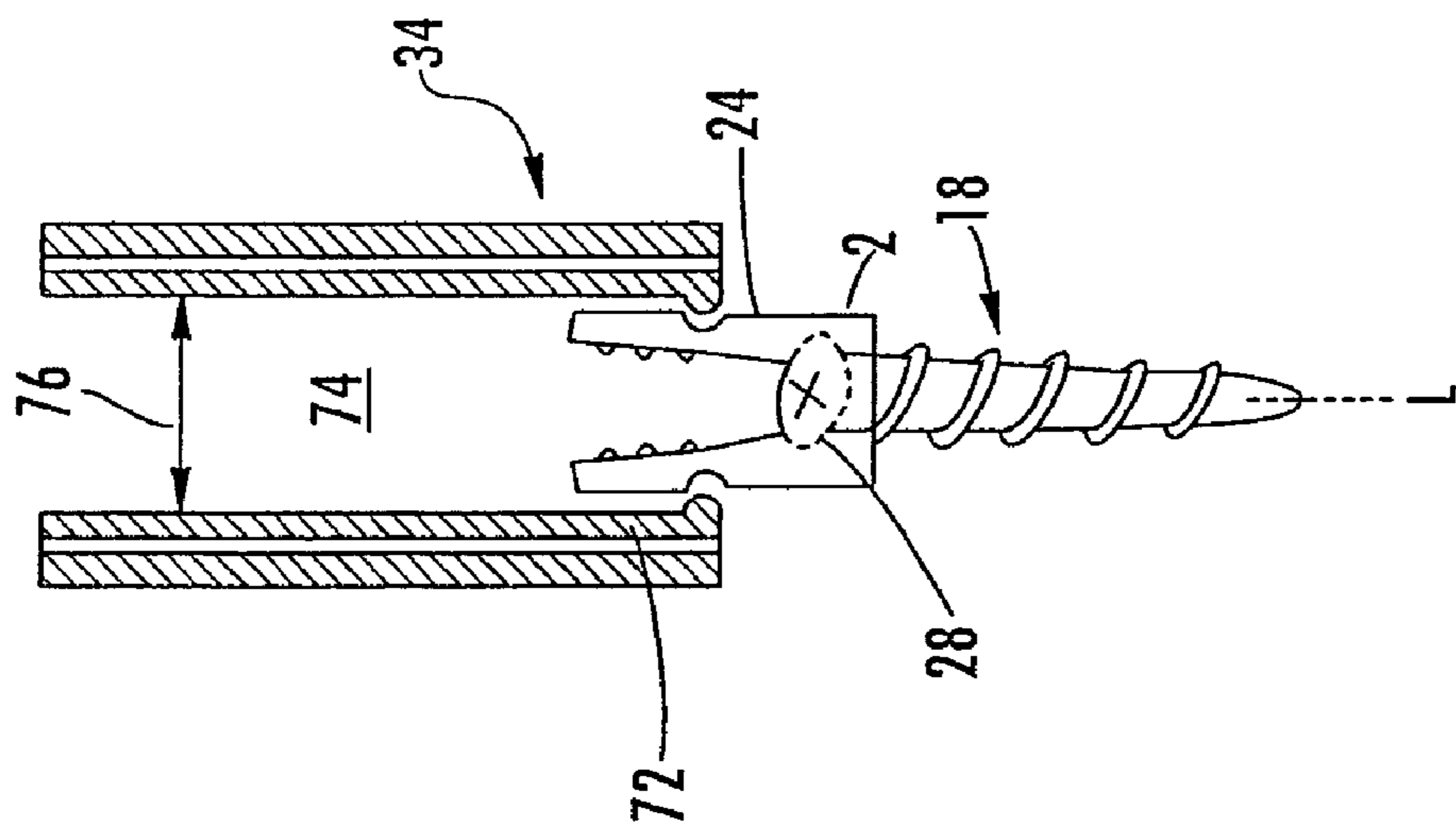

FIG. 5

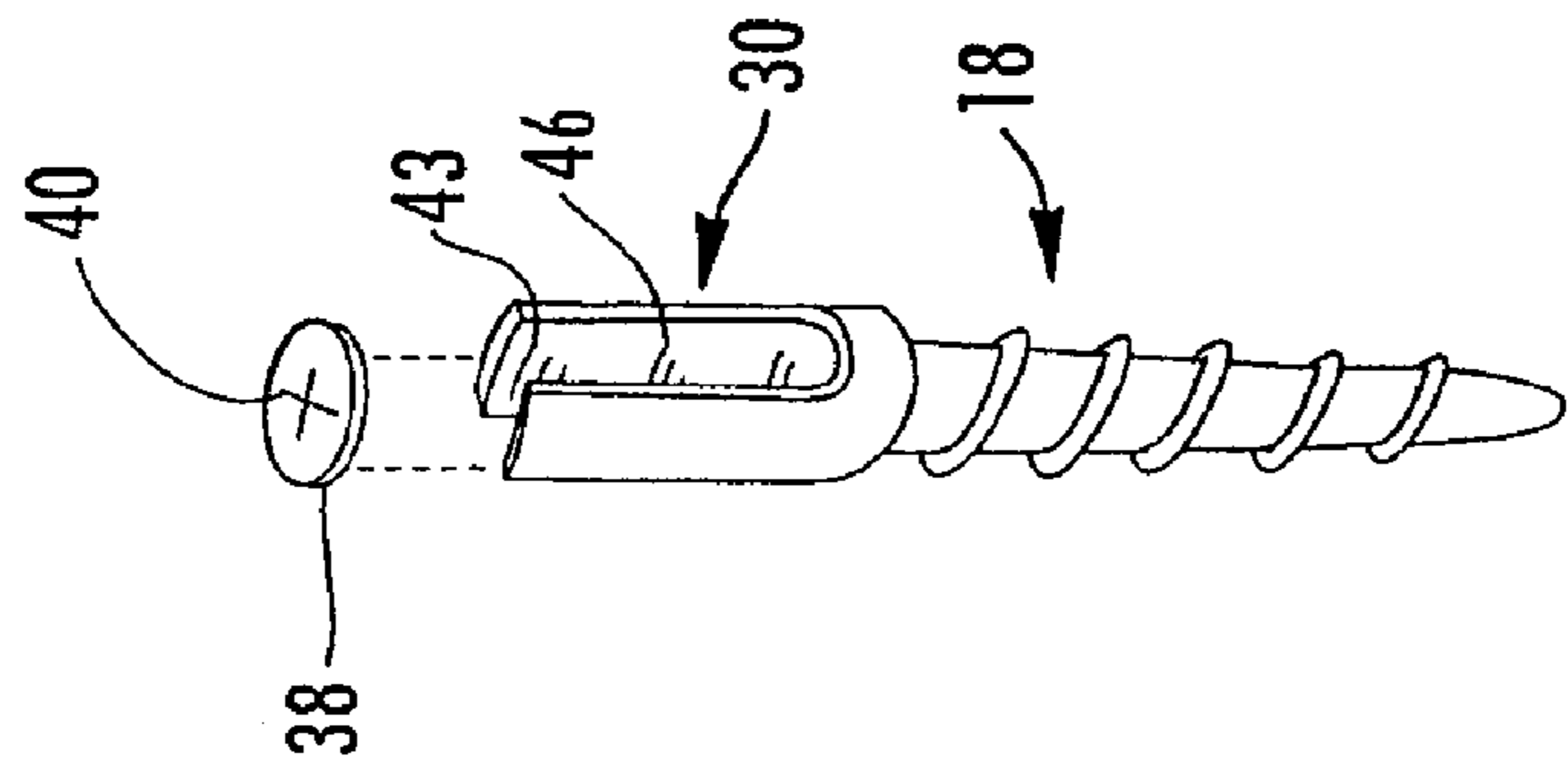

FIG. 6

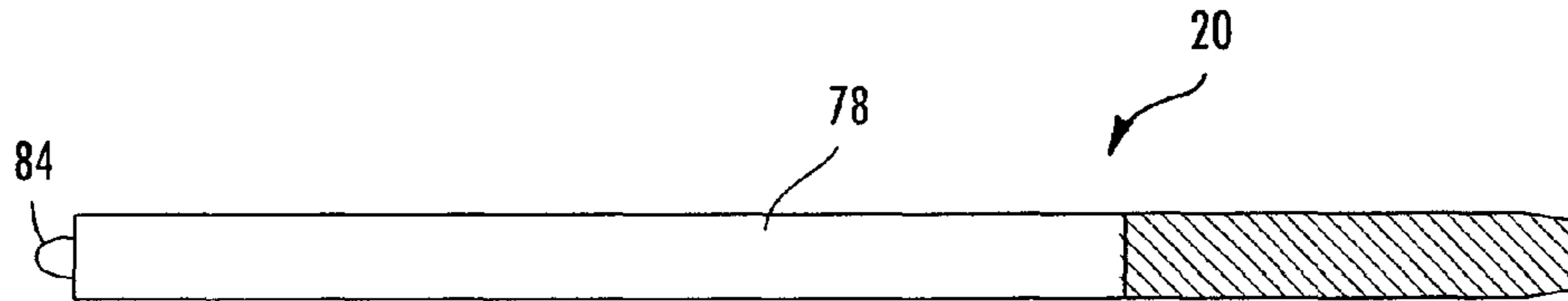

FIG. 7a

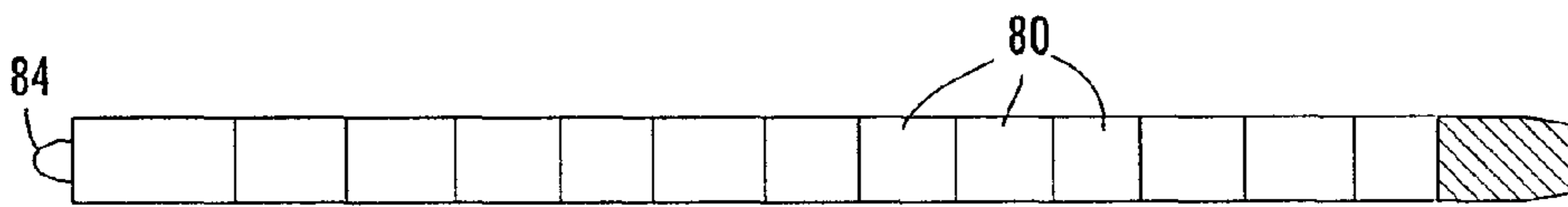

FIG. 7b

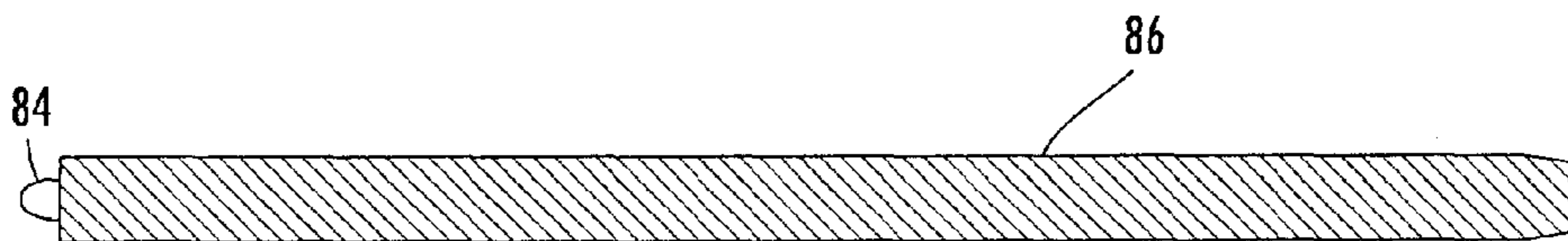

FIG. 7c

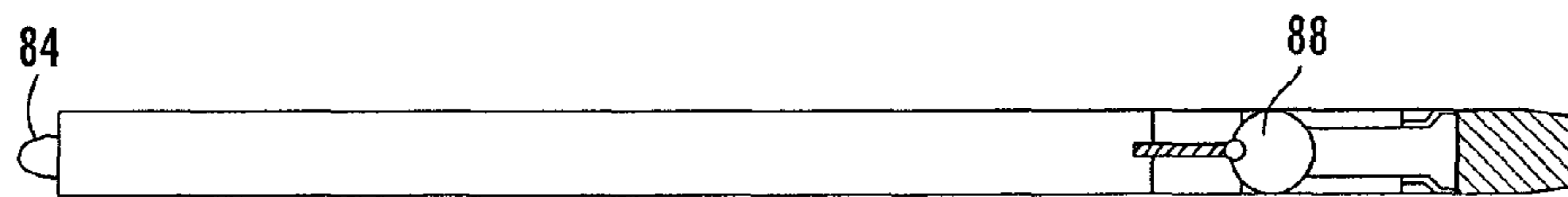

FIG. 7d

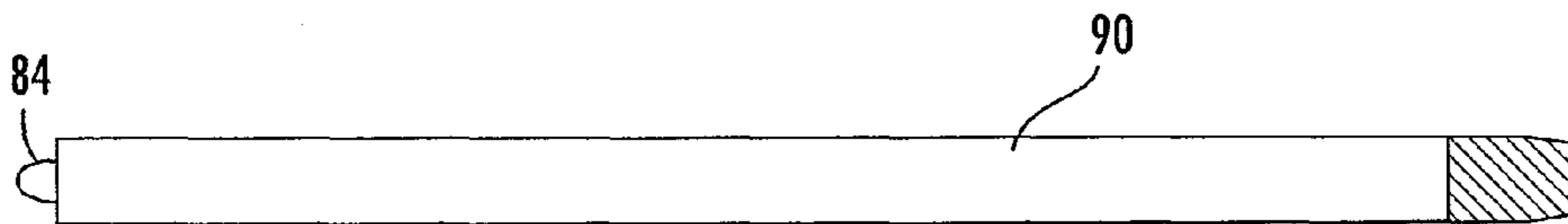

FIG. 7e

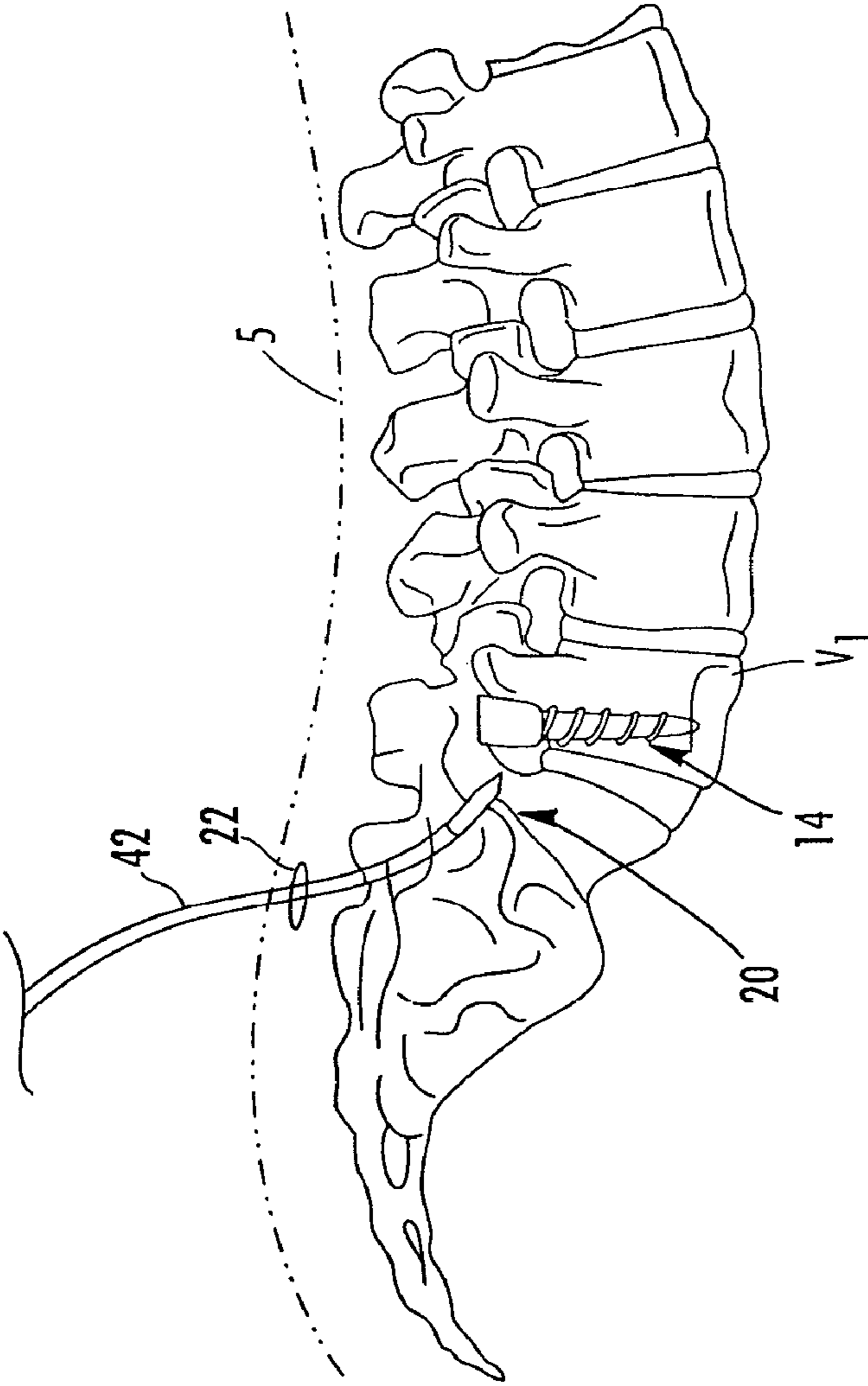

FIG. 8

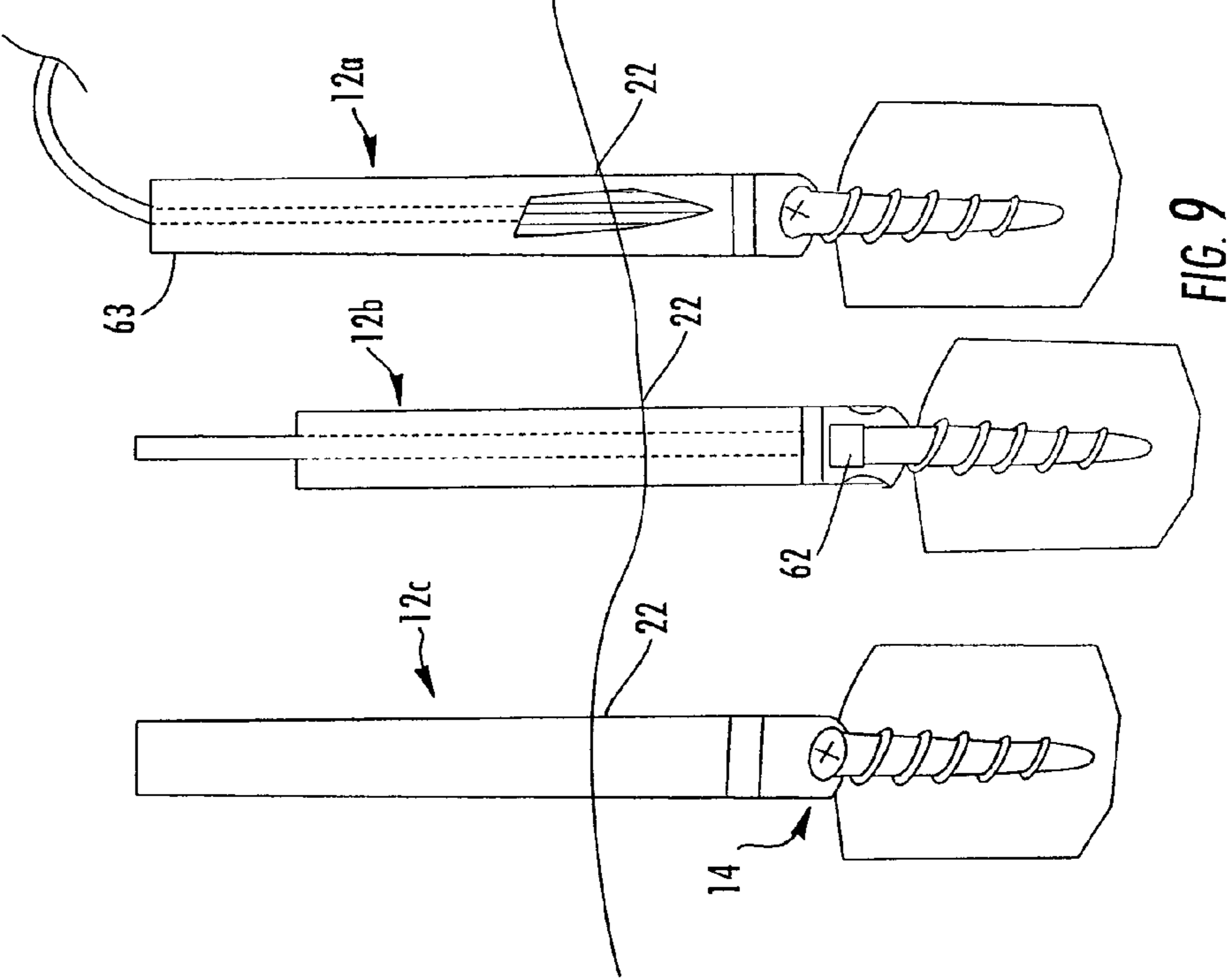

FIG. 9

MAGNETIC TARGETING SYSTEM AND METHOD OF USING THE SAME

Matter enclosed in heavy brackets [] appears in the original patent but forms no part of this reissue specification; matter printed in italics indicates the additions made by reissue; a claim printed with strikethrough indicates that the claim was canceled, disclaimed, or held invalid by a prior post-patent action or proceeding.

RELATED APPLICATIONS

This application is a divisional application of U.S. application Ser. No. 11/462,592, entitled "Magnetic Targeting System and Method of Use", filed Aug. 4, 2006, the contents of which are incorporated herein in their entirety.

FIELD OF THE INVENTION

The invention generally relates to surgical implants; particularly to a system and method for stabilization of adjacent bony structures; most particularly to a system to help navigate an interconnecting means between multiple bony stabilization devices.

BACKGROUND OF THE INVENTION

It is widely held that healing and/or structural correction is greatly facilitated when a bone is stabilized in the proper position. Various devices for stabilization of bone are well known and routinely practiced in the medical arts. For example, an abnormal spine can be stabilized using a substantially rigid or semi-rigid interconnecting means (rod or plate) and fastening means (screws, clamps, hooks, claws, anchors, or bolts). Multiple fasteners are placed into the spinal pedicle of each vertebra and linked by at least one interconnecting means. One of the more difficult aspects is the surgical insertion of the interconnecting means along a fixed path of delivery longitudinally along the vertebrae and through each of the multiple fastening means between multiple vertebrae. Once in place, this system substantially immobilizes the spine and promotes bony fusion (arthrodesis).

Traditionally, the surgical techniques for stabilization of bone required large incisions (upwards of 6 cm in length) and a considerable amount of muscle be cut and stripped away (retracted) from the bone for an "open" visualization of the bone and access thereto for the placement of the fasteners and instrument implantation. Although this so-called "open" surgical technique has successfully treated non-unions, instability, injuries and disease of the spine, it is not without disadvantages. Given the invasive nature of this technique, a lengthy healing time and considerable post-operative pain for the patient is common.

In response to aforementioned drawbacks, the surgical arts have developed minimally invasive systems and procedures intended to replace the more traditional open surgeries. Obviously, a less extensive system and procedure will eliminate the need to perform much of the cutting and stripping of muscle, resulting in reduced recovery time and less post-operative pain. As a result, percutaneous procedures have been developed which insert instruments and perform operations through small skin incisions, usually between 1.5 and 5 cm in length, thereby reducing soft tissue damage. However,

smaller skin incisions and smaller surgical fields require more novel and innovative approaches to perform these complicated surgeries.

One such example of a minimally invasive system is the SEXTANT Spinal system by Medtronic (Memphis, Tenn.). This device is comprised of two basic components, screw extenders, and the rod inserter, which results in an instrument that looks like a sextant used in naval navigation. The device is an insertion tool that allows fasteners and interconnecting means to be applied to the spine in a minimally invasive manner. The screw extenders are long shafts used to deliver and attach screws to the vertebrae through small skin incisions. During surgery, these extenders protrude outside the body, allowing the surgeon to arrange and join their ends so that the rod inserter may be attached. The rod inserter is an arc-shaped arm that swings along a fixed axis and pushes an interconnecting rod through the skin and muscle and into the heads of the implanted fasteners (pedicle screws).

While the aforementioned technique is adequate when the fastening means are well aligned, it fails to deliver the rod when one of the screws is misaligned. Moreover, the interconnecting rod must be pushed by the surgeon along a fixed arch and cannot be directed around neural structures or bony obstructions. One consequence of forcibly pushing the rod through the fastening means is the possibility of colliding the rod with a bony obstruction causing a piece of bone to break off resulting in possible neurological damage. Another common problem is the interconnecting rod becoming disengaged from the rod inserter. When either of these incidents happen, additional surgery is often required to remove the bone fragment and rod from the wound. This may result in the surgeon abandoning the minimally invasive approach and reverting to a traditional approach. Current spinal implant systems do not allow the contour of the rod to match the normal curvature of the surrounding anatomy and such systems are not customizable to meet the individual anatomical variables that each patient presents.

In order to help avoid damaging sensitive anatomy and expedite implant assembly, various image-based navigation systems have been employed which utilize patient images obtained prior to or during the medical procedure to guide a surgeon during the surgery. Recent advances in imaging technology have produced detailed two and three dimensional images using optically guided, fluoroscopic guided, and electromagnetic field based systems. These image-based systems have also been used in combination with the previously described "open" surgeries. One significant problem with most image-based systems is that the radiation generated is transmitted to the patient and surgical staff, which may result in physiological damage over time. Also, the cost and portability of this equipment continue to be an issue. In addition, these systems often require the surgeon undergo extensive training to operate correctly.

Accordingly, a need exists in the surgical arts for a system and minimally invasive procedure capable of providing optimal mechanical support and bony fusion, while reducing the likelihood of bone damage and neural functioning when compared to the currently available interconnecting elements. It is also desirable to provide a surgical procedure that can be performed in conjunction with, but does not require, an image-based tracking system.

PRIOR ART

Although there are numerous patents directed to systems and methods for insertion of a stabilizing implant at a selected area of an anatomy, the prior art nevertheless fails to teach a

targeting system for the insertion of an implant using minimally invasive techniques having a decreased risk of causing damage to neural structures or bony obstructions using minimal, if any, radiation exposure to the patient and/or surgeon.

For example, U.S. Publication No. 2005/0085714 to Foley et al., discloses a method and apparatus for percutaneous and/or minimally invasive implantation of a construct (e.g., spinal implant). The construct may be implanted using a navigation system for planning and execution of a procedure. A plurality of portions of the construct may be interconnected using locations and paths determined and navigated with the navigation system. The navigation system utilizes optical or electromagnetic localization to determine the precise location of a selected implant construct or instrument. An optical localizer can be positioned relative to an extender attached to a screw. Alternatively, a coil may be positioned in an electromagnetic (EM) field such that the position of the coil may be determined by sensing the induced voltage. A computer is used to form a plan prior to implantation of the construct and thereafter track the various portions of the construct during insertion. The plan and the tracking of the surgery are displayed on a monitor to provide guidance to the surgeon.

U.S. Publication No. 2005/0277934 to Vardiman, discloses a minimally invasive spinal fixation system used for spinal arthrodesis (bony fusion) or motion preservation. The system comprises a plurality of pedicle screws, including a first screw placed into a first vertebral body, and a second screw placed into a second vertebral body, a connector for attaching to the first and second screws and, a removable guide for percutaneously attaching the connector to the first and second screws. According to one embodiment, detectional spheres are positioned on the head of screw extenders and on the handle of the rod insertion tool. A comparator calculates the relative position of the insertion tool handle with respect to the screw extenders and provides a visual display for the surgeon.

U.S. Pat. No. 6,236,875 to Bucholz, discloses surgical navigation systems including reference and localization frames. The system generates an image representing the position of one or more body elements during the procedure using magnetic resonance imaging (hereinafter, MRI) or computed tomography (hereinafter, CT) scan images taken prior to the surgery. The body elements and their relative position are identified during the procedure. The position of the known body elements can then be manipulated using a computer to the relative position of the patient during the surgery. The manipulated data can then be utilized to guide the surgeon for implantation.

U.S. Pat. No. 6,226,548 to Foley et al., discloses an apparatus and procedures for percutaneous placement of surgical implants and instruments such as, for example, screws, rods, wires and plates into various body parts using image guided surgery. The invention includes an apparatus for use with a surgical navigation system, an attaching device rigidly connected to a body part, such as the spinous process of a vertebra, with an identification superstructure rigidly but removably connected to the attaching device. This identification superstructure, for example, is a reference arc and fiducial array which accomplishes the function of identifying the location of the superstructure, and, therefore, the body part to which it is fixed, during imaging by CT scan or MRI, and later during medical procedures. The system utilizes emitters such as light emitting diodes (hereinafter, LEDs), passive reflective spheres, acoustics, magnetics, electromagnetics, radiologic, or micro-pulsed radars for indicating the location of a body part to which the emitter is attached.

U.S. Pat. No. 7,011,660 to Sherman et al., discloses a brace installation instrument and method for the stabilization of bony structures. The installation instrument is sextant-type tool with anchor extensions coupled to the anchors. The instrument is movable with respect to the anchors to position a brace in a position proximate to the anchors. The brace can be indexed for insertion at a predetermined orientation with respect to the installation instrument.

All of the aforementioned prior art disclose a system which utilize an implant insertion means to forcibly push the surgical implant or instruments to the target area in vivo. This increases the possibility of pathway divergence and/or damage to neural and vascular structures. What has been heretofore lacking in the prior art is a simple and economical system and procedure for the accurate and precise placement of surgical implants and/or instruments at a target area while providing a decreased risk to neural and vascular structures. Moreover, none of the aforementioned references provide audible and/or tactile feedback to the surgeon that indicate the target area has been reached.

SUMMARY OF THE INVENTION

The instant invention is related to a magnetic targeting system suitable for guiding a biocompatible device, (implant, surgical instrument) to a target area within the body (in vivo), be it a tumor or implantation point for a fastening means. The system includes a targeting member that includes a steering material. The targeting member is attached at one end to the biocompatible device. The system also includes at least one anchoring member constructed and arranged to secure to a target area in vivo at one end and the other end constructed and arranged for inclusion of a magnetic material effective for influencing the traversal of the steering material in vivo. The magnetically influenced anchoring member interacts with the steering material of the targeting member such that the connected biocompatible device is positionable relative to the target area.

It therefore an objective of the instant invention to provide a system that minimizes soft tissue damage and provides less post-operative pain.

It is a further objective of the instant invention to provide a targeting system that provides real time targeting by providing feedback as to the position of the biocompatible device.

Yet another objective of the present invention is to disclose a feedback system that utilizes audio and/or tactile feedback to indicate to the surgeon when the target area is reached.

Another objective of the present invention is to provide a magnetic targeting system that can penetrate tissue without being distorted or causing physiologic damage, unlike x-rays.

Still a further objective of the invention is to teach a targeting system which allows for shorter surgery, decreased x-ray exposure, and fewer complications for the patient.

Yet another objective of the instant invention is to provide a targeting system that is simple to operate to reduce the training the surgeon must undergo for operation of peripheral systems.

These and other objectives and advantages of this invention will become apparent from the following description taken in conjunction with any accompanying drawings wherein are set forth, by way of illustration and example, certain embodiments of this invention. Any drawings contained herein constitute a part of this specification and include exemplary embodiments of the present invention and illustrate various objects and features thereof.

BRIEF DESCRIPTION OF THE FIGURES

FIG. 1 illustrates a partial side view of a portion of a patient's spine which includes magnetic targeting system according to a preferred embodiment of the invention;

FIG. 2 is the magnetic targeting system as shown in FIG. 1, illustrating the targeting member with attached tethering means threaded through an anchor member;

FIG. 3 is the magnetic targeting system shown in FIG. 1, illustrating the targeting member being removed from the interior of the patient through the last extender;

FIG. 4 is the magnetic targeting system as shown in FIG. 1, illustrating the insertion of the biocompatible device between adjacent vertebrae;

FIG. 5 is a partial cross-sectional view of a portion of the extender removably attached to the connector portion of the multi-axial screw in accordance with one embodiment;

FIG. 6 is an upper perspective view of a multi-axial screw that can be used in system of the present invention;

FIGS. 7a thru 7e illustrate various embodiments of the targeting member used in the instant invention;

FIG. 8 is a partial side view of portion of the spine of a patient which includes the magnetic targeting system according to another embodiment illustrating the insertion of the targeting member in vivo without the use of extenders; and

FIG. 9 illustrates a partial side view of a portion of a patient's spine which includes magnetic targeting system according to another embodiment of the invention using a permanent magnet.

DETAILED DESCRIPTION OF THE INVENTION

Detailed embodiments of the instant invention are disclosed herein, however, it is to be understood that the disclosed embodiments are merely exemplary of the invention, which may be embodied in various forms. Therefore, specific functional and structural details disclosed herein are not to be interpreted as limiting, but merely as a basis for the claims and as a representation basis for teaching one skilled in the art to variously employ the present invention in virtually any appropriately detailed structure.

Referring now to FIGS. 1-9 which illustrate the magnetic targeting system 10 of the present invention suitable for facilitating navigation to a target area, wherein like elements are numbered consistently throughout. FIG. 1 shows a plurality of anchoring members 14 (also referred to as fastening means). The anchoring members are depicted here as multi-axial pedicle screws, each removably attached to an extender 12a, 12b, 12c. Each of the extenders 12a, 12b and 12c has an open top and an aperture 30 adjacent a bottom end of each extender, as illustrated in FIGS. 1 and 2. These screws have a proximal end 16 and a distal end 18. The proximal end includes head portion 24 with a tool opening 26 configured to receive a driving tool (not shown). The distal end includes a threaded shank designed to secure to a selected target area located inside the body of a patient (in vivo), shown here as consecutive spinal vertebrae V1, V2, V3. Although the target area is exemplified here as vertebrae in a partial spinal column, the target area may be located anywhere in vivo.

The screw shown here is a multi-axial screw where the proximal end of the screw may include a connector 28 rotatably connected to the head portion 24 of the screw. That is, the connector is capable of 360 degree rotation relative to the threaded shank 27 of the screw along the axis L of the shank and angular motion defined by the angle α (FIG. 5). One example of a suitable multi-axial screw is described in U.S. Pat. No. 5,797,911, herein incorporated by reference.

Although a multi-axis is exemplified herein, it is contemplated that a fixed axis screw may be used. Fixed-axis screws do not include a rotatable connector 28. Other means for anchoring are also contemplated herein, some of which include, clamps, hooks, claws, bolts, or the like. Moreover, the shank of the anchor member may or may not be cannulated, as is known in the art.

As shown in FIGS. 5 and 6, the connector portion of the screw is constructed and arranged to form a passageway 30 designed to removably receive implants of various sizes. The connector portion includes an opening 43 constructed and arranged to receive a set screw 38. As shown in FIG. 6, the head portion includes threaded interior sidewalls 46 designed to mate with external threads 38 formed on the set screw. Thus, as the set screw is threadably lowered along the connector portion of the screw the passageway 30 in the connector is narrowed. The passageway is narrowed until the exterior surfaces of the biocompatible device 44 (shown here as interconnecting rod, see FIGS. 1-4) are sandwiched between the upper portion of the screw head 24 and the set screw. This acts to reliably secure the biocompatible device onto the screw. As with the head of the screw, there should be a tool opening 40 configured to receive a driving tool (not shown) inserted within the interior portion 74 of the extenders. The driving tool is well known in the surgical arts and is used to rotatably secure the set screw to the desired position within the interior of the connector.

As discussed above, the distal end 34 of each of the hollow extenders 12a, 12b, 12c are removably attached to the screws by any appropriate means known in the art. For example, the extender may include a depressible member (not shown) located at the proximal end 33 of the extender that is operatively connected to an internal clamping member located at the distal thereof. The clamping member is capable of engaging and disengaging the connector portion of the screw. One example of a suitable extender which could be used in the present invention is disclosed in U.S. Pat. No. 7,011,660, herein incorporated by reference. The extender may also be able to rotate the connector of a multi-axial screw relative to the shank to facilitate the threading of the interconnecting rod therethrough.

The extenders should be made of a substantially rigid biocompatible material and have a length dimension (along its longitudinal axis 50) that allows the proximal end 33 to protrude a distance outside of the percutaneous exposure 22 created through the outer skin S of the patient. According to a preferred embodiment, at least the first extender should have a "c-shape", as seen along an axis transverse its longitudinal axis, thereby defining a slot 63 that extends along its longitudinal axis 50 and into the patient when attached to the screw. The slot should be sized to allow the targeting member to exit, so that it is able to be delivered percutaneously, as shown in FIG. 1. The interior dimension 76 of the extenders should be such that they are capable of receiving the appropriate driving tool (not shown) used to engage the screws and set screws. In addition, the interior dimension of the extenders should be able to accept a removable magnetic device 60 for magnetically influencing the anchor members 14, as described further below.

Referring again to FIGS. 1-4, a targeting member is shown attached to biocompatible device 44 by a tethering means 42. The targeting member has a first end 52 and a second end 54. The first end is designed to penetrate the tissue and is shaped to enlarge the opening while creating a pathway through the tissues as the targeting member is advanced in vivo. At least

the first end of the targeting member is composed of a steering material capable of being magnetically influenced, as described hereafter.

As shown in non-limiting embodiments of FIGS. 7a-e, the targeting member **20** may be made from a flexible, semi-rigid, or rigid material, each includes the steering material **84** located on the first end. FIG. 7a illustrates an embodiment of a semi-rigid targeting member in the form of rod-like member with steering material **84** disposed on its first end **52**. The first portion **78** of the rod is made of a flexible material capable of safely colliding with bony or neural obstructions without causing damage. FIG. 7b illustrates another flexible rod formed of a plurality of rigid consecutive segments **80** through which the tethering means **42** extends to the first end (not shown). When the surgeon pulls the tethering member at the second end taut, the segments are forced together and little movement is permitted between the segments. In the embodiment of FIG. 7c, the entire targeting member is composed of or coated with a second biocompatible steering material **86**. FIG. 7d illustrates another embodiment wherein the targeting member includes a ball joint **88** attached to the tethering means. As with the embodiment of FIG. 7b, the tension in the tethering member controls the amount of pivot at the ball joint. Thus, when tension is released the rod comes flexible and the first end of the targeting member pivots on the ball. Alternatively, when the tension is reapplied to the tethering means, the rod is solid again. This way the surgeon is able to safely guide the targeting member around neural and bony obstructions as it moves through the body. Lastly, FIG. 7e depicts a rigid rod-like member formed from a solid biocompatible material **90**.

The tethering means **42** may be made of any flexible or semi-flexible biocompatible material capable of allowing the device to navigate around neural and bony obstructions without damaging them. Examples of suitable tethering means may be in the form of a cable, cord or ligament. Moreover, the tethering means may be formed of a cannulated or solid member. As discussed above, the first end **92** of the tethering means is attached to the second end **54** of the targeting member by any means of attachment known in the art. Similarly, the second end **94** of the tethering means is attached to the biocompatible device **44** by any means of removable connection known in the art. For example, the biocompatible device and tethering means could include corresponding threads that the surgeon can rotate to disconnect the tethering means from the biocompatible device.

According to a preferred embodiment, the biocompatible device is shown as an implantable interconnecting rod. The rod may be rigid, semi-rigid or flexible. Rigid rods are usually preferred for providing the necessary stability during the healing process and arthrodesis, however, flexible rods have been found to provide for arthrodesis while allowing some movement between bony structures that have been interconnected to preserve some motion. Moreover, like the tethering means the biocompatible device may also be solid or cannulated.

Although the interconnecting rod is shown in FIGS. 1-4 as interconnecting two pedicle screws, the surgeon could use any appropriately sized rod having a length dimension capable of interconnecting three or more fastening means co-linearly implanted along multiple vertebrae. It is also within in the purview of the invention that any sized rod having various widths or diameters could be used so long as it is capable of stabilizing the bony structures for bony fusion. Although a rod-like member is exemplified herein, other such biocompatible devices known to one skilled in the art are also contemplated, for example, plates, clamps, etc.

FIG. 4 illustrates a hollow or cannulated flexible biocompatible device in fluid communication with a cannulated tethering means. According to this embodiment, once the rod has been properly inserted into the desired location, the surgeon can use an insertion means **96** (syringe or the like) to supply a biocompatible hardening material (e.g., cement, carbon, bone matrix) through the tethering means and into the interior of the hollow rod. Although not required, the biocompatible device might also be made permeable and used to deliver constituents supplied by the insertion means to the target area (e.g., bone growth/fusion material, medication, curing material, etc.).

As shown in FIGS. 1-4, each of the proximal ends of the extenders **12a-c** protrude outside of the patient's skin through percutaneous incisions **22** so that the surgeon is able to insert instrumentation through the extender's interior portion to access the screw secured to the target area (vertebra). The extenders also enable the surgeon to insert the magnetic device or wand **60** into the selected extender to a position proximate the corresponding anchor **14**. The magnetic device includes a proximal **64** and a distal end **66**. Magnetic material **62** is attached at the distal end of the device and the proximal end may include a grip **100** (not required) for the surgeon to hold the magnetic device. The wand should be sized to extend the length of the extender.

The "magnetic material" **62** as used herein refers to either a permanent magnet (as shown in FIG. 9) or an electromagnet (shown in FIGS. 1-4) which generates a magnetic field capable of influencing the steering material in the targeting member in vivo. As is known in the art, an electromagnet is a magnet in which the magnetic field is produced by a flow of electrical current. One example of a suitable permanent magnet is a Neodymium Iron Boron (NdFeB) magnet since it is powerful and has been approved by the U.S. Food and Drug Administration (FDA) for internal use. Another example is the use of a recently developed biocompatible non-metallic magnet, or plastic magnet, made from the polymer PANiCNQ which is combination of emeraldine-base polyaniline (PANi) and tetracyanquinodimethane (TCNQ).

The "steering" material in the target member, as used herein, refers to any material capable of being influenced by the magnetic material **62**. For example, the steering material may include any magnetically attractive material or alloy, (e.g. steel, iron, etc). The steering material may be the same or different than that used for magnetic material **62** so long as it is capable of being influenced, e.g., attracted or repelled. Moreover, either or both the magnetic material and the steering material may be coated with any suitable biocompatible element, such as plastic. The type, shape, and size of the magnetic material and steering material should be suitable for internal use in patients and provide the optimal magnetic field. Magnetic fields are used herein for navigating in vivo since these fields can penetrate human tissue and bone without being distorted similar to x-rays, but without the danger of radiation and physiologic damage.

According to a preferred embodiment shown in FIGS. 1-4, the magnetic material employs an electromagnet having controls located in the handle or grip **100**. At a minimum, the controls should include buttons and associated circuitry that will allow the surgeon to turn the electromagnet on **102** and off **104**. Preferably, the controls also include buttons and circuitry capable of increasing **106** or decreasing **108** the strength of the magnetic field generated by the electromagnet and/or switch between polarity (north and south poles). As is known, the polarity of a magnet allows it to attract or repel

magnetic material within its magnetic field. The controls can also include a display **110** used to indicate the strength of the magnetic field being applied.

The method of using the magnetic targeting system **10** of the present invention is described in accordance with the embodiment depicted in FIGS. **1-4**. First, the anchoring member **14** (shown here as the multi-axial pedicle screw) is inserted into the desired target area (shown here as vertebra), as is known in the surgical art. The screw may be removably attached to the distal end of the extender before or after attachment of the screw to the selected vertebrae. Once attached, the surgeon inserts the targeting member into the proximal end of the extender which protrudes outside of the percutaneous exposure **22**. The magnetic device is inserted into the next vertebra **V2** which includes the anchoring member (extender and screw), shown here as **12b**. The magnetic material **62** is disposed proximate the target area via wand **60**. According to this example, the magnetic material is placed inside the connector portion of the screw, this may be done prior to, during, or after the targeting member is inserted into the extender. If an electromagnet is used, the surgeon will switch on the electrical current to begin generating an attractive magnetic field when in the proper position in vivo. If a permanent magnetic is used for the magnetic material **62**, the surgeon simply places it inside the connector portion of the screw, see FIG. **9**.

As a result of the attractive magnetic field, the steering material in the targeting member is pulled through the extender slot **63**. The strength of the magnetic field generated by the magnetic material should be capable of pulling the targeting member (including attached tethering mean) toward the magnetic member such that the pointed first end penetrates the tissue and creates a pathway through the tissues as the targeting member is advanced toward the magnetic material. The use of the magnetic field to guide the targeting member, as compared to forcibly pushing the targeting member, as disclosed in the prior art, reduces the probability of damaging neural structures or breaking bony obstructions encountered along its path.

Once the targeting member has reached the magnetic material **62** positioned inside the connector portion of the screw, the surgeon removes it from the anchoring member and places it into the next anchoring member (extender and screw), shown here as **12c** attached to vertebra **V3**. The aforementioned procedure is then repeated inside anchoring member **12c**. If an electromagnet is used, the electricity along the magnetic member is turned on and the strength of the magnetic field generated pulls the targeting member through the passageway **30** of the screw secured to **V2** and toward the magnetic member located inside the screw secured to **V3**, see FIG. **2**. If a permanent magnet is used, the surgeons simply places the distal end inside the connector portion of the anchor.

As described before, the pointed first end of the target member penetrates the tissue and creates a pathway through the tissues as it moves toward the magnetic material. This technique of threading through the screw does not require the surgeon to try to align multiple pedicle screws along the fixed path of the rod. Moreover, the continuous magnetic attraction of the targeting member toward the pedicle screw reduces the possibility that the target member will be diverted by structures in the anatomical topography that may cause it to penetrate unintended areas. In addition, the present invention allows the surgeon to avoid a given anchor member. In such a circumstance the surgeon can insert the magnetic material into that extender connected to the anchor member that is to be avoided. The magnetic material may be either a permanent

magnet or electromagnet having the same polarity as that of the targeting member. This will repel the steering material of the target member from that target area.

Once the final vertebra is reached, the magnetic member is used to pull the targeting member through the slot in the upper opening **43** of the pedicle screw and along the interior length of the extender until it reaches the proximal end protruding out of the incision. The surgeon can then grasp the targeting member and attached tethering means, see FIG. **3**. The tethering means located outside the patient is then used by the surgeon to gently pull the attached biocompatible member (rod) along the path formed through the tissue by the targeting member and through the connector portion of the pedicle(s) until the biocompatible member reaches the last vertebra, as shown in FIG. **4**.

If the tethering means and interconnecting rod are hollow, the user can disconnect the targeting member and releasably attach an injection means **96** thereto. The injecting means can be used into supply any suitable any flowable, biocompatible material inside the rod. One example of a suitable biocompatible material includes at least one a hardening material that will cause the rod to become rigid.

Otherwise, the rod might be filled prior to the introduction of a hardening material. For example, the rod might contain ferroelectric material that allows the rod to remain flexible during insertion process until exposed to an electric current. This is particularly suitable if used in conjunction with the electromagnet embodiment previously described. Once the flexible rod is positioned at the final desired location (secured to pedicle screws), the rod may then be exposed to electric current in the electromagnet by inserting the magnetic means into the extenders. The electric current causes the ferroelectric material to harden to make a substantially rigid rod. Thus, the contour of the rod corresponds to the natural curvature of the surrounding anatomy.

As discussed above, the connector portion of the screw is constructed and arranged to receive a set screw **32** therein. The set screw is inserted into each of the extenders and threadably attached by the driving tool (not shown) positioned in the extender and inserted in tool opening in the screw. The interconnecting rod **44** is sandwiched between the upper portion of the head and the set screw. This acts to secure the rod onto the screws. The extenders are then removed from the connector portion of the screw and the exposures closed.

Referring to an alternative embodiment shown in FIG. **8**, the targeting system of the present invention does not require the use of an extension member for insertion of the targeting member in vivo. The anchoring member may be implanted and the exposure closed with no external access thereto. The proximal end of the implanted anchoring member may include either a permanent magnet or a remotely controlled electromagnet, as is known in the art. Thus, the targeting member **20** may be directly inserted and fed into the body through an incision created by the surgeon. As with the previous embodiments, the magnetic portion of the anchoring member is capable of attracting or repelling the targeting member placed inside the patient.

Any of the aforementioned embodiments of the system and techniques of the present invention can employ any type of known imaging system to determine and locate placement of any of the aforementioned structures in vivo. For example, insertion of the anchor member into the bony structure can be pre-planned by CT scan, x-ray, or the imaging means known in the art.

The present system may also include a feedback system having at least one detection element **120** (two are shown in FIG. **1**) disposed outside and proximate the patient to deter-

mine the position of the targeting member and/or biocompatible member in real-time. According to one, albeit non-limiting embodiment, the detection element is an audio receiver or pickup capable of audibly detecting when the targeting member and magnetic means connect or “click” together. This way, the surgeon can imagelessly determine that the targeting member has reached the magnetized portion of the anchoring member. This may be used in conjunction with a tactile sensation produced when the targeting member and magnetic means connect. This tactile sensation of the two elements meeting will be felt by the person holding the tethering means.

Although the invention is described with reference to stabilization and fusion of adjacent spinal vertebrae, it is hereby contemplated that devices and methods disclosed herein could be used in all types of joints (ankle, interdigital, etc) found in the human or animal body. Although a rod-like member is exemplified herein, other such biocompatible devices known to one skilled in the art are also contemplated, for example, plates, clamps, etc.

All patents and publications mentioned in this specification are indicative of the levels of those skilled in the art to which the invention pertains. All patents and publications are herein incorporated by reference to the same extent as if each individual publication was specifically and individually indicated to be incorporated by reference.

It is to be understood that while a certain form of the invention is illustrated, it is not to be limited to the specific form or arrangement herein described and shown. It will be apparent to those skilled in the art that various changes may be made without departing from the scope of the invention and the invention is not to be considered limited to what is shown and described in the specification and any drawings/figures included herein.

One skilled in the art will readily appreciate that the present invention is well adapted to carry out the objectives and obtain the ends and advantages mentioned, as well as those inherent therein. The embodiments, methods, procedures and techniques described herein are presently representative of the preferred embodiments, are intended to be exemplary and are not intended as limitations on the scope. Changes therein and other uses will occur to those skilled in the art which are encompassed within the spirit of the invention and are defined by the scope of the appended claims. Although the invention has been described in connection with specific preferred embodiments, it should be understood that the invention as claimed should not be unduly limited to such specific embodiments. Indeed, various modifications of the described modes for carrying out the invention which are obvious to those skilled in the art are intended to be within the scope of the following claims.

What is claimed is:

1. A method for facilitating navigation to a target area in vivo, comprising: providing a targeting member having a first end and a second end, said second end attached to a biocompatible device by a tether, wherein said first end includes a steering material influenced by a magnetic field; attaching to said target area in vivo at least two anchoring members, each said anchoring member having a proximal end and a distal end, wherein each said anchoring member is attached to said target area at its distal end; an extender coupled to each said anchoring member, said extender having an open top at said proximal end and an aperture juxtaposed to a bottom of said extender at said distal end; introducing a magnetic material into said proximal end of said anchoring member capable of influencing the traversal of said steering material, thereby positioning said biocompatible device relative to said target

area; said targeting member is of a size which enables said targeting member to pass into said extender through said top of said extender, through said extender and out of said extender through said aperture of said extender, said targeting member is also of a size which enables said targeting member to pass into said extender through said aperture, through said extender and out of said extender through said open top; passing said targeting member through said open top of first extender, through said first extender and out of said first extender through said aperture of said first extender, also passing said targeting member into second extender through said aperture, through said second extender and out of said second extender through said open top of said second extender.

2. The method as set forth in claim 1, wherein said system includes a real-time feedback mechanism to verify location in vivo of said biocompatible device.

3. The method as set forth in claim 2, wherein said real-time feedback mechanism includes tactile feedback to verify location in vivo of said biocompatible device.

4. The method as set forth in claim 1, wherein said magnetic material is an electromagnet.

5. The method as set forth in claim 1, wherein said magnetic material is a permanent magnet.

6. The method as set forth in claim 1 wherein said biocompatible device is an implant or surgical instrument.

7. The method as set forth in claim 1 wherein said biocompatible device is formed from a material selected from the group consisting of rigid, semi-rigid, or flexible.

8. The method as set forth in claim 1, wherein said anchor member is a fastening means for attaching to a bony structure and said biocompatible device is an interconnecting means.

9. The method as set forth in claim 1, wherein said targeting member is formed from a material selected from the group consisting of rigid, semi-rigid, or flexible.

10. A method for facilitating navigation of a biocompatible device to a target position connecting anchoring members secured in vivo, comprising:

securing first and second anchor members to a body structure located in vivo, said first and second anchoring members each having a distal end configured to secure to a body structure located in vivo and a proximal end including a connector with a transverse passage configured to receive a portion of a biocompatible device, the first connector releasably coupled to a first extender and the second connector releasably coupled to a second extender, each of said first extender and said second extender having an open top that opens into an interior passage extending between a proximal end and distal end and an aperture adjacent the distal end that extends transversely through the interior passage;

advancing a targeting member to a first position within the interior passage of the first extender proximate the aperture, the targeting member having a first end and a second end, said second end attached to the biocompatible device by a tether and said first end including a steering material configured to be influenced by a magnetic field;

positioning the distal end of a magnetic device in a second position within the interior passage of the second extender proximate the aperture, the distal end of the magnetic device including a magnetic material configured to influence the steering material of the targeting member, and influencing the targeting member to move from the first position to the second position thereby creating a pathway through the tissue between the first connector and the second connector;

13

withdrawing the targeting member through the interior passage of the second extender to pull the attached biocompatible device along the pathway into the target position connecting the first and second anchor members.

11. The method of claim 10, wherein said magnetic material is an electromagnet and including the additional step of turning on the electromagnet after the distal end of the magnetic device is situated in the second position.

12. The method of claim 11, wherein the magnetic device includes a handle at a proximal end and the handle includes a switch for turning on the electromagnet.

13. The method of claim 12, wherein the handle also includes controls for increasing and decreasing the strength of the electromagnet.

14. The method of claim 10, wherein the magnetic material is a permanent magnet.

15. The method of claim 10, wherein the targeting member is semi-rigid with a portion of the targeting member proximate the first end being made of flexible material.

16. The method of claim 10, wherein the targeting member is rigid.

17. The method of claim 10, wherein the first and second anchoring members are pedicle screws and the step of securing the first and second anchor members to a body structure located in vivo include securing the first pedicle screw to a first vertebra of the spine and securing the second pedicle screw to a second vertebra of the spine.

18. The method of claim 17, wherein the first and second pedicle screws are multi-axis pedicle screws.

19. A method for facilitating navigation of a biocompatible device to a target position connecting anchoring members secured in vivo, comprising:

securing anchor members to a body structure located in vivo, said anchor members including a first end anchor member, a second end anchor member, a middle anchor member, each of the first end anchor member, second end anchor member, and middle anchor member, each anchor member having a proximal end including a connector with a transverse passage configured to receive a portion of a biocompatible device, the connector of the first end anchor member being releasably coupled to a first end extender, and connector of the second end

14

anchor member releasably coupled to a second end extender, and the connector of the middle anchor member releasably connected to middle extender, each of said first end extender, second end extender, and middle extender having an open top that opens into an interior passage extending between a proximal end and distal end and an aperture adjacent the distal end that extends transversely through the interior passage;

advancing a targeting member to a first position within the interior passage of the first end extender proximate the aperture, the targeting member having a first end and a second end, said second end attached to the biocompatible device by a tether and said first end including a steering material configured to be influenced by a magnetic field;

positioning the distal end of a magnetic device in a second position within the interior passage of the middle extender proximate the aperture, the distal end of the magnetic device including a magnetic material configured to influence the steering material of the targeting member, and influencing the targeting member to move from the first position to the second position thereby creating a pathway through the tissue between the first end connector and the middle connector;

positioning the distal end of the magnetic device in a third position within the interior passage of the second end extender proximate the aperture and influencing the targeting member to move from the second position to the third position thereby extending the pathway through tissue to the second end connector

withdrawing the targeting member through the interior passage of the second end extender to pull the attached biocompatible device along the pathway into the target position connecting the first end anchor member, middle anchor member, and second end anchor member.

20. The method of claim 19, further comprising multiple middle anchor members secured between the first end anchor member and the second end anchor member, each include a releasably coupled middle extender and wherein the magnetic device is used through each additional middle extender in sequence to move the targeting member to the coupled middle connector from the previous middle connector.

* * * * *

UNITED STATES PATENT AND TRADEMARK OFFICE
CERTIFICATE OF CORRECTION

PATENT NO. : RE45,659 E
APPLICATION NO. : 14/152987
DATED : September 1, 2015
INVENTOR(S) : Geist et al.

Page 1 of 1

It is certified that error appears in the above-identified patent and that said Letters Patent is hereby corrected as shown below:

In the Specification

Please insert Line 11 (approx.) of Column 1 as follows:

--Notice: More than one reissue application has been filed for the reissue of U.S. Patent No. 8,092,460. The reissue applications are U.S. Reissue Patent Application Serial No. 14/842,745, filed on September 1, 2015, now U.S. Reissue Patent No. RE46,282 E, issued January 24, 2017, which is a continuation reissue application of U.S. Reissue Patent Application Serial No. 14/152,987 (the present application), filed on January 10, 2014, now U.S. Reissue Patent No. RE45,659 E, issued September 1, 2015.--

Signed and Sealed this
Twelfth Day of June, 2018

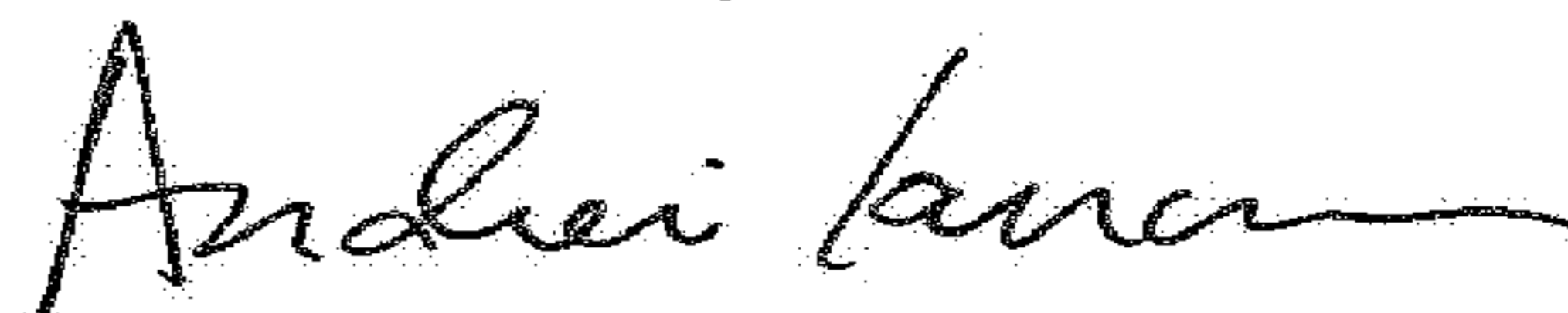

Andrei Iancu
Director of the United States Patent and Trademark Office