



US00RE45639E

(19) **United States**  
(12) **Reissued Patent**  
**Fraser et al.**

(10) **Patent Number:** **US RE45,639 E**  
(45) **Date of Reissued Patent:** **Aug. 4, 2015**

(54) **MEDICAL INSTALLATION TOOL**  
(71) Applicant: **DePuy Synthes Products, LLC**,  
Raynham, MA (US)  
(72) Inventors: **Robert D. Fraser**, Adelaide (AU);  
**Alexander Grinberg**, Newton, MA  
(US); **John D. Malone**, Franklin, MA  
(US); **Bradley Moore**, West Vancouver  
(CA); **Michael J. O'Neil**, West  
Barnstable, MA (US); **Mark C. Boomer**,  
Phoenix, AZ (US)

(73) Assignee: **DePuy Synthes Products, Inc.**,  
Raynham, MA (US)

(21) Appl. No.: **14/172,631**

(22) Filed: **Feb. 4, 2014**

**Related U.S. Patent Documents**

Reissue of:

(64) Patent No.: **6,755,841**  
Issued: **Jun. 29, 2004**  
Appl. No.: **10/011,264**  
Filed: **Dec. 7, 2001**

U.S. Applications:

(63) Continuation-in-part of application No. 09/566,514,  
filed on May 8, 2000, now Pat. No. 6,478,800, which is  
an application for the reissue of Pat. No. Re. 43,317,  
which is an application for the reissue of Pat. No.  
6,755,841.

(51) **Int. Cl.**  
**A61B 17/58** (2006.01)  
**A61F 2/46** (2006.01)

(52) **U.S. Cl.**  
CPC ..... **A61F 2/4611** (2013.01)

(58) **Field of Classification Search**  
CPC ..... **A61F 2/4611**  
USPC ..... **606/99**  
See application file for complete search history.

(56) **References Cited**

U.S. PATENT DOCUMENTS

3,409,013 A 11/1968 Berry  
3,486,505 A \* 12/1969 Morrison ..... 606/90

(Continued)

FOREIGN PATENT DOCUMENTS

DE 29901611 U 4/1999  
DE 29901611 U1 4/1999

(Continued)

OTHER PUBLICATIONS

[No Author Listed] Metronic, "Parallel Tissue Offerings," (2004).

(Continued)

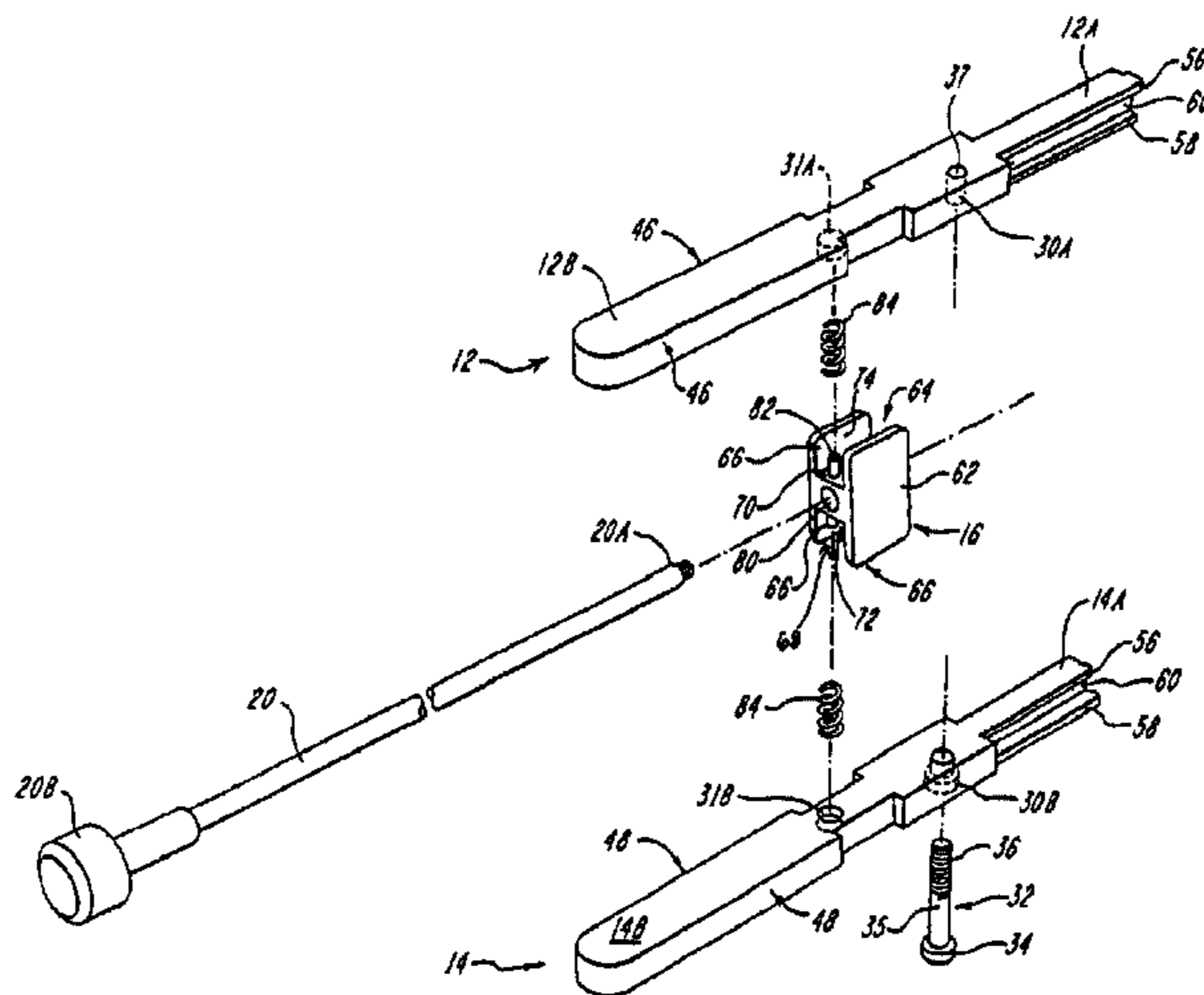
*Primary Examiner* — Nicholas Woodall

(74) *Attorney, Agent, or Firm* — Nutter McClennen & Fish  
LLP

(57) **ABSTRACT**

An installation tool that is useful for the efficient and effective placement of an article, such as an artificial disc, between adjacent vertebral bodies is provided. The installation tool can be provided as a kit having modular components which allow the surgeon to select from among a variety of components to assemble an installation tool that is optimized for its intended use. The installation tool of the invention generally includes a pair of opposed levers, each of which has a proximal handle portion and a distal portion. A fulcrum is disposed between the two levers to enable proper operation of the tool. The tool further includes a pusher block that is positioned between the two levers and is selectively movable between an initial location distal of the fulcrum and a final location adjacent the distal end of the levers. The pusher block includes a proximal end, a distal end, and a bore extending at least partially therethrough. A pusher rod, which facilitates movement of a pusher block, has a distal end extending into the bore in the pusher block and a proximal, handle end.

**16 Claims, 19 Drawing Sheets**



# US RE45,639 E

(56)

## References Cited

### U.S. PATENT DOCUMENTS

4,034,746	A	7/1977	Williams	
4,337,576	A	7/1982	Drost et al.	
4,369,788	A	1/1983	Goald	
4,444,184	A	4/1984	Oretorp	
4,545,374	A *	10/1985	Jacobson	606/61
4,660,287	A	4/1987	Decker	
4,730,613	A	3/1988	Gordy	
4,735,202	A	4/1988	Williams	
4,772,287	A	9/1988	Ray et al.	
4,877,020	A	10/1989	Vich	
4,898,161	A *	2/1990	Grundei	606/105
4,997,432	A	3/1991	Keller	
5,015,247	A	5/1991	Michelson	
5,019,081	A	5/1991	Watanabe	
5,020,519	A *	6/1991	Hayes et al.	128/69
5,052,373	A	10/1991	Michelson	
5,055,104	A	10/1991	Ray	
5,059,194	A	10/1991	Michelson	
5,122,130	A	6/1992	Keller	
5,139,507	A	8/1992	Dolgin et al.	
5,213,112	A	5/1993	Niwa et al.	
5,254,128	A	10/1993	Mesa	
5,292,329	A	3/1994	Werner	
5,304,119	A	4/1994	Balaban et al.	
5,306,309	A	4/1994	Wagner et al.	
5,314,477	A	5/1994	Marnay	
5,403,337	A	4/1995	Platts	
5,423,843	A	6/1995	Werner	
5,431,658	A *	7/1995	Moskovich	606/99
5,431,672	A	7/1995	Cote et al.	
5,443,514	A	8/1995	Steffee	
5,481,804	A	1/1996	Platts	
5,484,437	A	1/1996	Michelson	
5,496,340	A	3/1996	Abidin et al.	
5,505,732	A	4/1996	Michelson	
5,531,754	A	7/1996	Shackelford, Sr. et al.	
5,562,736	A	10/1996	Ray et al.	
5,569,281	A	10/1996	Abidin et al.	
5,569,282	A	10/1996	Werner	
5,571,109	A	11/1996	Bertagnoli	
5,599,351	A	2/1997	Haber et al.	
5,620,454	A	4/1997	Pierce et al.	
5,645,597	A	7/1997	Krapiva	
5,665,099	A	9/1997	Pilo et al.	
5,683,407	A	11/1997	Jolly et al.	
5,683,464	A	11/1997	Wagner et al.	
5,720,751	A	2/1998	Jackson	
5,722,977	A	3/1998	Wilhelmy	
5,730,751	A	3/1998	Dillon et al.	
5,741,253	A	4/1998	Michelson	
5,752,968	A	5/1998	Jolly et al.	
5,766,252	A	6/1998	Henry et al.	
5,779,724	A	7/1998	Werner	
5,782,830	A	7/1998	Farris	
5,792,162	A	8/1998	Jolly et al.	
5,797,909	A	8/1998	Michelson	
5,800,438	A *	9/1998	Tuke et al.	606/90
5,827,309	A	10/1998	Jolly et al.	
5,868,771	A	2/1999	Herbert et al.	
5,885,299	A	3/1999	Winslow et al.	
5,885,300	A	3/1999	Tokuhashi et al.	
5,888,224	A	3/1999	Beckers et al.	
5,899,901	A	5/1999	Middleton	
5,908,432	A	6/1999	Pan	
5,935,151	A *	8/1999	Broughton et al.	606/241
5,944,658	A	8/1999	Koros et al.	
5,951,564	A *	9/1999	Schroder et al.	606/100
5,957,927	A	9/1999	Magee et al.	
6,004,326	A	12/1999	Castro et al.	
6,015,419	A	1/2000	Strome et al.	
6,022,364	A	2/2000	Flumene et al.	
6,042,582	A	3/2000	Ray	
6,063,088	A	5/2000	Winslow	
6,066,174	A	5/2000	Farris	
6,080,155	A *	6/2000	Michelson	606/61

6,083,225	A	7/2000	Winslow et al.	
6,083,228	A	7/2000	Michelson	
6,096,038	A	8/2000	Michelson	
6,113,602	A *	9/2000	Sand	606/61
6,117,174	A	9/2000	Nolan	
6,133,602	A	10/2000	Shrivastava et al.	
RE37,005	E	12/2000	Michelson et al.	
6,156,040	A	12/2000	Yonemura et al.	
6,159,212	A	12/2000	Schoedinger, III et al.	
6,159,215	A *	12/2000	Urbahns et al.	606/86
6,159,244	A	12/2000	Suddaby	
6,168,601	B1 *	1/2001	Martini	606/90
6,197,033	B1	3/2001	Haid, Jr. et al.	
6,200,322	B1	3/2001	Branch et al.	
6,261,296	B1	7/2001	Aebi et al.	
6,267,763	B1	7/2001	Castro	
6,277,122	B1	8/2001	McGahan	
6,319,257	B1 *	11/2001	Carignan et al.	606/99
6,436,119	B1	8/2002	Erb et al.	
6,440,142	B1	8/2002	Ralph et al.	
6,478,800	B1 *	11/2002	Fraser et al.	606/99
6,520,967	B1	2/2003	Cauthen	
6,551,316	B1	4/2003	Rinner et al.	
6,575,981	B1	6/2003	Boyd et al.	
6,582,437	B2	6/2003	Dorchak et al.	
6,589,247	B2	7/2003	McGahan et al.	
6,599,291	B1	7/2003	Foley et al.	
6,599,294	B2	7/2003	Fuss et al.	
6,648,888	B1	11/2003	Shluzas	
6,648,895	B2	11/2003	Burkus et al.	
6,663,638	B2	12/2003	Ralph	
6,712,825	B2	3/2004	Aebi et al.	
6,719,760	B2	4/2004	Dorchak et al.	
6,743,234	B2	6/2004	Burkus et al.	
6,755,841	B2	6/2004	Fraser et al.	
6,814,737	B2	11/2004	Cauthen	
7,118,580	B1	10/2006	Beyersdorff et al.	
RE43,317	E	4/2012	Fraser et al.	
RE44,835	E	4/2014	Fraser et al.	
2001/0029377	A1	10/2001	Aebi et al.	
2001/0031968	A1	10/2001	Dorchak et al.	
2001/0031969	A1	10/2001	Aebi et al.	
2002/0116009	A1	8/2002	Fraser et al.	
2002/0123754	A1	9/2002	Holmes et al.	
2002/0143343	A1	10/2002	Castro	
2002/0198532	A1	12/2002	Michelson	
2003/0069586	A1	4/2003	Errico et al.	
2003/0078590	A1	4/2003	Errico et al.	
2003/0149438	A1	8/2003	Nichols et al.	
2003/0212404	A1	11/2003	Dorchak et al.	
2003/0225416	A1	12/2003	Bonvallet et al.	
2004/0039397	A1	2/2004	Weber et al.	
2004/0078079	A1	4/2004	Foley	
2004/0102790	A1	5/2004	Ralph et al.	
2004/0106927	A1	6/2004	Ruffner et al.	
2004/0117019	A1	6/2004	Trieu et al.	
2004/0167535	A1	8/2004	Errico et al.	
2004/0167536	A1	8/2004	Errico et al.	
2004/0172037	A1	9/2004	Dorchak	
2004/0225295	A1	11/2004	Zubok et al.	
2005/0010213	A1	1/2005	Stad et al.	
2005/0027300	A1	2/2005	Hawkins et al.	
2005/0043741	A1	2/2005	Michelson	
2005/0075644	A1	4/2005	DiPoto et al.	
2005/0119665	A1	6/2005	Keller	
2005/0143747	A1	6/2005	Zubok et al.	
2005/0159756	A1	7/2005	Ray	
2005/0165408	A1	7/2005	Puno et al.	

### FOREIGN PATENT DOCUMENTS

DE	29916078	U	11/1999
DE	29916078	U1	11/1999
DE	20012549	U	10/2000
DE	20012549	U1	10/2000
EP	0 880 938	A1	12/1998
EP	0880938		12/1998

(56)

**References Cited**

FOREIGN PATENT DOCUMENTS

EP 1 153 582 A2 11/2001  
WO 0074605 A1 12/2000  
WO WO 00/74605 12/2000

OTHER PUBLICATIONS

[No Author Listed] Metronic Sofamor Danek, "Catalyst Anterior Instrument Set," pp. 1-10 (2004).

Capasso, G. Velotti A. and Auzino, G., "Mechanical Behavior of Two Types of Vertebral Distractors Submitted to Compression-Flexion Tests," Ital J. Orthop Traumatol. 13(1):121-6 (1987).

Demetropoulos, C.K., Truumees, E., Herkowitz, H.N. and Yang, K.H., "Development and calibration of a load sensing cervical distractor capable of withstanding autoclave sterilization," Med Eng Phys. 27(4):343-6 (2005).

Rutsky, V.V. and Valkav, A.N., "Designing a dynamic spinal distractor," Med Tekh. 4:29-32 (1995).

[No Author Listed] Depuy Motech., "Keystone Graft Instruments Anterior Cervical Technique," Technical Manual. 1998, 16 pages.

[No Author Listed] FRA Space Instruments. For anterior lumbar fusion (ALIF) using straight anterior or anterolateral approach. Synthes Spine, 1998, 15 pages.

\* cited by examiner

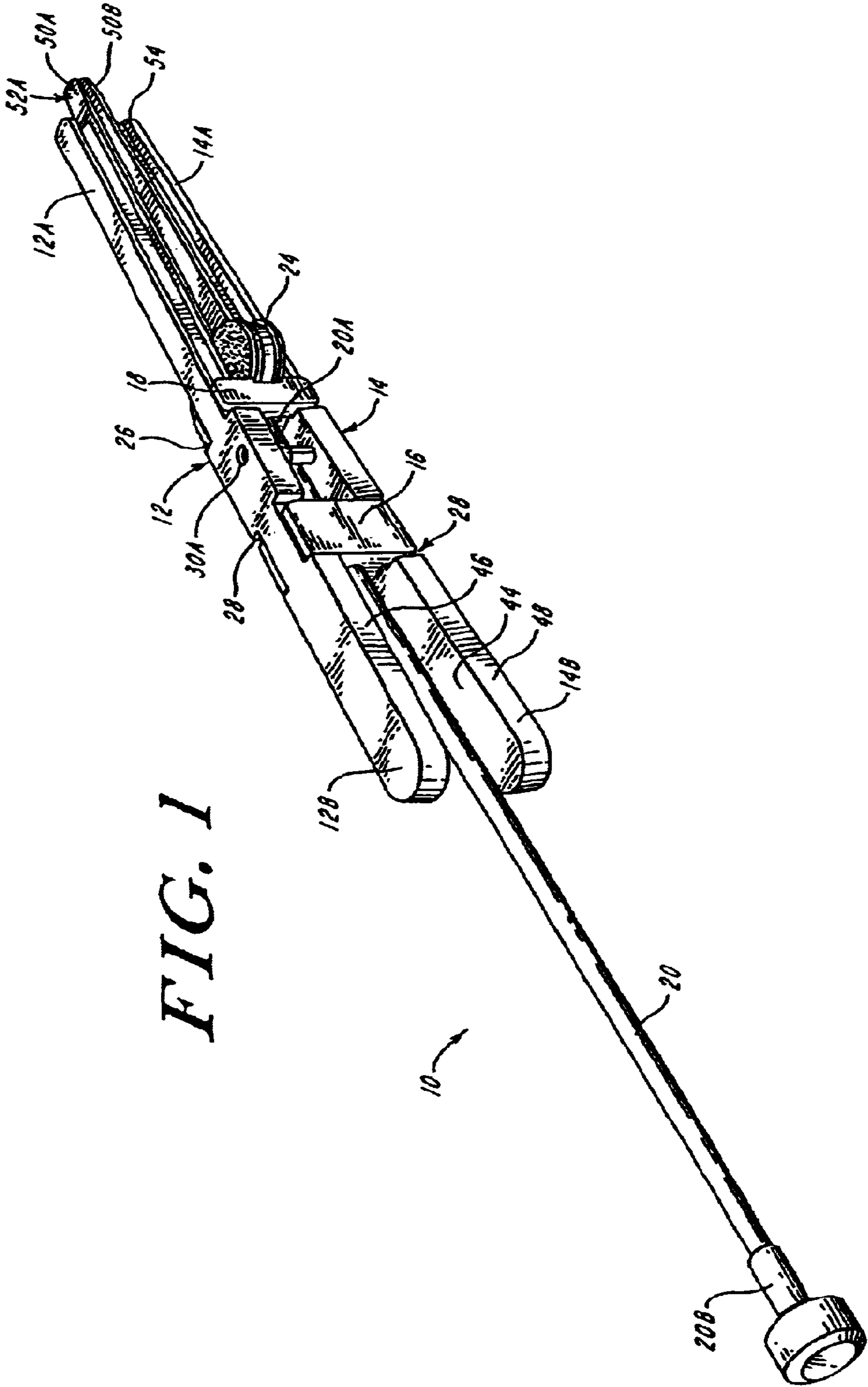


FIG. 1



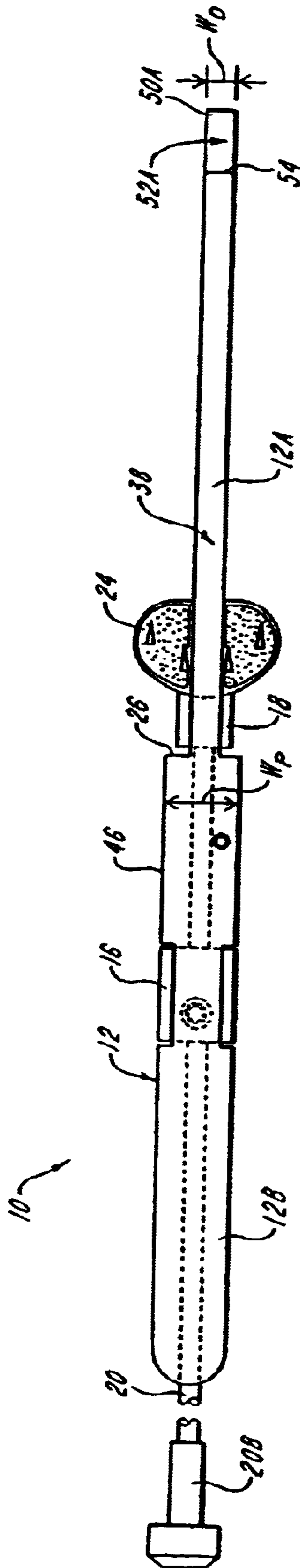
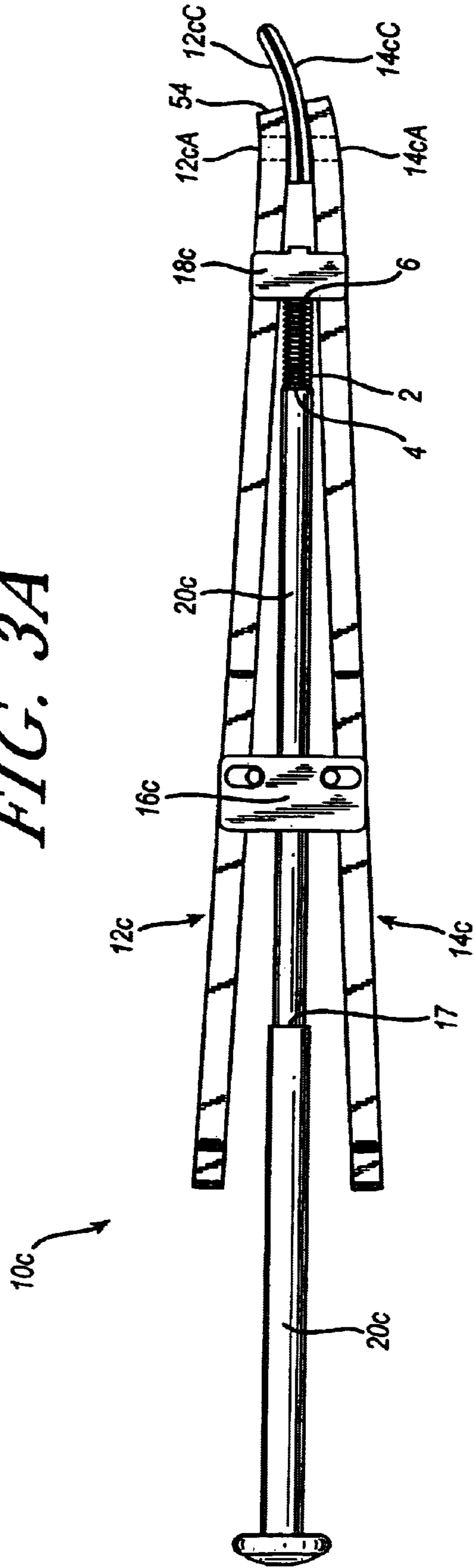


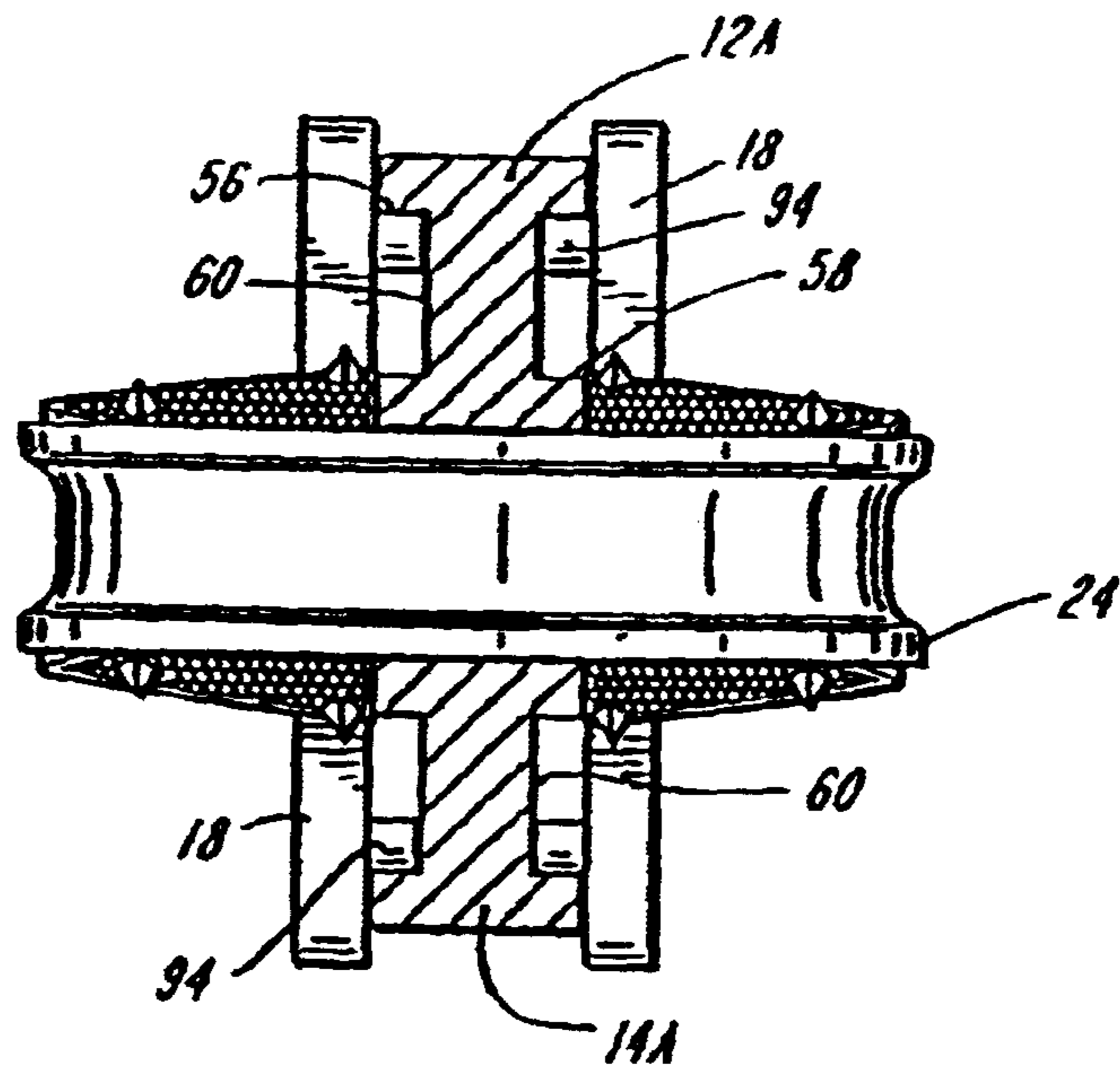
FIG. 3

FIG. 3A

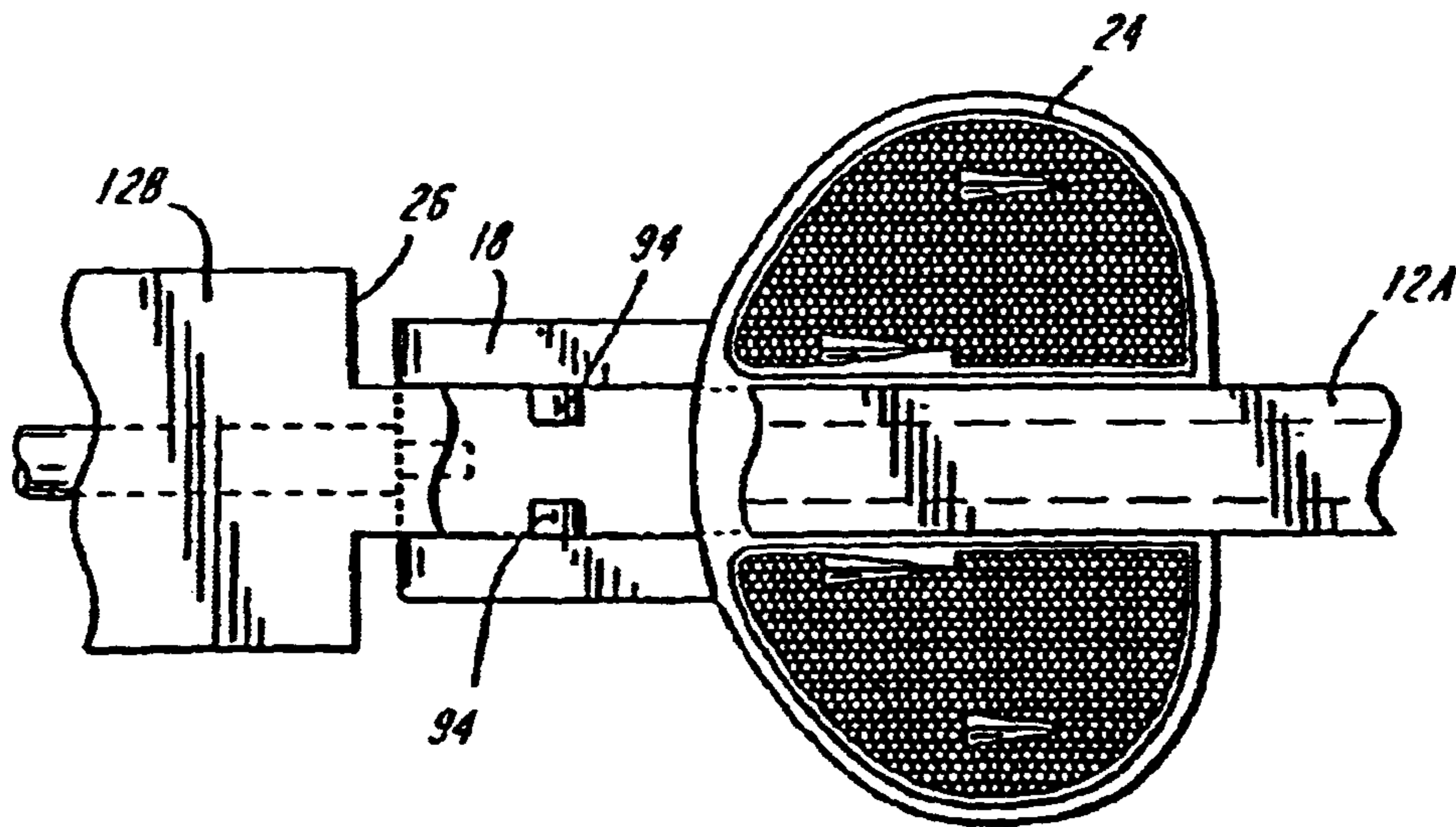




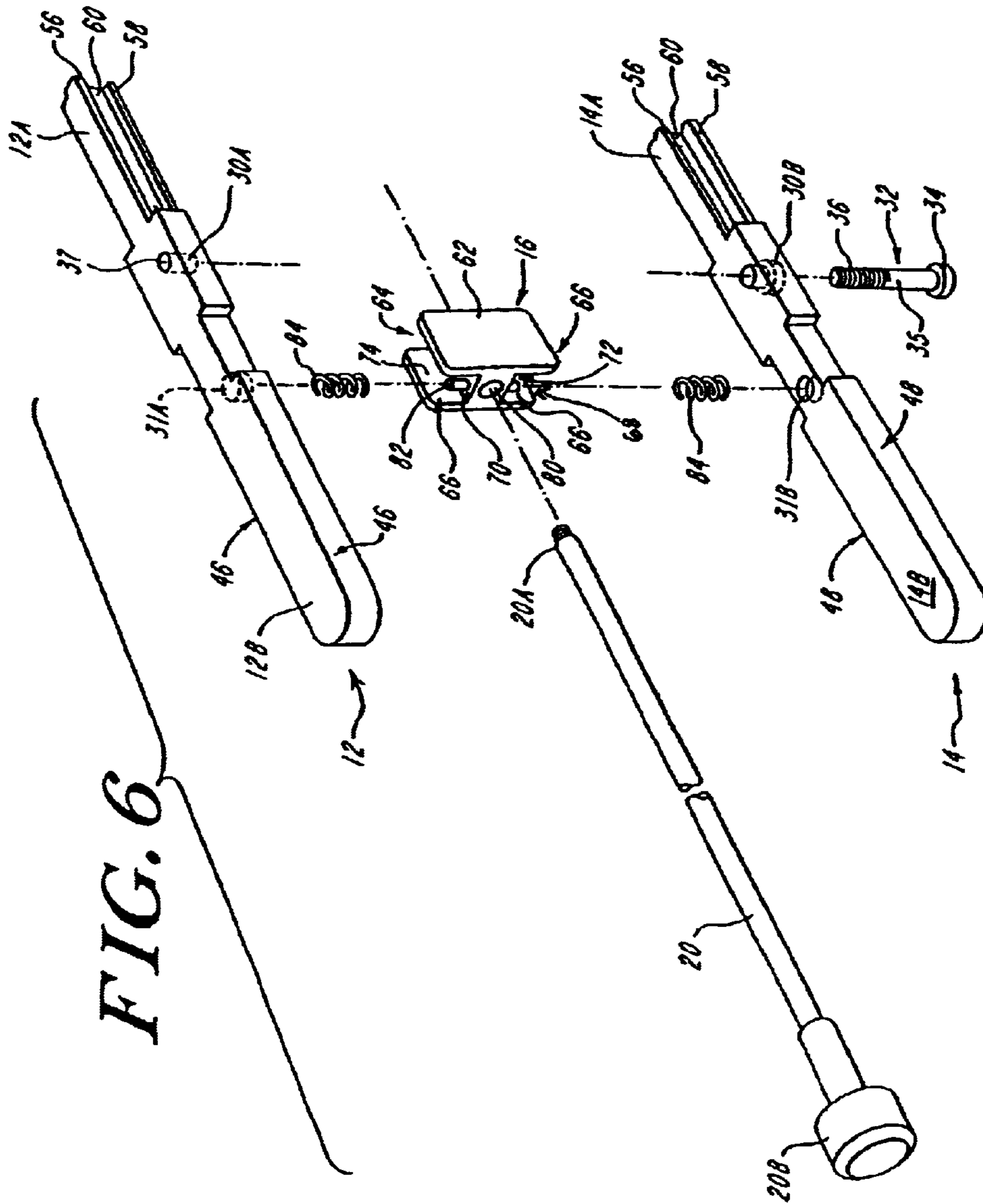




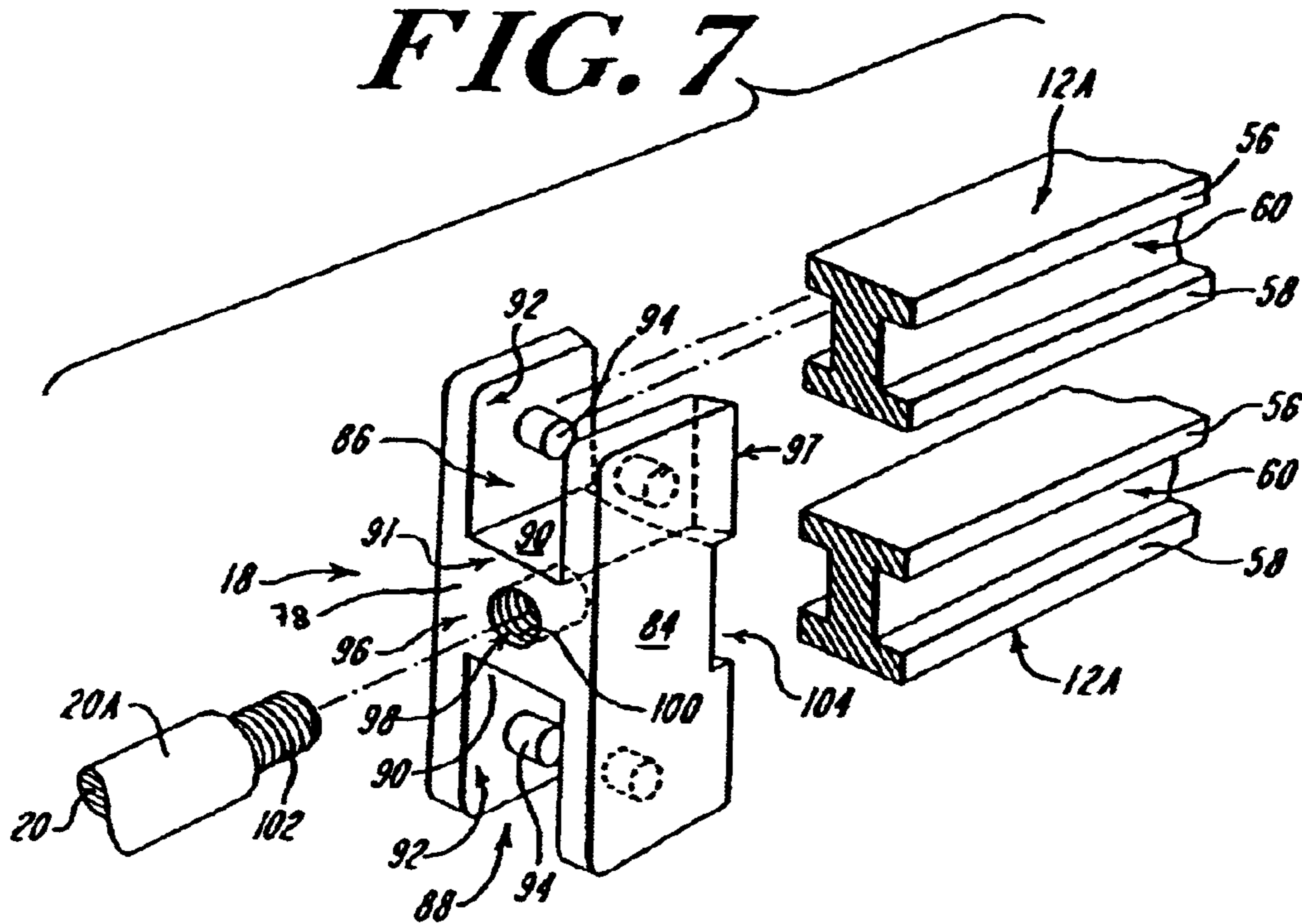
**FIG. 4**



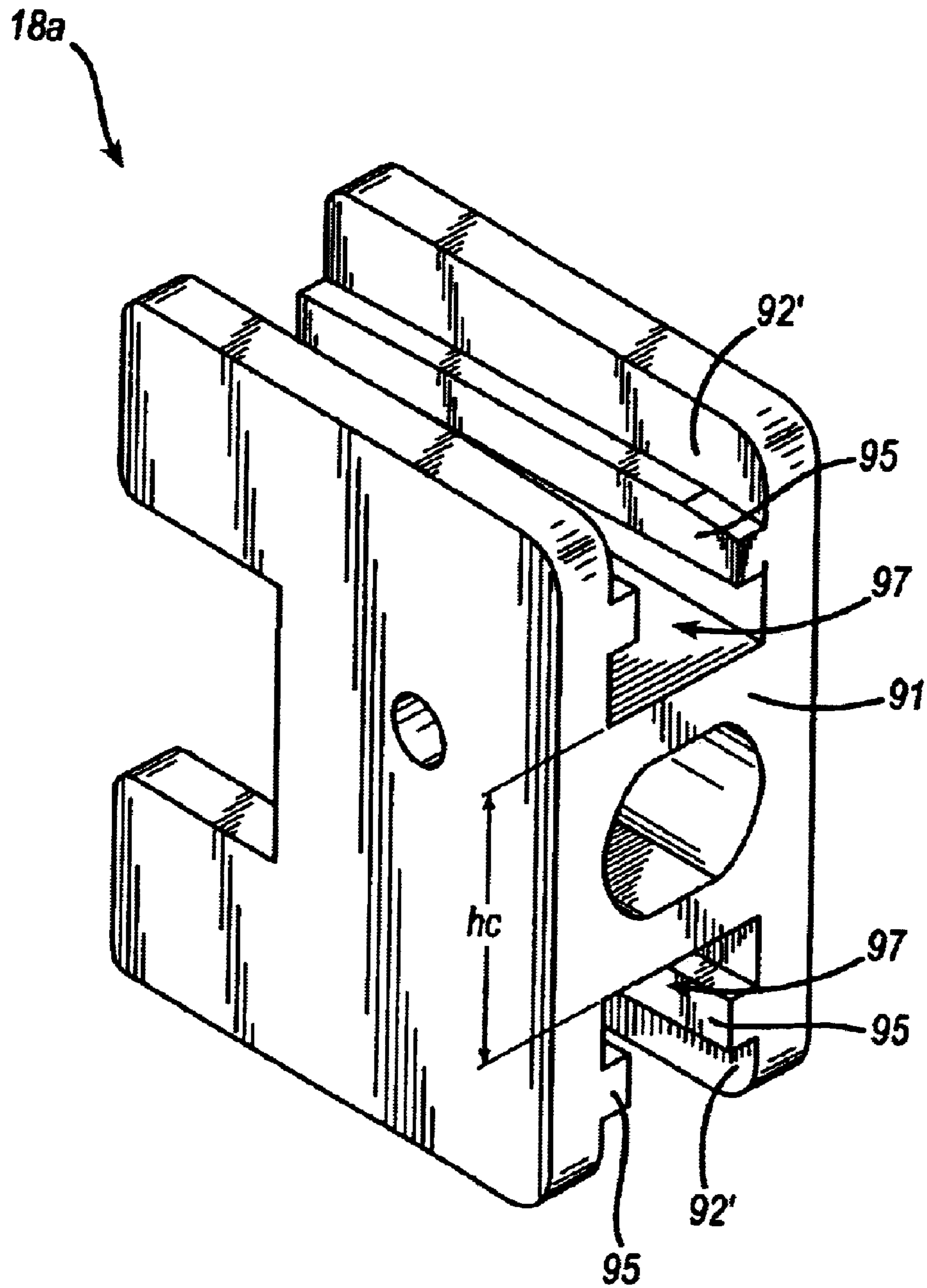
**FIG. 5**

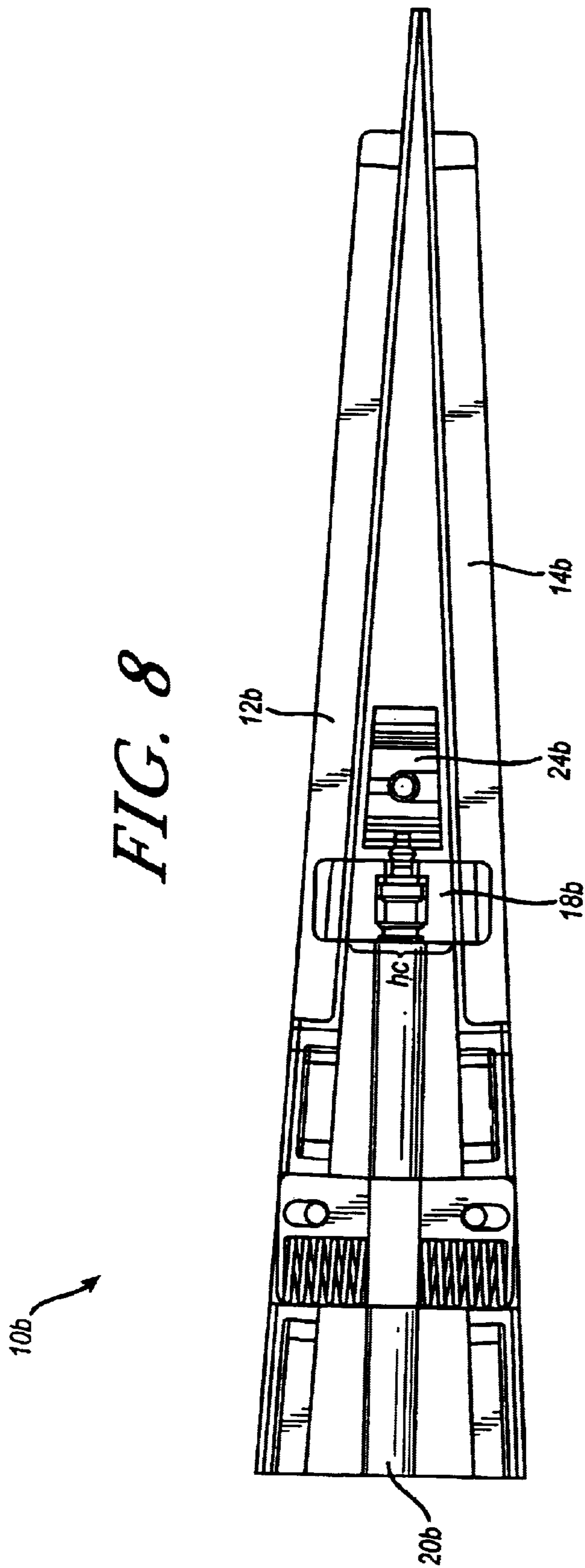


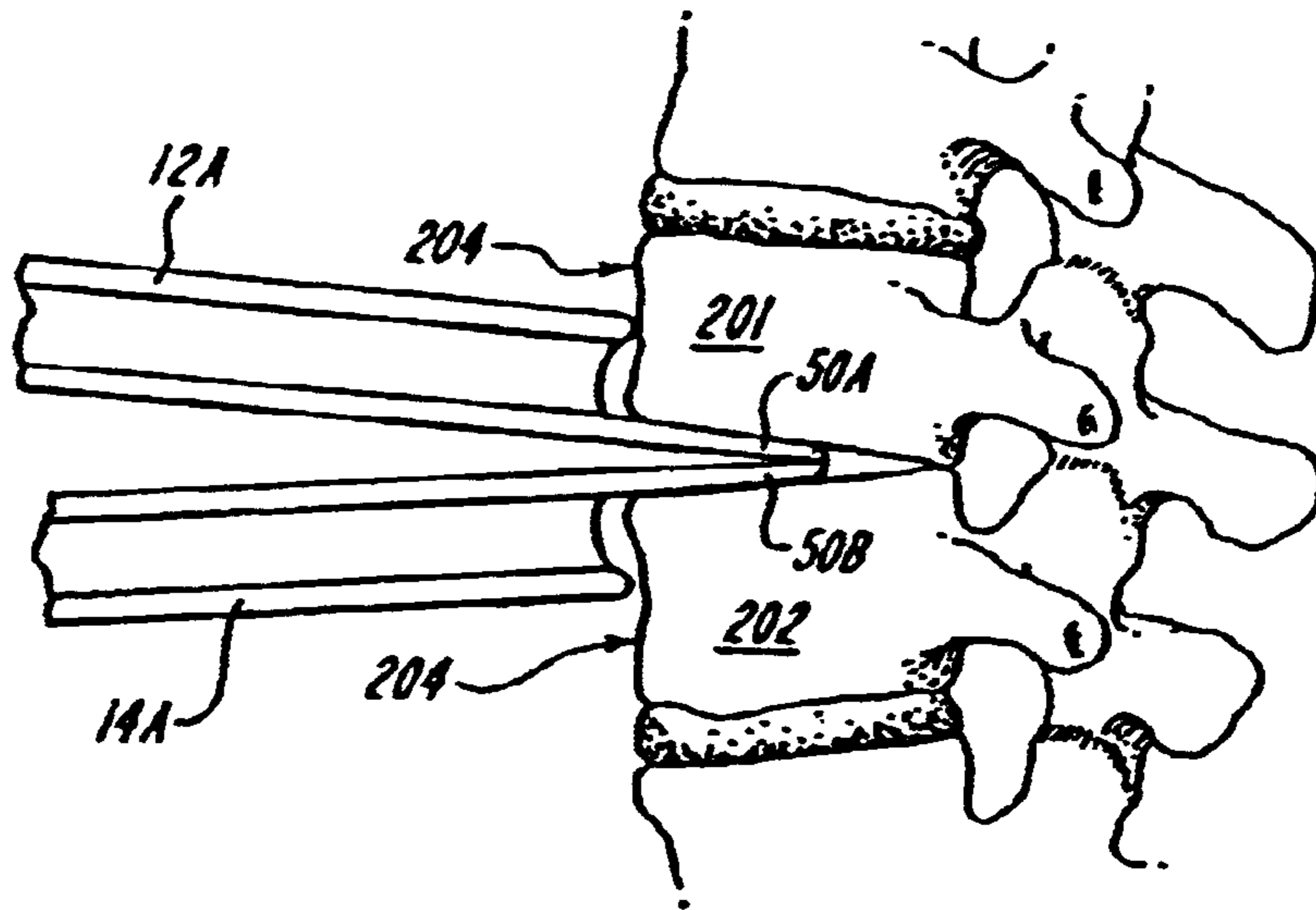
**FIG. 7**



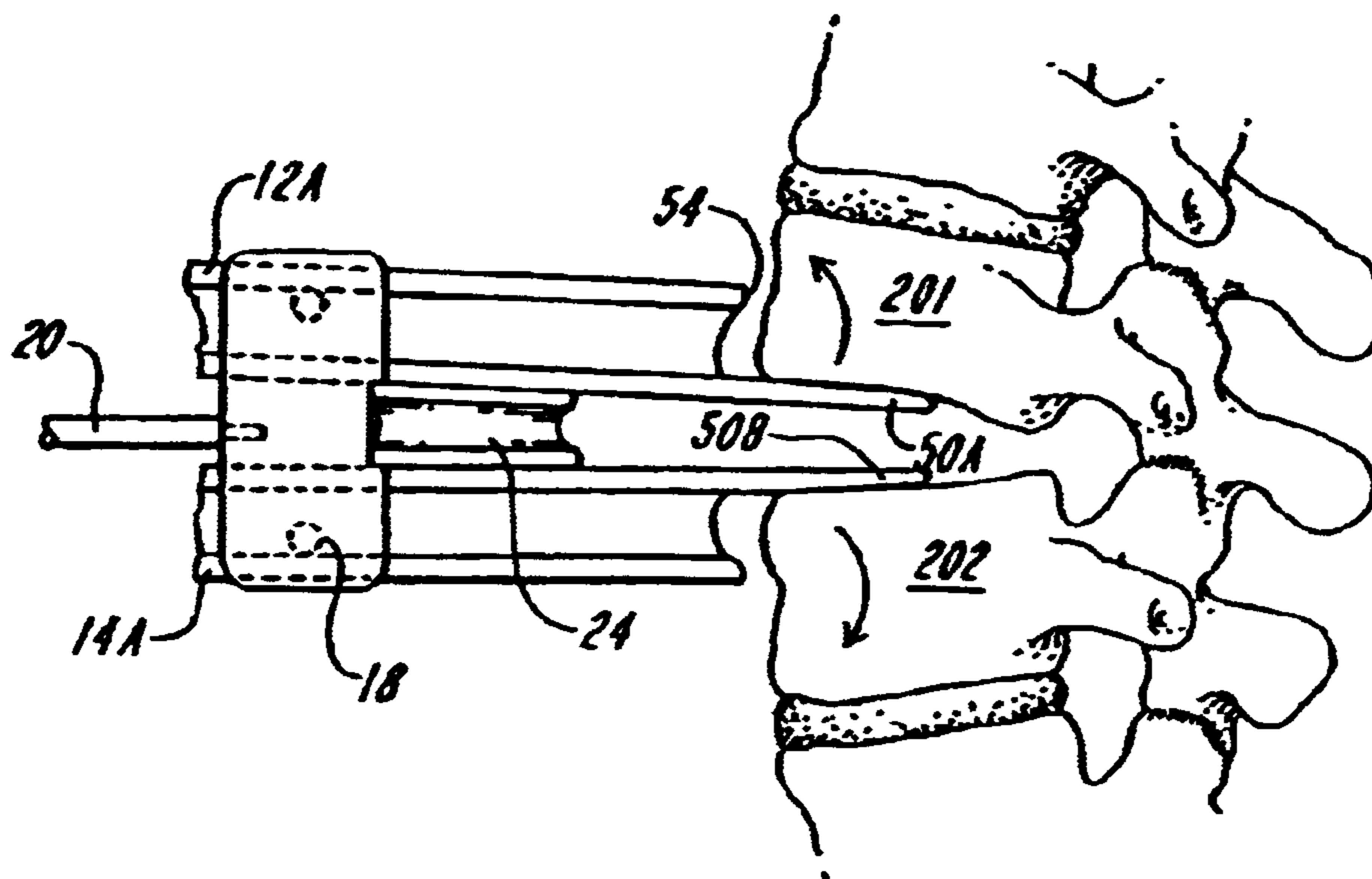
*FIG. 7A*



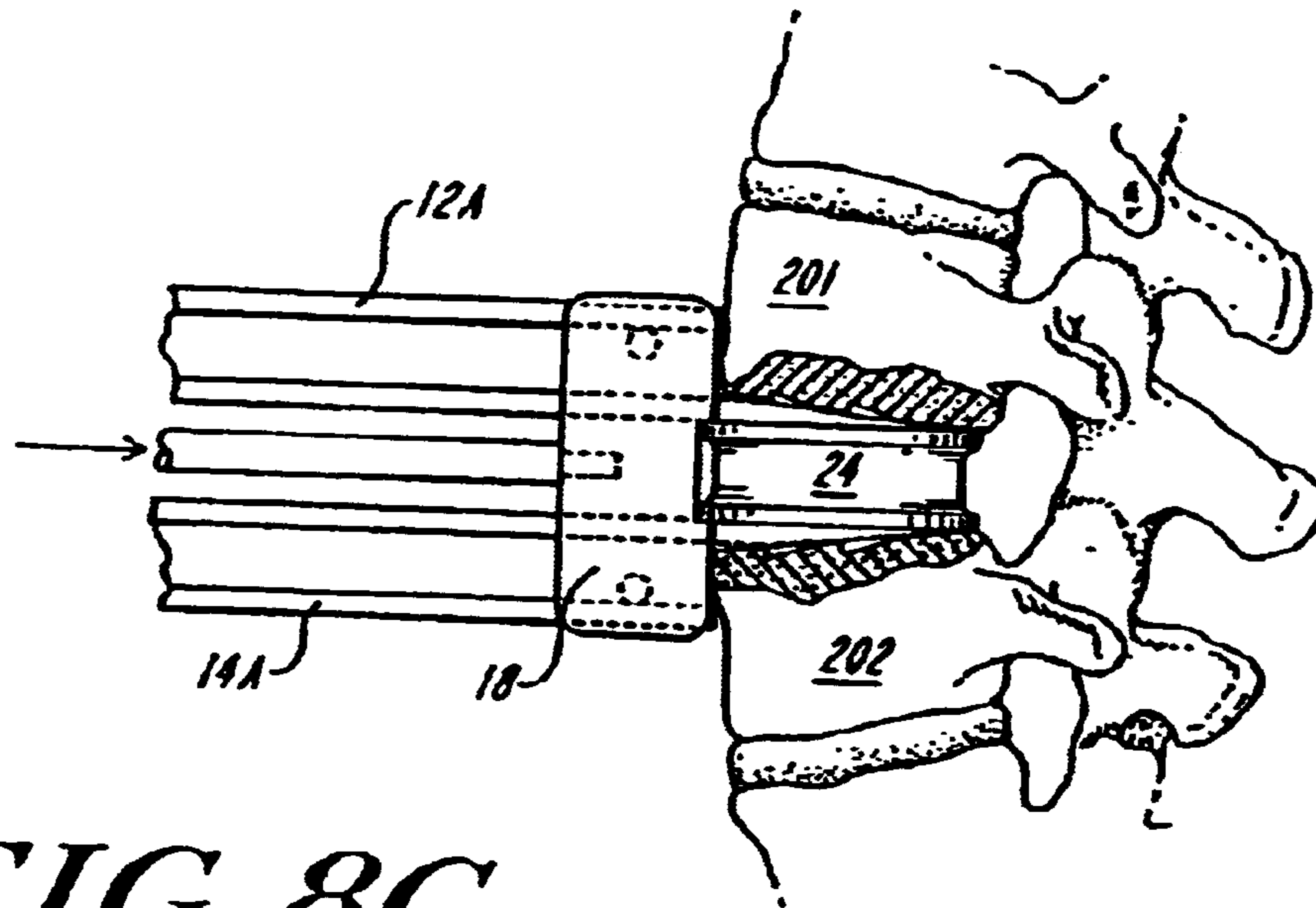




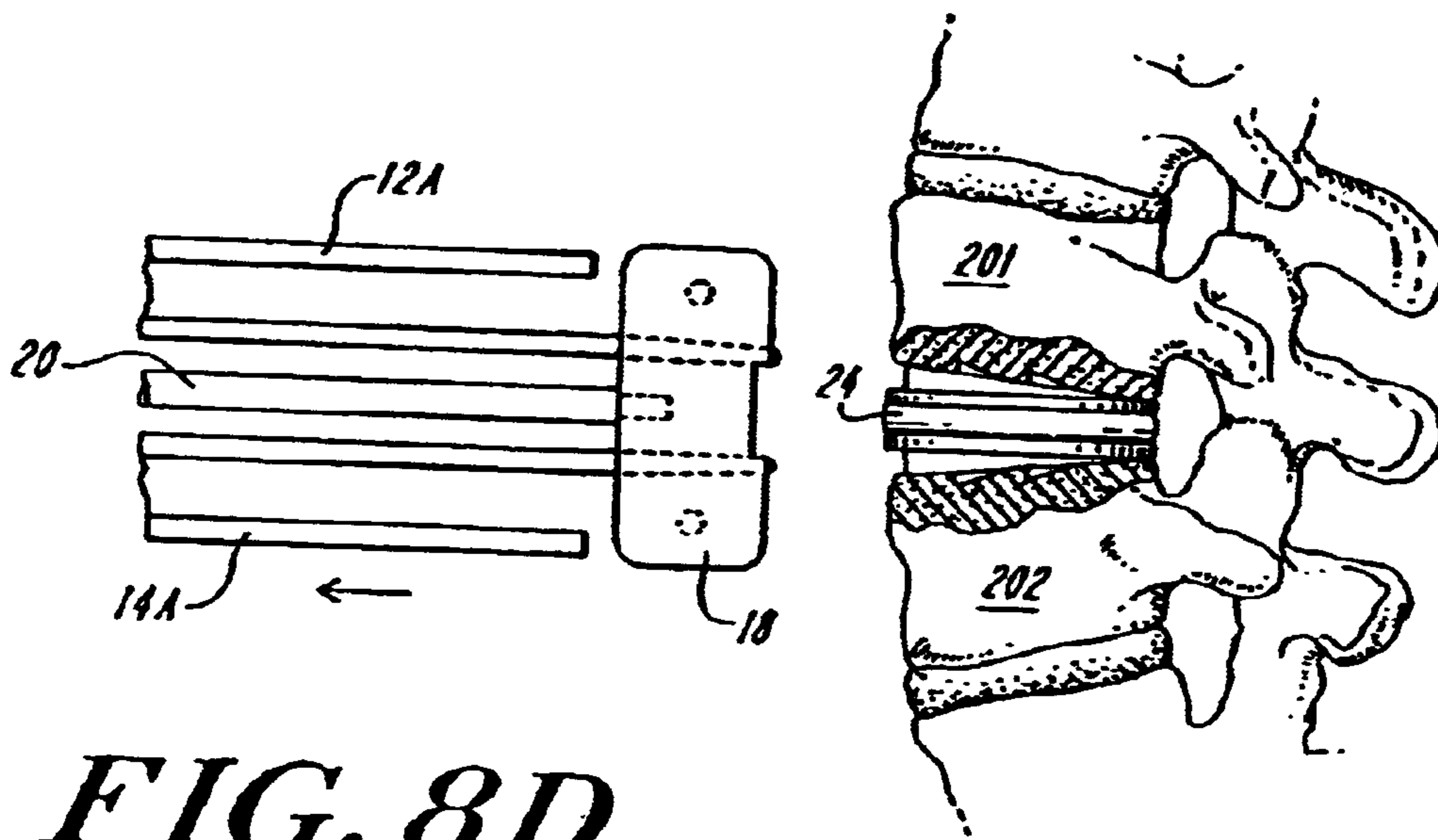
**FIG. 8A**



**FIG. 8B**



**FIG. 8C**



**FIG. 8D**

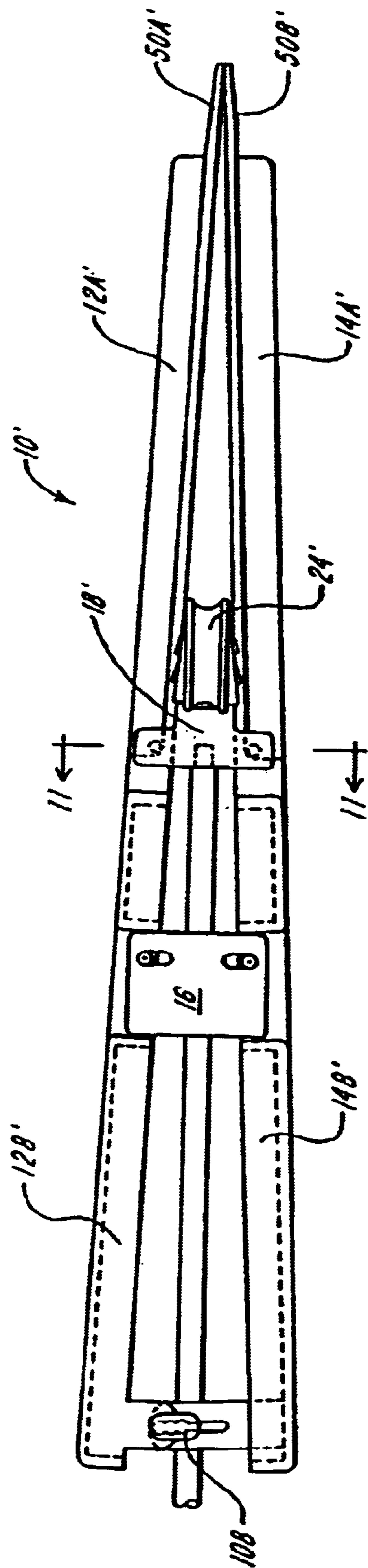


FIG. 9



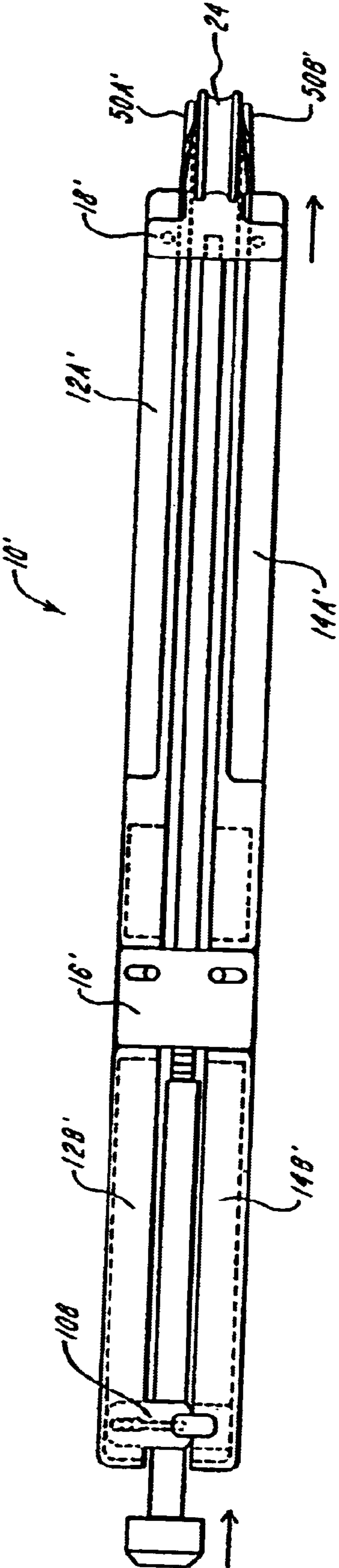
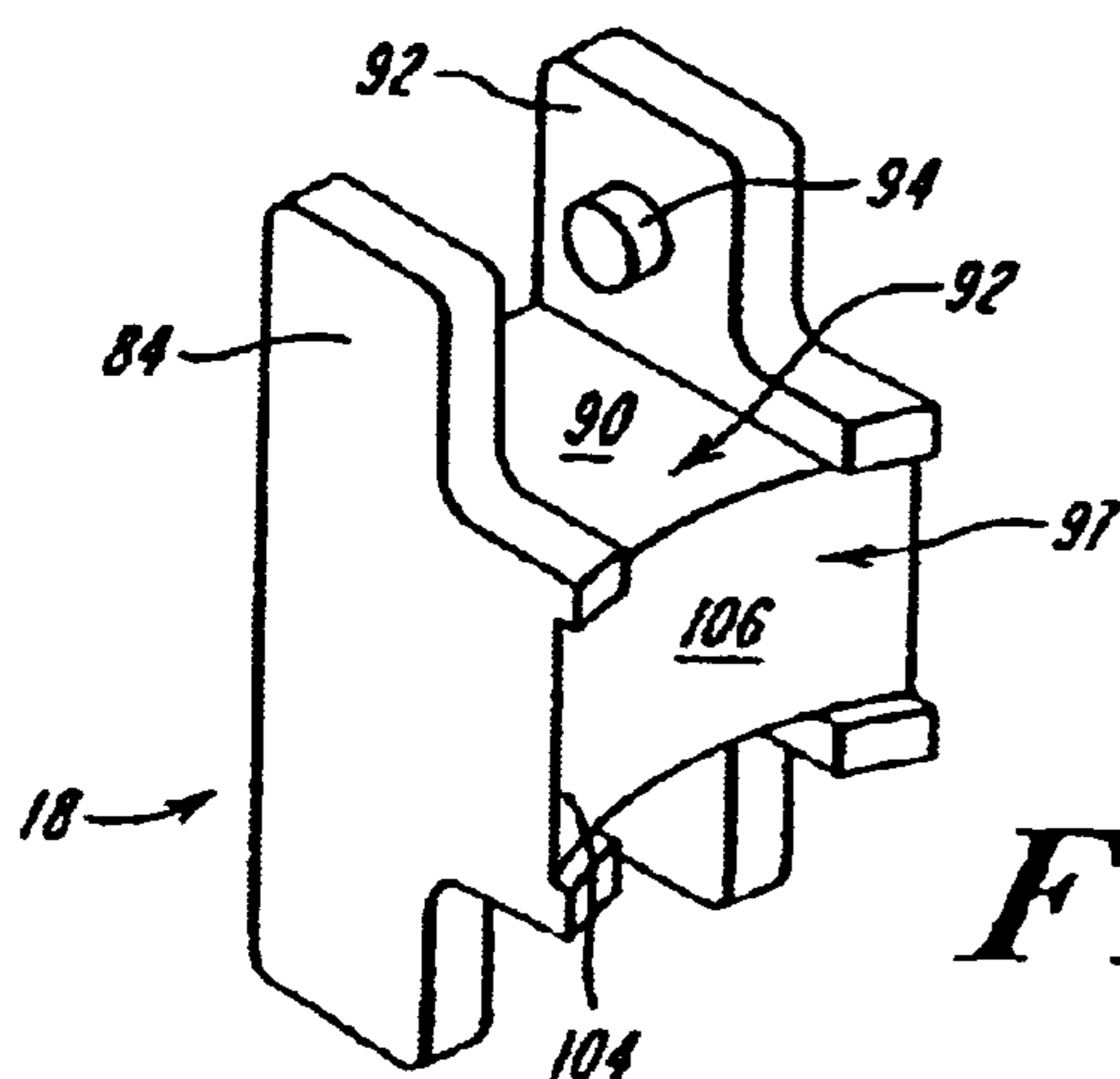
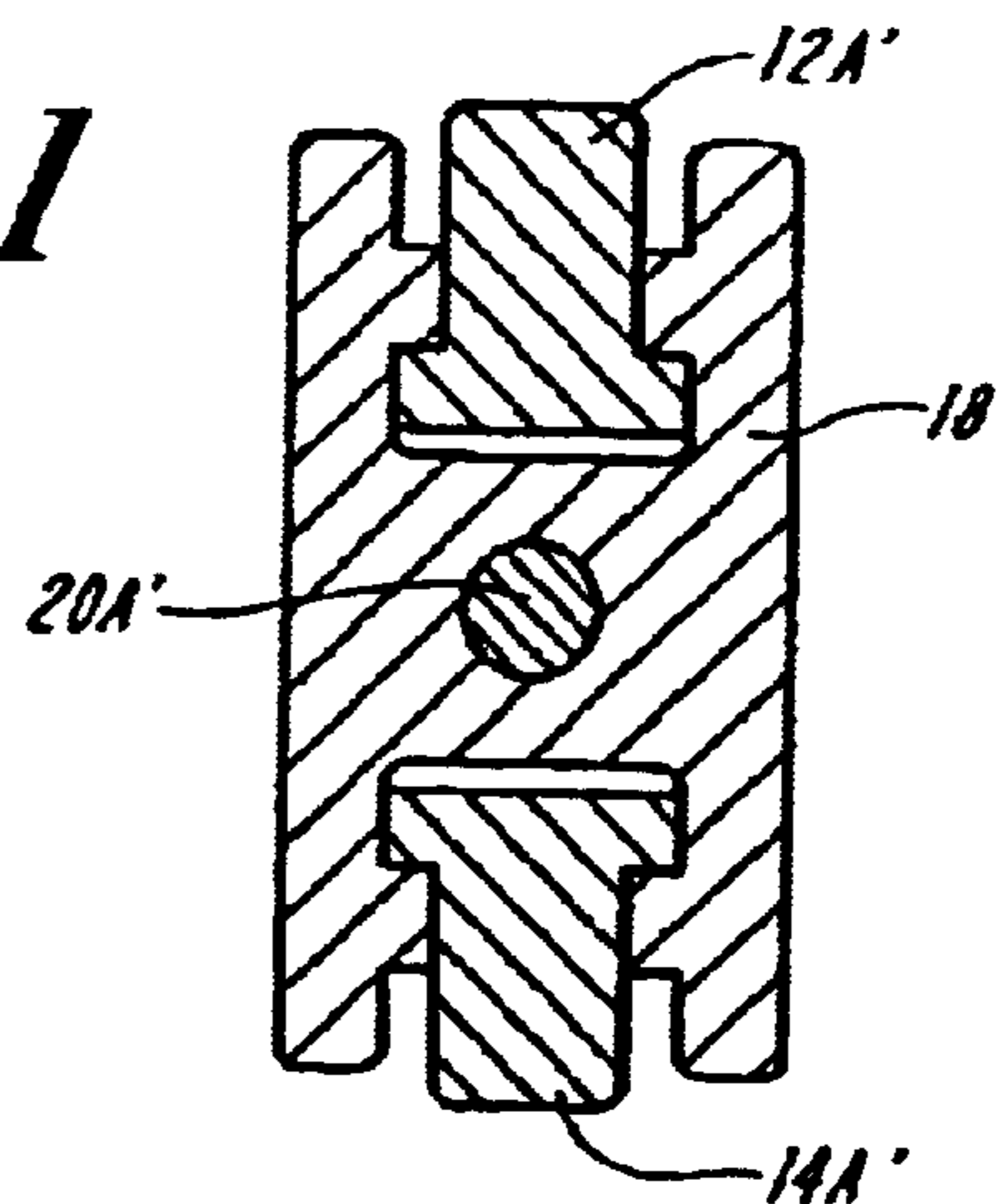
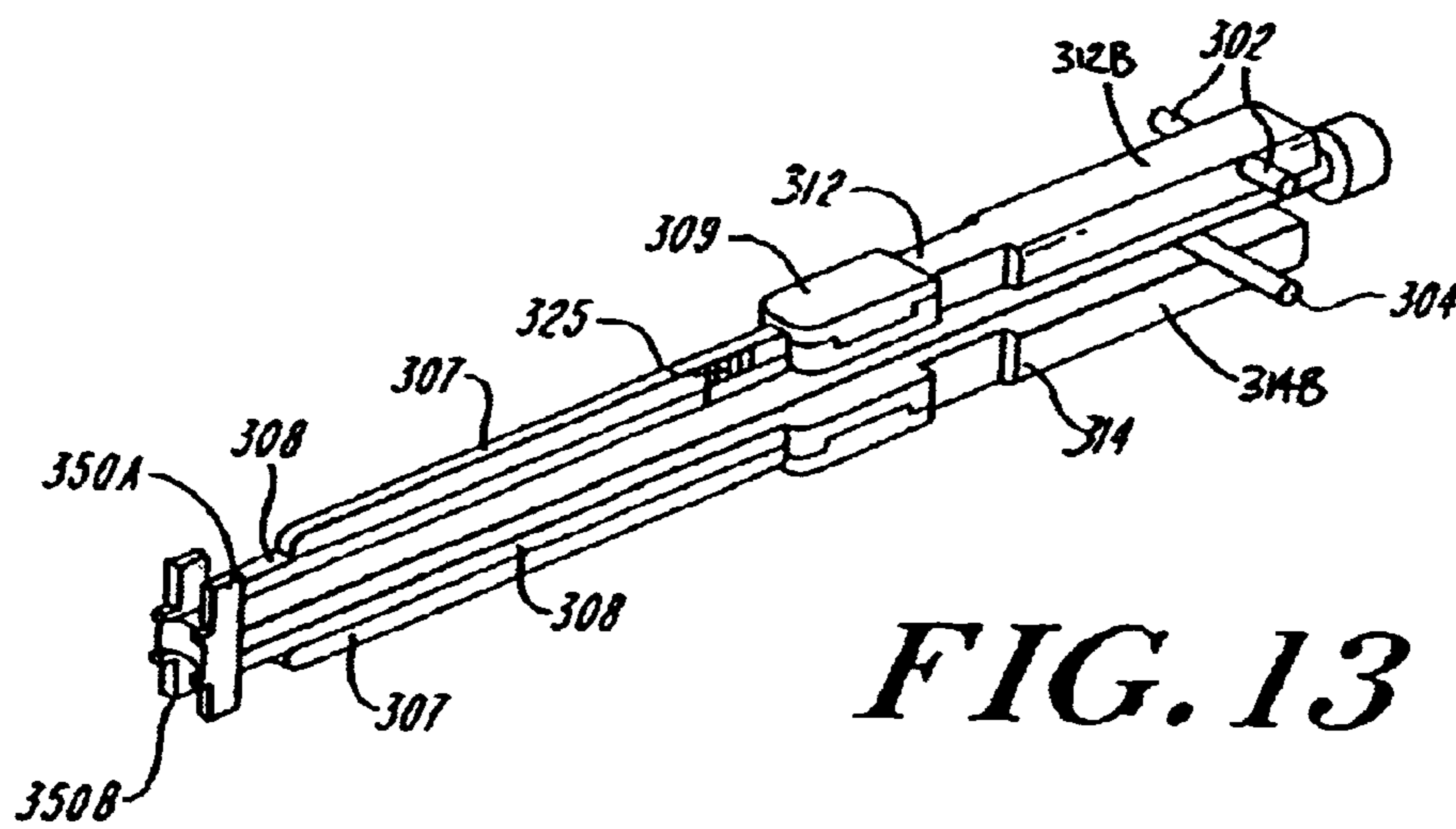


FIG. 10

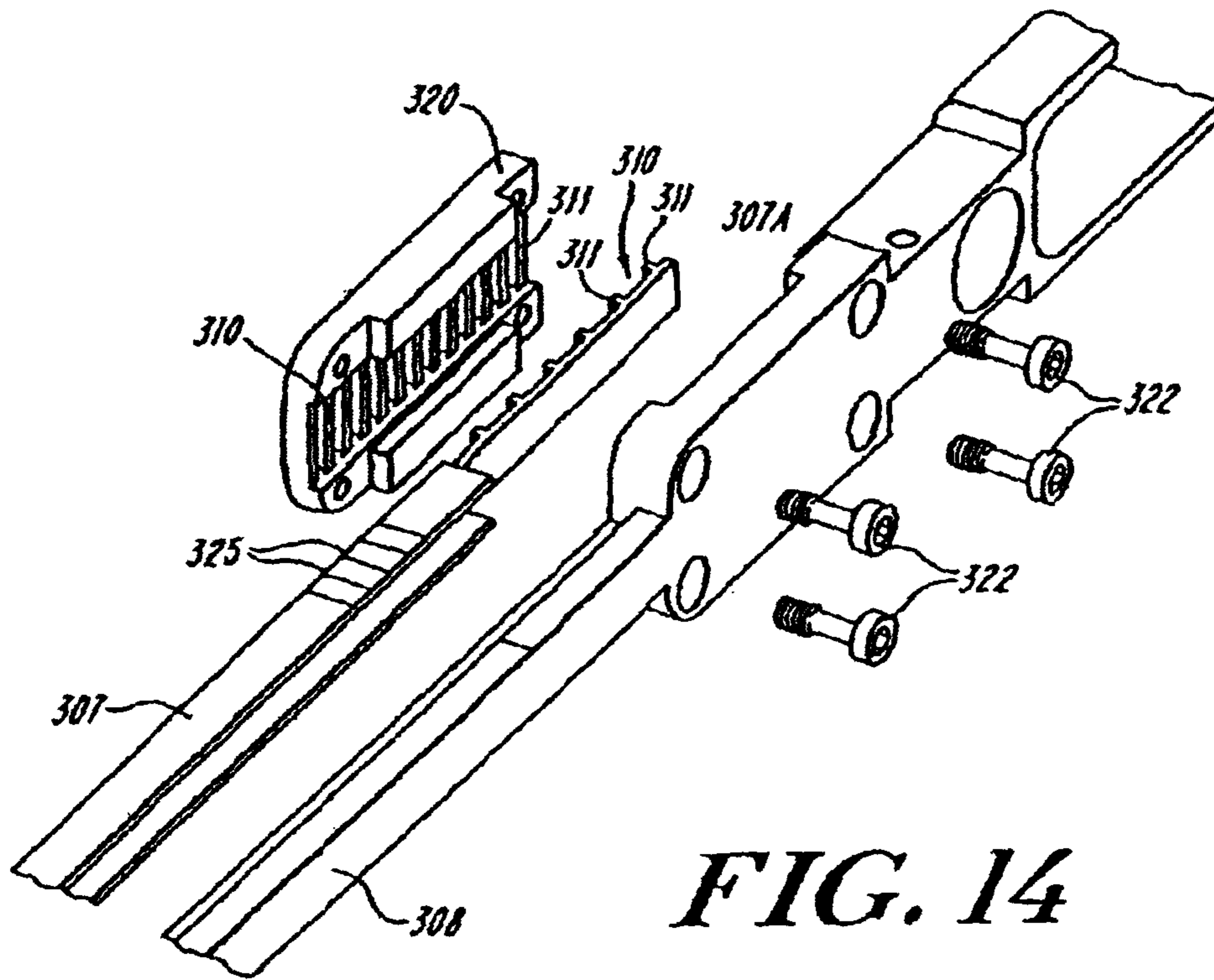
**FIG. 11**



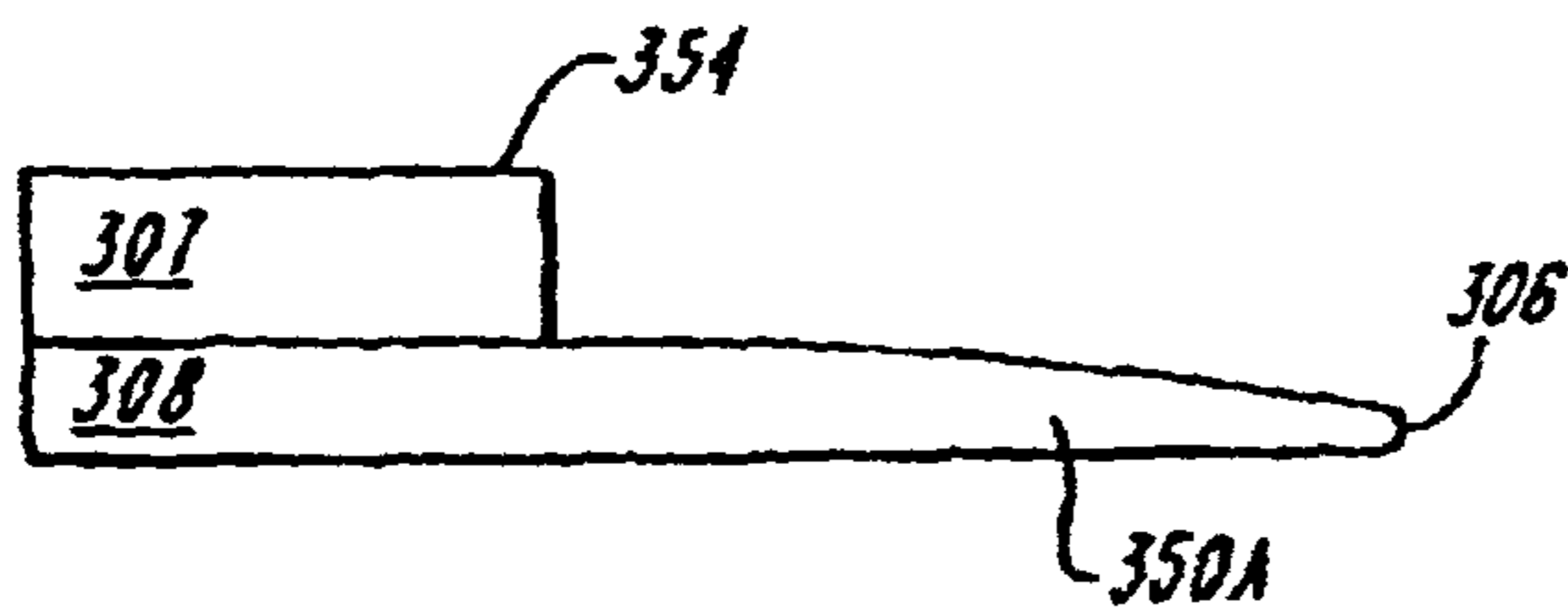
**FIG. 12**



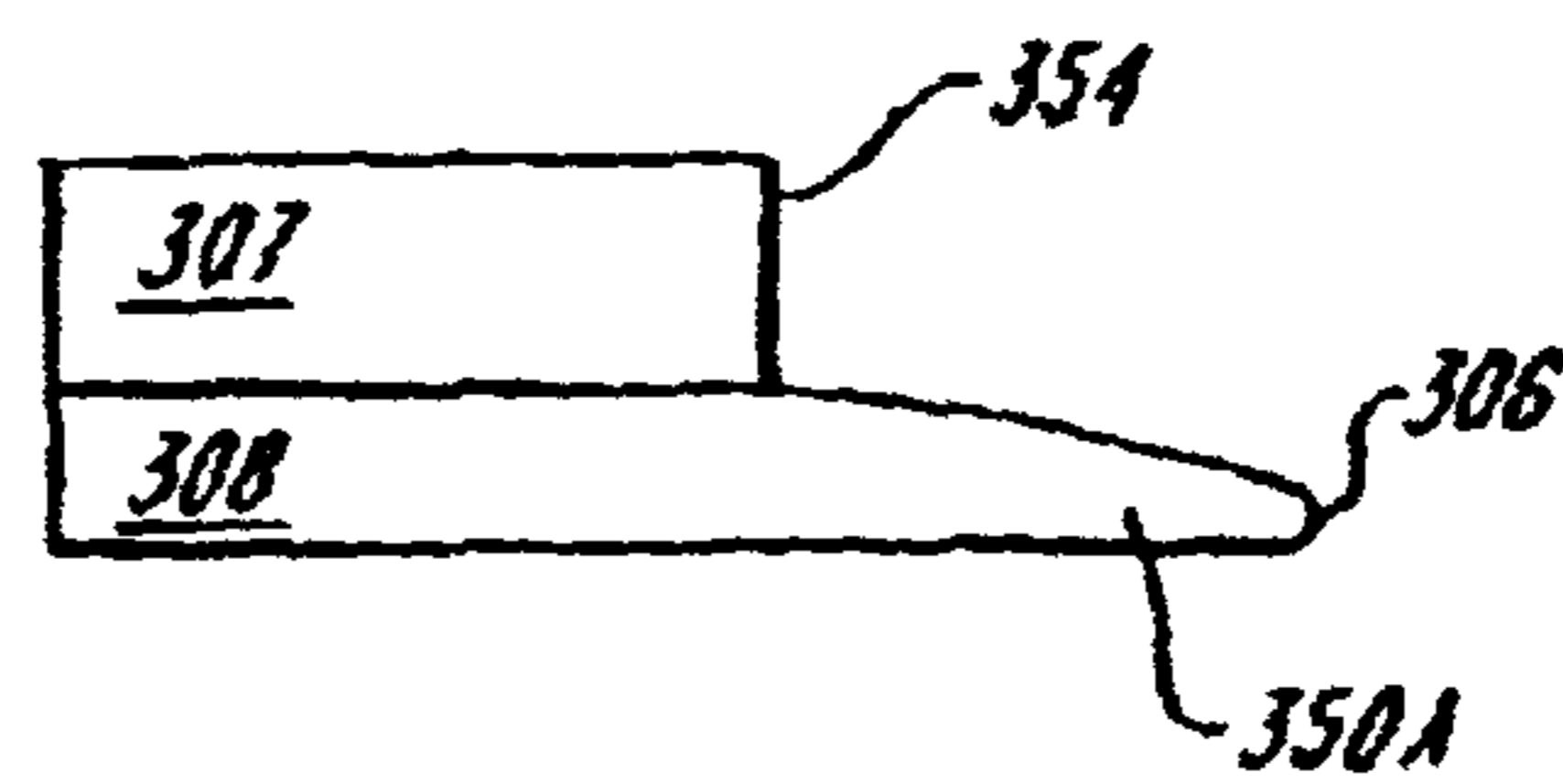
**FIG. 13**



**FIG. 14**

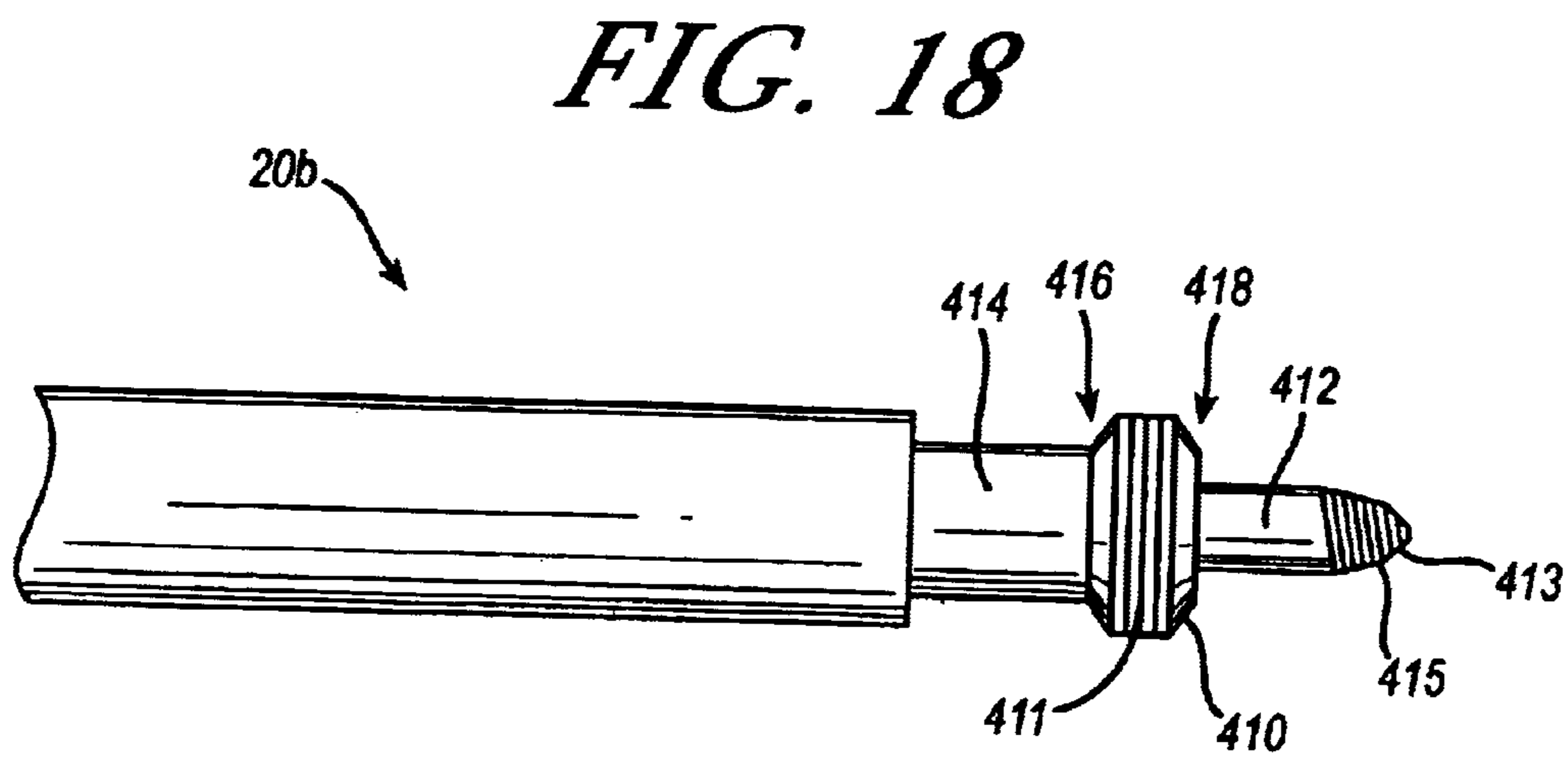
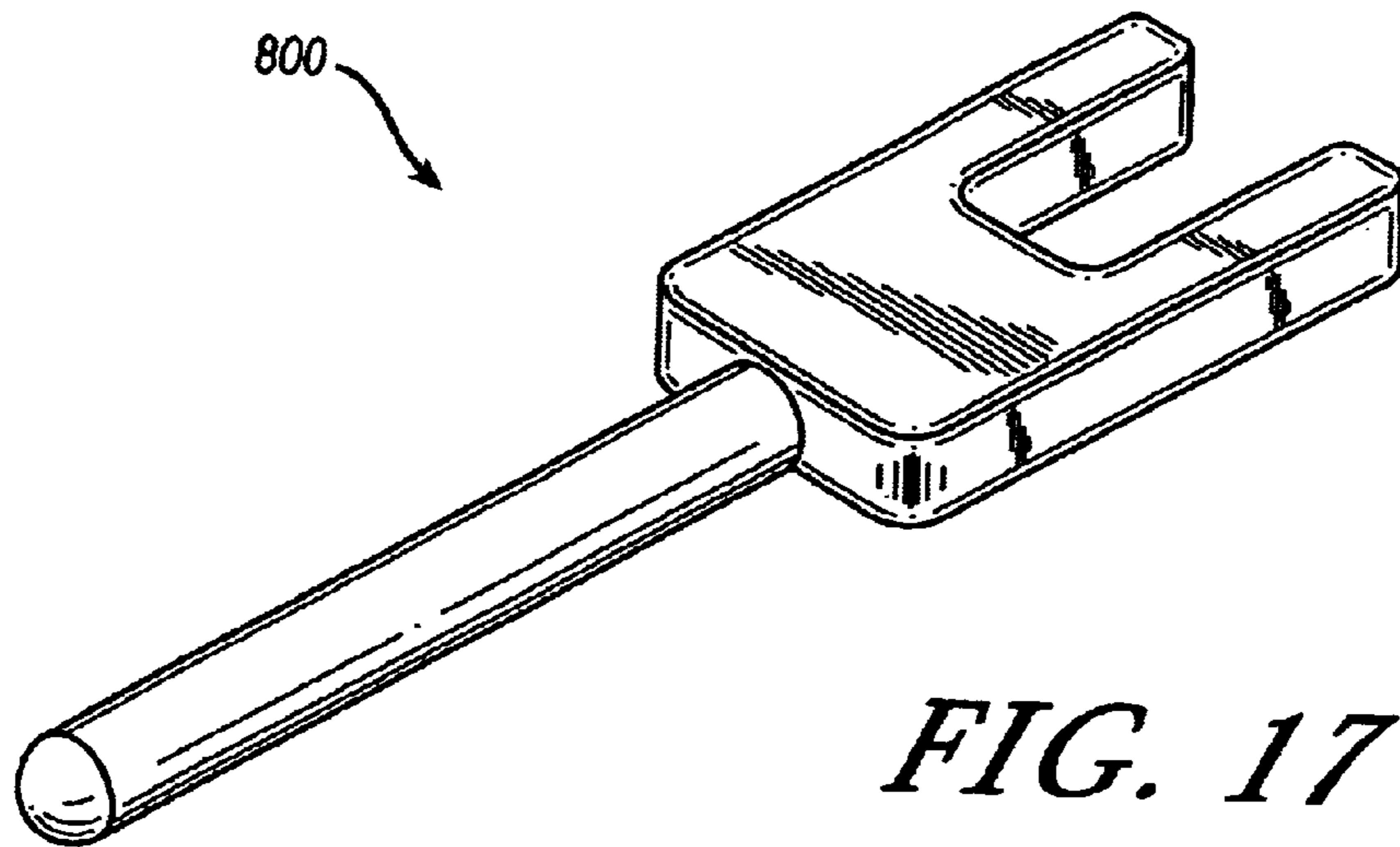


**FIG. 15A**

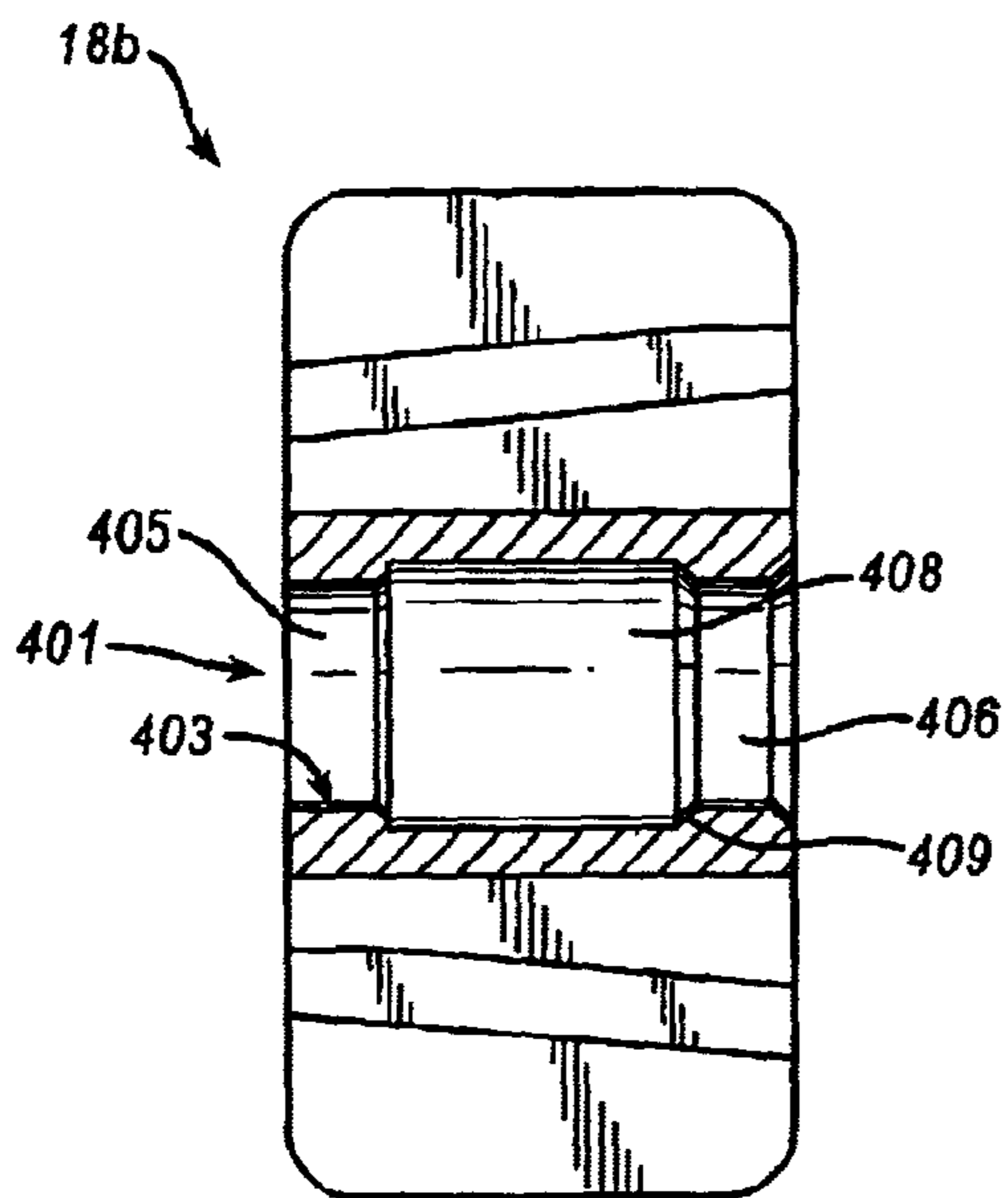


**FIG. 15B**

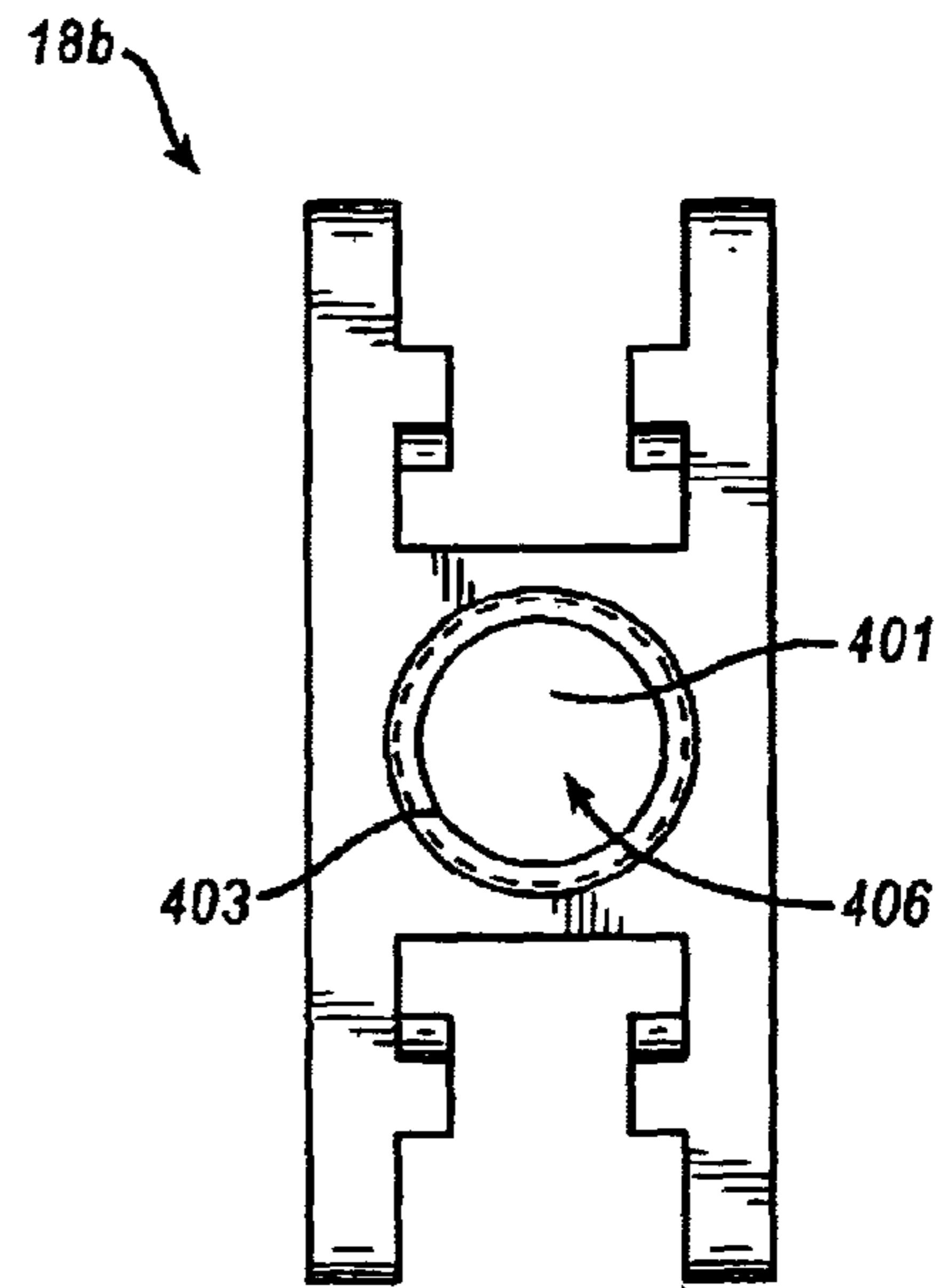




*FIG. 19A*



*FIG. 19B*



## MEDICAL INSTALLATION TOOL

**Matter enclosed in heavy brackets [ ] appears in the original patent but forms no part of this reissue specification; matter printed in italics indicates the additions made by reissue; a claim printed with strikethrough indicates that the claim was canceled, disclaimed, or held invalid by a prior post-patent action or proceeding.**

## CROSS-REFERENCE TO RELATED APPLICATIONS

**[This application]** *More than one reissue application has been filed for the reissue of U.S. Pat. No. 6,755,841. This application is a continuation reissue of U.S. patent application Ser. No. 13/331,675, filed on Dec. 20, 2011, now U.S. Pat. No. Re. 44,835, which is a continuation reissue of U.S. patent application Ser. No. 11/397,887, filed on Mar. 29, 2006, now U.S. Pat. No. Re. 43,317, which is a reissue of U.S. patent application Ser. No. 10/011,264, filed on Dec. 7, 2001, now U.S. Pat. No. 6,755,841, which is a continuation-in-part of U.S. patent application Ser. No. 09/566,514, filed on May 8, 2000, now U.S. Pat. No. 6,478,800 entitled "Medical Installation Tool," the entire contents of each of which is hereby expressly incorporated herein by reference.*

## BACKGROUND OF THE INVENTION

The invention relates to a tool for inserting prostheses within the body, and more particularly to tools for inserting prostheses, such as artificial discs and cages, within an intervertebral space.

Spinal surgery involves many challenges as the long-term health and mobility of the patient often depends on the surgeon's technique and precision. One type of spinal surgery involves the removal of the natural disc tissue that is located between adjacent vertebral bodies. Procedures are known in which the natural, damaged disc tissue is replaced with an interbody cage or fusion device, or with a disc prosthesis.

The insertion of an article, such as an artificial disc prosthesis, presents the surgeon with several challenges. The adjacent vertebral bodies collapse upon each other once the natural disc tissue is removed. These bodies must be separated to an extent sufficient to enable the placement of the prosthesis. However, if the vertebral bodies are separated, or distracted, to beyond a certain degree, further injury can occur. The disc prosthesis must also be properly positioned between the adjacent vertebral bodies. Over-insertion, or under-insertion of the prosthesis can lead to pain, postural problems and/or limited mobility or freedom of movement.

Specialized tools have been developed to facilitate the placement of devices, such as disc prosthesis, between adjacent vertebral bodies of a patient's spine. Among the known tools for performing such procedures are separate spinal distractors and insertion devices. The use of separate tools to distract the vertebral bodies and insert a disc prosthesis or graft can prove cumbersome. Further, the use of some distractors can cause over-distracting of the vertebral bodies.

Exemplary devices for installing prosthesis and/or grafts between vertebral bodies are disclosed in U.S. Pat. Nos. 5,431,658 and 5,505,732. U.S. Pat. No. 5,431,658 discloses a facilitator device for the insertion of bone grafts between two adjacent vertebrae. The disclosed tool has two flat, tong-like guides that distract the vertebrae as a screw-type inserter forces the graft between the distracted vertebrae. U.S. Pat. No. 5,505,732 discloses an apparatus and a method of insert-

ing spinal implants. The intervertebral space is first distracted and a hollow sleeve having teeth at one end is then driven into the vertebrae that are adjacent the disc space. A drill is then passed through the hollow sleeve, removing the disc and the bone in preparation for receiving the spinal implant, which is then inserted through the sleeve.

Despite existing tools and technologies, there remains a need to provide a device to facilitate the proper and convenient insertion of an object, such as a disc prosthesis, between adjacent vertebral bodies while minimizing the risk of further injury to the patient.

## SUMMARY OF THE INVENTION

The present invention provides a device useful for implanting prostheses, such as artificial spinal discs and cages, within a patient in a safe and efficient manner. The installation tool of the invention generally includes a pair of opposed levers, each of which has a proximal handle portion and a distal portion. A fulcrum is disposed between the two levers to enable proper operation of the tool. The tool further includes a pusher block that is positioned between the two levers and is selectively movable between an initial location distal of the fulcrum and a final location adjacent the distal end of the levers. The pusher block includes a proximal end, a distal end, and a bore extending at least partially therethrough. A pusher rod, which facilitates movement of a pusher block, has a distal end extending into the bore in the pusher block and a proximal, handle end.

The pusher rod and/or pusher block can be adapted to mate to a variety of prosthesis devices. In one embodiment, the pusher block can include a blind bore and a distal end of the pusher rod can mate with the blind bore in the pusher block. The pusher block can thus include a distally facing surface having surface features adapted to conform to or mate with complementary surface features on a prosthesis. In another embodiment, the bore can extend entirely through the pusher block to allow a distal end of the pusher rod to extend through the bore in the pusher block. The pusher rod can thus include a distal tip that is effective to mate to a prosthesis.

In yet another embodiment, the rod can include a first externally threaded distal portion and a second externally threaded distal portion. The second distal portion is positioned proximal to the first distal portion, and has a diameter greater than a diameter of the first distal portion. The bore of the pusher block can include a threaded proximal opening, a distal opening, and a chamber formed therebetween. The proximal opening is threadingly matable with the second distal portion of the rod to allow the second distal portion of the rod to be threadingly inserted through the proximal opening and positioned within the chamber. The diameter of the distal opening of the pusher block should be less than the diameter of the proximal opening of the pusher block to prevent the second threaded portion of the rod from extending through the distal opening in the pusher block. The threaded second distal portion is preferably freely rotatable within the chamber of the pusher block. The threaded first distal portion of the rod extends through the distal opening in the pusher block and includes a distal tip which is adapted to mate to a prosthesis.

In other aspects of the invention the bore extends entirely through the pusher block and a distal tip of the pusher rod is adapted to extend through the bore in the pusher block. The distal tip of the pusher rod is further adapted to mate to a grasping element effective to releasably engage a prosthesis. The grasping element can include an elongate proximal portion with a bore formed therein and a distal portion that is

effective to releasably engage a prosthesis. The proximal portion has an outer diameter that is adapted to fit within the bore of the distal end of the pusher block. The distal portion of the grasping can include opposed first and second components that are movable between a first, open position, and a second, closed position that is effective to engage a prosthesis. In use, the distal end of the rod threadingly engages the bore of the grasping element. Rotation of the rod in a first direction is effective to cause the elongate proximal portion of the grasping element to move proximally within the bore of the pusher block, thereby moving the first and second components to the second, closed position. Rotation of the rod in a second, opposed direction is effective to cause the elongate proximal portion of the grasping element to move distally out of the bore of the pusher block and move the first and second components to the first, open position. The first and second components can optionally include at least one surface feature effective to engage a prosthesis.

In yet another embodiment, a medical device installation kit can be provided having a pair of opposed levers, a fulcrum disposed between the levers for allowing pivotal movement of the levers with respect to each other, and a plurality of prosthesis installation assemblies. Each assembly is adapted to be slidably disposed between the levers and movable between a first, proximal position and a second, distal portion. A handle portion can be provided on each assembly for moving the prosthesis installation assembly between the first and second positions. Each assembly further includes a distal prosthesis effecting element adapted to place a prosthesis between adjacent bone structures.

In one embodiment, one of the prosthesis installation assemblies includes a pusher block having a proximal end, a distal end, and a bore extending therethrough, a pusher rod slidably disposed between the levers and extending through the bore in the pusher block, and a grasping element effective to releasably engage a prosthesis. In another embodiment, one of the prosthesis installation assemblies includes a pusher rod having a proximal handle portion and a distal portion having a distal tip adapted to positively engage a prosthesis. A pusher block can be provided having a bore extending therethrough and adapted to receive a distal portion of the pusher rod. In yet another embodiment, one of the prosthesis installation assemblies can include a pusher rod having an externally threaded first distal portion and an externally threaded second distal portion. The second distal portion has a diameter greater than the first distal portion, and is positioned proximal to the first distal portion. The assembly further includes a pusher block having a bore extending entirely therethrough having a threaded proximal opening that is threadingly matable with the second distal portion of the rod, and a distal opening having a diameter less than the diameter of the second distal portion of the rod. A chamber having a diameter greater than the diameter of the second distal portion of the pusher rod is disposed between the first and second openings of the pusher block. In other aspects, one of the prosthesis installation assemblies can include a pusher block having a bore extending therethrough, a pusher rod extending through the bore in the pusher block, and a plurality of connector elements having a proximal portion adapted to mate to a distal tip of the pusher rod, and a distal portion adapted to mate to a prosthesis.

The installation tool of the invention can be used in the following manner. Once the natural, damaged disc tissue is removed from a patient and the area is prepared to receive an artificial prosthesis, such as an artificial disc, the artificial disc is loaded between the levers of the installation tool so that a posterior side of the disc abuts a distal end of the pusher block.

The distal tip of the levers is then positioned between the vertebral bodies such that the outwardly facing surfaces of each lever contacts opposed vertebral bodies. Once this position is achieved, the pusher rod is advanced distally, causing the pusher block and the artificial disc to likewise move distally along the inner surfaces of the levers. As the artificial disc and the pusher rod move distally, or forward, the levers separate and also cause vertical separation of the adjacent vertebral bodies. To achieve the proper position of the artificial disc, the distal facing surfaces of the pusher block should contact the vertebral bodies. Once such contact is achieved between the distal facing surfaces of the pusher block and the vertebral bodies, the artificial disc is properly positioned. This tool thus enables the proper positioning of the artificial disc between the vertebral bodies, without over-insertion or under-insertion of the artificial disc, while minimizing the degree of distraction of the vertebrae. To remove the tool, a slaphammer or similar device can be used to apply a proximally directed force to the tool to extract the blade tips without removing the implant.

#### BRIEF DESCRIPTION OF THE DRAWINGS

The invention will be more fully understood from the following detailed description taken in conjunction with the accompanying drawings, in which:

FIG. 1 is a perspective view of an installation tool according to the present invention;

FIG. 2 is a side, elevation view of the tool shown in FIG. 1;

FIG. 3 is a top view of the tool shown in FIG. 1;

FIG. 3A is a perspective view of an installation tool having curved distal blade tips according to another embodiment of the present invention;

FIG. 3B is a side view illustration of another embodiment of an installation tool according to the present invention;

FIG. 4 is a sectional view of the tool shown in FIG. 2, at line 4-4;

FIG. 5 is a top view of a portion of the tool shown in FIG. 2, at line 5-5;

FIG. 6 is an exploded view of a proximal portion of the tool shown in FIG. 1;

FIG. 7 is an exploded view of a portion of the tool shown in FIG. 1;

FIG. 7A is an enlarged view of another embodiment of a pusher block of the tool shown in FIGS. 1-3B;

FIG. 8 is a side view of a portion of a medical installation tool according to yet another embodiment;

FIGS. 8A-8D illustrate, sequentially, the operation of the installation tool according to the present invention during the installation of an artificial disc;

FIG. 9 is a side-elevation view of one embodiment of an installation tool according to the present invention in an initial, unlocked position;

FIG. 10 is a side view of the installation tool of FIG. 9 in a final, locked position;

FIG. 11 is a sectional view of the tool shown in FIG. 9, at line 11-11;

FIG. 12 is perspective view of a pusher block useful with the tool of the present invention;

FIG. 13 is a perspective view of a further embodiment of an installation tool according to the present invention;

FIG. 14 is an exploded, perspective view of a portion of the installation tool shown in FIG. 13;

FIG. 15A is a side, elevation view of a portion of the distal end of the installation tool of FIG. 13 in a first position;

FIG. 15B is a side, elevation view of a portion of the distal end of the installation tool of FIG. 13 in a second position;



## 5

FIG. 16 is an exploded side, perspective view of one embodiment of a connector element for use with a medical installation tool;

FIG. 17 is an exploded perspective view of a slaphammer instrument for use with a medical installation tool of the present invention;

FIG. 18 is a side view illustration of a portion of a pusher rod for use with a medical installation tool according to the present invention;

FIG. 19A is a cross-sectional side view of a pusher block component of the medical installation tool shown in FIG. 8; and

FIG. 19B is a plan view of the proximal end of the pusher block of FIG. 19A.

## DETAILED DESCRIPTION OF THE DRAWINGS

The present invention provides an installation tool that is useful for the efficient and effective placement of an article, such as an artificial disc or cage, between adjacent vertebral bodies. The installation tool can be provided as a kit having modular components which allow the surgeon to select from among a variety of components to assemble an installation tool that is optimized for its intended use. Although the invention is described primarily with reference to being used to install an artificial disc between adjacent vertebral bodies, it is understood that the installation tool of the invention can be used to place other elements between vertebral bodies, or in other locations within a patient's body. Exemplary elements that can be placed between vertebral bodies include, but are not limited to interbody cages, fusion devices, spacers, grafts, and the like.

As shown in FIGS. 1-3B, the installation tool 10 of the invention includes opposed levers 12, 14, each having a distal portion 12A, 14A and a proximal, handle portion 12B, 14B. Disposed between the levers 12, 14 is a fulcrum 16 and pusher block 18, which is disposed distally of the fulcrum 16. The pusher block 18 includes a bore extending at least partially therethrough and it is selectively movable from an initial position distal of the fulcrum 16 to a final location adjacent a distal end of the levers. A pusher rod 20, which facilitates selective movement of the pusher block, has a proximal handle end 20B and a distal end 20A extending into the bore in the pusher block. Although not part of the invention, a prosthesis, such as an artificial disc 24, is positioned between the levers, distal of the pusher block 18.

Preferably the levers 12 and 14 are elongate elements that are mirror images of each other. There is no absolute top or bottom of the tool 10 since it is possible to use either surface as a "top" surface. For ease of reference, however, levers will sometimes be described herein with reference to an illustrated orientation. For example, lever 12, and components thereof, may sometimes be referred to as the top, upper, or superior lever while lever 14 may sometimes be referred to as the bottom, lower, or inferior lever.

With further reference to FIGS. 1-3B, the levers 12, 14 include distal 12A, 14A and proximal 12B, 14B ends. The proximal end 12B, 14B of each lever may be of a shape that facilitates convenient grasping and handling of the tool. The proximal end of each lever may comprise approximately one-half of the length of each lever. In one embodiment, a shoulder 26 marks the end of the proximal portion of the tool and the beginning of the distal portion of the tool. As shown in FIGS. 1 and 3, the proximal portion of each lever preferably has a width ( $W_p$ ) that is greater than the width ( $W_d$ ) of the distal portion of each lever.

## 6

The proximal portion 12B of each lever may include an indented region 28 for receiving the fulcrum 16. As shown in FIGS. 1 and 6, the indented region 28 is in the form of a substantially rectangular cut-out formed on both sides of levers 12B, 14B. This indented region 28 enables the levers to conveniently seat the fulcrum 16, as described below. The recessed region 28 is preferably formed slightly proximally of the shoulder 26. In one embodiment the distal portion of the recessed region 28 begins approximately 10 to 100 mm proximally of shoulder 26. The recessed region 28 generally has a length in the range of about 10 to 40 mm and is recessed by about 1 to 40 mm.

The proximal region of each lever 12B, 14B may also include a bore 30A, 30B which is adapted to seat a bolt 32 that enables control of the spacing between levers so that the pusher block accurately engages the metal portion of the artificial disc. As shown in FIG. 6, bolt 32 includes a head 34 and shaft 35 having a threaded region 36. Preferably, internal threads 36 are formed within bore 30A.

The distal portion of each lever 12A, 14A features side surfaces 46, 48, outwardly facing surfaces 38, 40 (illustrated as top and bottom surfaces in FIG. 6, respectively), and inwardly facing surfaces 42, 44 upon which the artificial disc 24 can ride during an installation procedure. The outwardly and inwardly facing surfaces of the lever preferably are substantially smooth. The inwardly facing surfaces 42, 44 can, however, include surface features effective to mate to complementary surface features formed on the implant. For example, each lever 12, 14 can include a rail (not shown) formed in the inwardly facing surface 42, 44 that is effective to be slidably disposed within a corresponding groove or channel formed in the implant. As a result of the surface features formed on the inwardly facing surfaces 42, 44 of the levers 12, 14, the width ( $W_d$ ) of the distal portion of each lever can be substantially the same as or even greater than the width ( $W_p$ ) of the proximal portion of each lever.

The distal portions 12A, 14A of the levers 12, 14 can also have blade tips 50A, 50B formed at the distal ends of the levers. The blade tips are sized and configured to facilitate their placement between vertebral bodies 201, 202. The outwardly facing surfaces 52A, 52B of blade tips may be configured to have surfaces that are beveled or radiused. In one embodiment illustrated in FIG. 3A, the blade tips 12<sub>c</sub>C, 14<sub>c</sub>C can be substantially curved or angled in a superior or inferior direction to facilitate placement of the blade tips 12<sub>c</sub>C, 14<sub>c</sub>C between adjacent vertebrae. In the illustrated embodiment, the distal tip of the rod 20<sub>c</sub> includes a spring 2 which allows the distal portion of the rod 20<sub>c</sub> to conform or bend to the shape of the curved blade tips 50A, 50B. The proximal end 4 of the spring 2 can be threadingly mated to or otherwise attached to the distal end of the rod 20<sub>c</sub>, and the end 6 of the spring 4 can be attached to the proximal end of the pusher block 18<sub>c</sub>. Preferably, the pusher block 18<sub>c</sub> includes a protrusion adapted to extend into the bore in the spring 4 to mate the pusher block 18<sub>c</sub> to the spring 4.

The thickness of the levers, measured at the blade tips when the tool is closed, as shown in FIG. 1, can be considerably less than the thickness of the levers measured near the fulcrum between outwardly facing surfaces 38, 40 when the tool is in the closed position. Preferably, the thickness measured at the blade tips is in the range of about 0.5 to 2 mm. A portion of each lever 12A, 14A, disposed adjacent a proximal end of the blade tips 50A, 50B, can include a stop surface 54. The stop surface 54, which is substantially vertically oriented and distally facing, is adapted to abut a vertebral body during a surgical procedure for installing an element, such as an artificial disc, between adjacent vertebral bodies. The stop sur-

face **54** may assume a variety of configurations. In one embodiment, shown in FIGS. **2** and **8A-9**, the stop surface has a substantially concave profile when viewed in the vertical plane.

As shown in FIGS. **6-7** the side surfaces of the distal portions **12A, 14A** of the levers **12, 14** may have opposed rails **56, 58**, with a recessed track **60** disposed therebetween. The formation of such recessed tracks **60** within the distal side walls of levers **12, 14** causes these elements to have a profile that, as shown in FIGS. **4** and **7**, is substantially I-shaped or T-shaped. The rails **56, 58** and track **60**, as discussed below, can be effective to facilitate smooth and efficient movement of the pusher block.

One of ordinary skill in the art will appreciate that the size and shape of the levers may vary. Generally, however, the overall length of the levers is about 200 to 400 mm, with proximal portion **12B, 14B** (proximal end to shoulder **26**) having a length of about 100 to 300 mm and the distal portion **12A, 14A** (shoulder **26** to blade tips) having a length of about 100 to 300 mm.

In one embodiment, illustrated in FIGS. **1-3** and **6**, the fulcrum **16** is substantially a block-like object having substantially vertical side walls **62**. The upper and lower surfaces **64, 66** of fulcrum **16** include recesses or grooves **68**, each of which is defined by a base wall **70, 72** and opposed inner side walls **74**. A core section **78** lies between the base walls **70** and **72**. The core section **78** preferably includes a central bore **80** to allow passage of pusher rod therethrough. In an exemplary embodiment each base wall **70, 72** includes a mounting post **82**. As shown in FIG. **6**, a biasing element **84'**, such as a coil spring, may be placed upon each of mounting posts **82** and the mounting posts, in turn, positioned within the bores **31A, 31B** of levers **12, 14**.

The fulcrum **16** may assume virtually any size and shape that is able to render it effective to separate a substantially intermediate portion of levers while allowing the proximal, handle portion **12B, 14B** to be closed together and result in the opening or separation of the distal portion **12A, 14A**. Generally, the height of the vertical side walls **62** is in the range of about 20 to 70 mm while the height of the core section **78** (shown in FIG. **7**) is in the range of about 5 to 30 mm. The length of the core section **78** may be about 5 to 40 mm.

One of ordinary skill in the art will further appreciate that the fulcrum may take on a variety of other shapes, sizes and mounting configurations. The embodiment described above is intended to represent one exemplary fulcrum design and mounting configuration.

The bolt **32**, as noted above, can be used to adjust the height/spacing of the levers. One of bores **30A, 30B**, has internal threads **37** that mate with threaded portion **36** of bolt **32**. Tightening or loosening of the bolt will result in increasing or decreasing the spacing/distance between the levers.

The pusher block **18**, as illustrated in FIG. **7**, may be in the form of a substantially block-like object having vertical side walls **84** that define upper and lower recesses **86, 88** wherein each recess is defined by a base wall **90** and opposed inwardly facing side walls **92**. Each inwardly facing side wall **92** preferably includes a guide post **94** that is matable within recessed tracks **60** formed in the distal portion of levers **12A, 14A**.

In another embodiment, shown in FIG. **7A**, each inwardly facing side wall **92'** of pusher block **18<sub>a</sub>** includes a rail **95** extending from the proximal end to the distal end of the pusher block **18<sub>a</sub>**. Each rail **95** forms a groove or track **97** that is matable with rail **56** or rail **58** of each lever **12, 14**. The rail **95** and track **97** of top and bottom sides of the pusher block **18<sub>a</sub>** limit movement of the levers **12, 14** with respect to each

other. In use, proximal movement of the pusher block **18<sub>a</sub>** is effective to cause the blade tips **50A, 50B** to move to the closed position, and to cause the proximal portion of the levers **12, 14** to be fully disposed within the recesses **68** (FIG. **6**) of the fulcrum **16**. Once the pusher block **18** is positioned just distal to the fulcrum **16**, the levers **12, 14** are in effect locked in the closed position.

Referring back to FIG. **7**, the core section **91** of the pusher block **18** is disposed between upper and lower base walls **90** and includes a proximally facing wall **96** and a distally facing wall **97**. In one embodiment, the height of the core section **91** is less than the height of the prosthesis to be installed, thus enabling inwardly facing surfaces **42, 44** of levers **12, 14** to contact the prosthesis. Alternatively, as shown in FIG. **8**, the core section **91** can have a height  $h_c$  that is slightly greater than the height of the prosthesis **24<sub>b</sub>** to prevent the prosthesis **24<sub>b</sub>** from contacting the inwardly facing surface **42, 44** of each lever **12<sub>b</sub>, 14<sub>b</sub>**. Thus, the prosthesis **24<sub>b</sub>** is spaced apart from the levers **12<sub>b</sub>, 14<sub>b</sub>** when mated to the pusher block **18<sub>b</sub>** or pusher rod **20<sub>b</sub>**. The distally facing wall of the pusher block **18** can have a shape which conforms to the shape of a prosthesis. In an exemplary embodiment, several pusher blocks **18, 18<sub>a</sub>, 18<sub>b</sub>** can be provided, each having a different size and/or shape that is optimized for use with a particular prosthesis or patient.

As noted above, a pusher rod **20** may be utilized to actuate pusher block **18**. The pusher rod **20** is preferably an elongate, cylindrical member having a proximal end **20B** and a distal end **20A**. The rod is adapted to be positioned between the proximal ends **12B, 14B** of the levers **12, 14** so that it extends into or through the bore **80** in fulcrum **16**. The rod **20** can be adapted to mate to the pusher block **18** such that forward and rearward movement of the pusher rod will directly move the pusher block. Alternatively, the pusher block **18** can include a bore extending entirely therethrough, and the rod **20** can be disposed through the bore to mate directly to a prosthesis, or to mate to a connector element which, in turn, mates to a prosthesis.

The pusher rod **20** can optionally include a stop feature to prevent the levers **12, 14** from being removed from the recessed formed in the pusher block. As shown in FIGS. **3A** and **3B**, the rod **20, 20<sub>c</sub>** can include a stop surface **17** which abuts the proximal opening of the bore **80** in the fulcrum **16**, thereby preventing proximal movement of the levers **12, 14** and fulcrum **16**. The stop surface **17** can be formed by a change in diameter of the pusher rod **20, 20<sub>c</sub>**, such that the proximal portion of the rod has a diameter greater than the distal portion of the rod **20, 20<sub>c</sub>**, and greater than the bore in the pusher block **18**. Alternatively, the stop surface **17** can be formed from an annular flange or similar protruding structure.

The pusher block **18** and pusher rod **20** can include a variety of features, e.g. connector elements, for joining the block **18** to the rod **20**, or for mating the rod **20** and/or the block **18** to a prosthesis **24**. By way of non-limiting example, FIG. **7** illustrates one embodiment in which the proximal end of the pusher block **18** facing wall includes a blind bore **98** having internal threads **100**. The threads are adapted to mate with complimentary threads **102** formed on a distal end **20A** of the pusher rod **20**, thereby allowing the pusher rod **20** to positively engage the pusher block **18**. The distal facing wall **97** of the pusher block may include a recessed region **104** that is adapted to nest artificial disc **24**. As illustrated, the recessed region **104** has dimensions that enable the artificial disc to fit loosely therein. One of ordinary skill in the art will appreciate that the recessed area should have dimensions slightly greater than the dimensions of the disc so as to avoid a frictional fit that may inhibit free release of the disc from the tool. FIG. **12**

illustrates one embodiment of a recessed region **104** having a contact wall **106** that has a generally arcuate shape. Preferably, contact wall **106** is substantially concave and well suited to maintaining contact over a substantial surface area of a generally curved (convex) posterior surface of an artificial disc **24**.

FIGS. **8**, and **18-19B** illustrate another embodiment of a connector element for joining the pusher rod **20<sub>b</sub>** to the pusher block **18<sub>b</sub>**, and optionally to a prosthesis **24<sub>b</sub>**. As shown in FIGS. **19A** and **19B**, the pusher block **18<sub>b</sub>** includes a bore **401** having a proximal opening **406**, a distal opening **405**, and a chamber **408** extending therebetween. The proximal and distal openings **406**, **405** preferably each have substantially the same diameter, and preferably each have a diameter less than the diameter of the chamber **408**. As shown in FIG. **19B**, the proximal opening **406** includes a threaded region **403** which mates to a corresponding threaded region **411** formed on the rod **20<sub>b</sub>** (FIG. **18**). The proximal opening **406** can, however, include a variety of engagement elements such as, for example, an o-ring which mates to a corresponding groove formed on the rod **20<sub>b</sub>**. The distal opening **405** does not include threads, and thus is effective to prevent the threaded portion of the rod **20<sub>b</sub>** from being threaded through the distal opening **405**. The proximal opening **406** can also include a tapered portion **409** for abutting a corresponding tapered portion **410** formed on the rod **20<sub>b</sub>**.

FIG. **18** illustrates a pusher rod **20<sub>b</sub>** that is suitable for use with the embodiment of pusher block **18<sub>b</sub>** shown in FIGS. **19A** and **19B**. Pusher rod **20<sub>b</sub>** includes a distal tip **413**, a connector segment **412** extending proximally from the distal tip **413**, and an annular flange **411** having a distal end **418** integral with the connector segment **412** and a proximal end **416** mated to the rod **20**. The proximal and distal ends **416**, **418** can be tapered to facilitate insertion and removal of the rod **20<sub>b</sub>** from the pusher block **18**. The distal tip **413** of the rod **20<sub>b</sub>** can mate to a prosthesis, and thus can include an engagement element. As shown in FIG. **18**, the distal tip **413** is threaded **415** to mate with corresponding threads formed in a bore in a prosthesis.

In use, the rod **20<sub>b</sub>** is inserted into the proximal opening **406** of the pusher block **18**. The distal tip **413** and connector segment **412** can be inserted through the bore until the threaded annular flange **411** engages the threaded region **403** of the pusher block **18<sub>b</sub>**. The flange **411** can then be rotated and thus threaded through the bore **403** to position the flange **411** in the chamber **408**. Further distal movement of the rod **20<sub>b</sub>** will insert the distal tip **413** and a substantial portion of the connector rod **412** through the distal opening **405** of the pusher block **18<sub>b</sub>**. The lack of threads, and the size differential, in the distal opening **405** will, however, prevent the annular flange **411** from exiting the chamber. Once the annular flange **411** is positioned in the chamber, the rod **20<sub>b</sub>** is free to rotate. The rod **20<sub>b</sub>** can then be rotated to positively engage a prosthesis, or to detach the rod from a prosthesis. In an exemplary embodiment, the threads formed on the annular flange **411** are oriented in a direction opposite to the threads **415** formed on the distal tip **413**. This allows the rod **20<sub>b</sub>** to be detached from a prosthesis without allowing the rod **20<sub>b</sub>** to be threadingly removed through the proximal opening **406**.

A person having ordinary skill in the art will appreciate that the annular flange **411**, and the distal tip **413** can employ a variety of engagement elements other than threads. For example, other locking elements include snap-fit engagements, frictional engagements, bayonet-type locks, leuer locks, or any other type of connector.

FIG. **16** illustrates another embodiment of a connector element for joining the pusher block **18<sub>d</sub>** to a prosthesis **600**.

As shown, a grasper element **500** is provided for grasping a prosthesis **600**. The grasper **500** includes a proximal portion **502** and a distal portion **504**. The proximal portion **502** is elongate, having a substantially cylindrical cross-section with an outer diameter *d*, and a bore **506** extending therethrough along the longitudinal axis *l* of the instrument. The bore **506** is adapted to matingly engage the distal end **20A** of the rod **20**, and thus can include internal threads that threadingly receive the threaded distal end **20A** of the rod **20**. A person having ordinary skill in the art will appreciate that a variety of alternative engagement mechanisms can be provided for mating the grasper **500** to the rod **20**. The outer diameter *d* of the cylindrical proximal portion **502** should be less than the diameter of the bore **80<sub>d</sub>** in the pusher block **18<sub>d</sub>** to allow the proximal portion **502** to be inserted into the bore **80<sub>d</sub>**. The proximal portion **502** preferably includes a tapered region **505** which increases toward the distal portion **504**.

The distal portion **504** of the grasper **500** is oriented to extend in a direction substantially transverse to the longitudinal axis *l* of the instrument and includes first and second wing-like components **508**, **509**, each positioned on opposed sides of the longitudinal axis *l*, and separated from one another by a gap **513**. The first and second components **508**, **509** are not attached to each other, but include a proximally extending portion **510**, **511** which mates to the proximal portion **502**. The proximally extending portions **510**, **511** taper inwardly toward the proximal portion **502**. As a result, the grasper **500** incrementally increases in diameter *d* toward the distal portion **504** of the grasper **500**. In an exemplary embodiment, the gap **513** allows the first and second components **508**, **509** to be pinched together.

The first and second components **508**, **509** each include a distally facing wall **520**, **521**. The walls **520**, **521** can have a shape that conforms to the shape of a prosthesis, and preferably the walls are slightly concave to fit around a substantially cylindrical or disc-shaped prosthesis **600**, as shown. Each component **508**, **509** can include a protruding element **515**, **516** disposed on the distally facing wall **520**, **521** that is effective to engage a prosthesis **600**. The protruding elements **515**, **516** can be, for example, triangle-shaped, diamond shaped, or hook-like members which, when placed into openings **518** formed in the prosthesis **600**, are effective to engage the prosthesis **600**.

In use, the grasper **500** is inserted into the bore **80<sub>d</sub>** in the pusher block **18<sub>d</sub>** and it is mated to the rod **20**. The protruding elements **515**, **516** are inserted into the openings **518** formed in the prosthesis **600**, and the rod **20** is rotated to engage the grasper **600**, thereby moving the grasper **600** proximally. As the grasper **600** is pulled in a proximal direction by the rod **20**, the tapered portion of the grasper **500** is pulled into bore **80<sub>d</sub>**, thereby causing the first and second components **508**, **509** to be pinched together. As a result, the protruding elements **515**, **516** grasp and retain the prosthesis **600**. The prosthesis **600** can then be positioned between adjacent vertebrae and, once positioned, the rod **20** can be rotated in the opposite direction to release the grasper **500**, thereby allowing the first and second components **508**, **509** to return to their separated state, thus releasing the prosthesis **600**.

In an exemplary embodiment, the pusher block **18<sub>d</sub>** includes a recessed region **19** formed in each of the side walls of the pusher block **18<sub>d</sub>** to allow the grasper **500** to be inserted into the bore **80<sub>d</sub>**. The first and second components **508**, **509**, when mated to the pusher block **18<sub>d</sub>**, sit within the recessed region **19**. The rod **20** preferably includes a stop surface (not shown) to prevent further insertion of the rod **20** through the bore **80<sub>d</sub>** in the pusher block **18<sub>d</sub>**. The stop surface should be

## 11

positioned to allow a distal portion of the rod **20** to extend through the bore **80<sub>a</sub>** to engage the grasper **500**.

The depth of insertion of the cage **600** between the vertebral bodies is dependant on the length of the grasper **500** and the depth of the recessed portion **19**. For example, the length of the grasper **500** and the depth of the recessed portion **19** can be substantially the same such that the distal end of the pusher block is aligned with the distal end of the grasper. In use, the distal ends of the pusher block and the grasper align with the outer edge of the adjacent vertebrae. As a result, the implanted disc is substantially aligned with the outer edge of the adjacent vertebrae. Alternatively, the grasper **500** can have a length greater than the depth of the recessed portion **19** such that the depth of insertion of the disc is substantially equal to the difference between the length of the grasper **500** and the depth of the recessed portion **19**.

FIGS. **9** and **10** illustrate an alternative embodiment in which installation tool **10'** includes a locking mechanism **108** in the proximal, handle portion **12B'**, **14B'** of levers **12'**, **14'**. The locking mechanism, which may comprise a latch and groove, simply secures the proximal handle portion of levers in a desired position and prevents complete separation of these elements. FIG. **9** illustrates the tool **10'** in a position in which the proximal portion **12B'**, **14B'** of the levers is open or unactuated. The locking mechanism **108** prevents further opening or separation of the proximal portions **12B'**, **14B'** of the levers. However, as shown in FIG. **10**, the locking mechanism still allows the handles **12B'**, **14B'** to be actuated or closed together in order to operate the tool and install a prosthesis, such as artificial disc **24**. One benefit of the locking mechanism **108** is that the disc is less likely to become inadvertently dislodged from the tool during pre-surgical installation manipulation of the tool.

FIG. **13** illustrates an embodiment of the invention in which installation tool **300** includes a plurality protrusions **302**, **304** formed on proximal or handle portions **312B**, **314B** of levers **312**, **314**. Preferably, the protrusions **302**, **304** are formed on lateral surfaces of the handle portions. In an exemplary embodiment two protrusions are formed on each of the top and bottom levers **312**, **314**. Although illustrated as being substantially cylindrical in shape, it is understood that protrusions **302**, **304** may take virtually any shape. Referring back to FIG. **3B**, for example, the proximal end **12B**, **14B** of the handles **12**, **14** can have a T-shape. The T-shape, or the protrusions, may be useful to facilitate extraction of the blade tips **350A**, **350B** using a tool such a slaphammer **800** or a slap fork (shown in FIG. **17**) The slap hammer **800** is positioned around the levers **12**, **14**, and slid proximally to apply a proximally directed force to the T-shaped handles, or to the protrusions **302**, **304**. The dimensions of T-shaped handles or the protrusions **302**, **304** may vary within a wide range. Generally, however, the T-shaped handles or protrusions **302**, **304** extend from the lateral surfaces of levers **312**, **314** by a distance of about 3 mm to 50 mm.

Although T-shaped handles and protrusions **302**, **304** are illustrated, one of ordinary skill in the art will readily appreciate that the handles can have a variety of configurations for allowing use of a slap hammer with the instrument.

With reference to FIGS. **13-15B**, the installation tool **300** may also include a feature which permits selective adjustment of blade tip length (i.e., the distance between the distal end **306** of blade tips **350A**, **B** and stop surface **354**). In such an embodiment the distal portion of each of the levers **312A**, **314A** has a stop member component **307** and a blade member component **308**, which are longitudinally separable with respect to each other. The separability of components **307** and

## 12

**308** permits the blade tip length to be adjusted by varying the relative positions of components **307**, **308**.

As shown in FIGS. **13** and **14** tool **300** includes a junction box **309** which houses and secures the components **307**, **308**. A portion **307A** of the stop member component **307**, which mates with the inner surface of the cover **320** of the junction box **309**, includes a series of grooves **310** separated by raised ridges **311**. Similarly, the abutting, inner surface of the cover **320** of the junction box **309** includes grooves and ridges **310**, **311** as well. As further illustrated, the cover **320** is secured to levers **312**, **314** by suitable fasteners, such as screws **322**. Biasing elements, such as compression springs (not shown) are preferably used to bias the junction box to a position such that the grooves and ridges **310**, **311** of the cover **320** and the stop member component **307** mate with and remain firmly secured to one another. As shown in FIG. **14**, suitable indicia **325** may be present on the stop member component **307** to indicate the position of the stop member component **307** with respect to the blade member component. Although FIG. **14** only illustrates, in detail, the configuration of lever **12**, it is understood that the same construction is used for lever **14**.

The result of this selective adjustability is shown in FIGS. **15A** and **15B**, in which the blade tip length is greater in FIG. **15A** than in FIG. **15B**.

FIGS. **1** and **8A-8D** sequentially illustrate the use of tool **10** for the installation of an artificial disc **24**. The tool is first assembled as shown in FIG. **1**, and with pusher block **18** positioned in its initial position such that its proximally facing wall **96** abuts shoulder **26**, the posterior surface **27** of the disc is placed against the distal facing wall **97** of the pusher block. With the handles **12B**, **14B** in the open position and the blade tips **50A**, **B** closed, the blade tips are wedged between adjacent vertebral bodies **201**, **202** to effect slight separation between at least the anterior portions of the vertebral bodies. The blade tips **50A**, **B** should be fully inserted between the vertebral bodies, as shown in FIG. **8A**, so as to enable the vertebral stop surface **54** to abut the posterior side **204** of the vertebral bodies **201**, **202**. The pusher rod **20** is then pushed forward, causing distal movement of the pusher block **18** and artificial disc **24**. The forward or distal movement of pusher block **18** and the artificial disc **24** also causes further separation of the blade tips **50A**, **B** and thus further separation of the vertebral bodies **201**, **202** as shown in FIG. **8B**. Advancement of the pusher block **18** and the artificial disc **24** continues until, as shown in FIG. **8C**, the disc is properly installed between adjacent vertebral bodies. FIGS. **8B** and **8C** illustrate that at all times separation of the vertebral bodies is only effected to the extent necessary to insert the disc. Excessive distraction or separation of the vertebral bodies does not occur because the separation of vertebral bodies is caused by the height of the pusher block.

The installation tool of the present invention can also be provided as a kit having modular components which allow the surgeon to select from among a variety of components to assemble an installation tool that is optimized for its intended use. The kit preferably includes several different rods, pusher blocks, and connectors elements, such as grasper **500**, each adapted to be used with a particular implant. For example, the kit can include three types of pusher blocks, each adapted to mate with a particular prosthesis. As shown in FIG. **16**, the pusher block **18<sub>a</sub>** can be used in combination with grasper **500** to insert a cage-type spacing prosthesis. Alternatively, as shown in FIG. **1**, pusher block **18** can be provided for inserting an artificial disc. A person having ordinary skill in the art will appreciate that the installation tool can include a variety of components having a combination of different features.

## 13

Moreover, the components can be adapted for use with particular types of prosthesis, or for use with other components.

One of ordinary skill in the art will appreciate further features and advantages of the invention based on the above-described embodiments. Accordingly, the invention is not to be limited by what has been particularly shown and described, except as indicated by the appended claims. All publication and references cited herein are expressly incorporated herein by reference in their entirety.

What is claimed is:

**[1.** A medical device installation kit, comprising:

a pair of opposed levers, each lever having a proximal handle portion and a distal portion;

a fulcrum disposed between the opposed levers for allowing pivotal movement of the levers with respect to each other; and

a plurality of prosthesis installation assemblies adapted to be slidably disposed between the levers and slidably coupled to the fulcrum such that each prosthesis installation assembly is movable between a first, proximal position and a second, distal position, each assembly including a handle portion effective to move the prosthesis installation assembly between the first and second positions, and a distal prosthesis effecting element adapted to place a prosthesis between adjacent bone structures.]

**[2.** The medical device installation kit of claim 1, wherein one of the prosthesis installation assemblies comprises:

a pusher block having a proximal end, a distal end, and a bore extending therethrough;

a pusher rod slidably disposed between the levers and extending through the bore in the pusher block; and  
a grasping element effective to releasably engage a prosthesis.]

**[3.** The medical device installation kit of claim 2, wherein the grasping element has an elongate proximal portion adapted to fit within the bore of the distal end of the pusher block, and a distal portion having opposed first and second components which are movable between a first, open position, and a second, closed position that is effective to engage a prosthesis.]

**[4.** The medical device installation kit of claim 3, wherein a distal end of the rod threadingly engages the bore of the pusher block and wherein rotation of the rod in a first direction is effective to cause the elongate proximal portion of the grasping element to move proximally within the bore of the pusher block and move the first and second components to the second, closed position while rotation of the rod in a second direction is effective to cause the elongate proximal portion of the grasping element to move distally out of the bore of the pusher block and move the first and second components to the first, open position.]

**[5.** The medical device installation kit of claim 1, wherein one of the prosthesis installation assemblies comprises a pusher rod having a proximal handle portion, and distal portion having a distal tip adapted to positively engage a prosthesis.]

**[6.** The medical device installation kit of claim 5, wherein the prosthesis installation assembly further includes a pusher block having a proximal end, a distal end, and a bore extending therethrough, the distal portion of the pusher rod extending through the bore in the pusher block.]

**[7.** The medical device installation kit of claim 1, wherein one of the prosthesis installation assemblies comprises:

a pusher rod having an externally threaded first distal portion and an externally threaded second distal portion, the second distal portion having a diameter greater than a

## 14

diameter of the first distal portion and being positioned proximal to the first distal portion;

a pusher block having a bore extending entirely there-through having a threaded proximal opening that is threadingly matable with the second distal portion of the rod, and a distal opening having a diameter less than the diameter of the second distal portion of the rod; and  
a chamber disposed between the proximal and distal openings and having a diameter greater than the diameter of the second distal portion of the rod.]

**[8.** The medical device installation kit of claim 7, wherein the rod is freely rotatable when the second distal portion is disposed within the chamber of the pusher block.]

**[9.** The medical device installation kit of claim 8, wherein the first distal portion of the rod is adapted to positively engage a prosthesis.]

**[10.** The medical device installation kit of claim 1, wherein one of the prosthesis installation assemblies comprises:

a pusher block having a proximal end, a distal end, and a bore extending therethrough, the pusher block being slidably disposed between the levers;

a pusher rod having a proximal, handle portion and a distal portion extending through the bore in the pusher block; and

a plurality of connector elements having a proximal portion adapted to mate to a distal tip of the pusher rod and a distal portion adapted to mate to a prosthesis.]

**[11.** A medical device installation tool, comprising:

a pair of opposed levers, each having a proximal, handle portion and a distal portion;

a fulcrum disposed between the two levers and including an opening extending therethrough;

a pusher block having a proximal end, a distal end, and a bore extending at least partially therethrough, the pusher block being positioned between the two levers and slidably moveable between an initial location distal of the fulcrum and a final location adjacent a distal end of the levers; and

a pusher rod having a proximal, handle end, and a distal end, the pusher rod being slidably disposed through the fulcrum and the distal end of the pusher rod extending into the bore in the pusher block.]

**[12.** The medical device installation tool of claim 11, wherein the bore is a blind bore and the distal end of the pusher rod mates with the blind bore in the pusher block.]

**[13.** The medical device installation tool of claim 11, wherein each lever includes a surface feature disposed between the proximal and distal portions thereof, the surface feature being effective to slidably mate to a complementary surface feature formed in a prosthesis.]

**[14.** The medical device installation tool of claim 11, wherein the bore extends entirely through the pusher block and the distal end of the pusher rod has a distal tip that is adapted to extend through the bore in the pusher block and that is effective to mate to a prosthesis.]

**[15.** The medical device installation tool of claim 14, wherein the pusher block has a height effective to separate the levers from a prosthesis such that, when the pusher rod is mated to a prosthesis, the levers are spaced apart from the prosthesis.]

**[16.** The medical device installation tool of claim 14, wherein the rod includes an externally threaded first distal portion and an externally threaded second distal portion, the second distal portion having a diameter greater than a diameter of the first distal portion and being positioned proximal to the first distal portion.]

15

**[17.** The medical device installation tool of claim 16, wherein:

the bore of the pusher block includes a threaded proximal opening that is threadingly matable with the second distal portion of the rod;

a distal opening of the pusher block having a diameter less than the diameter of the second distal portion of the rod; and

a chamber disposed between the proximal and distal openings, the chamber having a diameter greater than the diameter of the second distal portion of the rod.]

**[18.** The medical device installation tool of claim 17, wherein the rod is freely rotatable when the second distal portion is disposed within the chamber of the pusher block.]

**[19.** The medical device installation tool of claim 17, wherein the threaded first distal portion of the rod is threaded in a direction opposite to the direction of the threads of the threaded second distal portion.]

**[20.** The medical device installation tool of claim 11, wherein the bore extends entirely through the pusher block and a distal tip of the pusher rod is adapted to extend through the bore in the pusher block, the distal tip of the pusher rod being further adapted to mate to a grasping element effective to releasably engage a prosthesis.]

**[21.** The medical device installation tool of claim 20, further comprising a grasping element that has an elongate proximal portion with a bore formed therein and a distal portion that is effective to releasably engage a prosthesis, the proximal portion having an outer diameter that is adapted to fit within the bore of the distal end of the pusher block.]

**[22.** The medical device installation tool of claim 21, wherein the distal portion of the grasping element includes opposed first and second components that are movable between a first, open position, and a second, closed position that is effective to engage a prosthesis.]

**[23.** The medical device installation tool of claim 22, wherein the distal end of the rod threadingly engages the bore of the grasping element, and wherein rotation of the rod in a first direction is effective to cause the elongate proximal portion of the grasping element to move proximally within the bore of the pusher block and move the first and second components to the second, closed position while rotation of the rod in a second direction is effective to cause the elongate proximal portion of the grasping element to move distally out of the bore of the pusher block and move the first and second components to the first, open position.]

**[24.** The medical device installation tool of claim 23, wherein the first and second components each include at least one surface feature effective to engage a prosthesis.]

**[25.** The medical installation tool of claim 11, wherein the bore extends entirely through the pusher block and a distal tip of the pusher rod is adapted to extend through the bore in the pusher block, the distal tip of the pusher rod being further adapted to positively engage a prosthesis.]

**[26.** The medical device installation tool of claim 11, wherein the pusher block has upper and lower recesses, each adapted to seat one of the levers, each of the upper and lower recesses including opposed, substantially vertical walls separated by a substantially horizontal base wall, the vertical walls each including a rail extending between the proximal and distal ends of the pusher block and effective to retain the levers.]

**[27.** The medical device installation tool of claim 11, wherein the handle portion of each lever is substantially T-shaped.]

16

**[28.** The medical device installation tool of claim 11, wherein the pusher rod includes a stop member effective to limit advancement of the pusher rod through the opening in the fulcrum.]

**[29.** The medical device installation tool of claim 11, wherein the distal portion of each lever includes a curve tip.]

*30. A method of installing an implant, comprising: inserting distal tips of a pair of opposed levers between adjacent vertebral bodies, the distal tips being movable relative to one another between a closed position and an open position; and*

*advancing a pusher rod disposed between the pair of opposed levers distally to advance a pusher block distally and to move an implant engaged by the pusher block from an initial proximal location to a final location adjacent to the distal tips and between the adjacent vertebral bodies, the pusher block being coupled to a distal end of the pusher rod and disposed between the pair of opposed levers, and the pusher block having projections that slide within respective tracks formed in the pair of opposed levers as the pusher block is advanced distally.*

*31. The method of claim 30, wherein advancing the pusher block causes the distal tips to move to an open position and to distract the adjacent vertebral bodies.*

*32. The method of claim 30, wherein inserting the distal tips comprises advancing the distal tips distally between the adjacent vertebral bodies until stop surfaces of the distal tips abut the adjacent vertebral bodies.*

*33. The method of claim 30, wherein inserting the distal tips effects a separation of the adjacent vertebral bodies.*

*34. A method of installing an implant, comprising: inserting distal tips of a pair of opposed levers between adjacent vertebral bodies, the pair of opposed levers being coupled to one another adjacent a proximal end thereof and being movable at a distal end thereof between a closed position and an open position; and advancing an implant having first and second surface features formed thereon by sliding the and first and second surface features along complementary surface features formed on inwardly facing surfaces of the opposed levers, the implant being engaged and advanced by a pusher component positioned between the pair of opposed levers such that projections of the pusher component slide in engagement with the opposed levers to maintain alignment between the pusher component and the opposed levers.*

*35. The method of claim 34, wherein the surface feature on each lever extends between the proximal and distal ends of the lever.*

*36. The method of claim 34, wherein the surface feature on each lever comprises a rail, and the first and second surface features on the implant comprise first and second channels formed in the implant.*

*37. The method of claim 34, further comprising moving the levers from the closed position to the open position to distract the adjacent vertebral bodies by moving the pusher component distally towards the distal ends of the opposed levers.*

*38. The method of claim 34, wherein the projections comprise a plurality of posts extending from the pusher block, each post being complementary to a track formed in each lever such that the post is configured to slide along the track to facilitate movement of the pusher block with respect to the opposed levers.*

*39. The method of claim 34, wherein inserting the distal tips comprises advancing the distal tips distally between the adjacent vertebral bodies until stop features of the distal tips*

17

*engage the adjacent vertebral bodies to stop further distal movement of the opposed levers.*

*40. The method of claim 34, wherein inserting the distal tips effects a separation of the adjacent vertebral bodies.*

*41. A method of installing an implant, comprising:*

*inserting a distal tip of a first lever and a distal tip of a second lever between adjacent vertebral bodies, the first lever having proximal and distal ends and a first rail formed thereon, the second lever having proximal and distal ends and a second rail formed thereon and being coupled to the first lever at a location proximal to the distal tips of the first and second levers; and*

*sliding a pusher block disposed between the first and second levers and engaged with an implant towards the distal tips of the first and second levers to advance the implant distally relative to the first and second levers such that the first and second rails slide within first and second grooves formed in opposed surfaces of the implant.*

18

*42. The method of claim 41, wherein sliding the pusher block comprises sliding a first post of the pusher block along a first track formed in the first lever and sliding a second post of the pusher block along a second track formed in the second lever to move the pusher block with respect to the first and second levers.*

*43. The method of claim 41, wherein advancing the pusher block causes the distal tips to move to an open position and to distract the adjacent vertebral bodies.*

*44. The method of claim 41, wherein inserting the distal tips comprises advancing the distal tips distally between the adjacent vertebral bodies until stop surfaces of the distal tips abut the adjacent vertebral bodies.*

*45. The method of claim 41, wherein inserting the distal tips effects a separation of the adjacent vertebral bodies.*

\* \* \* \* \*

UNITED STATES PATENT AND TRADEMARK OFFICE  
**CERTIFICATE OF CORRECTION**

PATENT NO. : RE45,639 E  
APPLICATION NO. : 14/172631  
DATED : August 4, 2015  
INVENTOR(S) : Fraser et al.

Page 1 of 1

It is certified that error appears in the above-identified patent and that said Letters Patent is hereby corrected as shown below:

In the Specification

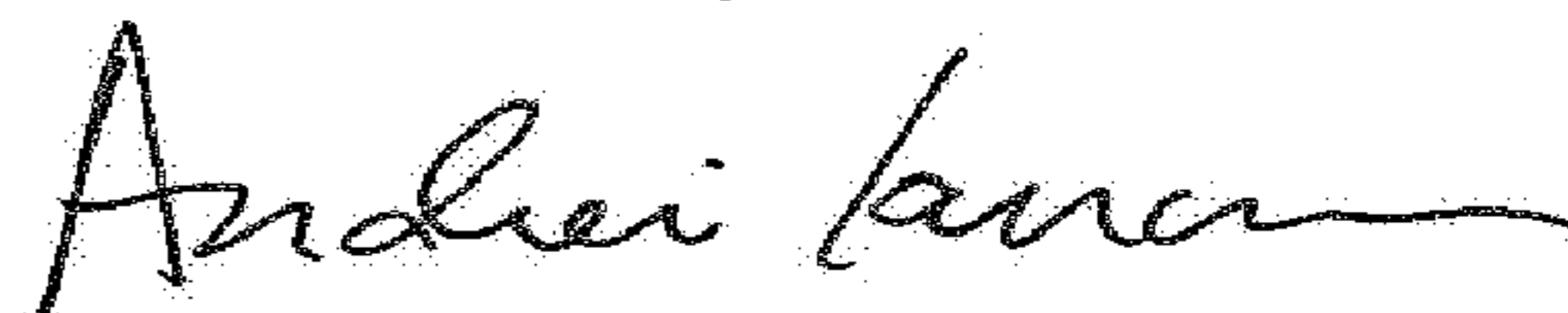
Column 1, beginning at Line 11, replace the heading "CROSS-REFERENCE TO RELATED APPLICATIONS" and the paragraph thereunder, with the following:

*Notice: More than one reissue application has been filed for the reissue of U.S. Patent No. 6,755,841. The reissue applications are U.S. Reissue Patent Application Serial No. 14/800,411, filed on July 15, 2015, now U.S. Reissue Patent No. RE46,410 E, issued May 23, 2017, which is a continuation reissue application of U.S. Reissue Patent Application Serial No. 14/172,631 (the present application), filed on February 4, 2014, now U.S. Reissue Patent No. RE45,639 E, issued August 4, 2015, which is a continuation reissue application of U.S. Reissue Patent Application Serial No. 13/331,675, filed on December 20, 2011, now U.S. Reissue Patent No. RE44,835 E, issued April 8, 2014, which is a continuation reissue application of U.S. Reissue Patent Application Serial No. 11/397,887, filed on March 29, 2006, now U.S. Reissue Patent No. RE43,317 E, issued April 17, 2012.*

**CROSS-REFERENCE TO RELATED APPLICATIONS**

*U.S. Patent Application Serial No. 10/011,264, filed December 7, 2001, now U.S. Patent No. 6,755,841, issued June 29, 2004, is a continuation-in-part of U.S. Patent Application Serial No. 09/566,514, filed May 8, 2000, now U.S. Patent No. 6,478,800, issued November 12, 2002, entitled "Medical Installation Tool," the entire contents of each of which is hereby expressly incorporated herein by reference.*

Signed and Sealed this  
Twelfth Day of June, 2018



Andrei Iancu  
Director of the United States Patent and Trademark Office