



US00RE45591E

(19) **United States**  
(12) **Reissued Patent**  
**McCarthy et al.**

(10) **Patent Number:** **US RE45,591 E**  
(45) **Date of Reissued Patent:** **Jun. 30, 2015**

(54) **SELECTIVELY-EXTENDABLE MODULAR LIGHTING FIXTURE AND METHOD**

(71) Applicant: **Kenall Manufacturing Co.**, Gurnee, IL (US)

(72) Inventors: **Charles A. McCarthy; James P. Kelly**

(73) Assignee: **Kenall Manufacturing Company**, Gurnee, IL (US)

(21) Appl. No.: **14/019,517**

(22) Filed: **Sep. 5, 2013**

**Related U.S. Patent Documents**

Reissue of:

(64) Patent No.: **6,984,055**  
Issued: **Jan. 10, 2006**  
Appl. No.: **10/943,692**  
Filed: **Sep. 17, 2004**

U.S. Applications:

(63) Continuation of application No. 10/156,423, filed on May 28, 2002, now abandoned.

(51) **Int. Cl.**  
**F21S 8/06** (2006.01)  
**F21S 2/00** (2006.01)  
**F21V 15/015** (2006.01)  
**F21V 21/005** (2006.01)

(Continued)

(52) **U.S. Cl.**  
CPC ..... **F21S 2/005** (2013.01); **F21V 15/015** (2013.01); **F21S 8/04** (2013.01); **F21Y 2103/00** (2013.01); **F21V 27/00** (2013.01); **F21V 21/005** (2013.01); **F21V 21/14** (2013.01); **F21S 2/00** (2013.01)

(58) **Field of Classification Search**  
CPC ..... F21S 2/005; F21V 21/005; F21V 15/015; F21V 27/00; F21Y 2103/00  
USPC ..... 362/217.1, 219, 223, 225  
See application file for complete search history.

(56) **References Cited**

U.S. PATENT DOCUMENTS

1,954,568 A 4/1934 Kenny  
2,323,002 A 6/1943 Baker

(Continued)

OTHER PUBLICATIONS

Undated purported Gardco fixture.

(Continued)

*Primary Examiner* — James Menefee

(74) *Attorney, Agent, or Firm* — Jansson Munger McKinley and Shape Ltd.

(57) **ABSTRACT**

A modular, linear-type lighting fixture may include an elongate housing having lengthwise ends, and a pair of endplates adapted for sealing attachment to either lengthwise end of the housing, each of the endplates having respective perimeter surfaces adapted for attachment to any one of a bridge adapted for angularly-directable extension of the housing, a bridge adapted for linear extension of the housing, and an endcap. A modular lighting fixture may include first and second elongate housings each having ends, pairs of endplates for being respectively mated with the first and second ends of the first and second elongate housings, the endplates each having a rim, and a bridge adapted for joining one of the endplates of the first elongate housing with one of the endplates of the second elongate housing by sealing cooperation with the respective rims thereof. A lighting fixture may have one or more isolated raceways therein.

**35 Claims, 8 Drawing Sheets**

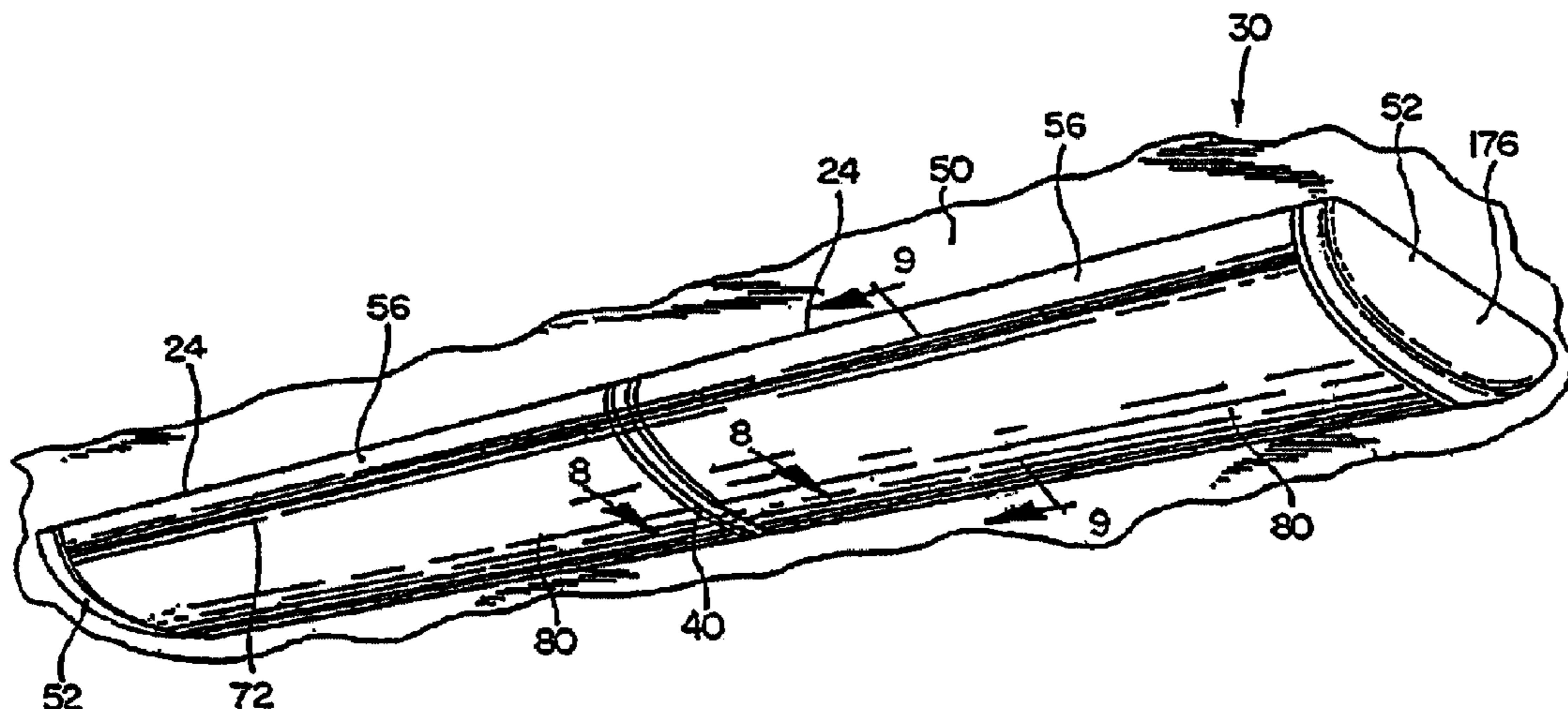

# US RE45,591 E

(51)	<b>Int. Cl.</b> <i>F21V 21/14</i> (2006.01) <i>F21S 8/04</i> (2006.01) <i>F21Y 103/00</i> (2006.01) <i>F21V 27/00</i> (2006.01)				4,670,823 A 6/1987 Kochi et al. 4,712,165 A 12/1987 Cetrone 4,716,671 A 1/1988 Gross 4,726,781 A * 2/1988 Bernhart et al. .... 439/228 4,748,548 A 5/1988 Barton 5,025,355 A 6/1991 Harwood 5,113,328 A 5/1992 Foster et al. D342,523 S 12/1993 Morgan et al. 5,386,353 A 1/1995 Battaglia 5,390,094 A 2/1995 Evanisko 5,404,279 A 4/1995 Wood 5,416,683 A 5/1995 McCarthy 5,422,800 A 6/1995 Entrop et al. 5,564,818 A 10/1996 Grossman 5,658,066 A * 8/1997 Hirsch ..... 362/219 5,658,067 A 8/1997 Engle et al. 5,702,176 A 12/1997 Engle 5,716,123 A 2/1998 Lamming 5,902,035 A 5/1999 Mui 6,186,642 B1 * 2/2001 Corcorran et al. .... 362/219 6,186,842 B1 2/2001 Hirschbold et al. 6,305,816 B1 10/2001 Corcorran et al. 6,390,654 B1 5/2002 Diaz et al. 6,435,697 B1 8/2002 Simmons et al. 6,454,431 B1 9/2002 Grossman et al. 6,530,674 B2 3/2003 Grierson et al. 6,536,924 B2 3/2003 Segretto 6,568,830 B2 5/2003 Yaphe et al. 6,652,118 B2 11/2003 Shemitz et al. 6,659,625 B2 12/2003 Hanasaki 6,733,154 B1 5/2004 Dahlen 6,769,784 B2 8/2004 Yaphe et al.
(56)	<b>References Cited</b>				
	U.S. PATENT DOCUMENTS				
	2,344,935 A 3/1944 Whittaker 2,465,141 A 3/1949 Wakefield 2,474,308 A 6/1949 Franck et al. 2,535,840 A 12/1950 Coyle et al. 2,643,328 A 6/1953 Elmendorf 2,988,633 A 6/1961 Rosenfield 3,027,451 A 3/1962 Thomsen 3,118,620 A 1/1964 Bucek 3,120,929 A 2/1964 Henning 3,159,352 A 12/1964 Wakefield et al. 3,299,264 A 1/1967 Lipscomb 3,319,059 A 5/1967 Ogden 3,375,322 A 3/1968 Serio et al. 3,428,799 A 2/1969 Bassani 3,928,757 A 12/1975 Nelson 4,025,780 A 5/1977 Krase et al. D246,330 S 11/1977 Krase et al. 4,092,562 A 5/1978 Campbell 4,096,379 A 6/1978 Taylor 4,138,716 A 2/1979 Muhlethaler et al. 4,323,954 A 4/1982 Florence et al. 4,338,653 A 7/1982 Marrero 4,413,311 A 11/1983 Orenstein 4,420,798 A 12/1983 Herst et al. 4,464,707 A 8/1984 Forrest 4,574,338 A 3/1986 Takasaki et al. 4,633,377 A 12/1986 Mackiewicz				
		OTHER PUBLICATIONS			
		Undated H.E. Williams "AI" fixture photos. Undated H.E. Williams "TL" fixture photos.			
		* cited by examiner			

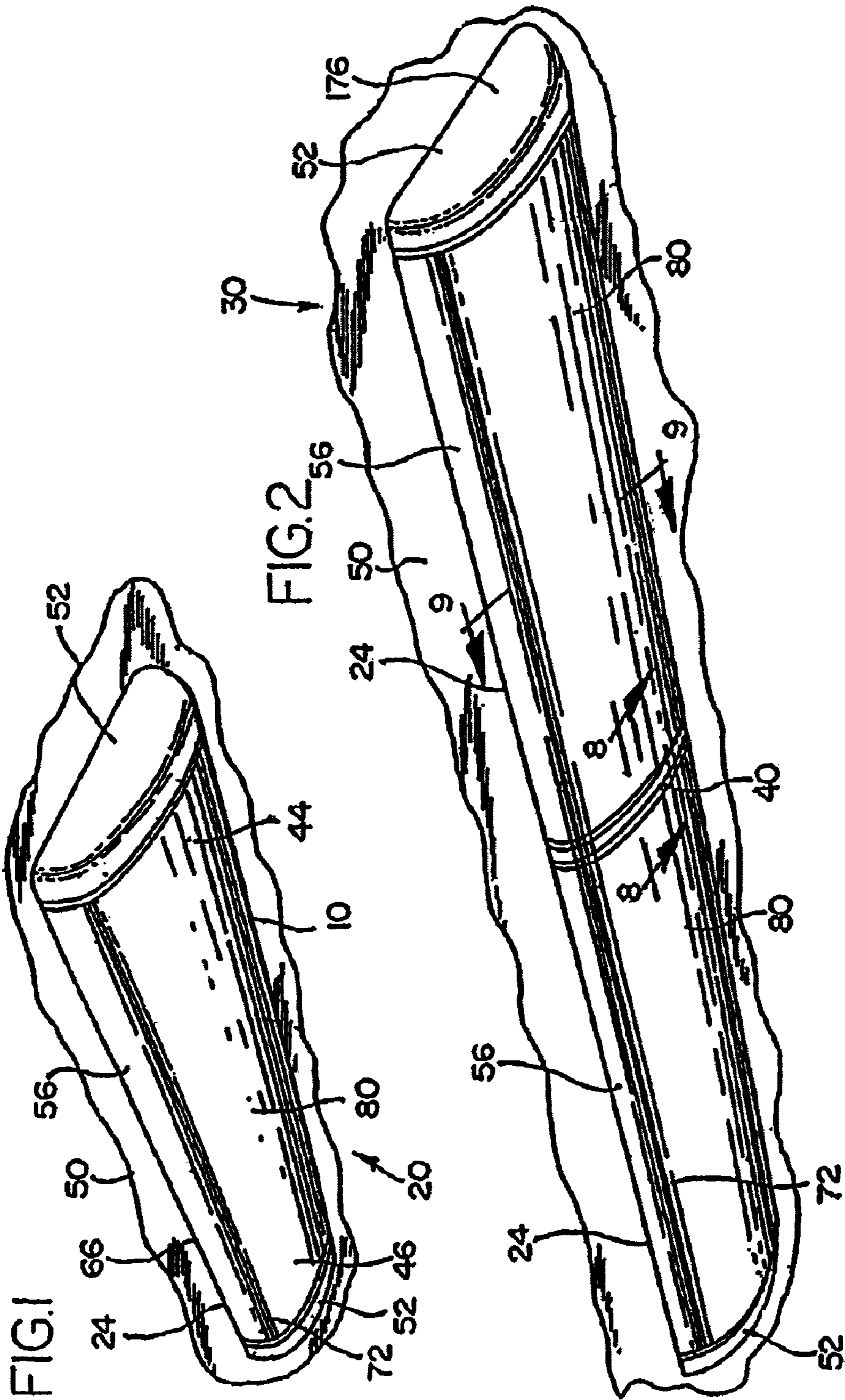
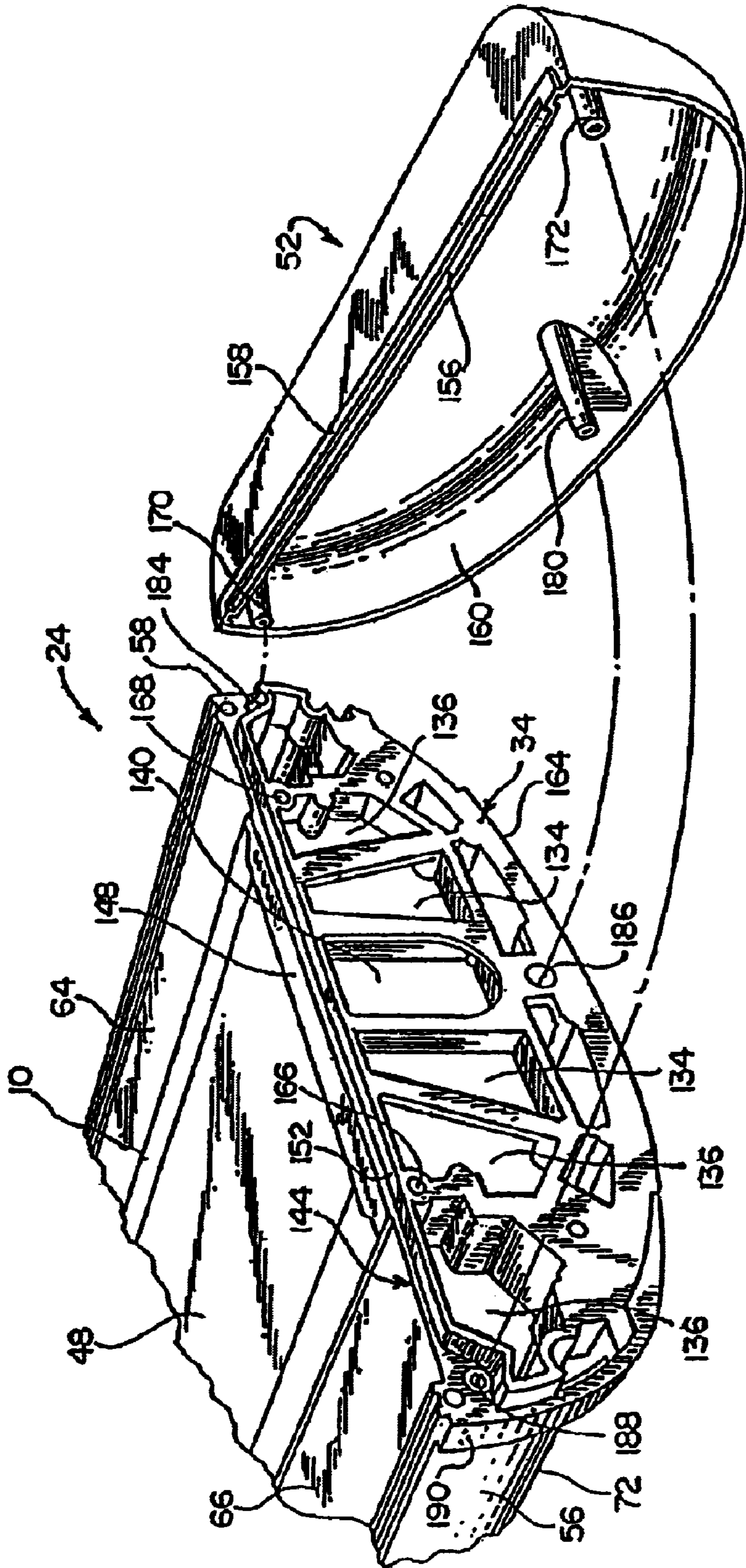

FIG. 3



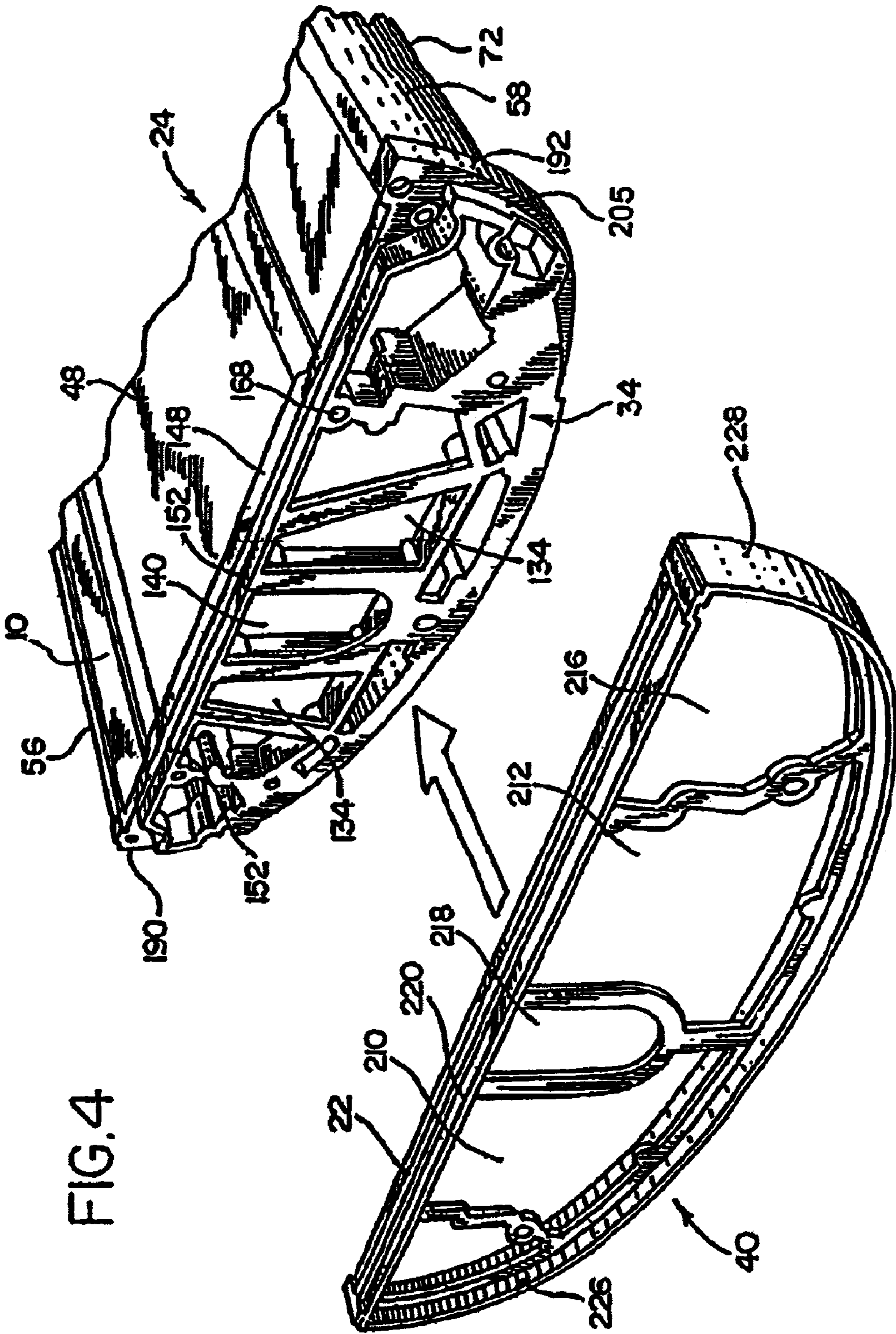

FIG. 4

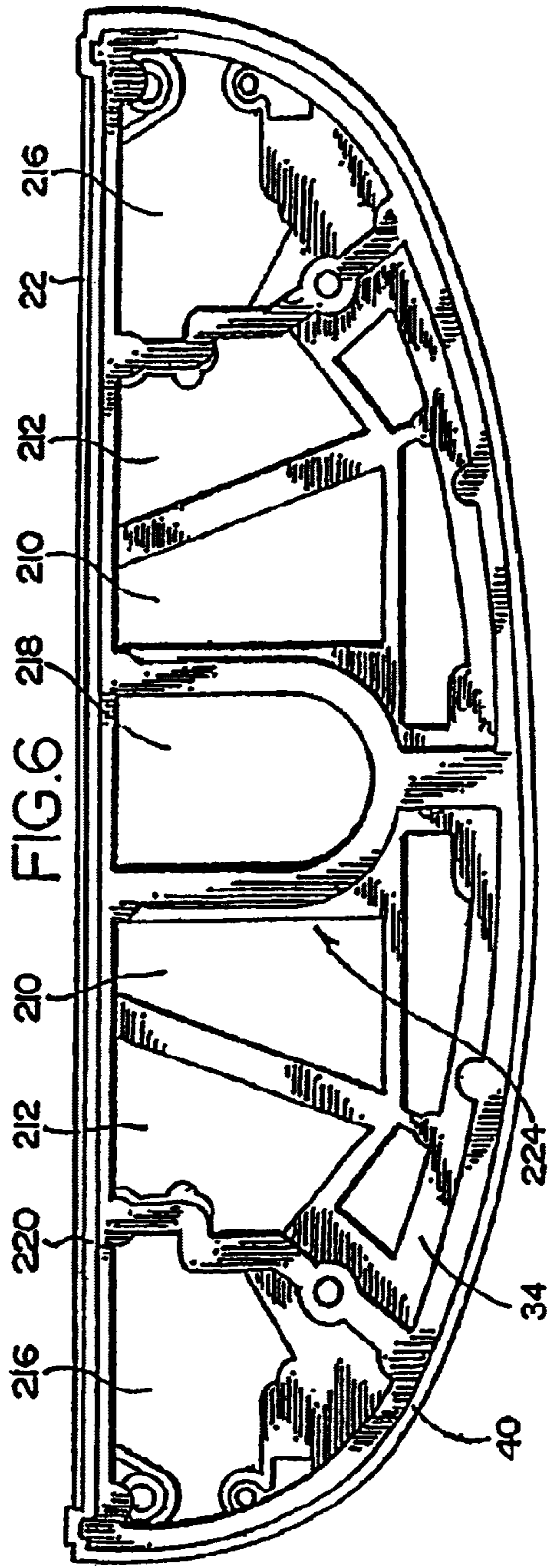
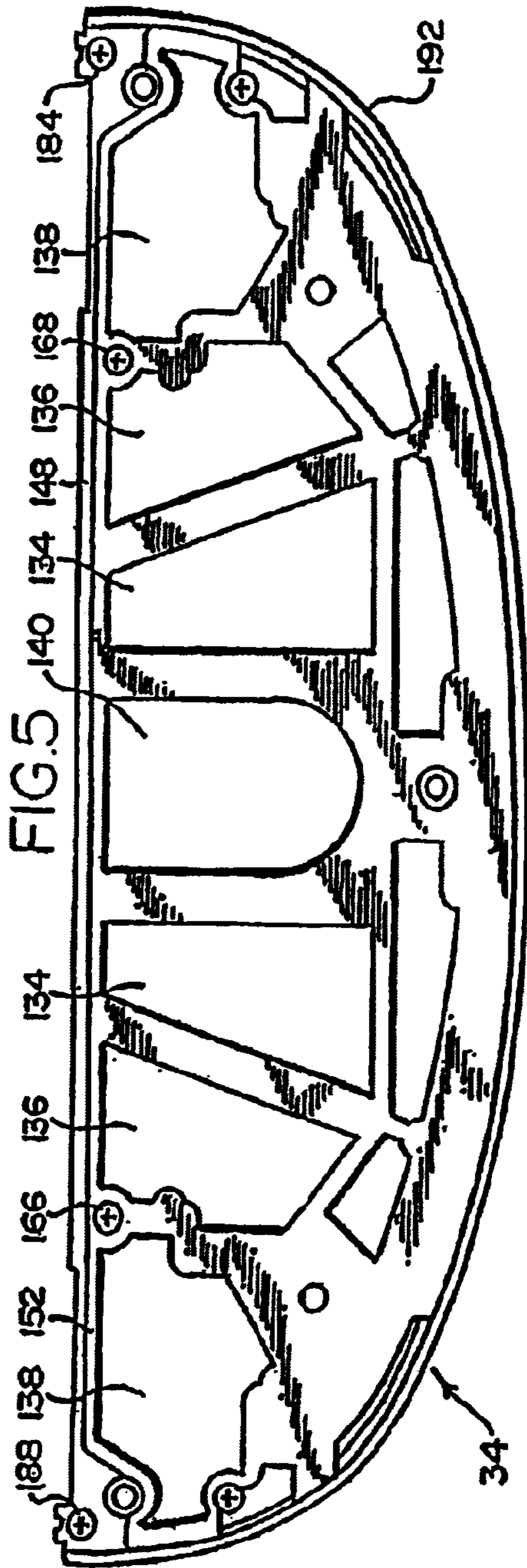

FIG. 7

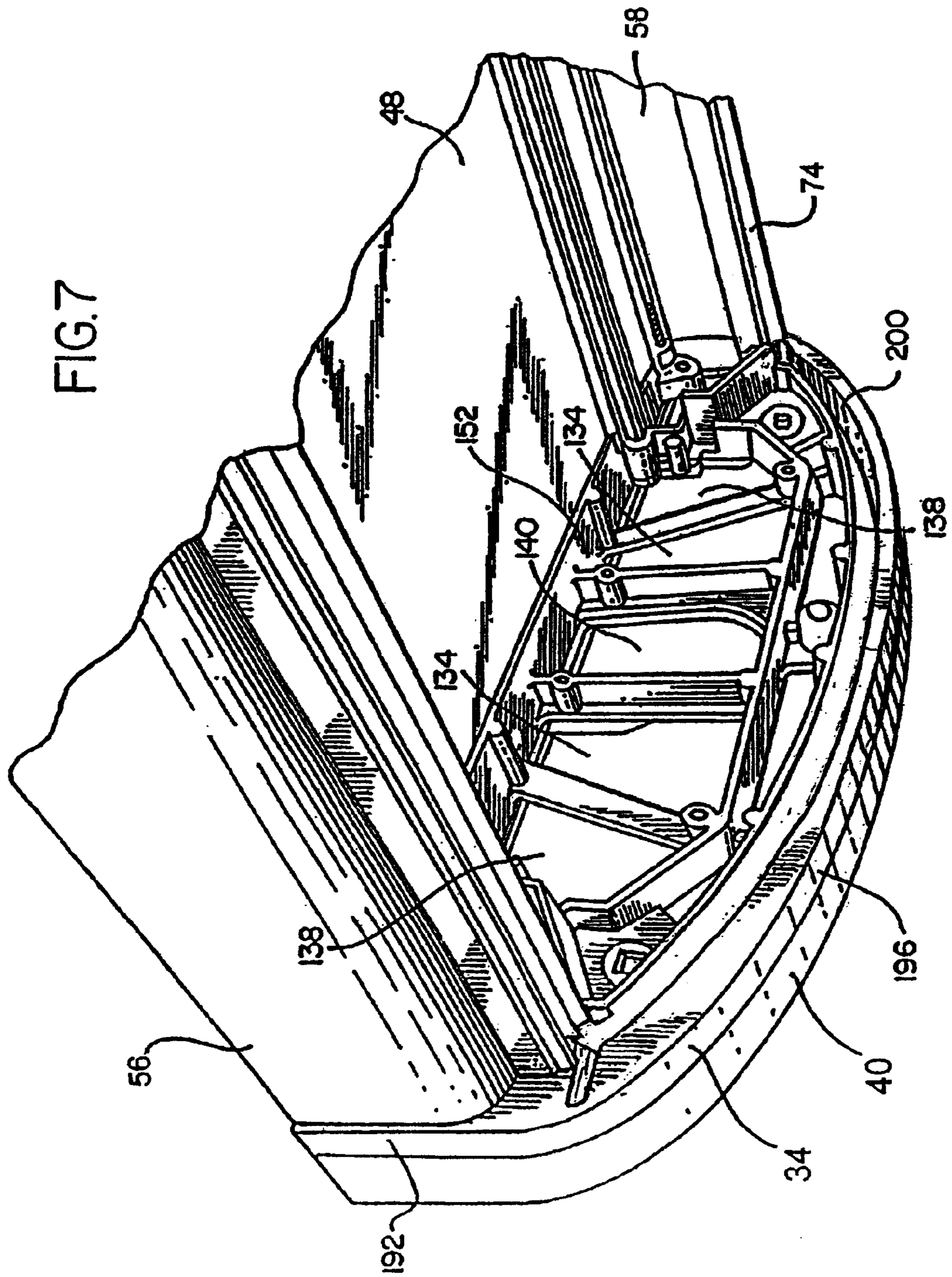
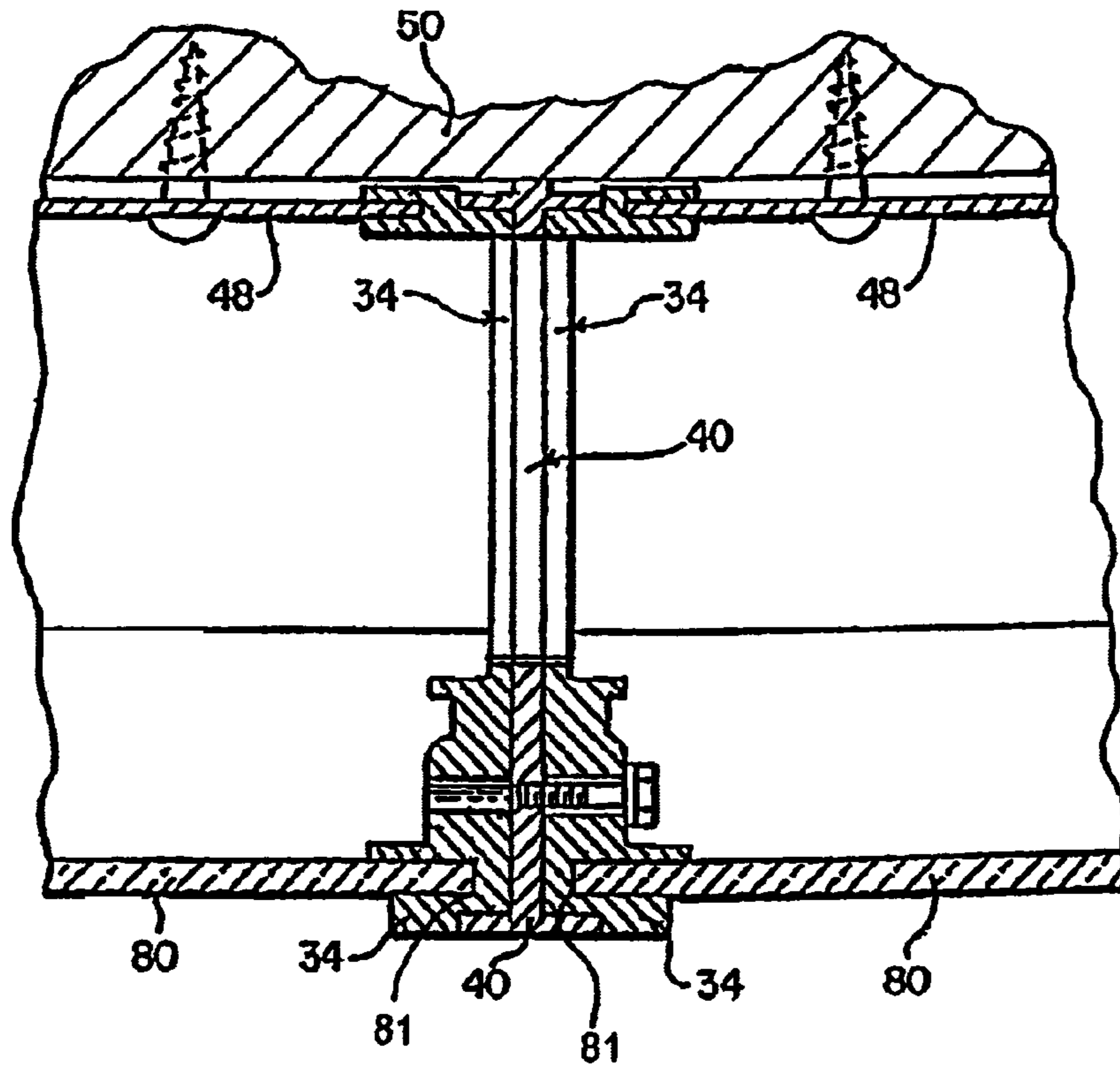

FIG.8





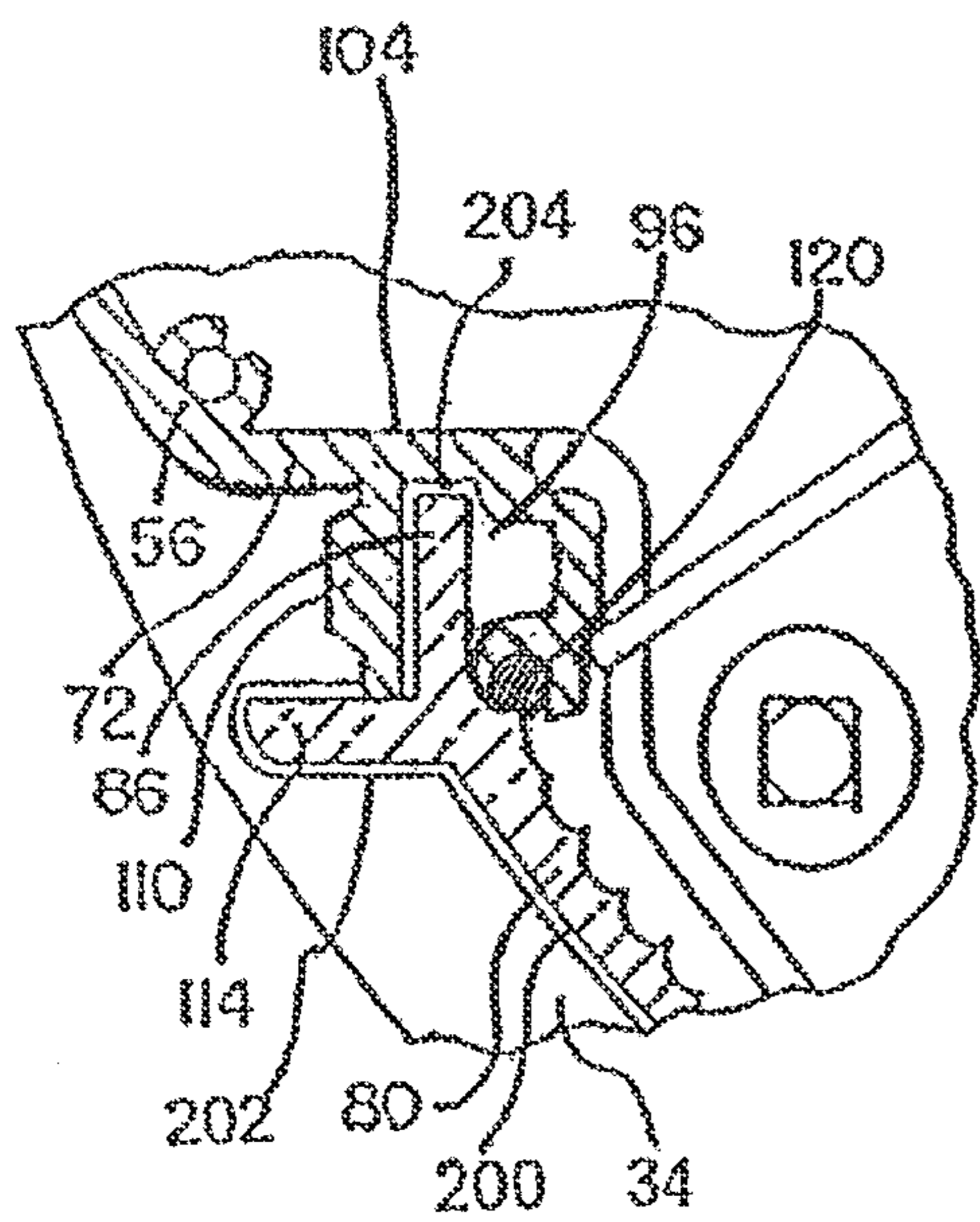

FIG. 9A  
Amended

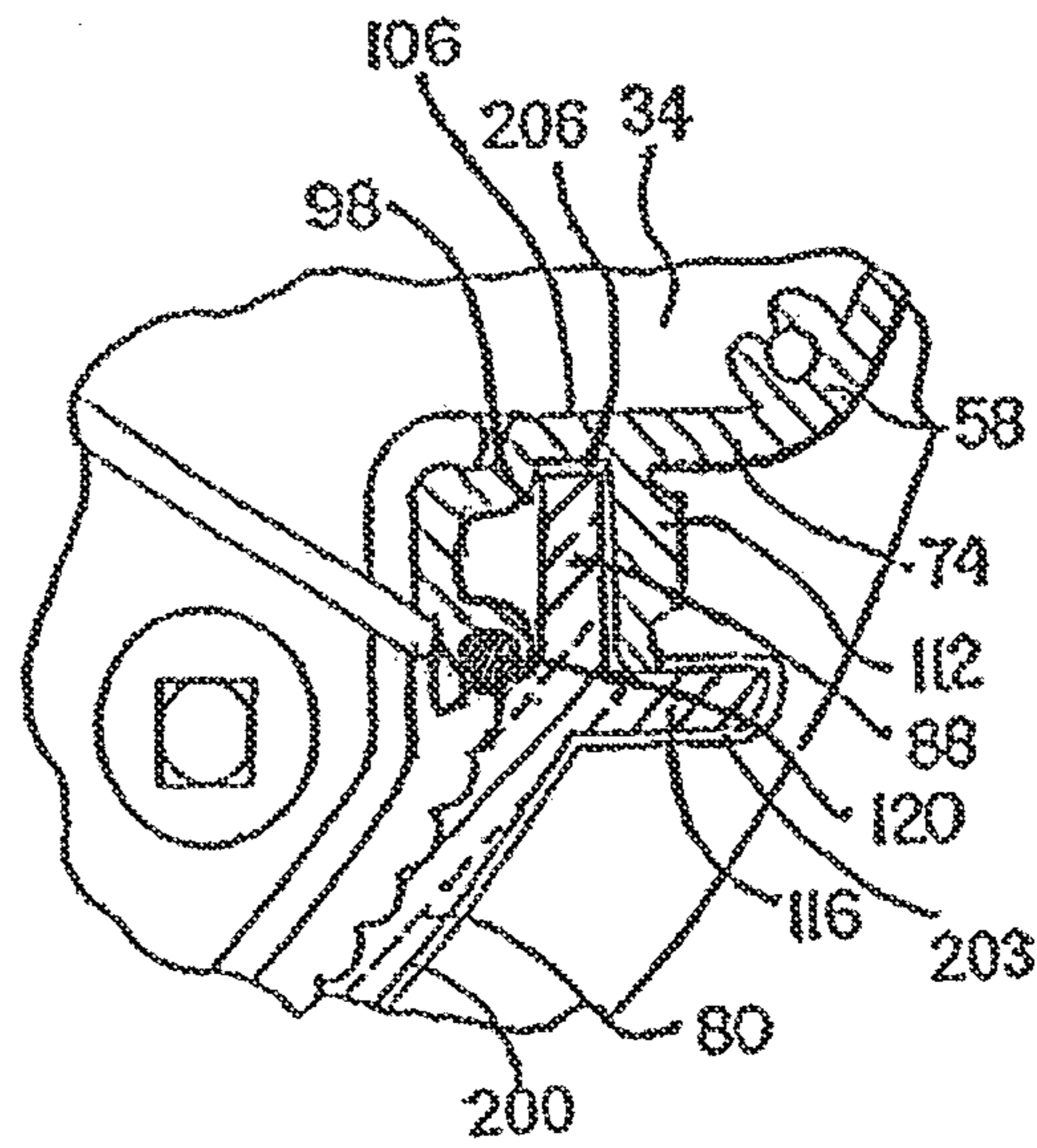

FIG. 9B  
Amended

FIG. 10

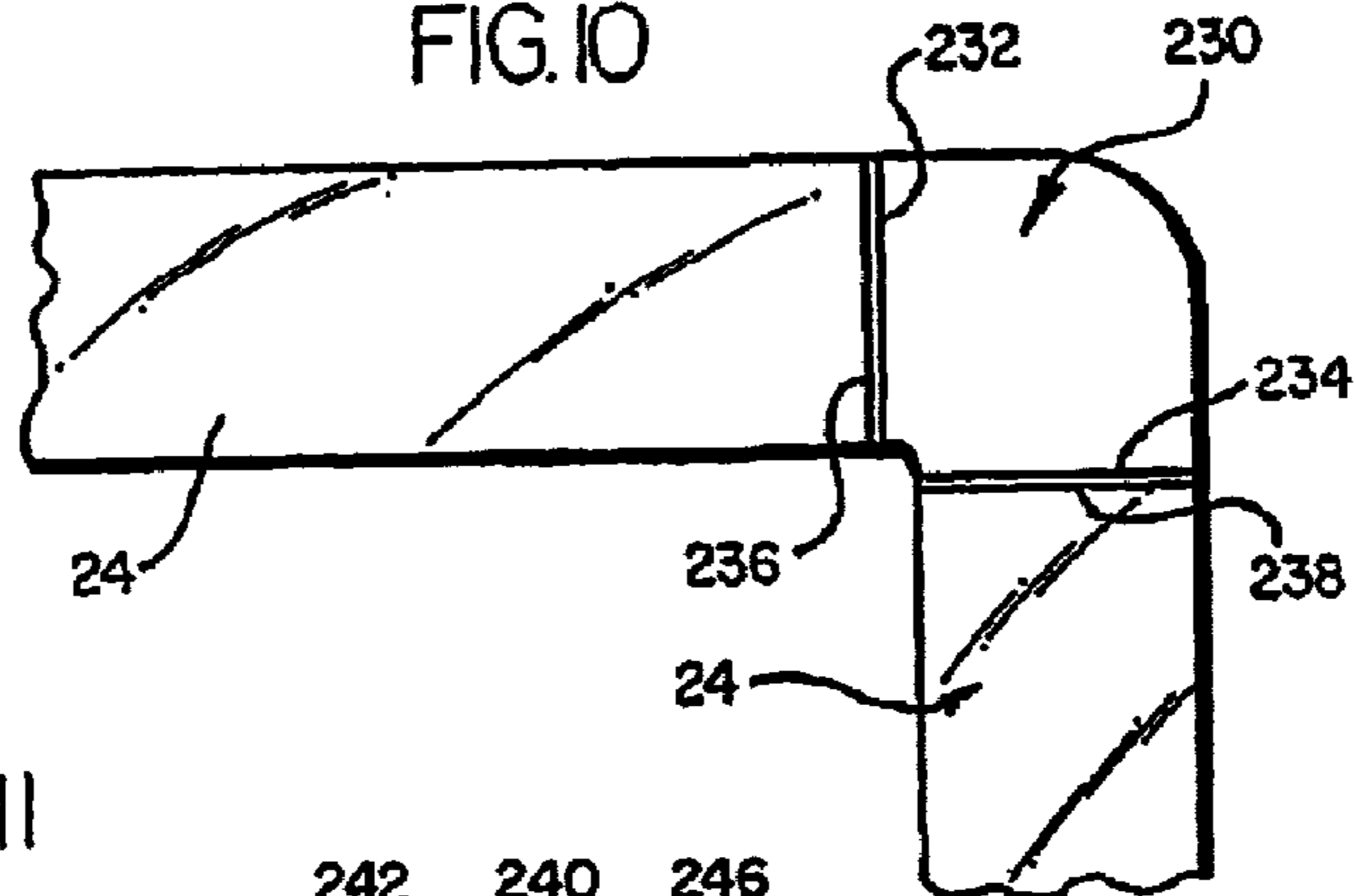

FIG. 11

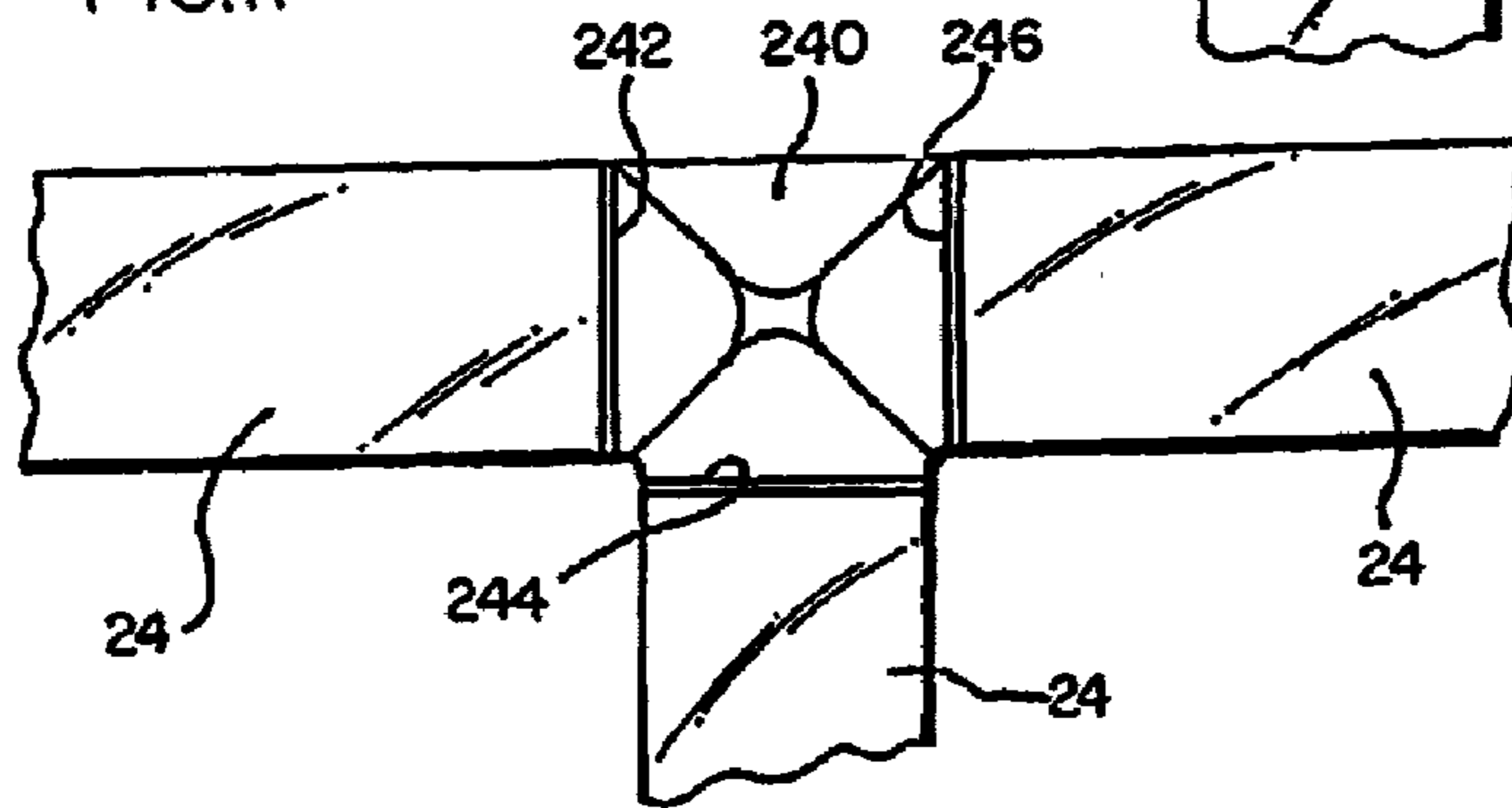
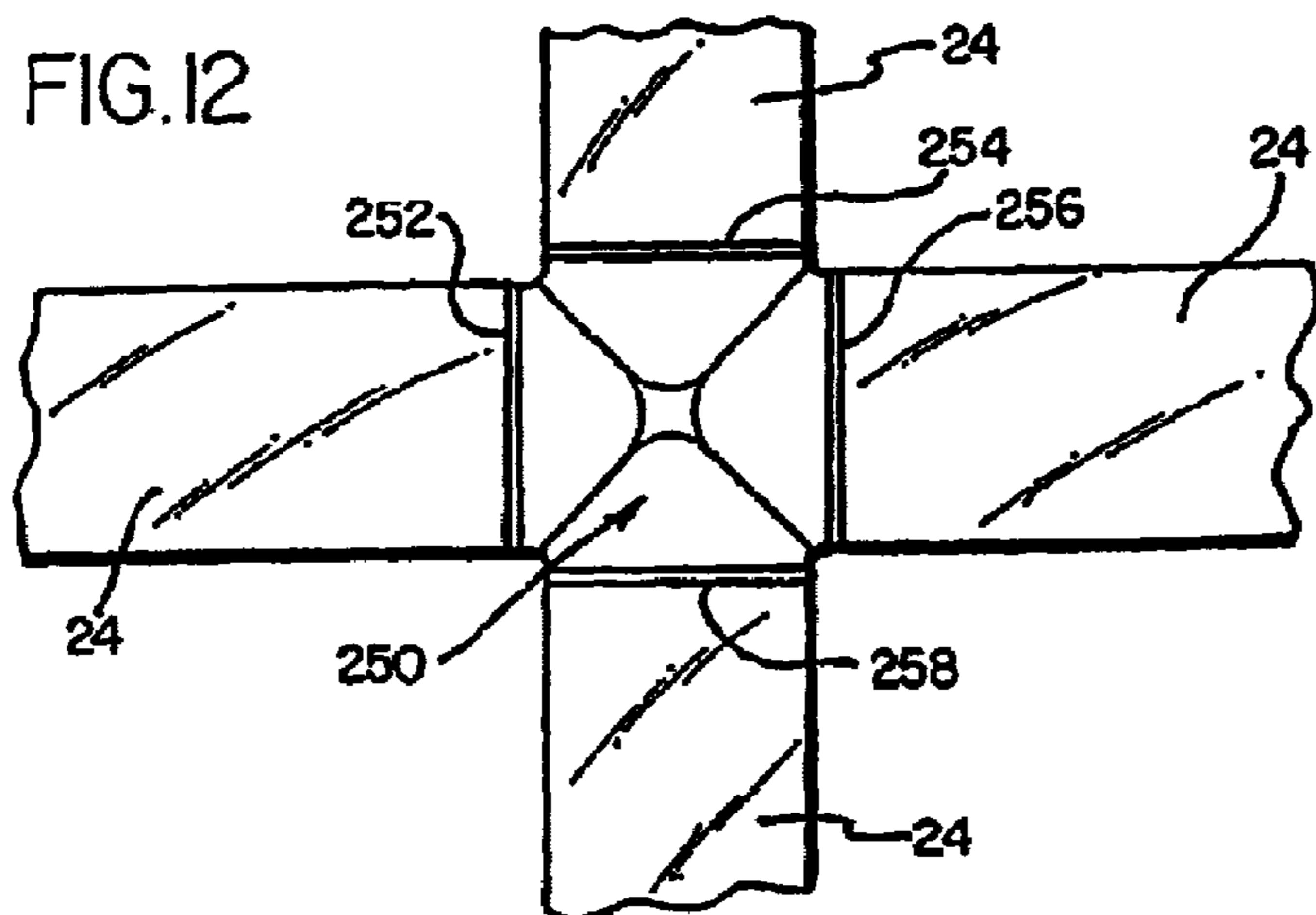

FIG. 12



## SELECTIVELY-EXTENDABLE MODULAR LIGHTING FIXTURE AND METHOD

**Matter enclosed in heavy brackets [ ] appears in the original patent but forms no part of this reissue specification; matter printed in italics indicates the additions made by reissue; a claim printed with strikethrough indicates that the claim was canceled, disclaimed, or held invalid by a prior post-patent action or proceeding.**

### RELATED APPLICATIONS

The present application is a continuation of patent application Ser. No. 10/156,423, filed May 28, 2002, now abandoned.

### FIELD OF THE INVENTION

The invention relates generally to a lighting fixture and, more particularly, to a modular lighting fixture adaptable for being implemented in various shapes and configurations.

### BACKGROUND OF THE INVENTION

Many different types of lighting fixtures, including elongate fixtures for various applications and locations, are known in the art. Such fixtures have been installed for illuminating stores, offices, supermarkets, schools, hospitals, banks, and other interior and exterior areas. Appreciating the versatility of such lighting fixtures, including the many engineering designs and configurations, there remains a need for improving versatility and adaptability of a lighting fixture, in order to facilitate and enhance particular applications.

Traditional lighting fixtures are not readily adaptable for adjusting length and changing physical configuration. In particular, conventional structures and lighting methods are not adapted for selectively implementing fixtures having different shapes.

### OBJECTS OF THE INVENTION

It is an object of the invention to provide an improved system for implementing lighting fixtures overcoming some of the problems and shortcomings of the prior art, including those referred to above.

Another object of the invention is to provide a modular lighting system easily adaptable for creating different shapes and configurations in linear lighting applications.

Another object of the invention is to provide a lighting system that provides one or more isolated raceways for other distribution applications, for example low voltage wiring, fiber optics, and others.

Still another object of the invention is to provide a system for sealingly connecting linear lighting modules to one another.

Yet another object of the invention is to provide a modular lighting system that allows a designer to implement linear lighting using any number of modules having selectable lengths.

How these and other objects are accomplished will become apparent from the following descriptions and drawing figures.

### SUMMARY OF THE INVENTION

According to an aspect of the invention, a modular lighting fixture includes first and second elongate housings each hav-

ing ends *and sidewalls*, first and second pairs of *unitary* endplates respectively mated with the ends of the first and second elongate housings, the endplates each having a peripheral rim, and a bridge adapted for joining one of the endplates of the first elongate housing with one of the endplates of the second elongate housing by sealing cooperation with the respective peripheral rims thereof.

According to another aspect of the invention, a modular lighting fixture includes first and second elongate linear housings each having ends *and sidewalls*, and a bridge adapted for sealingly connecting one of the ends of the first elongate housing to one of the ends of the second elongate linear housing, and for angularly disposing the second elongate linear housing.

According to another aspect of the invention, a modular lighting fixture includes a first elongate housing having ends *and sidewalls*, [an] *unitary* endplate adapted for sealing connection to an end of the first elongate housing, and a bridge for sealingly connecting the endplate to at least one additional structure, the bridge being one of an L, T, +, and X type.

According to another aspect of the invention, a modular lighting fixture includes first and second elongate housings each having ends *and sidewalls*, and a bridge structured for sealing connection of the first and second elongate housings to one another at respective ones of their ends; wherein the first and second elongate housings, when so connected, are non-collinear.

According to another aspect of the invention, a modular lighting fixture includes an elongate housing having lengthwise ends *and sidewalls*, and a pair of *unitary* endplates adapted for sealing attachment to either lengthwise end of the housing, each of the endplates having respective perimeter surfaces adapted for attachment to any one of a bridge adapted for angularly-directable extension of the housing, a bridge adapted for linear extension of the housing, and an endcap.

According to another aspect of the invention, a modular lighting fixture includes an elongate housing having two ends *and sidewalls*, and at least one *unitary* endplate engageable with one of the ends of the elongate housing, where, when the endplate is engaged with the elongate housing, at least two isolated raceways extend through the elongate housing and the endplate.

According to another aspect of the invention, a modular lighting fixture includes first and second elongate housings each having ends *and sidewalls*, two *unitary* endplates, each having two non-symmetrical end walls, disposed between the first and second elongate housings, an elongate lens attached to the first elongate housing, and a gasket disposed between the lens and the first elongate housing for providing fluid-impervious sealing between the lens and the first elongate housing.

According to another aspect of the invention, a modular lighting fixture includes a lighting fixture module having ends *and sidewalls*, and [an] *unitary* endplate affixed at each of the ends of the lighting fixture module, the endplate including an arcuate, inwardly-directed groove adapted for sealingly receiving an end edge portion of a lens.

According to another aspect of the invention, a modular lighting fixture includes an elongate lighting fixture housing having ends *and sidewalls*, a pair of *unitary* endplates respectively affixed at each of the ends of the lighting fixture housing, and an elongate lens adapted for mating attachment to the lighting fixture housing and having flanges along elongate sides thereof that overlie the lighting fixture housing.

According to another aspect of the invention, a modular lighting fixture includes a lens having a flange extending symmetrically along each of two longitudinal edges of the lens, and a linear-type lighting fixture housing having slot-like grooves extending along sidewalls of the housing, the grooves being adapted for receiving respective ones of the flanges therein, where attachment of the flanges in the grooves effects fluid-impervious sealing between the lens and the housing.

According to another aspect of the invention, a method of modular lighting fixturing includes providing an elongate first housing having ends *and* *sidewalls*, and providing a pair of *unitary* endplates with respective perimeter surfaces adapted for mating attachment to either end of the first housing, each of the endplates being attachable to any of an angularly-disposing bridge, a ring, and an endcap, where the bridge defines a structure adapted for angularly-directable extension of the first housing, and where the ring defines a structure adapted for linear extension of the first housing.

According to another aspect of the invention, a method of lighting includes providing a fluid-impervious lighting fixture adapted for being installed as any of an individual linear housing section, a continuous lighting fixture made up of individual linear housing sections, and a geometric linear lighting fixture made up of individual linear housing sections.

According to another aspect of the invention, a method includes providing a selectable number of linear lighting modules each adapted for being joined at an end thereof to an end of another of the linear lighting modules, each of the linear lighting modules being of a selectable length, and joining the selected number of linear lighting modules together to form a lighting fixture having two isolated raceways therein.

According to another aspect of the invention, a method of providing a lighting fixture includes providing first and second housing sections each having opposite ends *and* *sidewalls*, mounting *[an] a unitary* endplate to the opposite ends of each of the first and second housings, and sealingly joining together one of the mounted endplates for each of the first and second housing sections, thereby sealingly connecting the first and second housing sections to one another.

As a result of implementing certain aspects of the invention, lighting fixtures may be characterized as providing “[selectably extendable] *selectably-extendable* and angularly-directable linear lighting.” For example, by joining a number of modules, sections, or housing components to one another at end portions or segments thereof, a lineal array of selectable length or lineal expanse may be provided as required or desired. Alternatively, the fixture may consist of two linear arrays connected at ends thereof to define an angle, for example a 90 degree juncture or corner. In another example, lineal sectors or sections may be oriented with respect to one another to provide various different geometric configurations or shapes. Accordingly, a large variety of lighting design choices may be implemented efficiently. In addition, a structure according to the invention also provides fluid-impervious sealing.

Other and further objects, features and advantages of the invention will become apparent from the following further description considered with the drawing figures.

The foregoing summary does not limit the invention, which is instead defined by the attached claims.

#### BRIEF DESCRIPTION OF THE DRAWING FIGURES

FIG. 1 is a perspective view of a luminaire-type linear lighting fixture module having an endcap, according to an exemplary embodiment of the invention.

FIG. 2 shows two modular lighting fixture sections joined endwise to one another through an interposed coupler ring, according to an exemplary embodiment of the invention.

FIG. 3 is a fragmentary perspective view of a body section of a lighting fixture with *[an] a unitary* endplate affixed to the body section of the lighting fixture for attachment to an endcap, according to an exemplary embodiment of the invention.

FIG. 4 is a partially-exploded fragmentary perspective view showing an end of a body section of a lighting fixture module with *[an] a unitary* endplate secured in place for attachment to a ring-type coupling bridge, according to an exemplary embodiment of the invention.

FIG. 5 is an elevational view of *[an] a unitary* endplate for mounting on an end of the body of a housing section of a lighting fixture module, according to an exemplary embodiment of the invention.

FIG. 6 is an elevational view of a ring-type coupling bridge secured to the *unitary* endplate of FIG. 5, according to an exemplary embodiment of the invention.

FIG. 7 is a fragmentary upward perspective view, with parts omitted for clarity, showing a housing section having *[an] a unitary* endplate with a coupler fastened thereto, according to an exemplary embodiment of the invention.

FIG. 8 is a cross-sectional view taken substantially along the line 8-8 of FIG. 2, and illustrating a manner of securing one housing section or lighting fixture module to another, according to an exemplary embodiment of the invention.

FIGS. 9A and 9B are fragmentary, cross-sectional views taken along the line 9-9 of FIG. 2, with parts omitted for clarity, according to an exemplary embodiment of the invention.

FIG. 10 is a schematic plan view of two modular sections joined to one another at right angles by means of an “L” type connecting adapter to form an L-node or corner node assembly, according to an exemplary embodiment of the invention.

FIG. 11 is a schematic plan view showing three lighting fixture modules connected to a joinder adapter configured as a “T” node, according to an exemplary embodiment of the invention.

FIG. 12 is a schematic plan view of four lighting fixture modules joined to a rectangular, four-place coupler to form a “+” node type lighting fixture assembly in which the four modules arms extend at 90 degrees with respect to adjacent modules, according to an exemplary embodiment of the invention.

#### DETAILED DESCRIPTION OF PREFERRED EMBODIMENTS

FIG. 1 is a perspective view of a lighting fixture module 24 that may be configured in any of several different forms, in this case being configured as a single module fixture 20 by adding endcaps 52. Module 24 may also be *[referred-to] referred to* herein as “housing section 24” that includes a body section 10 and a pair of *unitary* endplates 34. Module 24 may also include a lens 80.

FIG. 2 shows a dual-module lighting fixture 30 having two housing sections 24. The two housing sections 24 of fixture 30 are secured end-to-end to one another at respective facing endplates 34 thereof (e.g., FIGS. 3-5, 7, 8), by a coupler 40 interposed between the respective *unitary* endplates 34.

Either fixture 20, 30 may be securely mounted at respective generally planar bases 48 thereof to a ceiling or similar structure 50. Free ends of housing section 24 may be sealed at *unitary* endplates 34 thereof with fitted endcaps 52. Endcap 52 abuts and is securely mounted to endplate 34, as shown by way of example in FIG. 3. Each housing section 24 includes

opposed lineally-extending side walls **56, 58** extending [co-extensively] *coextensively* with base **48** at elongate upper edges **64** and **66** thereof.

Housing sidewalls **56, 58** of elongate modular lineal section **24** are formed of an extruded high-strength metal alloy, such as aluminum alloys, as a body portion **10** of each modular sections **24**. Sidewalls **56, 58** are formed at opposite elongate edge portions thereof with channel-like, downwardly-opening grooves **96, 98** that matingly receive therewithin the elongate free edge portions of lens **80**. A gasket (not shown) may also be used for sealing the elongate sides of lens **80** with elongate grooves **96, 98** of housing **24**. Lens **80** is preferably formed of a [high strength plastics] *high-strength plastic* composition.

Elongate, sheet-like, arcuate lens **80** extends generally along the bottom of housing section **24** and is secured at its lengthwise sides to [longitudinally extending] *longitudinally-extending* lower free edges **72, 74** of the opposed sidewalls **56** and **58** of housing section **24**. In one embodiment, lens **80** has upwardly-directed flanges **86, 88** (e.g., FIGS. **9A-9B**) that respectively seat within downwardly-opening elongate grooves or slots **204, 206** in *unitary* endplate **34** and in channels **96** and **98** formed in lower free elongate opposed edge zones **104** and **106** of housing sidewalls **56** and **58**.

Each *unitary* endplate **34** is formed at an inner face thereof with an arcuate, [inwardly opening] *inwardly-opening* slot or groove **200** extending along a bounding peripheral edge zone thereof for slideably receiving, to seat in sealing engagement therewith, an [end edge] *end-edge* portion of lens **80**, thereby providing sealing engagement of lens **80** with groove **200**. The inner face of *unitary* endplate **34** is also formed for accepting therewithin, in mating and sealing engagement, the extruded housing **24**.

For example, downwardly-projecting strips **110, 112** respectively extend longitudinally along a lineal expanse of sidewalls **56, 58**. At their free [end edges] *end-edges*, strips **110, 112** respectively abut in sealing engagement with *unitary* endplate **34**. Channel **200**, which opens outwardly, is contoured, configured and sized at its opposite lateral portions for receiving in close and sealing engagement therewithin the respective opposed edge portions **72** and **74** of the sidewalls **56** and **58**.

[As shown in FIGS. **9A-B**, a die cut gasket **120** may be interposed to sealingly engage the strips **110, 112** and lens **80**.] As shown in FIGS. **9A-9B**, channel **200** of *unitary* endplate **34** may be aligned with corresponding channels **96, 98** of housing **24**.

[Endplates] *Unitary endplates 34* are structured in a skeletal, bridge-like manner for mating engagement and positive attachment to each end of housing section **24**, thereby providing through-frame openings. Skeletal adapter ring **40** is attachable to either *unitary* endplate **34** for facilitating attachment of an additional housing section or module **24** to provide a lighting fixture comprised of two or more modular housing sections **24**.

[Endplates] *Unitary endplates 34* may be formed as high-strength castings having a metal composition, preferably being composed of a lightweight material such as an aluminum alloy. [Endplates] *Unitary endplates 34* have an inner face perimeter contour corresponding to a perimeter contour of the combined [end-wise] *endwise* edge of the housing section **24** including an attached lens **80**. The outer face perimeter contour of *unitary* endplate **34** corresponds to a perimeter contour of the ring **40**, endcap **52**, or other bridge being attached to endplate **34**. For example, *unitary* endplate **34** may have a perimeter shoulder **205** for sealingly engaging

either an inner rim **226** of coupler ring **40** or an inner edge **160** of endcap **52** to be secured thereon.

Ring **40** has a circumscribing top wall that is [integrally formed] *integrally-formed* with [laterally extending] *laterally-extending* ring-like flanges **220** dimensioned and configured to overlies in sealing engagement therewith a mating **152** wall of *unitary* endplate **34** formed adjacent shoulder portion **205**.

As shown by way of example in FIGS. **3** and **4**, [an] *a* *unitary* endplate **34** is securely engaged with body portion **10** at each end thereof, thereby forming a housing section **24**. [Endplate] *Unitary endplate 34* has a plate-like, skeletal body **142** having a plurality of [through openings] *through-openings* or passageways **134, 136, 138** and **140** formed therein. Such passageways **134, 136, 138, 140** provide wire routing structures that facilitate passage therethrough of electrical wires, illuminating sources, other electrical components, and related structures such as various cabling, adapters, etc. As described in more detail below, passageways **134, 136, 138, 140** may each be parts of individual isolated raceways extending the entire length of module **24** by including enclosed passages within body portion **10**. [Endplate **34** has a top flange **148** which extends continuously along a top end edge of the base **48** for sealing engagement with housing section **24**.] *Unitary endplate 34 has a top flange 148 which extends continuously along a top end edge of the base 48 for sealing engagement with housing section 24.* [Integrally formed] *Integrally-formed* with and [co-extensive] *coextensive* with the top flange **148** and stepped downwardly with respect thereto is a second flange **152**.

[Endplate] *Unitary endplate 34* is formed with opposed upper side sectors **190, 192** and a continuing lower arcuate section **196** thereof. As shown in the interior view of FIG. **7**, the interior side of *unitary* endplate **34** has an uninterrupted channel **200**. Channel **200** is configured and sized for receiving in sealing engagement therewith the end portions **81** of lens **80**. Channel **200** of *unitary* endplate **34**, as shown by example in FIGS. **9A-9B**, has laterally-extending portions **202, 203** structured for respectively receiving outward-extending flanges **114, 116** of lens **80**. Similarly, vertically-oriented flange portions **86, 88** of lens **80** respectively fit into channels **204, 206** of *unitary* endplate **34**. [Die-cut gasket] *Gasket 120* may be formed in an appropriate manner for sealing of endplate **34**, for example by being interposed for sealingly engaging strips **110, 112** and lens **80**. Gaskets can include die-cut gaskets and the like. Lens **80** provides distribution of illuminating light emanating from the fixture, and is preferably composed of a high-impact, shock-resistant plastic composition, such as an acrylic plastic or a polycarbonate plastic. As shown in the example of FIGS. **9A-9B**, lens **80** is formed to engage channel **200**.

Endcap **52** is integrally formed with a flange **156** projecting outwardly along a top, free edge **158** thereof. When endcap **52** is positioned in place to mate with and close the end of housing section **24**, the top flange **156** of endcap **52** is brought to overlies and to effect a sealing engagement with flange **152** of *unitary* endplate **34**. An arcuate lower flange **160** of endcap **52** engages and seals with a cooperating lower flange **164** of *unitary* endplate **34**. [Endplate] *Unitary endplate 34* is positively secured to the end of body portion **10** of housing section **24** with screws (not shown).

Endcap **52** is integrally formed with connector posts **170** and **172** projecting from the interior of the end wall **176** at opposed upper corners thereof. A third connector post **180**, also integrally formed with the endcap **52**, projects inwardly from the interior of the end wall **176** at a central lower area thereof. When endcap **52** is positioned in place, the free ends

of posts 170, 172 and 180 penetrate to seat, respectively, in cooperating outwardly-presented bores 184, 188 and 186 formed in *unitary* endplate 34.

Housing sections 24, which may be of any practical selectable lengths, each have [an] *a unitary* endplate 34 at lengthwise ends thereof. Outer faces of *unitary* endplates 34 of two [linearly adjacent] *linearly-adjacent* housing sections 24 are brought matingly to engage an interposed coupling ring 40, thus to effect a sealed joiner of the two adjacent housing modules 24. For example, lighting fixture 20 has a single module 24 of selectable length; alternatively, any number of modular sections 24 may be joined to one another endwise as a lineal or in-line array, such as two-module lighting fixture 30 shown in FIG. 2 with coupler ring 40 being used to lineally connect modules 24 as shown in FIG. 4. Such is effective to provide a lineal lighting fixture of any desired or required expanse.

In the example where two or more housing sections 24 joined endwise as a continuous uninterrupted physical structure (e.g., FIG. 2) with a coupler ring 40 (e.g., FIG. 4), coupler ring 40 has generally a contour and form compatible with *unitary* endplate 34 and is preferably formed as a metal casting of an aluminum alloy or similar material. Coupler ring 40 is formed with a plurality of [through openings] *through-openings* 210, 212, 216 and 218. Such openings essentially correspond with openings formed in the *unitary* endplate 34 and are in [through registry] *through-registry* therewith when endplate 34 and coupler ring 40 are joined together in an assembled lighting fixture having a plurality of body sectors or modules 24.

Coupler ring 40 has a transversely-extending [generally planar] *generally-planar* top surface 220 and an arcuate bottom surface 228, the flange-like top wall 220 extending laterally of the body 224 at each of opposed sides thereof effectively to provide two opposed flanges straddling a center portion 22. Flange-like top wall 220 may be engaged with a [downwardly displaced] *downwardly-displaced* or stepped flange 152 of [an] *a unitary* endplate 34. [Endplate] *Unitary endplate* 34 is secured to body portion 10 of housing module 24 as previously described. A second lighting fixture module 24 may be fastened, at its secured *unitary* endplate 34 at the opposite, [co-extensive] *coextensive* second part of the flange 220 thus to effect a coupling of two housing sections 24 to one another endwise. In the manner described, it becomes simple and quick to produce a row-mount lighting fixture having a selectable number of separate housing sections each being of a selectable length. Thus, one may readily assemble a lighting fixture of any final overall length, as may be required or desired.

A lighting fixture may include either a single module 24 of selectable length or, alternatively, a plurality of modular sections, sectors, or housing sections 24. Such may be joined to one another endwise as a lineal or in-line array. The method is readily effective to provide a lineal lighting fixture of any desired or required expanse. Many other embodiments of the invention are possible. Modular sections 24 maybe coupled at joined ends thereof to extend normally to one another to define a right-angle corner. Others may be connected by means of a T-shaped coupler to form a "T". Still other modular sections, of selectable lengths, may be connected to form an "X" or a cross "+". Since each module 24 has *unitary* endplates 34 attached thereto, the chosen coupler is adapted to be secured to the respective *unitary* endplate 34.

Referring now to FIGS. 10, 11, and 12, lighting fixture embodiments are not limited to extending along a straight line, but may include other geometric configurations. For example, referring first to FIG. 10, there is shown a fragmen-

tary view of a lighting fixture having two modular sections 24 oriented to extend orthogonally with respect to one another. A generally rectangular connector 230 with an "L" shape has a pair of adjacent sides 232 and 234 to which ends 236 and 238 of the modular sections 24 are sealingly joined to form a corner assembly. The resulting fixture having an L shape is suited, for example, for accommodating sharp bends, and for corner installations. Various combinations may be implemented. For example, a use of four such L connectors 230 and four modular sections 24 may be assembled to provide a lighting fixture in the physical configuration of a closed rectangular "loop."

In another example of a non-linear embodiment, FIG. 11 shows a generally rectangular connector 240 having three sides 242, 244, 246 to which three corresponding separate modular sections 24 of the fixture are connected. The assembled fixture of FIG. 11 thus assumes a "T" configuration.

Yet another embodiment of the invention is depicted in FIG. 12. As shown, a four-sided rectangular connector 250 has four sides to which a corresponding end 252, 254, 256, 258 of a separate module or fixture section 24 is joined. There results a fixture having a cross "+" type configuration. Further, an "X" type configuration of a lighting fixture may be formed. It will be appreciated that, through the selection and use of appropriate connectors, various open and closed loop lighting fixtures may be provided.

Individual and joined bridges and/or housing sections 24 of a given lighting fixture establish therein, and along an entire expanse thereof, uninterrupted passageways. Such passageways may include "raceways" for accommodating wires, cables and the like. Such may be effectively isolated from ballasts and lamp wires. By providing physical barriers establishing and effectively separating a number of isolated raceways, for example, a passageway for the ballast power feed wires of a fluorescent lighting fixture does not interfere with the isolated raceways. Such a physical structural arrangement is highly desirable and is considered novel. The structural arrangement and configuration of lighting fixtures in accordance with the present invention may be utilized for effecting important physical separation of high voltage and low voltage wiring. The utility and versatility of such lighting fixtures are thereby enhanced. The structures of *unitary* endplate 34 and coaxial coupler ring 40 are skeletal in construction with a plurality of [through openings] *through-openings* or passageways or runs. Such may provide coupling elements of extended raceways between modules 24.

For example, items that may be safely housed in an isolated raceway such as one contained in fixtures according to the present invention, include 24-volt alarm circuitry, such as wiring for a fire alarm, fiber optic network cables, thermostat wires, telephone wires, etc. Such capabilities provided by the present invention are believed to be capabilities unique in lighting fixtures of a general [linear type] *linear-type*.

It may be especially advantageous and convenient to fabricate all of the modular body sections 24 of a lighting fixture to be a same length. However, such arbitrary uniformity is in no sense a requirement. Conveniently, for example, individual luminaires may be formed using sections 24 nominally 8"×24", 8"×48", 8"×60", etc. Other embodiments may be formed using sections 24 nominally 12"×24", 12"×48", 12"×60", etc.

As a result of the present invention, an extendable modular lighting fixture may be structured to provide interconnections having physical and electrical continuity. Such a structure is effectively tolerant of and resistant to physical abuse as well as to environmental hazards. The lighting fixture may include

a linear illumination source and a lighting track in the housing, the lighting track including a passageway structured for accommodating electrical conductors for connecting the lighting fixture to an independent electrical power supply. Wire-ways may be formed within the lighting fixture for accommodating conductive wires. The lighting fixture may further include a gasket seated and secured in the housing along an expanse thereof and in sealing engagement for sealing the housing against invasion by objectionable ambient and foreign substances. A lighting fixture may further include a gasket disposed between the body of the fixture and its lens for establishing a fluid-impervious seal between the body of the fixture and the lens. Various structures may be used to establish a fluid-impervious seal between the body of the fixture and the lens.

A method of making and assembling a lighting fixture having any selectable length and finding utility in ceiling, wall and corner installations including suspended mounts may include utilizing modular components in selectable numbers, each component being of any desired length, the components being connectable to one another endwise as a sealed, operating assemblage constituting a lighting fixture. A method may include mounting [an] *a unitary* endplate 34 on the housing-like body section 24 coaxially therewith at each end thereof.

A method may include fabricating any of the various components, such as by casting. A method may include forming the *unitary* endplates 34 to define a parametric contour corresponding to a parametric contour of each [end edge] *end-edge* of housing section 24, including a surmounting lens 80 of housing section 24. A method may include casting endplates 34 to define a lattice-like wall configuration including a plurality of dividers and [through openings] *through-openings* demarking passageways in end walls of housing section 24. A method may include forming [an] *a unitary* endplate 34, at an inwardly-presented limit thereof, with a coupling structure for engaging end structures of functionally-united, intercoupling and extending ends including extrusion and lens 80. A method may include forming a side or face of *unitary* endplate 34, opposite the side of lens 80, with a circumscribing perimeter shoulder for [selectively sealingly] *selectively-sealingly* engaging either one of a coupler ring to be sleevedly attached thereto, or an endcap of another module 24.

Further, a method may include forming a casting as a bilateral coupler to be secured to a free end of [an] *a unitary* endplate 34 mounted on an end of a body section 24. Such a casting may be formed as a ring 40 including at a circumscribing top wall thereof integrally-formed, [laterally extending] *laterally-extending* ring-like flanges each being dimensioned and configured to overlie in sealing engagement therewith a mating top wall of [an] *a unitary* endplate 34. Such may provide a positive endwise joinder of two housing sections 24 to one another in a lineal array. A method may include forming an endcap 52 of a *unitary* one-piece configuration having a base, an upstanding endwall, and a top, and defining an integrally-formed, uninterrupted, circumscribing free edge contoured to be congruently fittable over a corresponding circumscribing parametric shoulder of *a unitary* endplate 34 in sealing engagement therewith.

A method may include forming [plastics] *plastic* lens 80 to define along each extending edge thereof with an angled flange for overlying an edge of the coextensive extruded base of housing or body section 24. A method may include forming *unitary* endplate 34, at an inner face thereof, with an [outwardly opening] *outwardly-opening* slot or groove extending along a bounding coextensive edge zone thereof for accepting

therewithin, in mating and sealing engagement therewith, the extruded metallic base component of the housing and the [plastics] *plastic* lens thereof.

A method may include configuring *a unitary* endplate, at one of its faces, to define an end face contoured for mounting thereon and affixing thereto, selectively, either an endcap 52 for capping and closing housing 24 of the modular structure, or a ring 40 in the form of a band-like coupler. The method may include configuring such a coupler for sealingly mounting onto *a unitary* endplate 34 of housing 24 for joining the end of housing section 24 to [an] *unitary* endplate 34 of a housing body of a second modular housing section 24 of the lighting fixture so that the sections are sealingly joined to one another endwise.

A method may include forming an endcap 52 with an integral, circumambient, outwardly-projecting, flange-like edge portion configured to overlie, in sealing engagement therewith, a perimetric shoulder circumscribing an [outwardly presented] *outwardly-presented* face of [an] *a unitary* endplate 34 attached to housing 24.

While the principles of the invention have been described in connection with presently preferred embodiment of the present invention, it will be understood by those skilled in the art that many changes in construction and widely differing embodiments and applications of the invention will suggest themselves without departing from the scope of the present invention, as defined in the claims. The disclosures and the description herein are intended to be illustrative and are not in any sense limiting of the invention, defined in scope by the following claims.

What is claimed is:

1. A modular lighting fixture comprising:

first and second elongate housings each having *sidewalls and ends*;

first and second pairs of *unitary* endplates respectively mated with the ends of the first and second elongate housings, the endplates each having a peripheral rim; and

a bridge adapted for joining one of the endplates of the first elongate housing with one of the endplates of the second elongate housing by sealing cooperation with the respective peripheral rims thereof.

2. The modular lighting fixture of claim 1 wherein the bridge is one of an L, T, +, and X type.

3. The modular lighting fixture of claim 1 wherein:

the first and second elongate housings each include a first raceway for routing distribution media; and

the bridge includes a first wire pathway interconnecting the two first raceways.

4. The modular lighting fixture of claim 3 wherein the first and second elongate housings each include a second raceway and the bridge includes a second wire pathway interconnecting the two second raceways.

5. The modular lighting fixture of claim 4 wherein the first and second raceways are isolated from one another.

6. The modular lighting fixture of claim 1 wherein each of the endplates has a first side structured for attaching an additional structure and a second side structured for holding an arcuate lens, the second side having a face different from a face of the first side.

7. A modular lighting fixture comprising:

first and second elongate linear housings each having *sidewalls and ends with a raceway defined therein*; and

a bridge adapted for sealingly connecting one of the ends of the first elongate housing to one of the ends of the second elongate linear housing, and for [angularly disposing] *angularly-disposing* the second elongate linear housing.

## 11

8. The modular lighting fixture of claim 7 wherein the bridge is one of an L, T, and X type.

9. The modular lighting fixture of claim 7 wherein an isolated first raceway is defined within the first and second elongate housings and within the bridge.

10. The modular lighting fixture of claim 9 wherein an isolated second raceway is defined within the first and second elongate housings and within the bridge.

11. A modular lighting fixture comprising:  
a first elongate housing having *sidewalls and ends*;  
[an] a *unitary* endplate adapted for sealing connection to an end of the first elongate housing; and  
a bridge for sealingly connecting the endplate to at least one additional structure, the bridge being one of an L, T, +, and X type.

12. The modular lighting fixture of claim 11 wherein the at least one additional structure is a second elongate housing having *sidewalls and ends*.

13. The modular lighting fixture of claim 11 wherein the at least one additional structure is an endplate.

14. A modular lighting fixture comprising:  
first and second elongate housings each having *sidewalls and ends and a raceway defined therein*; and  
a bridge structured for sealing connection of the first and second elongate housings to one another at respective ones of their ends,

wherein the first and second elongate housings, when so connected, are non-colinear.

15. The modular lighting fixture of claim 14 wherein the bridge is one of an L, T, +, and X type.

16. The modular lighting fixture of claim 14 wherein the bridge includes a wire pathway.

17. The modular lighting fixture of claim 16 wherein the first and second elongate housings each include a raceway, and wherein the two raceways are connected to one another via the wire pathway of the bridge to form an isolated conduit within the lighting fixture.

18. The modular lighting fixture of claim 14 wherein the bridge includes a collar, and wherein the sealing structure for sealing connection of the two elongate housings to one another via the bridge includes snug engagement of peripheral portions of the respective ends of the housings with the collar of the bridge.

19. A modular [linear-type] lighting fixture comprising:  
an elongate housing having *sidewalls and lengthwise ends*; and

a pair of *unitary* endplates adapted for sealing attachment to either lengthwise end of the housing, each of the endplates having respective perimeter surfaces adapted for attachment to any one of a bridge adapted for angularly-directable extension of the housing, a bridge adapted for linear extension of the housing, and an endcap.

20. The modular lighting fixture of claim 19 further comprising the angularly-directable [extension type] *extension-type* bridge.

21. The modular lighting fixture of claim 20 wherein the angularly-directable [extension type] *extension-type* bridge is one of an L, T, and X type.

22. The modular lighting fixture of claim 19 further comprising the linear [extension type] *extension-type* bridge.

23. The modular lighting fixture of claim 19 further comprising the endcap.

24. The modular lighting fixture of claim 23 wherein the endcap has an outwardly-projecting flange adapted for seal-

## 12

ing engagement with an [outwardly presented] *outwardly-presented* face of one of the endplates.

25. The modular lighting fixture of claim 19 further comprising an elongate lens adapted for being secured to the housing.

26. The modular lighting fixture of claim 25 further comprising a gasket for providing sealing between the housing and the lens.

27. The modular lighting fixture of claim 25 wherein the lens has end edge portions, and wherein each of the endplates has an arcuate groove adapted for slideably receiving one of the end edge portions of the lens to thereby seat the lens in sealing engagement within the groove.

28. The modular lighting fixture of claim 27 wherein the groove is defined by a groove-forming portion integrally formed in each of the endplates.

29. The modular lighting fixture of claim 27 wherein:

the lens has flanges along two opposite elongate sides thereof;

the housing has downwardly-opening grooves along elongate sides thereof adapted for receiving respective ones of the flanges of the lens; and

when the endplates are attached to the housing, the grooves of the endplates are aligned with respective ones of the grooves of the housing.

30. The modular lighting fixture of claim 25 wherein the lens has a flange on each opposite longitudinal edge portion thereof, and each endplate has [laterally extending] *laterally-extending* grooves structured for receiving respective ones of the flanges.

31. The modular lighting fixture of claim 25 wherein:

the lens has a flange on each opposite longitudinal edge portion thereof;

the housing has opposite longitudinal outer portions; and each of the flanges overhangs a respective one of the longitudinal outer portions of the housing.

32. The modular lighting fixture of claim 25 wherein:

the lens has a vertical flange adjacent each opposite longitudinal edge portion thereof; and

the housing has opposite longitudinal outer portions each having downward-facing longitudinal grooves adapted for receiving respective ones of the vertical flanges.

33. The modular lighting fixture of claim 25 wherein the lens has lengthwise ends, and each endplate has an arcuate [inwardly facing] *inwardly-facing* groove for receiving a respective one of the lengthwise ends of the lens.

34. The modular lighting fixture of claim 33 wherein each endplate further comprises a gasket for sealing joinder of the respective arcuate [inwardly facing] *inwardly-facing* groove and the corresponding lengthwise end of the lens.

35. A method of modular lighting fixturing comprising:

providing an elongate first housing having *sidewalls and ends*; and

providing a pair of *unitary* endplates with respective perimeter surfaces adapted for mating attachment to either end of the first housing, each of the endplates being attachable to any of an angularly-disposing bridge, a ring, and an endcap,

wherein the bridge defines a structure adapted for angularly-directable extension of the first housing, and wherein the ring defines a structure adapted for linear extension of the first housing.