

US00RE45559E

(19) **United States**
(12) **Reissued Patent**
Williams

(10) **Patent Number:** **US RE45,559 E**
(45) **Date of Reissued Patent:** **Jun. 9, 2015**

(54) **PORTABLE COMPUTERS**
(75) Inventor: **Hilary Lyndsay Williams**, Cambridge (GB)
(73) Assignee: **Apple Inc.**, Cupertino, CA (US)
(21) Appl. No.: **13/940,105**
(22) Filed: **Jul. 11, 2013**

(58) **Field of Classification Search**
USPC 455/566, 410, 411, 550.1, 418
See application file for complete search history.

(56) **References Cited**

U.S. PATENT DOCUMENTS

2,798,907 A 7/1957 Schneider
2,945,111 A 7/1960 McCormick

(Continued)

FOREIGN PATENT DOCUMENTS

AU 2007283771 A1 4/2008
CN 1139235 A 1/1997

(Continued)

OTHER PUBLICATIONS

Hilary Lyndsay Williams, "Portable Computers", U.S. Appl. No. 12/255,557, filed Oct. 21, 2008.

(Continued)

Primary Examiner — Vladimir Magloire
(74) *Attorney, Agent, or Firm* — Novak Druce Connolly Bove + Quigg LLP

(57) **ABSTRACT**

A [portable computer] *hand held cellular telephone* arranged to rest comfortably in the hand has a small display screen. Accelerometers capable of detecting movement of the [pen] *cellular telephone* with respect to gravity provide input to a microcontroller which selects a response from a number of viewing modes. The [pen] *cellular telephone* may be held in either hand and the output message to the screen will be oriented according to the location of the [pen] *cellular telephone*. Full personal digital assistance functionality may be incorporated in a relatively small plastics casing and functions, such as calendar, [contracts] *contacts* and the like may be incorporated.

11 Claims, 10 Drawing Sheets

Related U.S. Patent Documents

Reissue of:

(64) Patent No.: **6,956,564**
Issued: **Oct. 18, 2005**
Appl. No.: **09/171,921**
PCT Filed: **Oct. 8, 1998**
PCT No.: **PCT/GB98/03016**
§ 371 (c)(1),
(2), (4) Date: **Oct. 29, 1998**
PCT Pub. No.: **WO99/22338**
PCT Pub. Date: **May 6, 1999**

U.S. Applications:

(62) Division of application No. 13/188,239, filed on Jul. 21, 2011, now Pat. No. Re. 44,855, which is a division of application No. 11/907,832, filed on Oct. 17, 2007, now Pat. No. Re. 42,738, which is an application for the reissue of Pat. No. 6,956,564.

(30) **Foreign Application Priority Data**

Oct. 28, 1997 (GB) 9722766.4

(51) **Int. Cl.**
G09G 5/00 (2006.01)
H04M 19/00 (2006.01)

(52) **U.S. Cl.**
CPC **H04M 19/00** (2013.01)

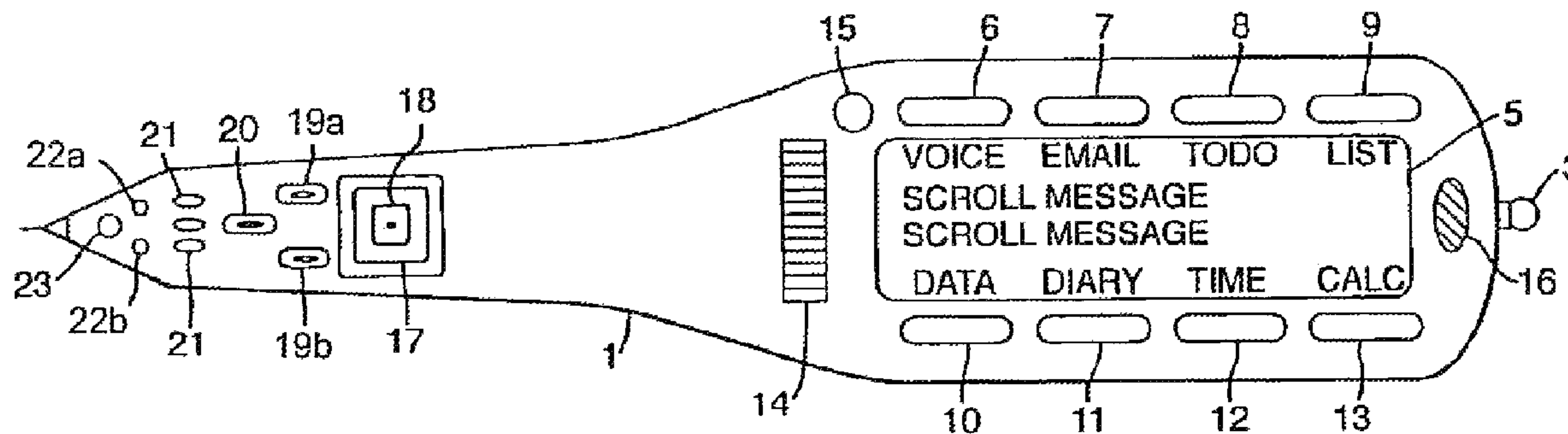

(56)

References Cited

U.S. PATENT DOCUMENTS

3,005,055 A	10/1961	Mattke	4,710,760 A	12/1987	Kasday
3,382,588 A	5/1968	Serrell et al.	4,719,524 A	1/1988	Morishima et al.
3,482,241 A	12/1969	Johnson	4,733,222 A	3/1988	Evans
3,509,298 A	4/1970	Kirk	4,734,034 A	3/1988	Maness et al.
3,662,105 A	5/1972	Hurst et al.	4,736,191 A	4/1988	Matzke et al.
3,696,409 A	10/1972	Braaten	4,739,299 A	4/1988	Eventoff et al.
3,706,867 A	12/1972	Rand et al.	4,743,895 A	5/1988	Alexander
3,721,956 A	3/1973	Hamann et al.	4,746,770 A	5/1988	McAvinney
3,790,727 A	2/1974	Laserson et al.	4,752,655 A	6/1988	Tajiri et al.
3,798,370 A	3/1974	Hurst	4,755,811 A	7/1988	Slavin et al.
3,825,730 A	7/1974	Worthington, Jr. et al.	4,763,356 A	8/1988	Day, Jr. et al.
3,846,826 A	11/1974	Mueller	4,764,717 A	8/1988	Tucker et al.
3,873,770 A	3/1975	Ioannou	4,780,764 A	10/1988	Kinoshita et al.
3,965,399 A	6/1976	Walker, Jr. et al.	4,783,829 A	11/1988	Miyakawa et al.
3,988,616 A	10/1976	Shimada	4,787,040 A	11/1988	Ames et al.
4,014,000 A	3/1977	Uno et al.	4,787,712 A	11/1988	Ukai et al.
4,070,649 A	1/1978	Wright, Jr. et al.	4,798,919 A	1/1989	Miessler et al.
4,103,252 A	7/1978	Bobick	4,806,709 A	2/1989	Evans
4,110,749 A	8/1978	Janko et al.	4,810,992 A	3/1989	Eventoff
4,115,670 A	9/1978	Chandler	4,831,359 A	5/1989	Newell
4,121,204 A	10/1978	Welch et al.	4,833,281 A	5/1989	Maples
4,129,747 A	12/1978	Pepper, Jr.	4,839,634 A	6/1989	More et al.
4,146,876 A	3/1979	Arellano et al.	4,843,568 A	6/1989	Krueger et al.
4,146,924 A	3/1979	Birk et al.	4,847,789 A	7/1989	Kelly et al.
4,158,216 A	6/1979	Bigelow	4,849,852 A	7/1989	Mullins
4,170,916 A	10/1979	Fritz et al.	4,856,993 A	8/1989	Maness et al.
4,196,429 A	4/1980	Davis	4,866,602 A	9/1989	Hall
4,241,409 A	12/1980	Nolf	4,876,524 A	10/1989	Jenkins
4,242,676 A	12/1980	Piguet et al.	4,897,511 A	1/1990	Itaya et al.
4,246,452 A	1/1981	Chandler	4,899,956 A	2/1990	King et al.
4,264,903 A	4/1981	Bigelow	4,912,662 A	3/1990	Butler et al.
4,290,052 A	9/1981	Eichelberger et al.	4,914,624 A	4/1990	Dunthorn
4,293,734 A	10/1981	Pepper, Jr.	4,917,516 A	4/1990	Retter
4,305,071 A	12/1981	Bell et al.	4,922,061 A	5/1990	Meadows et al.
4,305,131 A	12/1981	Best	4,951,036 A	8/1990	Grueter et al.
4,311,891 A	1/1982	Faust	4,954,967 A	9/1990	Takahashi
4,340,911 A	7/1982	Kato et al.	4,958,911 A	9/1990	Beiswenger et al.
4,346,376 A	8/1982	Mallos	4,969,180 A	11/1990	Watterson et al.
4,375,674 A	3/1983	Thornton	4,972,496 A	11/1990	Sklarew
4,380,007 A	4/1983	Steinegger	4,975,830 A	12/1990	Gerpheide et al.
4,380,040 A	4/1983	Posset	4,976,435 A	12/1990	Shatford et al.
4,396,945 A	8/1983	DiMatteo et al.	4,988,981 A	1/1991	Zimmerman et al.
4,435,835 A	3/1984	Sakow et al.	4,990,900 A	2/1991	Kikuchi
4,449,193 A	5/1984	Tournois	5,008,497 A	4/1991	Asher
4,475,008 A	10/1984	Doi et al.	5,023,438 A *	6/1991	Wakatsuki et al. 235/462.46
4,475,122 A	10/1984	Green	5,036,321 A	7/1991	Leach et al.
4,484,179 A	11/1984	Kasday	5,043,736 A	8/1991	Darnell et al.
4,484,346 A	11/1984	Sternberg et al.	5,045,843 A	9/1991	Hansen
4,513,183 A	4/1985	Hill	5,053,757 A	10/1991	Meadows
4,526,043 A	7/1985	Boie et al.	5,061,920 A	10/1991	Nelson
4,542,375 A	9/1985	Alles et al.	5,062,198 A	11/1991	Sun
4,550,221 A	10/1985	Mabusth	5,063,526 A	11/1991	Kagawa et al.
4,561,017 A	12/1985	Greene	5,072,294 A	12/1991	Engle
4,562,429 A	12/1985	Conway et al.	5,073,950 A	12/1991	Colbert et al.
4,564,952 A	1/1986	Karabinis	5,083,118 A	1/1992	Kazama
4,570,149 A	2/1986	Thornburg et al.	5,105,186 A	4/1992	May
4,571,454 A	2/1986	Tamaru et al.	5,113,041 A	5/1992	Blonder et al.
4,587,378 A	5/1986	Moore	5,117,071 A	5/1992	Greanias et al.
4,595,990 A	6/1986	Garwin et al.	5,119,079 A	6/1992	Hube et al.
4,613,942 A	9/1986	Chen	5,133,076 A	7/1992	Hawkins et al.
4,618,989 A	10/1986	Tsukune et al.	5,149,919 A	9/1992	Greanias et al.
4,628,160 A	12/1986	Canevari	5,153,829 A	10/1992	Furuya et al.
4,629,319 A	12/1986	Clarke et al.	5,159,159 A	10/1992	Asher
4,631,356 A	12/1986	Taguchi et al.	5,168,531 A	12/1992	Sigel
4,631,525 A	12/1986	Serravalle, Jr.	5,179,648 A	1/1993	Hauck
4,631,676 A	12/1986	Pugh	5,186,629 A	2/1993	Rohen
4,644,100 A	2/1987	Brenner et al.	5,189,404 A	2/1993	Masimo et al.
4,654,872 A	3/1987	Hisano et al.	5,203,704 A	4/1993	McCloud
4,663,669 A	5/1987	Kinoshita et al.	5,215,397 A *	6/1993	Taguchi et al. 382/3
4,669,054 A	5/1987	Schlunt et al.	5,220,324 A	6/1993	Morita
4,677,913 A	7/1987	Farace	5,227,929 A	7/1993	Comerford
4,686,332 A	8/1987	Greanias et al.	5,227,985 A	7/1993	DeMenthon
4,686,374 A	8/1987	Liptay-Wagner et al.	5,231,326 A	7/1993	Echols
4,698,461 A	10/1987	Meadows et al.	5,231,381 A	7/1993	Duwaer
4,700,022 A	10/1987	Salvador et al.	5,233,547 A	8/1993	Kapp et al.
			5,235,509 A	8/1993	Mueller et al.
			5,237,311 A	8/1993	Mailey et al.
			5,252,951 A	10/1993	Tannenbaum et al.
			5,267,327 A	11/1993	Hirayama

(56)

References Cited

U.S. PATENT DOCUMENTS

5,276,794 A	1/1994	Lamb, Jr.	5,543,588 A	8/1996	Bisset et al.
5,278,362 A	1/1994	Ohashi	5,543,591 A	8/1996	Gillespie et al.
5,293,430 A	3/1994	Shiau et al.	5,552,787 A	9/1996	Schuler et al.
5,297,030 A	3/1994	Vassigh et al.	5,559,301 A	9/1996	Bryan, Jr. et al.
5,301,222 A *	4/1994	Fujiwara 379/58	5,559,943 A	9/1996	Cyr et al.
5,305,017 A	4/1994	Gerpheide	5,561,445 A	10/1996	Miwa et al.
5,313,027 A	5/1994	Inoue et al.	5,563,996 A	10/1996	Tchao
5,313,835 A	5/1994	Dunn	5,565,658 A	10/1996	Gerpheide et al.
5,319,386 A	6/1994	Gunn et al.	5,565,887 A	10/1996	McCambridge et al.
5,327,161 A	7/1994	Logan et al.	5,566,098 A	10/1996	Lucente et al.
5,329,289 A	7/1994	Sakamoto et al.	5,570,109 A	10/1996	Jenson
5,335,557 A	8/1994	Yasutake	5,572,239 A	11/1996	Jaeger
5,339,213 A	8/1994	O'Callaghan	5,578,817 A	11/1996	Bidiville et al.
5,340,108 A	8/1994	Gerpheide et al.	5,581,243 A	12/1996	Ouellette et al.
5,341,133 A	8/1994	Savoy et al.	5,581,274 A	12/1996	Tagawa
5,345,543 A	9/1994	Capps et al.	5,581,670 A	12/1996	Bier et al.
5,345,824 A	9/1994	Sherman et al.	5,581,681 A	12/1996	Tchao et al.
5,349,303 A	9/1994	Gerpheide	5,583,543 A	12/1996	Takahashi et al.
5,357,266 A	10/1994	Tagawa	5,583,946 A	12/1996	Gourdol
5,361,387 A	11/1994	Millar et al.	5,585,823 A	12/1996	Duchon et al.
5,367,199 A	11/1994	Lefkowitz et al.	5,589,856 A	12/1996	Stein et al.
5,369,262 A	11/1994	Dvorkis et al.	5,589,893 A	12/1996	Gaughan et al.
5,374,787 A	12/1994	Miller et al.	5,590,219 A	12/1996	Gourdol
5,383,091 A	1/1995	Snell	5,592,197 A	1/1997	Tagawa
5,386,219 A	1/1995	Greanias et al.	5,592,566 A	1/1997	Pagallo et al.
5,394,096 A	2/1995	Meyer	5,592,572 A	1/1997	Le
5,396,265 A	3/1995	Ulrich et al.	5,594,776 A	1/1997	Dent
5,398,310 A	3/1995	Tchao et al.	5,594,806 A	1/1997	Colbert
5,404,152 A	4/1995	Nagai	5,594,810 A	1/1997	Gourdol
5,408,621 A	4/1995	Ben-Arie	5,598,183 A	1/1997	Robertson et al.
5,410,329 A	4/1995	Tagawa et al.	5,602,566 A	2/1997	Motosyuku et al.
5,412,189 A	5/1995	Cragun	5,603,053 A	2/1997	Gough et al.
5,414,445 A	5/1995	Kaneko et al.	5,611,060 A	3/1997	Belfiore et al.
5,416,498 A	5/1995	Grant	5,612,719 A	3/1997	Beernink et al.
5,418,760 A	5/1995	Kawashima et al.	5,613,137 A	3/1997	Bertram et al.
5,422,656 A	6/1995	Allard et al.	5,615,132 A	3/1997	Horton et al.
5,424,756 A	6/1995	Ho et al.	5,615,384 A	3/1997	Allard et al.
5,428,367 A	6/1995	Mikan	5,616,384 A	4/1997	Goettmann et al.
5,432,531 A	7/1995	Calder et al.	5,617,114 A	4/1997	Bier et al.
5,434,964 A	7/1995	Moss et al.	5,626,430 A	5/1997	Bistrack
5,438,331 A	8/1995	Gilligan et al.	5,627,531 A	5/1997	Posso et al.
5,442,347 A	8/1995	Vranish	5,632,679 A	5/1997	Tremmel
5,442,742 A	8/1995	Greyson et al.	5,638,093 A	6/1997	Takahashi et al.
D362,431 S	9/1995	Kaneko et al.	5,640,258 A	6/1997	Kurashima et al.
5,450,075 A	9/1995	Waddington	5,648,642 A	7/1997	Miller et al.
5,453,761 A	9/1995	Tanaka	5,650,597 A	7/1997	Redmayne
5,459,793 A	10/1995	Naoi et al.	5,652,569 A *	7/1997	Gerstenberger et al. ... 340/573.4
5,463,388 A	10/1995	Boie et al.	5,655,094 A	8/1997	Cline et al.
5,463,696 A	10/1995	Beernink et al.	5,656,804 A	8/1997	Barkan et al.
5,463,725 A	10/1995	Henckel et al.	5,657,012 A	8/1997	Tait
5,468,947 A	11/1995	Danielson et al.	5,661,632 A	8/1997	Register
5,473,343 A	12/1995	Kimmich et al.	5,670,985 A	9/1997	Cappels, Sr. et al.
5,473,344 A	12/1995	Bacon et al.	5,677,710 A	10/1997	Thompson-Rohrlich
5,477,237 A	12/1995	Parks	5,686,940 A	11/1997	Kuga
5,479,192 A	12/1995	Carroll, Jr. et al.	5,689,285 A	11/1997	Asher
5,479,528 A	12/1995	Speeter	5,702,323 A	12/1997	Poulton
5,483,261 A	1/1996	Yasutake	5,708,804 A	1/1998	Goodwin et al.
5,488,204 A	1/1996	Mead et al.	5,709,219 A	1/1998	Chen et al.
5,488,558 A	1/1996	Ohki	5,712,661 A	1/1998	Jaeger
5,491,495 A	2/1996	Ward et al.	5,715,524 A	2/1998	Jambhekar et al.
5,491,706 A	2/1996	Tagawa et al.	5,726,672 A	3/1998	Hernandez et al.
5,495,269 A	2/1996	Elrod et al.	5,726,685 A	3/1998	Kuth et al.
5,495,566 A	2/1996	Kwatinetz	5,726,687 A	3/1998	Belfiore et al.
5,508,703 A	4/1996	Okamura et al.	5,729,219 A	3/1998	Armstrong et al.
5,511,148 A	4/1996	Wellner	5,729,249 A	3/1998	Yasutake
5,513,309 A	4/1996	Meier et al.	5,729,604 A	3/1998	Van Schyndel
RE35,269 E	6/1996	Comerford	5,734,371 A	3/1998	Kaplan
5,523,775 A	6/1996	Capps	5,734,742 A	3/1998	Asaeda et al.
5,528,265 A	6/1996	Harrison	5,734,875 A	3/1998	Cheng
5,528,266 A	6/1996	Arbeitman et al.	5,739,451 A	4/1998	Winsky et al.
5,528,267 A	6/1996	Ise	5,745,116 A	4/1998	Pisutha-Arnond
5,534,892 A	7/1996	Tagawa	5,748,185 A	5/1998	Stephan et al.
5,534,893 A	7/1996	Hansen, Jr. et al.	5,748,785 A	5/1998	Mantell et al.
5,537,608 A	7/1996	Beatty et al.	5,749,908 A	5/1998	Snell
5,540,095 A	7/1996	Sherman et al.	5,751,274 A	5/1998	Davis
			5,753,983 A	5/1998	Dickie et al.
			5,754,645 A *	5/1998	Metroka et al. 379/58
			5,754,890 A	5/1998	Holmdahl et al.
			5,757,368 A	5/1998	Gerpheide et al.

(56)

References Cited

U.S. PATENT DOCUMENTS

5,758,267 A	5/1998	Pinder et al.	5,914,882 A	6/1999	Yeghiazarians
5,764,218 A	6/1998	Della Bona et al.	5,920,309 A	7/1999	Bisset et al.
5,767,457 A	6/1998	Gerpheide et al.	5,923,319 A	7/1999	Bishop et al.
5,777,605 A	7/1998	Yoshinobu et al.	5,923,388 A	7/1999	Kurashima et al.
5,781,630 A	7/1998	Huber et al.	5,923,757 A	7/1999	Hocker et al.
5,786,789 A	7/1998	Janky	5,923,861 A	7/1999	Bertram et al.
5,789,716 A	8/1998	Wang	5,933,778 A	8/1999	Buhrmann et al.
5,790,769 A	8/1998	Buxton et al.	5,936,613 A	8/1999	Jaeger et al.
5,793,310 A	8/1998	Watanabe et al.	5,942,733 A	8/1999	Allen et al.
5,794,164 A	8/1998	Beckert et al.	5,943,043 A	8/1999	Furuhata et al.
5,798,750 A	8/1998	Ozaki	5,943,044 A	8/1999	Martinelli et al.
5,798,756 A	8/1998	Yoshida et al.	5,943,052 A	8/1999	Allen et al.
5,805,144 A	9/1998	Scholder et al.	5,945,980 A	8/1999	Moissev et al.
5,805,145 A	9/1998	Jaeger	5,946,376 A	8/1999	Cistulli
5,805,161 A	9/1998	Tiphane	5,949,345 A	9/1999	Beckert et al.
5,808,602 A	9/1998	Sellers	5,949,408 A	9/1999	Kang et al.
5,809,166 A	9/1998	Huang et al.	5,953,001 A *	9/1999	Challener et al. 345/179
5,809,267 A	9/1998	Moran et al.	5,955,712 A	9/1999	Zakutin
5,815,142 A	9/1998	Allard et al.	5,956,019 A	9/1999	Bang et al.
5,824,904 A	10/1998	Kouhei et al.	5,956,020 A	9/1999	D'Amico et al.
5,825,351 A	10/1998	Tam	5,956,626 A	9/1999	Kaschke et al.
5,825,352 A	10/1998	Bisset et al.	5,959,611 A	9/1999	Smailagic et al.
5,825,353 A	10/1998	Will	5,966,680 A	10/1999	Butnaru
5,825,675 A	10/1998	Want et al.	5,973,668 A	10/1999	Watanabe
5,828,364 A	10/1998	Siddiqui	5,973,915 A	10/1999	Evans
5,835,061 A	11/1998	Stewart	5,982,352 A	11/1999	Pryor
5,835,079 A	11/1998	Shieh	5,982,355 A	11/1999	Jaeger et al.
5,835,083 A	11/1998	Nielsen et al.	5,982,573 A	11/1999	Henze
5,835,732 A	11/1998	Kikinis et al.	5,986,634 A	11/1999	Alioshin et al.
5,838,302 A	11/1998	Kuriyama et al.	5,991,085 A	11/1999	Rallison et al.
5,841,078 A	11/1998	Miller et al.	5,995,104 A	11/1999	Kataoka et al.
5,841,423 A	11/1998	Carroll, Jr. et al.	5,995,119 A	11/1999	Cosatto et al.
5,841,428 A	11/1998	Jaeger et al.	5,995,328 A	11/1999	Balakrishnan
5,844,547 A	12/1998	Minakuchi et al.	5,996,080 A	11/1999	Silva et al.
5,847,280 A	12/1998	Sherman et al.	6,002,389 A	12/1999	Kasser
5,847,698 A	12/1998	Reavey et al.	6,002,808 A	12/1999	Freeman
5,848,373 A	12/1998	DeLorme	6,002,963 A	12/1999	Mouchawar et al.
5,850,213 A	12/1998	Imai et al.	6,005,299 A	12/1999	Hengst
5,850,358 A	12/1998	Danielson et al.	6,008,800 A	12/1999	Pryor
5,856,822 A	1/1999	Du et al.	6,009,336 A	12/1999	Harris et al.
5,859,621 A	1/1999	Leisten	6,011,585 A	1/2000	Anderson
5,859,629 A	1/1999	Tognazzini	6,016,135 A *	1/2000	Biss et al. 345/179
5,859,631 A	1/1999	Bergman et al.	6,016,355 A	1/2000	Dickinson et al.
5,861,875 A	1/1999	Gerpheide	6,020,891 A	2/2000	Rekimoto
5,867,149 A	2/1999	Jaeger	6,021,193 A	2/2000	Thomas
5,867,158 A	2/1999	Murasaki et al.	6,025,832 A	2/2000	Sudo et al.
5,869,790 A	2/1999	Shigetaka et al.	6,028,271 A	2/2000	Gillespie et al.
5,869,791 A	2/1999	Young	6,028,602 A	2/2000	Weidenfeller et al.
5,871,251 A	2/1999	Welling et al.	6,029,214 A	2/2000	Dorfman et al.
5,874,941 A	2/1999	Yamada	6,031,518 A	2/2000	Adams et al.
5,874,942 A	2/1999	Walker	6,031,600 A	2/2000	Winner et al.
5,875,257 A	2/1999	Marrin et al.	6,034,672 A	3/2000	Gaultier et al.
5,875,311 A	2/1999	Bertram et al.	6,034,688 A	3/2000	Greenwood et al.
5,880,411 A	3/1999	Gillespie et al.	6,037,882 A	3/2000	Levy
5,883,619 A	3/1999	Ho et al.	6,037,923 A	3/2000	Suzuki
5,884,156 A	3/1999	Gordon	6,037,937 A	3/2000	Beaton et al.
5,886,735 A	3/1999	Bullister	6,041,023 A	3/2000	Lakhansingh
5,889,236 A	3/1999	Gillespie et al.	6,044,299 A	3/2000	Nilsson
5,889,511 A	3/1999	Ong et al.	6,046,877 A	4/2000	Kelsic
5,898,434 A	4/1999	Small et al.	6,057,540 A	5/2000	Gordon et al.
5,900,863 A	5/1999	Numazaki	6,057,829 A	5/2000	Silfvast
5,902,968 A *	5/1999	Sato et al. 345/179	6,061,063 A	5/2000	Wagner et al.
5,903,229 A	5/1999	Kishi	6,066,075 A	5/2000	Poulton
5,903,902 A	5/1999	Orr et al.	6,067,068 A	5/2000	Hussain
5,906,657 A	5/1999	Tognazzini	6,067,460 A	5/2000	Alanara et al.
5,907,130 A	5/1999	Suzuki	6,072,494 A	6/2000	Nguyen
5,907,152 A	5/1999	Dandliker et al.	6,073,036 A	6/2000	Heikkinen et al.
5,907,318 A	5/1999	Medina	6,075,520 A	6/2000	Inoue et al.
5,909,207 A	6/1999	Ho	6,075,533 A	6/2000	Chang
5,909,211 A	6/1999	Combs et al.	6,083,353 A	7/2000	Alexander, Jr.
5,910,797 A	6/1999	Beuk	6,084,574 A	7/2000	Bidiville
5,910,800 A	6/1999	Shields et al.	6,084,594 A	7/2000	Goto
5,910,882 A	6/1999	Burrell	6,085,112 A	7/2000	Kleinschmidt et al.
5,914,706 A	6/1999	Kono	6,091,030 A	7/2000	Tagawa et al.
5,914,708 A	6/1999	LaGrange et al.	6,091,956 A	7/2000	Hollenberg
			6,097,372 A	8/2000	Suzuki
			6,100,874 A	8/2000	Schena et al.
			6,108,426 A	8/2000	Stortz
			6,111,577 A	8/2000	Zilles et al.

(56)

References Cited

U.S. PATENT DOCUMENTS

6,115,025	A	9/2000	Buxton et al.	6,337,698	B1	1/2002	Keely, Jr. et al.
6,115,620	A	9/2000	Colonna et al.	6,340,957	B1	1/2002	Adler et al.
6,121,960	A	9/2000	Carroll et al.	6,347,290	B1	2/2002	Bartlett
6,122,526	A	9/2000	Parulski et al.	6,373,612	B1	4/2002	Hoffman et al.
6,124,587	A	9/2000	Bidiville et al.	6,380,929	B1	4/2002	Platt
6,128,003	A	10/2000	Smith et al.	6,380,931	B1	4/2002	Gillespie et al.
6,128,006	A	10/2000	Rosenberg et al.	6,393,401	B1	5/2002	Loudermilk et al.
6,128,045	A	10/2000	Anai	6,400,359	B1	6/2002	Katabami
6,130,663	A	10/2000	Null	6,407,846	B1	6/2002	Myers et al.
6,130,666	A *	10/2000	Persidsky 345/179	6,414,671	B1	7/2002	Gillespie et al.
6,137,427	A	10/2000	Binstead	6,414,672	B2	7/2002	Rekimoto et al.
6,137,468	A	10/2000	Martinez et al.	6,417,627	B1	7/2002	Derraa
6,137,481	A	10/2000	Phillipps	6,421,042	B1	7/2002	Omura et al.
6,141,014	A	10/2000	Endo et al.	6,421,046	B1	7/2002	Edgren
6,141,018	A	10/2000	Beri et al.	6,429,846	B2	8/2002	Rosenberg et al.
6,144,380	A	11/2000	Shwartz et al.	6,429,852	B1	8/2002	Adams et al.
6,147,680	A	11/2000	Tareev	6,441,806	B1	8/2002	Jaeger
6,148,261	A	11/2000	Obradovich et al.	6,446,203	B1	9/2002	Aguilar et al.
6,157,935	A	12/2000	Tran et al.	6,452,514	B1	9/2002	Phillipp
6,163,312	A	12/2000	Furuya	6,459,424	B1	10/2002	Resman
6,166,721	A	12/2000	Kuroiwa et al.	6,466,203	B2	10/2002	Van Ee
6,169,538	B1	1/2001	Nowlan et al.	6,473,069	B1	10/2002	Gerpheide
6,169,911	B1	1/2001	Wagner et al.	6,486,896	B1	11/2002	Ubillos
6,175,610	B1	1/2001	Peter	6,489,951	B1	12/2002	Wong et al.
6,181,322	B1	1/2001	Nanavati	6,492,979	B1	12/2002	Kent et al.
6,185,485	B1	2/2001	Ashrafi et al.	6,496,181	B1	12/2002	Bomer et al.
6,188,391	B1	2/2001	Seely et al.	6,498,590	B1	12/2002	Dietz et al.
6,188,392	B1 *	2/2001	O'Connor et al. 345/179	6,504,530	B1	1/2003	Wilson et al.
6,188,393	B1	2/2001	Shu	6,509,907	B1	1/2003	Kuwabara
6,191,774	B1	2/2001	Schena et al.	6,538,635	B1	3/2003	Ringot
6,198,473	B1	3/2001	Armstrong	6,552,719	B2	4/2003	Lui et al.
6,199,045	B1	3/2001	Giniger et al.	6,559,869	B1	5/2003	Lui et al.
6,199,874	B1	3/2001	Galvin et al.	6,563,492	B1	5/2003	Furuya
6,202,060	B1	3/2001	Tran	6,567,068	B2	5/2003	Rekimoto
6,208,329	B1	3/2001	Ballare	6,567,102	B2	5/2003	Kung
6,219,035	B1	4/2001	Skog	6,570,557	B1	5/2003	Westerman et al.
6,219,038	B1	4/2001	Cho	6,573,833	B1	6/2003	Rosenthal
6,222,465	B1	4/2001	Kumar et al.	6,573,883	B1	6/2003	Bartlett
6,222,528	B1	4/2001	Gerpheide et al.	6,597,347	B1	7/2003	Yasutake
6,225,976	B1	5/2001	Yates et al.	6,597,817	B1	7/2003	Silverbrook
6,225,980	B1	5/2001	Weiss et al.	6,610,936	B2	8/2003	Gillespie et al.
6,227,966	B1	5/2001	Yokoi	6,624,824	B1	9/2003	Tognazzini et al.
6,232,937	B1	5/2001	Jacobsen et al.	6,639,586	B2	10/2003	Gerpheide
6,236,386	B1	5/2001	Watanabe	6,657,615	B2	12/2003	Harada
6,239,389	B1	5/2001	Allen et al.	6,661,409	B2	12/2003	Demartines et al.
6,239,788	B1	5/2001	Nohno et al.	6,664,982	B1	12/2003	Bi
6,243,074	B1	6/2001	Fishkin	6,677,932	B1	1/2004	Westerman
6,243,075	B1	6/2001	Fishkin et al.	6,677,965	B1	1/2004	Ullmann et al.
6,243,080	B1	6/2001	Molne	6,680,731	B2	1/2004	Gerpheide et al.
6,255,604	B1	7/2001	Tokioka et al.	6,681,120	B1	1/2004	Kim
6,256,011	B1	7/2001	Culver	6,683,628	B1	1/2004	Nakagawa et al.
6,256,020	B1	7/2001	Pabon et al.	6,686,910	B2	2/2004	O'Donnell, Jr.
6,259,405	B1	7/2001	Stewart et al.	6,690,365	B2	2/2004	Hinckley et al.
6,262,717	B1	7/2001	Donohue et al.	6,690,387	B2	2/2004	Zimmerman et al.
6,266,050	B1	7/2001	Oh et al.	RE38,471	E	3/2004	Howard et al.
6,268,857	B1	7/2001	Fishkin et al.	6,707,449	B2	3/2004	Hinckley et al.
6,278,441	B1	8/2001	Gouzman et al.	6,714,221	B1	3/2004	Christie et al.
6,278,443	B1	8/2001	Amro et al.	6,720,949	B1	4/2004	Pryor et al.
6,278,884	B1	8/2001	Kim	6,727,891	B2	4/2004	Moriya et al.
6,297,795	B1	10/2001	Kato et al.	6,730,863	B1	5/2004	Gerpheide et al.
6,297,805	B1	10/2001	Adler et al.	6,734,845	B1	5/2004	Nielsen et al.
6,297,811	B1	10/2001	Kent et al.	6,741,996	B1	5/2004	Brechner et al.
6,297,838	B1	10/2001	Chang et al.	6,747,692	B2	6/2004	Patel et al.
6,300,933	B1	10/2001	Nagasaki et al.	6,750,848	B1	6/2004	Pryor
6,308,134	B1	10/2001	Croyle et al.	6,785,578	B2	8/2004	Johnson et al.
6,310,610	B1	10/2001	Beaton et al.	6,788,815	B2	9/2004	Lui et al.
6,310,666	B1	10/2001	Moon	6,791,530	B2	9/2004	Vernier et al.
6,311,162	B1	10/2001	Reichwein et al.	6,809,724	B1	10/2004	Shiraishi
6,313,849	B1	11/2001	Takase et al.	6,822,634	B1	11/2004	Kemp et al.
6,313,853	B1	11/2001	Lamontagne et al.	6,839,721	B2	1/2005	Schwols
6,323,845	B1	11/2001	Robbins	6,847,354	B2	1/2005	Vranish
6,323,846	B1	11/2001	Westerman et al.	6,856,259	B1	2/2005	Sharp
6,330,009	B1	12/2001	Murasaki et al.	6,873,312	B2	3/2005	Matsueda
6,330,149	B1	12/2001	Burrell	6,873,313	B2	3/2005	Washio et al.
6,335,727	B1	1/2002	Morishita et al.	6,888,532	B2	5/2005	Wong et al.
				6,888,536	B2	5/2005	Westerman et al.
				6,891,531	B2	5/2005	Lin
				6,903,927	B2	6/2005	Anlauff
				6,907,575	B2	6/2005	Duarte

(56)

References Cited

U.S. PATENT DOCUMENTS

6,912,462 B2	6/2005	Ogaki	7,400,318 B2	7/2008	Gerpheide et al.
6,920,619 B1	7/2005	Milekic	7,411,575 B2	8/2008	Hill et al.
6,924,790 B1	8/2005	Bi	7,420,376 B2	9/2008	Tola et al.
6,931,309 B2	8/2005	Phelan et al.	7,439,962 B2	10/2008	Reynolds et al.
6,938,222 B2	8/2005	Hullender et al.	7,446,783 B2	11/2008	Grossman
6,956,564 B1	10/2005	Williams	7,450,113 B2	11/2008	Gillespie et al.
6,957,392 B2	10/2005	Simister et al.	7,450,114 B2	11/2008	Anwar
6,958,749 B1	10/2005	Matsushita et al.	7,459,723 B2	12/2008	Okada et al.
RE38,896 E	11/2005	Anderson	7,469,381 B2	12/2008	Ording
6,970,160 B2	11/2005	Mulligan et al.	7,479,949 B2	1/2009	Jobs et al.
6,972,749 B2	12/2005	Hinckley et al.	7,499,036 B2	3/2009	Flowers
6,972,776 B2	12/2005	Davis et al.	7,508,375 B2	3/2009	Liu
6,975,306 B2	12/2005	Hinckley et al.	7,511,702 B2	3/2009	Hotelling
6,999,779 B1	2/2006	Hashimoto	7,532,205 B2	5/2009	Gillespie et al.
7,002,821 B2	2/2006	Gerpheide	7,561,159 B2	7/2009	Abel et al.
7,009,599 B2	3/2006	Pihlaja	7,567,240 B2	7/2009	Peterson, Jr. et al.
7,009,626 B2	3/2006	Anwar	RE40,867 E	8/2009	Binstead
7,015,894 B2	3/2006	Morohoshi	7,573,459 B2	8/2009	Shih et al.
7,030,860 B1	4/2006	Hsu et al.	7,576,732 B2	8/2009	Lii
7,030,861 B1	4/2006	Westerman et al.	7,598,949 B2	10/2009	Han
7,030,862 B2	4/2006	Nozaki	7,612,786 B2	11/2009	Vale et al.
7,046,230 B2	5/2006	Zadesky et al.	7,614,019 B2	11/2009	Rimas Ribikauskas et al.
7,053,886 B2	5/2006	Shin	7,639,238 B2	12/2009	Hauck
7,061,474 B2	6/2006	Hinckley et al.	7,658,675 B2	2/2010	Hotta
7,075,512 B1	7/2006	Fabre et al.	7,663,607 B2	2/2010	Hotelling et al.
7,081,886 B2	7/2006	Nakano et al.	7,667,884 B2	2/2010	Chui
7,084,859 B1	8/2006	Pryor	7,701,442 B2	4/2010	Wong et al.
7,088,346 B2	8/2006	Krajewski et al.	7,705,924 B2	4/2010	Kim
7,088,374 B2	8/2006	David et al.	7,710,407 B2	5/2010	Trent, Jr. et al.
7,098,897 B2	8/2006	Vakil et al.	7,719,523 B2	5/2010	Hillis
7,102,626 B2	9/2006	Denny, III	7,724,242 B2	5/2010	Hillis et al.
7,109,978 B2	9/2006	Gillespie et al.	7,728,821 B2	6/2010	Hillis et al.
7,117,453 B2	10/2006	Drucker et al.	7,735,016 B2	6/2010	Celik et al.
7,124,315 B2	10/2006	Espinoza-Ibarra et al.	7,768,503 B2	8/2010	Chiu et al.
7,126,157 B2	10/2006	Okada et al.	7,786,975 B2	8/2010	Ording et al.
7,129,935 B2	10/2006	Mackey	7,796,104 B2	9/2010	Kim
7,136,213 B2	11/2006	Chui	7,808,255 B2	10/2010	Hristov et al.
7,138,971 B2	11/2006	Miyazaki	7,812,826 B2	10/2010	Ording et al.
7,138,983 B2	11/2006	Wakai et al.	7,812,827 B2	10/2010	Hotelling et al.
7,152,210 B1	12/2006	Van Den Hoven et al.	7,821,502 B2	10/2010	Hristov
7,154,481 B2	12/2006	Cross et al.	7,825,885 B2	11/2010	Sato et al.
7,154,534 B2	12/2006	Seki et al.	7,825,905 B2	11/2010	Philipp
7,155,048 B2	12/2006	Ohara	7,839,391 B2	11/2010	Varian et al.
7,158,121 B2	1/2007	Krajewski et al.	7,843,429 B2	11/2010	Pryor
7,169,996 B2	1/2007	Georges et al.	7,844,913 B2	11/2010	Amano et al.
7,173,623 B2	2/2007	Calkins et al.	7,844,915 B2	11/2010	Platzer et al.
7,180,500 B2	2/2007	Marvit et al.	7,864,160 B2	1/2011	Geaghan et al.
7,181,373 B2	2/2007	Le Cocq et al.	7,868,874 B2	1/2011	Reynolds
7,184,064 B2	2/2007	Zimmerman et al.	7,872,640 B2	1/2011	Lira
7,184,796 B2	2/2007	Karidis et al.	7,874,923 B2	1/2011	Mattice et al.
7,202,857 B2	4/2007	Hinckley et al.	7,907,124 B2	3/2011	Hillis et al.
7,218,314 B2	5/2007	Itoh	7,907,125 B2	3/2011	Weiss et al.
7,236,161 B2	6/2007	Geaghan et al.	7,920,129 B2	4/2011	Hotelling et al.
7,240,291 B2	7/2007	Card et al.	7,924,271 B2	4/2011	Christie et al.
7,242,136 B2	7/2007	Kim et al.	7,932,898 B2	4/2011	Philipp et al.
7,254,775 B2	8/2007	Geaghan et al.	7,948,477 B2	5/2011	Hotelling
7,256,767 B2	8/2007	Wong et al.	7,956,847 B2	6/2011	Christie
7,274,353 B2	9/2007	Chiu et al.	7,995,030 B2	8/2011	Joung et al.
7,283,126 B2	10/2007	Leung	RE42,738 E	9/2011	Williams
7,292,229 B2	11/2007	Morag et al.	8,031,180 B2	10/2011	Miyamoto et al.
7,304,621 B2	12/2007	Oomori et al.	RE44,103 E	3/2013	Williams
7,304,691 B2	12/2007	Song et al.	1,061,578 A1	5/2013	Wischhusen et al.
7,337,412 B2	2/2008	Guido et al.	2001/0035880 A1	11/2001	Musatov et al.
RE40,153 E	3/2008	Westerman et al.	2001/0045949 A1	11/2001	Chithambaram et al.
7,339,580 B2	3/2008	Westerman et al.	2002/0015024 A1	2/2002	Westerman et al.
7,345,889 B1	3/2008	Norte	2002/0015064 A1	2/2002	Robotham et al.
7,346,850 B2	3/2008	Swartz et al.	2002/0018051 A1	2/2002	Singh
7,355,620 B2	4/2008	Ikehata et al.	2002/0036618 A1	3/2002	Wakai et al.
7,356,575 B1	4/2008	Shapiro	2002/0056575 A1	5/2002	Keely et al.
7,362,313 B2	4/2008	Geaghan et al.	2002/0067346 A1	6/2002	Mouton
7,362,396 B2	4/2008	Jeoung et al.	2002/0130839 A1	9/2002	Wallace et al.
7,372,455 B2	5/2008	Perski et al.	2002/0152045 A1	10/2002	Dowling et al.
7,382,139 B2	6/2008	Mackey	2002/0158838 A1	10/2002	Smith et al.
7,385,544 B2	6/2008	Chia	2002/0186210 A1	12/2002	Itoh
7,385,593 B2	6/2008	Krajewski et al.	2002/0191029 A1	12/2002	Gillespie et al.
			2002/0194589 A1	12/2002	Cristofalo et al.
			2003/0016252 A1	1/2003	Noy et al.
			2003/0076306 A1	4/2003	Zadesky et al.
			2003/0076343 A1	4/2003	Fishkin et al.

(56)

References Cited

U.S. PATENT DOCUMENTS

2003/0085870	A1	5/2003	Hinckley	2006/0031786	A1	2/2006	Hillis et al.
2003/0095096	A1	5/2003	Robbin et al.	2006/0033751	A1	2/2006	Keely et al.
2003/0095135	A1	5/2003	Kaasila et al.	2006/0038796	A1	2/2006	Hinckley et al.
2003/0095697	A1	5/2003	Wood et al.	2006/0044259	A1	3/2006	Hotelling et al.
2003/0098858	A1	5/2003	Perski et al.	2006/0047386	A1	3/2006	Kanevsky et al.
2003/0122787	A1	7/2003	Zimmerman et al.	2006/0048073	A1	3/2006	Jarrett et al.
2003/0132959	A1	7/2003	Simister et al.	2006/0049920	A1	3/2006	Sadler et al.
2003/0159567	A1	8/2003	Subotnick	2006/0055662	A1	3/2006	Rimas-Ribikauskas et al.
2003/0160832	A1	8/2003	Ridgley et al.	2006/0055669	A1	3/2006	Das
2003/0167119	A1	9/2003	Cherveney	2006/0061551	A1	3/2006	Fateh
2003/0174149	A1	9/2003	Fujisaki et al.	2006/0077544	A1	4/2006	Stark
2003/0184525	A1	10/2003	Tsai	2006/0082549	A1	4/2006	Hoshino et al.
2003/0184593	A1	10/2003	Dunlop	2006/0084852	A1	4/2006	Mason et al.
2003/0193481	A1	10/2003	Sokolsky	2006/0092142	A1	5/2006	Gillespie et al.
2003/0210286	A1	11/2003	Gerpheide et al.	2006/0094502	A1	5/2006	Katayama et al.
2003/0231168	A1	12/2003	Bell et al.	2006/0097991	A1	5/2006	Hotelling et al.
2004/0012572	A1	1/2004	Sowden et al.	2006/0101354	A1	5/2006	Hashimoto et al.
2004/0021676	A1	2/2004	Chen et al.	2006/0125799	A1	6/2006	Hillis et al.
2004/0021694	A1	2/2004	Doar	2006/0132460	A1	6/2006	Kolmykov-Zotov et al.
2004/0021698	A1	2/2004	Baldwin et al.	2006/0156249	A1	7/2006	Blythe et al.
2004/0027398	A1	2/2004	Jaeger	2006/0164399	A1	7/2006	Cheston et al.
2004/0034801	A1	2/2004	Jaeger	2006/0181510	A1	8/2006	Faith
2004/0056837	A1	3/2004	Koga et al.	2006/0181519	A1	8/2006	Vernier et al.
2004/0080541	A1	4/2004	Saiga et al.	2006/0187215	A1	8/2006	Rosenberg et al.
2004/0100479	A1	5/2004	Nakano et al.	2006/0190833	A1	8/2006	SanGiovanni et al.
2004/0108995	A1	6/2004	Hoshino et al.	2006/0197753	A1	9/2006	Hotelling
2004/0119700	A1	6/2004	Ichikawa	2006/0202953	A1	9/2006	Pryor et al.
2004/0155871	A1	8/2004	Perski et al.	2006/0207806	A1	9/2006	Philipp
2004/0155888	A1	8/2004	Padgitt et al.	2006/0210958	A1	9/2006	Rimas-Ribikauskas et al.
2004/0160420	A1	8/2004	Baharav et al.	2006/0227114	A1	10/2006	Geaghan et al.
2004/0161132	A1	8/2004	Cohen et al.	2006/0227116	A1	10/2006	Zotov et al.
2004/0167919	A1	8/2004	Sterling et al.	2006/0236263	A1	10/2006	Bathiche et al.
2004/0189720	A1	9/2004	Wilson et al.	2006/0238495	A1	10/2006	Davis
2004/0196270	A1	10/2004	Chiu et al.	2006/0250377	A1	11/2006	Zadesky et al.
2004/0215643	A1	10/2004	Brechner et al.	2006/0253793	A1	11/2006	Zhai et al.
2004/0224638	A1	11/2004	Fadell et al.	2006/0267959	A1	11/2006	Goto et al.
2004/0263486	A1	12/2004	Seni	2006/0274046	A1	12/2006	Hillis et al.
2005/0012723	A1	1/2005	Pallakoff	2006/0274055	A1	12/2006	Reynolds et al.
2005/0014364	A1	1/2005	Chen et al.	2006/0288313	A1	12/2006	Hillis
2005/0024341	A1	2/2005	Gillespie et al.	2006/0294472	A1	12/2006	Cheng et al.
2005/0030255	A1	2/2005	Chiu et al.	2007/0008066	A1	1/2007	Fukuda
2005/0041385	A1	2/2005	Kikinis et al.	2007/0024646	A1	2/2007	Saarinen et al.
2005/0046621	A1	3/2005	Kaikuranta	2007/0028191	A1	2/2007	Tsuji
2005/0052427	A1	3/2005	Wu et al.	2007/0034423	A1	2/2007	Rebeschi et al.
2005/0057524	A1	3/2005	Hill et al.	2007/0035513	A1	2/2007	Sherrard et al.
2005/0073324	A1	4/2005	Umeda et al.	2007/0046646	A1	3/2007	Kwon et al.
2005/0088418	A1	4/2005	Nguyen	2007/0055967	A1	3/2007	Poff et al.
2005/0088443	A1	4/2005	Blanco et al.	2007/0064004	A1	3/2007	Bonner et al.
2005/0093868	A1	5/2005	Hinckley	2007/0067745	A1	3/2007	Choi et al.
2005/0110769	A1	5/2005	DaCosta et al.	2007/0075965	A1	4/2007	Huppi et al.
2005/0114788	A1	5/2005	Fabritius	2007/0109275	A1	5/2007	Chuang
2005/0145807	A1	7/2005	Lapstun et al.	2007/0109279	A1	5/2007	Sigona
2005/0168353	A1	8/2005	Dement et al.	2007/0120835	A1	5/2007	Sato
2005/0168488	A1	8/2005	Montague	2007/0132789	A1	6/2007	Ording et al.
2005/0190144	A1	9/2005	Kong	2007/0146337	A1	6/2007	Ording et al.
2005/0193015	A1	9/2005	Logston et al.	2007/0150826	A1	6/2007	Anzures et al.
2005/0193351	A1	9/2005	Huoviala	2007/0150842	A1	6/2007	Chaudhri et al.
2005/0195154	A1	9/2005	Robbins et al.	2007/0152978	A1	7/2007	Kocienda et al.
2005/0198588	A1	9/2005	Lin et al.	2007/0152979	A1	7/2007	Jobs et al.
2005/0212754	A1	9/2005	Marvit et al.	2007/0152984	A1	7/2007	Ording et al.
2005/0237308	A1	10/2005	Autio et al.	2007/0155434	A1	7/2007	Jobs et al.
2005/0270269	A1	12/2005	Tokkonen	2007/0156364	A1	7/2007	Rothkopf
2005/0270273	A1	12/2005	Marten	2007/0157094	A1	7/2007	Lemay et al.
2005/0275618	A1	12/2005	Juh et al.	2007/0174257	A1	7/2007	Howard
2006/0001650	A1	1/2006	Robbins et al.	2007/0185876	A1	8/2007	Mendis et al.
2006/0001652	A1	1/2006	Chiu et al.	2007/0236475	A1	10/2007	Wherry
2006/0007174	A1	1/2006	Shen	2007/0247435	A1	10/2007	Benko et al.
2006/0007176	A1	1/2006	Shen	2007/0252821	A1	11/2007	Holleman et al.
2006/0007178	A1	1/2006	Davis	2007/0256026	A1	11/2007	Klassen et al.
2006/0012575	A1	1/2006	Knapp et al.	2007/0257891	A1	11/2007	Esenher et al.
2006/0022955	A1	2/2006	Kennedy	2007/0262964	A1	11/2007	Zotov et al.
2006/0022956	A1	2/2006	Lengeling et al.	2007/0273560	A1	11/2007	Hua et al.
2006/0025218	A1	2/2006	Hotta	2008/0005703	A1	1/2008	Radivojevic et al.
2006/0026521	A1	2/2006	Hotelling et al.	2008/0006454	A1	1/2008	Hotelling
2006/0028428	A1	2/2006	Dai et al.	2008/0016096	A1	1/2008	Wilding et al.
				2008/0034029	A1	2/2008	Fang et al.
				2008/0046425	A1	2/2008	Perski
				2008/0048978	A1	2/2008	Trent et al.
				2008/0052945	A1	3/2008	Matas et al.

(56)

References Cited

U.S. PATENT DOCUMENTS

2008/0062207 A1 3/2008 Park
 2008/0084400 A1 4/2008 Rosenberg
 2008/0088595 A1 4/2008 Liu et al.
 2008/0088602 A1 4/2008 Hotelling
 2008/0094369 A1 4/2008 Ganatra et al.
 2008/0094370 A1 4/2008 Ording et al.
 2008/0104544 A1 5/2008 Collins et al.
 2008/0138589 A1 6/2008 Wakabayashi et al.
 2008/0143683 A1 6/2008 Hotelling
 2008/0158167 A1 7/2008 Hotelling et al.
 2008/0158198 A1 7/2008 Elias
 2008/0168395 A1 7/2008 Ording et al.
 2008/0168404 A1 7/2008 Ording
 2008/0180404 A1 7/2008 Han et al.
 2008/0204426 A1 8/2008 Hotelling et al.
 2008/0231603 A1 9/2008 Parkinson et al.
 2008/0231610 A1 9/2008 Hotelling et al.
 2008/0284925 A1 11/2008 Han
 2008/0288856 A1 11/2008 Goranson et al.
 2009/0244020 A1 10/2009 Sjolín
 2009/0259969 A1 10/2009 Pallakoff
 2009/0284478 A1 11/2009 De La Torre Baltierra et al.
 2009/0307623 A1 12/2009 Agarawala et al.
 2010/0097346 A1 4/2010 Sleeman
 2010/0172624 A1 7/2010 Watts
 2011/0022991 A1 1/2011 Hillis et al.
 2011/0025912 A1 2/2011 Regler

FOREIGN PATENT DOCUMENTS

CN 1455615 A 11/2003
 CN 1139235 C 2/2004
 CN 1695105 A 11/2005
 CN 17541 3/2006
 DE 3615742 A1 11/1987
 DE 4434773 A1 4/1996
 DE 4445023 A1 6/1996
 DE 19722636 A1 12/1998
 DE 10022537 A1 11/2000
 DE 102008052485 A1 4/2010
 EP 0156593 A2 10/1985
 EP 0178157 4/1986
 EP 0178157 B1 4/1986
 EP 0269364 A2 6/1988
 EP 0439340 B1 7/1991
 EP 0450196 A1 10/1991
 EP 0498540 B1 1/1992
 EP 0498540 A2 8/1992
 EP 0507269 B1 10/1992
 EP 0609021 A2 8/1994
 EP 0615209 B1 9/1994
 EP 0622722 A2 11/1994
 EP 0658894 6/1995
 EP 0658894 A1 6/1995
 EP 0658894 B1 6/1995
 EP 0674288 A1 9/1995
 EP 0701220 3/1996
 EP 0731407 A1 9/1996
 EP 0731407 B1 9/1996
 EP 0551778 B1 1/1997
 EP 0757437 A2 2/1997
 EP 0757437 B1 2/1997
 EP 0827064 A2 3/1998
 EP 0827094 A2 3/1998
 EP 0880091 A2 11/1998
 EP 0917077 A2 5/1999
 EP 0944218 A1 9/1999
 EP 0982732 A1 3/2000
 EP 1026713 A1 8/2000
 EP 1026713 B1 8/2000
 EP 1028425 A2 8/2000
 EP 0880091 B1 12/2004
 EP 1507228 A1 2/2005
 EP 1517228 A2 3/2005

FR 2662528 A1 11/1991
 FR 2686440 A1 7/1993
 GB 2072389 9/1981
 GB 2072389 A 9/1981
 GB 2315186 A 1/1998
 GB 2315186 B 1/1998
 GB 2319591 A 5/1998
 GB 2347200 A 8/2000
 GB 2351215 A 12/2000
 GB 2448319 A 10/2008
 JP 50-127328 10/1975
 JP 51-022325 2/1976
 JP 57-175228 10/1982
 JP 59-087583 5/1984
 JP 60-123927 7/1985
 JP 61-028122 2/1986
 JP 61117619 A2 6/1986
 JP 61124009 A2 6/1986
 JP 63106826 A2 5/1988
 JP 63181022 A2 7/1988
 JP 63298518 A2 12/1988
 JP 1-142818 6/1989
 JP 2-40614 2/1990
 JP 2-140822 5/1990
 JP 2-144716 6/1990
 JP 3-271976 B2 12/1991
 JP 4-32920 A 2/1992
 JP 04032920 A 2/1992
 JP 4-128330 B2 4/1992
 JP 5-41135 A 2/1993
 JP 05041135 A2 2/1993
 JP 5-80938 A 4/1993
 JP 5-101741 A 4/1993
 JP 05080938 A2 4/1993
 JP 05101741 A2 4/1993
 JP 5-189110 A 7/1993
 JP 05189110 A2 7/1993
 JP 5-205565 A 8/1993
 JP 5-211021 A 8/1993
 JP 5-217464 A 8/1993
 JP 05205565 A2 8/1993
 JP 05211021 A2 8/1993
 JP 05217464 A2 8/1993
 JP 5-233141 A 9/1993
 JP 05233141 A 9/1993
 JP 5-265656 A 10/1993
 JP 5-274956 A 10/1993
 JP 05265656 A2 10/1993
 JP 05274956 A2 10/1993
 JP 5-289811 A 11/1993
 JP 5-298955 A 11/1993
 JP 05289811 A 11/1993
 JP 05298955 A2 11/1993
 JP 5-325723 A 12/1993
 JP 05325723 A2 12/1993
 JP 6-089636 A 3/1994
 JP 06089636 A2 3/1994
 JP 6-096639 A 4/1994
 JP 6-111685 A 4/1994
 JP 6-111695 A 4/1994
 JP 06096639 A2 4/1994
 JP 06111685 A2 4/1994
 JP 06111695 A2 4/1994
 JP 6-139879 A 5/1994
 JP 06139879 A2 5/1994
 JP 6-6161661 6/1994
 JP 6-187078 A 7/1994
 JP 6-208433 A 7/1994
 JP 06187078 A 7/1994
 JP 06208433 A 7/1994
 JP 6-267382 A 9/1994
 JP 06267382 A2 9/1994
 JP 6-283993 A 10/1994
 JP 06283993 A2 10/1994
 JP 6-333459 A 12/1994
 JP 06333459 A2 12/1994
 JP 7-107574 A 4/1995
 JP 07107574 A2 4/1995
 JP 7-201249 A 8/1995

(56)

References Cited

FOREIGN PATENT DOCUMENTS

JP 7-201256 A 8/1995
 JP 7-230352 8/1995
 JP 07201249 A2 8/1995
 JP 07201256 A 8/1995
 JP 7-253838 A 10/1995
 JP 7-261922 A 10/1995
 JP 07253838 A2 10/1995
 JP 7261899 A 10/1995
 JP 07261899 A2 10/1995
 JP 07261922 A2 10/1995
 JP 7287689 10/1995
 JP 7-296670 A 11/1995
 JP 07296670 A 11/1995
 JP 7-319001 A 12/1995
 JP 07319001 A2 12/1995
 JP 8-016292 A 1/1996
 JP 08016292 A2 1/1996
 JP 8-115158 A 5/1996
 JP 08115158 A2 5/1996
 JP 8-203387 A 8/1996
 JP 08203387 A2 8/1996
 JP 8-293226 A 11/1996
 JP 8-298045 A 11/1996
 JP 8-299541 A 11/1996
 JP 8-316664 A 11/1996
 JP 08293226 A2 11/1996
 JP 08298045 A2 11/1996
 JP 08299541 A2 11/1996
 JP 08316664 A2 11/1996
 JP 9-044289 A 2/1997
 JP 09044289 A2 2/1997
 JP 9-069023 A 3/1997
 JP 09069023 A2 3/1997
 JP 9-128148 A 5/1997
 JP 09128148 A2 5/1997
 JP 9-218747 A 8/1997
 JP 09218747 A2 8/1997
 JP 9-230993 A 9/1997
 JP 9-231858 A 9/1997
 JP 9-251347 A 9/1997
 JP 09230993 A2 9/1997
 JP 09231858 A2 9/1997
 JP 09251347 A2 9/1997
 JP 09288926 11/1997
 JP 09288926 A2 11/1997
 JP 10-074429 3/1998
 JP 10-074429 A 3/1998
 JP 10074429 A2 3/1998
 JP 10-198507 A 7/1998
 JP 63-167923 7/1998
 JP 10198507 A2 7/1998
 JP 10-227878 A 8/1998
 JP 10227878 A2 8/1998
 JP 10-326149 A 12/1998
 JP 10326149 A2 12/1998
 JP 11-505641 5/1999
 JP 11-184607 A 7/1999
 JP 11-194863 A 7/1999
 JP 11-194872 A 7/1999
 JP 11-194882 A 7/1999
 JP 11-194883 A 7/1999
 JP 11-194891 7/1999
 JP 11-195353 A 7/1999
 JP 11-203045 A 7/1999
 JP 11184607 A2 7/1999
 JP 11194863 A2 7/1999
 JP 11194872 A2 7/1999
 JP 11194882 A2 7/1999
 JP 11194883 A2 7/1999
 JP 11194891 A2 7/1999
 JP 11195353 A2 7/1999
 JP 11203045 A2 7/1999
 JP 2000-137555 A 5/2000
 JP 2000-163031 6/2000
 JP 2000-163193 A 6/2000

JP 2000-163443 A 6/2000
 JP 2000-163444 A 6/2000
 JP 2000-222130 A 8/2000
 JP 2001-137564 A 5/2001
 JP 3-194819 B2 8/2001
 JP 2002-342033 A 11/2002
 JP 2005-44036 2/2005
 JP 2005-234291 9/2005
 JP 2009-544996 A 12/2009
 JP 4542637 9/2010
 KR 2002-0095992 A 12/2002
 KR 2004-0071767 8/2004
 KR 2007-0064869 A 6/2007
 WO 91/03039 A1 3/1991
 WO 93/14589 A1 7/1993
 WO 94/17494 8/1994
 WO 94/17494 A2 8/1994
 WO 94/29788 12/1994
 WO 95/00897 1/1995
 WO 95/00897 A1 1/1995
 WO 95/04327 2/1995
 WO 95/04327 9/1995
 WO 95/27334 10/1995
 WO 96/07966 3/1996
 WO 96/18179 6/1996
 WO 96/35288 11/1996
 WO 98/06054 2/1998
 WO 98/07112 A2 2/1998
 WO 98/14863 4/1998
 WO 98/14863 A2 4/1998
 WO 98/30967 7/1998
 WO 99/22338 5/1999
 WO 99/22338 A1 5/1999
 WO 99/28812 A1 6/1999
 WO 99/38149 7/1999
 WO 99/38149 A1 7/1999
 WO 99/40562 8/1999
 WO 99/49443 9/1999
 WO 99/49443 A2 9/1999
 WO 99/57630 A1 11/1999
 WO 00/44018 7/2000
 WO 01/29702 4/2001
 WO 02/01338 1/2002
 WO 03/054681 A1 7/2003
 WO 03/060622 7/2003
 WO 03/081458 10/2003
 WO 2005/052773 6/2005
 WO 2006/003591 6/2005
 WO 2005/073834 8/2005
 WO 2005/114369 12/2005
 WO 2006/020305 2/2006
 WO 2006/067711 A2 6/2006
 WO 2008/030563 A2 3/2008
 WO 2008/085848 A1 7/2008
 WO 2008/085871 A1 7/2008
 WO 2008/085877 A1 7/2008
 WO 2008/086218 7/2008
 WO 2010/026106 3/2010
 WO 2010/041826 4/2010
 WO 2010/134729 11/2010
 WO 2011/045805 4/2011

OTHER PUBLICATIONS

Hilary Lyndsay Williams, "Portable Computers", U.S. Appl. No. 12/268,336, filed Nov. 10, 2008.
 Hilary Lyndsay Williams, "Portable Computers", U.S. Appl. No. 12/268,254, filed Nov. 10, 2008.
 Ed Brown, William A.S. Buxton and Kevin Murtagh, "Windows on Tablets as a Means of Achieving Virtual Input Devices," Proc. of the IFIP TC 13, Cambridge, U.K., Aug. 27-31, 1990.
 "Technology," Wacom Co., Ltd., Saitama, Japan, 2002.
 Subutai Ahmad "A Usable Real-Time 3D Hand Tracker," In Proceedings 28th Asilomar Conference on Signals, Systems and Computers, pp. 1257-1261, 1995.
 "Triax custom controllers due; video game controllers," HFD—The Weekly Home Furnishings Newspaper, vol. 67, No. 1, p. 122, Jan. 4, 1993.

(56)

References Cited

OTHER PUBLICATIONS

- Travis Butler, "Portable MP3: The Nomad Jukebox," TidBITS # 562, 2001.
- Franklin Tessler, "Touchpads," Macworld, v. 13, No. 2, p. 68, Mac Publishing, Feb. 1996.
- Richard Nass, "Touchpad input device goes digital to gie portable systems a desktop 'mouse-like' feel," Electronic Design, vol. 44, No. 18, p. 51, Sep. 3, 1996.
- Easy Lai, "Touchpad," Notebook PC Manual, Beijing Acer Information Co., Ltd., Beijing, China, Feb. 16, 2005.
- "Tips for Typing," FingerWorks, Newark, NJ, retrieved from http://www.fingerworks.com/mini_typing.html on Jan. 10, 2008.
- Kenneth B. Evans, Peter P. Tanner and Marcelli Wein, "Tablet-Based Valuers That Provide One, Two, or Three Degrees of Freedom," Computer Graphics, v. 15, No. 3, Aug. 1981.
- "Synaptics TouchPad Interfacing Guide," Synaptics, Inc., San Jose, CA, Jan. 22, 2001, second edition.
- Michael Chen, S. Joy Mountford and Abigail Sellen, "A Study in Interactive 3-D Rotation Using 2-D Control Devices," Computer Graphics, v. 22, No. 4, Aug. 1988, pp. 121-129.
- Jun Rekimoto, "SmartSkin: An Infrastructure for Freehand Manipulation on Interactive Surfaces," Proc. of the SIGCHI, pp. 113-120, Minneapolis, USA, 2002.
- Franklin N. Tessler, "Smart input: how to choose from the new generation of innovative input devices," Macworld, v. 13, No. 5, p. 98, May 1996.
- Lars G. Soderholm, "Sensing Systems for 'Touch and Feel'," Design News, Aug. 5, 1989.
- "Design News: Product News," Design News, Cahners Publication, issue 11, Jun. 9, 1997.
- "Design News: Product News," Design News, Cahners Publication, issue 9, May 5, 1997.
- "Preview of Exhibitor Booths at the Philadelphia Show," The Air Conditioning, Heating and Refrigeration News, Business News Publishing Co., Jan. 13, 1997.
- Franklin Tessler, "Point Pad," Macworld, Oct 1995, v. 12, No. 10, p. 87.
- "Personal Jukebox (PJB): Systems Research Center and PAAD," Compaq Computer Corp., Oct. 13, 2000, <http://research.compaq.com/SRC/pjb/>.
- "New & Improved: Touchpad Redux," PC Magazine, Sep. 10, 1996.
- "National Design Engineering Show Conference," Design News, Cahners Publication, issue 5, Mar. 4, 1996.
- "MultiTouch Overview," FingerWorks, Newark, NJ, retrieved from <http://www.fingerworks.com/multoverview.html> on Jan. 10, 2008.
- "The Laser Focus World Buyers Guide," Laser Focus World, Nashua, NH, PennWell Publishing Company, Dec. 1995.
- Marty Petersen, "Koalapad touch tablet & Micro Illustrator software," InfoWorld Media Group, Oct. 10, 1983.
- William Buxton, Ralph Hill and Peter Rowley, "Issues and Techniques in Touch-Sensitive Tablet Input" Computer Graphics, 19(3), Proceedings of SIGGRAPH'85, pp. 215-223, 1985.
- "Intellivision Intelligent Television Master Component Service Manual," Sylvania, Mattel, Inc., 1979.
- T.L. Petruzzellis, "Force-sensing resistors," Electronics Now, vol. 64, issue 3, p. 65, Mar. 1993.
- "Mouse Emulation," FingerWorks, Newark, NJ, retrieved from http://www.fingerworks.com/gesture_guide_mouse.html on Jan. 10, 2008.
- "Gesture Recognition," FingerWorks, Newark, NJ, retrieved from http://www.fingerworks.com/gesture_recognition.html on Jan. 10, 2008.
- "LogiCad3D Product Overview—ErgoCommander?," LogiCad3D a Logitech company, Fremont, CA, retrieved from www.logicad3d.com/products/ErgoCommander.htm on Apr. 8, 2002.
- Minoru Kobayashi "Design of dynamic soundscape: mapping time to space for audio browsing with simultaneous listening," Thesis Massachusetts Institute of Technology, 1996.
- Shinji Kobayashia and Katsumi Miyazawa, "Development of the touch switches with the click response," Koukuu Denshi Gihou No. 17: pp. 44-48, Mar. 1994.
- Minoru Kobayashi and Chris Schmandt, "Dynamic Soundscape: mapping time to space for audio browsing," Proceedings of CHI '97, Mar. 22-27, 1997.
- "Design News: Literature Plus," Design News, Cahners Publication, issue 24, Dec. 18, 1995.
- David H. Ahl "Controller Update," Creative Computing, vol. 9, No. 12, Dec. 1983.
- "Sony presents 'Choice Without Compromise' at IBC '97," M2 Presswire, M2 Communications Ltd., Jul. 24, 1997.
- C. Cohen, "A Brief Overview of Gesture Recognition," 1999 retrieved from http://homepages.inf.ed.ac.uk/rbf/CVonline/LOCAL_COPIES/COHEN/gesture_overview.htm on Jan. 10, 2008.
- "BeoConn 6000 User Guide," Bang & Olufsen, Struer, Denmark, 2000.
- "Atari VCS/2600 Peripherals," retrieved from classicgaming.com on Feb. 28, 2007.
- "Alps Electric introduces the GlidePoint Wave Keyboard; combines a gently curved design with Alps' advanced GlidePoint technology," Business Wire, Oct. 21, 1996.
- "Alps Electric Ships GlidePoint Keyboard for the Macintosh; Includes a Glidepoint Touchpad, Erase-Eaze Backspace Key and Countoured Wrist Rest," Business Wire, Jul. 1, 1996.
- Marc Spiwak, "A pair of unusual controllers," Popular Electronics, vol. 14, issue 4, Apr. 1997.
- Marc Spiwak, "A great new wireless keyboard," Popular Electronics, vol. 14, issue 12, Dec. 1997.
- Forrest Mims, "A few quick pointers; mouses, touch screens, touch pads, light pads, and the like can make your system easier to use," Computers&Electronics, v.22, p. 64, 1984.
- Brochure, "BeoCom 6000: Sales Training," Bang & Olufsen, Struer, Denmark, 2000.
- "Der Klangmeister," Connect Magazine, Aug. 1998.
- "Product Overview: iGesture Products for Everyone (learn in minutes)," FingerWorks, Newark, NJ, retrieved from <http://www.fingerworks.com/> on Aug. 30, 2005.
- "Caz Pocket Computers Collection: BellSouth -IBM Simon -PDA cellphone," retrieved from <http://cdecas.free.fr/computers/pocket/simon.php> on Nov. 21, 2008.
- "IBM Simon," Wikipedia article, retrieved from http://en.wikipedia.org/wiki/IBM_Simon last viewed on Nov. 21, 2008.
- Chris O'Malley, "BellSouth's communicative Simon is a milestone in the evolution of the PDA", Byte.com, Dec. 1994, retrieved from <http://www.byte.com/art/9412/sec11/art3.htm>.
- "IBM's plans to ship Simon put on hold for time being," Business Services Industry, Mobile Phone News, Apr. 4, 1994, retrieved from http://findarticles.com/p/articles/mi_m345.
- Amon, C.H.; Nigen, J.S.; Siewiorek, D.P.; Smailagic, A.; and Stivoric, J., "Concurrent Design and Analysis of the Navigator Wearable Computer System: The Thermal Perspective," IEEE Transactions on Components, Packaging, and Manufacturing Technology, Part A, Sep. 1995, pp. 567-577, vol. 18, No. 3.
- U.S. ITC, In the Matter of Certain Portable Electronic Devices and Related Software: Order No. 57: Construing the Terms of the Asserted Claims of the Patents at Issue, Jun. 26, 2012, pp. 63-97.
- Jun Rekimoto, "Tilting Operations for Small Screen Interfaces (Tech Note)," 1996.
- Z. Szalavari; and M. Gervautz; "The Personal Interaction Panel—A Two- Handed Interface for Augmented Reality," Computer Graphics Forum, Sep. 1997, pp. C335-C346, vol. 16, No. 3.
- Apple, Newton—Apple MessagePad Handbook, 1995, pp. 1-358.
- Newton MessagePad 2000 User's Manual, pp. 1-278 (1997).
- Kenneth P. Fishkin; Thomas P. Moran; and Beverly L. Harrison; "Embodied User Interfaces: Towards Invisible User Interfaces," Proceedings of EHCI 98, (Heraklion, Crete, Sep. 13-18, 1998).
- Steve Nasiri; Shang-Hung Lin; Davids Sachs; and Joseph Jiang; "Motion Processing: The Next Breakthrough Function in Handsets," Mobile Dev&Design, 2010, pp. 1-10.
- Lynellen D.S. Perry; Christopher M. Smith; and Steven Yang; "An Investigation of Current Virtual Reality Interfaces," Crossroads The ACM Student Magazine, Mar. 1992.

(56)

References Cited

OTHER PUBLICATIONS

- G.W. Fitzmaurice, "Situated Information Spaces and Spatially Aware Palmtop Computers," *Communications of the ACM*, Jul. 1993, pp. 39-49, vol. 36, No. 7.
- R. Azuma; and G. Bishop; "Improving Static and Dynamic Registration in an Optical See-through HMD," *SIGGRAPH 94*, Jul. 24-29, 1994, Orlando, Florida.
- E. Foxlin; M. Harrington; and G. Pfeifer; "Constellation: A Wide-Range Wireless Motion-Tracking System for Augmented Reality and Virtual Set Applications," *Proceedings of SIGGRAPH 98*, Jul. 19-24, 1998, Orlando, Florida.
- T.W. Bleser; J.L. Sibert; and J.P. McGee, "Charcoal Sketching: Returning Control to the Artist," *The Interaction Technique Notebook*, 1988.
- D. Small; and H. Ishii, "Design of Spatially Aware Graspable Displays," *CHI 97*, Mar. 22-27, 1997, pp. 367-368.
- M.A. Viredaz, WRL Technical Note TN-54—The Memory Daughter-Card Version 1.5 User's Manual, Jul. 1998.
- M.A. Viredaz, WRL Technical Note TN-55—The Itsy Pocket Computer Version 1.5 User's Manual, Jul. 1998.
- Bartlett et al., WRL Research Report 2000/6—The Itsy Pocket Computer, Oct. 2000.
- K. Kawachiya and H. Ishikawa, "NaviPoint: An Input Device for Mobile Information Browsing," *CHI '98*, Apr. 18-23, 1998.
- G. Levin; and P. Yarin, "Bringing Sketching Tools to Keychain Computers with an Acceleration-Based Interface," *Proceedings of CHI1998 Extended Abstracts*, ACM, New York, 1998, pp. 268-269.
- A. Schmidt; M. Beigl; and H.W. Gellerson; "There is More to Context than Location," 1998.
- Want et al., "An Overview of the PARCTAB Ubiquitous Computing Experiment," *IEEE Personal Communications*, Dec. 1995, pp. 28-43.
- di Massimo Truscelli, "Radius Full Page Pivot," *MCmicrocomputer*, Apr. 1992, No. 117, pp. 136-140.
- G.W. Fitzmaurice; S. Zhai; and M.H. Chignell, "Virtual Reality for Palmtop Computers," *ACM Transactions on Information Systems*, Jul. 1993, pp. 197-218, vol. 11, No. 3.
- Order No. 58: Initial Determination Granting Motion to Terminate Investigation with Respect to Certain Claims; ITC Inv. No. 337-TA-797.
- W.A. Hoff; K. Nguyen; and T. Lyon, "Computer Vision-Based Registration Techniques for Augmented Reality," 1996.
- J. Woodfill and B. Von Herzen, "Real-Time Stereo Vision on the PARTS Reconfigurable Computer," 1997.
- R. Holloway and A. Lastra; "Virtual Environments: A Survey of the Technology," 1993.
- A.L. Zwern and G.L. Goodrich, "Virtual Computer Monitor for Visually-Impaired Users," 1996.
- G.F. Welch, "Hybrid Self-Tracker: An Inertial/Optical Hybrid Three-Dimensional Tracking System," 1995.
- Geoff Walker, "Touch screen highlights from the SID 2006 show floor," Jun. 2006, pp. 19-26.
- Geoff Walker, "A Cornucopia of Touch Technology," 2006.
- G.L. Barret, "Filters and Other Touch Screen Enhancements," *iTouch International*, pp. 1-8.
- "Noise Frequencies in Capacitive Touch Screens," *IBM Retail Store Solutions*, pp. 1-8.
- J.F. Bartlett, "Rock 'n' Scroll is here to stay [user interface]," *Computer Graphics and Applications*, IEEE, May/June. 2000, vol. 20, Issue 3.
- B.L. Harrison; K.P. Fishkin; A. Gujar; C. Mochon; and R. Want, "Squeeze Me, Hold Me, Tilt Me! An Exploration of Manipulative User Interfaces," *CHI '98*, Los Angeles, CA USA, Apr. 1998, pp. 17-24.
- G. Kurtenbach; G. Fitzmaurice; T. Baudel; and B. Buxton, "The Design of a GUI Paradigm based on Tablets, Two-hands, and Transparency," *CHI '97*, Mar. 22-27, 1997.
- C. Kitchin, *Using Accelerometers in Low g Applications*, Analogue Devices Application Note AN-374, 1995.
- E. Foxlin and N. Durlach, *An Inertial Head-Orientation Tracker With Automatic Drift Compensation for Use With HMDs*, VRST 94, Singapore, Aug. 23-26, 1994.
- B. MacIntyre and S. Feiner, *Future Multimedia User Interfaces*, 1996.
- Krueger, *Videoplace—An Artificial Reality*, *CHI '85 Proceedings of the SIGCHI conference on Human factors in computing systems*, pp. 35-40.
- Rubine, "Automatic Recognition of Gestures" pp. 1-266.
- Westerman, "Hand Tracking, Finger Identification, and Chordic Manipulation on a Multi-Touch Surface" pp. 1-333.
- Verplaetse, "Inertial Proprioceptive Devices—Self-Motion-Sensing Toys and Tools," *IBM Systems Journal*, 1996, pp. 639-650, vol. 35, Nos. 3 & 4, C.
- I. Sutherland, "A Head Mounted Three Dimensional Display," *proceedings FJCC 1968*.
- J. H. Bohn, "Computer Aided Design I," 1997.
- "Frontiers of Engineering, Reports on Leading Edge Engineering from the 1996 NAE Symposium on Frontiers of Engineering," 1997.
- Helms et al., "Virtual Environment Technology for MOUT Training," 1997.
- G.A. Henault, "A Computer Simulation Study and Component Evaluation for a Quaternion Filter for Sourceless Tracking of Human Limb Segment Motion," 1997.
- "Advanced Technology for Portable Personal Visualization," 1992.
- J.D. Foley; A. Van Dam; and S.K. Feiner, "Computer Graphics Principles and Practice," 1995.
- "Kitchen Computer IBM Technical Disclosure Bulletin," 1994, pp. 223-225, vol. 37, No. 12.
- J.H. Bohn, *Computer-Aided Design I—Term Papers*, 1997.
- "Image Orientation Sensing and Correction for Notepads," *Research Disclosure No. 34788*, 1993, p. 217.
- Analog Devices, Inc., *Analog Devices—Programmable Capacitance-to-Digital Converter with Environmental Compensation*, 2005.
- Meyer, H.U.; Sylvac SA, Crissier; "An Integrated Capacitive Position Sensor," *Instrumentation and Measurement Technology Conference, IMTC/95.Proceedings. 'Integrating Intelligent Instrumentation and Control'*, IEEE, 1995.
- D. Strickland; A. Patel; C. Stovall; J. Palmer; and D. McCalister, *Self Tracking of Human Motion for Virtual Reality Systems*, 1994, pp. 8-10.
- Computer Graphics Forum*, 1995, pp. 29-41, vol. 14, Issue 3.
- P.A. Millman; M. Stanley; and J.E. Colgate, *Design of a High Performance Haptic Interface to Virtual Environments*, *Virtual Reality Annual International Symposium*, 1993.
- D. Kim; S.W. Richards; and T.P. Caudell, *An Optical Tracker for Augmented Reality*, *Virtual Reality Annual International Symposium*, 1997.
- Second Annual Symposium on the Frontiers of Engineering*, National Academies Press 1997.
- M. Kruger, *Addition of Olfactory Stimuli to Virtual Reality Simulations for Medical Training Application*, 1996.
- T. Higgins; P. Main; and J. Lang, *Imaging the Past: Electronic Imaging and Computer Graphics in Museums and Archaeology*, 1997.
- Proceedings on the First International Symposium of Wearable Computers*, IEEE, 1997.
- M.W. Kruger, *Artificial Reality*, 1983.
- M.W. Kruger, *Artificial Reality II*, 1991.
- L. Borman and B. Curtis, *Human Factors in Computing Systems*, *CHI '85 Conference Proceedings*, Apr. 14-18, 1985, San Francisco.
- James D. Foley et al., *Computer Graphics—Principles and Practice*, 2nd Edition, 1990.
- James D. Foley et al., *Computer Graphics—Principles and Practice*, 2nd Edition, 1996.
- R.M. Baecker; W.A.S. Buxton; J. Grudin and S. Greenberg, *Readings in Human-Computer Interaction: Toward the Year 2000*, 1995.
- J.D. Foley et al., *Introduction to Computer Graphics*, 1994.
- J. Zukowski, *Java AWT Reference (Java 1.1)*, 1997.
- B. Laurel, *The Art of Human-Computer Interface Design*, 1990.
- D.A. Norman and S.W. Draper, *User Centered System Design*, 1986.
- Analog Devices, *ADXL05 Data Sheet*, 1996.
- Anthony Lawrence, "Modern Inertial Technology," *Springer-Verlag*, New York, 1993.

(56)

References Cited

OTHER PUBLICATIONS

- Teresa Anne Marin, *Toward an Understanding of Musical Gesture: Mapping Expressive Intention with the Digital Baton*, MIT Masters Thesis, Jun. 1996.
- C.J. Verplaestse, *Inertial-Optical Motion-Estimating Camera for Electric Cinematography*, MIT Masters Thesis, Jun. 1997.
- PenPoint API Reference, vols. 1 & 2, Addison-Wesley, 1992.
- PenPoint Architectural Reference, vols. 1 & 2, Addison-Wesley, 1992.
- Robert Carr and Dan Shafer, "The Power of PenPoint," Addison-Wesley, 1991.
- Eric Azinger, "Radius Display Can Fit Different Orientations," *InfoWorld*, Jul. 22, 1991, p. 69, vol. 13, No. 29.
- "IBM Technical Disclosure Bulletin, vol. 36 No. 1, Jan. 1, 1993, p. 414 "Reminder Pen".
- Order No. 58: Initial Determination Granting Motion to Terminate Investigation with Respect to Certain Claims; ITC Inv. No. 337-TA-797, Jun. 26, 2012.
- G.L. Barret, "Filters and Other Touch Screen Enhancements," *iTouch International*, pp. 1-8, Archived by archive.org on Nov. 22, 2006, <http://web.archive.org/web/20061122003733/http://www.touchinternational.com/literature/whitepapers/filtersandothertouchscreenenhancements.pdf> (Available online at <http://touchinternational.com/literature/whitepapers/FiltersandOtherTouchScreenEnhancements.pdf>, last visited Mar. 13, 2013).
- "Noise Frequencies in Capacitive Touch Screens," IBM Retail Store Solutions, pp. 1-8, PDF document created Jul. 26, 2004. (Available online at <https://www-304.ibm.com/support/docview.wss?uid=pos1R1003106&aid=1>, last visited Mar. 13, 2014).
- Krueger, *Videoplacement—An Artificial Reality*, CHI '85 Proceedings of the SIGCHI conference on Human factors in computing systems, ACM, vol. 16, Issue 4, Apr. 1985, pp. 35-40.
- Rubine, "Automatic Recognition of Gestures," Doctoral Dissertation, Carnegie Mellon University, Pittsburgh, PA, Dec. 1991, pp. 1-266.
- Westerman, "Hand Tracking, Finger Identification, and Chordic Manipulation on a Multi-Touch Surface," PhD thesis, University of Delaware, Spring 1999, pp. 1-333.
- Jenifer Tidwell, "Designing Interfaces: Patterns for Effective Interaction Design," O'Reilly Media, Inc., Sebastopol, CA, USA, First Edition, Nov. 2005.
- R.M. Baecker and W.A.S. Buxton, *Readings in Human-Computer Interaction: A Multidisciplinary Approach*, Morgan Kaufmann Publishers Inc, Los Altos, CA, 1987.
- IBM Technical Disclosure Bulletin, "Personal Computer Environmental Control Via a Proximity Sensor," Aug. 1993, US.
- Hilary Lyndsay Williams, "Multi-Functional Cellular Telephone", U.S. Appl. No. 13/188,239, filed Jul. 21, 2011.
- Office Action dated Feb. 4, 2011 in co-pending Reissue U.S. Appl. No. 12/255,557, filed Oct. 21, 2008.
- Aboelsaadat et al., "An Empirical Comparison of Transparency on One and Two Layer Displays," *People and Computers XVIII: Proceedings of the British HCI Conference*, pp. 1-20, 2004.
- Ahmad, "A Usable Real-Time 3D Hand Tracker," in *Proceedings 28th Asilomar Conference on Signals, Systems and Computers*, Interval Research Corporation, vol. 2, pp. 1257-1261, Palo Alto, CA, 1995, 5 pages.
- Author Unknown, "Chart of Spatial Keyframing, Traditional Interfaces, interface Techniques, 3D Control and Visulation and Ongoing Work," 1 page, 2007.
- Author Unknown, "Error and Coupling: Extending Common Ground to Improve the Provision of Visual Information for Collaborative Tasks," *Proceedings from the Conference of the International Communication Association*, pp. 1-35, 2008.
- Baecker et al., "The University of Toronto Dynamic Graphics Project," *Computer Systems Research Institute, University of Toronto, Proceedings of the ACM CHI '91 Human Factors in Computing Systems Conference*, pp. 467-468, 1991, 2 pages.
- Barret et al., "Filters and Other Touch Screen Enhancements," 8 pages *iTouchInternational*, Dec. 2, 2011.
- Bederson et al., "Jazz: An Extensible Zoomable User Interface Graphics Toolkit in Java," *Proceedings of the 13th Annual ACM Symposium on User Interface Software and Technology*, Nov. 6-8, 2000, ACM Press, 11 pages.
- Birnholtz et al., "Using Motion Tracking Data to Augment Video Recordings in Experimental Social Science Research," *Third International Conference on E-Social Science*, Oct. 7-9, 2007, Ann Arbor, Michigan, 10 pgs.
- Browne et al., "Designing a Collaborative Finger Painting Application for Children," CS-TR-4184, Human-Computer Interaction Lab, University of Maryland, College Park, MD, Oct. 6, 2000, 8 pages.
- Buxton et al., "A Microcomputer-based Conducting System," 14 pages, *Structured Sound Synthesis Project, Computer Systems Research Group, University of Toronto, Toronto, Ontario, CA, Computer Music Journal*, 4(1):8-21, Spring 1980.
- Buxton et al., "The Use of Hierarchy and Instance in a Data Structure for Computer Music," *Computer Music Journal*, vol. II, No. 4, pp. 10-20, Dec. 1978, 11 pages.
- Buxton et al., "An introduction to the SSSP Digital Synthesizer," 11 pages, vol. II, No. 4, pp. 28-38, *Computer Music Journal*, Menlo Park, CA, Dec. 1978.
- Cao et al., "Evaluation of an On-line Adaptive Gesture Interface with Command Prediction," *Proceedings of Graphics Interface*, pp. 187-194, 8 pages, University of Toronto, 2005.
- Carpendale, "Roles of Orientation in Tabletop Collaboration: Comprehension, Coordination and Communication," *Computer Supported Cooperative Work (CSCW)*, University of Calgary, Alberta, Canada, Dec. 2004, 33 pages.
- CENA, "DigiStrips humaniser les interfaces," 1 page, Toulouse, France, 2001.
- Dietz et al., "Submerging Technologies," 1 page, *Proceeding ACM SIGGRAPH 2006, Emerging Technologies Article No. 30*, Mitsubishi Electric Research Labs, 2006.
- DSNA, "Activity related to VIGIESTRIPS: study of a support of flight plan information devised for the benefit of the Watchtower," 2011, 4 pages, [mhtml:file://S:\DFSR_DATA/Data01\051900\Prior Art\915\00—Michael Kobayashi\10.1...](mhtml:file://S:\DFSR_DATA\Data01\051900\Prior Art\915\00—Michael Kobayashi\10.1...), Accessed Oct. 12, 2011.
- DSNA, "Vigiestrips Making Strips a part of A-SMGCS," 14 pages, CENA, 2004.
- Esteban et al., "Visual construction of highly interactive applications," *Visual Database Systems 3, IFIP—The International Federation for Information Processing*, pp. 304-316, CENA/PII/95.641/O Version 1, 15 pages, 1995.
- Fedorkow et al., "A Computer-Controlled Sound Distribution System for the Performance of Electroacoustic Music," *Computer Music Journal*, vol. II, No. 3, pp. 33-42, 10 pages, Dec. 1978.
- Fryberger et al., "An Innovation in Control Panels for Large Computer Control Systems," *4th IEEE Particle Accelerator Conference*, Chicago, IL, Mar. 1-3, 1971, pp. 414-417, 4 pages.
- Fukuchi et al., "Interaction Techniques for SmartSkin," *Proceedings of UIST*, 2 pages, 2002.
- Fukuchi et al., "Marble Market: Bimanual Interactive Game with a Body Shape Sensor," *Entertainment Computing—ICEC 2007, Lecture Notes in Computer Science*, 4740:374-380, 8 pgs. 2007.
- Fukuchi et al., "SmartSkin," *Proceedings of Entertainment Computing 2003, IPSJ Symposium Series vol. 2003, No. 1*, pp. 70-74—(Only summary in English), 5 pages, 2003.
- Fukuchi, "Multi-Track Scratch Player on a Multi-Touch Sensing Device," *Entertainment Computing—ICEC 2007, Lecture Notes in Computer Science*, 4740:211-218, 8 pgs, 2007.
- Gross, "Grids in Design and CAD," *Reality and Virtual Reality: Mission-Method-Madness: ACADIA Conference Proceedings*, pp. 33-43, ACADIA, Los Angeles, California, 11 pages, 1991.
- Gujar et al., "Talking Your Way Around a Conference: A speech interface for remote equipment control," *CASCON '95 Proceedings of the 1995 Conference of the Centre for Advanced Studies on Collaborative Research*, p. 26, 7 pages, University of Toronto, Toronto, Ontario, Canada, 1995.
- Han et al., "Multi-Touch Interaction Research Animation Theater," *Computer Animation Festival, Electronic Art and Animation Catalogue*, pp. 244, 1 page, New York University, 2006.

(56)

References Cited

OTHER PUBLICATIONS

- Han, "Media Mirror," SIGGRAPH '05 Sketches, Article No. 4, 1 page, Media Research Laboratory, New York University, 2005.
- Han, "Multi-Touch Interaction Wall," SIGGRAPH '06, Emerging Technologies, Article 25, 1 page, Courant Institute of Mathematical Sciences, New York University, Aug. 2006.
- Han, "Multi-Touch Sensing through Frustrated Total Internal Reflection," 1 page, Media Research Laboratory, New York University, 2005.
- Herot et al., "One-Point Touch Input of Vector Information for Computer Displays," SIGGRAPH '78 Proceedings of the 5th Annual Conference on Computer Graphics and Interactive Techniques, ACM, pp. 210-216, 7 pages, 1978.
- Hinrichs et al., "Interface Currents: Supporting Fluent Collaboration on Tabletop Displays," Smart Graphics, Lecture Notes, Computer Science, 3638:185-197, 12 pages, Otto-von-Guericke University, Magdeburg, Germany, 2005.
- HTC, "Touch Pro," Quick Start Guide, 41 pages, 2008.
- HTC, "Your HTC 7 Pro," Quick Guide, 2 pages, 2011.
- HTC, "Your HTC 7 Trophy," Quick Guide, 2 pages, 2010.
- HTC, "Your HTC Radar 4G," Quick Guide, 2 pages, 2011.
- HTC, "Your HTC Sensation 4G," User Guide, 191 pages, 2011.
- HTC, "Your HTC Wildfire S," Quick Guide, 2 pages, 2011.
- Hudson et al., "Animation Support in a User Interface Toolkit: Flexible, Robust, and Reusable Abstractions," Proceedings of the ACM Symposium on User Interface Software and Technology, pp. 57-67, Graphics Visualization and Usability Center, College of Computing, 10 pages, Georgia Institute of Technology, Atlanta, GA, 1993.
- IBM Retail Store Solutions, "Noise Frequencies in Capacitive Touch Screens," 8 pages, 2004.
- Integrated—Google Search, Dictionary "in-te-grat-ed," 2 pages <https://www.google.com/search?source=jg&hl=en&rlz-&q=define+integr...>, Accessed Mar. 21, 2012.
- Internet.com, "Flash Kit," A Flash Developer Resource Site, 3 pages, Aug. 28, 2005.
- Karlson et al., "AppLens and LaunchTile: Two Designs for One-Handed Thumb Use on Small Devices," Human-Computer Interaction Lab, University of Maryland, Proceedings of the SIG CHI Conference on Human Factors in Computing Systems, 2005, 10 pages.
- Keskin et al., "Real Time Hand Tracking And 3D Gesture Recognition For Interactive Interfaces Using HMM," 4 pages, Computer Engineering Dept. Bogazici University, 2003.
- Kitchin, "Using Accelerometers in Low g Applications," 6 pages, Analog Devices, Norwood, MA, 1995.
- Kruger, et al., "How People Use Orientation on Tables: Comprehension, Coordination and Communication," Group '03 Proceedings of the 2003 International ACM SIGGROUP Conference on Supporting Group Work, pp. 369-378, 10 pages, Univ. of Calgary, Department of Science, Calgary, Alberta, 2003.
- Levin et al., "Bringing Sketching Tools to Keychain Computers with an Acceleration-Based Interface," CHI EA '99 CHI '99 Extended Abstracts on Human Factors in Computing Systems, ACM, 2 pages, MIT Media Laboratory, Cambridge, MA, 1999.
- Mackay et al., "Reinventing the Familiar: Exploring an Augmented Reality Design Space for Air Traffic Control," CHI '98 Proceedings of the SIGCHI Conference on Human Factors in Computing Systems, ACM Press/Addison-Wesley Publishing Co., 8 pages, 1998.
- McGuffin et al., "Expand-Ahead: A Space-Filling Strategy for Browsing Trees," IEEE Symposium on Information Visualization, 8 pages, University of Toronto, 2004.
- McGuffin et al., "Interactive Visualization of Genealogical Graphs," IEEE Symposium on Information Visualization, Oct. 23-25, 2005, 8 pages.
- Moscovich et al., "A Multi-finger Interface for Performance Animation of Deformable Drawings," Demonstration at UIST 2005 Symposium on User Interface Software and Technology, Seattle, Washington, Oct. 2005, 2 pages.
- Moscovich et al., "Multi-finger Cursor Techniques," Proceedings of Graphics Interface 2006, Quebec City, Canada, Jun. 2006, 7 pages, Department of Computer Science, Providence, RI, 2006.
- Narayanaswamy et al., "User Interface for a PCS Smart Phone," IEEE International Conference on Multimedia Computing and Systems, vol. 1, 1999, 5 pages.
- Nasiri et al., "Motion Processing: The Next Breakthrough Function in Handsets," 10 pages, InvenSense, Inc., Sunnyvale, CA, 2010.
- Oka et al., "Real-time Tracking of Multiple Fingertips and Gesture Recognition for Augmented Desk Interface Systems," Proceedings of Fifth IEEE International Conference on Automated Face and Gesture Recognition, May 20-21, 2002, 6 pages, Institute of Industrial Science, University of Tokyo, Tokyo, Japan.
- Owen et al., "When It Gets More Difficult, Use Both Hands- Exploring Bimanual Curve Manipulation," Proceedings of Graphics Interface 2005, pp. 17-24, Canadian Human-Computer Communications Society, 8 pages, Alias, Toronto, Ontario, Canada, 2005.
- Perlin et al., "PAD: An Alternative Approach to the Computer Interface," Proceedings of the 20th Annual Conference on Computer Graphics and Interactive Techniques, pp. 57-64, Courant Institute of Mathematical Sciences, NYU, pp. 1-11, New York, NY, 1993.
- Perry et al., "An investigation of Current Virtual Reality Interfaces," 17 pages, Crossroads 3(3):23-28, The ACM Student Magazine, Mar. 1997.
- Railane et al., "Tackling the Problem of Flight Integration," 10 pages, Toulouse, France, 2007.
- Reetz et al., "Superflick: a Natural and Efficient Technique for Long-Distance Object Placement on Digital Tables," Proceedings of Graphics Interface 2006, pp. 163-170, Canadian Information Processing Society, 8 pages, University of Saskatchewan, Saskatoon, Canada, Jul. 6, 2006.
- Rekimoto et al., "Augmented Surfaces: A Spatially Continuous Work Space for Hybrid Computing Environments," Proceedings of the SIG CHI Conference on Human Factors in Computing Systems, pp. 378-385, 8 pages, 1999.
- Rekimoto, "Tilting Operations for Small Screen Interfaces," Proceedings of the 9th Annual ACM Symposium on User Interface Software and Technology, pp. 167-168, 2 pages, Sony Computer Science Laboratory, inc., Tokyo, Japan, 1996.
- Rosenberg et al., "Real-Time Stereo Vision using Semi-Global Matching on Programmable Graphics Hardware," ACM SIGGRAPH 2006 Sketches, p. 89, 1 page, New York University, Jul. 30, 2006.
- Salaun et al., "Innovative HMI for the busiest airport towers," Air Traffic Technology International 2006, pp. 92-95, 4 pages, 2006.
- Schmidt et al., "There is more to Context than Location," Computer and Graphics, 23(6):893-901, 10 pages, University of Karlsruhe, Karlsruhe, Germany, Dec. 1999.
- Shapetape, "9 Photographic Illustrations," Proceedings of 1999 ACM Symposium on Interactive 3D Graphics (I3DG'99), 1999, 1 page.
- Singh et al., "Numeric Paper Forms for NGOs," in International Conference on Information and Communication Technologies and Development (ICTD), IEEE, pp. 1-11, 2009.
- Smith et al., "Croquet: A Menagerie of New User Interfaces," Proceedings of Second International Conference on Creating, Connecting, and Collaborating through Computing, 2004, pp. 4-11, 8 pages.
- TMobile, "HTC Sensation 4G," Start Guide, 21 pages, 2011.
- Toccatà, "Demonstrating Interaction Techniques for an ATC Workstation," 1 page, CENA, Toulouse, France, 2001.
- Tsang et al., "Boom Chameleon: Simultaneous capture of 3D viewpoint, voice and gesture annotations on a spatially-aware display," Proceedings of the 15th Annual ACM Symposium on User Interface Software and Technology, pp. 111-120, 10 pages, Toronto, Canada, 2002.
- Tsang et al., "Temporal Thumbnails: Rapid Visualization of Time-Based Viewing Data," Proceedings of the Working Conference on Advanced Visual Interfaces, 'ages 175-178, 8 pages, University of Toronto, 2004.
- Verizon, "HTC Rhyme," Getting Started Guide. 66 pages, 2011.
- Virgin Mobile, "HTC Wildfire S," User Manual, 172 pages, 2011.
- Wallace, "The Semantics of Graphic Input Devices," ACM SIGPLAN Notices 11, No. 6, pp. 61-65, 5 pages, University of North Carolina, Chapel Hill, NC, 1976.
- Welch, "Hybrid Self-Tracker: An Inertial/Optical Hybrid Three-Dimensional Tracking System," 21 pages, Technical Report TR 95-048, University of North Carolina Chapel Hill, Chapel Hill, NC, 1995.

(56)

References Cited

OTHER PUBLICATIONS

Wigdor et al., "Empirical Investigation into the Effect of Orientation on Text Readability in Tabletop Displays," ECSCW 2005, pp. 205-224, Springer Netherlands, 21 pages, 2005.

Wigdor et al., "Table-Centric Interactive Spaces for Real-Time Collaboration," images, 1 pg., Mitsubishi Electric Research Laboratories, Proceedings of the Working Conference on Advanced Visual Interfaces, ACM, May 1, 2006.

Wigdor et al., "Table-Centric Interactive Spaces for Real-Time Collaboration: Solutions, Evaluation, and Application Scenarios," Proceedings of the Working Conference on Advanced Visual Interfaces, ACM 2006, 6 pgs.

Wilson et al., "FlowMouse: A Computer Vision-Based Pointing and Gesture Input Device," Human-Computer Interaction-INTERACT 2005, pp. 565-578, Springer, Berlin, 14 pages, Microsoft Research, Redmond, WA, 2005.

Ahl, "Controller Update," Creative Computing, vol. 9, No. 12, Dec. 1983, 6 pages.

Author Unknown, "Alps Electric Introduces the GlidePoint Wave Keyboard; Combines a Gently Curved Design with Alps' Advanced GlidePoint Technology," Business Wire, Oct. 21, 1996, 3 pages, <http://www.encyclopedia.com/printable.aspx?id=1G1:18786732> accessed Jun. 6, 2007.

Author Unknown, "Alps Electric Ships GlidePoint Keyboard for the Macintosh; Includes a Glidepoint Touchpad, Erase-Eaze Backspace Key and Contoured Wrist Rest," Business Wire, Jul. 1, 1996, 2 pages.

Author Unknown, "Atari VCS/2600 Peripherals," retrieved from [classicgaming.com](http://www.classicgaming.com/gamingmuseum/2600p.html) on Feb. 28, 2007, 15 pages, <http://www.classicgaming.com/gamingmuseum/2600p.html> accessed Feb. 28, 2007.

Author Unknown, "BeoCom 6000 User Guide," Bang & Olufsen, Struer, Denmark, 2000, 53 pages.

Author Unknown, "BeoCom 6000: Sales Training," Brochure, Bang & Olufsen, Struer, Denmark 2000, 5 pages.

Author Unknown, "Der Klangmeister," Connect Magazine, Aug. 1998, 6 pages, German with English Translation.

Author Unknown, "Design News: Literature Plus," Design News, Cahners Publication, Issue 24, Dec. 18, 1995, 30 pages.

Author Unknown, "Design News: Product News," Cahners Publication, Issue No. 11, Jun. 9, 1997, 34 pages.

Author Unknown, "Design News: Product News," Cahners Publication, Issue No. 9, May 5, 1997, 56 pages.

Author Unknown, "Design News: National Design Engineering Show Conference, Mar. 18-21, 1996, McCormick Place, Chicago," Cahners Publication, Issue No. 5, Mar. 4, 1996, 87 pages.

Author Unknown, "IBM's Plans to Ship Simon Put on Hold for Time Being," Business Services Industry, Mobile Phone News, Apr. 4, 1994, 5 pages, retrieved from http://findarticles.com/p/articles/mi_m3457/is_n14_v12/ai_14973288, on Nov. 21, 2008.

Author Unknown, "JavaScript Language Reference," retrieved from [http://msdn.microsoft.com/en-us/library/ie/dlet7k7c\(v=vs.94\).aspx](http://msdn.microsoft.com/en-us/library/ie/dlet7k7c(v=vs.94).aspx) on Jun. 3, 2013, 1 page.

Author Unknown, "LogiCad3D Product Overview—ErgoCommander?," LogiCad3D a Logitech Company, Fremont, CA, retrieved from www.logicad3d.com/products/ErgoCommander.html on Apr. 8, 2002, 2 pages.

Author Unknown, "Personal Jukebox (PJB): Systems Research Center and PAAD," Compaq Computer Corp., Oct. 13, 2000, retrieved from <http://research.compaq.com/SRC/pjb>, 28 pages.

Author Unknown, Press Release—LG and Prada Partner to Develop Iconic Mobile Phone, Dec. 11, 2006, 1 page, retrieved from <http://www.lg.com/us/press-release/lg-and-prada-partner-to-develop-iconic-mobile-phone> on Jul. 18, 2013.

Author Unknown, "Press Release—Novell Raises the Bar for the Linux Desktop," retrieved from <http://www.novell.com/news/press/2006/2/novell-raises-the-bar-for-the-linux-desktop> on Jul. 18, 2013, 2 pages.

Author Unknown, "Press Release—Novell Ships Desktop Linux for the Enterprise," retrieved from <http://www.novell.com/news/press/2004/11/novell-ships-desktop-linux-for-the-enterprise> on Jul. 18, 2013, 3 pages.

Author Unknown, "Sony Presents 'Choice Without Compromise' at IBC '97," M2 Presswire, M2 Communications Ltd., Jul. 24, 1997, 3 pages.

Author Unknown, "The Laser Focus World Buyers Guide," Laser Focus World, Nashua, NH, PennWell Publishing Company, Dec. 1995, 162 pages.

Author Unknown, "The News, Preview of Exhibitor Booths at the Philadelphia Show," The Air Conditioning, Heating and Refrigeration News, Business News Publishing Co., Jan. 13, 1997, 22 pages.

Bellsouth, "Caz Pocket Computers Collection: BellSouth—IBM Simon—PDA cellphone," retrieved from <http://cdecas.free.fr/computers/pocket/simon.php> on Nov. 21, 2008, 2 pages.

Author Unknown, website of DiamondTouch by Circle Twelve Inc., retrieved from <http://www.circletwelve.com/company.html> on Jul. 22, 2013, 1 page.

Buxton, "Multi-Touch Systems that I Have Known and Loved," Microsoft Research, Original Jan. 2007, Version: Mar. 19, 2003, 23 pages, <http://www.billbuxton.com/multitouchOverview.html>, retrieved May 31, 2013.

Buxton, "New Screens to forget the past forms PC and TV are in a highway . . .," retrieved from <http://www.billbuxton.com/laRecherche.html>, Sep. 14, 2011; with Google Translation retrieved Jun. 3, 2013, 15 pages.

Chang et al., "Animation: From Cartoons to the User Interface," ACM, Nov. 3-5, 1993, UIST'93, 11 pages.

Cohen "A Brief Overview of Gesture Recognition," 1999, retrieved from http://homepages.inf.ed.ac.uk/rbf/Cvonline/LOCAL_COP-IES/COHEN/gesture_overview.htm on Jan. 10, 2008, 14 pages.

Colbert, "Why the iPad will fail to win significant market share," TechRepublic Out Loud, 2010, 2 pages, <http://www.techrepublic.com/blog/tr-out-loud/why-the-ipad-will-fail-to-...>

Dewid, "Scroll Control Box," IBM Technical Disclosure Bulletin, vol. 36, No. 4, Apr. 1993, 7 pages.

Dietz et al., "DiamondTouch: A MultiUser Touch Technology," Proceedings of the UIST 2001, the 14th Annual ACM symposium on User Interface Software and Technology, Nov. 11-14, 2001, Orlando, FL USA, pp. 219-226.

Esenther et al., "Multi-User Multi-Touch Games on DiamondTouch with the DTFlash Toolkit," Dec. 2005, Mitsubishi Electric Research Laboratories, <http://www.merl.com>, 6 pages.

Evans, et al., "Tablet-Based Valuers that Provide One, Two, or Three Degrees of Freedom," Computer Graphics, vol. 15, No. 3, Aug. 1981, 7 pages.

File History, U.S. Appl. No. 09/171,921, entitled Portable Computers, which was issued as U.S. Patent No. 6,956,564 was filed Oct. 29, 1998, 574 pages.

File History, U.S. Appl. No. 12/255,557, entitled Portable Computers, which is pending was filed Oct. 21, 2008, 517 pages.

File History, U.S. Appl. No. 12/268,254, entitled Portable Computers, which was issued as U.S. Patent No. RE 44103 was filed on Nov. 10, 2008, 444 pages.

File History, U.S. Appl. No. 12/268,336, entitled Portable Computers, which is pending was filed on Nov. 10, 2008, 534 pages.

File History, U.S. Appl. No. 13/188,239, entitled Portable Computers, which is allowed was filed on Jul. 21, 2011, 215 pages.

Fingerworks, "Gesture Recognition," retrieved from http://www.fingerworks.com/gesture_recognition.html on Jan. 10, 2008, 1 page.

Fingerworks, "Mouse Emulation," retrieved from http://www.fingerworks.com/gesture_guide_mouse.html on Feb. 15, 2009, 1 page.

Fingerworks, "MultiTouch Overview," retrieved from <http://www.fingerworks.com/multioverview.html>, Jan. 10, 2008, 1 page.

Fingerworks, "Product Overview: iGesture Products for Everyone (learn in minutes)," retrieved from <http://www.fingerworks.com>, Aug. 30, 2005, 6 pages.

Fingerworks, "Tips for Typing," retrieved from http://www.fingerworks.com/mini_typing.html on Jan. 10, 2008, 2 pages.

Fingerworks, Zero-Force Ergonomic Keyboards with Touchpad Hand Gestures by FingerWorks, retrieved from <http://www.dustyneuron.com/fingerworks/>, on Jun. 3, 2013, 1 page.

Google Earth, "Navigating in Google Earth—Earth Help," retrieved from <https://support.google.com/earth/answer/148186?hl=en> on Jul. 18, 2013, 2 pages.

(56)

References Cited

OTHER PUBLICATIONS

- Grossman, "Apple's New Calling: The iPhone," Time, Jan. 10, 2007, 5 pages, <http://www.time.com/time/printout/0,8816,1575743,00.html>.
- Grossman, "Invention Of the Year: The iPhone," Time, Nov. 1, 2007, 2 pages, http://www.time.com/time/specials/2007/printout/0,29239,1677329_1678542_1677891,00...
- Headrush, "Creating Passionate Users: iPhone and the Dog Ears User Experience Model," 2007, 11 pages, http://headrush.typepad.com/creating_passionate_users/2001/01/iphone_and_the_.html.
- Hilbert et al., "Extracting Usability Information From User Interface Events," ACM Computing Surveys, 2000, pp. 384-421, vol. 32, No. 4, ACM, New York.
- IBM, "Image Orientation Sensing and Correction for Notepads," Mar. 19, 2005, ip.com, PriorArtDatabase, Mar. 1, 1993, 2 pages.
- IBM, "Kitchen Computer," IBM Technical Disclosure Bulletin, vol. 37, No. 12, Dec. 1994, 5 pages.
- IBM, "Personal Computer Environmental Control Via a Proximity Sensor," vol. 36, No. 8, pp. 343-346, Aug. 1, 1993, IBM Technical Disclosure Bulletin.
- IBM, "Reminder Pen," IBM Technical Disclosure Bulletin, vol. 36, No. 1, Jan., 1993, 1 page.
- Innovation Zen, "10 Reasons Why the iPhone Might Flop," 2007, 6 pages, <http://innovationzen.com/blog/2007/01/18/10-reasons-why-the-iphone-might-flop/>, retrieved Jul. 23, 2013.
- Kim et al., "An Optical Tracker for Augmented Reality and Wearable Computers," IEEE 1997, Proceedings of the 1997 Virtual Reality Annual International Symposium, 5 pages.
- Kobayashi et al., "Development of the Touch Switches with the Click Response," Koukuu Denshi Gihou No. 17, Mar. 1994, 10 pages.
- Kobayashi et al., "Dynamic Soundscape: Mapping Time to Space for Audio Browsing," Proceedings of CHI '97, Mar. 22-27, 1997, pp. 194-201.
- Lai, "Touchpad," Notebook PC Manual, Beijing Acer Information Co., Ltd., Beijing, China, Feb. 16, 2005, 3 pages.
- Masui et al., "Elastic Graphical Interfaces for Precise Data Manipulation," CHI '95, 1995, 2 pages, ACM Press.
- Mattel, Inc., "Sylvania Intellivision Intelligent Television Master Component Service Manual," Sylvania, 1979, 3 pages.
- Mazuryk et al., "Two-Step Prediction and Image Deflection for Exact Head Tracking in Virtual Environments," Eurographics 1995, vol. 14, No. 3, 13 pages.
- Millman, et al., "Design of a High Performance Haptic Interface to Virtual Environments," IEEE, 1993, 7 pages.
- Mims, "A Few Quick Pointers, Mouses, Touch Screens, Touch Pads, Light Pads, and the Like Can Make Your System Easier to Use," Computers & Electronics, vol. 22, p. 64, May 1984, 6 pages.
- Mitsubishi Electric Research Lab, DiamondSpin Home Page, <http://diamondspin.free.fr>, 2013, 2 pages.
- Nass, "Touchpad Input Device Goes Digital to Give Portable Systems a Desktop 'Mouse-Like' Feel," Electronic Design, No. 44, No. 18, p. 51, Sep. 3, 1996, Penton Publishing Inc. Electronic Design, 2 pages.
- National Semiconductor, "Advance Information, FPD94128, 528-CH Small Format a-Si AMLCD Controller / Column Driver with Integrated Frame Buffer," May 2003, 4 pages, National Semiconductor Corporation.
- Newton, "MessagePad 2000 User's Manual," 304 pages, 1997, Apple Computer, Inc., Cupertino, CA.
- O'Malley, "BellSouth's Communicative Simon is a Milestone in the Evolution of the PDA," Byte.com, Dec. 1994, 5 pages, retrieved from <http://www.byte.com/art/9412/sec11/art3.htm>.
- PCMag, "Apple iPhone Is that the Internet in Your Pocket?," 6 pages, retrieved Jul. 22, 2013 from <http://www.pcmag.com/article2/0,2817,2152915,00.asp>.
- PCMag, "Apple iPhone Luscious Design and Interface," 6 pages, retrieved Jul. 22, 2013 from <http://www.pcmag.com/article2/0,2817,2082435,00.asp>.
- PCMag, "Apple iPhone the iPhone Bottom Line," 5 pages, retrieved Jul. 22, 2013 from <http://www.pcmag.com/article2/0,2817,2152919,00.asp>.
- Perenson, "New & Improved, Articles," PC Magazine, Sep. 10, 1996, 2 pages.
- Petersen, "Koalpad Touch Tablet & Micro Illustrator Software," InfoWorld Media Group, Oct. 10, 1983, 3 pages.
- Petruzzellis, "Force-Sensing Resistors," Electronics Now, Article, vol. 64, Issue No. 3, Mar. 1993, <http://search.ebscohost.com/login.aspx?direct=true&db=aph&AN=9305190116&site=ehost-live&scope=site>, 8 pages.
- Platt, "Apple iPhone Debut to Flop, Product to Crash in Flames," Suckbusters, 2007, 19 pages, <http://suckbusters2.blogspot.com/2007/06/apple-iphone-debut-to-flop-product-to.html>.
- Porges, "The Futurist: We Predict the iPhone will Bomb," TechCrunch, 2007, 4 pages, <http://techcrunch.com/2007/06/07/the-futurist-we-predict-the-iphone-will-bomb/>.
- Prokopovic, "Electric-Field Contact-less Sensing System, Designer Reference Manual" Freescale Semiconductor, Sep. 2006, 52 pages.
- Soderholm, Sensing Systems for 'Touch and Feel', Design News, Aug. 5, 1989, 6 pages.
- Spiwak, "A Great New Wireless Keyboard," Popular Electronics, vol. 14, No. 12, Dec. 1997, 8 pages.
- Spiwak, "A Pair of Unusual Controllers," Popular Electronics, vol. 14, Issue No. 4, Apr. 1997, 7 pages.
- Synaptics, Inc., "Synaptics TouchPad Interfacing Guide," 510-000080-A, Second Edition, Jan. 22, 2001, 93 pages.
- Tessler, "Point Pad," Macworld, Oct. 1995, vol. 12, No. 10, p. 87(1), 2 pages, Business & Company Resource Center—News/Magazine Display Page.
- Tessler, "Smart Input: How to Choose from the New Generation of Innovative Input Devices," Macworld, vol. 13, No. 5, p. 98(7), May 1996, Business & Company Resource Center—News/Magazine Display Page, 10 pages.
- Tessler, "Touchpads," Macworld, vol. 13, No. 2, p. 68(1), Mac Publishing, Feb. 1996, 4 pages.
- Triax, Inc., "Triax Custom Controllers Due; Video Game Controllers," HFD—The Weekly Home Furnishings Newspaper, vol. 67, No. 1, 2 pages, Jan. 4, 1993.
- Wacom Co., Ltd., "Technology," Saitama, Japan, 2002, 3 pages.
- Website, "Common Uses of JavaScript on HP.com," Itsy Pocket Computer Movies available at HP Labs, 2009, Hewlett-Packard Development Company, L.P., 1 page retrieved on Jul. 19, 2013 from <http://welcome.hp.com/country/us/en/noscript.html#summaryofsite-wide-JavaScript-functionality>.
- Wikipedia, "IBM Simon," retrieved from [http://en.wikipedia.org/wiki/IBM_Simon_\(phone\)](http://en.wikipedia.org/wiki/IBM_Simon_(phone)) on Nov. 21, 2008, 1 page.
- Ziegler, "The LG KE850: Touchable Chocolate," retrieved from <http://www.engadget.com/topics/mobile/2006/12/15/the-lg-ke850-touchable-chocolate> on Jul. 18, 2013, 3 pages.
- Jul. 8, 2011, Complaint by Apple, "Certain Portable Electronic Devices and Related Software," ITC Inv. No. 337-TA-, 35 pages.
- Aug. 12, 2011, "Order No. 1—Protective Order," No. 337-TA-797, 11 pages.
- Sep. 7, 2011, "HTC's Response," No. 337-TA-797, 29 pages.
- Sep. 14, 2011, "Trial Schedule," Order No. 4, Setting Procedural Schedule, Served on Sep. 14, 2011, 7 pages.
- Nov. 10, 2011, "Joint Motion of Apple and HTC to Amend Protective Order," Order No. 1, No. 337-TA-797, 22 pages.
- Nov. 14, 2010, "Apple's Identification Of Expert Witnesses," No. 337-TA-797, 173 pages.
- Nov. 14, 2011, "HTC Identification of Expert Witnesses," No. 337-TA-797, 432 pages.
- Dec. 2, 2011, "Order No. 18 Denying Joint Motion To Amend Protective Order," No. 337-TA-797, 5 pages.
- Dec. 8, 2011, "Apple First Amended Complaint," No. 337-TA-797, 34 pages.
- Dec. 21, 2011, "Apple Motion for Leave To File A Supplemental Identification of Expert Witnesses," No. 337-TA-797, 58 pages.
- Dec. 22, 2011, "Joint Motion of Apple and HTC to Amend Protective Order," No. 337-TA-797, 87 pages.
- Dec. 23, 2011, "HTC's Supplemental Notice of Prior Art regarding Newly Asserted Claims of U.S. RE '738," No. 337-TA-797, 9 pages.

(56)

References Cited

OTHER PUBLICATIONS

Jan. 3, 2012, "HTC Opposition to Apple's Motion For Leave To File A Supplemental Identification Of Expert Witnesses," No. 337-TA-797, 77 pages.

Jan. 18, 2012, "Apple Claim Construction Brief," No. 337-TA-797, 146 pages.

Jan. 18, 2012, "Joint Motion To Amend The Joint Claim Construction Statement," No. 337-TA-797, 78 pages.

Jan. 19, 2012, "Order No. 25: Granting Joint Motion To Amend The Joint Claim Construction Statement," No. 337-TA-797, 3 pages.

Jan. 20, 2012, "Order No. 26: Granting In Part Unopposed Joint Motion To Amend Protective Order," No. 337-TA-797, 21 pages.

Jan. 23, 2012, "HTC Response to First Amended Complaint," No. 337-TA-797, 31 pages.

Jan. 31, 2012, "Joint Motion of Apple and HTC To Extend Deadline For Technology Stipulation And Exchange Of Demonstrative Exhibits For Markman Hearing Request For Expedited Treatment," No. 337-TA-797, 6 pages.

Feb. 1, 2012, "Order No. 27: Granting Joint Motion to Extend Deadline For Technology Stipulation And Exchange Of Demonstrative Exhibits For The Markman Hearing," No. 337-TA-797, 3 pages.

Feb. 3, 2012, "Pre-Markman Hearing Statement Of Apple," No. 337-TA-797, 21 pages.

Feb. 3, 2012, "Pre-Markman Hearing Statement of HTC," No. 337-TA-797, 18 pages.

Feb. 3, 2012, "Pre-Markman Hearing Statement of Staff," No. 337-TA-797, 3 pages.

Feb. 6, 2012, "Order No. 28: Granting Joint Unopposed Motion For Leave to File Joint Technology Stipulation One Day Out of Time," No. 337-TA-797, 4 pages.

Feb. 10, 2012, "Apple Markman Demonstrative Public Exhibit List," No. 337-TA-797, 6 pages.

Feb. 10, 2012, "Apple Markman Public Exhibit List," No. 337-TA-797, 9 pages.

Feb. 10, 2012, "Joint Markman Public Exhibit List," No. 337-TA-797, 7 pages.

Feb. 17, 2012, "HTC Tentative Witness List," No. 337-TA-797, 22 pages.

Mar. 30, 2012, "Apple's Motion To Terminate Investigation With Respect to Certain Claims of '915," No. 337-TA-797, 7 pages.

Apr. 26, 2012, "Apple Motion Under Protective Orders For Authorization To Produce Confidential Information In District Court Proceedings," No. 337-TA-797, 91 pages.

May 3, 2012, "Apple's Renewed Motion To Terminate Investigation With Respect to Certain Claims of '915," No. 337-TA-797, 8 pages.

May 15, 2012, "Order No. 52: Initial Determination Granting Renewed Motion To Terminate Investigation With Respect To Certain Claims of '915," No. 337-TA-797, 5 pages.

May 29, 2012, "Notice of Commission Determination Not To Review An Initial Determination Terminating The Investigation As To Certain Asserted Patent Claims," No. 337-TA-797, 3 pages.

Jun. 12, 2012, "Correction Regarding Termination Request for Certain Claims of '915," No. 337-TA-797, 5 pages.

Jun. 22, 2012, "Corrected Notice Of Commission Determination Not To Review An Initial Determination Terminating The Investigation As To Certain Asserted Patent Claims," No. 337-TA-797, 3 pages.

Jun. 25, 2012, "Apple's Unopposed Motion To Terminate Investigation With Respect To Certain Claims," No. 337-TA-797, 10 pages.

Jun. 26, 2012, Order No. 57: Construing the Terms of the Asserted Claims of the Patents at Issue, No. 337-TA-797, 140 pages.

Jun. 26, 2012, "Order No. 58: Initial Determination Granting Motion To Terminate Investigation With Respect To Certain Claims," No. 337-TA-797, 6 pages.

Sep. 5, 2012, "Joint Final Exhibit List," No. 337-TA-797, 31 pages.

Nov. 7, 2012, HTC Notice of Supplemental Authority, No. 337-TA-797, 16 pages.

Nov. 14, 2012, "Order No. 70: Regarding Potential Termination Based Upon Settlement," No. 337-TA-797, 3 pages.

Nov. 27, 2012, "Order No. 73: Denying Without Prejudice The Private Parties' Joint Motion To Terminate," No. 337-TA-797, 7 pages.

Dec. 14, 2012, "Notice of Commission Determination Not To Review An Initial Determination Extending the Target Date By Approximately Three Weeks," No. 337-TA-797, 3 pages.

Jan. 14, 2013, "Notice of Commission Determination Not To Review an Initial Determination Terminating The Investigation; Termination Of Investigation," No. 337-TA-797, 3 pages.

[Video] Agarawala et al., Keepin' It Real: Pushing the Desktop Metaphor with Physics, Piles and the Pen In BumpTop, CHI '06, Youtube, Jun. 2006, (Video) retrieved from <http://www.youtube.com/watch?v=M0ODskdEPnQ&list=UUIjQ7ysXfuQfLhx-CTOdUtw&index=32&feature=plpp>.

[Video] Agarawala, "Bumptop," Ted.com, Mar. 2007, (Video), retrieved from http://www.ted.com/talks/lang/eng/anand_agarawala_demos_his_bumptop_desktop.html.

[Video] Agueray, "TED: Ideas Worth Spreading," (Video), 2007.

[Video] Author Unknown, "BumpTop", Jun. 2006, (Video), retrieved from <http://www.youtube.com/watch?v=oUVpSY4eBCc&list=UUIjQ7ysXfuQfLhx-CTOdUtw&index=31&feature=plpp>.

[Video] Author Unknown, "Creating Principle 3D Curves with Digital Tape Drawing," (Video), CHI 2002.

[Video] Author Unknown, "Two Handed Modeling," (Video) [date unavailable].

[Video] Balakrishnan et al., "Digital Tape Drawing," (Video), 1999.

[Video] Balakrishnan et al., "Exploring Interactive Curve and Surface Manipulation Using a Bend and Twist Sensitive Input Strip," (Video), 1999.

[Video] Balakrishnan et al., "ShapeTape Extra," (Video), 1999.

[Video] Balakrishnan et al., "Volumetric User Interfaces," (Video), 2007.

[Video] Balakrishnan et al., The Rockin Mouse—Integral 3D Manipulation on a Plane, (Video), CHI 1999.

[Video] Balakrishnan, "Suggestive Sketching," (Video), CHI 2004.

[Video] Balakrishnan, "Volumetric Selection Talk," (Video) UIST 2006.

[Video] Baudel, "Sketching with Ligne Claire," (Video), 1994.

[Video] Benko et al., "Precise Selection Techniques for Multi-Touch Screens," (Video), ACM SIGCHI 2006.

[Video] Bezerianos et al., "Interaction and Visualization Techniques for Very Large Scale High Resolution Displays," (Video), 2004.

[Video] Bezerianos et al., "Mnemonic Rendering Talk," (Video), UIST 2006.

[Video] Bezerianos et al., "Mnemonic Rendering: An Image-Based Approach for Exposing Hidden Changes in Dynamic Displays," (Video), UIST 2006.

[Video] Bezerianos et al., "The Vacuum: Facilitating the Manipulation of Distant Objects," (Video), CHI 2005.

[Video] Bolinsky, "TED: Ideas Worth Spreading," (Video), 2007.

[Video] BumpTop 1.0—3D Desktop Zen, YouTube, Apr. 2009, (Video) retrieved from <http://www.youtube.com/watch?v=eqcmPJ-oVL0&list=UUIjQ7ysXfuQfLhx-CTOdUtw&index=27&feature=plpp>, (Video).

[Video] BumpTop 3D Desktop Prototype, YouTube, Jun. 2006 (Video), retrieved from <http://www.youtube.com/watch?v=M0ODskdEPnQ>.

[Video] BumpTop 3D Multi-Touch Desktop, YouTube, Sep. 2009, retrieved from <http://www.youtube.com/watch?v=6jhoWsHwU7w&list=UUIjQ7ysXfuQfLhx-CTOdUtw&index=25&feature=plpp>, (Video).

[Video] BumpTop for Mac 1.0!, YouTube, Jan. 2010, (Video), retrieved from <http://www.youtube.com/watch?v=GcbymyM3dWo&list=UUIjQ7ysXfuQfLhx-CTOdUtw&index=24&feature=plpp>.

[Video] BumpTop Mac Leaf through a pile, Vimeo, 2009, (Video), retrieved from <http://vimeo.com/8823124>.

[Video] BumpTop Multitouch Part 1, YouTube, Jun. 2009, (Video), retrieved from <http://www.youtube.com/watch?v=PHUILmC3A1E&list=UUIjQ7ysXfuQfLhx-CTOdUtw&index=26&feature=plpp>.

[Video] BumpTop Touch, Multi-Touch Showcase, Vimeo, 2008, (Video) retrieved from <http://vimeo.com/1144121>.

[Video] Burtnyk et al., "Stylecam," (Video), UIST 2002.

[Video] Buxton et al., "Issues and Techniques in Touch-Sensitive Tablet Input," (Video), [date not available].

[Video] Buxton, "3D Modeling on Large Displays," (Video), 2001.

(56)

References Cited

OTHER PUBLICATIONS

- [Video] Buxton, "A Large Hemispheric Interactive Display for Visualization," (Video), 1994.
- [Video] Buxton, "A Study in Two-Handed Input," (Video), 1986.
- [Video] Buxton, "A Two-Handed Jog Shuttle Control for Digital Film and Animation," (Video), 1994.
- [Video] Buxton, "An Informal Study of Selection-Positioning Tasks," (Video), 1982.
- [Video] Buxton, "Bimanual Sweeps, Friskets and Stencils in a Digital Paint," (Video), 1995.
- [Video] Buxton, "Bom Chameleon with Portfolio Wall," (Video), 2003.
- [Video] Buxton, "Boom Chameleon—A Display for 3D Models," (Video), 1998.
- [Video] Buxton, "Crosspad Integrated with Design Studio," (Video), 1999.
- [Video] Buxton, "Digital Tape Drawing," (Video), 1995.
- [Video] Buxton, "Etch—A Study in Marking-Based Interaction," (Video), 1983.
- [Video] Buxton, "GEDIT—The Use of Single-Stroke Marks (Marking Menus)," (Video), 1982.
- [Video] Buxton, "Portfolio Wall, PDAs and the Society of Devices," (Video), 1999.
- [Video] Buxton, "Portfolio Wall," (Video), 1999.
- [Video] Buxton, "Studio Paint Utilizing the Existing Skills of the Artist," (Video), 1994.
- [Video] Buxton, "Templates on Touch Tablets to Support Virtual Devices," (Video), 1982.
- [Video] Buxton, "The Active Desk Prototyping the Future," (Video), 1992.
- [Video] Cao et al., "Interacting with Dynamically Defined Information Spaces Using a Handheld Projector and a Pen," (Video), UIST 2006.
- [Video] Cao et al., "VisionWand: Interaction Techniques for Large Displays Using a Passive Wand Tracked in 3D," (Video), UIST 2003.
- [Video] Fitzmaurice, et al., "A GUI Paradigm Using Tablets, Two-Hands and Transparency," (Video) [date unavailable].
- [Video] Fitzmaurice, et al., "Bricks: Laying the Foundation for Graspable User Interfaces," (Video), 1995.
- [Video] Fitzmaurice, et al., "Power Wall Stage with Tangible Props for Control," (Video), 1999.
- [Video] Forlines, et al., "HybridPointing Talk," (Video) 2006.
- [Video] Forlines, et al., "HybridPointing: Fluid Switching Between Absolute and Relative Pointing with a Direct Input Device," (Video), UIST 2006.
- [Video] Grossman, "Tovi Grossman on CP24," (Video), 2007.
- [Video] Grossman, "Tovi Grossman on Discovery Channel's Daily Planet," (Video), 2007.
- [Video] Grossman, et al., "An Interface for Curve Manipulation Using a High Degree of Freedom Curve Input Device," (Video) CHI 2003.
- [Video] Grossman, et al., "Hover Widgets: Using the Tracking State to Extend the Capabilities of Pen-Operated Devices," (Video), CHI 2006.
- [Video] Grossman, et al., "Interaction Techniques for 3D Modeling on Large Displays," (Video), 2001.
- [Video] Grossman, et al., "The Bubble Cursor: Enhancing Target Acquisition by Dynamic Resizing of the Cursor's Activation Area," (Video), CHI 2005.
- [Video] Hinrichs, "Hinrichs Siggraph 2005 Videosketch," (Video), 2005.
- [Video] ia Sheng et al., "Sculprox: An Interace for Virtual 3D Sculpting via Physical Proxy," (Video), Graphite 2006.
- [Video] Khan, et al., "Bimanual 3D Painting," (Video), [date unavailable].
- [Video] Malik et al., "Interacting with Large Displays from a Distance with Vision-Tracked Multi-Finger Gestural Input," (Video), UIST 2005.
- [Video] Mate, "A Graphical Text Annotation and Editing System," (Video) [date unavailable].
- [Video] McGuffin et al., "Interactive Visualization of Genealogical Graphs," (Video), 2005.
- [Video] McGuffin et al. "Using Deformations for Browsing Volumetric Data," (Video), 2003.
- [Video] McGuffin et al., "Expand-Ahead: A Space-Filing Strategy for Browsing Trees," (Video), Infovis 2004.
- [Video] Mitsubishi Electric Research Lab, FractalZoom Demo (Mandelbrot) at <http://www.youtube.com/watch?v=JKWe9U5PHmQ>, 2005.
- [Video] Mitsubishi Electric Research Lab, "MERL video," 2005, retrieved from <http://youtube.com/watch?v=t35HXAJNW6s>.
- [Video] Mitsubishi Electric Research Lab, "MSGE video," 2005, retrieved from <http://video.google.com/videoplay?docid=-388651346883829414>.
- [Video] Moscovich et al., "Multi-Finger Cursor Techniques," (Video), 2005.
- [Video] Moscovich, et al., "A Multi-Finger Manipulation Interface for Performance Animation of Deformable Drawings," (Video), 2005.
- [Video] Ramos et al., "Fluid Interaction Techniques for the Control and Annotation of Digital Video," (Video), UIST 2003.
- [Video] Ramos et al., "Pointing Lenses," (Video), CHI 2007.
- [Video] Ramos et al., "Pressure Marks," (Video), CHI 2007.
- [Video] Ramos et al., "Zliding: Fluid Zooming and Sliding for High Precision Parameter Manipulation," (Video) UIST 2005.
- [Video] Scott, "Scott Dissertation 2005 Storagebinvideo," (Video), 2005.
- [Video] Singh et al., "Visualizing 3D Scenes Using Non-Linear Projections and Data Mining of Previous Camera Movements," (Video), 2004.
- [Video] tabulaTouch, "TabulaMaps Running on a TabulaTouch—Interactive Multi-Touch Table," (Video), available on YouTube (<http://www.youtube.com/watch?v=12oMmCyiJZA>), 2006.
- [Video] TactaPad, "TactaDrawSmall," (Video), 2005.
- [Video] TactaPad, "TactaPadIntroSmall," (Video), 2005.
- [Video] Tactex Controls, Inc., "Flip Keyboard," (Video), 1982.
- [Video] Vogel et al., "Distant Freehand Pointing and Clicking on a Very Large, High Resolution Display," (Video) UIST 2005.
- [Video] Vogel et al., "Interactive Public Ambient Displays: Transitioning from Implicit TO Explicit, Public to Personal, Interaction with Multiple Users," (Video), UIST 2004.
- [Video] Vogel et al., "Occlusion-Aware Interlaces," (Video), CHI 2010.
- [Video] William et al., "A Multi-Touch Three Dimensional Touch-Sensitive Tablet," (Video), 1985.
- [Video] Wilson, "Robust Computer Vision-Based Detection of Pinching for One and Two-Handed Gesture Input," (Video), UIST 2006.
- [Video] Wu et al., "Multi-Finger and Whole Hand Gestural Interaction Techniques for Multi-User Tabletop Displays," (Video), UIST 2003.
- [Video] Zhao et al., "Simple vs. Compound Mark ierarchical Marking Menus," (Video), UIST 2004.
- Aboelsaadat et al., "An Empirical Comparison of Transparency on One and Two Layer Displays," pp. 1-20, [no date available].
- Advance Information, "FPD94128, 528-CH Small Format a-Si AMLCD Controller/Column Driver with Integrated Frame Buffer," 2003, 4 pages, National Semiconductor Corporation.
- Agarawala et al., "Keepin' It Real: Pushing the Desktop Metaphor with Physics, Piles and the Pen," CHI 2006, Apr. 22-27, 2006, 10 pages, Montreal, Quebec, Canada.
- Agarawala, "Anand Agarawala Demos BumpTop," Video on TED.com, TED ideas worth spreading, Sep. 2011, 7 pages, http://www.ted.com/index.php/talks/anand_agarawala_demos_his_bumptop_desktop.html.
- Agarawala, "Enriching the Desktop Metaphor with Physics, Piles and the Pen," Thesis, 2006, 102 pages, Association for Computing Machinery, Inc.
- Ahmad, "A Usable Real-Time 3D Hand Tracker," 5 pages, Interval Research Corporation, Palo Alto, CA, [no date available].
- Aliakseyeu et al., "A Computer Support Tool for the Early Stages of Architectural Design," Elsevier, *Interacting with Computers* 18, 2006, pp. 528-555.

(56)

References Cited

OTHER PUBLICATIONS

- Aliakseyeu et al., "Multi-Flick: An Evaluation of Flick-Based Scrolling Techniques for Pen Interfaces," CHI 2008 Proceedings: Pointing and Flicking, Apr. 5-10, 2008, pp. 1689-1698, Florence, Italy.
- Amershi, et al., "Multiple Mouse Text Entry for Single-Display Groupware," CSCW 2010, Feb. 6-10, 2010, pp. 169-178, Savannah, GA.
- Amon et al., "Concurrent Design and Analysis of the Navigator Wearable Computer System: The Termal Perspective," IEEE Transactions on Components, Packaging, and Manufacturing Technology-Part A, vol. 18, No. 3, Sep. 1995, pp. 567-577.
- Analog Devices, "Programmable Capacitance-to-Digital Converter with Environmental Compensation," 2005, 64 pages, Preliminary Technical Data AD7142/AD7142-1.
- Analog Devices, "Single Chip Accelerometer with Signal Conditioning," 1996, 20 pages.
- Angel, "Interactive Computer Graphics," 1997, 566 pages, Addison-Wesley Publishing Company, Reading, MA.
- Apple Inc., "Form 10-K Annual Report," Dec. 3, 2004, 132 pages EDGAR Online.
- Apple, "Cocoa Event-Handling Guide," Data Management: Event Handling, Oct. 7, 2009, 108 pages, Apple, Inc.
- ASMA, "Shaping the Future of 3-D," The Varsity Online, Dec. 3, 2002, 3 pgs., University of Toronto, <http://www.dgp.toronto.edu/~ravin/press/Varsity20020924.htm>[Sep. 14, 2011 12:53:03 PM].
- AT&T, "HTC Freestyle," Quick Start, 2 pages, 2010.
- AT&T, "HTC HD7S," Quick Start, 4 pages, 2011.
- AT&T, "HTC Jetstream," Quick Start, 4 pages, 2011.
- AT&T, "HTC Status," Quick Start, 4 pages, 2011.
- AT&T, "HTC Titan," Quick Start, 4 pages, 2011.
- AT&T, "HTC Vivid," Quick Start, 4 pages, 2011.
- Author Unknown, "Chart of Spatial Keyframing, Traditional Interfaces, Interface Techniques, 3D Control and Visulation and Ongoing Work," 1 page [No Date Available].
- Author Unknown, "Communication Arts," Interactive Annual 10, Sep./Oct. 2004, 215 pages, vol. 46, No. 5, Coyne & Blanchard, Menlo Park, USA.
- Author Unknown, "Communication Arts," Interactive Annual 11, Sep./Oct. 2005, 212 pages, vol. 47, No. 5, Coyne & Blanchard, Menlo Park, USA.
- Author Unknown, "Communication Arts," Interactive Annual 12, Sep./Oct. 2006, 207 pages, vol. 48, No. 5, Coyne & Blanchard, Menlo Park, USA.
- Author Unknown, "Communication Arts," Interactive Annual 9, Sep./Oct. 2003, 208 pages, vol. 45, No. 5, Coyne & Blanchard, Menlo Park, USA.
- Author Unknown, "Communication Arts," Sep./Oct. 2001, 247 pages, vol. 43, No. 5, Coyne & Blanchard, Menlo Park, USA.
- Author Unknown, "Error and Coupling: Extending Common Ground to Improve the Provision of Visual Information for Collaborative Tasks," pp. 1-35 [No Date Available].
- Author Unknown, "Pressure Adds Depth to Displays," An MIT Enterprise Technology Review, 2004, 2 pages, Technology Research News, <http://www.dgp.toronto.edu/~ravin/press/MIT-TechReview20040621.htm>.
- Author Unknown, Articles, "Hardware-Just Tilt to Enter Text, and Software-Digital Darwin," Innovation News, 2003, p. 24, Technology Review.
- Azuma et al., "Improving Static and Dynamic Registration in an Optical See-through HMD," SIGGRAPH '94, 1994, 17 pages, ACM, Orlando, FL.
- Bach, "The Design of the Unix Operating System," 1986, 489 pages, Prentice-Hall, Inc., Englewood Cliffs, NJ.
- Bae et al., "EverybodyLovesSketch: 3D Sketching for a Broader Audience," UIST '09, 2009, pp. 59-68, ACM, Victoria, British Columbia, Canada.
- Bae et al., "I Love Sketch: As-Natural-As-Possible Sketching System for Creating 3D Curve Models," UIST '08, 2008, pp. 151-160, ACM, Monterey, California.
- Baecker et al., "Readings in Human-Computer Interaction: A Multidisciplinary Approach," 1987, 752 pages, Morgan Kaufmann Publishers, Inc., Los Altos, CA.
- Baecker et al., "Readings in Human-Computer Interaction: Toward the Year 2000," Second Edition, 1995, 964 pages, Morgan Kaufmann Publishers, Inc., San Francisco, CA.
- Baecker et al., "The University of Toronto Dynamic Graphics Project," 2 pages, Computer Systems Research Institute, University of Toronto.
- Baguley, "Nokia's Small, Svelte, Internet-Savvy PDA," Jan. 31, 2006, 2 pp., PCWorld, http://www.pcworld.com/article/124456/nokias_small_svelte_internetsavvy_pda.html.
- Balakrishnan, et al., "Symmetric Bimanual Interaction," ACM CHI 2002 Conference, CHI Letters, vol. 2, No. 1, pp. 33-40, New York, NY.
- Balakrishnan et al., "Digital Tape Drawing," to appear in Proceedings of ACM UIST '99 Symposium on User Interface Software and Technology, 1999, pp. 1-9, ACM.
- Balakrishnan et al., "Exploring Bimanual Camera Control and Object Manipulation in 3D Graphics Interfaces," Proceedings of the 1999 ACM Conference on Human Factors in Computing Systems (CHI '99), 1999, pp. 56-63, ACM.
- Balakrishnan et al., "Exploring Interactive Curve and Surface Manipulation Using a Bend and Twist Sensitive Input Strip," Proceedings of the 1999 ACM Symposium on Interactive 3D Graphics (I3DG'99), 1999, pp. 111-118, ACM.
- Balakrishnan et al., "Performance Differences in the Fingers, Wrist, and Forearm in Computer Input Control," CHI 97, 1997, 8 pages, ACM, Atlanta, GA.
- Balakrishnan et al., "The PadMouse: Facilitating Selection and Spatial Positioning for the Non-Dominant Hand," Proceedings of the 1998 ACM Conference on Human Factors in Computing Systems (CHI '98), 1998, pp. 9-16, ACM.
- Balakrishnan et al., "The Rockin' Mouse: Integral 3D Manipulation on a Plane," Proceedings of the 1997 ACM Conference on Human Factors in Computing Systems (CHI '97), 1997, pp. 311-318, ACM.
- Balakrishnan et al., "User Interfaces for Volumetric Displays," Computer, 2001, pp. 37-45, IEEE.
- Balakrishnan et al., "Virtual Hand Tool With Force Feedback," Interactive Posters, Conference Companion, CHI '94, Apr. 24-28, 1994, 2 pages, Boston, MA.
- Balakrishnan, "Beating" Fitts' Law: Virtual Enhancements for Pointing Facilitation, Int. J. Human-Computer Studies, 2004, vol. 61, pp. 857-874.
- Balakrishnan, "Performance Differences in the Fingers, Wrist, and Forearm in Computer Input Control," Proceedings of the ACM Conference on Human Factors in Computing Systems (CHI '97), pp. 303-310, 1997, 9 pages.
- Balakrishnan, "Publications," 2011, 15 pages, <http://www.dgp.toronto.edu/~ravin/>.
- Balakrishnan, "The Role of Kinesthetic Reference Frames in Two-Handed Input Performance," UIST 1999, ACM Symposium on User Interface Software and Technology, CHI Letters, 1999, vol. 1, No. 1, pp. 171-178, ACM, New York.
- Barret et al., "Filters and Other Touch Screen Enhancements," 8 pages, iTouchInternational [No Date Available].
- Bartlett et al., "The Itsy Pocket Computer," 2000, 24 pages, Western Research Laboratory, Palo Alto, CA.
- Bartlett et al., "The Itsy Pocket Computer," Oct. 19, 1998, 15 pages, <http://www.hpl.hp.com/downloads/crl/itsy/talk-iswc98/sld001.html>.
- Bartlett, "Rock 'n' Scroll is Here to Stay" [Abstract only], Computer Graphics and Applications, IEEE, May/June, 2000, pp. 40-45, vol. 20, Issue 3, 1 page, as described in IEEE Xplore [http://ieeexplore.ieee.org/xpl/freeabs_all.jsp?amumber=844371][Feb. 5, 2011 15:34:48].
- Bartlett, "Rock 'n' Scroll is Here to Stay," May, 2000, 9 pages, Western Research Laboratory, Palo Alto, CA.
- Bartlett et al., "Itsy: An Open Platform for Pocket Computing Research," Jul. 1998, 21 pages, <http://www.hpl.hp.com/downloads/crl/itsy/talk-old/sld001.html>.
- Baxter, "Capacitive Sensors," Jun. 26, 2000, 17 pages.

(56)

References Cited

OTHER PUBLICATIONS

- Beck et al., "Two Devices for Operator Interaction In the Central Control Of The New CERN Accelerator," May 24, 1973, 18 pages, Geneva.
- Bederson et al., "Jazz: An Extensible 2D+Zooming Graphics Toolkit in Java," HCIL Technical Report No. 99-07, May, 1999, 10 pages, Human-Computer Interaction Lab, University of Maryland, College Park, MD.
- Bederson et al., "Jazz: An Extensible Zoomable User Interface Graphics Toolkit in Java," 11 pages, Human-Computer Interaction Lab, University of Maryland, College Park, MD [No Date Available].
- Bederson et al., "Pad++: A Zooming Graphical Interface for Exploring Alternate Interface Physics," UIST'94, Nov. 2-4, 1994, 10 pages, ACM.
- Benko et al., "Precise Selection Techniques for Multi-Touch Screens," CHI 2006, Apr. 22-28, 2006, 10 pgs., ACM, Montreal, Quebec, Canada.
- Benko et al., "Sphere: Multi-Touch Interactions on a Spherical Display," UIST '08, Oct. 19-22, 2008, pp. 77-86, ACM, Monterey, California.
- Bennett et al., "Communication Arts," vol. 48, No. 5, Sep./Oct. 2006, 207 pages.
- Bezerianos et al., "Interaction and Visualization Techniques for Very Large Scale High Resolution Displays, DGP-TR-2004-002" Jul. 21, 2004, 11 pages, UIST.
- Bezerianos et al., "Mnemonic Rendering: An Image-Based Approach for Exposing Hidden Changes in Dynamic Displays," UIST '06, Oct. 15-18, 2006, 10 pgs., ACM, Montreux, Switzerland.
- Bezerianos et al., "The Vacuum: Facilitating the Manipulation of Distant Objects," CHI 2005, Apr. 2-7, 2005, 10 pages, ACM, Portland, OR.
- Bezerianos et al., "View and Space Management on Large Displays," Jul./Aug. 2005, 10 pages, IEEE Computer Society.
- Bi et al., "Comparing Usage of a Large High-Resolution Display to Single or Dual Desktop Displays for Daily Work," CHI 2009 Proceedings: Large Displays/Multi-Display Environments, Apr. 4-9, 2009, pp. 1005-1014, ACM, Boston, Massachusetts.
- Bi, "An Exploration of Pen Rolling for Pen-Based Interaction," UIST '08, Oct. 19-22, 2008, pp. 191-200, ACM, Monterey, California.
- Bi, et al., "Effects of Interior Bezels of Tiled-Monitor Large Displays on Visual Search, Tunnel Steering, and Target Selection," ACM, Apr. 10-15, 2010, pp. 65-74, CHI 2010: Making Meaning in Large Displays, Atlanta, GA.
- Bic et al., "The Logical Design of Operating Systems," Second Edition, 1988, 387 pages, Prentice Hall, Englewood Cliffs, NJ.
- Bier et al., "A Taxonomy of See-Through Tools," Proceedings of CHI '94, 1994, 12 pages.
- Bier et al., "Snap-Dragging," vol. 20, No. 4, Aug. 18-22, 1986, 8 pp., ACM, Dallas, TX.
- Bier et al., "Toolglass and Magic Lenses: The See-Through Interface," Proceedings of SIGGRAPH '93, 1993, 15 pages.
- Bier, "Snap-Dragging: Interactive Geometric Design in Two and Three Dimensions," May 19, 1988, 170 pages.
- Biesen, "Cooking Collision," Aug. 2005, 8 pages, http://www.appliancemagazine.com/zones/supplier/20_finishing/editorial.php?artide=10.
- Birnholtz et al., "An Exploratory Study of Input Configuration and Group Process in a Negotiation Task Using a Large Display," CHI 2007 Proceedings: Large Displays, Apr. 28-May 3, 2007, pp. 91-100, ACM, San Jose, California.
- Birnholtz et al., "Using Motion Tracking Data to Augment Video Recordings in Experimental Social Science Research," journal, date, and publication information unknown, 10 pgs. [No Date Available].
- Blasko et al., "Single-Handed Interaction Techniques for Multiple Pressure-Sensitive Strips," CHI 2004, Apr. 24-29, 2004, 4 pages, ACM, Vienna, Austria.
- Bleser et al., "Charcoal Sketching: Returning Control to the Artist," ACM Transactions on Graphics, vol. 7, No. 1, Jan. 1988, pp. 76-81, ACM.
- Bleser et al., "Toto: A Tool for Selecting Interaction Techniques," 1990, 8 pages, ACM.
- Blount, "Orange Scribble," Howard Forums Mobile Community, accessed at <http://www.howardforums.com/shrowthread.php/31351-New-P800-P900-app-OrangeScri...>, Oct. 7, 2011, 4 pages.
- Bohn, "Computer-Aided Design I Term Papers," Virginia Tech, 1997, 38 pages.
- Boie, "Capacitive Impedance Readout Tactile Image Sensor," IEEE, 1984, 9 pages, Bell Laboratories, Murray Hill, NJ.
- Bolognesi et al., "Introduction to the ISO Specification Language LOTOS," 1987, 35 pages, Elsevier Science Publishers B.V., North-Holland.
- Borman et al., "Human Factors in Computing Systems," 1985, 221 pages, CHI '85 Conference Proceedings, Apr. 14-18, 1985, San Francisco, Special Issue of the Sigchi Bulletin.
- Bouluc et al., "Multi-Finger Manipulation of Virtual Objects," Proceedings of ACM Symposium on Virtual Reality Software and Technology (VRST '96), Jul. 1996, pp. 67-74, ACM, Hong Kong.
- Bowman, "The Slippery Desktop," cbc.ca, CBC News Indepth: Tech, 2006, 3 pgs., <http://www.dgp.toronto.edu/~ravin/press/CBC20060629bumptop.html>[Sep. 14, 2001 12:46:50 PM].
- Brooks et al., "Advanced Technology for Portable Personal Visualization," Jan-Jun. 1992, 119 pages.
- Brose et al., "Java Programming with COBRA," Third Edition, 2001, 745 pages, Wiley Computer Publishing, New York.
- Brown et al., "Windows on Tablets as a Means of Achieving Virtual Input Devices," Human-Computer Interaction—INTERACT '90, 1990, pp. 675-681, Elsevier Science Publishers B.V., Amsterdam, Holland.
- Browne et al., "Designing a Collaborative Finger Painting Application for Children," 8 pages, Human-Computer Interaction Lab, University of Maryland, College Park, MD [No Date Available].
- Burtnyk et al., StyleCam: Interactive Stylized 3D Navigation using Integrated Spatial & Temporal Controls, Published in ACM CHI Letters, 4(2), pp. 101-110, ACM UIST 2002 Symposium on User Interface Software & Technology.
- Butler, "Portable MP3: The Nomad Jukebox," Jan. 8, 2001, 5 pages, <http://tidbits.com/article/6261>.
- Buxton et al., "A Study In Two-Handed Input," Proceedings of CHI '86, 1986, 9 pages, University of Toronto.
- Buxton et al., "A Computer-Based System for the Performance of Electroacoustic Music," 1979, 10 pages, An Audio Engineering Society Preprint.
- Buxton et al., "A Microcomputer-based Conducting System," 14 pages, Structured Sound Synthesis Project, Computer Systems Research Group, University of Toronto, Toronto, Ontario, CA [no date available].
- Buxton et al., "Continuous Hand-Gesture Driven Input," Proceedings of Graphics Interface'83, 9th Conference of the Canadian Man-Computer Communications Society, 1983, pp. 191-195, Edmonton, Canada.
- Buxton et al., "EuroPARC's Integrated Interactive Intermedia Facility (IIIF): Early Experiences," Multiuser Interfaces and Applications, Proceedings of the IFIP WG 8.4 Conference on Multi-User Interfaces and Applications, 1990, pp. 11-34, Elsevier Science Publishers B.V., Amsterdam, Holland.
- Buxton et al., "Issues and Techniques in Touch-Sensitive Tablet Input," SIGGRAPH, Jul. 22-26, 1985, vol. 19, No. 3, 10 pages, San Francisco, CA.
- Buxton et al., "Iteration in the Design of the Human-Computer Interface," Proceedings of the 13th Annual Meeting, Human Factors Association of Canada, 1980, pp. 72-81.
- Buxton et al., "Large Displays in Automotive Design," IEEE Computer Graphics and Applications, Jul./Aug. 2000, pp. 68-75, IEEE.
- Buxton et al., "Objed and the Design of Timbral Resources," Computer Music Journal, 1982, vol. 6, No. 2, pp. 32-44, Massachusetts Institute of Technology, MA.
- Buxton et al., "Scope in Interactive Score Editors," Computer Music Journal, 1981, vol. 5, No. 3, Massachusetts Institute of Technology, MA.
- Buxton et al., "The Evolution of the SSSP Score Editing Tools," Computer Music Journal 3(4), 14-25, 1979; reprinted in: 1985, The Evolution of the SSSP Score Editing Tools, In Roads, C. & Strawn, J.,

(56)

References Cited

OTHER PUBLICATIONS

1985, Foundations of Computer Music, MIT Press, Cambridge, MA, 376-402; accessed from <http://www.billbuxton.com/SSSP.html> Sep. 14, 2011, 17 pages.

Buxton et al., "The Use of Hierarchy and Instance in a Data Structure for Computer Music," *Computer Music Journal*, vol. II, No. 4, 11 pages.

Buxton et al., "Towards A Comprehensive User Interface Management System," *Computer Graphics*, Jul. 1983, vol. 17, No. 3.

Buxton et al., "An Introduction to the SSSP Digital Synthesizer," 11 pages, vol. II, No. 4, *Computer Music Journal*, Menlo Park, CA [No Date Available].

Buxton, "31.1: Invited Paper: A Touching Story: A Personal Perspective on the History of Touch Interfaces Past and Future," *Society for Information Display (SID) Symposium Digest of Technical Papers*, 2010, pp. 444-448, May 2010, vol. 41(1), Session 31.

Buxton, "A Composer's Introduction to Computer Music," *Interface*, 1977, pp. 57-72, vol. 6.

Buxton, "A Three-State Model of Graphical Input," *Human-Computer Interaction—INTERACT '90*, 1990, pp. 449-456, Elsevier Science Publishers B.V., Amsterdam, Holland.

Buxton, "Absorbing and Squeezing Out: On Sponges and Ubiquitous Media," *Proceedings of the International Broadcasting Symposium*, 1996, pp. 91-96 [<http://www.billbuxton.com/sponges.html>].

Buxton, "An Informal Study of Selection-Positioning Tasks," *Proceedings of the Graphics Interface '82*, 8th Conference of the Canadian Man-Computer Communications Society, 1982, pp. 323-328, Toronto, Canada.

Buxton, "Integrating The Periphery and Context: A New Taxonomy of Telematics," *Proceedings of Graphics Interfaces '95*, 1995, pp. 239-246 [http://www.billbuxton.com/BG_FG.html].

Buxton, "Introduction to This Special Issue on Nonspeech Audio," *Human-Computer Interaction*, 1989, pp. 1-9, vol. 4, Lawrence Erlbaum Associates, Inc.

Buxton, "Lexical And Pragmatic Considerations of Input Structures," *Computer Graphics* 17(1), 1983, 9 pages.

Buxton, "Living in Augmented Reality: Ubiquitous Media and Reactive Environments," *Video Mediated Communication*, 1997, pp. 363-384, Erlbaum, Hillsdale, NJ [<http://www.billbuxton.com/augmentedReality.html>].

Buxton, "Masters and Slaves Versus Democracy: MIDI and Local Area Networks," *Proceedings of the 5th International Conference on Music and Digital Technology*, May 1-3, 1987, 8 pages, Audio Engineering Society, Anaheim, CA.

Buxton, "Metaphors that Keep Us on the Periphery," *Human Computer Interaction*, 1994, 3 pages, <http://www.billbuxton.com/metaphors.html>.

Buxton, "Performance by Design: The Role of Design in Software Product Development," Oct. 26-29, 2003, pp. 1-15.

Buxton, "Telepresence: Integrating Shared Task and Person Spaces," *Proceedings of Graphics Interface '92*, pp. 123-129 [http://www.billbuxton.com/shared_space.html].

Buxton, "The 'Natural' Language of Interaction: A Perspective on Non-Verbal Dialogues," 1988, pp. 428-438, vol. 26, No. 4, *Canadian Journal of Operations Research and Information Processing* [<http://www.billbuxton.com/natural.html>].

Buxton, "The Long Nose of Innovation," *Bloomberg Businessweek*, *BusinessWeek.com*, Jan. 2, 2008, 7 pgs., http://www.businessweek.com/innovate/content/jan2008/id2008012_297369.htm [Sep. 7, 2011 4:31:15 PM].

Buxton, "Thought on the State of 3D CG in Film and Video," May/ Jun. 2005, 4 pages, IEEE Computer Society.

Buxton, "Using Our Ears: An Introduction to the Use of Nonspeech Audio Cues," *Extracting Meaning From Complex Data: Processing, Display, Interaction*, 1990, 2 pgs., *Proceedings of the SPIE*, vol. 1259.

Buxton., "Chunking and Phrasing and the Design of Human-Computer Dialogues," *Proceedings of the IFIP World Computer Congress*, 1986, 9 pages, Dublin, Ireland.

Cao et al., "Evaluation of an On-line Adaptive Gesture Interface with Command Prediction," 8 pages, University of Toronto [No Date Available].

Cao et al., "Flashlight Jigsaw: An Exploratory Study of an Ad-Hoc Multi-Player Game on Public Displays," *CSCW '08*, Nov. 8-12, 2008, pp. 77-86, ACM, San Diego, California.

Cao et al., "Interacting with Dynamically Defined Information Spaces Using A Handheld Projector and a Pen," *UIST '06*, Oct. 15-18, 2006, pp. 225-234, ACM, Montreux, Switzerland.

Cao et al., "Multi-User Interaction Using Handheld Projectors," *UIST '07*, Oct. 7-10, 2007, pp. 43-52, ACM, Newport, Rhode Island.

Cao et al., "Peephole Pointing: Modeling Acquisition of Dynamically Revealed Targets," *CHI 2008 Proceedings: Pointing and Flicking*, Apr. 5-10, 2008, pp. 1699-1708, ACM, Florence, Italy.

Cao et al., "ShapeTouch: Leveraging Contact Shape on Interactive Surfaces," *IEEE Int'l. Workshop on Horizontal Interactive Human Computer System (Tabletop)*, 2008, 139-146, IEEE.

Cao et al., "VisionWand: Interaction Techniques for Large Displays using a Passive Wand Tracked in 3D," *2003 ACM*, pp. 173-182, *UIST*, Vancouver, BC, Canada.

Captain, "Future Gear: Keyless (Data) Entry," Apr. 24, 2002, 7 pages, http://www.pcworld.com/article/95263/future_gear_keyless_data_entry.html.

Carlson, "Multiphase Flow Measurements Using Ultrasound," December, *LuLea University of Technology*, 1999, 55 pages.

Carpendale et al., "Collaborative Interaction on Large Tabletop Displays," *CSCW 2006*, Nov. 4-8, 2006, pp. 57-58, Banff, Alberta, Canada.

Carpendale, "Roles of Orientation in Tabletop Collaboration: Comprehension, Coordination and Communication," 33 pages, *University of Calgary, Alberta, Canada* [No Date Available].

Carr et al., "The Power of PenPoint," 1991, 357 pages, Addison-Wesley Publishing Company, Inc.

Casiez et al., "The Impact of Control-Display Gain on User Performance in Pointing Tasks," *Human-Computer Interaction*, 2008, pp. 215-250, vol. 23:3, Taylor & Francis (online), <http://dx.doi.org/10.1080/07370020802278163>.

CEI IEC, "Low-Voltage Switchgear and Controlgear—Part 5-2: Control Circuit Devices and Switching Elements—Proximity Switches," 1997, *International Standard, Second Edition*, 182 pages.

CENA, "DigiStrips humaniser les interfaces," 1 page, Toulouse, France [No Date Available].

Cern Courier, "The First Capacitive Touch Screens at CERN," Mar. 31, 2010, 8 pages, <http://www.cerncourier.com/cws/artcle/cem/42092>.

Chang et al., "Animation: From Cartoons to the User Interface," *SMLI Technical Report*, Mar. 1995, 18 pgs., Sun Microsystems Laboratories, Mountain View, CA.

Chang et al., "Communication Arts," vol. 47, No. 5, Sep./Oct. 2005, 212 pages.

Chen et al., "A Study in Interactive 3-D Rotation Using 2-D Control Devices," *Computer Graphics*, vol. 22, No. 4, Aug. 1988, 9 pages, ACM.

Cheng et al., "Navigation Control and Gesture Recognition Input Device for small, Portable User Interfaces," Jun. 11, 2004, 14 pages, Synaptics Incorporated.

Christensen et al., "Frameworks in CS1—a Different Way of Introducing Event-driven Programming," *ITiCSE '02*, Jun. 24-26, 2002, 5 pages, ACM, Aarhus, Denmark.

Chu et al., "Featherweight Multimedia for Information Dissemination," manuscript, 11 pgs.

Chu et al., "Haptic Conviction Widgets," *Graphics Interface Conference*, May 25-27, 2009, pp. 207-210, ACM, Kelowna, British Columbia.

Chun et al., "A High-Performance Silicon Tactile Imager Based on a Capacitive Cell," *IEEE Transactions on Electron Devices*, Jul. 1985, vol. ED-32, No. 7, 6 pages.

Cooperstock et al., "Evolution of a Reactive Environment," *Proceedings of the ACM Conference on Human Factors in Computing Systems (CHI '95)*, 1995, pp. 170-177, ACM, New York [<http://www.billbuxton.com/ReadEnv.html>].

Cooperstock et al., "Reactive Environments," *Communications of the ACM*, Sep. 1997, pp. 65-73, vol. 40, No. 9.

(56)

References Cited

OTHER PUBLICATIONS

- Crowley Milling, "How CERN broke the software barrier," *New Scientist* 29, vol. 75, No. 1071, Sep. 1977, 3 pages.
- Culwin, "A Java GUI Programmer's Primer," 1998, 337 pages, Prentice-Hall, Upper Saddle River, NJ.
- Dannenberg et al., "A Gesture Based User Interface Prototyping System," 1989, 6 pages, ACM.
- Davidson et al., "Synthesis and Control on Large Scale Multi-Touch Sensing Displays," NIME 06, Jun. 4-8, 2006, Proceedings of the 2006 International Conference on New Interfaces for Musical Expression, pp. 216-219, Paris, France.
- Davies, "Lateral histograms for efficient object location: Speed versus ambiguity," *Pattern Recognition Letters*, vol. 6, No. 3, Aug. 1987, 10 pages, Elsevier Science Publishers B.V., North Holland.
- Davies, "Machine Vision: Theory, Algorithms, Practicalities," 1990, 568 pages, Academic Press Inc., San Diego, CA.
- Davis, "Flash To The Core An Interactive Sketchbook," 2003, 20 pages, New Riders Publishing, USA.
- Deitel et al., "Java How to Program Fourth Edition," 1995, 1383 pages, Prentice-Hall, Inc., Upper Saddle River, NJ.
- Deitel, et al., "Java How to Program, Fourth Edition," 2002, Prentice Hall, Upper Saddle River, NJ.
- den Boer, "Active Matrix Liquid Crystal Displays, Fundamentals and Applications," 2005, 6 pages, Elsevier, Inc., Oxford, UK.
- Denning, "The Invisible Future," 2002, 363 pages, McGraw-Hill, NY.
- Dietz et al., "DT Controls: Adding Identity to Physical Interfaces," UIST '05, 2005, 8 pages, ACM, Seattle, WA.
- Dietz et al., "Submerging Technologies," 1 page, Mitsubishi Electric Research Labs [No Date Available].
- Dietz et al., DiamondTouch: A Multi-User Touch Technology, Oct. 2003, 10 pages, Mitsubishi Electric Research Laboratories, Inc., Cambridge, MA.
- DigiStrips, "DigiStrips, or electronic strips on touch screens," Mar. 2001, 4 pages, [mhtml:file:///S:\DFSR_DATA/Data01\051900\Prior Art\915\00—Michael Kobayashi\10.1...](http://mhtml:file:///S:\DFSR_DATA\Data01\051900\Prior Art\915\00—Michael Kobayashi\10.1...)
- Digital Image Fest, "Your Computer Animation Festival To Go," Jun. 30, 2006, 1 page, <http://www.dgp.toronto.edu/~ravin/press/DigitalImageFestEpisode005.html>.
- Dolan et al., "Communication Arts," vol. 43, No. 5, Sep./Oct. 2001, 247 pages.
- Dragicevic et al., "Video Browsing by Direct Manipulation," CHI 2008 Proceedings: Improved Video Navigation and Capture, Apr. 5-10, 2008, pp. 237-246, ACM, Florence, Italy.
- DSNA, "Activity related to Vigiestrips: study of a support of flight plan information devised for the benefit of the Watchtower," 2011, 4 pages, [mhtml:file:///S:\DFSR_DATA/Data01\051900\Prior Art\915\00—Michael Kobayashi\10.1...](http://mhtml:file:///S:\DFSR_DATA\Data01\051900\Prior Art\915\00—Michael Kobayashi\10.1...) [no date available].
- DSNA, "Vigiestrips Making Strips a part of A-SMGCS," 14 pp., CENA [No Date Available].
- DSNA, "Vigiestrips," 2001, 2 pages, Bertin Technologies.
- Dubroy et al., "A Study of Tabbed Browsing Among Mozilla Firefox Users," ACM, 2010, pp. 673-682, CHI Apr. 10-15, 2010: Browsing, Atlanta, GA.
- Duce et al., "An Approach to Hierarchical Input Devices," 1980, 16 pages, Rutherford Appleton Laboratory, Chilton, Didcot, Oxon, UK.
- Duce et al., "Components, Frameworks and GKS Input," 1980, 20 pages, Rutherford Appleton Laboratory, Chilton, Didcot, Oxon, UK.
- Dupont et al., "Automatic Identification of Environment Haptic Properties," accepted for publication in *Presence: Teleoperators and Virtual Environments*, Mar. 1999, 27 pgs.
- Elo Touch Systems, "Corporate Facts at a Glance Tyco Electronics," 2011, 2 pages, <http://www.elotouch.com/AboutElo/Facts/default.asp>.
- Elo Touchsystems, "CarrollTouch Infrared Touch Technology," 2011, 4 pages, <http://www.elotouch.com/Technologies/CarrollTouch/default.asp>.
- Elo Touchsystems, Elo IntelliTouch/Secure Touch Touchscreen Guide, 1989, 105 pages, Elo TouchSystems, Inc.
- Elo Touchsystems, "MonitorMouse for Macintosh Release 3.0," Nov. 21, 1997, 1 page, <http://www.elotouch.com/Products/Updates/pmb000152.asp>.
- Elo Touchsystems, "Projected Capacitive," 2006, 2 pages, Tyco Electronics Corporation Elo-152 3106.
- Elo Touchsystems, "Touchscreen, touchmonitor and other touch product updates," 2011, 13 pages, <http://www.elotouch.com/Products/Updates>.
- Englander, "Developing Java Beans," 1997, 326 pages, O'Reilly, Sebastopol, CA.
- EPP, "Prelude to Patterns in Computer Science Using Java Beta Edition," 2001, 972 pages, Franklin, Beedle & Associates, Incorporated, Wilsonville, OR.
- Epps et al., "A Study of Hand Shape Use in Tabletop Gesture Interaction," CHI 2006, Apr. 22-27, 2006, 6 pages, ACM, Montreal, Quebec, Canada.
- Ergonomic Requirements for Office Work with Visual Display Terminals (VDTs), 2000, 54 pages.
- Erickson, "Working with Interface Metaphors," *The Art of Human-Computer Interface Design*, 1990, pp. 65-73, Addison-Wesley/Apple Computer, Inc., Castleton, NY.
- Esenther et al., "DiamondTouch SDK: Support for Multi-User, Multi-Touch Applications," CSCW 2002 Demo, Nov. 2002, 5 pages, Mitsubishi Electric Research Laboratories, Inc., Cambridge, MA.
- Esenther et al., "Fluid DTMouse: Better Mouse Support for Touch-Based Interactions," AVI, May 2006, 5 pages, Mitsubishi Electric Research Laboratories, Inc., Cambridge, MA.
- Esenther et al., "Multi-User Multi-Touch Games on DiamondTouch with the DTFlash Toolkit," *Intelligent Technologies for Interactive Entertainment 2005*, Dec. 2005, 5 pages, Mitsubishi Electric Research Laboratories, Inc., Cambridge, MA.
- Esenther et al., "RemoteDT: Support for Multi-Site Table Collaboration," CollabTech 2006, Jul. 2006, 7 pages, Mitsubishi Electric Research Laboratories, Inc., Cambridge, MA.
- Esenther, "Multi-Touch Gestures for Controlling Synchronized Map Views," ESRI International User Conference, 2008, Mitsubishi Electric Research Labs., 26 pgs., Cambridge, Massachusetts.
- Esteban et al., "Visual construction of highly interactive applications," CENA/PII/95.641/O Version 1, 15 pages [no date available].
- Everitt et al., "Modal Spaces: Spatial Multiplexing to Mediate Direct-Touch Input on Large Displays," CHI 2005, Apr. 2005, 5 pages, Mitsubishi Electric Research Laboratories, Inc., Cambridge, MA.
- Everitt et al., "MultiSpace: Enabling Electronic Document Micro-mobility in Table-Centric, Multi-Device Environments," IEEE, Oct. 2005, 9 pages, Mitsubishi Electric Research Laboratories, Inc., Cambridge, MA.
- Everitt et al., "Observations o a Shared Tabletop User Study," CSCW, Jan. 2004, 4 pages, Mitsubishi Electric Research Laboratories, Inc., Cambridge, MA.
- Everitt, "UbiTable: Impromptu Face-to-Face Collaboration on Horizontal Interactive Surfaces," Sep. 2003, 10 pages, Mitsubishi Electric Research Laboratories, Inc., Cambridge, MA.
- Faconti et al., "The Input Model of Standard Graphics Systems Revisited by Formal Specification," EUROGRAPHICS '92, vol. 11, No. 3, 1992, 15 pages, Blackwell Publishers.
- Fearing, "Tactile Sensing Mechanisms," *The International Journal of Robotics Research*, Jun. 1990, 22 pages, Sage Publications.
- Fearing, "Tactile Sensing, Perception and Shape Interpretation," 1987, 164 pages.
- Fedorkow et al., "A Computer-Controlled Sound Distribution System for the Performance of Electroacoustic Music," *Computer Music Journal*, vol. II, No. 3, 10 pages [no date available].
- Ferg, "Event-Driven Programming: Introduction, Tutorial, History," Feb. 8, 2006, 59 pages, Creative Commons Attribution License, accessed from http://Tutorial_EventDrivenProgramming.sourceforge.net.
- Findlater et al., "Comparing Semiliterate and Illiterate Users' Ability to Transition from Audio+Text to Text-Only Interaction," CHI 2009 Proceedings: Mobile Applications for the Developing World, Apr. 8, 2009, pp. 1751-1760, ACM, Boston, Massachusetts.
- Fingerworks, "Arrow keys for iGesture Mini," 2003, 2 pages, vBulletin, <http://forums.fingerworks.com/showthread.php?=233>.

(56)

References Cited

OTHER PUBLICATIONS

- Fingerworks, "Gesture Guide Tip and Tricks," 2009, 1 page, http://www.fingerworks.com/gesture_guide_tips.html.
- Fingerworks, "Gesture Guide," 2009, 1 pages, http://www.fingerworks.com/gesture_guide_web.html.
- Fingerworks, "Installation and Operation Guide for the TouchStream ST and TouchStream LP," 2002, 14 pages, www.fingerworks.com.
- Fingerworks, "Inventor and Developer of MultiTouch Technology," 2011, 191 pages, <http://www.dgp.toronto.edu/dwigdor/nb/fingerworks/www/index.html>.
- Fingerworks, "Mouse Emulation Gesture Guide," 2009, 1 page, http://www.fingerworks.com/gesture_guide_mouse.html.
- Fingerworks, "My Gesture Editor Gesture Mapping," 2009, 5 pages, http://www.fingerworks.com/MyGestureEditor_mapping.html.
- Fingerworks, "Right Hand Gesture/Hotkey Mappings for all TouchStream and iGesture Products," 2009, 2 pages, http://www.fingerworks.com/gesture_keymap.html.
- Fingerworks, "TouchStreamLP Programmable USB Keyboard with Integrated Pointing and Hand Gesture," 2011, 2 pages, http://dgp.toronto.edu/~dwigdor/nb/fingerworks/www/lp_product.html.
- Fingerworks, "Troubleshooting and Firmware Upgrades," 2009, 7 pages, <http://www.fingerworks.com/troubleshooting/html#gesture>.
- Fingerworks, "US Qwerty and Dvorak Keyboard Layouts," 2011, 4 pages, <http://www.dgp.toronto.edu/~dwigdor/nb/fingerworks/www/layouts.html>.
- Fingerworks, "Welcome to FingerWorks," 2009, 2 pages, <http://www.fingerworks.com/>.
- Fishkin et al., "Embodied User Interfaces: Towards Invisible User Interfaces," Proceeding of EHCI '98, Sep. 13-18, 1998, 18 pages, Heraklion, Crete.
- Fitzmaurice et al., "An Empirical Evaluation of Graspable User Interfaces: Towards Specialized, Space-Multiplexed Input," Proceedings of the ACM Conference on Human Factors in Computing Systems (CHI '97), 1997, pp. 43-50, ACM [<http://www.billbuxton.com/graspableUI.html>].
- Fitzmaurice et al., "An Exploration Into Supporting Artwork Orientation in the User Interface," Proceedings of the 1999 ACM Conference on Human Factors in Computing Systems (CHI '99), 1999, pp. 167-174, ACM.
- Fitzmaurice et al., "Bricks: Laying the Foundations for Graspable User Interfaces," Proceedings of the ACM Conference on Human Factors in Computing Systems (CHI '95), 1995, pp. 432-449, ACM, New York [<http://www.billbuxton.com/bricks.html>].
- Fitzmaurice et al., "Bricks: Laying the Foundations for Graspable User Interfaces," CHI '95, May 7-11, 1995, 8 pages, ACM, Denver, CO.
- Fitzmaurice et al., "Sampling, Synthesis, and Input Devices," Communications of the ACM, Aug. 1999, 10 pgs., vol. 42, No. 8, ACM.
- Fitzmaurice et al., "Situating Information Spaces and Spatially Aware PalmTop Computers," Communications of the ACM, vol. 36, No. 7, Jul. 1993, 11 pages.
- Fitzmaurice et al., "Tracking Menus," 2003, pp. 71-80, Letters CHI, vol. 5, No. 2, Vancouver, BC, Canada.
- Fitzmaurice et al., "Virtual Reality for Palmtop Computers," ACM Transactions on Information Systems, vol. 11, No. 3, Jul. 1993, 22 pages, ACM.
- Fitzmaurice, et al., "Sentient Data Access via a Diverse Society of Devices," Nov. 2003, QUEUE, 12 pages.
- Flanagan, "In A Nutshell," Fifth Edition, 2005, 1251 pages, O'Reilly Media, Inc., Sebastopol, USA.
- Flanagan, "In A Nutshell," Second Edition, 1997, 629 pages, O'Reilly Media, Inc., Sebastopol, USA.
- Flanagan, "JavaScript The Definitive Guide," Fifth Edition, 2006, 1014 pages, O'Reilly Media, Inc., Sebastopol, USA.
- Flanagan, "JavaScript The Definitive Guide," Fourth Edition, 2002, 927 pages, O'Reilly Media, Inc., Sebastopol, USA.
- Flashloaded Expand Your Flash, <http://web.archive.org/web/20070101103734/www.flashloaded.com/flashcomponents/>, 2006, 3 pages, FFF Web Media, Inc.
- Flashloaded, "slideMenu" Printout from Archive.org, Jan. 2007, 1 page <http://www.flashloaded.com/flashcomponents/slidemenu/>.
- Foley et al., "Computer Graphics, Principles and Practice," Second Edition in C, 1990, The Systems Programming Series, 1276 pages, Addison-Wesley Publishing Company, Inc.
- Foley et al., "Computer Graphics: Principles and Practice," Second Edition, 1987, 634 pages, Addison-Wesley Publishing Company.
- Foley et al., "Introduction to Computer Graphics," 1990, 605 pages, Addison-Wesley.
- Foley et al., "The Art of Natural Graphic Man-Machine Conversation," Proceedings of the IEEE, vol. 62, No. 4, Apr. 1974, 10 pages, University of North Carolina, Chapel Hill, NC.
- Foo, "Jackito-Tactile Digital Assistant," Mar. 28, 2005, 1 page, cnet asia, <http://asia.cnet.com/crave/jackito-tactile-digital-assistant-62100186.htm>.
- Forlines et al., "Direct Touch vs. Mouse Input for Tabletop Displays," CHI 2007 Proceedings: Mobile Interaction Techniques I, Apr. 28-May 3, 2007, pp. 647-656, ACM, San Jose, California.
- Forlines et al., "DTLens: Multi-User Tabletop Spatial Data Exploration," ACM Symposium on User Interface Software and Technology, Oct. 2005, 5 pages, Mitsubishi Electric Research Laboratories, Inc., Cambridge, MA.
- Forlines et al., "Evaluating Tactile Feedback and Direct vs. Indirect Stylus Input in Pointing and Crossing Selection Tasks," CHI 2008 Proceedings: Tactile and Haptic User Interfaces, Apr. 5-10, 2008, pp. 1563-1572, ACM, Florence, Italy.
- Forlines et al., "Glimpse: a Novel Input Model for Multi-level Devices," CHI 2005, Apr. 2-7, 2005, 4 pages, ACM, Portland, OR.
- Forlines et al., "HybridPointing: Fluid Switching Between Absolute and Relative Pointing with a Direct Input Device," UIST '06, Oct. 15-18, 2006, pp. 211-220, ACM, Montreux, Switzerland.
- Forlines et al., "Improving Visual Search With Image Segmentation," CHI 2009 Proceedings: Visualization 1, Apr. 4-9, 2009, pp. 1093-1102, ACM, Boston, Massachusetts.
- Forlines et al., "Multi-User, Multi-Display Interaction with a Single-User, Single Display Geospatial Application," ACM Symposium on User Interface Software and Technology, Oct. 2006, 5 pages, Mitsubishi Electric Research Laboratories, Inc., Cambridge, MA.
- Forlines et al., "Under MY Finger: Human Factors in Pushing and Rotating Documents Across the Table," INTERACT 2005, Dec. 2005, 5 pages, Mitsubishi Electric Research Laboratories, Inc., Cambridge, MA.
- Forlines, "Exploring the Effects of Group Size and Display Configuration on Visual Search," CSCW '06, Nov. 4-8, 2006, pp. 11-20, ACM, Banff, Alberta, CA.
- Forlines, "Zoom-and-Pick: Facilitating Visual Zooming and Precision Pointing with Interactive Handheld Projectors," UIST '05, Oct. 23-27, 2005, pp. 73-82, ACM, Seattle, Washington.
- Fowler et al., UML Distilled, Second Edition, A Brief Guide to the Standard Object Modeling Language, 2000, 213 pages, Addison-Wesley, Canada.
- Foxlin et al., "Constellation: A Wide-Range Wireless Motion-Tracking System for Augmented Reality and Virtual Set Applications," Proceedings of SIGGRAPH 98, Jul. 9-24, 1998, 8 pages, InterSense Incorporated.
- Fryberger et al., "An Innovation in Control Panels for Large Computer Control Systems," 4 pages, Stanford University, Stanford, CA [no date available].
- Fukuchi et al., "Interaction Techniques for SmartSkin," 2 pages [no date available].
- Fukuchi et al., "Marble Market: Bimanual Interactive Game with a Body Shape Sensor," journal, date, and publication information unknown, 8 pgs. [no date available].
- Fukuchi et al., "Massively Parallel Manipulation Techniques with SmartSkin," —Not in English, 2 pages [no date available].
- Fukuchi et al., "SmartSkin," —(Only summary in English), 5 pages [no date available].
- Fukuchi, "Concurrent Manipulation of Multiple Components on Graphical User Interface," Oct. 23, 2006, 160 pages.
- Fukuchi, "Multi-Track Scratch Player on a Multi-Touch Sensing Device," journal, date, and publication information unknown, 8 pgs.

(56)

References Cited

OTHER PUBLICATIONS

- Furuichi et al., "DTMap Demo: Interactive Tabletop Maps for Ubiquitous Computing," UbiComp 2005, Sep. 2005, 3 pages, Mitsubishi Electric Research Laboratories, Inc., Cambridge, MA.
- Gamma et al., "Design Patterns Elements of Resusable Object-Oriented Software," 1995, 397 pages, Addison-Wesley Longman, Inc., Reading, MA.
- Gaver et al., "Realizing a Video Environment: EuroPARC's RAVE System," Proceedings of the CHI '92 Conference on Human Factors in Computing Systems, May 3-7, 1992, pp. 27-35, Association for Computing Machinery, New York.
- Gellersen et al., "An Evaluation of Techniques for Reducing Spatial Interference in Single Display Groupware," Proceedings of the Ninth European Conference on Computer-Supported Cooperative Work, 2005, 20 pages, Paris France.
- Gillespie, "Novel Touch Screens for Hand-Held Devices," BPA International, vol. 18, No. 2, Feb. 2002, 5 pages, SID.
- Gingold et al., "A Direct Texture Placement and Editing Interface," UIST'06, Oct. 15-18, 2006, 9 pages, ACM, Montreux, Switzerland.
- Gleicher, "Image Snapping," 1995, 8 pages, ACM.
- Google Earth, "GoogleEarth API Information," Nov. 2005, 3 pages, <http://markmail.org/message/xaz63x7agpskhy4h>.
- Google Earth, "IApplicationGE Interface Reference," 2011, 11 pages, <http://web.archive.org/web/20061010071219/http://earth.google.com/comapi/interfac...>
- Google Earth, "Navigating in Google Earth Google Earth Help," 2011, 23 pages, <http://earth.google.com/support/bin/static.py?page=guide.cs&guide=22358&topic=22...>
- Google, "Nexus One," User's Guide, Mar. 15, 2010, 334 pages.
- Gosling et al., "The Java Language Specification Third Edition," 1996, 670 pages, Addison-Wesley, Upper Saddle River, NJ.
- Graham et al., "Communicating Sequential Processes," Communications of the ACM, vol. 21, No. 8, 1978, 12 pages, ACM, Oxford, England.
- Graham et al., "Physical Versus Virtual Pointing," CHI 96, Apr. 13-18, 1996, 8 pages, ACM, Vancouver, BC, Canada.
- Greenberg et al., "Usability Evaluation Considered Harmful (Some of the Time)," CHI 2008 Proceedings: Usability Evaluation Considered Harmful?, Apr. 5-10, 2008, pp. 111-120, ACM, Florence, Italy.
- Greene, "Audio Menus for Ipods," Technology Review, May 8, 2007, 2 pgs., <http://www.dgp.toronto.edu/~ravin/press/MIT-TechReview20070508.htm>[Sep. 14, 2011 12:39:27 PM].
- Gross, "Grids in Design and CAD," 11 pages, University of Colorado, Boulder, CO [no date available].
- Grossman et al., "A Probabilistic Approach to Modeling Two-Dimensional Pointing," ACM Transactions on Computer-Human Interaction, vol. 12, No. 3, Sep. 2005, 25 pages, University of Toronto.
- Grossman et al., "An Evaluation of Depth Perception on Volumetric Displays," AVI '06, May 23-26, 2006 8 pages, ACM, Venezia, Italy.
- Grossman et al., "An Interface for Creating and Manipulating Curves Using a High Degree-of-Freedom Curve Input Device," CHI 2003, Apr. 5-10, 2003, 8 pages, Ft. Lauderdale, FL, USA.
- Grossman et al., "Collaborative Interaction with Volumetric Displays," CHI 2008 Proceedings—Collaborative User Interfaces, pp. 383-392, Florence, Italy, Apr. 5-10, 2008.
- Grossman et al., "Creating Principal 3D Curves With Digital Tape Drawing," CHI 2002, Apr. 20-25, 2002, 8 pgs., ACM, Minneapolis, MN.
- Grossman et al., "Exploring and Reducing the Effects of Orientation on Text Readability in Volumetric Displays," CHI 2007 Proceedings: Innovative Interactions, Apr. 28-May 3, 2007, pp. 483-492, ACM, San Jose, California.
- Grossman et al., "Hover Widgets: Using the Tracking State to Extend the Capabilities of Pen-Operated Devices," CHI 2006 Proceedings: Pen, Apr. 22-27, 2006, pp. 861-870, ACM, Montreal, Quebec, Canada.
- Grossman et al., "Interaction Techniques for 3D Modeling on Large Displays," Proceedings of the ACM Symposium on Interactive 3D Graphics (I3DG2001), 2001, pp. 17-23, ACM.
- Grossman et al., "Modeling Pointing at Targets of Arbitrary Shapes," CHI 2007 Proceedings: Innovative Interactions, Apr. 28-May 3, 2007, pp. 463-472, ACM, San Jose, California.
- Grossman et al., "Multi-Finger Gestural Interaction with 3D Volumetric Displays," UIST '04, Oct. 24-27, 2004, 10 pages, ACM.
- Grossman et al., "Once More, With Volume," Technology Review Synopses, Feb. 2005, pp. 82-83.
- Grossman et al., "Pointing at Trivariate Targets in 3D Environments," CHI 2004, 8 pages, ACM, Vienna, Austria, Apr. 24-29, 2004.
- Grossman et al., "Strategies for Accelerating On-Line Learning of Hotkeys," CHI 2007 Proceedings: Learning, Apr. 28-May 3, 2007, pp. 1591-1600, ACM, San Jose, California.
- Grossman et al., "The Bubble Cursor: Enhancing Target Acquisition by Dynamic Resizing of the Cursor's Activation Area," CHI 2005, Apr. 2-7, 2005, 10 pages, ACM, Portland, OR.
- Grossman et al., "The Design and Evaluation of Selection Techniques for 3D Volumetric Displays," UIST '06, Oct. 15-18, 2006, pp. 3-12, ACM, Montreux, Switzerland.
- Gujar et al., "Talking Your Way Around a Conference: A speech interface for remote equipment control," 7 pages, University of Toronto, Toronto, Ontario, Canada [no date available].
- Han et al., "Measuring Bidirectional Texture Reflectance with a Kaleidoscope," 2003, 8 pages, ACM.
- Han et al., "Multi-Touch Interaction Research Animation Theater," Computer Animation Festival, 1 page, New York University [no date available].
- Han, "Low-Cost Multi-Touch Sensing through Frustrated Total Internal Reflection," UIST'05, Oct. 23-27, 2005, 4 pages, ACM, Seattle, WA.
- Han, "Media Mirror," 1 page, Media Research Laboratory, New York University [no date available].
- Han, "Multi-Touch Interaction Wall," 1 page, Courant Institute of Mathematical Sciences, New York University [no date available].
- Han, "Multi-Touch Sensing through Frustrated Total Internal Reflection," 1 page, Media Research Laboratory, New York University [no date available].
- Han, "Profile on Jeff Han," 2011, 18 pages, <http://cs.nyu.edu/~jhan/mediamirror/index/html>.
- Han, "Unveiling the Genius of Multi-Touch Interface Design," Video on TED.com, TED ideas worth spreading, 2009, 3 pages, http://www.ted.com/index.php/talks/jeff_han_demos_his_breakthrough_touchscreen.html.
- Hancock et al., "Exploring Non-Speech Auditory Feedback at an Interactive Multi-User Tabletop," Graphic Interface 2005, May 2005, 11 pages, Mitsubishi Electric Research Laboratories, Inc., Cambridge, MA.
- Hansen et al., "Events Not Equal To GUIs," SIGCSE '04, Mar. 3-7, 2004, 4 pages, ACM, Norfolk, VA.
- Hardock et al., "A Marking Based Interface for Collaborative Writing," Proceedings of UIST '93, 1993, pp. 259-266 [<http://www.billbuxton.com/Mate.html>].
- Harrison et al., "Squeeze Me, Hold Me, Tilt Me! An Exploration of Manipulative User Interfaces," CHI '98, Apr. 18-23, 1998, 8 pages, Los Angeles, CA.
- Harrison et al., "Transparent Layered User Interfaces: An Evaluation of a Display Design to Enhance Focused and Divided Attention," Proceedings of the ACM Conference on Human Factors in Computing Systems (CHI '95), 1995, pp. 317-324, ACM, New York [<http://www.billbuxton.com/transparency.html>].
- Hauptmann et al., "Gesture Analysis for Graphic Manipulation," Nov. 28, 1988, 19 pages.
- Helms, "Virtual Environment Technology for MOUT Training," Jul. 1997, 164 pages, Navy Personnel Research and Development Center, San Diego, CA.
- Henault et al., "A Computer Simulation Study and Component Evaluation For A Quaternion Filter For Sourceless Tracking Of Human Limb Segment Motion," Mar. 1997, 107 pages.
- Henning et al., "Advanced COBRA Programming with C++," 1999, 1091 pages, Addison-Wesley Longman, Inc., Reading, MA.
- Herot et al., "One-Point Touch Input of Vector Information for Computer Displays," 7 pages, Massachusetts Institute of Technology, Cambridge, MA [no date available].

(56)

References Cited

OTHER PUBLICATIONS

- Hewlett-Packard, "QuickSpecs for HP iPAQ rx 1950 Pocket PC Product Information," Hewlett-Packard Development Co., L.P., Sep. 26, 2005, 9 pgs.
- Hilbert et al., "Extracting Usability Information from User Interface Events," ACM Computing Surveys, Dec. 2000, pp. 384-421, vol. 32, No. 4.
- Hinckley et al., "Codex: A Dual Screen Tablet Computer," CHI 2009 Proceedings: New Mobile Interactions, Apr. 4-9, 2009, pp. 1933-1942, ACM, Boston, Massachusetts.
- Hinckley et al., "Sensing Techniques for Mobile Interaction," UIST 2000, 2000, 10 pages, ACM, Redmond, WA.
- Hinckley et al., "Touch-Sensing Input Devices," CHI 99, May 15-20, 1999, 8 pages, ACM, Pittsburgh, PA.
- Hinckley, et al., "Quantitative Analysis of Scrolling Techniques," Conf. on Human Factors in Computing Systems, Apr. 20-25, 2002, pp. 65-72, vol. 4, No. 1, CHI Letters, Redmond, WA.
- Hinrichs et al., "Evaluating the Effects of Fluid Interface Components on Tabletop Collaboration," Proceedings of the International Working Conference on Advanced Visual Interfaces (AVI) '06, May 22-26, 2006, 8 pgs., ACM.
- Hinrichs et al., "Interface Currents: Supporting Fluid Face-to-Face Collaboration," CSCW 06, 2006, 1 pg., Banff, Alberta, Canada.
- Hinrichs et al., "Interface Currents: Supporting Fluent Collaboration on Tabletop Displays," 12 pages, Otto-von-Guericke University, Magdeburg, Germany [no date available].
- Hinrichs et al., "Interface Currents: Supporting Fluent Face-to-Face Collaboration," 1 page, Otto-von-Guericke University, Magdeburg, Germany, Nov. 4-8, 2006.
- Hoff et al., "Computer vision-based registration techniques for augmented reality," Proceedings of Intelligent Robots and Computer Vision XV, SPIE, vol. 2904, Nov. 18-22, 1996, 10 pages, Boston, MA.
- Holloway et al., "Virtual Environments: A Survey of the Technology," Sep. 1993, 59 pages, University of North Carolina at Chapel Hill, Chapel Hill, NC.
- Houde, "Iterative Design of an Interface for Easy 3-D Direct Manipulation," CHI '92, May 3-7, 1992, 8 pages, ACM.
- HP invent, "User's Guide, hp iPAQ Pocket PC h1900 series, Models: h1930, h1935, h1937, h1940, h1945," First Edition, May 2003, 128 pages.
- HTC, "HTC HD2," User Manual, 2009, 301 pages.
- HTC, "HTC Tilt 2," User Manual, 2010, 277 pages.
- HTC, "myTouch 4G Slide," User Guide, 2011, 176 pages.
- HTC, "Touch Cruise," User Manual, 2009, 318 pages.
- HTC, "Touch Pro," Quick Start Guide, 41 pages, [no date available].
- HTC, "Touch Pro," User Manual, 2008, 160 pages.
- HTC, "Touch Pro," User Manual, 2008, 164 pages.
- HTC, "Your HTC 7 Pro," Quick Guide, 2 pages, [no date available].
- HTC, "Your HTC 7 Pro," User Guide, 2011, 74 pages.
- HTC, "Your HTC 7 Trophy," Quick Guide, 2 pages, [no date available].
- HTC, "Your HTC 7 Trophy," User Guide, 2010, 78 pages.
- HTC, "Your HTC Amaze 4G," User Guide, 204 pages.
- HTC, "Your HTC Freestyle," User Guide, 2011, 90 pages.
- HTC, "Your HTC HD7," User Guide, 2010, 78 pages.
- HTC, "Your HTC HD7S," User Guide, 2011, 79 pages.
- HTC, "Your HTC Jetstream," User Guide, 2011, 174 pages.
- HTC, "Your HTC Radar 4G," Quick Guide, 2 pages, [no date available].
- HTC, "Your HTC Radar 4G," User Guide, 2011, 102 pages.
- HTC, "Your HTC Radar 4G," User Guide, 2011, 103 pages.
- HTC, "Your HTC Rhyme," User Guide, 2011, 342 pages.
- HTC, "Your HTC Sensation 4G," User Guide, 191 pages, [no date available].
- HTC, "Your HTC Status," User Guide, 2011, 179 pages.
- HTC, "Your HTC Surround," User Guide, 2010, 79 pages.
- HTC, "Your HTC Titan," User Guide, 2011, 101 pages.
- HTC, "Your HTC Vivid," User Guide, 2011, 199 pages.
- HTC, "Your HTC Wildfire S," Quick Guide, 2 pages, [no date available].
- HTC, "Your HTC Wildfire S," User Guide, 2011, 175 pages.
- Hudson et al., "Animation Support in a User Interface Toolkit: Flexible, Robust, and Reusable Abstractions," Graphics Visualization and Usability Center, College of Computing, 10 pages, Georgia Institute of Technology, Atlanta, GA [no date available].
- Huey et al., "Communication Arts," vol. 46, No. 5, Sep./Oct. 2004, 215 pages.
- IBM Retail Store Solutions, "Noise Frequencies in Capacitive Touch Screens," 8 pages [no date available].
- IBM, "Method to Disable and Enable a Touch Pad Pointing Device or Tablet Input Device using Gestures," Jun. 11, 2002, 4 pages, IP.com.
- Imserba, "Mobile Applications Software," Scribble UIQ, accessed at <http://www.imserba.com/forum/scribble-uiq-t57435/>, Oct. 7, 2011, 2 pages.
- Integrated—Google Search, Dictionary "in-te-grat-ed," 2 pages <https://www.google.com/search?source=jg&hl=en&rlz-&q=define+integr...> [no date available].
- International Search Report and Written Opinion of the International Searching Authority, dated Jun. 11, 2008, The United States Patent and Trademark Office for International Application No. PCT/US2006/061337.
- Internet.com, "Flash Kit," A Flash Developer Resource Site, 3 page [no date available].
- Internet.com, "Teleprompter—VPForums," VBWire, Oct. 10, 2011, 14 page, accessed at <http://www.vbforums.com/showthread.php?t=244139>.
- Intuilab, "ANIMS CARE-INO: State of the art on sound and animations in Human Machine Interfaces," Sep. 2004, 36 pages, EUROCONTROL.
- Ishak et al., "Content-Aware Scrolling," UIST '06, Oct. 15-18, 2006, 4 pages, ACM, Montreux, Switzerland.
- Ivanov et al., "Tracking People in Mixed Modality Systems," VCIP 2007, Feb. 2007, 12 pages, Mitsubishi Electric Research Laboratories, Inc., Cambridge, MA.
- Izadi et al., "A Thin Form-Factor Interactive Surface Technology," Communications of the ACM, Dec. 2009, pp. 90-98, vol. 52, No. 12.
- Izadi et al., "ThinSight: Integrated Optical Multi-Touch Sensing Through Thin Form-Factor Displays," EDT 2007, 2007, 4 pgs., The Association for Computing Machinery, San Diego, CA.
- Java Community Process, "Mobile Information Device Profile for JAVA 2 Micro Edition," 1999, 566 pages, Sun Microsystems, Inc., Palo Alto, CA.
- Jiang et al., "DiamondTouch," 2009, 4 pages, Mitsubishi Electric Research Laboratories, Cambridge, MA.
- Jiang et al., "LivOlay: Interactive Ad-Hoc Registration and Overlapping of Applications for Collaborative Visual Exploration," CHI 2008, Aug. 2008, 5 pages, Mitsubishi Electric Research Laboratories, Inc., Cambridge, MA.
- Johnson et al., "A Collection of Papers from FirstPerson, Inc.," Aug. 1995, 91 pages, Sun Microsystems Laboratories, Mountain View, CA.
- Johnson et al., "The Effect of Touch-Pad Size on Pointing," FirstPerson Technical Report FP-1994-2, Apr. 1994, 10 pages, Sun Microsystems, Inc., Mountain View, CA.
- Johnson, "A Comparison of User Interfaces for Panning on a Touch-Controlled Display," CHI '95, May 7-11, 1995, 8 pages, ACM, Denver, CO.
- Johnson, "Gestures redefine computer interface," Oct. 21, 1996, 1 page, Electronic Engineering Times.
- Johnson, "Touch Displays: A Programmed Man-Machine Interface," Ergonomics Research Society, vol. 10, No. 2, Mar. 1967, 8 pages, Taylor & Francis Ltd., London.
- Kabbash et al., "Human Performance Using Computer Input Devices in the Preferred and Non-Preferred Hands," Proceedings of the INTERCHI '93 Conference on Human Factors in Computing Systems, 1993, pp. 474-481, Association for Computing Machinery, New York [<http://www.billbuxton.com/LHfitts.html>].
- Kabbash et al., "The 'Prince' Technique: Fitts' Law and Selection Using Area Cursors," Proceedings of the ACM Conference on Human Factors in Computing Systems (CHI '95), 1995, pp. 273-279, ACM, New York [<http://www.billbuxton.com/prince.html>].

(56)

References Cited

OTHER PUBLICATIONS

- Kabbash et al., "Two-Handed Input in a Compound Task," Proceedings of CHI '94, 1994, 10 pages, <http://www.billbuxton.com/2hCHI94.html>.
- Kamba et al., "Using Small Screen Space More Efficiently," CHI 96, Apr. 13-18, 1996, 8 pages, ACM Vancouver, BC, Canada.
- Karlson et al., "AppLens and Launch Tile: Two Designs for One-Handed Thumb Use on Small Devices," Article, 10 pages, Human-Computer Interaction Lab, University of Maryland, [no date available].
- Karlson et al., "AppLens and Launch Tile: Two Designs for One-Handed Thumb Use on Small Devices," PowerPoint Presentation, 34 pages, Human-Computer Interaction Lab, University of Maryland, [no date available].
- Karlson et al., "AppLens and Launch Tile: Two Designs for One-Handed Thumb Use on Small Devices," PowerPoint Presentation with notes, 50 pages, Human-Computer Interaction Lab, University of Maryland [no date available].
- Kasik et al., "Ten CAD Challenges," 2005, 12 pages, IEEE Computer Society.
- Kawachiya et al., "NaviPoint: An Input Device for Mobile Information Browsing," CHI '98, Apr. 18-23, 1998, 8 pages, Los Angeles, CA.
- Kawamoto, "The History of Liquid-Crystal Displays," Apr. 2002, pp. 460-500, Proceedings of the IEEE, vol. 90, No. 4.
- Keelan et al., "An Analysis of the Human Papilloma Virus Vaccine Debate on MySpace Blogs," Elsevier, 2010, pp. 1535-1540, 2009 Elsevier Ltd.
- Keskin et al., "Real Time Hand Tracking and 3D Gesture Recognition For Interactive Interfaces Using HMM," 4 pages, Computer Engineering Dept. Bogazici University [no date available].
- Kim et al., "Multi-Touch Interaction for Table-Top Display," ICAT 2006, 2006, pp. 1273-1282, Springer-Verlag, Berlin, Heidelberg.
- Kirk, "Optimal Control Theory," 1970, 15 pages, Prentice-Hall, Inc., Englewood Cliffs, NJ.
- Kitamura et al., "Music Synthesis by Simulation using a General-Purpose Signal Processing System," ICMC '85 Proceedings, 1985, 4 pages, University of Toronto.
- Kitchin, "Using Accelerometers in Low g Applications," 6 pages, Analog Devices, Norwood, MA [no date available].
- Kobayashi, "Design of dynamic soundscape: mapping time to space for audio browsing with simultaneous listening," 1996, 58 pages, Massachusetts Institute of Technology, MA.
- Korpela, "Using inline frames to embed documents into HTML documents," 2011, 10 pages, <http://www.cs.tut.fi/~jkorpela/html/iframe.html>.
- Krein et al., "The Electroquasistatics of the Capacitive Touch Panel," IEEE Transactions on Industry Applications, May/June 1990, pp. 529-534, vol. 26, No. 3, Pittsburgh, PA.
- Krolik, "PIV Creator 3.41—Cross Browser DHTML 360° Panorama Image Viewer (PIV)," 3 pages, 1999-2006, Martin Krolik.
- Krueger et al., "Videoplacement—An Artificial Reality," CHI '85 Proceedings, 1985, 6 pages, University of Connecticut.
- Krueger, "Artificial Reality II," 1991, 320 pages, Addison-Wesley Publishing Company, Inc., Reading, MA —.
- Krueger, "Artificial Reality," 1983, 328 pages, Addison-Wesley Publishing Company, Reading, MA.
- Kruger et al., "Fluid Integration of Rotation and Translation," Proceedings of the ACM Conference on Human Factors in Computing Systems, Apr. 2-7, 2005, 10 pages, Portland, OR.
- Kruger, et al., "How People Use Orientation on Tables: Comprehension, Coordination and Communication," [no date], 10 pages, Univ. of Calgary, Department of Science, Calgary, Alberta.
- Kumar et al., "Gaze-Enhanced Scrolling Techniques," UIST '07, Oct. 7-10, 2007, 4 pgs., ACM, Newport, Rhode Island.
- Kurlansky et al., "Communication Arts," vol. 45, No. 5, Sep./Oct. 2003, 208 pages.
- Kurtenbach et al., "An Empirical Evaluation of Some Articulatory and Cognitive Aspects of 'Marking Menus,'" Human Computer Interaction, 1993, pp. 1-23, vol. 8, No. 1 [<http://www.billbuxton.com/PieMenus.html>].
- Kurtenbach et al., "Contextual Animation of Gestural Commands," Computer Graphics Forum, 1994, vol. 13, No. 5, 10 pages, Blackwell Publishers, Oxford, UK.
- Kurtenbach et al., "GEdit: A Test Bed for Editing by Continuous Gestures," SIGCHI Bulletin, 1991, pp. 22-26, vol. 23, No. 2 [<http://www.billbuxton.com/GEditBulletin.html>].
- Kurtenbach et al., "Issues in Combining Marking and Direct Manipulation Techniques," Proceedings of the Fourth ACM SIGGRAPH Symposium on User Interface Technology (UIST), 1991, pp. 137-144 [<http://www.billbuxton.com/GEdit.html>].
- Kurtenbach et al., "The Design of a GUI Paradigm based on Tablets, Two-Hands, and Transparency," CHI 97, 1997, 8 pages, ACM, Atlanta, GA.
- Kurtenbach et al., "The Limits of Expert Performance Using Hierarchic Marking Menus," Proceedings of the InterCHI '93, 1993, 7 pages, University of Toronto.
- Kurtenbach et al., "User Learning and Performance with Marking Menus," Proceedings of CHI '94, 1994, 11 pages, <http://www.billbuxton.com/MMUserLearn.html>.
- Laurel et al., "The Art of Human-Computer Interface Design," 1990, 552 pages, Addison-Wesley Publishing Company, Inc.
- Laurel, "The Art of Human-Computer Interface Design," 1990, 19 pages, Addison-Wesley.
- Lavoisier Librairie, "Designing interfaces: Patterns for effective interaction design," Dec. 2005, 2 pages, <http://www.lavoisier.fr/livre/notice.asp?id=OA6WXOAO2OWF>.
- Lecaine, "Biography," 2011, 130 pages, <http://www.hughlecaine.com/en/biography.html>.
- Lee et al., "A Multi-Touch Three Dimensional Touch-Sensitive Tablet," CHI '85 Proceedings, Apr. 1985, 5 pages, University of Toronto.
- Lee et al., "Haptic Pen: Tactile Feedback Stylus for Touch Screens," ACM Symposium on User Interface Software and Technology, Oct. 2004, 5 pages, Mitsubishi Electric Research Laboratories, Inc., Cambridge, MA.
- Lee, "A Fast Multiple-Touch-Sensitive Input Device," Oct. 1984, 120 pages, University of Toronto.
- Leeper, "14.2: Integration of a Clear Capacitive Touch Screen with a 1/8-VGA FSTN-LCD to form and LCD-based TouchPad," 2002, pp. 187-189, SID 02 Digest, Synaptics, Inc., San Jose, CA, USA.
- Leganchuk et al., "Manual and Cognitive Benefits of Two-Handed Input: An Experimental Study," Transactions on Human-Computer Interaction, 1998, pp. 326-359, vol. 5, No. 4 [<http://www.billbuxton.com/ToCHI2H.html>].
- Lesh et al., "Building and Sharing Digital Group Histories," ACM Conference on Computer Supported Cooperative Work, Nov. 2002, 11 pages, Mitsubishi Electric Research Laboratories, Inc., Cambridge, MA.
- Levin et al., "Bringing Sketching Tools to Keychain Computers with an Acceleration-Based Interface," 2 pages, MIT Media Laboratory, Cambridge, MA [no date available].
- Lewis et al., "MAC OS in a Nutshell," 2000, 403 pages, O'Reilly & Associates, Inc., Sebastopol, CA.
- Leydon et al., "Gesture-Based Control of a Personal Digital Assistant," Mar. 6, 2001, 121 pages, Dartmouth College.
- Lieberman, "PowerPC 603e rides VMEbus boards," Jul. 24, 1995, 1 page, Electronic Engineering Times.
- Lindholm et al., "The Java™ Virtual Machine Specification," Second Edition, 1997, 489 pages, Addison-Wesley.
- Linus Technologies, Inc., "Linus Write-Top computer, 2012, 7 pages, <http://oldcomputers.net/linus.html>.
- Lippman, "C# Primer A Practical Approach," 2002, 413 pages, Addison-Wesley, Boston, MA.
- Lueder, "Liquid Crystal Displays, Addressing Schemes and Electro-Optical Effects," 2001, 5 pages, John Wiley & Sons, Ltd., West Sussex, England.
- MacIntyre et al., "Future Multimedia User Interfaces," 1996, 26 pages, Multimedia Systems.

(56)

References Cited

OTHER PUBLICATIONS

- MacKay et al., "Reinventing the Familiar: Exploring an Augmented Reality Design Space for Air Traffic Control," 8 pages, France [No Date Available].
- MacKenzie et al., "A Comparison of Input Devices in Elemental Pointing and Dragging Tasks," Proceedings of the CHI '91 Conference on Human Factors in Computing Systems, 1991, pp. 161-166, Association for Computing Machinery, New York.
- MacKenzie et al., "A Comparison of Three Selection Techniques for Touchpads," CHI 98, 1998, 8 pages, Los Angeles, CA.
- MacKenzie et al., "Extending Fitts' Law to Two-Dimensional Tasks," Proceedings of the CHI '92 Conference on Human Factors in Computing Systems, 1992, pp. 219-226, Association for Computing Machinery, New York.
- MacKenzie et al., "The Prediction of Pointing and Dragging Times in Graphical User Interfaces," Interacting with Computers, 1994, 12 pages, <http://www.billbuxton.com/TCW.html>.
- Malik et al., "Interacting with Large Displays from a Distance with Vision-Tracked Multi-Finger Gestural Input," UIST'05, 2005, 10 pages, ACM, Seattle, WA.
- Malik et al., "Visual Touchpad: A Two-handed Gestural Input Device," ICMI'04, 2004, 8 pages, ACM, Pennsylvania, USA.
- Malik, "An Exploration of Multi-Finger Interaction on Multi-Touch Surfaces," Doctoral Thesis, Graduate Dept. of Computer Science, University of Toronto, 2007, 184 pgs.
- Mantei et al., "Experiences in the Use of a Media Space," [Publication Unknown], 1991, pp. 203-208, Association for Computing Machinery, New York.
- Martin, "Snaky Tape May Enliven Computer Interactions," NewsFactor Network, Apr. 21, 2003, 2 pages, NewsFactor Sci.:Tech, Tech Innovation & Discovery, <http://sci.newsfactor.com/perl/story/21314.html>.
- Masui et al., "Elastic Graphical Interfaces for Precise Data Manipulation," ACM Conference on Human Factors in Computing Systems (CHI'95) Conference Companion (Apr. 1995), ACM Press, pp. 143-144.
- Matias et al., "Half-QWERTY: A One-Handed Keyboard Facilitating Skill Transfer From QWERTY," Proceedings of the INTERCHI '93 Conference on Human Factors in Computing Systems, 1993, pp. 88-94, Association for Computing Machinery, New York [<http://www.billbuxton.com/matias93.html>].
- Matias et al., "Half-QWERTY: Typing With One Hand Using Your Two-handed Skills," Companion of the CHI '94 Conference on Human Factors in Computing Systems, 1994, 3 pages, ACM, NY.
- Matias et al., "One-Handed Touch-Typing on a QWERTY Keyboard," Human-Computer Interaction, 1996, pp. 1-27, vol. 11, Lawrence Erlbaum Associates, Inc.
- McDaniel, "IBM Dictionary Of Computing," Aug. 1993, 3 pages, McGraw-Hill, Inc., New York.
- McGuffin et al., "Acquisition of Expanding Targets," Paper: Smooth Moves, Apr. 20-25, 2002, pp. 57-64, vol. 4, No. 1, Minneapolis, MN USA.
- McGuffin et al., "Expand-Ahead: A Space-Filling Strategy for Browsing Trees," 8 pages, University of Toronto [no date available].
- McGuffin et al., "Fitts' Law and Expanding Targets: Experimental Studies and Designs for User Interfaces," ACM Transactions on Computer-Human Interaction, vol. 12, No. 4, Dec. 2005, pp. 388-422.
- McGuffin et al., "Interactive Visualization of Genealogical Graphs," 8 pages, University of Toronto [no date available].
- McGuffin, et al., "Using Deformations for Browsing Volumetric Data," Oct. 19-24, 2003, pp. 401.408, IEEE Visualization, Seattle, Washington, USA.
- Mehta, "A Flexible Human Machine Interface," Oct. 1982, 82 pages.
- Mertz et al., "Pushing the limits on aTC user interface design beyond S&M interaction: the DigiStrips experience," 3rd USA/Europe Air Traffic Management R&D Seminar, Jun. 13-16, 2000, 9 pages, Napoli.
- Mertz et al., "The influence of design techniques on user interfaces" the DigiStrips experiment for air traffic control, HCI-aero Sep. 2000, 2000, 7 pages, Toulouse, France.
- Mertz, "ANIMS, CARE-INO projet Identification of operational scenarios for sound and animations use in ATC.," Sep. 2004, 24 pages, EUROCONTROL.
- Mertz, "Peripheral awareness offered by interaction techniques in Air Traffic Control interfaces," CHI 2003, 2003, 4 pages, Toulouse, France.
- Mertz, "Touch Input and Animations: More Efficient and Humanized Computer Interactions for ATC(O)," Proceedings of the 10th International Symposium on Aviation Psychology, 1999, 6 pages, Columbus, OH.
- Mertz, "Users Bandwidth in Air Traffic Management: an Analysis from the HMI Point of View," HCI-02 Proceedings, 2002, 6 pages, American Association for Artificial Intelligence.
- Meyer, "An Integrated Capacitive Position Sensor," Proceedings Integrating Intelligent Instrumentation and Control, IEEE Xplore, Apr. 23-25, 1995, 1 page.
- Microsoft, "Computer Dictionary," Fifth Edition, 2002, 651 pages, Microsoft Press, Redmond, WA.
- Microsoft, "Computer Dictionary," Third Edition, 1997, 561 pages, Microsoft Press, Redmond, WA.
- Minsky et al., "Manipulating Simulated Objects with Real-world Gestures using a Force and Position Sensitive Screen," Computer Graphics, Jul. 1984, vol. 18, No. 3, 9 pages.
- Moghaddam et al., "Visualization & User-Modeling for Browsing Personal Photo Libraries," International Journal of Computer Vision 56(1/2), Feb. 2004, 34 pages, Mitsubishi Electric Research Laboratories, Inc., Cambridge, MA.
- Monster Tracks, "Original Music Downloads," 2011, 46 pages, <http://www.monstertracks.com/mtFILES/freemusicdownload.html>.
- Montalbano, "Novell Launches next-generation Linux desktop," Mar. 9, 2006, 4 pages, ComputerWorld.
- Moraveji et al., "A Mischief of Mice: Examining Children's Performance in Single Display Groupware Systems with 1 to 32 Mice," CHI 2009 Proceedings: Systems for Children, Apr. 9, 2009, pp. 2157-2166, ACM, Boston, Massachusetts.
- Morgan, "New Enterprise-Class Linux Desktop Previewed by Novell," Mar. 14, 2006, 2 pages, <http://www.itjungle.com/sub/subscribe.html>.
- Morgan, "Novell Betas XGL 3D Graphics for Linux Desktop," The Linux Beacon, vol. 3, No. 5, Feb. 7, 2006, 2 pages.
- Morris et al., "Beyond Social Protocols: Multi-User Coordination Policies for Co-located Groupware," Jan. 2004, 6 pages, CSCW, Mitsubishi Electric Research Laboratories, Inc., Cambridge, MA.
- Morris et al., "Conflict Resolution in Paper and Digital Worlds: Two Surveys of User Expectations," CSCW, Jan. 2004, 4 pages, Mitsubishi Electric Research Laboratories, Inc., Cambridge, MA.
- Moscovich et al., "A Multi-finger Interface for Performance Animation of Deformable Drawings," 2 pages, Brown University [no date available].
- Moscovich et al., "Multi-finger Cursor Techniques," 7 pages, Department of Computer Science, Providence, RI [no date available].
- Moscovich, "Principles and Applications of Multi-Touch Interaction," Doctoral Dissertation, Department of Computer Science, Brown University, 2007, 114 pgs., Providence, Rhode Island.
- Moyle et al., "The Design and Evaluation of a Flick Gesture for 'Back' and 'Forward' in Web Browsers," 8 page, Human-Computer Interaction Lab, Christchurch, Department of Computer Science, New Zealand, 2002, Australia Computer Society, Inc.
- MSDN, "Control OnPaint Method," 2011, 4 pages, <http://www.msdn.microsoft.com/en-us/library/systems.windows.forms.control.onpaint>.
- MSDN, "SendInput function," 2011, 7 pages, [http://www.mdn.microsoft.com/en-us/library/ms646310\(d=printer\)](http://www.mdn.microsoft.com/en-us/library/ms646310(d=printer)).
- My-Symbian.com, "Orange Scribble", OrangeScribble for UIQ 2x by Orange:: Symbian software @ My-Symbian.com, accessed at <http://my-symbian.com/uiq/software/applications/php?fldAuto=638,faq=6>, Oct. 7, 2011, 2 pages.
- Myers et al., "Past, Present, and Future of User Interface Software Tools," ACM Transactions on Computer-Human Interaction, vol. 7, No. 1, 2000, 26 pages, ACM.

(56)

References Cited

OTHER PUBLICATIONS

- Myers et al., "Creating Highly-Interactive and Graphical User-Interfaces by Demonstration," SIGGRAPH '86, Aug. 18-22, 1986, vol. 20, No. 4, 10 pages, Dallas, TX.
- Nakatani et al., "Soft Machines: A Philosophy of User-Computer Interface Design," Dec. 1983, pp. 19-23, Addison-Wesley Publishing Company.
- Narayanaswamy et al., "User Interface for a PCS Smart Phone," 1999, 5 pages, IEEE, [no date available].
- Narine et al., "Collaboration Awareness and Its Use to Consolidate a Disperse Group," Proceedings of Interact '97, 1997, 12 pgs., Sydney, Australia [http://www.billbuxton.com/postcards.html].
- Nasiri et al., "Motion Processing: The Next Breakthrough Function in Handsets," 10 pages, InvenSense, Inc., Sunnyvale, CA [no date available].
- Newman, "A system for interactive graphical programming," Spring Joint Computer Conference, 1968, 8 pages, Harvard University, Cambridge, MA.
- Newton, "Apple Message Pad Handbook," 1995, 196 pages, Apple Computer, Inc., Cupertino, CA.
- Next-Generation Sharp Organiser to Carry Pen Interface, Jul. 1992, 1 page.
- Nextstep, "Object-Oriented Programming And The Objective C Language," Apr. 1993, 257 pages, Addison-Wesley Publishing Company, Reading, MA.
- Niemeyer et al., "Learning Java," Third Edition, 2005, 978 pages, O'Reilly Media, Inc., Sebastopol, CA.
- Norman et al., "User Centered System Design, New Perspectives on Human-Computer Interaction," 1986, 532 pages, Lawrence Erlbaum Associates, Inc., Hillsdale, NJ.
- Ogawa et al., Preprocessing for Chinese Character Recognition and Global Classification of Handwritten Chinese Characters, Pattern Recognition, vol. 11, pp. 1-7, 1979, Pergamon Press Ltd., Great Britain.
- Oka et al., "Real-time Tracking of Multiple Fingertips and Gesture Recognition for Augmented Desk Interface Systems," 6 pages, Institute of Industrial Science, University of Tokyo, Tokyo, Japan [no date available].
- Olsen et al., "A Context for User Interface Management," IEEE Computer Graphics and Applications 4(12), 1984, 13 pages.
- Olsen, "Developing user Interfaces," 1998, 426 pages, Morgan Kaufmann Publishers, Inc., San Francisco, CA.
- Owen et al., "When It Gets More Difficult, Use Both Hands- Exploring Bimanual Curve Manipulation," 8 pages, Alias, Toronto, Ontario, Canada [no date available].
- Palm Inc., "iPhone's Multi-Touch Technology—Apple (Appl 949)," Jul. 5, 2009, 6 pages, Article One Partners—Research Reward Reform, Article One Partners Holdings, LLC.
- Pavet et al., "Use of Paper Strips by Tower Air Traffic Controllers and Promises Offered by New Design Techniques on User Interface," USA/Europe R&D Seminar ATM, 2001, 11 pages, Santa Fe, NM.
- Pavet et al., "Vigistrips: a highly interactive Human Machine Interface project for the benefit of major French airports," Dec. 2006, 14 pages, mhtml:file://S:\DFSR_DATA\data01\051900\Prior%20Art\915\00%20-%20Michael%20 . . .
- PenPoint API Reference, vols. 1-2, Addison-Wesley, 1992.
- Penpoint, "PenPoint API Reference," vol. 2, 1991, 605 pages, GO Corporation., Foster City, CA.
- Penpoint, "PenPoint Architectural Reference vol. 1," 1991, 655 pages, Addison-Wesley Publishing Company, Reading, MA.
- Perlin et al., "An Alternative Approach to the Computer Interface," Courant Institute of Mathematical Sciences, NYU, pp. 1-11, New York, NY [no date available].
- Perry et al., "An Investigation of Current Virtual Reality Interfaces," 17 pages, Crossroads, The ACM Student Magazine [no date available].
- Petzold, "Programming Windows," Fifth Edition, 1999, 1518 pages, Microsoft Press, Redmond, WA.
- Phan, "Focus+Context Sketching on a PDS," Dec. 2003, 65 pages, A paper submitted to the faculty of San Francisco State University, San Francisco, CA.
- Philipp, "Controls & Sensors: Tough Touch Screen," Feb. 1, 2006, 6 pages, http://www.appliancedesign.com/copyright/75872c1b0b819010VgnVCM100000f932a8c . . .
- Pickering, "Touch-sensitive screens: the technologies and their application," 1986, 21 pages, Academic Press Inc., London.
- Piquepaille, "Exclusive Interview with Jackito's Makers," Jul. 21, 2004, 3 pages, http://web.archive.org/web/20040806182136/http://radio.weblogs.com/0105910/2004/07/21.html.
- Piquepaille, "Forget the PDA, Here Comes the TDA," Jul. 21, 2004, 2 pages, http://web.archive.org/web/20040806134919/http://radio.weblogs.com/0105910/categories/sidebars/2004/07/12/html.
- Plasmaplugs, "PlasmaplugsScrollBar," Aug. 24, 2006, 1 page.
- PR Newswire, "FingerWorks Announces a Gesture Keyboard for Apple PowerBooks," 2011, 2 pages, http://www.prnewswire.com/news-releases/fingeworks-announces-a-gesture-keyboard-for-apple-powerbooks-59032847.html.
- PR Newswire, "FingerWorks Announces the ZeroForce iGesture Pad for Macs and PCs," 2011, 2 pages, http://www2.prnewswire.com/cgi-bin/stories.pl?ACCT=104&STORY=/www/story/02-18-2003/000893081&EDATE=.
- Prasad et al., "Exploring the Feasibility of Video Mail for Illiterate Users," Conference AVI '08, May 2008, 8 pgs., Napoli, Italy.
- Principles of Animation: "Slow In and Out", 1 page, 2010, http://www.siggraph.org/education/materials/HyperGraph/animation.
- ProQuest, "Adobe Rolls Out Flash Player 9", Wireless News, Jun. 28, 2006, 8 pages.
- Prosize, "Programming Microsoft.Net," 2002, 801 pages, Microsoft Press, Redmond, WA.
- Quantum Research Group Ltd., "Preliminary QProx QT60320 Product Information," 1999, 14 pgs., Quantum Research Group Ltd., Pittsburgh, PA.
- Quantum Research Group Ltd., "Preliminary QT60325, QT60485, QT60645 Product Information," 2001, 42 pgs., Quantum Research Group Ltd., Hamble, GB.
- Quantum Research Group Ltd., "QMatrix QT60040 Product Information," 2000, 10 pgs., Quantum Research Group Ltd., Pittsburgh, PA.
- Quantum Research Group, "Company and Technology Overview," 2006, 20 pages.
- Quantum Research Group, "Design Wins," May 2006, 25 pages.
- Quantum Research Group, "Qmatrix Panel Design Guidelines," Oct., 2002, 4 pages.
- Quantum Research Group, "Qmatrix Technology White Paper," 2006, 4 pages.
- Raab et al., "Pedagogical Power Tools for Teaching Java," ITiCSE, 2000, 4 pages, ACM, Helsinki, Finland.
- Railane et al., "Tackling the Problem of Flight Integration," 10 pages, Toulouse, France [no date available].
- Ramos et al., "Pointing Lenses: Facilitating Stylus Input Through Visual- and Motor-Space Magnification," CHI 2007 Proceedings: Mobile Interaction Techniques II, Apr. 28-May 3, 2007, pp. 757-766, ACM, San Jose, California.
- Ramos et al., "Pressure Marks," CHI 2007 Proceedings: Alternative Interaction, Apr. 28-May 3, 2007, pp. 1375-1384, ACM, San Jose, California.
- Ramos et al., "Pressure Widgets," CHI 2004, vol. 6, No. 1, Apr. 24-29, 2004, 8 pages, ACM, Vienna, Austria.
- Ramos et al., "Visual Features and Interference in Pressure Widget," Apr. 2004, 11 pages, University of Toronto.
- Ramos et al., "Zliding: Fluid Zooming and Sliding for High Precision Parameter Manipulation," UIST'05, Oct. 23-27, 2005, 10 pages, ACM, Seattle, WA.
- Ramos, et al., "Fluid Interaction Techniques for the Control and Annotation of Digital Video," 2003, pp. 105-114, ACM, Vancouver, BC, Canada.
- Ranjan et al., "An Exploratory Analysis of Partner Action and Camera Control in a Video-Mediated Collaborative Task," CSCW '06, Nov. 4-8, 2006, 10 pages, ACM, Banff, Alberta, Canada.
- Ranjan et al., "Dynamic Shared Visual Spaces: Experimenting with Automatic Camera Control in a Remote Repair Task," CHI 2007

(56)

References Cited

OTHER PUBLICATIONS

- Proceedings: People, Looking at People, Apr. 28-May 3, 2007, pp. 1177-1186, ACM, San Jose, California.
- Ranjan et al., "Improving Meeting Capture by Applying Television Production Principles with Audio and Motion Detection," CHI 2008 Proceedings: Improved Video Navigation and Capture, Apr. 5-10, 2008, pp. 227-236, ACM, Florence, Italy.
- Ranjan et al., "Searching in Audio: The Utility of Transcripts, Dichotic Presentation, and Time-Compression," CHI 2006 Proceedings: Search & Navigation: Mobiles & Audio, Apr. 22-27, 2006, pp. 721-730, ACM, Montreal, Quebec, Canada.
- Rasala et al., "Java Power Tools: Model Software for Teaching Object-Oriented Design," SIGCSE, 2001, 5 pages, ACM, Charlotte, NC.
- Raskar et al., "Intelligent Clusters and Collaborative Projector-based Displays," CVRV 2003, Oct. 2003, 6 pages, Mitsubishi Electric Research Laboratories, Inc., Cambridge, MA.
- Reetz et al., "Superflick: A Natural and Efficient Technique for Long-Distance Object Placement on Digital Tables," 8 pages, University of Saskatchewan, Saskatoon, Canada.
- Reexam Request for U.S. Patent No. 7469381, dated Apr. 28, 2010, 51 pages.
- Rekimoto et al., "Augmented Surfaces: A Spatially Continuous Work Space for Hybrid Computing Environments," year and publisher unknown, 8 pages.
- Rekimoto, "Pick-and-Drop: A Direct Manipulation Technique for Multiple Computer Environments," UIST 97, 1997, 9 pages, ACM, Banff, Alberta, Canada.
- Rekimoto, "SmartSkin: An Infrastructure for Freehand Manipulation on Interactive Surfaces," Paper: Two-Handed Interaction, Apr. 20-25, 2002, pp. 113-120, vol. 4, No. 1, CHI Letters, Minneapolis, MN USA.
- Rekimoto, "Tilting Operations for Small Screen Interfaces," 2 pages, Sony Computer Science Laboratory, Inc., Tokyo, Japan [no date available].
- Robertson et al., Data Mountain: Using Spatial Memory for Document Management, UIST '98, 1998, pp. 153-162, ACM, San Francisco, CA.
- Rosenberg et al., "Real-Time Stereo Vision using Semi-Global Matching on Preprogrammable Graphics Hardware," 1 page, New York University [no date available].
- Rosenthal et al., "The Detailed Semantics of Graphics Input Devices," Computer Graphics, vol. 16, No. 3, Jul. 1982, 6 pages, ACM.
- Ross, "Gazing into the Crystal Ball, But what shape should the cursor be?," Jan. 20, 2003, Toronto Star, 3 pages, <http://www.dpg.toronto.edu/~ravin/press/TorontoStar20030120.htm>.
- Rubine et al., "Programmable Finger-Tracking Instrument Controllers," Computer Music Journal, 1990, pp. 26-41, vol. 14, No. 1, Massachusetts Institute of Technology, Cambridge, MA.
- Rubine et al., "The VideoHarp," Proceedings of the 14th International Computer Music Conference, Sep. 20-25, 1988, 8 pages.
- Rubine, "Combining Gestures and Direct Manipulation," Proceedings of the CHI '92 Conference on Human Factors in Computing Systems, May 3-7, 1992, pp. 659-660, Association for Computing Machinery, New York.
- Rubine, "Integrating Gesture Recognition and Direct Manipulation," Proceedings of the Summer '91 USENIX Technical Conference, 1991, 19 pgs. [CMU-IT-91 100].
- Rubine, "Specifying Gestures by Example," Computer Graphics, Jul. 1991, pp. 329-337, vol. 25, No. 4, Association for Computing Machinery, New York.
- Rubine, "The Automatic Recognition of Gestures," Doctoral Thesis, Dec. 1991, 285 pgs., Carnegie Mellon University, Pittsburgh, PA [CMU-CS-91-202].
- Ryall et al., "Experiences with and Observations of Direct-Touch Tabletops," IEEE, Oct. 2005, 9 pages, Mitsubishi Electric Research Laboratories, Inc., Cambridge, MA.
- Ryall et al., "Exploring the Effects of Group Size and Table Size on Interactions with Tabletop Shared-Display Groupware," CSCW, Jan. 2004, 12 pages, Mitsubishi Electric Research Laboratories, Inc., Cambridge, MA.
- Ryall et al., "iDwidgets: Parameterizing Widgets by User Identity," Interact 2005, Jul. 2005, 5 pages, Mitsubishi Electric Research Laboratories, Inc., Cambridge, MA.
- Ryall et al., "Temporal Magic Lens: Combined Spatial and Temporal Query and Presentation," Interact 2005, Jul. 2005, 15 pages, Mitsubishi Electric Research Laboratories, Inc., Cambridge, MA.
- Safety and Regulatory Information, 15 pages [no date available].
- Salaun et al., "Innovative HMI for the busiest airport towers," 4 pages [no date available].
- Saponas et al., "Demonstrating the Feasibility of Using Forearm Electromyography for Muscle-Computer Interfaces," CHI 2008 Proceedings: Physiological Sensing for Input, Apr. 5-10, 2008, pp. 515-524, ACM, Florence, Italy.
- Saponas et al., "Enabling Always-Available Input with Muscle-Computer Interfaces," UIST '09, Oct. 4-7, 2009, pp. 167-176, ACM, Victoria, British Columbia, Canada.
- Sarma, "Liquid Crystal Displays," 2004, 21 pages, CRC Press LLC.
- Schmidt et al., "Sketching and Composing Widgets for 3D Manipulation," Eurographics 2008, vol. 27, No. 3, 10 pages.
- Schmidt et al., "There is more to Context than Location," 10 pages, University of Karlsruhe, Karlsruhe, Germany [no date available].
- Scott et al., "Investigating Tabletop Territoriality in Digital Tabletop Workspaces," Technical Report, 2006-836-29, 2006, pp. 1-10, Dept. of Computer Science, University of Calgary, Calgary, Alberta, Canada.
- Scott et al., "Storage Bins: Mobile Storage for Collaborative Tabletop Displays," Jul./Aug. 2005, 8 pages, IEEE Computer Society.
- Scott, "Territoriality in Collaborative Tabletop Workspaces," Mar. 2005, 307 pages, The University of Calgary, Alberta, Canada.
- Sears, "High Precision Touchscreens: Design Strategies and Comparisons With a Mouse," Int. J. Man—Machine Studies, 1991, pp. 593-613, vol. 34.
- Sellen et al., "The Prevention of Mode Errors Through Sensory Feedback," Human-Computer Interaction, 1992, pp. 141-164, J. of HCI [<http://www.billbuxton.com/ModeErrors.html>].
- Sellen et al., "The Role of Visual and Kinesthetic Feedback in the Prevention of Mode Errors," Human-Computer Interaction ? INTERACT '90, Aug. 27-31, 1990, pp. 667-673, Elsevier Science Publishers B.V., Amsterdam, Holland.
- Sellen et al., "Using Spatial Cues to Improve Videoconferencing," Proceedings of CHI '92, 1992, pp. 651-652 [<http://www.billbuxton.com/hydra.html>].
- Sensor Frame, "The Sensor Frame Graphic Manipulator NASA Phase II Final Report," 1990 [Not 1992 as handwritten on p. 2, see p. 4 onward], 28 pgs., Sensor Frame, Inc., Pittsburgh, PA.
- Shapetape, "9 Photographic Illustrations," year unknown.
- Shen et al., "CoR2Ds: Context-Rooted Rotatable Draggables for Tabletop Interaction," CHI 2005, Apr. 2005, 5 pages, Mitsubishi Electric Research Laboratories, Inc., Cambridge, MA.
- Shen et al., "DiamondSpin: An Extensible Toolkit for Around-the-Table Interaction," CHI 2004, Jan. 2004, 10 pages, Mitsubishi Electric Research Laboratories, Inc., Cambridge, MA.
- Shen et al., "Informing the Design of Direct-Touch Tabletops," Sep./Oct. 2006, pp. 56-66, IEEE Computer Society.
- Shen et al., "Personal Digital Historian: Story Sharing Around the Table," Feb. 2003, Mitsubishi Electric Research Laboratories, Inc., Cambridge, MA.
- Shen et al., "Three Modes of Multi-Surface Interaction and Visualization," CHI, Apr. 2006, 5 pages, Mitsubishi Electric Research Laboratories, Inc., Cambridge, MA.
- Shen, "Multi-User Interface and Interactions on Direct-Touch Horizontal Surfaces: Collaborative Tabletop Research at MERL, Tabletop, Jan. 2006, 3 pages, Mitsubishi Electric Research Laboratories, Inc., Cambridge, MA.
- Sheng et al., "An Interface for Virtual 3D Sculpting via Physical Proxy," Graphite 2006, Nov. 29, 2006, 8 pgs., ACM, Kuala Lumpur, Malaysia.
- Shneiderman et al., "Designing The User Interface, Fourth Edition," 2005, 667 pages, Pearson Addison Wesley, Boston, MA.

(56)

References Cited

OTHER PUBLICATIONS

- Shneiderman, "4.3 Touchscreens now offer compelling uses," *IEEE Software*, Mar. 1991, vol. 8, No. 2, 9 pages, Ablex Publishing, Norwood, NJ.
- Shneiderman, "Direct Manipulation: A Step Beyond Programming Languages," Aug. 1983, 13 pages.
- Shneiderman, "Future Directions for Human-Computer Interaction," 1990, 19 pages, Department of Computer Science, University of Maryland, College Park, MD.
- Sibert et al., "An Object-Oriented User Interface Management System," *SIGGRAPH '86*, vol. 20, No. 4, Aug. 18-22, 1986, 10 pages, Dallas, TX.
- Siegel et al., "Performance Analysis of a Tactile Sensor," 1987, 7 pages, IEEE.
- Silberschatz et al., "Operating System Concepts," Third Edition, 1990, 704 pages, Addison-Wesley Publishing Co., Reading, MA.
- Sin, "Editing Digital Video With a Flick of the Wrist," *The Varsity Online*, Dec. 3, 2002, 2 pgs., University of Toronto, <http://www.dgp.toronto.edu/~ravin/press/Varsity20021104.htm>[Sep. 14, 2011 12:50:10 PM].
- Singh et al., "Numeric Paper Forms for NGOs," pp. 1-11 [no date available].
- Singh et al., "Virtual Reality Software and Technology," *Proceedings of the VRST '94 Conference*, Aug. 23-26, 1994, 8 pages, World Scientific, Singapore.
- Singh et al., "Visualizing 3D Scenes using Non-Linear Projections and Data Mining of Previous Camera Movements," *Afrigraph '04*, Nov. 3-5, 2004, 8 pages, ACM, Cape Town, South Africa.
- Small et al., "Design of Spatially Aware Graspable Displays," *CHI 97*, Mar. 22-27, 1997, 2 pages, MIT Media Laboratory, Cambridge, MA.
- Smith et al., "Croquet: A Menagerie of New User Interfaces," 8 pages. [no date available].
- Smith et al., "Electric Field Sensing for Graphical Interfaces," to be published in *Special Issue on Input Devices, IEEE Computer Graphics and Applications*, May 1998, 17 pgs., IEEE.
- Smith et al., "The Radial Scroll Tool: Scrolling Support for Stylus- or Touch-Based Document Navigation," *UIST 2004*, Oct. 24-27, 2004, 4 pages, ACM, Santa Fe, NM.
- Smith, "Field Mice: Extracting Hand Geometry From Electric Field Measurements," *IBM Systems Journal*, 1996, pp. 587-608, vol. 35, Nos. 3 and 4.
- Smith, "ISO and ANSI Ergonomic Standards for Computer Products," 1996, 351 pages, Prentice Hall, Upper Saddle River, USA.
- Son et al., "Comparison of contact sensor localization abilities during manipulation," *Robotics and Autonomous Systems*, 1996, 17 pages, Elsevier Science B.V.
- Sony Electronics, Inc., "VGN-U750P Notebook Product Information," Sony Electronics, Inc., 2004, 1 pg.
- Sony, *VAIO Instruction Manual*, 2004, 142 pages.
- Sprint, "HTC Arrive," *Basics Guide*, 2011, 129 pages.
- Sprint, "HTC Arrive," *User Guide*, 2011, 160 pages.
- Sprint, "HTC EVO Design 4G," *User Guide*, 2011, 276 pages.
- Sprint, "HTC Touch Pro," *User Guide*, 2008, 217 pages.
- Sprint, "Sprint PCS Service Sprint Power Vision Smart Device Treo 700 by Palm," 2006, 432 pages, USA.
- Standfield, "Haptic perception with an articulated, sensate robot hand," *Robotica* 1992, vol. 10, Part 6, pp. 497-508, Sandia National Laboratories, Albuquerque, NM.
- Stauffer, "Progress in Tactile Sensor Development," *Robotics Today*, Jun. 1983, 6 pages, The Society of Manufacturing Engineers.
- Stein, "What We Swept Under the Rug: Radically Rethinking CS1," *Computer Science Education*, vol. 8, No. 2, 1998, 13 pages, Swets and Zeitlinger.
- Sugimoto et al., "HybridTouch: An Intuitive Manipulation Technique for PDAs Using Their Front and Rear Surfaces," *MobileHCI '06*, Sep. 12-15, 2006, pp. 137-140, ACM, Helsinki, Finland.
- Sugiyama et al., "Tactile Image Detection Using a 1k-element Silicon Pressure Sensor Array," *Sensors and Actuators, A21-A23*, 1990, 4 pages, Elsevier Sequoia, Netherlands.
- Sun et al., "Flipper: a New Method of Digital Document Navigation," *CHI 2005*, Apr. 2-7, 2005, 4 pages, ACM, Portland, OR.
- Sun Microsystems, "Mobile Information Device Profile for Java™ 2 Micro Edition, Version 2.0," 1999-2002, 566 pages.
- Sun Microsystems, "PersonalJava Application Environment," *Archive—Java Technology Products Download*, Apr. 26, 2008, 13 pgs., Sun Microsystems, http://java.sun.com/jsp_utils/PrintPage.jsp?url=http%3A%2F%2Fjava.sun.com%2Fproducts%2Fpersonaljava%2Ftouchable%2F.
- Sutherland, "A Head-Mounted Three Dimensional Display," 1968, 8 pages.
- Suzuki et al., "A 1024-Element High-Performance Silicon Tactile Imager," *IEEE Transactions on Electron Devices*, Aug. 1990, pp. 1852-1860, vol. 37, No. 8.
- Synaptics Technology, "Transparent Capacitive Position Sensing," *Way Back Machine website*, as of Jul. 20, 2011, 4 pages, <http://web.archive.org/web/20010417174413/http://www.synaptics.com/technology/tcps.cfm>.
- Synaptics TouchPad Interfacing Guide, Second Edition, 1998, 91 pages.
- Synaptics, "Synaptics Announces Major Design Win With Toshiba for Leading-Edge Notebook," Mar. 4, 2002, 1 page, San Jose, CA.
- Szalavari et al., "The Personal Interaction Panel—A Two-Handed Interface for Augmented Reality" [Abstract only], *Computer Graphics Forum*, Sep. 1997, vol. 16, No. 3, Blackwell Publishing [<http://www.ingentaconnect.com/content/bpl/cgf/1997/00000016/00000003/art00171>; May 10, 2010].
- Tang et al., "VideoDraw: A Video Interface for Collaborative Drawing," *CHI '90 Proceedings*, Apr. 1990, pp. 313-320, Systems Sciences Lab., Xerox/Palo Alto Research Center, Palo Alto, CA.
- Tang et al., "VisTACO: Visualizing Tabletop Collaboration," *ITS '10*, Nov. 7-10, 2010, 10 pages, ACM, Saarbrücken, Germany.
- The Bumps, "An Important BumpTop Announcement," Apr. 30, 2010, <http://bumpstop.com>, 1 page.
- Thomas et al., "Animating Direct Manipulation in Human Computer Interfaces," Aug. 1997, 224 pages, South Australia.
- Thomas et al., "Animating Direct Manipulation Interfaces," *UIST 95*, Nov. 14-17, 1995, 10 pages, ACM, Pittsburgh, PA.
- Thomas et al., "Applying Cartoon Animation Techniques to Graphical User Interfaces," *ACM Transactions on Computer-Human Interaction*, vol. 8, No. 3, 2001, 25 pages, ACM.
- Thomas et al., "Graphical Input Interaction Technique (GIIT)," Jun. 2-4, 1982, 26 pages, Workshop Summary, Battelle Seattle Conference Center.
- Tidwell, "Designing Interfaces," 2006, 354 pages, O'Reilly Media, Inc., Sebastopol, CA.
- TMobile, "Dash 3G," *User Manual*, 2009, 192 pages.
- TMobile, "HTC HD2," 2010, 31 pages.
- TMobile, "HTC Sensation 4G," *Start Guide*, 21 pages [no date available].
- Toccatà, "Demonstrating Interaction Techniques for an ATC Workstation," 1 page, CENA, Toulouse, France [no date available].
- Tognazzini, "The 'Starfire' Video Prototype Project: A Case History," 2011, 12 pages, <http://www.asktog.com/papers/videoPrototypePaper.html>.
- Tohidi et al., "Getting the Right Design and the Design Right: Testing Many is Better Than One," *CHI 2006 Proceedings: Usability Methods*, Apr. 22-27, 2006, pp. 1243-1252, ACM, Montreal, Quebec, Canada.
- Tohidi et al., "User Sketches: A Quick, Inexpensive, and Effective Way to Elicit More Reflective User Feedback," *NordiCHI 2006: Changing Roles*, Oct. 14-18, 2006, pp. 105-114, ACM, Oslo, Norway.
- Traynor, "Java Concise Reference Series, Swing and AWT," 2008, 799 pages, Newport House Books, LLC.
- Truitt, "Electronic Flight Data in Airport Traffic Control Towers: Literature Review," *Federal Aviation Administration Technical Report*, Feb. 2006, 31 pgs., <http://actlibrary.tc.faa.gov>.
- Truscelli, "Radius Full Page Pivot," *Prova*, Apr. 1992, 6 pages, Roma.
- Tsang et al., "A Suggestive Interface for Image Guided 3D Sketching," Apr. 24-29, 2004, pp. 591-598, vol. 6, No. 1, *Letters CHI*, Vienna, Austria.

(56)

References Cited

OTHER PUBLICATIONS

- Tsang et al., "Boom Chameleon: Simultaneous capture of 3D view-point, voice and gesture annotations on a spatially-aware display," 10 pages, Toronto, Canada [no date available].
- Tsang et al., "Temporal Thumbnails: Rapid Visualization of Time-Based Viewing Data," 8 pages, University of Toronto [no date available].
- Tse et al., "Enabling Interaction With Single User Applications Through Speech and Gestures on a Multi-User Tabletop," AVI '06, Proceedings of Advanced Visual Interfaces, May 23-26, 2006, 8 pgs., ACM, Venezia, Italy.
- Tse et al., "Freehand Touch Gestures," 2009, 2 pages, Mitsubishi Electric Research Laboratories, Cambridge, MA.
- Tse et al., "GSI Demo: Multiuser Gesture/Speech Interaction over Digital Tables by Wrapping Single User Applications," ICMI, Nov. 2006, 9 pages, Mitsubishi Electric Research Laboratories, Inc., Cambridge, MA.
- Tse et al., "Multimodal Multiplayer Tabletop Gaming," PerGames, May 2006, 11 pages, Mitsubishi Electric Research Laboratories, Inc., Cambridge, MA.
- Tucker et al., "Programming Languages Principles and Paradigms," 2002, 423 pages, The McGraw-Hill Companies, Inc., New York, NY.
- VAIO, "Using your VAIO computer," User Manual, 2004, 142 pages, Sony Corporation.
- Verizon, "Droid Eris by HTC," User Guide, 2010, 260 pages.
- Verizon, "HTC Rezound," Master Your Device, 2011, 41 pages.
- Verizon, "HTC Rezound," User Guide, 2011, 348 pages.
- Verizon, "HTC Rhyme," Getting Started Guide, 66 pages [no date available].
- Verplaetse, "Inertial Proprioceptive Devices: Self-Motion-Sensing Toys and Tools," IBM Systems Journal, 1996, pp. 639-650, vol. 35, Nos. 3 and 4.
- Verplaetse, "Inertial-Optical Motion-Estimating Camera for Electronic Cinematography," 1997, 109 pages, Massachusetts Institute of Technology, MA.
- Viredaz, "The Itsy Pocket Computer Verison 1.5 User's Manual," Jul. 1998, 42 pages, Western Research Laboratory, Palo Alto, CA.
- Viredaz, "The Memory Daughter-Card Version 1.5 User's Manual," Jul. 1998, 17 pages, Western Research Laboratory, Palo Alto, CA.
- Virgin Mobile, "HTC Wildfire S," User Manual, 172 pages [no date available].
- Vogel et al., "Distant Freehand and Pointing and Clicking on Very Large High Resolution Displays," UIST'05, Oct. 23-27, 2005, 10 pages, ACM, Seattle, WA, USA.
- Vogel et al., "Hand Occlusion With Tablet -Sized Direct Pen Input," CHI 2009 Proceedings: Non-Traditional Interaction Techniques, Apr. 7, 2009, pp. 557-566, ACM, Boston, Massachusetts.
- Vogel et al., "Interactive Public Ambient Displays: Transitioning from Implicit to Explicit, Public to Personal, Interaction with Multiple Users," UIST '04, Oct. 24-27, 2004, 10 pages, ACM.
- Vogel et al., "Occlusion-Aware Interfaces," CHI 2010, Apr. 10-15, 2010, 10 pages, ACM, Atlanta, GA.
- Wahl, "Team Designs Twist on Software, Virtual shapes created on a computer screen by manipulating *ShapeTape*, a flexible tape-like tool," Apr. 15, 2003, 2 pages, University of Toronto, News@UofT, Toronto, CA.
- Wahlster, "An Intelligent Multimodal Interface," Methodologies for Intelligent Systems, 1988, pp. 101-111, vol. 3, Elsevier Science Publishing Co., Inc., Amsterdam, Holland.
- Walker, "A Cornucopia of Touch Technology," Information Display, 2006, 7 pages, SID.
- Walker, "Touch screen highlights from the SID 2006 show floor," Jun. 2006, 8 pages, Veritas et Visus, Touch Panel.
- Wallace, "The Semantics of Graphic Input Devices," 5 pages, University of North Carolina, Chapel Hill, NC [no date available].
- Want et al., "An Overview of the PARCTAB Ubiquitous Computing Experiment," Dec. 1995, 16 pages, IEEE.
- Ware et al., "Reaching for Objects in VR Displays: Lag and Frame Rate," ACM Transactions on Computer-Human Interaction, Dec. 1994, vol. 1, No. 4, 26 pages.
- Welch, "Hybrid Self-Tracker: An Inertial/Optical Hybrid Three-Dimensional Tracking System," 21 pages, University of North Carolina Chapel Hill, Chapel Hill, NC [no date available].
- Wellner, "Adaptive Thresholding for the DigitalDesk," Jul. 1993, 18 pages, EuroPARC Technical Report.
- Wellner, "Interacting With Paper on the DigitalDesk," Communications of the ACM, Jul. 1993, pp. 87-96, Association for Computing Machinery, New York.
- Wellner, "Self Calibration for the DigitalDesk," Jul. 1993, 16 pages, EuroPARC Technical Report.
- Wellner, "The DigitalDesk Calculator: Tactile Manipulation on a Desk Top Display," Proceedings of ACM Symposium on User Interface Software and Technology (UIST '91), Nov. 11-13, 1991, pp. 27-33.
- Westerman et al., "Multi-Touch: A New Tactile 2-D Gesture Interface for Human-Computer Interaction," Proceedings of the Human Factors and Ergonomics Society 45th Annual Meeting, 2001, 5 pages, University of Delaware.
- Westerman, "Hand Tracking, Finger Identification, and Chordic Manipulation on a Multi-Touch Surface," Doctoral Dissertation, University of Delaware, 1999, 363 pgs.
- Wigdor et al., "A Comparison of Consecutive and Concurrent Input Text Entry Techniques for Mobile Phones," Apr. 24-29, 2004, pp. 81-88, Letters CHI, vol. 6, No. 1.
- Wigdor et al., "Effects of Display Position and Control Space Orientation on User Preference and Performance," CHI 2006 Proceedings: Multidisplay Environments, Apr. 22-27, 2006, pp. 309-318, ACM, Montreal, Quebec, Canada.
- Wigdor et al., "Empirical Investigation into the Effect of Orientation on Text Readability in Tabletop Displays," 21 pages, University of Toronto [no date available].
- Wigdor et al., "Living with a Tabletop: Analysis and Observations of Long Term Office Use of a Multi-Touch Table," Tabletop 2007, Dec. 2007, 9 pages, Mitsubishi Electric Research Laboratories, Inc., Cambridge, MA.
- Wigdor et al., "Table-Centric Interactive Spaces for Real-Time Collaboration," AVI '06, 2006, 5 pgs., Association for Computing Machinery, Venezia, Italy.
- Wigdor et al., "Table-Centric Interactive Spaces for Real-Time Collaboration," images, date unknown, 1 pg., Mitsubishi Electric Research Laboratories.
- Wigdor et al., "Table-Centric Interactive Spaces for Real-Time Collaboration: Solutions, Evaluation, and Application Scenarios," journal, date, and publication information unknown, 6 pgs.
- Wigdor et al., "TiltText: Using Tilt for Text Input to Mobile Phone," 2003, ACM, pp. 81-90, UIST, Vancouver, BC, Canada.
- Wigdor et al., "Under the Table Interaction," UIST '06, Oct. 15-18, 2006, pp. 259-268, ACM, Montreux, Switzerland.
- Wigdor, "Perception of Elementary Graphical Elements in Tabletop and Multi-Surface Environments," CHI 2007 Proceedings: Innovative Interactions, Apr. 28-May 3, 2007, pp. 473-482, ACM, San Jose, California.
- Wikipedia, "Xgl," From Wikipedia, the free encyclopedia, 1 page, [no date available].
- Wilson et al., "FlowMouse: A Computer Vision-Based Pointing and Gesture Input Device," 14 pages, Microsoft Research, Redmond, WA [no date available].
- Wilson, "Robust Computer Vision-Based Detection of Pinching for One and Two-Handed Gesture Input," UIST '06, Oct. 15-18, 2006, 4 pgs., ACM, Montreux, Switzerland.
- Wilson, "TouchLight: An Imaging Touch Screen and Display for Gesture-Based Interaction," ICMI '04, Oct. 13-15, 2004, 8 pages, ACM, Pennsylvania, USA.
- Wilson., "Play Anywhere: A Compact Interactive Tabletop Projection-Vision System," UIST'05, Oct. 23-27, 2005, 10 pages, ACM, Seattle, WA.
- Wittenburg, Research On Public, Community, and Situated Displays at MERL Cambridge, Nov. 2002, 6 pages, Mitsubishi Electric Research Laboratories, Inc., Cambridge, MA.
- Wolfeld, "Real Time Control of a Robot Tactile Sensor," 1981, 68 pages, University of Pennsylvania.

(56)

References Cited

OTHER PUBLICATIONS

Woodfill et al., "Real-Time Stereo Vision on the Parts Reconfigurable Computer," IEEE Symposium on FPGAs for Custom Computing Machines, Apr. 1997, 10 pages.

Wu et al., "Gesture Registration, Relaxation, and Reuse for Multi-Point Direct-Touch Surfaces," Tabletop '06, Proceedings of the First IEEE International Workshop on Horizontal Interactive Human-Computer Systems, 2006, 8 pgs., IEEE.

Wu et al., "Multi-Finger and Whole Hand Gestural Interaction Techniques for Multi-User Tabletop Displays," 10 pages, to appear in ACM UIST 2003, Department of Computer Science, University of Toronto, CA.

Yamaashi et al., "Beating the Limitations of Camera-Monitor Mediated Telepresence with Extra Eyes," Proceedings of CHI '96, ACM Conference on Human Factors in Computing Systems, 1996, pp. 50-57, ACM, New York [<http://www.billbuxton.com/ExtraEyes.html>].

Yeh et al., "Optics of Liquid Crystal Displays," 1999, 10 pages, John Wiley & Sons, Inc., New York.

Zhai et al., "The "Silk Cursor": Investigating Transparency for 3D Target Acquisition," Human Factors in Computing Systems, Apr. 24-28, 1994, 7 pages, ACM, Boston, MA.

Zhai et al., "The Influence of Muscle Groups on Performance of Multiple Degree-Of-Freedom Input," Proceedings of CHI '96, Apr. 13-18, 1996, pp. 308-315, ACM, Inc., Vancouver, B.C., Canada.

Zhai et al., "The Partial Occlusion Effect: Utilizing Semi-Transparency in 3D Human Computer Interaction," ACM Transactions on Computer-Human Interaction, 1996, pp. 254-284, ACM, vol. 3, No. 3 [<http://www.billbuxton.com/silk.html>].

Zhao et al., "earPod: Eyes-Free Menu Selection Using Touch Input and Reactive Audio Feedback," CHI 2007 Proceedings: Alternative Interaction, Apr. 28-May 3, 2007, pp. 1395-1404, ACM, San Jose, California.

Zhao et al., "Simple vs Compound Mark Hierarchical Marking Menus," UIST '04, Oct. 24-27, 2004, 10 pages, ACM.

Zimmerman et al., "Applying Electric Field Sensing to Human-Computer Interfaces," [was to be published in] IEEE SIG CHI, 1995, 8 pgs.

Zukowski, "Java 1.1, JAVA AWT Reference," 1997, 1080 pages, O'Reilly & Associates, Inc., Sebastopol, CA.

Zukowski, "Java AWT Reference," 1997, 1085 pages, O'Reilly, Sebastopol, CA.

* cited by examiner

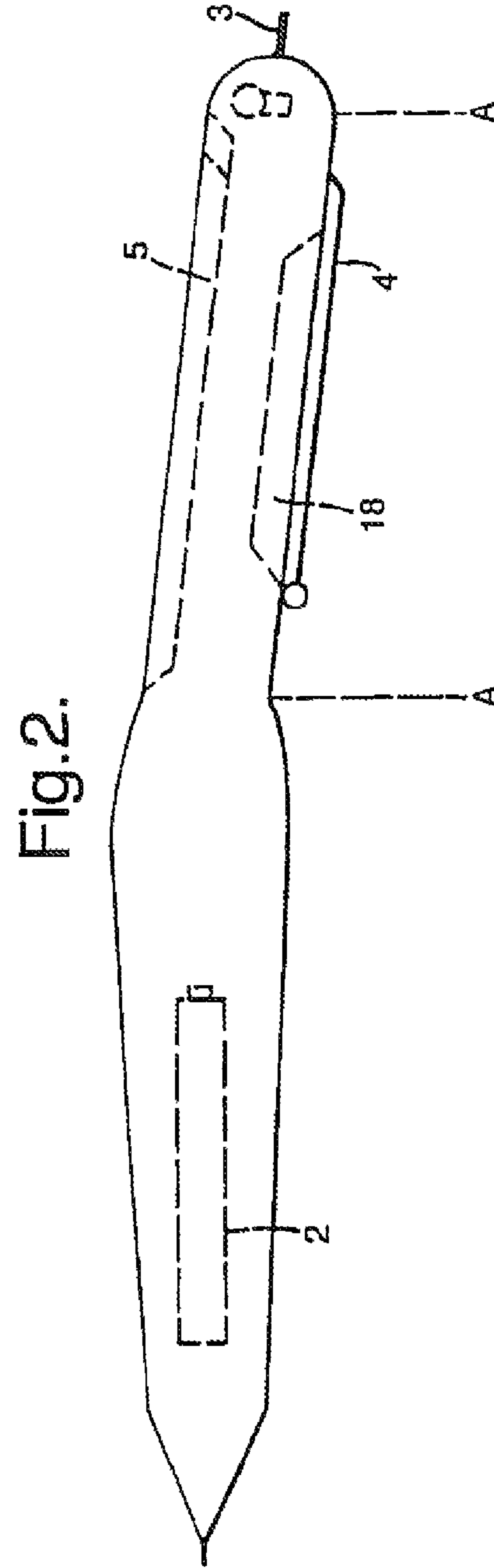
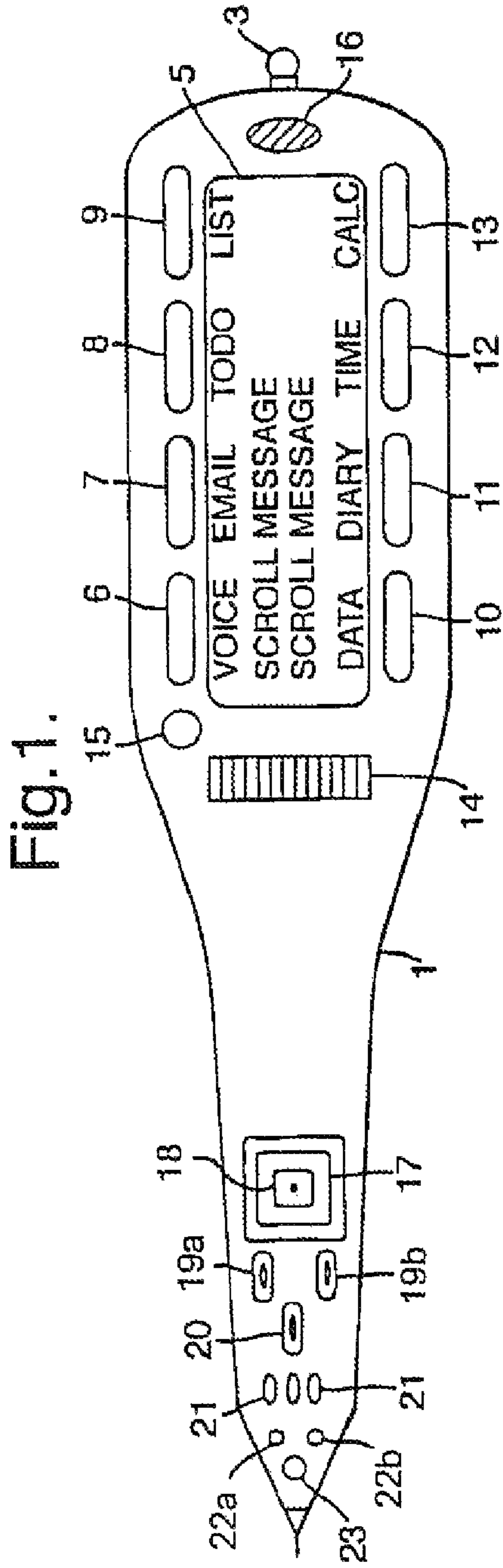
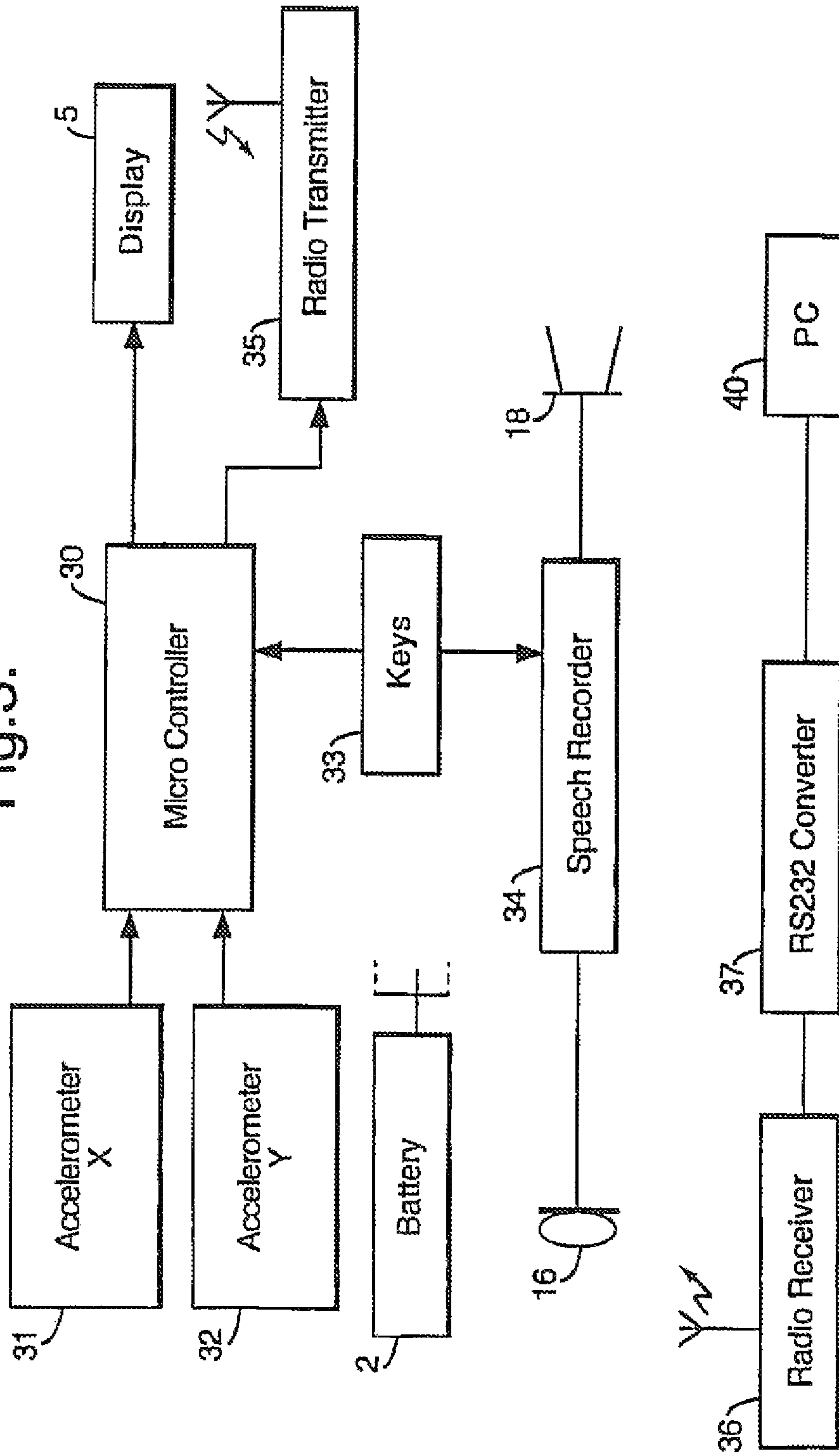

Fig. 3.



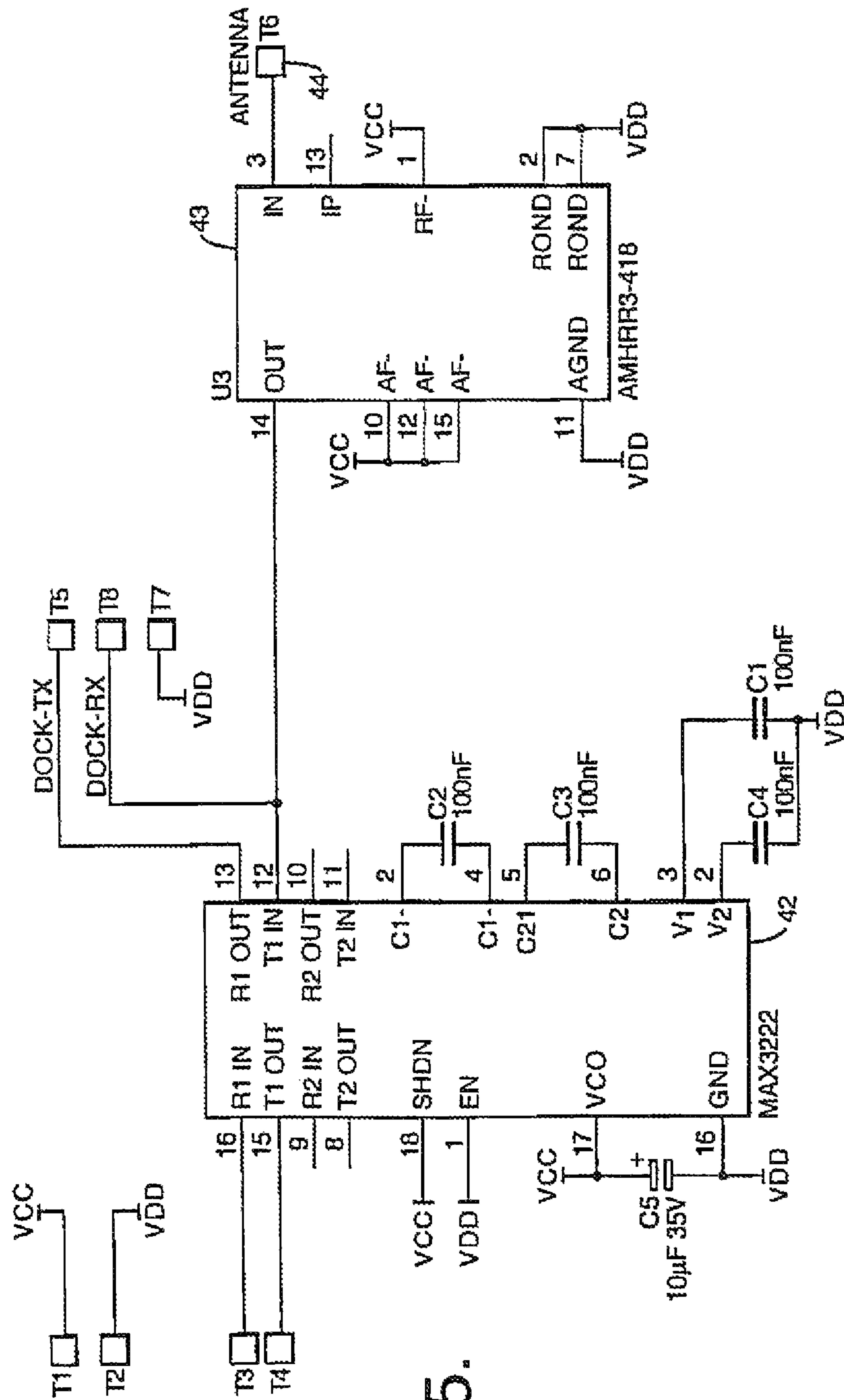

Fig.5.

Fig.6.

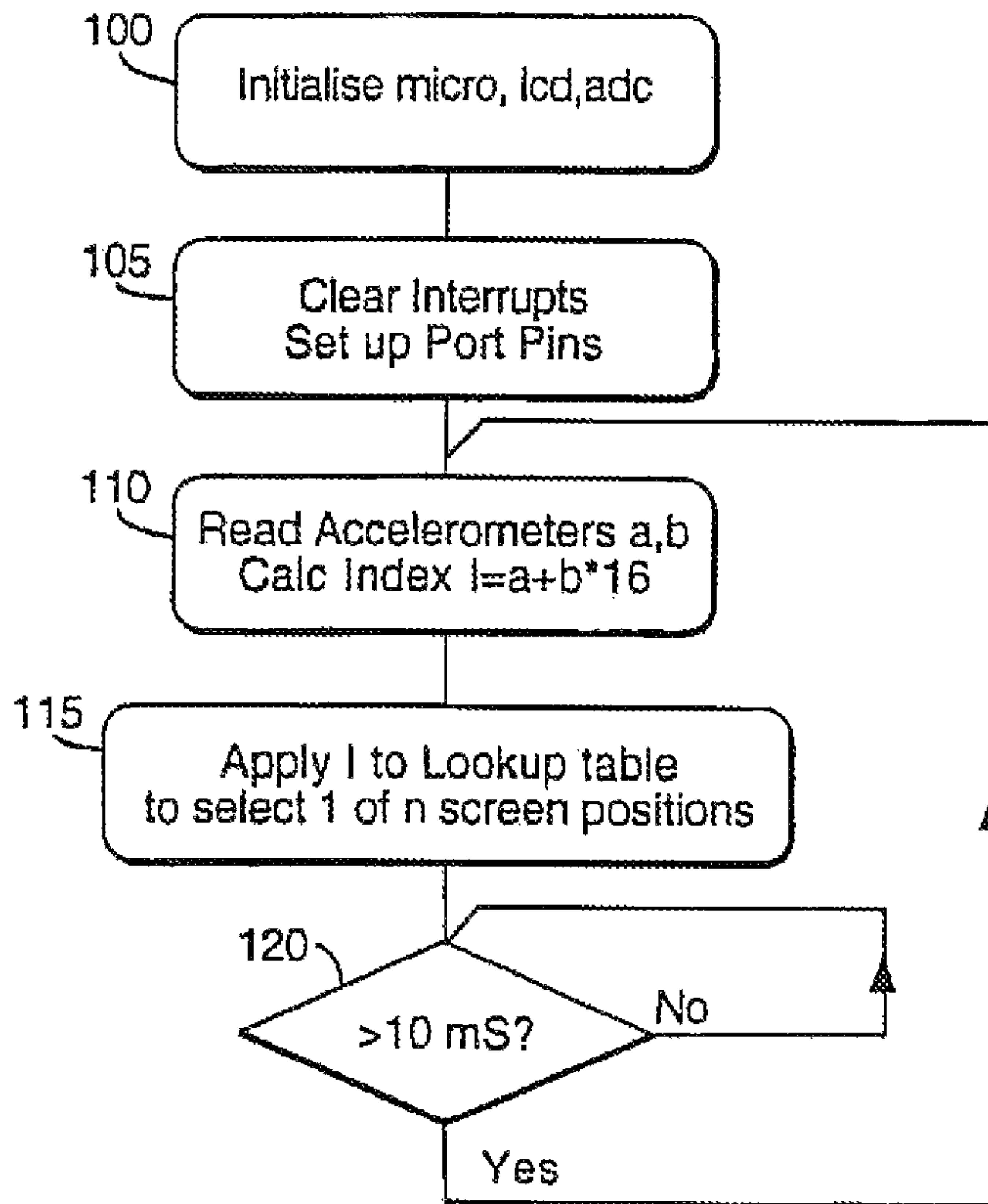

Fig.7a.

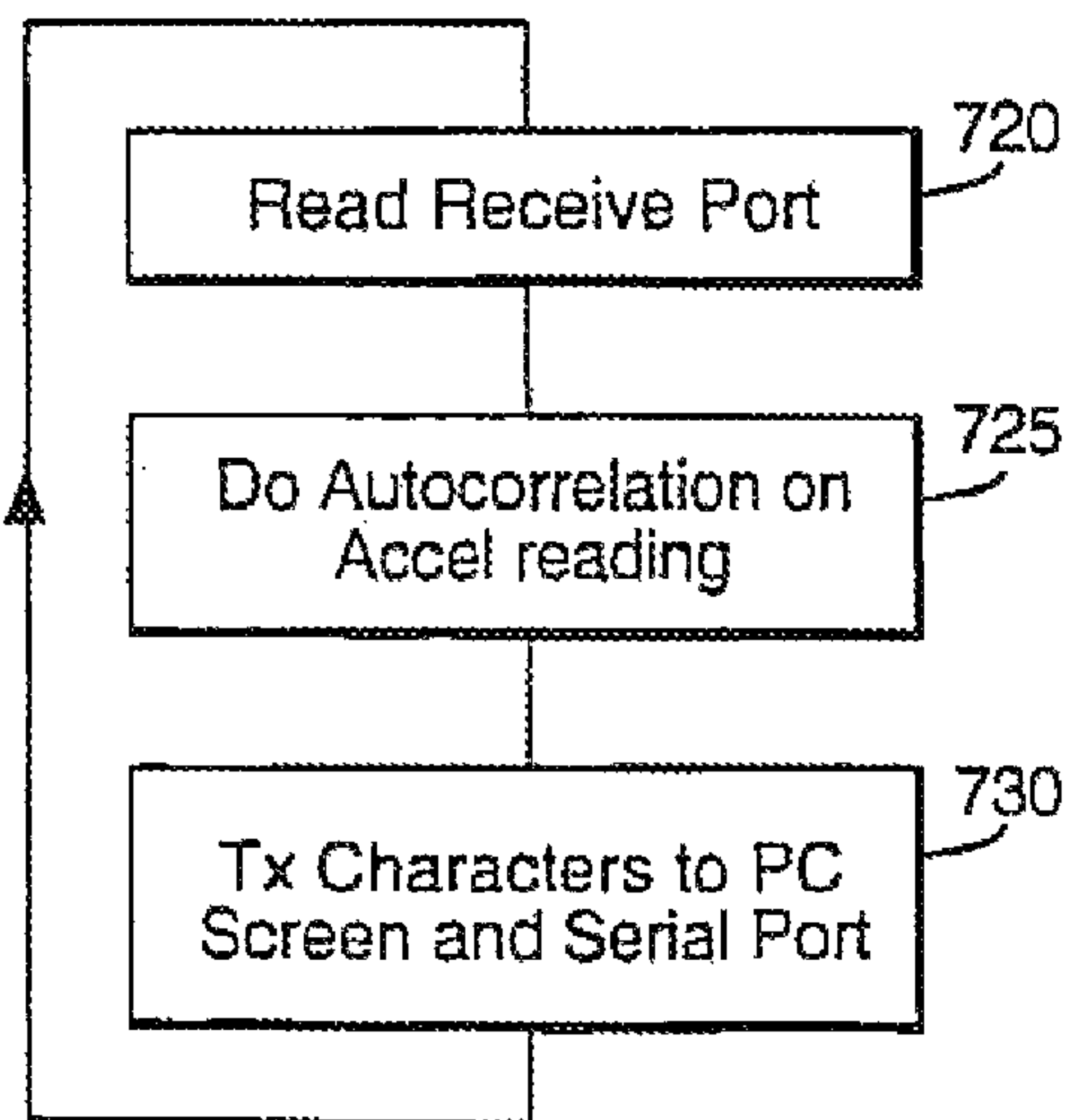

Fig.7b.

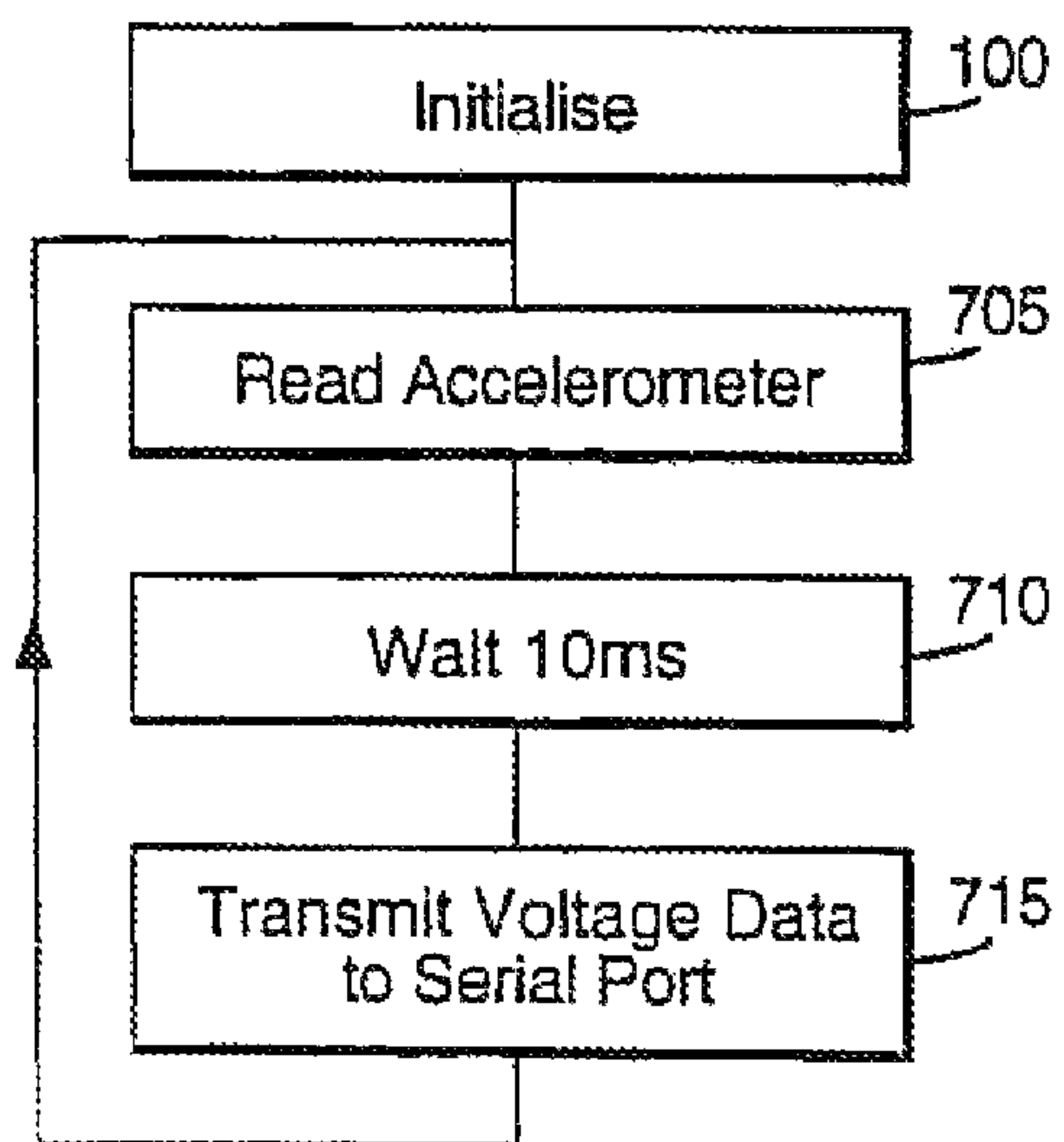

Fig.8.

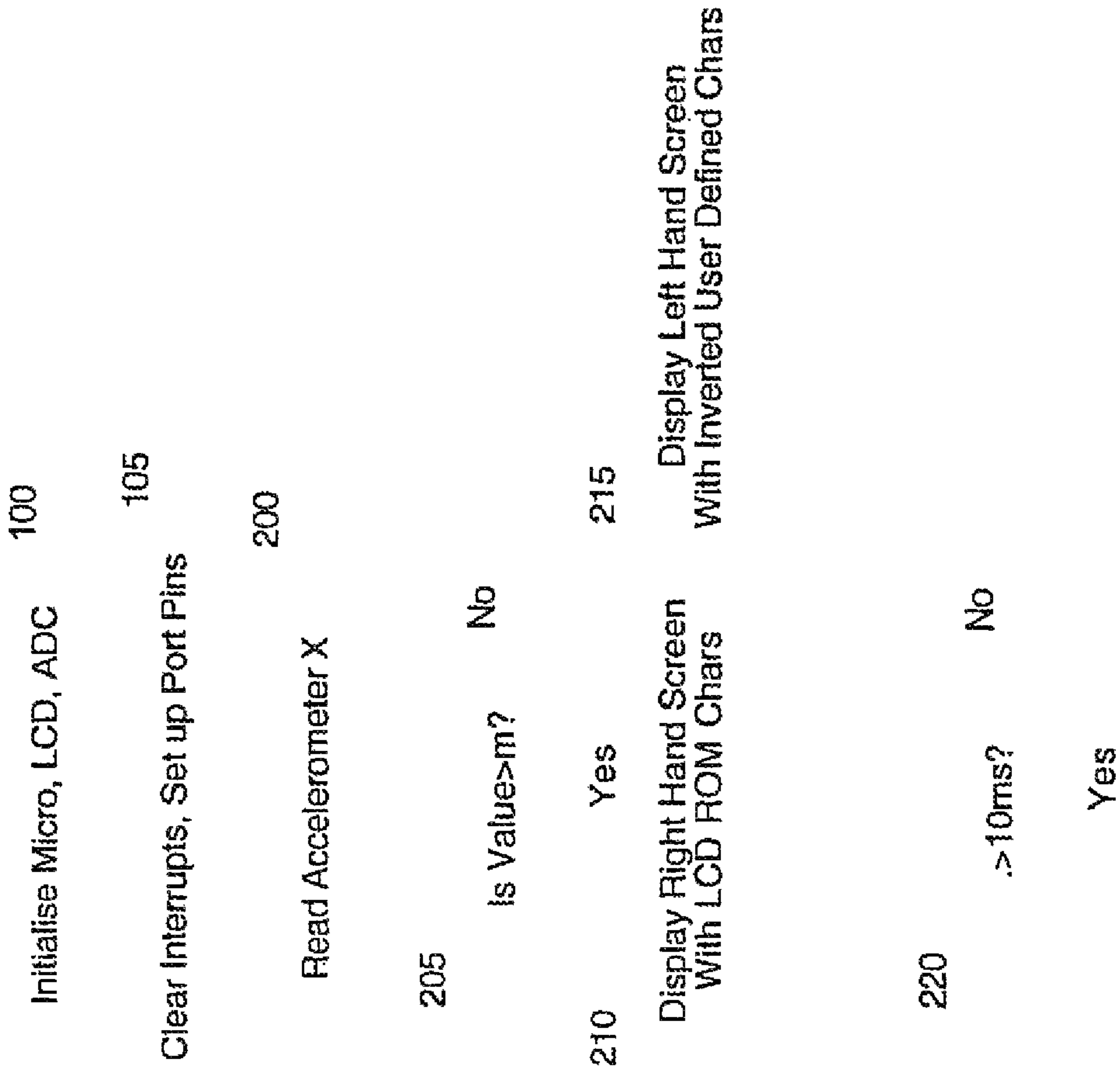
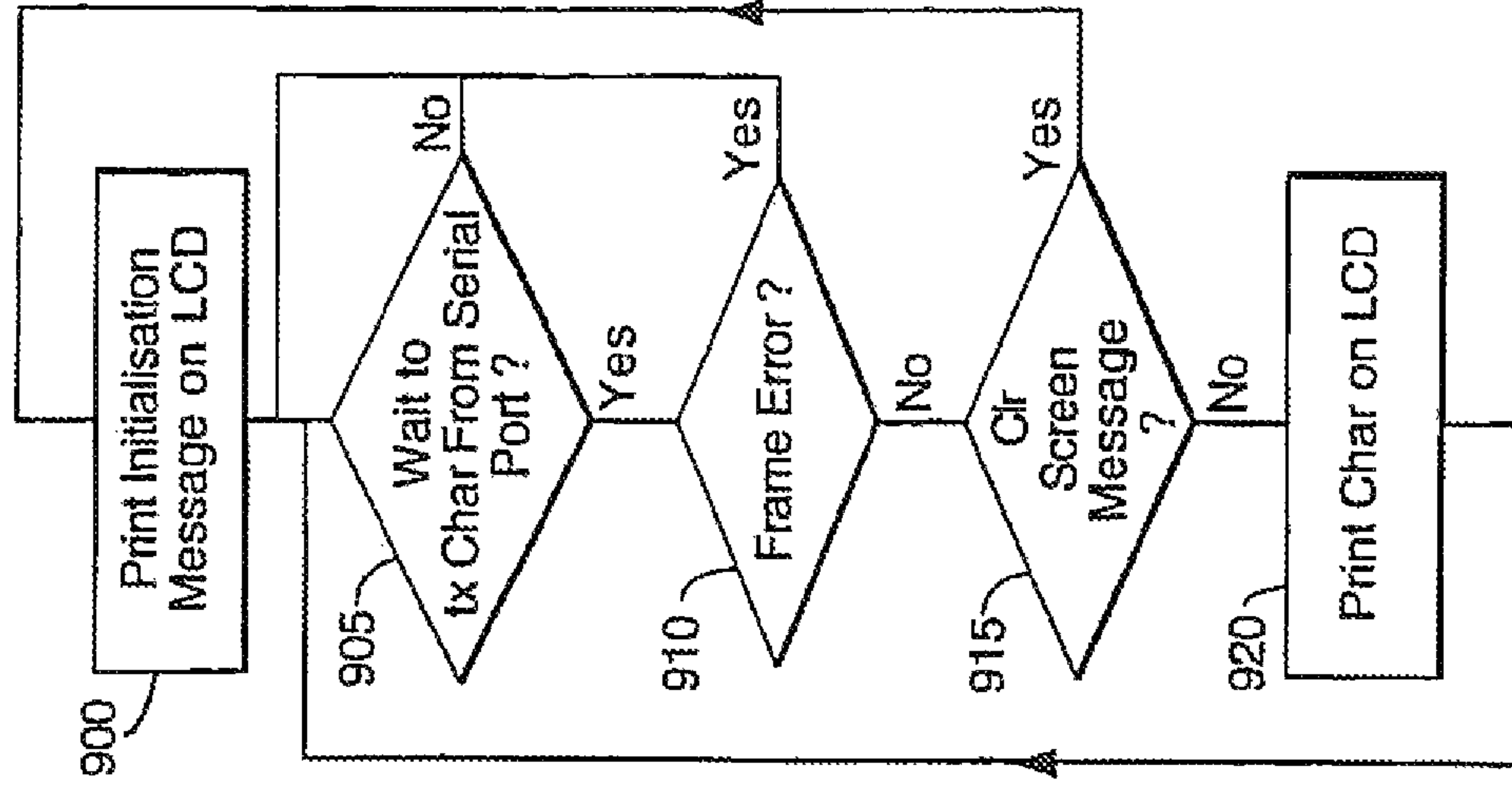

Fig.9.



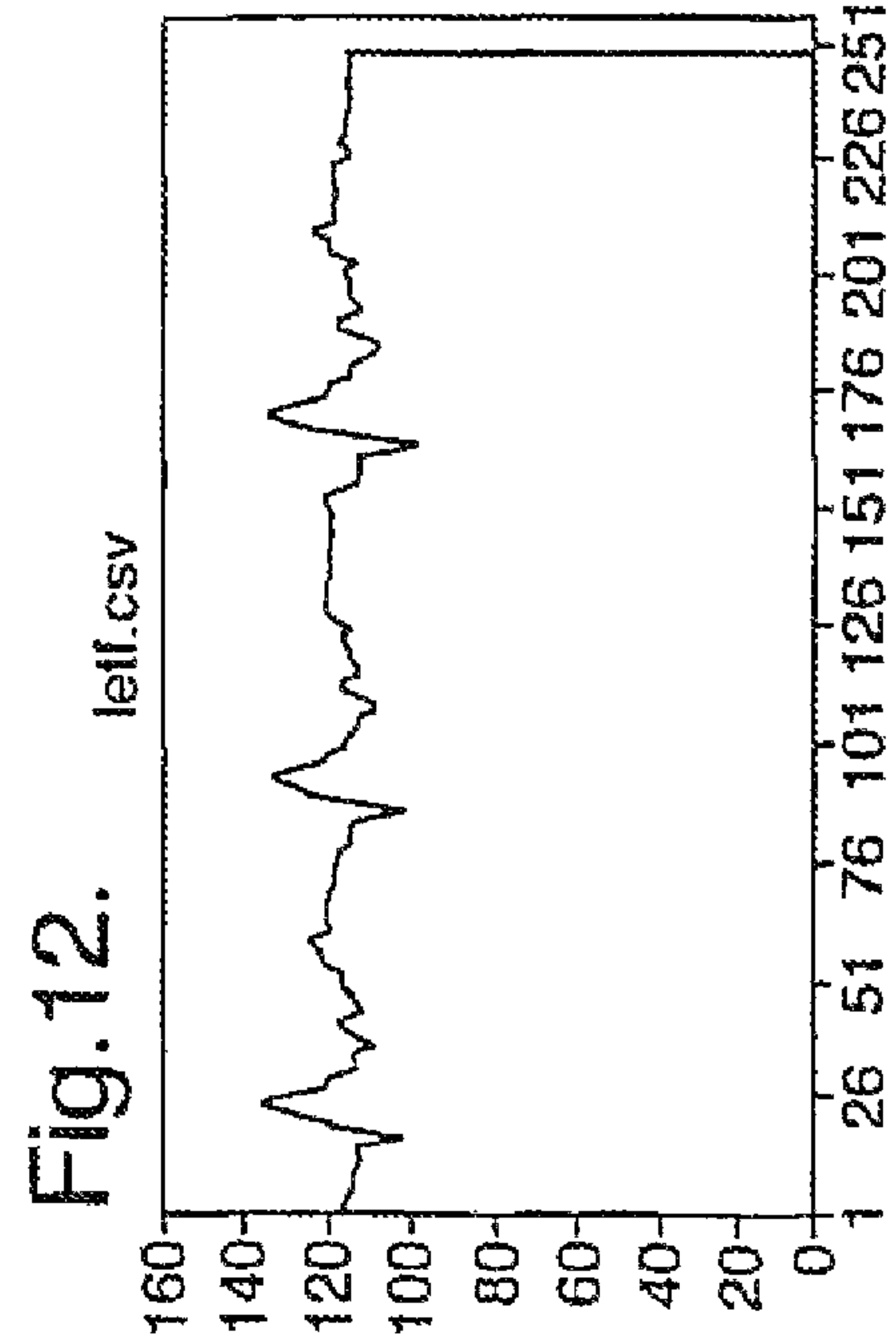
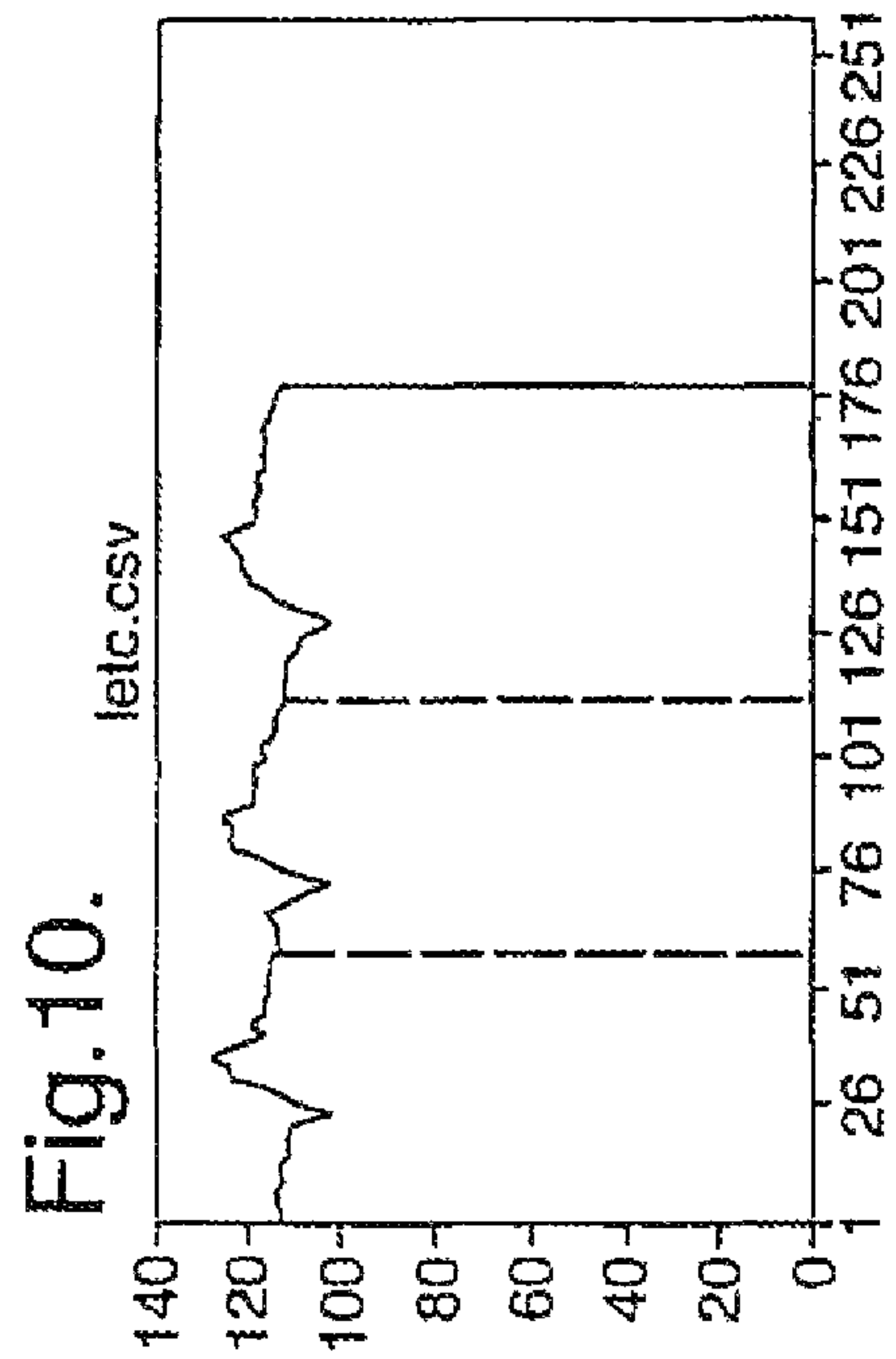
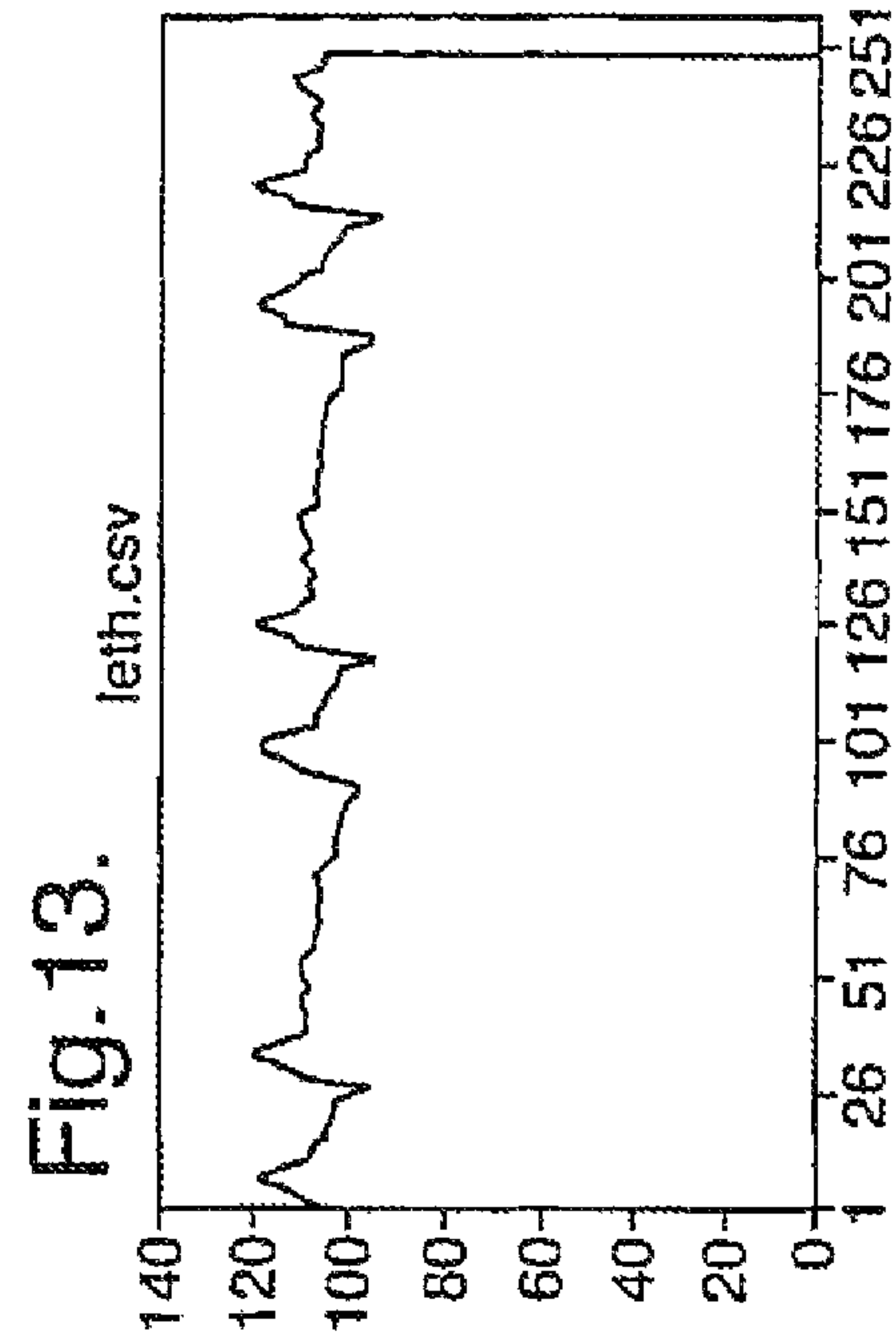
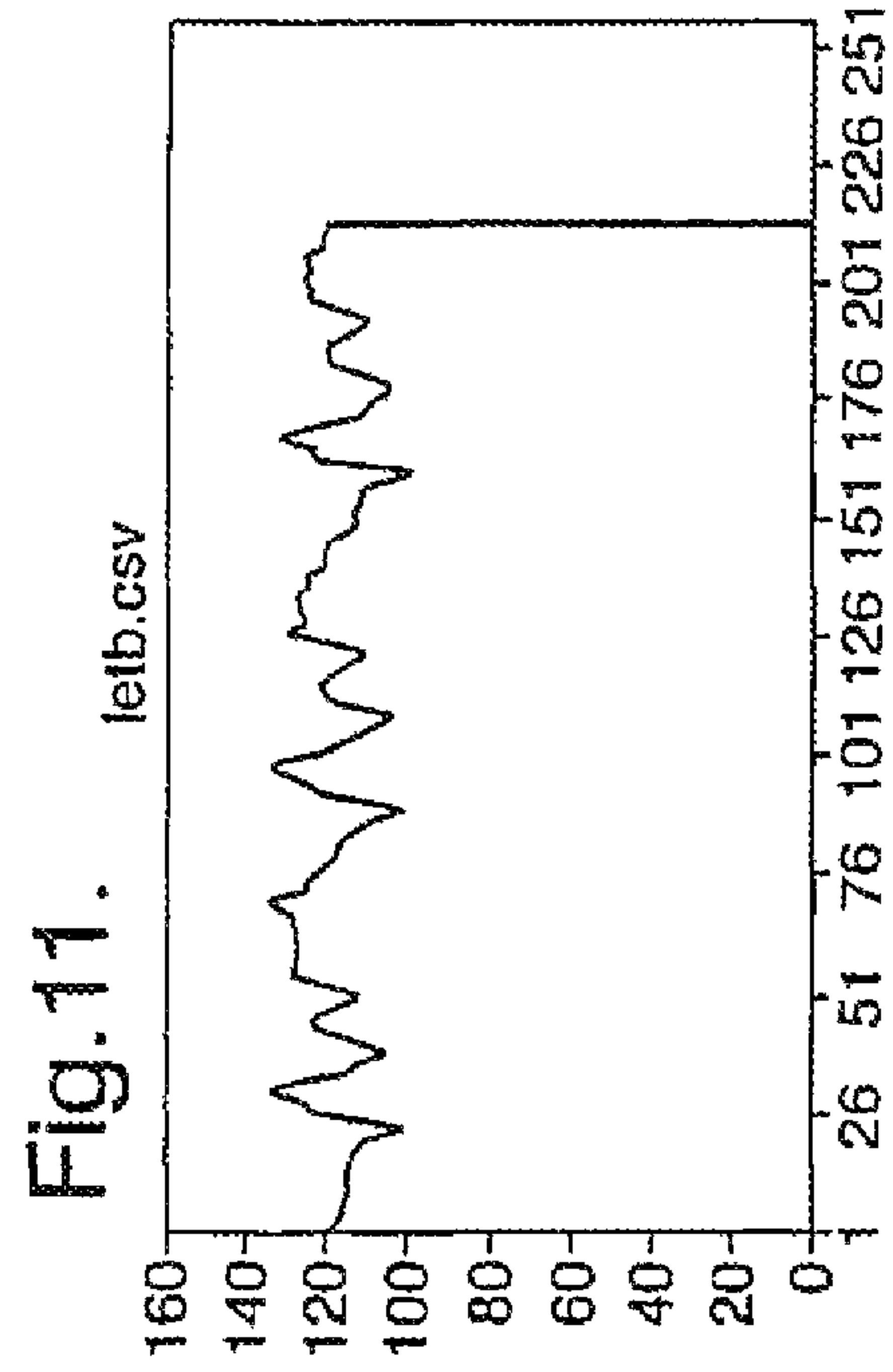

Fig. 14.

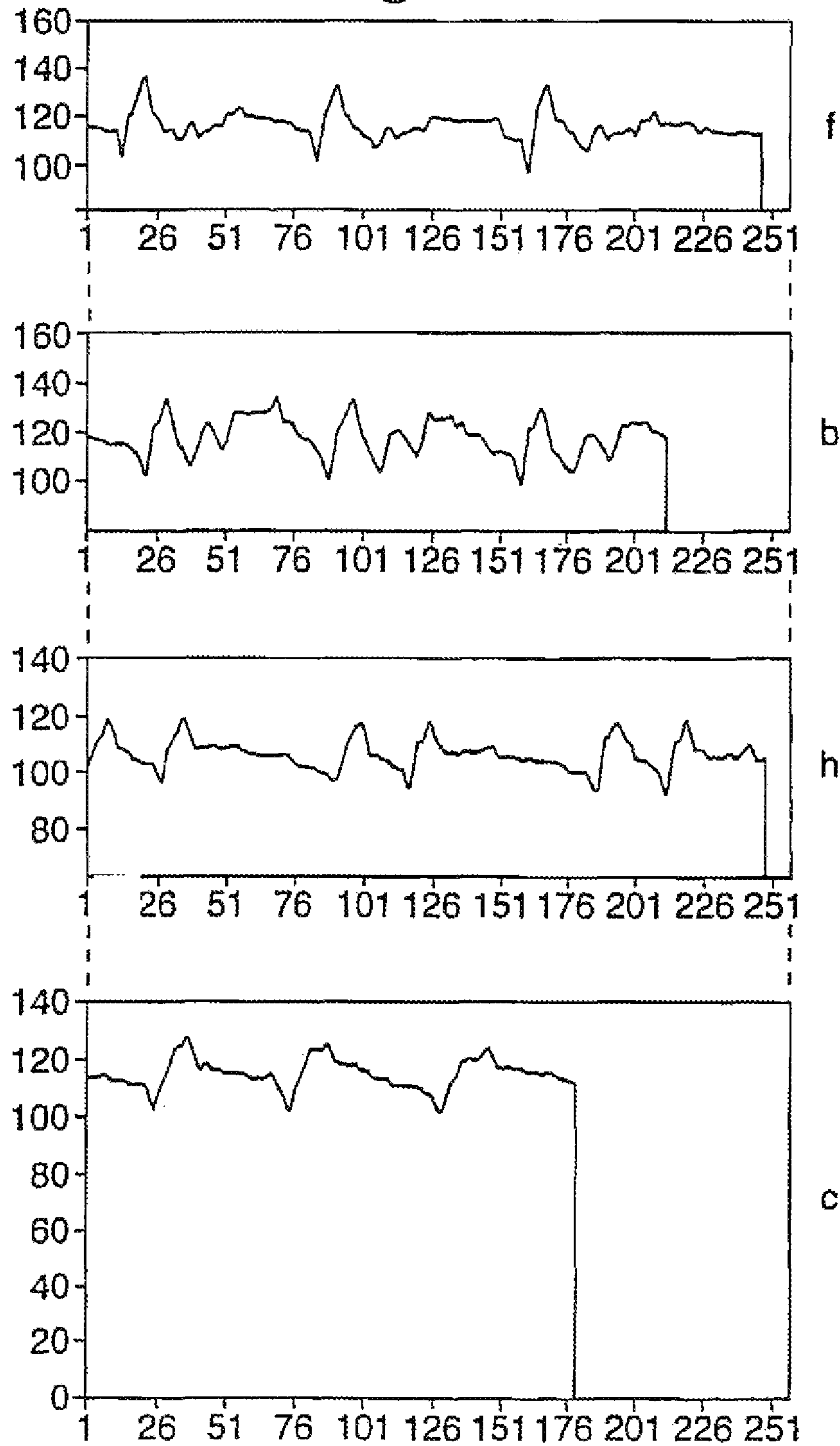

Fig.15.

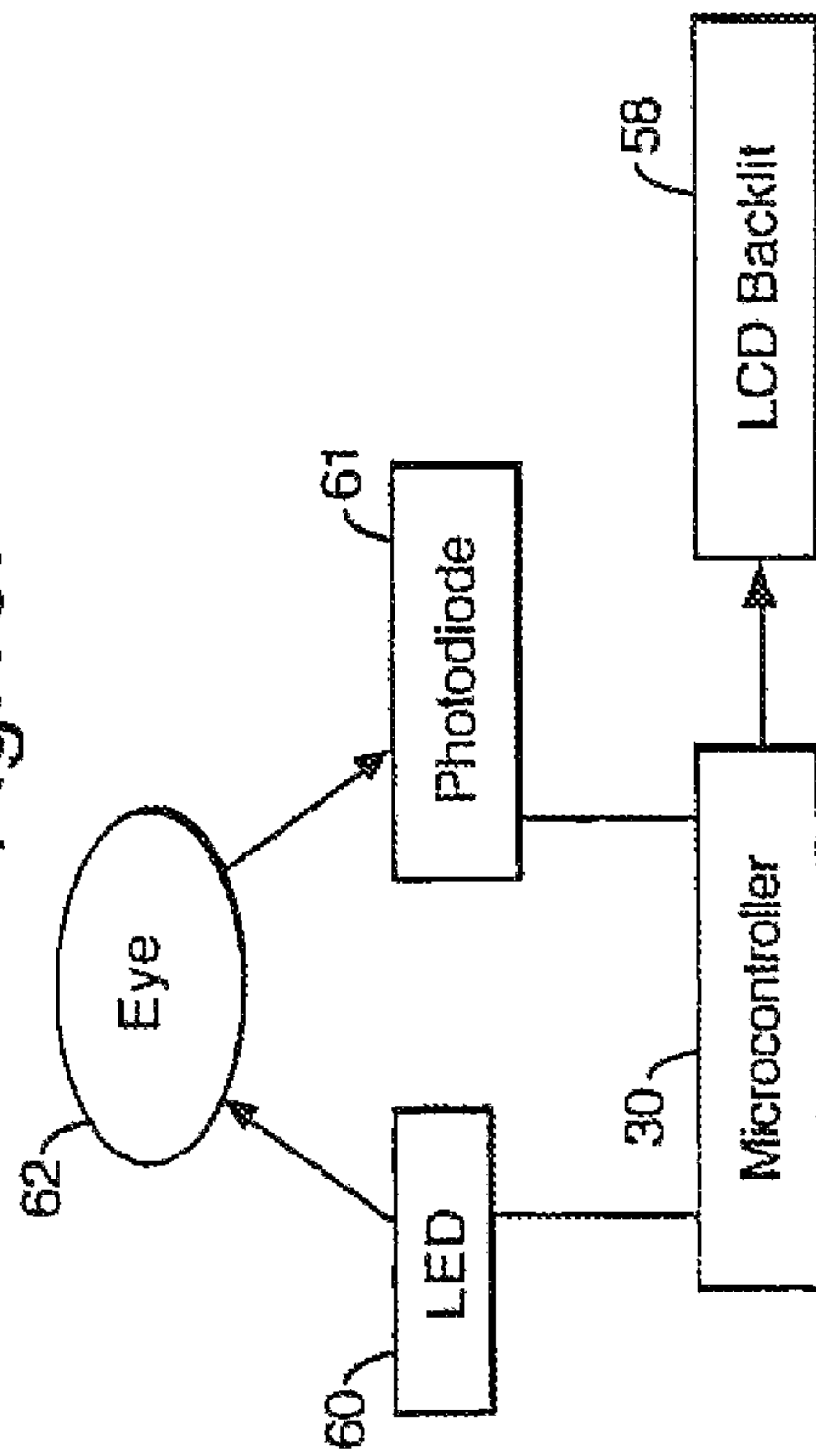

Fig.16.

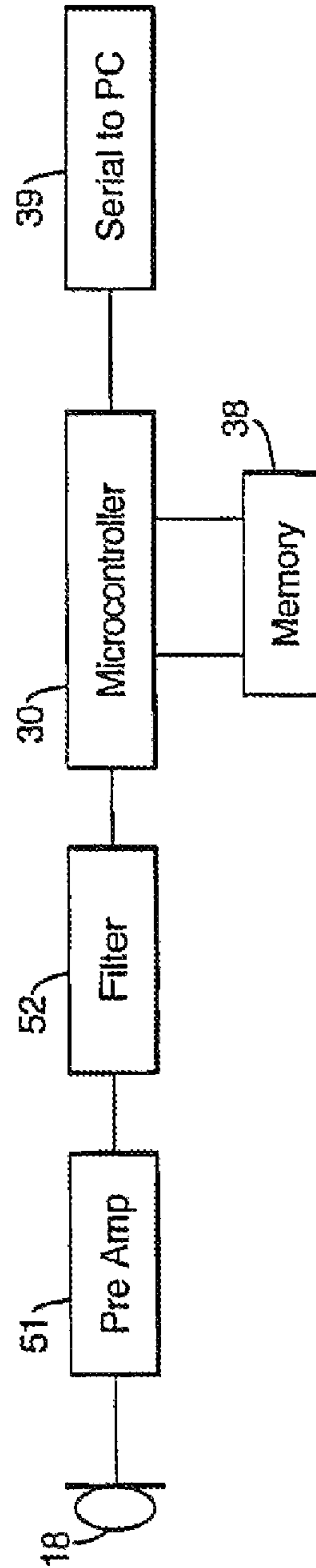

Fig. 17.

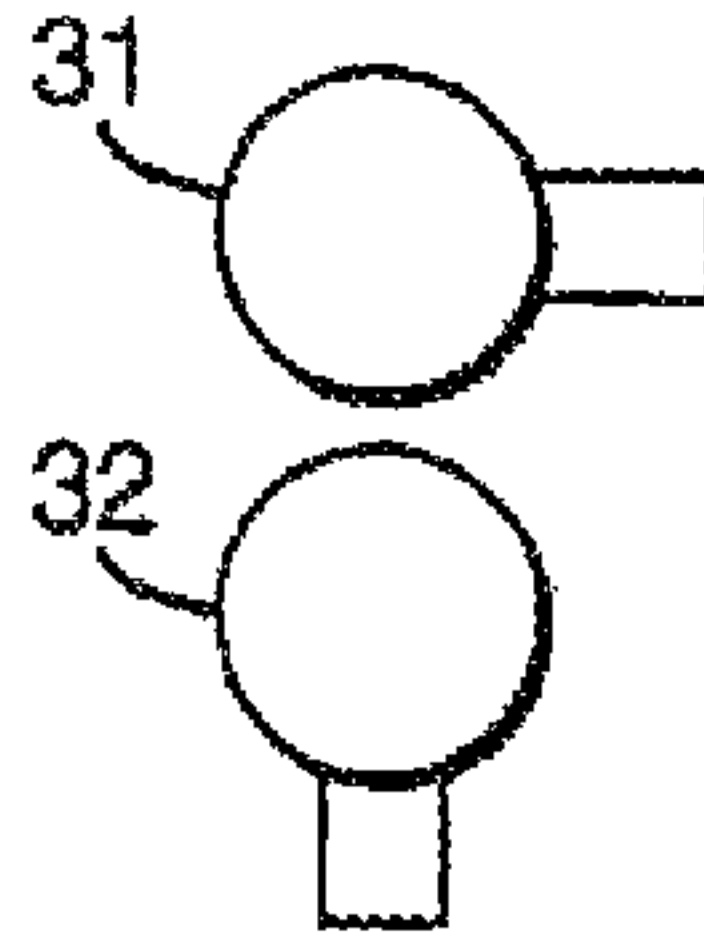

Fig. 18.

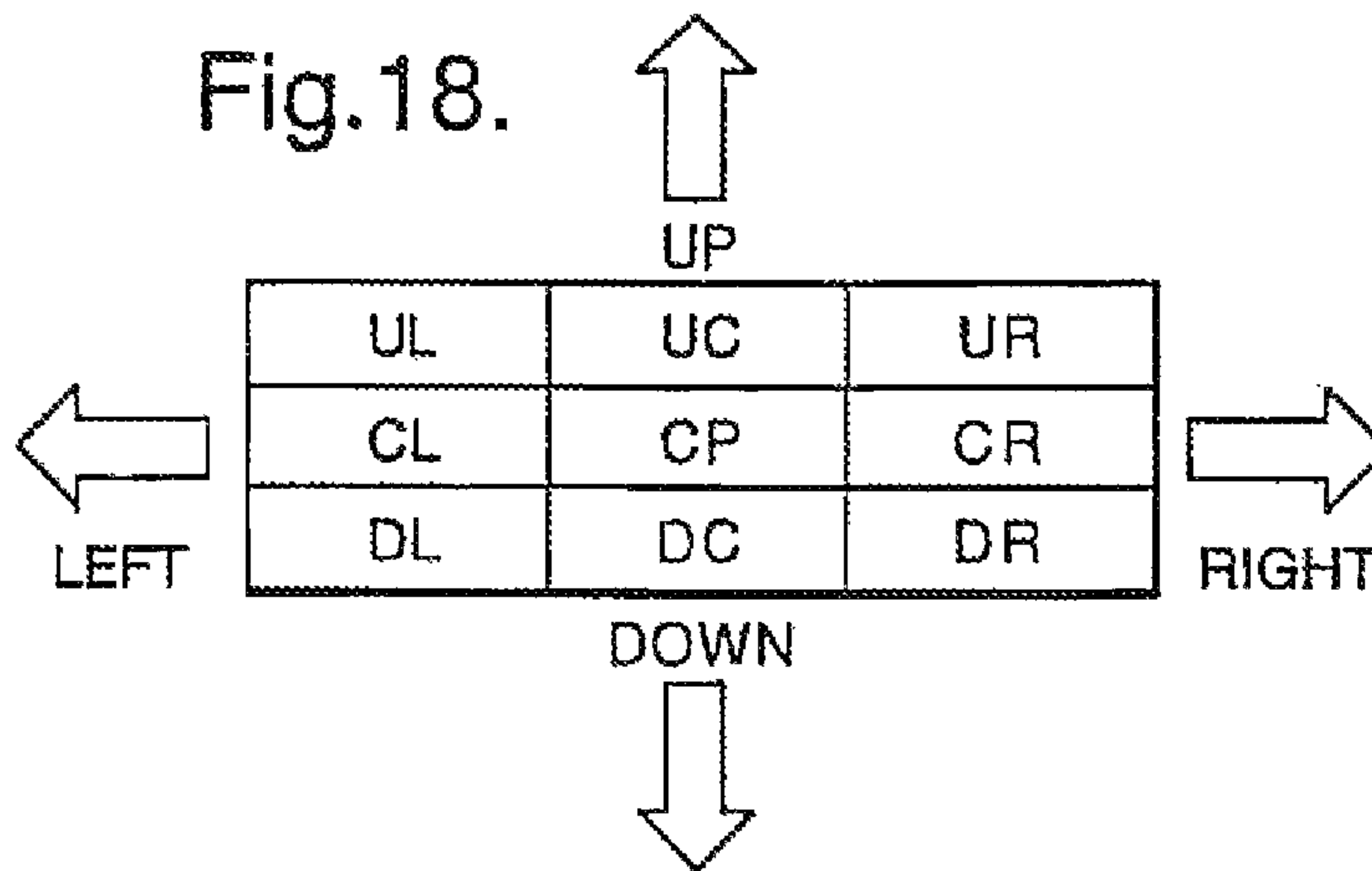
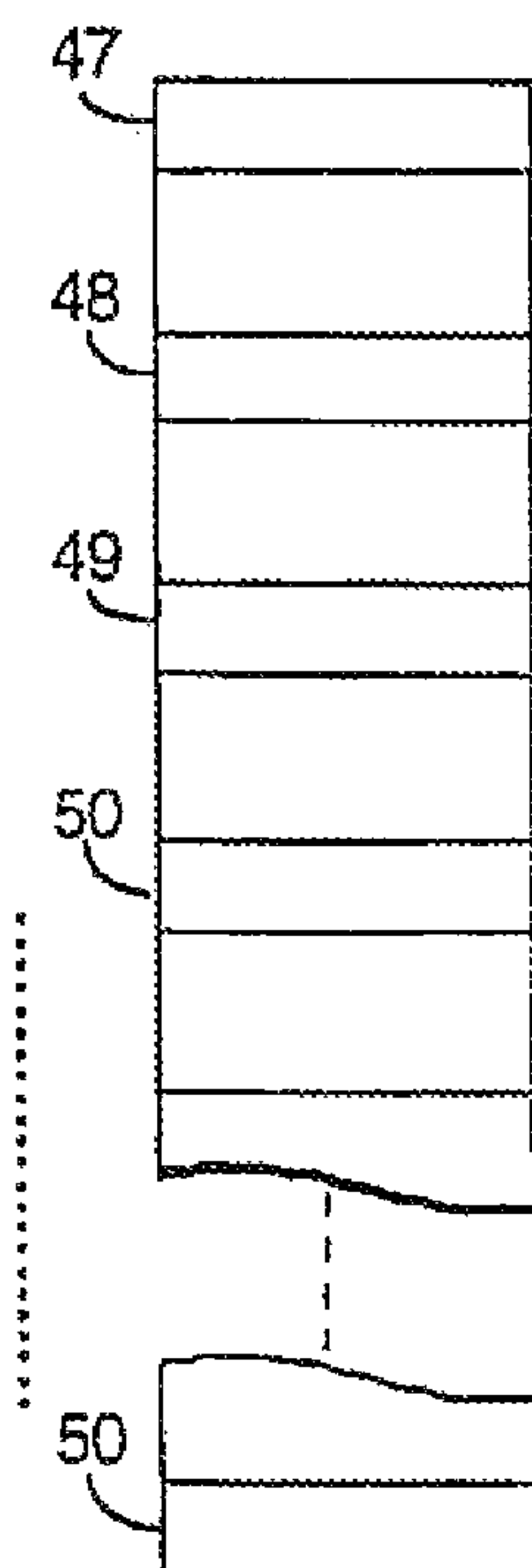

Fig. 19.



PORTABLE COMPUTERS

Matter enclosed in heavy brackets [] appears in the original patent but forms no part of this reissue specification; matter printed in italics indicates the additions made by reissue; a claim printed with strikethrough indicates that the claim was canceled, disclaimed, or held invalid by a prior post-patent action or proceeding.

CROSS REFERENCE TO RELATED APPLICATIONS

This application is a divisional broadening reissue application of broadening reissue application Ser. No. 13/188,239, filed Jul. 21, 2011, which in turn is a divisional broadening reissue application of Ser. No. 11/907,832, filed Oct. 17, 2007, now U.S. Pat. No. Re. 42,738; which in turn is a broadening reissue application of Ser. No. 09/171,921, now U.S. Pat. No. 6,956,564, issued Oct. 18, 2005; which is the 35 USC 371 National Stage Entry of International patent application serial number PCT/GB98/03016, filed Oct. 8, 1998, claiming priority of GB9722766.4, filed Oct. 28, 1997, the entire disclosures of which are herein incorporated by reference in their entireties; and is related to the following reissue applications: Ser. No. 12/255,557, filed Oct. 21, 2008; Ser. No. 12/268,254, filed Nov. 10, 2008, now U.S. Pat. Re. 44,103; Ser. No. 12/268,336, filed Nov. 10, 2008.

BACKGROUND OF THE INVENTION

1. Field of the Invention

The present invention relates to portable computers and more particularly but not exclusively to hand-held computers of the kind sometimes referred to as personal digital assistants.

2. Related Art

A personal digital assistant includes data files defining such items as an electronic diary, address book and other applications such as word processing software, calculators and the like. As more powerful memories and processors have been developed in smaller packages it has become possible to provide quite powerful computers in relatively small portable cases. However, the limitation of miniaturisation occurs when a viewing screen and keyboard are needed for data input and read out. Thus, so called palm top personal computers (PPC) are usually of the order of 15 cm by 7 cm in order to provide a readable screen and a usable keyboard. Such palm top computers are known, for example Psion Corporation have produced a Psion Series 5 (trade mark) PPC having an 8 megabyte RAM and processor while Hewlett Packard similarly produce PPCs as e.g. the HP320LX (trade mark). The capabilities of such PPCs may be enhanced by incorporating so called flash cards enabling the expansion of the RAM by up to 10 megabytes or more while PCMCIA cards may be provided to enable connection of the PPC to telephone networks by way of cellular phones or telephony sockets for communication with other computers and the so called Internet and Intranets.

Most PPCs incorporate a docking arrangement to enable them to be connected with a desktop computer or other main frame for the purposes of synchronisation of data files and the like.

However, generally speaking PPCs are not robust and are prone to damage mainly because of the clam shell design requiring a hinge that opens to reveal the incorporated key-

board and screen. Thus PPCs are more usually used on a desk top or table or may be held in one hand while typing with the other.

SUMMARY OF THE INVENTION

According to the present invention there is provided a portable computer including movement detection means responsive to movement of the computer to produce an electrical output signal representative of such movement, processing means responsive to the output of said position detection means to determine detected movement data defining a user's intention, the processing means using said data to provide a mode response selected from a multiplicity of stored possible modes.

Preferably the movement detection means includes at least one acceleration or tilt detection means responsive to movement of the computer to produce the output electrical signal. There may be a plurality of acceleration detection means each producing a respective electrical output signal representative of movement components in respective directions, the detectors generally being mounted to detect X and Y movement components at a ninety degree angle.

The processing means may include a data input mode in which detected movement data is used to generate alphanumeric or graphical data. The alphanumeric or graphical data may be stored in data storage of the portable computer or may be output by transmitting means to receiving means connected to another processing device.

The processing means may include a screen output mode in which detected movement data is used to modify output to display means of the computer whereby scrolling of displayed information is effected. In the screen output mode the processing means may be responsive to relative lateral tilting movement to cause the display of information stored as to one or other side of currently displayed information. Relative rolling movement may cause the display of information stored as above or below the currently displayed information.

In the screen output mode the processing means may be responsive to detected movement data to determine a most likely orientation of the computer display means with respect to a user's eye line whereby the signals output to the display means may cause inversion of the displayed information such that the computer may be held and used in either hand.

The computer may include proximity detection means arranged to provide signals indicative of the proximity of the display screen to a user's view, the processing means being responsive to changes in the relative proximity to increase or decrease density of displayed information.

In a further development, security data derived from movement of the computer defining an authorised user's password is stored, the processing means being locked in a secure mode until detected movement data corresponding to the security data is received.

The computer may include a sound input device, the processing means having a second data input mode in which alphanumeric data is derived from input speech signals. A sound output device may also be included to permit the output of speech derived from stored data. Alternatively the sound input and output devices may be combined with a radio transceiver whereby cellular or other radio telephony networks may be used.

The computer may be housed in a casing shaped to facilitate a user holding the computer as if holding a writing stylus. The casing is preferably of substantially radiused triangular cross section along a substantial portion of its length and may include a flattened section incorporating a display screen. The

3

casing may include angular shaping between a forward holding area and a rearward screen area the shaping being such as to provide a natural viewing angle of an incorporated display screen while the casing is held as a writing stylus. The shaping may also be such as to facilitate support of the rearward screen area by the dorsal aspect of a user's hand between the root of the thumb and index finger and the wrist.

BRIEF DESCRIPTION OF THE DRAWINGS

A portable computer in accordance with the invention will now be described by way of example only with reference to the accompanying drawings of which:

FIG. 1 shows a plan view of the computer;

FIG. 2 shows a side view-of the computer of FIG. 1;

FIG. 3 is a block schematic diagram of the circuits of the computer of FIG. 1;

FIGS. 4a and 4b provide a circuit diagram showing details of the circuitry described with respect to FIG. 3;

FIG. 5 is a circuit diagram of a docking station to enable the computer of FIG. 1 to be connected to a desktop or other device;

FIGS. 6 to 9 are flow charts showing some of the programs incorporated in the microprocessor of FIG. 4;

FIGS. 10 to 13 are graphical representations of the outputs of the accelerometers of FIG. 4 as analysed by the microprocessor;

FIGS. 14a and 14b provide a graphical comparison of the representations of the outputs of the accelerometers as shown in FIGS. 10 to 13;

FIG. 15 is a schematic diagram of a power saving arrangement of the portable computer of FIG. 1;

FIG. 16 is a schematic diagram of a voice input arrangement of the portable computer of FIG. 1;

FIG. 17 shows mounting positions of the accelerometers of FIG. 4 with respect to each other;

FIG. 18 is a table showing a program response to movement of the accelerometers of FIG. 16 in a particular mode of operation; and

FIG. 19 is a schematic diagram of a part of a scroll detector of the portable computer of FIG. 1

DETAILED DESCRIPTION OF THE EXEMPLARY EMBODIMENTS

Referring to FIGS. 1 and 2, the hand-held computer of the present invention has a case 1 of a moulded plastics material having a triangular barrel cross section towards the forward end, that is towards the point, with radiused sides providing a diameter of approximately 15 mm. The case is shaped to have a curve so that when the forward part of the barrel of the casing is held as a writing stylus using the thumb, index finger and second finger of the user, the screen area A—A rests comfortably on the dorsal area at the back of the hand between the root of the thumb and index finger of the hand and the user's wrist. This provides some additional support to allow the entire computer to be operated using one hand only. After assembly the case is sealed using an O-ring seal much in the manner of sealing watch parts. Coating the casing with wax polythene completes the sealing of the unit so that to all intents and purposes the case is waterproofed.

The casing is weighted at one end (for example by including a rechargeable battery 2) at the forward end so that if the item is dropped on to a surface it tends to fall in a specified manner such that the tip which may include some impact protection, for example by being rubber cased, prevents any

4

significant damage to internal components. The weighting also assists balancing of the unit in a user's hand.

The case may incorporate a hook 3 for attachment of a strap or key ring (not shown) and may have a pocket clip 4. The hook is preferably recessed within the casing.

Externally mounted a small liquid crystal diode screen which may be of the kind manufactured by Batron and supplied under type number BT42003STYC is included. To either side of the LCD 5 touch or pressure sensitive switches 6 to 13 are provided. These switches may be soft programmed to provide functions as hereinafter described. A touch scroll strip 14 (hereinafter described) is provided in front of the screen 5 and the system includes a pyroelectric detector 15 used in determining the proximity of the computer to a user's eye.

Audio input and output devices are also provided together with an alerting device. For example, a microphone 16, annunciator 17 and speaker 18 may be included. Finger switches 19a, 19b, 20 are provided forward of the annunciator 17 and again may be soft programmed for functionality. Also visible are gold docking pins 21 used for connecting the hand-held computer for recharging of the battery 2 and transfer of data by way of a docking device to other computers, for example desk mounted personal computers.

As an alternative means of transferring data from the computer of the invention to another processing device or to enable the computer of the invention to be used as an input device for a PC, an infrared transceiver 22a, 22b is mounted towards the front of the casing 1.

Also included is a light emitting diode 23 which may be of the kind having three or more colours. Individual colours allow for a small amount of illumination or may be used to provide indication or alarm functions. Alternatively, a single coloured red light emitting diode part TLSH180P from Toshiba may be used. This ultrabright LED aids human night sight viewing and whilst only being of low power may in a dark environment assist the user.

Turning now to FIG. 3, a block schematic diagram of the component parts of the computer is shown. It will be noted that the display 5 receives inputs from a microcontroller 30 which may be of the type supplied by Microchip under the reference PIC16C74. The PIC16C74 includes on board read only memory (ROM) but in a preferred embodiment an ARM processor with a larger memory is used. Also mounted within the casing 1 are two accelerometers 31, 32 which may be of the kind known as ADXL05 from Analog Devices Limited and which are buffered by operational amplifiers, for example National Semiconductor type LPC662. The keys 6 to 13 and 18 to 20 are here represented as a keypad 33. Some of the keys may be used to control a speech recorder 34 which is also used as an interface between the microcontroller 30, and microphone 16 and the speaker 18. A radio transmitter 35, which may be a radio transceiver, is also incorporated.

One function of the radio transmitter may be to allow use of the hand-held computer of the invention as an input device for a desk mounted or other PC 40 having corresponding receiver 36 and an appropriate converter without physical interconnection. Other functions of the transceivers 35, 36 may be apparent from the description hereinafter.

Referring now to FIGS. 4a, 4b the microcontroller 30 is connected to the display 5 using standard control inputs of the display to provide a visual output of the result of program activities requested by the user. It will be noted that the accelerometers 31 and 32 have associated buffer circuits which each include an operational amplifier to buffer the input to the microcontroller. The operational amplifiers 41 may be type LFC662 from National semiconductor.

5

Power to the accelerometers **31** is by way of a transistor **TR2** so that if the microcontroller **30** determines that no movement of the computer is occurring or that the present program does not require use of the accelerometers **31** and **32**, output **RB1** may be set to stop current being drawn to mini-
5 mize battery usage. The microcontroller may allow periodic sampling during dormant periods so that if the computer is picked up the sensors may again be activated.

An EEPROM integrated circuit chip type X24F064 8 Kbyte from Xicor providing 8 Kbytes of memory is also provided accessible from the microcontroller **30** in known
10 manner. Switches **S1** to **S8** (keys **33** in FIG. **3**) are wired to respective inputs of the microcontroller **30**.

Note that **TR1** controls power input to the back lighting circuitry of the LCD display **5**. Again, the microcontroller **30** will normally bias **TR1** off when the computer is dormant and will maintain **TR1** biased off unless back lighting is requested
15 by operation of one of the keys of the keyboard **33**.

For the avoidance of doubt it is here noted that the microcontroller **30** includes a program which uses position outputs from the accelerometers **31**, **32** to determine from the orientation of the computer whether the hand-held computer is in the left hand or right hand of the user. It is here noted that accelerometer output may depend upon the tilt angle of the included accelerometers to the earth's gravitational field. The keys **S1** to **S8** are then swapped over in soft programming mode such that functionality is determined by the apparent top of the display **5** to the user in its current position. Similarly, determination of orientation of alphanumeric or other display information on the screen **5** will be determined from the orientation of the computer itself. Thus, data output to the screen from the controller **30** arranged to provide an appropriately oriented display.
20

The speech recorder **34** is implemented using Sequoia technology sound recording integrated circuit type ISD2560. The Sequoia technology chip is capable of recording 60 seconds of speech message in digital form and is connected so that the microphone **16** can be used to provide an input. The three switches **SW1**, **SW2** and **SW3** may correspond to the fingertip switches **18** to **20** of FIG. **1** or may be selected in software from keys **6** to **13**.
25

In speech recording mode **SW1** provides a start and pause control function for the user, **SW2** is a stop or reset function while **SW3** switches between the record and play modes.

Short messages are played back by way of the loud speaker **18**. As currently implemented the microphone **16** is a Maplin type QY628, the speaker is from Hosiden type HDR9941. "Speech notes" recorded by this method may be down loaded to a PC for sorting and categorising.
30

Turning briefly to FIG. **5**, the hand-held computer of FIG. **1** can be inserted in a corresponding docking port shaped to align the contact **21** with **T5** to **T7** of FIG. **5**. The contact **T5** and **T8** provide serial receive and transmit paths for synchronising databases between a PC and the portable computer and also provide battery charging. Contact **T7** provides an earth contact. Speech samples and other data may be up loaded from a PC to the portable computer.
35

A Maxim integrated circuit **42**, which may be type MAX232IC, converts RS232 level serial output and input required by current PCs to the voltage level required by the microcontroller **30** of FIG. **4**. Note also the ability to receive radio input by way of an antenna connected to the radio receiver chip type AMHRR3-418.
40

Having discussed the hardware of the portable computer of the invention we shall now consider various uses to which the writing stylus input, voice input and screen may be used. Exemplary flow charts for some aspects of the use of the
45

6

portable computer are attached. While functions are individually discussed in respect of the flow charts of FIGS. **6** to **9**, it will be appreciated that combinations of programs may be used in the implementation of features described hereinafter.

Turning now to FIG. **6**, the tilt sensor software uses inputs from the accelerometers **31**, **32** which, as shown in FIG. **17** to which reference is additionally made, are mounted with their respective sensitive axes at right angles to each other. As will have been seen from FIG. **4**, the output from each accelerometer is filtered by a resistor capacitance network to remote high frequency noise for example, and the outputs are then read by an analogue to digital converter included within the microcontroller **30**. Thus, referring to FIG. **6**, for special sensing the microcontroller **30**, display **5** and analogue to digital conversion circuits are initialised at **100** and the interrupts and port pins of the microcontroller **30** are reset or cleared at **105**. The output of the accelerometers **31**, **32** is read from respective analogue input pins **AN0** and **AN1** of the microcontroller **30** and an index to a look up table is calculated at step **110** using the formula $I=a+(b1 \times 16)$. In this case **a** is calibration constant and **b1** is the digitised output of the accelerometer **31**. This allows for a look up table allowing a **16** by **16** matrix of left to right position to be determined. For vertical tilt position the formula $I=a+(b2 \times 16)$ where **b2** is the output of the accelerometer **32** may be used to address a further matrix to determine the relative up/down position. By applying one or more of the indices to the look up table, it is possible to select one of **n** screen positions or to determine the amount of movement since the last reading at step **115**. The system then waits for 10 ms as indicated at step **120** before repeating the reading of the accelerometer output.
45

The program allows for the screen **5** to be scrolled in accordance with the user's requirements. The mounting of these sensors, as shown in FIG. **17**, allows positional movement such as up, down, left and right to resolved to fractions of a degree.

Using software the microcontroller **30** may use the output from the accelerometers **31**, **32** to determine a user's requirement for a different view to be displayed on the screen **5**. Thus a virtual hinge is created such that if the user moves the stylus whilst it is in viewing position the screen information may be changed to respond to a natural reaction for looking up or down or to the left or right. Thus, as shown in FIG. **18** in a simplified arrangement, if the display on the screen at any time is designated as current page (**CP**) then tilting the stylus towards the left will cause the display of a page stored as to the right of **CP** (**CR**). The page which was formerly **CR** (as represented by data held within the storage of the microcontroller **30** or an associated data store) is now **CP**. Tilting the stylus to the right will cause a page of information (**CL**) to the left of **CP** to be displayed. For the avoidance of doubt the term page is used here as for a screen for information. Thus the action of tilting the stylus to the left or right is analogous to the natural inclination to look through a window towards the right or left to obtain additional information from a scene.
50

Similarly, if the stylus is turned towards the user information stored at **UC** will be displayed and tilting the stylus away results in the information **DC** being displayed. It will be appreciated that combining tilt angles may result in the display of information up and to the left (**UL**), up and to the right (**UR**), down and to the left (**DL**) and down and to the right (**DR**). This simplified description of a multiple line screen moving as if a jump is occurring should be considered as allowing single line scrolling in which **CP** defines the top line of the screen, **DC** the line below and further lines to the limit of screen viewability also being displayed with **CP** such that single line scroll movement or smooth scrolling appears to
55

occur. Finer scrolling modes such as single pixel movements are also possible. The user may select the rate of response using keys **6** to **13** or fingertip switches **18** to **20**. It should also be noted that the tilt sensor arrangement **31**, **32** allows the microcontroller **30** to determine the most likely viewing angle and to adjust pixel mapping to the screen accordingly so that if a user holds the stylus in the left hand the display is inverted to that shown in FIG. **1** so that the bottom right corner, as viewed by a right handed user, becomes the top left corner as viewed by a left handed user. It should be noted that the microcontroller does not require an input from the user to determine whether the stylus is being held in the left or right hand and, if a user changes hands during the course of viewing the screen output will be inverted accordingly.

It is also possible, particularly if pictorial rather than alphanumeric display is required, for the screen to enter a "portrait" mode if the stylus is held vertically. In this case the orientation will be appropriate to the stylus being held with its tip above or below the waist of the stylus.

To prevent scrolling or orientation change the user may use a soft key **6** to **13** or fingertip switch **18** to **20** to lock and unlock display movement.

Further, while as described with reference to FIG. **3**, the display screen is a Batron, in a preferred embodiment a Kopin Cyberdisplay **320** having $\frac{1}{4}$ VGA colour resolution may be used. Using the Kopin display and the associated monocular viewing lens mounted end on to the body allows clear viewing of some 15 lines of normal text. The Kopin Monocular lens is approximately 20 mm by 18 mm which gives an acceptable size to a pen body incorporating movement sensing means as herein described.

In a still further development the pyroelectric detector (Murata type IRA- E700STO) **15** may be used to detect the presence of the user and the proximity of the user to the viewing screen **5**. Using the Kopin $\frac{1}{4}$ VGA display it is possible to decrease the size of character displayed. Thus the microcontroller **30** uses the output of the pyroelectric detector **15** to determine how close to a user's eye the stylus is held and may adjust the size of print so that more characters are fitted on the screen **5**. In this way large areas of text may be read by holding the screen close to the user's eye. A further use of the pyroelectric detector for power saving purposes it discussed hereinafter. As has been mentioned detection of the position of the screen with respect to the user's left or right side is possible.

Referring to FIG. **8**, clearing of interrupt and set port pins and initialisation as previously mentioned with regard to FIG. **6** is carried out. One of the accelerometers, for example the accelerometer **31**, is read at step **200** and its value compared with a predetermined value m . Values greater than m indicate that the display is most likely in the user's left hand so that as indicated at **215** inverted characters are displayed on the screen **5**. If the value read from accelerometer **31** is less than m then it may be assumed that the stylus is in the user's right hand and normal ROM LCD characters are displayed. As indicated at **220**, a check may be carried every 10 ms to determine the whereabouts for the screen.

It is envisaged that input to the computer system either for use as a PDA or for word processing purposes, will be carried out either by hand writing recognition (HR) or by voice input using the microphone **16**. Handwriting recognition does not require the user to write on a surface, although some users may find this a preferable method of operation, but requires the user merely to move the stylus (that is the whole computer) as if writing letters and numbers. Katakana or Cyrillic texts may also be entered as may symbols.

Thus using one of the two accelerometers **31**, **32** and referring to FIGS. **10** to **14**, the output of one of the accelerometers **31**, **32** is read at a simple rate of 100 times per second. The received data is stored in a random access memory (RAM) buffer as a set of acceleration values against unit time. Using a software process of autocorrelation the microcontroller **30** may determine the character entered. Thus, referring to the Figures, FIG. **10** shows three entries of the letter C, FIGS. **11** shows three entries of letter B, FIG. **12** entries of letter F and FIG. **13** three entries of letter H for exemplary purposes only. Feedback to the user either on the display or by character speech output or simply by an acoustic beep indication may be used to note acceptance of a character. The validity indication may be user selectable.

It will be noted from FIG. **14** that a single accelerometer output is distinct for each of the input characters and therefore the microcontroller can determine the entry made. The entry may be of text which can be reflected to the viewing screen **5** or maybe instructions couched in appropriate terms such as "get Monday diary". Once the diary has been recovered from the store the appropriate entries may be displayed on the screen **5** with appropriate soft key indications for the keys **6** to **13**.

Note that predefined user gestures such as drawing an "envelope" to request e-mail mode or a table for diary mode, for example, may be used. The instructions may be user selectable or teachable so that on initialisation the user draws and selects the mode. Subsequently drawing the same symbol will cause the microcontroller **30** to enter the appropriate selected mode.

Again sensing may be used to move around the displayed area (as discussed with reference to FIG. **6** and FIG. **18**) or the touch strip controller **14** may be used in combination with the keys **6** to **13** to select appropriate areas.

Entry of information to the diary may also be by handwriting input. It is convenient here to consider the construction of the touch strip **14** which as shown in FIG. **19** comprises a 0.4 mm printed board having a surface area of approximately 20 mm by 5 m with horizontal strips in the 5 mm dimension as indicated as **47** to **50** for FIG. **19** which shown a part of the strip **14**. The strip **14** thus replaces the rotational elements of potentiometer so that hermetic sealing of the casing may be complete and a control which is resistant to wear as provided. The strips **47** to **50** etc, are interfaced to the microcontroller **30** so that as a finger is moved across the strip direction of movement and speed of movement may be determined. The information may be used in the same way as a rotary potentiometer.

It will be appreciated that incorporating a second strip at right angles to the strip **14** would allow full functionality of (eg) a computer mouse to be simulated.

Thus as shown in FIG. **19**, if a user moves a finger such that, for example, the presence of the finger bridging **48**, **49** and **50** subsequent to the presence of a finger bridging **47** to **50** indicates that the user would wish to rotate a potentiometer in a counter-clockwise direction. Similarly, detection of a finger bridging **47** and **48** subsequent to there having been no previous bridge indicates rotation in a clockwise direction.

It will be appreciated, however, that if the tilt detection mechanism hereinbefore described indicates that the device is in the left hand rather than the right hand the functionality of bridging and unbridging is reversed accordingly.

Entry of data files, for example the composition of letters or reports can be carried out using either the write sensing arrangement, hereinbefore described, to determine input alphanumeric which may be stored for subsequent transmission to a printer or for transfer as data files to a PC for

example. Data entered and converted into appropriate stored information may be displayed on the display screen if required.

Cursor movement around the display screen to select a position to which information is to be placed may be by use of either the potentiometer arrangement described with reference to FIG. 19 or by use of the tilt sensing mechanism hereinbefore described in combination with one of the soft keys to indicate that an insert or delete position is being selected.

In an alternative method of operation and referring to FIG. 7a and initially to FIG. 7b, use of the stylus of FIG. 1 as a non-connected input device for a PC allows all of the functions of the hand held computer to be duplicated. For example, where alphanumeric data is input in the manner previously described with reference to FIGS. 10 to 14 a more powerful PC may be able to effect autocorrelation much more rapidly than the microcontroller 30 of the device itself. In this case, referring specifically to FIG. 7b, once the initialisation process has been completed at 100, one or both of the accelerometers may be read at 705 at 10 ms intervals as indicated at step 710 and the voltage data is transferred to the serial port for transmission by the wireless link or by use of infrared transmission.

A corresponding program in the PC itself will read from radio receiver 36 and the receive port the data defining the voltage from one, or both the accelerometers. Autocorrelation will be carried out on the reading to generate appropriate characters at step 725, the characters being displayed on the PC screen at step 730 and possibly being transmitted back to the hand-held PC.

In an alternative implementation autocorrelation may be carried out within the microcontroller 30 and data defining input characters themselves be transmitted to the PC.

Note that the transmission of comma separated variables (CSV) format ASCH is transmitted at 418 MHz using an amplitude modulated radio transmitter from RF Solutions of Lewes East Sussex UK. In the PC CMOS voltage levels converted by the RS232 conversion unit can be used to provide raw data to the PC. Windows 3.1 terminal software is capable of reading CSV data and spreadsheet can read and plot data graphically.

In a still further use of the accelerometer 31, 32 arrangement password protection of the hand-held computer may be provided. Thus, once trained to a user's signature, for example, a stored waveform corresponding to accelerometer voltage outputs read at 10 ms intervals can be used. Thus the user does not require to remember any special passwords and cracking of the signature code is extremely difficult since, for example forging a signature will result in a different acceleration pattern to that of the natural signature writer.

Thus it may be possible to use a hand-held computer of this nature to provide transmission of security information for, for example, electronic point of sale authorisations, access restriction and the like.

A still further use of the transmission and reception capability allows a local area paging system to be developed. Thus if several users work in reasonable proximity to each other it is possible to transmit a message directly from one hand-held computer to another such that, for example, telephone messages taken by one person in an office and files created may be transmitted using a digital serial identity to another specified hand-held computer unit.

Turning to FIG. 16, in addition to the simple 60 second voice note storage chip 34, the microphone 18 may also be connected by the amplifier and filter arrangements to provide voice input to the microcontroller 30. Voice recognition soft-

ware can thus be used to convert the voice input to data, the keys or fingertip switches 18 to 20 having appropriate use for pause, record, etc as hereinbefore described with reference to the spoken memorandum chip. Converted data can thus be transferred to the memory or displayed on screen or as hereinbefore described with reference to using pen input for handwriting correlation by a PC serial data to the PC representing the voice input can be provided. This is indicated at 39.

In an alternative method of working, the microcontroller causes storage of the speech input in the memory 38 without effecting conversion, the information being transmitted via the serial output port either in the docking station or by the radio link to a PC which may use voice recognition software to carry out the conversions. It may be preferable to use a PC to carry out the conversion rather than a microcontroller incorporated in the pen since significant processing power may be required. However, the inclusion of voice recognition software in the microcontroller 30 is possible.

It will also be realised that a data store may be used to store received speech signals. Thus several speech notes each time/date stamped may be held for subsequent use. If a suitable store is included then the speech storage chip, hereinbefore described, may be omitted from the stylus to allow additional memory chip space.

It will be noted that since the hand-held computer of the invention includes microphone, loudspeaker and function keys use of the device as a cellular telephone is also envisaged.

Where cellular phone functionality is included within the stylus or where the stylus is in contact with a PC for example by IRDA or radio transmission, the use of the microphone input for substantial dictation purposes is possible and also the use of substantially larger data files than could otherwise be stored locally.

Thus the input speech will be stored in a buffer by the microcontroller 30 and periodically, when the buffer contains a substantial amount of data, a network connection to either network data storage means or to a predetermined PC is effected. Stored buffered data is then transferred to the remote location. Since the network connection is not permanently required the cost of transferring the data by this means is less significant and periods of network signal weakness can be overcome.

Data buffered in this manner may be date and time stamped or, if the stylus incorporates GPS (global positioning systems) may be location stamped also.

Data may similarly be recovered such that large text documents required by a user may have portions stored in the buffer for display and sequential recovery of other parts of the document from the remote location using telephony as required. Photographic data, for example from a digital camera, may similarly be saved to the network by way of the buffered store.

The various functions above described enable the provision of a full PDA function including diary alarm and scheduling functions as well as data input, file creation and storage. The user may select the mode of operation using either soft buttons or movement input and the use of the accelerometers 31, 32 is determined from the mode selected by the user. Electronic mail and fax facilities may be incorporated in the PDA functions allowing reception or transmission of data via the unit. The transmission capability of the unit may be associated with a receiver in a printer for example or a printer incorporating a docking station may be used to allow the printing of data from the PDA. Note that infrared transmission may be used.

As will be appreciated one of the major problems with any hand-held portable device is the use of rechargeable batteries which have a limited power life between charges. The hand-held computer of the present invention therefore incorporates a number of power saving facilities arranged particularly to close down back lighting of the small LCD screen **5** if it is not appropriate. Thus if the accelerometers indicate that there is no current usage of the system then powering down of the detection circuitry and back lighting of the screen may occur. However, in a further use of the proximity detector **15**, it is possible to turn back lighting on and off in dependence upon whether the user is looking at information on the screen or not. Thus, referring to FIG. **15**, the pyroelectric detector conversion detects presence of movement to maintain back lighting. Pyroelectric detectors tend to detect presence of a person by movement through a parallel beam of infrared such that when movement is detected across a Fresnel lens an AC signal is generated.

Thus the pyroelectric system can be used to detect the presence of a user and in the absence of use power down of the back lighting at least may occur. Infrared sensors may similarly be used to detect the presence or absence of body heat. Note the pyroelectric detector, as previously described, can be used to control the character zoom feature hereinbefore described. A suitable detector is a Murata type IRAE700STO.

In a further implementation of back lighting power down which is responsive to the viewer's vision in addition to the viewer's presence. It is known that when a subject looks directly at a lens and a flash occurs blood vessels at the rear of the eyes reflect back to the camera. It is thus possible to periodically flash a low level light and to sense red reflection using a photodiode sensor. Thus as shown at FIG. **15**, the microcontroller **30** periodically causes an LED **60** to pulse. At the same time a photodiode **61** is monitored and, assuming presence of a user's eye **62** reflecting light from the pulse, the LCD will remain back lit as indicated at **58**. It is further noted that a custom-built solar cell (not shown), for example a Solarex available from Farnell Electronics, may be used to assist triple charging of the battery **2**.

If a user is not looking directly at the screen at the time the LED **60** is flashed there will be no reflection and the photodiode **61** will not activate. The microcontroller may therefore power down the back light **58** thus reducing the drain on the rechargeable battery **2**.

Although the present invention has been described with reference to a particular implementation using accelerometers other position detection and location means may be used to implement movement detection arrangements. While herein references made to alphanumeric data it will be appreciated that katakana character and Cyrillic script inputs may also be detected using the acceleration method hereinbefore described.

Note when the hand-held computer is docked with a PC or is receiving data by way of cellular or radio transmission it is possible to display received information on the screen **5**. Thus as indicated at FIG. **9** an initialisation message is output to the screen **5** and an appropriate buffer is cleared. As characters are received at the serial port they are transferred to the microcontroller at **905** and checked for frame validity at **910**. Assuming that there is no error at **910** and that the received character is not a clear screen message as indicated at **915** then a character is transferred to the LCD **5** for display at **920**.

Further possible uses of the portable computer of the invention include storing large numbers of speech modes which when down loaded to a PC with the pen either in a docking station or by IRDA or radio transmission are sorted. In this process the PC converts the each of the speech notes to text

and scans the text for frequently occurring words, for example "meeting" and then sorts the stored notes into sub-directories. Alternatively, notes may be sorted by date, subject matter or size as will occur with a normal windows file. Key control words such as "alarm" may result in the speech note being converted into a timed alarm which may then be written back to the portable computer so that at the appropriate time the portable computer either announces the alarm or a vibrate to alert the user, the alarm being displayed as a text message. It will be appreciated that if a sufficiently powerful microcontroller is used in the pen then the speech to text conversion may take place in the portable computer unit. A suitable vibrating motor for use as a silent alarm can be obtained from Murata of Japan. Situating the annunciator towards the barrel of the pen near the tip improves transmission.

The microcontroller may cause audio feedback of the current position of the stylus, for example by causing sounds of flicking pages when the pen is tilted forward or back.

While most emphasis herein has been on the display of alphanumeric, Katakana or Cyrillic characters, graphic information may also be viewed. For example, a file holding pictures related to a person may include three dimensional picture of that person's face. By revolving or tilting the computer the view may switch from a front view to a profile aspect. It will also be appreciated that an atlas may be stored in the data store and maps may be rotated to align with the direction of travel for example.

Additional functionality may be introduced to the hand-held computer by including a touch screen in front of the display screen such that a stylus can be used to select text or to cause localised movement of a cursor.

An autolocate function may be built into the microcontroller such that if no movement, ie no change in tilt of either the enclosed accelerometers occurs for a selectable period, probably 24 hours, the unit will sound an alarm at periodic intervals so that the user can locate it.

Note that the tilt sensors included herein measure tilt with respect to earth's gravity by use of a small beam arrangement. Other position sensors may be included. Global positioning By satellite is also a possible method of detecting a change in the position of the portable computer.

In a symbol counted mode it is possible for a user to flick the pen either as a tick or a cross, for example, in relation to a submitted document. The number of ticks or crosses may be counted and the result accumulated and transferred to data store or accumulated in a spreadsheet to which the user may input names, titles and the like. The use of other symbols in anticipated.

While as hereinbefore described the security signature is by use of acceleration, a pressure detector may be incorporated into the end of the device to further increase security by measurement of the profile as well as the two dimensional or three dimensional spatial sensor.

As has been mentioned hereinbefore, a number of keys, switches and buttons are provided on the casing of the portable computer. In a further implementation an on/off switch may be provided operated by pressure on the "nib-end". Whilst such switch pressure is not used for detecting Input text per se, it may be used to turn functions on and off. This may be used in a normal writing mode, for example, touching the pen tip against a writing surface to turn on the accelerometer detection functions. Releasing pressure on the tip then stops the accelerometer signals being considered as potential input to be decoded.

Any of the other switches may be used in certain modes to turn on or off text detection, for example, or to stop screen scrolling for example.

13

Calculator functions in the portable computer may be provided simply by writing the numerals and appropriate mathematical symbols in the normal manner. The tilt sensor software will determine the numerals and characters entered and perform an appropriate calculation for display on the display screen.

A further function, for example for clock setting causes Display of an analogue clock face on the display means 5. Time changes may be entered by selecting an appropriate mode and moving the user's write. Tilt sensing is used to determine forward or backward adjustment of the time stored.

What is claimed is:

[1. A portable computer comprising:

movement detection means responsive to movement of the computer to produce an electrical output signal representative of such movement,

a storage medium for storing data defining a multiplicity of displayable pages each comprising of a plurality of lines;

a display having a corresponding plurality of lines to enable one of the multiplicity of pages to be displayed; and

processing means responsive to the output of said movement detection means to determine detected movement data defining a user's intention;

the processing means using said movement data to provide a mode response selected from a multiplicity of stored possible modes, at least some of which define selection for display of a further one of the pages from the multiplicity of pages, the further one of the pages being adjacent to a previously selected page being currently displayed;

wherein detected movement data is used to effect scrolling of displayed information such that portions of data defining alphanumeric or graphic information outside a currently displayed screen is selectable by the user, the scrolling of displayed information effectively displaying a part of an adjacent screen.]

[2. A portable computer comprising:

movement detection means responsive to movement of the computer to produce an electrical output signal representative of such movement;

a storage medium for storing data defining a multiplicity of displayable pages each comprising of a plurality of lines;

a display having a corresponding plurality of lines to enable one of the multiplicity of pages to be displayed; and

processing means responsive to the output of said movement detection means to determine detected movement data defining a user's intention;

the processing means using said movement data to provide a mode response selected from a multiplicity of stored possible modes, at least some of which define selection for display of a further one of the pages from the multiplicity of pages, the further one of the pages being adjacent to a previously selected page being currently displayed;

in which a relative lateral tilting movement causes the display of information stored as to one or other side of currently displayed information.]

[3. A portable computer comprising:

movement detection means responsive to movement of the computer to produce an electrical output signal representative of such movement;

14

a storage medium for storing data defining a multiplicity of displayable pages each comprising of a plurality of lines;

a display having a corresponding plurality of lines to enable one of the multiplicity of pages to be displayed; and

processing means responsive to the output of said movement detection means to determine detected movement data defining a user's intention;

the processing means using said movement data to provide a mode response selected from a multiplicity of stored possible modes, at least some of which define selection for display of a further one of the pages from the multiplicity of pages, the further one of the pages being adjacent to a previously selected page being currently displayed;

in which relative rolling movement causes the display of information stored as above or below currently displayed information.]

[4. A portable computer comprising:

movement detection means responsive to movement of the computer to produce an electrical output signal representative of such movement;

processing means responsive to the output of said movement detection means to determine detected movement data defining a user's intention;

the processing means using said data to provide a mode response selected from a multiplicity of stored possible modes; and

wherein the processing means is responsive to detected movement data to determine a most likely orientation of a computer display means, the processing means causing the displayed information to be oriented accordingly.]

[5. A portable computer as in claim 4, in which a plurality of switch means responsive to user action is included adjacent to the display means, the respective function of each of the switch means being oriented to match the orientation of displayed information.]

[6. A portable computer as in claim 4 further comprising a touch sensitive static potentiometer strip responsive to movement of a user's finger to simulate movement of a potentiometer, the orientation of said potentiometer reflecting the orientation of the displayed information.]

[7. A portable computer comprising:

movement detection means responsive to movement of the computer to produce an electrical output signal representative of such movement;

processing means responsive to the output of said movement detection means to determine detected movement data defining a user's intention, the processing means using said data to provide a mode response selected from a multiplicity of stored possible modes; and

proximity detection means which provides signals indicative of the proximity of a computer display screen to a user's view, the processing means being further responsive to changes in relative proximity to increase or decrease the density of displayed information.]

[8. A portable computer comprising:

movement detection means responsive to movement of the computer to produce an electrical output signal representative of such movement;

a storage medium for storing data defining a multiplicity of displayable pages each comprising of a plurality of lines;

15

a display having a corresponding plurality of lines to enable one of the multiplicity of pages to be displayed; and

processing means responsive to the output of said movement detection means to determine detected movement data defining a user's intention; the processing means using said movement data to provide a mode response selected from a multiplicity of stored possible modes, at least some of which define selection for display of a further one of the pages from the multiplicity of pages, the further one of the pages being adjacent to a previously selected page being currently displayed;

radio transceiver means, the processing means being responsive to detected movement data which identifies another device to cause the transmission of coded signals including a message for display.]

[9. A portable computer as in claim 8 in which the processing means is responsive to received encoded radio signals to activate a paging alert.]

[10. A portable computer as in claim 9, in which the page alert comprises a tone.]

[11. A portable computer as in claim 9, in which the paging alert comprises an operation of a vibrating means.]

[12. A portable computer as in claim 8, in which the processing means causes the display of a message derived from the information received.]

[13. A portable computer comprising:

a casing for housing other components of the portable computer, the casing being shaped to facilitate a user holding the portable computer as a writing stylus; and a display screen;

wherein said casing includes a radiused triangular cross-section along a substantial portion of its length and a flattened section incorporating the display screen, and an angular shaping between a forward holding area adapted to rest in the user's fingers and rearward flattened area holding the display screen the shaping being such as to provide a natural viewing angle of the incorporated display screen while the casing is held as a writing stylus.]

[14. A portable computer as in claim 13, in which the shaping causes the rearward screen area to be supported by the dorsal areas of a user's hand.]

[15. A portable computer comprising:

movement detection means responsive to movement of the computer to produce an electrical output signal representative of such movement;

a storage medium for storing data defining a multiplicity of displayable pages each comprising of a plurality of lines;

a display having a corresponding plurality of lines to enable one of the multiplicity of pages to be displayed; and

processing means responsive to the output of said movement detection means to determine detected movement data defining a user's intention;

the processing means using said movement data to provide a mode response selected from a multiplicity of stored possible modes, at least some of which define selection for display of a further one of the pages from the multiplicity of pages being the further one of the pages being adjacent to a previously selected page being currently displayed;

wherein the processing means is responsive to detected movement data to determine a most likely orientation of the display, the processing means causing the displayed information to be oriented accordingly.]

16

[16. A portable computer comprising:

movement detection means responsive to movement of the computer to produce an electrical output signal representative of such movement;

a storage medium for storing data defining a multiplicity of displayable pages each comprising of a plurality of lines;

a display having a corresponding plurality of lines to enable one of the multiplicity of pages to be displayed; and

processing means responsive to the output of said movement detection means to determine detected movement data defining a user's intention;

the processing means using said movement data to provide a mode response selected from a multiplicity of stored possible modes, at least some of which define selection for display of a further one of the pages from the multiplicity of pages, the further one of the pages being adjacent to a previously selected page being currently displayed;

in which a plurality of switch means responsive to user action is included adjacent to the display, the respective function of each of the switch means being oriented to match the orientation of displayed information.]

[17. A portable computer comprising:

movement detection means responsive to movement of the computer to produce an electrical output signal representative of such movement;

a storage medium for storing data defining a multiplicity of displayable pages each comprising of a plurality of lines;

a display having a corresponding plurality of lines to enable one of the multiplicity of pages to be displayed;

processing means responsive to the output of said movement detection means to determine detected movement data defining a user's intention, the processing means using said movement data to provide a mode response selected from a multiplicity of stored possible modes, at least some of which define selection for display of a further one of the pages from the multiplicity of pages, the further one of the pages being adjacent to a previously selected page being currently displayed; and

a touch sensitive static potentiometer strip responsive to movement of a users finger to simulate movement of a potentiometer, the orientation of said potentiometer reflecting the orientation of the displayed information.]

[18. A portable computer comprising:

movement detection means responsive to movement of the computer to produce an electrical output signal representative of such movement;

a storage medium for storing data defining a multiplicity of displayable pages each comprising of a plurality of lines;

a display having a corresponding plurality of lines to enable one of the multiplicity of pages to be displayed; and

processing means responsive to the output of said movement detection means to determine detected movement data defining a user's intention;

wherein detected movement data is used to effect scrolling of displayed information such that portions of data defining alphanumeric or graphic information outside a currently displayed screen is selectable by the user, the scrolling of displayed information effectively displaying a part of an adjacent screen.]

17

[19. A portable computer as in claim 18, including a sound output device, the processing means being arranged to provide output of speech or other sound signals derived from stored data.]

[20. A portable computer as in claim 18, including radio transmission or infrared transmission means, the processing means being responsive to detected movement data to output to the transmission means signals representative of the detected movement.]

[21. A portable computer as in claim 18, including radio transmission or infrared transmission means, the processing means being responsive to detected movement data to output to the transmission means signals representative of alphanumeric characters.]

[22. A portable computer as in claim 18, in which the processing means stores data defining an authorised user's password, the processing means being locked in a secure mode until detected movement data corresponding to the security data is received.]

[23. A portable computer as in claim 18, further comprising a sound input device, the processing means being responsive to voice input signals from a user to derive alphanumeric data.]

[24. A portable computer as in claim 23, further including a sound output device in combination with a radio transceiver whereby cellular or radio telephony networks may be used.]

[25. A portable computer as in claim 18 housed in a casing shaped to facilitate a user holding the computer as a writing stylus.]

[26. A portable computer as in claim 25, in which the casing comprises a radiused triangular cross-section along a substantial portion of its length.]

[27. A portable computer as in claim 26, in which the casing includes a flattened section incorporating a display screen.]

[28. A portable computer comprising:

movement detection means responsive to movement of the computer to produce an electrical output signal representative of such movement;

a storage medium for storing data defining a multiplicity of displayable pages each comprising of a plurality of lines;

a display having a corresponding plurality of lines to enable one of the multiplicity of pages to be displayed; and

processing means responsive to the output of said movement detection means to determine detected movement data defining a user's intention;

in which a relative lateral tilting movement causes the display of information stored as to one or other side of currently displayed information.]

[29. A portable computer as in claim 28 housed in a casing shaped to facilitate a user holding the computer as a writing stylus.]

[30. A portable computer as in claim 29, in which the casing comprises a radiused triangular cross-section along a substantial portion of its length.]

[31. A portable computer as in claim 30, in which the casing includes a flattened section incorporating a display screen.]

[32. A portable computer comprising:

movement detection means responsive to movement of the computer to produce an electrical output signal representative of such movement;

a storage medium for storing data defining a multiplicity of displayable pages each comprising of a plurality of lines;

18

a display having a corresponding plurality of lines to enable one of the multiplicity of pages to be displayed; and

processing means responsive to the output of said movement detection means to determine detected movement data defining a user's intention;

in which relative rolling movement causes the display of information stored as above or below currently displayed information.]

[33. A portable computer as in claim 32 housed in a casing shaped to facilitate a user holding the computer as a writing stylus.]

[34. A portable computer as in claim 33, in which the casing comprises a radiused triangular cross-section along a substantial portion of its length.]

[35. A portable computer as in claim 34, in which the casing includes a flattened section incorporating a display screen.]

[36. A portable computer comprising:

movement detection means responsive to movement of the computer to produce an electrical output signal representative of such movement;

a storage medium for storing data defining a multiplicity of displayable pages each comprising of a plurality of lines;

a display having a corresponding plurality of lines to enable one of the multiplicity of pages to be displayed; and

processing means responsive to the output of said movement detection means to determine detected movement data defining a user's intention;

wherein the processing means is responsive to detected movement data to determine a most likely orientation of the display, the processing means causing the displayed information to be oriented accordingly.]

37. *A hand held cellular telephone comprising:*

a case;

the case being unitary and without comprising a hinge;

the case being sized and shaped to be held within one hand of a user;

the case also containing a cellular transceiver;

the case also containing a processor;

a rechargeable battery also being housed within the case;

a display that displays information, the display disposed on the case;

the screen area of the display being of a size such that it extends between the root of a thumb and an index finger of a user and extending to the user's wrist;

a detector that generates data indicative of whether a user is looking at the display;

the display being powered by a rechargeable battery; and

the processor being configured to reduce power supplied by the rechargeable battery to the display based on the data generated by the detector.

38. *The hand held cellular telephone of claim 37, wherein the display comprises a touch screen.*

39. *The hand held cellular telephone of claim 37, wherein the housing comprises a molded plastic case which is sealed to make the case waterproof.*

40. *The hand held cellular telephone of claim 37, further comprising a light emitting diode.*

41. *The hand held cellular telephone of claim 40, wherein the light emitting diode may emit light of more than one color.*

42. *The hand held cellular telephone of claim 40, wherein the light emitting diode emits a red color.*

43. *The hand held cellular telephone of claim 37, further comprising configuring the hand held cellular telephone to*

perform multiple functions selected from the group consisting of at least one of: reception and transmission of email; storage and display of large text documents; diary alarm and scheduling functions; storage and display of maps; and storing and sorting speech notes.

5

44. The hand held cellular telephone of claim 43, wherein the at least one function of storage and display of large text messages comprises the storage and display of photographs.

45. The hand held cellular telephone of claim 43, wherein the at least one function is storage and display of maps.

10

46. The cellular telephone of claim 37, wherein the display comprises a liquid crystal display further comprising a backlight.

47. The cellular telephone of claim 46, wherein the processor is configured to reduce power to the liquid crystal display by closing down the backlight of the display.

15

* * * * *