



US00RE45521E

(19) **United States**  
(12) **Reissued Patent**  
**Frantz et al.**

(10) **Patent Number: US RE45,521 E**  
(45) **Date of Reissued Patent: May 19, 2015**

(54) **VLAN FRAME FORMAT**

(71) Applicant: **Spherix Incorporated**, Longview, TX (US)  
(72) Inventors: **Paul James Frantz**, San Francisco, CA (US); **Geoffrey O. Thompson**, Mountain View, CA (US)  
(73) Assignee: **Spherix Incorporated**, Tysons Corner, VA (US)

(21) Appl. No.: **13/728,747**  
(22) Filed: **Dec. 27, 2012**

**Related U.S. Patent Documents**

Reissue of:

(64) Patent No.: **6,111,876**  
Issued: **Aug. 29, 2000**  
Appl. No.: **08/705,631**  
Filed: **Aug. 30, 1996**

U.S. Applications:

(60) Division of application No. 12/459,465, filed on Jun. 30, 2009, now Pat. No. Re. 44,775, which is a division of application No. 10/225,708, filed on Aug. 22, 2002,

(Continued)

(51) **Int. Cl.**  
**H04L 12/28** (2006.01)  
**H04W 4/00** (2009.01)

(Continued)

(52) **U.S. Cl.**  
CPC ..... **H04W 76/021** (2013.01); **H04W 72/1242** (2013.01); **H04W 84/18** (2013.01)

(58) **Field of Classification Search**  
CPC ..... H04W 76/021; H04W 72/1242; H04W 84/18; H04L 12/00–12/467  
USPC ..... 370/310–469  
See application file for complete search history.

(56) **References Cited**

**U.S. PATENT DOCUMENTS**

5,220,564 A 6/1993 Tuch et al.  
5,394,402 A 2/1995 Ross

(Continued)

**OTHER PUBLICATIONS**

Draft Recommended Practice 802.1H, “Media Access Control (MAC) Bridging of Ethernet V2.0 in 802 Local Area Networks,” pp. 1-22, Jul. 7, 1994.

(Continued)

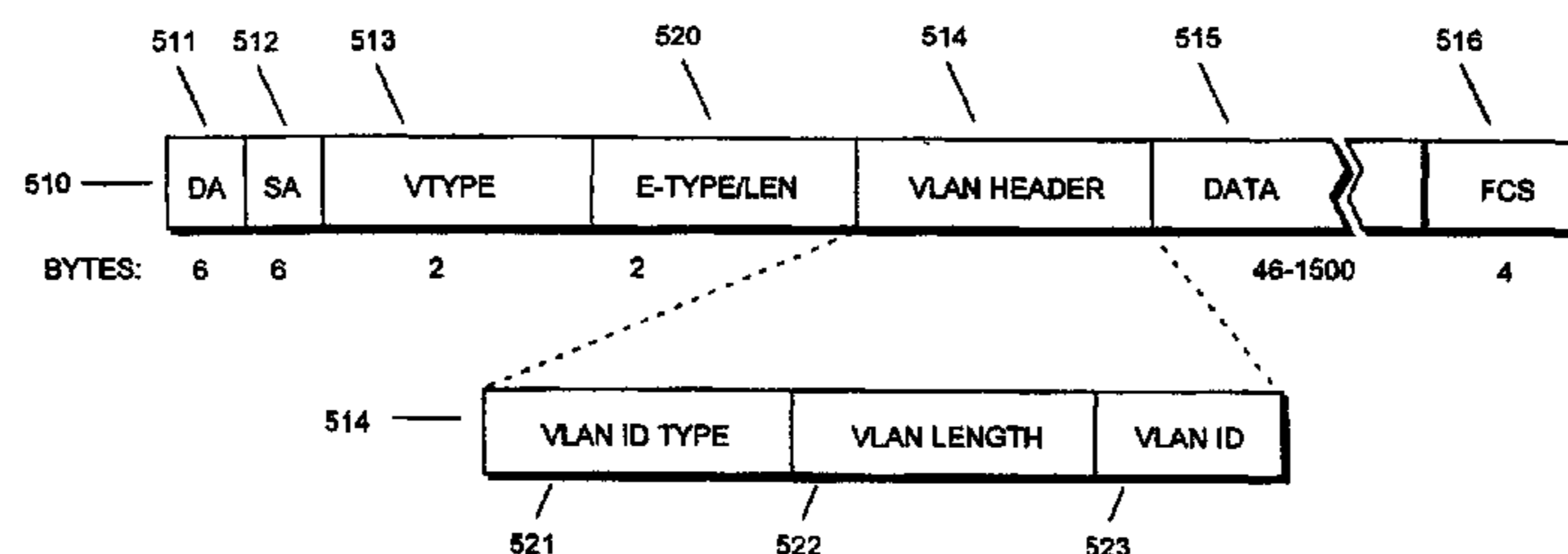
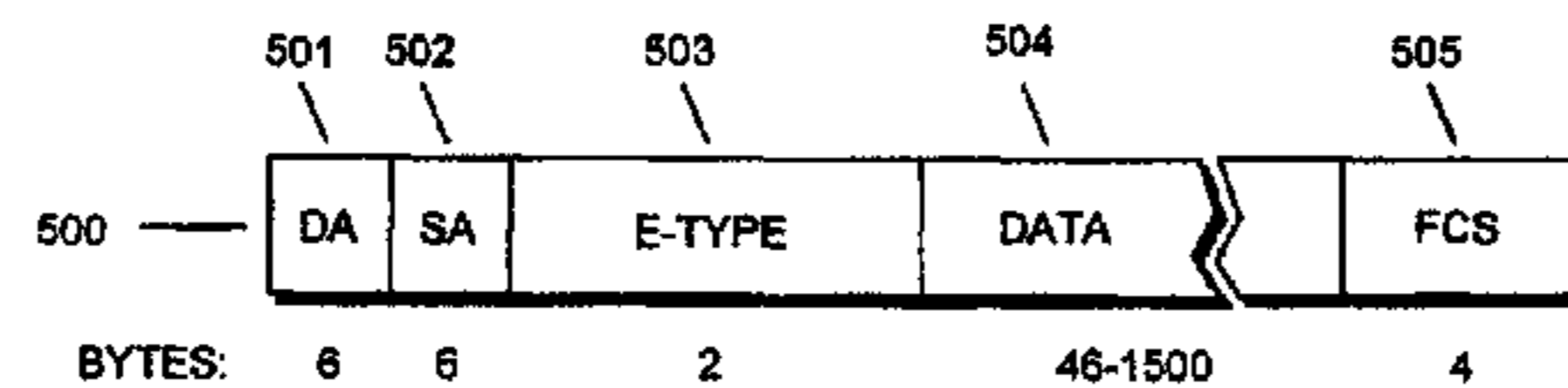
*Primary Examiner* — Afsar M Qureshi

(74) *Attorney, Agent, or Firm* — Mintz Levin Cohn Ferris Glovsky and Popeo, P.C.

(57) **ABSTRACT**

In a network device such as a network switch having a port coupled to a communications medium dedicated to a single virtual local area network and another port coupled to a communications medium shared among multiple virtual local area networks for transmitting data frames between the dedicated communications medium and the shared communications medium, a method of identifying the virtual network associated with each data frame received by the network switch when transmitting the data frames over the shared communications medium. The method comprises receiving data frames from the dedicated communications medium coupled to one port, and, with respect to each data frame so received, inserting a new type field and a virtual network identifier field. The contents of the new type field indicate the data frame comprises a virtual network identifier field. The method further includes placing a value in the virtual network identifier field identifying the virtual network associated with the data frame and transmitting the data frame over the shared communications medium. Upon receipt of the data frames from over the shared communications medium, another network device can discern from the virtual network identifier field in each data frame the virtual network from which the data frames were received and determine whether to forward the data frames accordingly.

**11 Claims, 7 Drawing Sheets**



**Related U.S. Application Data**

now Pat. No. Re. 40,999, which is an application for the reissue of Pat. No. 6,111,876, which is a continuation-in-part of application No. 08/613,726, filed on Mar. 12, 1996, now Pat. No. 5,959,990.

(51) **Int. Cl.**

*H04W 76/02* (2009.01)  
*H04W 72/12* (2009.01)  
*H04W 84/18* (2009.01)

(56)

**References Cited**

U.S. PATENT DOCUMENTS

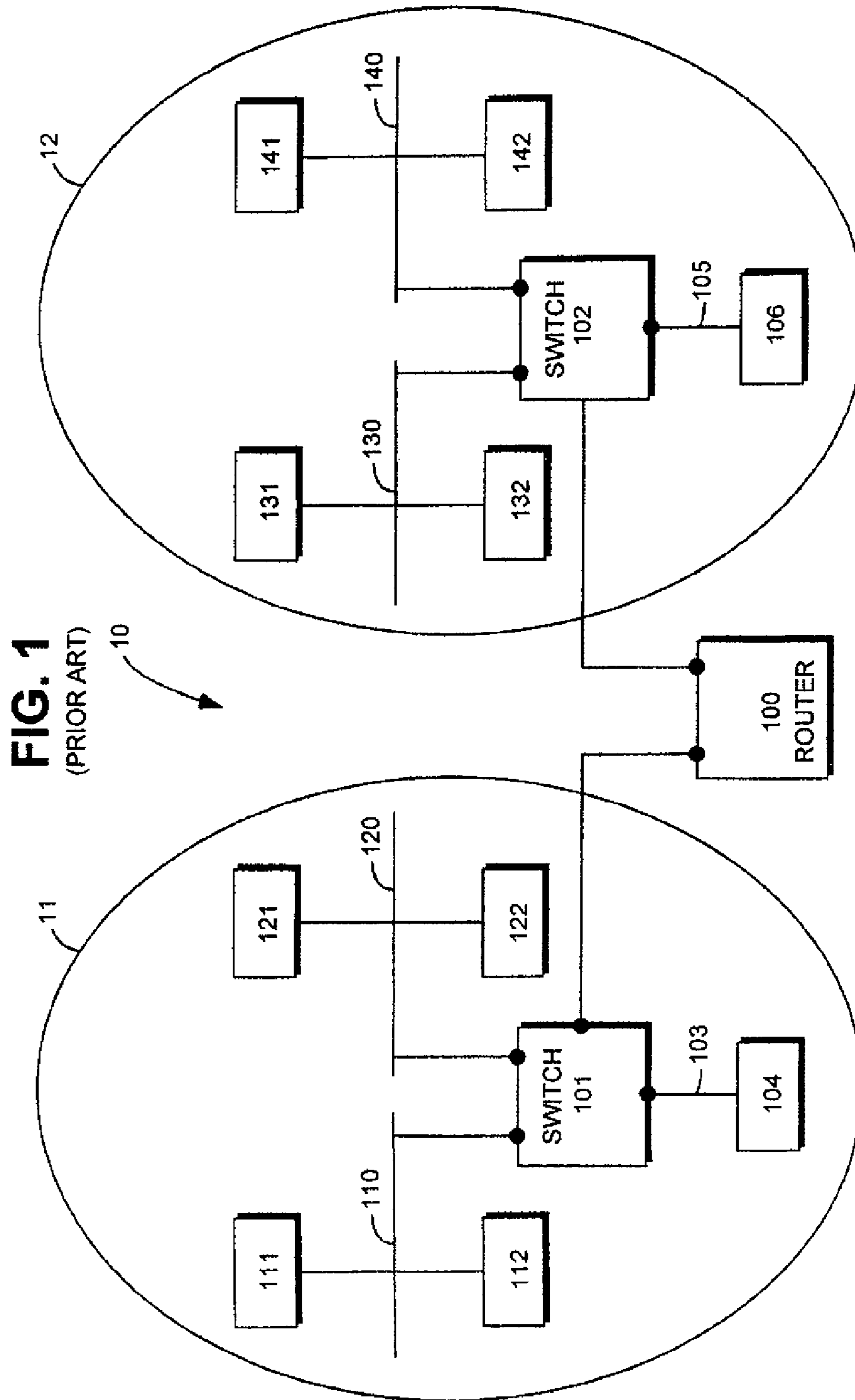
5,560,038 A 9/1996 Haddock  
 5,583,862 A 12/1996 Callon  
 5,617,421 A 4/1997 Chin et al.  
 5,684,800 A 11/1997 Dobbins et al. .... 370/401  
 5,740,171 A 4/1998 Mazzola et al. .... 370/392

5,742,604 A 4/1998 Edsall et al. .... 370/401  
 5,764,636 A 6/1998 Edsall .... 370/401  
 5,946,308 A 8/1999 Dobbins et al. .... 370/392  
 5,959,990 A \* 9/1999 Frantz et al. .... 370/392  
 6,111,876 A \* 8/2000 Frantz et al. .... 370/392  
 RE40,999 E \* 11/2009 Frantz et al. .... 370/395.3  
 8,023,515 B2 \* 9/2011 Dobbins et al. .... 370/395.53  
 RE44,775 E \* 2/2014 Frantz et al. .... 370/392  
 2009/0245227 A1 \* 10/2009 Chin et al. .... 370/350  
 2011/0134858 A1 \* 6/2011 Seo et al. .... 370/329

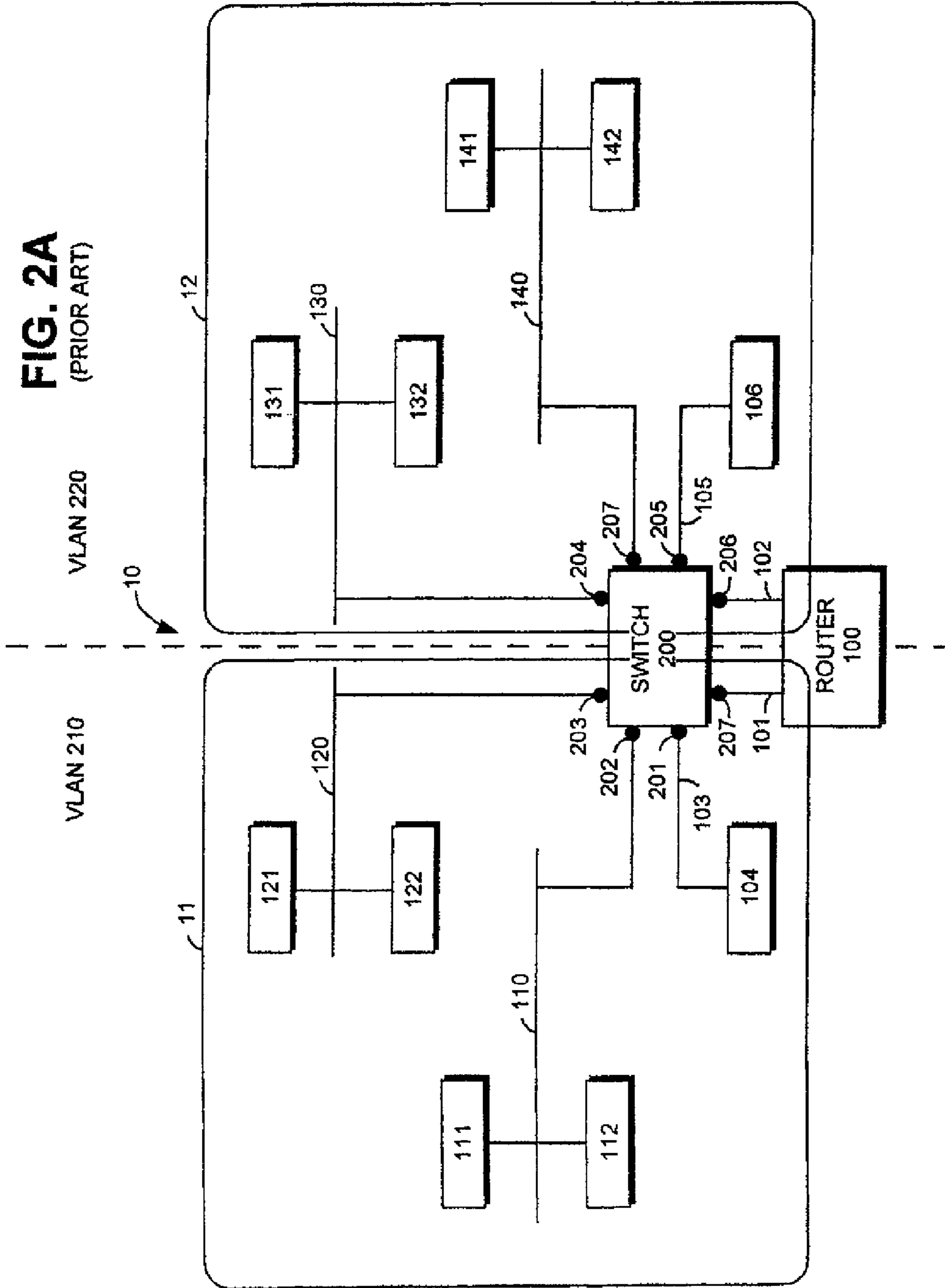
OTHER PUBLICATIONS

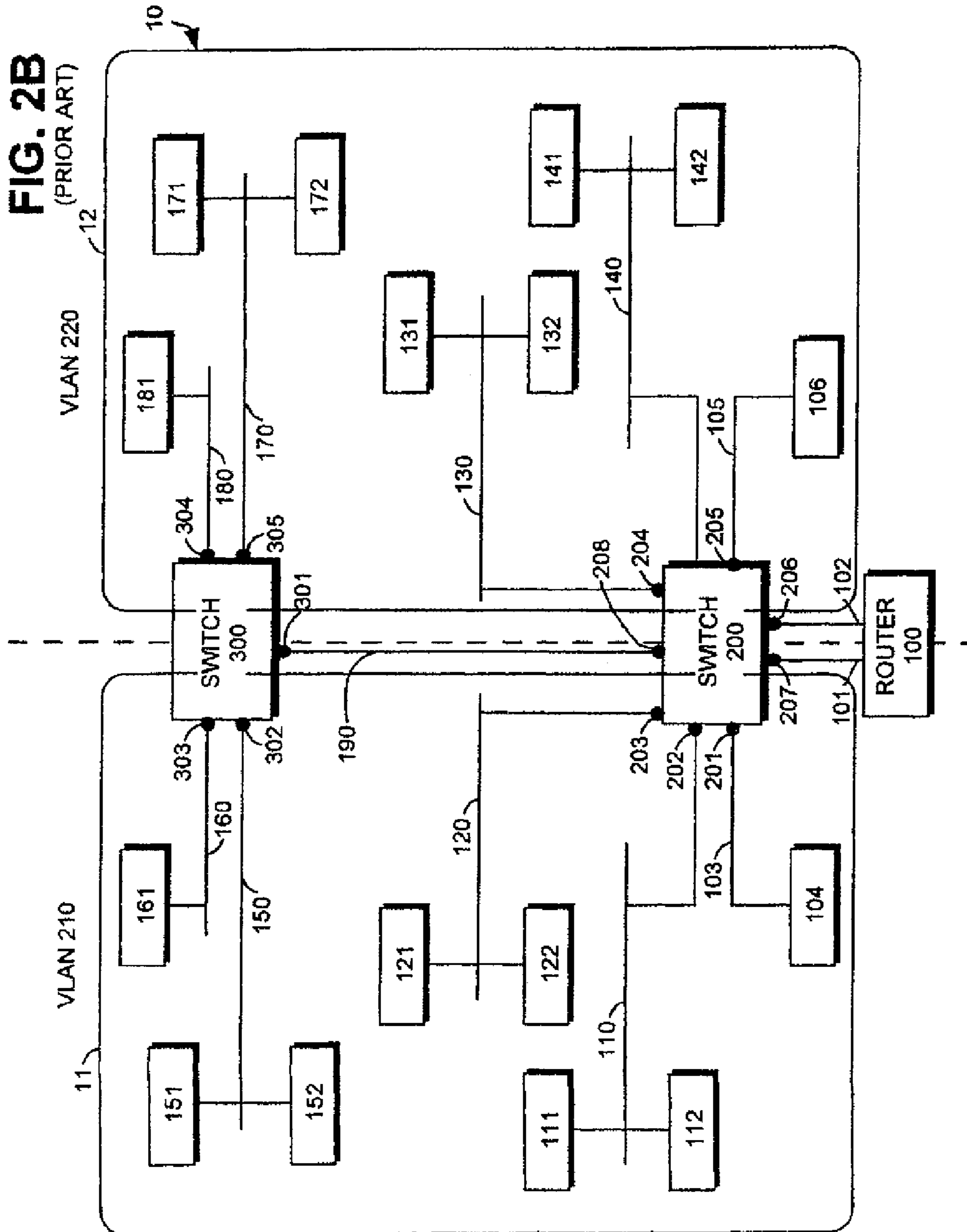
Local and Metropolitan Area Networks 802.10 Supplements, "IEEE Standards—Secure Data Exchange (SDE) Sublayer Management (Subclause 2.8) and Recommended Practice for SDE on Ethernet V2.0 in IEEE 802 LANs (Annex 2H)," May 19, 1994.  
 Local and Metropolitan Area Networks 802.10 Supplements, "Interoperable LAN/MAN Security (SILS)—Currently Contains Secure Data Exchange (SDE) (Clause 2)," Feb. 5, 1993.

\* cited by examiner

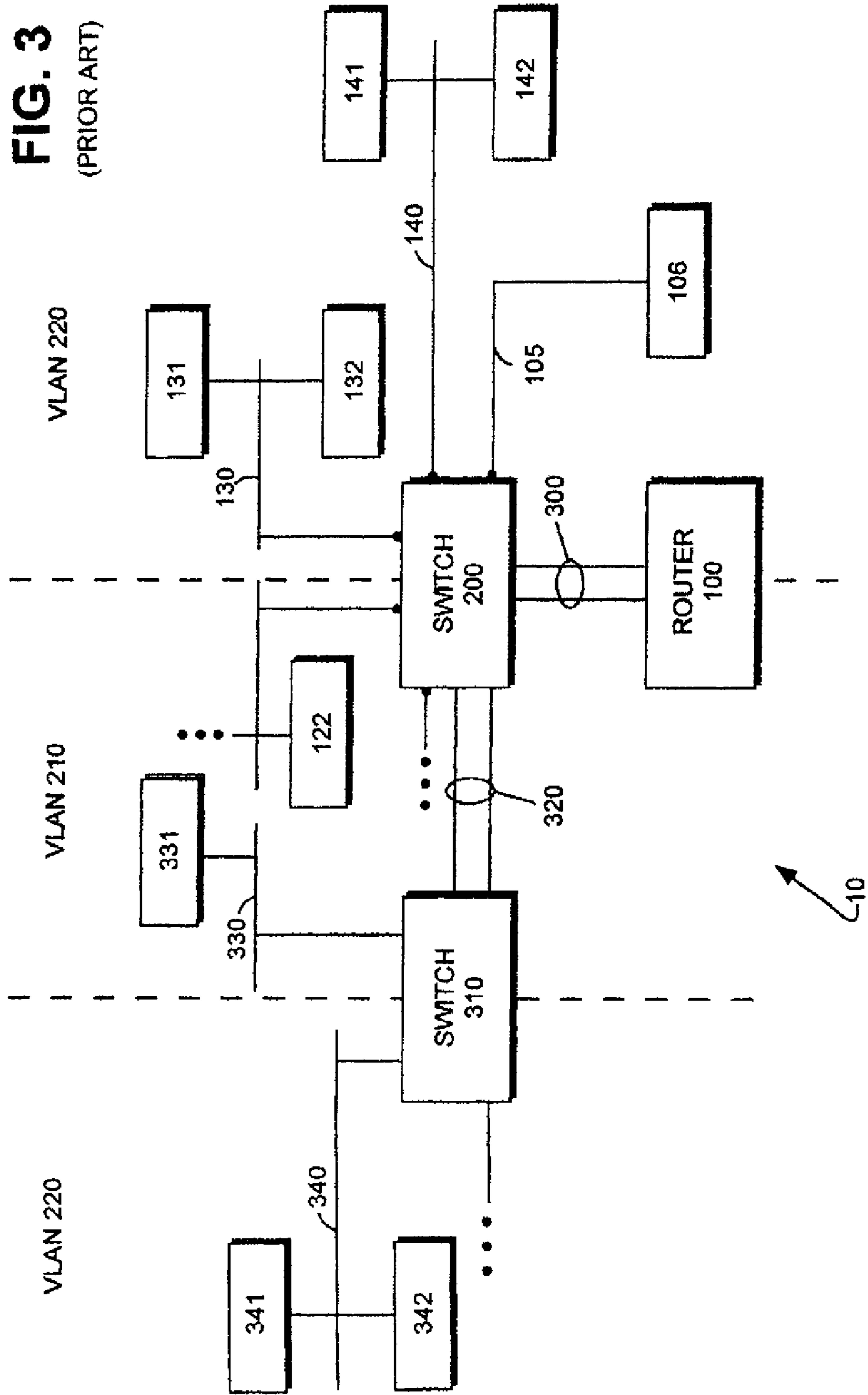


**FIG. 1**  
(PRIOR ART)





**FIG. 3**  
(PRIOR ART)



**FIG. 4**  
(PRIOR ART)

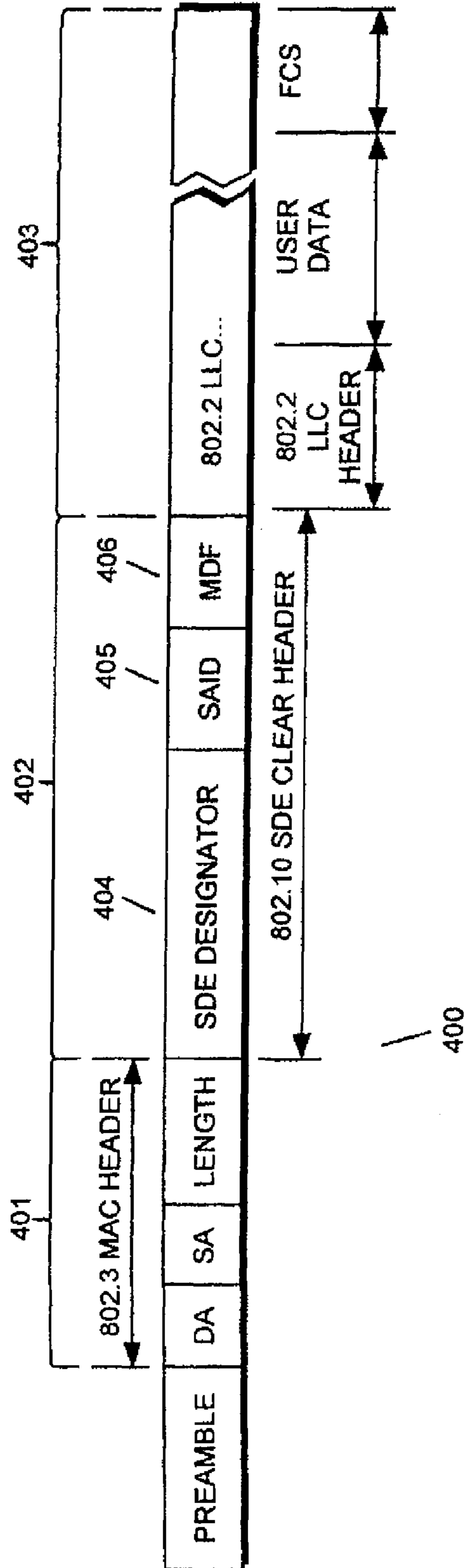


FIG. 5(A)

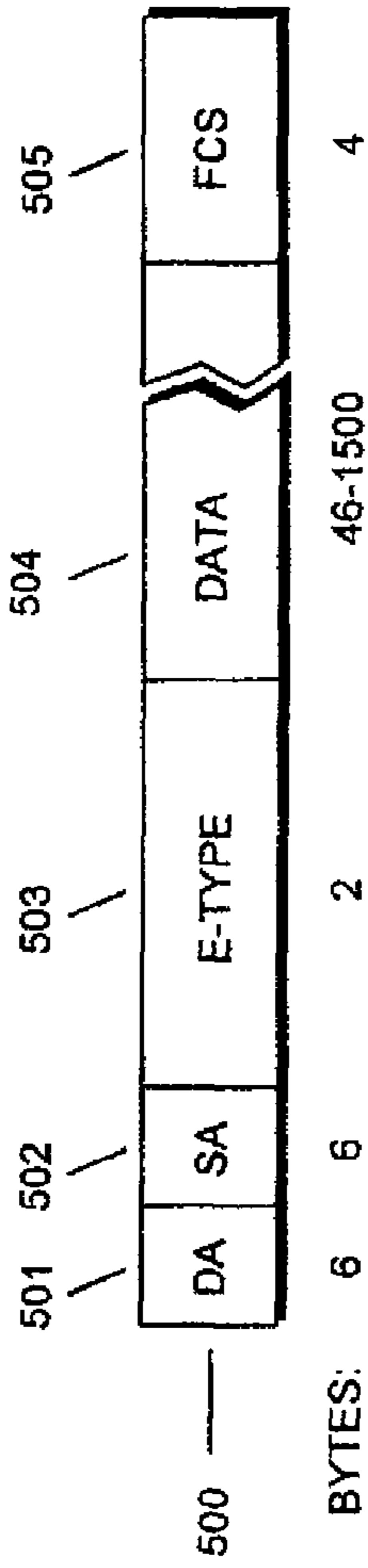


FIG. 5(B)

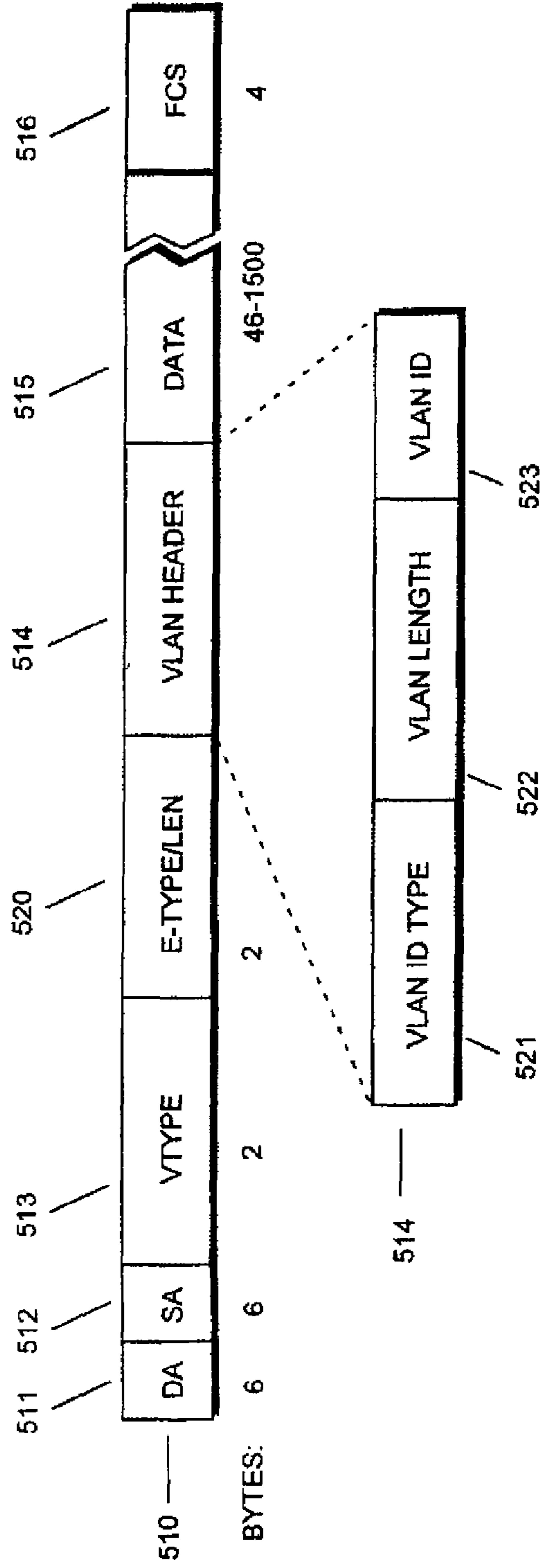
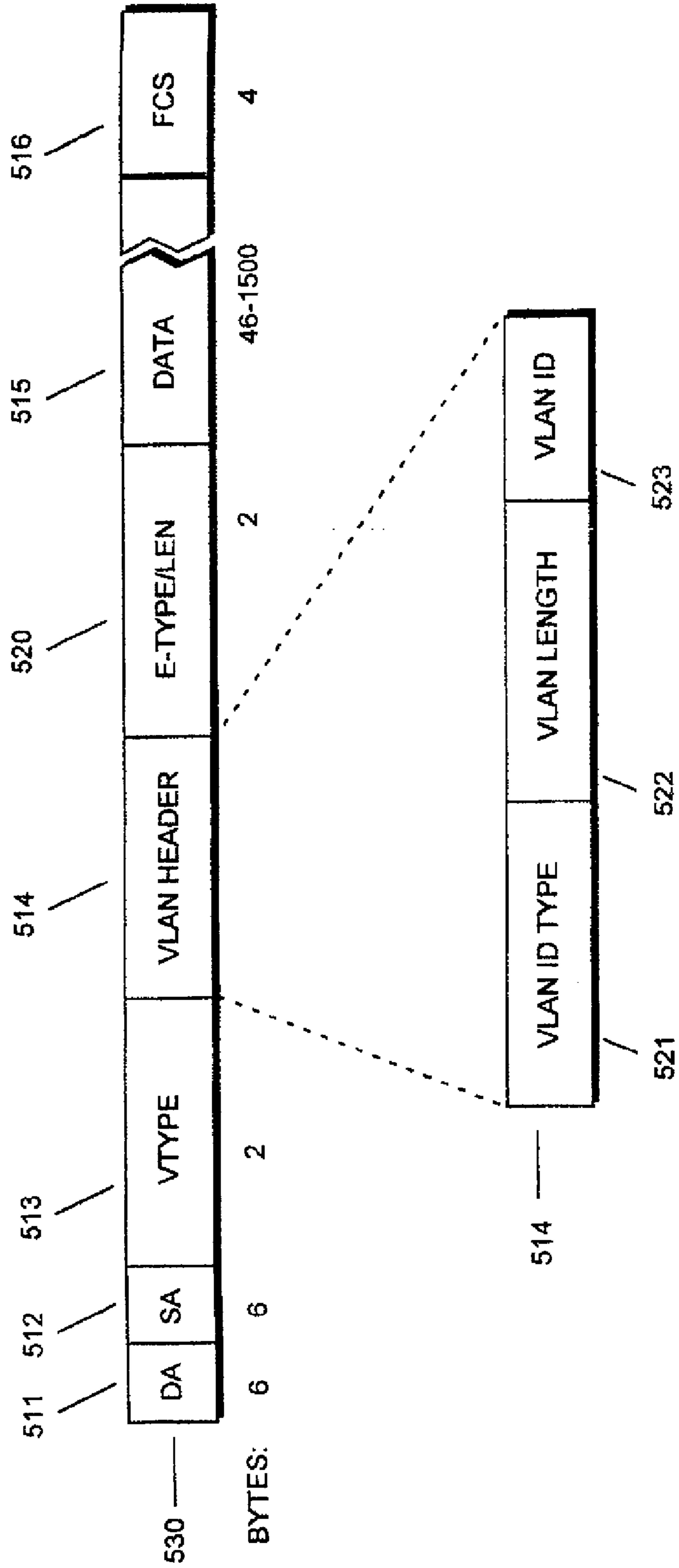




FIG. 5(C)



## VLAN FRAME FORMAT

**Matter enclosed in heavy brackets [ ] appears in the original patent but forms no part of this reissue specification; matter printed in italics indicates the additions made by reissue; a claim printed with strikethrough indicates that the claim was canceled, disclaimed, or held invalid by a prior post-patent action or proceeding.**

*NOTICE: More than one reissue application has been filed for the reissue of U.S. Pat. No. 6,111,876. The reissue applications are U.S. application Ser. No. 10/225,708, now Reissue U.S. Pat. No. Re. 40,999, issued on Nov. 24, 2009, and U.S. application Ser. No. 12/459,465, now Reissue U.S. Pat. No. Re. 44,775, issued on Feb. 25, 2014, which is a divisional reissue of U.S. application Ser. No. 10/225,708, now Reissue U.S. Pat. No. Re. 40,999. The present U.S. application Ser. No. 13/728,747, filed on Dec. 27, 2012, which has been filed during the pendency of U.S. application Ser. No. 12/459,465, now Reissue U.S. Pat. No. Re. 44,775, is a divisional reissue of U.S. application Ser. No. 12/459,465, now Reissue U.S. Pat. No. Re. 44,775, which is a divisional reissue of U.S. Pat. No. 6,111,876.*

*Other reissue applications include: U.S. application Ser. No. 13/728,770, filed Dec. 27, 2012, which is a continuation reissue of U.S. application Ser. No. 12/459,465, now Reissue U.S. Pat. No. Re. 44,775; U.S. application Ser. No. 13/728,787, filed Dec. 27, 2012, now Reissue U.S. Pat. No. Re. 45,065, issued on Aug. 5, 2014, which is a continuation reissue of U.S. application Ser. No. 12/459,465, now Reissue U.S. Pat. No. Re. 44,775; U.S. application Ser. No. 13/728,823, filed Dec. 27, 2012, now Reissue U.S. Pat. No. Re. 45,081, issued on Aug. 19, 2014, which is a continuation reissue of U.S. application Ser. No. 12/459,465, now Reissue U.S. Pat. No. Re. 44,775; U.S. application Ser. No. 13/728,838, filed Dec. 27, 2012, which is a continuation reissue of U.S. application Ser. No. 12/459,465, now Reissue U.S. Pat. No. Re. 44,775; U.S. application Ser. No. 13/728,846, filed Dec. 27, 2012, now Reissue U.S. Pat. No. Re. 45,095, issued on Aug. 26, 2014, which is a continuation reissue of U.S. application Ser. No. 12/459,465, now Reissue U.S. Pat. No. Re. 44,775; U.S. application Ser. No. 13/728,867, filed Dec. 27, 2012, which is a continuation reissue of U.S. application Ser. No. 12/459,465, now Reissue U.S. Pat. No. Re. 44,775; U.S. application Ser. No. 13/728,698, filed Dec. 27, 2012, which is a divisional reissue of U.S. application Ser. No. 12/459,465, now Reissue U.S. Pat. No. Re. 44,775.*

This application is a continuation-in-part of United States patent application entitled, "VLAN FRAME FORMAT", Ser. No. 08/613,726, filed on Mar. 12, 1996, now U.S. Pat. No. 5,959,990.

## COPYRIGHT NOTICE

Contained herein is material which is subject to copyright protection. The copyright owner has no objection to the facsimile reproduction of the patent disclosure by any person as it appears in the Patent and Trademark Office patent files or records, but otherwise reserves all rights to the copyright whatsoever.

## BACKGROUND OF THE INVENTION

## 1. Field of the Invention

The present invention relates to the field of data communications. More specifically, the present invention relates to a

method and frame format for preserving in a data frame the virtual local area network (VLAN) associated with the data frame as determined by a network device from which the data frame was received when transmitting the data frame over a communications medium shared among multiple VLANs. The method and frame format are equally applicable when the network device uses criteria in addition to or instead of the ingress port to associate a VLAN with the data frame.

## 2. Description of the Related Art

A small baseband local area network (LAN) typically connects a number of nodes, e.g., a server and workstations, to a shared communications medium wherein all nodes compete for available bandwidth on the shared communications medium. In an Ethernet or Institute of Electrical and Electronics Engineers (IEEE) 802.3 standard local area network, when a node transmits a unicast data frame on the network, every node coupled to the shared medium receives and processes the data frame to determine if it is the node to which the data frame is destined. Moreover, when a station transmits a broadcast data frame on the network, all nodes see the data frame and must process it to determine whether they should respond to the broadcasting node. As the number of nodes coupled to the medium increase, data traffic can become congested, resulting in an undesirable level of collisions and network related delays in transmitting data frames, which in turn results in network and node performance degradation.

A common prior art method of reducing congestion is to separate a LAN into multiple LAN segments by way of a network device, such as a bridge or network switch, operating at the Media Access Control (MAC) sublayer of the Data Link layer (layer 2) of the International Standards Organization (ISO) Open Systems Interconnection (OSI) reference model. While all nodes in the data network may still belong to the same broadcast domain, that is, each node still transmits and receives broadcast data frames to/from all nodes on all LAN segments in the network, nodes sharing the same LAN segment see only unicast data frames generated by or destined to a node on the same LAN segment. Given that the bulk of data traffic on a LAN is unicast in nature, segmentation may somewhat reduce collisions and traffic related performance problems.

However, as the number of LAN segments and nodes per segment increases in the same broadcast domain, the nodes can become overburdened processing broadcast data frames. It may be desirable under such circumstances to separate the growing data network into multiple broadcast domains. One possible approach to creating multiple broadcast domains is to separate one or more LAN segments using a network device such as a router, operating at the Network layer (layer 3) of the OSI reference model. With reference to FIG. 1, a data network 10 is illustrated wherein a number of internet-working devices are installed to reduce traffic levels on each LAN segment. A router 100 separates LAN segments 103, 110 and 120 into one broadcast domain 11, and LAN segments 105, 130 and 140 into another broadcast domain 12.

For example, router 100 only forwards a unicast data frame from a node on LAN segments 103, 110 or 120 that is specifically addressed (at layer 3 of the OSI model) to a node on LAN segments 105, 130 or 140, and vice versa. Network devices 101 and 102 may be, for example, network switches. Network switch 101 separates LAN segments 103, 110 and 120 to reduce unicast traffic on each segment while the segments still remain in the same broadcast domain 11. Network switch 102 functions in a similar manner with respect to LAN segments 105, 130 and 140.

LAN segments **110**, **120**, **130** and **140** may have multiple nodes attached. For example, LAN segment **110** has nodes **111** and **112** coupled to it, and functions, therefore, as a shared communications medium, wherein the nodes share the available bandwidth (e.g., 10 million bits per second in a traditional Ethernet carrier sense, multiple access data bus with collision detection [CSMA/CD]). LAN segments **103** and **105**, on the other hand, are dedicated LAN segments, therefore, nodes **104** and **106** have all available bandwidth to themselves. For example, nodes **104** and **106** may be servers requiring greater bandwidth. Dedicated LAN segments **103** and **105** may be any technology supporting delivery of Ethernet or IEEE 802 LLC data frames including CSMA/CD or Fiber Distributed Data Interface (FDDI) segments operating at 100 million bits per second, or Asynchronous Transfer Mode LAN emulation service running over segments operating at 155 million bits per second.

The router **100** has the further advantage of allowing for the implementation of policy restrictions among network administrator-defined groups in the network. For example, it may be desirable to prohibit nodes in broadcast domain **12** from communicating with nodes in broadcast domain **11** using any protocol except those specifically allowed by the network administrator.

However, as can be seen in FIG. 1, data network **10** involves significant hardware and software expenses associated with two network switches, a router, and the multiple communication lines required to achieve multiple broadcast domains. Moreover, a significant amount of administrative overhead is required to maintain the configuration and operation of the internetworking devices as required, for example, when a node is moved from one segment to another segment in the same or different broadcast domain. Thus, it is desirable to implement the data network **10** of FIG. 1 using a single network switch and virtual local area networks (VLANs).

FIG. 2A illustrates data network **10** using a single network switch **200** and virtual local area networks (VLANs) to create multiple broadcast domains **11** and **12**. A VLAN is a logical local area network comprised of a plurality of physical local area networks as determined by some network administrator-defined criteria, e.g., grouping local area networks based on geographical topology of the data network, or business units/functions of a company, such as finance or engineering departments. Such VLANs are generally configured based on the points where the physical LANs enter a switched network. For example, network switch **200** is configured such that ports **201** through **203** and **207** belong to VLAN **210**, and ports **204-206** belong to VLAN **220**. LAN segments **103**, **110** and **120** coupled to ports **201--203**, respectively, belong to VLAN **210**. LAN segments **130**, **140** and **105** coupled to ports **204**, **207**, and **205**, respectively, belong to VLAN **220**. The configuration of data network **10** in FIG. 2A is relatively less expensive than the configuration of data network **10** in FIG. 1 in that only one switch is required. Moreover, since VLANs are configured at network switch **200**, a network administrator can maintain configuration and operation of the network without concern for moving a node from one LAN segment to another LAN segment in the same VLAN.

When the system grows beyond the capacity of a single switch or when geographical constraints create a need for switching capacity at more than one site, additional switches are added to the network. FIG. 2B shows the addition of switch **300** to the network shown in FIG. 2A. LAN segment **190** is used to link switch **300** to switch **200**. Switch **300** supports segments **150** and **160** in VLAN **210** and segments **170** and **180** in VLAN **220**.

In the prior art, when switch **200** receives a broadcast packet from VLAN **210**, station **104**, it forwards the packet out all of its other VLAN **210** ports (**202**, **203** and **207**) and also forwards it from port **208** to switch **300**. Switch **300** examines the MAC source address (i.e., the ISO layer 2 source address) and based on a prior exchange of information with switch **200** is able to determine the proper VLAN to use for frames from that source address, in this case, VLAN **210**. Based on this determination, switch **300** forwards the frame to all of its VLAN **210** ports (e.g., ports **302** and **303**).

The success of this approach depends on prohibiting frames having the same MAC source address from appearing on multiple VLANs. However, the prohibition makes this approach unusable in some networks. To work around this problem, some prior art implementations use additional fields within the packet, such as the ISO layer 3 source address, to resolve ambiguities. However, even this approach does not work in all cases, as there are many types of frames which do not contain sufficient information to make a reliable VLAN determination. Examples of such frames include Internet Protocol (IP) BOOTP requests, IPX Get Nearest Server requests and frames from non-routable protocols.

All messages (in the form of a data frame) transferred between nodes of the same VLAN are transmitted at the MAC sublayer of the Data Link layer of the OSI reference model, based on each node's MAC layer address. However, there is no connectivity between nodes of different VLANs within network switch **200** or **300**.

For example, with reference to FIG. 2A, even though all physical LAN segments **103**, **105**, **120**, **130**, and **140** are connected to ports on network switch **200**, the VLAN configuration of switch **200** is such that nodes in one VLAN cannot communicate with nodes in the other VLAN via network switch **200**. For example, node **104** can communicate with node **122** but cannot communicate with node **142** by way of switch **200**. Rather, router **100** connects VLAN **210** to VLAN **220** via communications mediums **101** and **102** respectively, so that node **104** can communicate with node **142**. Messages transferred between nodes of different VLANs are most often transmitted at the Network layer of the OSI reference model, based on the Network layer address of each node, e.g., an Internet Protocol (IP) address. Router **100** also allows a network administrator to configure appropriate policy restrictions and security rules to reduce unnecessary or unwanted traffic in data network **10**.

Using a routing function to transfer data frames between VLAN **210** and VLAN **220** as illustrated in FIG. 2B is inappropriate, however, for data frames of protocol suites that do not support a network layer protocol, e.g., DEC LAT or NetBIOS. To deal with this problem, routers commonly provide a capability for bridging frames of non-routable protocols. For example, assume node **106** in VLAN **220** uses the DEC LAT protocol in an attempt to transmit a data frame to a node in VLAN **210**. Switch **200** receives the data frame from node **106** over dedicated communications medium **105** and transfers it to router **100** via communications medium **102**. Router **100**, not being able to route DEC LAT traffic, may bridge the data frame back to switch **200** via communications medium **101**. Switch **200** receives the data frame and, because the data frame is bridged instead of routed, the source MAC address is unchanged. Switch **200** has now received on both ports **205** (in VLAN **220**) and **207** (in VLAN **210**) a data frame having the MAC address for node **106**, and cannot, therefore, unambiguously determine over which port node **106** is connected, or which VLAN should be associated with node **106**. There-

fore, switch **200** is unable to inform switch **300** of which VLAN should be associated with the MAC address of node **106**.

Another circumstance which creates difficulties in establishing a MAC address to VLAN mapping is when a routing protocol, e.g., the DecNet routing protocol, transmits data frames using the same source MAC address on both communications mediums **101** and **102**.

Yet another drawback of the configuration of data network **10** as illustrated in FIG. 2A is that a communications link is needed between network switch **200** and router **100** for each virtual local area network (VLAN). As the number of physical LAN segments and VLAN segments increase, and as the distance between LANs increase necessitating utilization of metropolitan- and wide-area communications mediums/facilities, the monetary and administrative expense required to maintain data network **10** also increases. As illustrated in FIG. 3, one means of reducing this expense is to combine multiple communications links into a single shared communications medium **300** between switch **200** and router **100**. The same problems which prevented switch **300** in FIG. 2B from reliably determining the proper VLAN for frames received over segment **190** also prevent switch **200** in FIG. 3 from reliably associating VLANs with data frames received over segment **300**. Thus, a means is needed to identify the virtual local area network (VLAN) from which a frame originated when transferring the frame over a communications medium shared among multiple VLANs.

One such prior art method identifying the VLAN associated with a MAC address of a node involves creating and maintaining a lookup table on each network device in the data network. The lookup table contains entries associating the MAC address of a node with the port on the network device over which the node is reachable. The node may be coupled to a shared or dedicated communications medium which is further coupled to the port. Each entry also contains a VLAN identifier identifying the virtual local area network (VLAN) assigned to the port. If multiple network devices exist in the data network, as illustrated in FIG. 3, they may utilize a protocol to exchange lookup tables so that each device knows which VLAN is assigned to each port on each device and what nodes (identified by their respective MAC addresses) are reachable via each port as well as which nodes belong to the same VLAN and are allowed, therefore, to communicate with each other.

A prior art method of reliably identifying the VLAN from which a data frame originated utilizes a management defined field (MDF) of an IEEE standard 802.10 Secure Data Exchange (SDE) Protocol Data Unit (PDU). The MDF allows the transfer of proprietary information that may facilitate the processing of a data frame. The prior art method uses the MDF to store a VLAN identifier as the data frame is transferred from a network device over a communications medium shared among multiple VLANs so that when another network device receives a data frame from the shared communications medium, it can determine the VLAN associated with the data frame and determine whether to forward the frame accordingly, depending on the VLANs configured for each port on the network device.

FIG. 4 illustrates the frame format for an IEEE 802.3 MAC/802.10 SDE data frame utilizing the MDF to identify the VLAN associated with the data frame. Portion **401** of data frame **400** is the IEEE 802.3 media access control (MAC) header, comprising a 6 byte destination MAC address field, and 6 byte source MAC address field, and a 2 byte length field. Portion **402** indicates the IEEE 802.10 secure data exchange (SDE) clear header, comprising the SDE designator field **404**

containing a special destination service access point (DSAP), source service access point (SSAP), and control field for SDE frames, a security association identifier (SAID) field **405**, and the management defined field (MDF) **406**. The remainder of the original data frame, comprising its IEEE 802.2 LLC header followed by the user data, is included in field **403**.

A VLAN identifier representing the VLAN associated with the data frame received by the network device is placed in the MDF **406** by the MAC layer and other relevant hardware and software in the network device. When the frame is subsequently transmitted across a shared communications medium, such as when switch **300** of FIG. 2B forwards over shared communications medium **190** a data frame destined for a node coupled to a port associated with a different VLAN on switch **200**, switch **200** is able to determine the VLAN from which the data frame was received by switch **300** and forward it accordingly to router **100** (if, indeed, inter-VLAN communication is required). Router **100** then routes the data frame back to switch **200**, where switch **200** then determines whether to forward the frame to the appropriate port based on the VLAN identifier in the MDF and destination MAC address in the destination MAC address field.

However, the frame format illustrated in FIG. 4 supports only the IEEE 802.3 media access control standards. An Ethernet-based data frame is considered nonstandard by the IEEE, and, therefore, cannot utilize the IEEE 802.10 header, or any other IEEE based header to preserve the VLAN, except through the use of an additional layer of encapsulation. IEEE Recommended Practice 802.1H is one way of performing this additional encapsulation. This extra layer of encapsulation reduces the efficiency of bandwidth utilization and adds complexity to the implementation. Thus, a method and frame format for identifying the VLAN associated with a data frame received at a network switch from either an Ethernet LAN or an IEEE 802.3 LAN is needed to support the existing infrastructure of Ethernet networks in a data network transmitting data frames from multiple VLANs across a shared communications medium. This will allow compatibility with Ethernet-based nodes on the same shared media with nodes supporting VLAN identification.

#### SUMMARY OF THE DISCLOSURE

The present invention relates to a method and frame format for preserving in a data frame as the data frame is transmitted across a communications medium shared among a plurality of virtual local area networks (VLANs), the VLAN which was associated with the data frame at the point where it entered the network. The method supports existing data network infrastructures, including Ethernet based data network infrastructures.

According to one aspect of the invention, a data frame format extends the traditional Ethernet frame format to accommodate a VLAN header. In one embodiment, a unique Ethernet type field value is used to identify the data frame as having a VLAN header inserted between the Ethernet type field and the user data field. In another embodiment, the unique Ethernet type field value is used to identify the data frame as having a VLAN header inserted prior to the Ethernet type field of the original Ethernet frame.

The original Ethernet type field or the length field of an IEEE 802.3 data frame is preserved when the data frame is transferred from a shared communications medium to a dedicated communications medium, as when happens when a network switch receives the data frame over shared communications medium coupling the network switch to another

network switch, and transmits the data frame over a dedicated communications medium coupling the network switch to a node.

The VLAN header comprises a VLAN identifier field that identifies the VLAN associated with the frame at the point at which the data frame was received by a network switch. In one embodiment, the VLAN header is further comprised of a VLAN identifier type and/or a VLAN identifier length field, both of which precede the VLAN identifier field and respectively specify a format and length of the subsequent VLAN identifier field.

Thus it is an object of the present invention to provide a method and frame format for identifying the VLAN associated with a data frame received at a network switch from an Ethernet or IEEE 802.3 LAN. This is needed to support the existing infrastructure of Ethernet networks in a data network transmitting data frames from multiple VLANs across a shared communications medium. This will allow compatibility with both IEEE 802.3-based and traditional Ethernet-based nodes on the same shared media with nodes supporting VLAN identification as well.

It is another object of the present invention to provide a data frame format that allows for inclusion of a VLAN identifier field that does not extend the MAC frame so far as to require fragmentation to avoid ambiguity between Ethernet and IEEE 802.3 frame types.

#### BRIEF DESCRIPTION OF THE DRAWINGS

The present invention is illustrated by way of example and not limitation in the following figures. Like references indicate similar elements, in which:

FIG. 1 illustrates a prior art data network topology.

FIG. 2A illustrates a prior art data network topology utilizing virtual local area networks.

FIG. 2B illustrates a prior art data network topology utilizing virtual local area networks and shared communications media between network devices.

FIG. 3 further illustrates a prior art data network topology utilizing virtual local area networks and shared communications media between network devices.

FIG. 4 illustrates the IEEE 802.3 MAC/802.1 SDE frame format as may be utilized in the prior art.

FIG. 5(a) illustrates an Ethernet frame format.

FIG. 5(b) illustrates a modified Ethernet frame format as may be utilized by the present invention.

FIG. 5(c) illustrates a modified Ethernet frame format as may be utilized by the present invention.

#### DETAILED DESCRIPTION OF THE EMBODIMENTS OF THE INVENTION

Described herein is a method and frame format for preserving in a data frame the virtual local area network (VLAN) associated with the data frame when transmitting the data frame over a communications medium shared among multiple VLANs. In the following description, numerous specific details are set forth in order to provide a thorough understanding of the present invention. It will be apparent, however, to one of ordinary skill in the art that the present invention may be practiced without these specific details. In other instances, well-known standards, frame format details, and techniques have not been shown in order not to unnecessarily obscure the present invention.

As network switching becomes more prevalent in data networks, and in particular, local area networks, it is desirable to segment data traffic into groups of virtual local area net-

works (VLANs), as discussed above. Generally, the MAC address of each node, as determined by the contents of the source MAC address field of a data frame transmitted by the node, is mapped to, or associated with, a VLAN assigned to the port of a network device (e.g., a network switch) at which the data frame enters the switched network. The method by which the network device forwards the data frame varies depending on whether the target node (as determined by the MAC address in the destination MAC address field of the data frame) resides on the same or different VLAN as the source node. It may be desirable to use a standard shared communications medium such as IEEE standard 10BASE-F or 100BASE-T for a backbone transmission fabric between network devices in a switched network. However, unless separate cables are used for each VLAN, the VLAN association of each data frame cannot be determined when the data frame is transmitted over the shared communications medium. A means for identifying, or preserving, the VLAN associated with each data frame when transmitting the data frames over a shared communications medium is needed.

The method described herein provides for a shared communications medium for transferring data frames from multiple virtual local area networks (VLANs) while preserving the VLAN associated with each frame, regardless of whether the data network supports the interconnection of Ethernet or IEEE standard 802.3 nodes.

FIG. 5(a) illustrates the data frame format for an Ethernet network. Like the IEEE standard 802.3 frame format, the Ethernet frame format begins with a 6 byte destination MAC address field followed by a 6 byte source MAC address field. However, unlike the IEEE standard 802.3 frame format, a 2 byte Ethernet type (ETYPE) field **503** follows the source MAC address field. The ETYPE field indicates the protocol type of the next upper layer protocol header which begins immediately following the ETYPE field (e.g., 0800(h) indicates the IP network layer protocol). The data field **504** comprises any upper layer protocol information and user data, all of which is considered data from the perspective of the MAC sublayer. Finally, a frame check sequence (FCS) field **505**, comprising a 32-bit cyclical redundancy check (CRC) of the contents of fields **501**, **502**, **503** and **504**, completes the data frame.

An IEEE 802.3 frame format also begins with a 6 byte destination MAC address field followed by a 6 byte source MAC address field. As is well known to those of skill in the art, a 2 byte LENGTH field follows the source MAC address field. It should be noted that the present invention, although based on a modification of the Ethernet frame format described above, applies equally well when the original frame is an IEEE 802-standard format (e.g., IEEE 802.3). In such a case, the field following the MAC source address contains not the protocol type of an upper layer protocol, but a value indicating the length of the data field, as discussed above. The present invention preserves the value in that field in a new extended Ethernet frame format, but makes no other use of it, and is, therefore, not sensitive to whether the field contains protocol type or length information.

FIG. 5(b) illustrates a data frame format that may be utilized by one embodiment of the present invention. The frame format extends the Ethernet frame format illustrated in FIG. 5(a) to accommodate a virtual local area network (VLAN) header **514**, along with its associated VTYPE field **513**. FIG. 5(b) illustrates a virtual type (VTYPE) field **513**. VTYPE field **513** is inserted after the source MAC address field **512** and before the ETYPE field **520** of an Ethernet data frame or the length field of an IEEE 802.3 data frame. The virtual type (VTYPE) field **513** identifies the remainder of the frame as an

extended Ethernet frame comprising a VLAN header **514** inserted, for example, after the Ethernet type field **520** and before the data field **515** shown in FIG. **5(b)**.

The contents of the ETYPE field **503** in FIG. **5(a)**, or the length field of an IEEE 802.3-based data frame is retained. Location **503** in FIG. **5(a)** becomes location **520** in FIG. **5(b)**. The ETYPE field at location **520** returns back to location **503** in FIG. **5(a)** when the data frame is transferred from a shared communications medium used to transmit data frames for multiple VLANs to a dedicated communications medium used to transmit data frames for a single VLAN.

A VLAN identifier type (VLAN ID TYPE) field and VLAN identifier length (VLAN LEN) field are present at locations **521** and **522**, respectively. These two fields are used in combination to specify the format of the VLAN identifier (VLAN ID) field **523**. Although this embodiment of the present invention utilizes only one type and length of VLAN ID field, it is foreseeable that multiple types of VLAN identifiers may be utilized, and that such identifiers may be of varying lengths, depending on the information conveyed by such identifiers, in which case, a network device receiving the data frame should check the VLAN ID TYPE and VLAN LEN fields and determine whether to accept or reject the data frame. In the event multiple VLAN ID TYPES are utilized, it is envisioned that the VLAN ID TYPE values will be dispensed by an administrative authority.

The VLAN identifier length (VLAN LEN) field specifies the length of the VLAN identifier field in bytes. In this embodiment, the VLAN identifier field is 4 bytes in length. It is envisioned that the length of the VLAN identifier field will be a multiple of 4 bytes to maintain word alignment of fields in the data frame.

The VLAN identifier (VLAN ID) field **523** identifies the VLAN associated with the data frame. A network administrator or similar network wide authority is required to dispense values on a dynamic basis when configuring the virtual networks of the data network.

A new FCS **516** is calculated and replaces the prior FCS **505**. FCS **516** performs a CRC on the destination and source MAC address fields, VTYPE field, ETYPE field, VLAN header, and data field.

While one embodiment has been described wherein the VLAN header **514** comprises the VLAN ID TYPE field, the VLAN identifier length (VLAN LEN) field, and the VLAN identifier (VLAN ID) field, alternative embodiments do not necessarily utilize such a VLAN header. For example, in one embodiment, the ETYPE field **503** in FIG. **5(a)**, or the length field of an IEEE 802.3-based data frame is contained in the VLAN header. In other words, the VLAN header **514** includes the location **520** wherein the value in the ETYPE field **503** in FIG. **5(a)**, or the length field of an IEEE 802.3-based data frame is preserved. In other embodiments, the VLAN header does not contain one or both of the VLAN ID TYPE field and the VLAN identifier length (VLAN LEN) field. Thus, the VLAN header can contain any number of fields in addition to the VLAN identifier (VLAN ID) field. It is appreciated that the format of the VLAN header can be differentiated by assignment of differing values to VTYPE field **513**.

The extended Ethernet frame format illustrated in FIG. **5(b)** may be utilized in the following manner. A network device (e.g., a network switch) has been configured so that a virtual local area network identifier representing a virtual local area network is assigned to each port on the network device. A data frame utilizing the Ethernet frame format (see FIG. **5(a)**) or IEEE 802.3-based frame format may be transmitted by a node over a dedicated communications medium to

the network switch. The network switch receives the data frame at a port coupled to the dedicated communications medium. At that time, or prior to transmitting the data frame over a shared communications medium to another network device, the network switch inserts a VTYPE field **513** between the source MAC address field **512** and the ETYPE field or length field **520** (depending on the frame format). The network switch then inserts a VLAN header between the ETYPE field or length field and data field of the data frame. The value originally in the ETYPE field **503** (or length field in the case of an IEEE 802.3-based frame format) of FIG. **5(a)** is retained in ETYPE/Length field **520** as shown in FIG. **5(b)**. A value is placed in the VTYPE field **513** identifying the frame as containing VLAN identifier information (VTYPE **513**). If utilized, a VLAN identifier type and VLAN identifier length field is inserted in VLAN header **514** at **521** and **522**. Finally, the VLAN identifier associated with the data frame is placed in the VLAN identifier field **523**. The data frame now having an extended Ethernet frame format is then transmitted over a shared communications medium.

Upon receiving the data frame, a network device processes the data frame. It determines the MAC address of a target node based on the contents of the destination MAC address field **511**. Following the source MAC address field **512**, the device then detects the presence of a VLAN header based on the contents of the VTYPE field, and determines the VLAN identifier associated with the data frame based on the contents of the VLAN identifier field. If a port on the network device which is eligible to receive the frame based on the destination MAC address is assigned the same VLAN identifier as the data frame, the network device then removes the VTYPE field and VLAN header from the data frame, calculates a new FCS for the data frame, and transmits the data frame out the port over a dedicated communications medium to the target node.

FIG. **5(c)** illustrates a data frame format that may be utilized by an alternative embodiment of the present invention. The frame format also extends the Ethernet frame format illustrated in FIG. **5(a)** or an IEEE 802.3-based frame format, as did the frame format in FIG. **5(b)**, to accommodate a virtual local area network (VLAN) header **514**. A virtual type (VTYPE) field **513** and VLAN header **514** is inserted between the source MAC address field **512** and ETYPE field **520** of an Ethernet data frame (or the length field of IEEE 802.3-based data frame) to respectively identify the frame as an extended Ethernet frame, and provide the VLAN identifier. Unlike the embodiment described in reference to FIG. **5(b)** wherein the ETYPE/Length field **520** follows the VTYPE field **513** and precedes the VLAN header **514** in the data frame, the VLAN header **514** is inserted between the VTYPE field **513** and the ETYPE/Length field **520** such that the ETYPE field **520** follows the VTYPE field **513** and VLAN header **514**.

The extended Ethernet frame format illustrated in FIG. **5(c)** may be utilized in a similar manner as the previously described embodiments of the invention. For example, when a network switch receives the data frame at a port coupled to the dedicated communications medium, at that time, or prior to transmitting the data frame over a shared communications medium to another network device, the network switch inserts, at a location following the source address field **512**, the VTYPE field **513**. A value in the VTYPE **513** indicates the presence of a VLAN header. The network switch also inserts the VLAN header **514** following the VTYPE field **513**. The data frame, now having an extended Ethernet frame format, can be transmitted over a shared communications medium.

Upon receiving the data frame, a network device processes the data frame. It determines the MAC address of a target

## 11

node based on the contents of the destination MAC address field **511**, and the MAC address of a source node based on the contents of the source MAC address field **512**. The device then processes the VTYPE field **513**. In processing the VTYPE field **513**, the device detects the presence of the VLAN header **514**, and determines the format of the VLAN identifier (VLAN ID) field **523** associated with the data frame from the VLAN identifier type (VLAN ID TYPE) field **521** and the VLAN identifier length (VLAN LEN) field **522**. Subsequent to processing the VLAN header **514**, the network device continues processing the data frame as it would process a non-VLAN frame.

While one embodiment has been described wherein a VLAN identifier type field is followed by a VLAN length field in the VLAN header, alternative embodiments of the invention do not necessarily use one or both of these fields, or may specify a VLAN length field followed by a VLAN identifier type field in a VLAN header. Thus, it is appreciated that the embodiment illustrated in FIG. **5(c)** can be modified in any number of ways, as long as a VTYPE field is followed, in order, by a VLAN identifier field and an Ethernet type field (or length field for IEEE 802.3-based data frames).

There are, of course, other alternatives to the described embodiments of the invention which are within the understanding of one of ordinary skill in the relevant art. For example, the type of network switch which has a single VLAN identifier associated with each port and assumes that a data frame received on a port is destined for the VLAN associated with that port is just one type of network switch. Network switches may present more sophisticated methods of handling VLANs. In the general case, when a data frame is received from an end station on a network switch port, the switch will apply a set of rules to determine the VLAN to which that data frame should be forwarded. The rules can include such things as the port number at which a data frame is received, the data frame's ISO Layer **3** protocol type, the data frame's MAC or network layer source address, time of day, etc. More importantly, the first VLAN aware network switch to receive the data frame should apply its rules and assign the data frame to a VLAN. Thus, the present invention is intended to be limited only by the claims presented below.

Thus, what has been described is a method and frame format for preserving in a data frame the virtual local area network (VLAN) associated with a port on a network device from which the data frame was received when transmitting the data frame over a shared communications medium.

We claim:

**[1.** A method of identifying a virtual network associated with a data frame when transmitting said data frame between a communications medium and a shared communications medium, comprising the steps of:

- a) receiving said data frame from said communications medium, said data frame comprising a first type field and a data field;
- b) inserting a second type field at a location within said data frame preceding said first type field, said second type field indicating said data frame comprises a virtual network identifier field;
- c) inserting said virtual network identifier field at a location between said second type field and said first type field;
- d) assigning a first value to said virtual network identifier field, said first value corresponding to said virtual network; and
- e) transmitting said data frame over said shared communications medium.]

## 12

**[2.** The method of claim **1**, further comprising the steps of:  
1) inserting between said second type field and said virtual network identifier field a virtual network identifier type field; and

2) assigning a second value to said virtual network identifier type field indicating a type of said first value in said virtual network identifier field.]

**[3.** The method of claim **1**, further comprising the steps of:  
1) inserting between said second type field and said virtual network identifier field a virtual network identifier length field; and

2) assigning a second value to said virtual network identifier length field indicating a length of said first value in said virtual network identifier field.]

**[4.** The method of claim **1** wherein said virtual network identifier field is 4 bytes.]

**[5.** The method of claim **1** wherein said virtual network identifier field is a multiple of 4 bytes.]

**[6.** The method of claim **1** wherein said first type field indicates a protocol type.]

**[7.** A method of identifying a virtual network associated with a data frame when transmitting said data frame between a communications medium and a shared communications medium, comprising the steps of:

a) receiving said data frame from said communications medium, said data frame comprising a length field and a data field;

b) inserting a type field at a location within said data frame preceding said length field, said type field indicating said data frame comprises a virtual network identifier field;

c) inserting said virtual network identifier field at a location between said type field and said length field;

d) assigning a first value to said virtual network identifier field, said first value corresponding to said virtual network; and

e) transmitting said data frame over said shared communications medium.]

**[8.** The method of claim **7**, further comprising the steps of:  
1) inserting between said type field and said virtual network identifier field a virtual network identifier type field; and

2) assigning a second value to said virtual network identifier type field indicating a type of said first value in said virtual network identifier field.]

**[9.** The method of claim **7**, further comprising the steps of:  
1) inserting between said type field and said virtual network identifier field a virtual network identifier length field; and

2) assigning a second value to said virtual network identifier length field indicating a length of said first value in said virtual network identifier field.]

**[10.** The method of claim **8** wherein said virtual network identifier field is a multiple of 4 bytes.]

**[11.** In a network device, a method of transmitting a virtual network identifier in a data frame transmitted on a shared communications medium coupled to said network device, comprising:

a) transmitting a preamble field;

b) transmitting a destination and source media access control address field;

c) transmitting a first type field whose contents indicate said virtual network identifier is present in said data frame;

d) transmitting a virtual network identifier field containing said virtual network identifier;

e) transmitting a second type field whose contents indicate a protocol type associated with said data frame; and,

f) transmitting a data field.]

## 13

**[12.** The method of claim 11 wherein said virtual network identifier field is 4 bytes.]

**[13.** In a network device having a first port coupled to a local area network (LAN) segment and a second port coupled to a shared communications medium, a method of associating a virtual network with a data frame received from said LAN segment and transmitted to said shared communications medium, comprising:

- a) receiving said data frame at said first port, said data frame comprising a type field and a data field;
- b) replacing a first value in said type field representing a protocol type with a second value indicating said data frame comprises a virtual network identifier field;
- c) inserting said virtual network identifier field in said data frame between said type field containing said second value and said data field;
- d) assigning a value representing said virtual network to said virtual network identifier field; and
- e) transmitting said data frame from said second port.]

**[14.** The method of claim 13 further comprising:

- a) inserting a new type field between said virtual network identifier field and said data field; and
- b) assigning said first value representing said protocol type to said new type field to preserve said protocol type.]

**[15.** The method of claim 13 wherein said virtual network identifier field is 4 bytes.]

**[16.** The method of claim 13 wherein said virtual network as identifier field is a multiple of 4 bytes.]

17. A network device comprising:

a first port configured to be coupled to a local area network (LAN);

a second port configured to be coupled to a shared communications medium;

a processing unit configured to receive a data frame via the second port, the data frame including a destination address field, a source address field, a virtual network type field having a value indicative that the data frame includes a virtual network identifier field, at least one of a virtual network identifier type field and a virtual network identifier length field, the virtual network identifier field, either an e-type field or a data length field having a corresponding value indicating a protocol type or a length of a data field, respectively, and the data field, the virtual network identifier field having a value indicative of the LAN, the virtual network identifier type field having a value indicating a type of the virtual network identifier field and the virtual network identifier length field having a value indicating a length of the virtual network identifier field, the processing unit being further configured to read the virtual network identifier field in response to reading the virtual network type field and in accordance with the at least one of the virtual network identifier type field value and the virtual network identifier length field value, and to transmit the data frame toward the LAN via the first port.

18. The network device of claim 17 wherein the data frame includes both the virtual network identifier type field and the virtual network identifier length field.

19. The network device of claim 17, wherein the processing unit is configured to select the first port for transmission of the data frame based at least in part on the value of the virtual network identifier field.

## 14

20. The network device of claim 19, wherein the processing unit is configured to:

remove the virtual network type field and the virtual network identifier field and at least one of the virtual network identifier type field and virtual network identifier length field from the data frame; and

transmit the data frame toward the LAN via the first port without the virtual network type field and without the virtual network identifier field and without at least one of the virtual network identifier type field and virtual network identifier length field.

21. The network device of claim 20, wherein the processing unit is configured to:

calculate a frame check sequence for the data frame with the virtual network type field and the virtual network identifier field and at least one of the virtual network identifier type field and virtual network identifier length field removed; and

transmit the data frame toward the LAN via the first port with the calculated frame check sequence.

22. The network device of claim 17, wherein the value of the virtual network type field corresponds to Ethernet.

23. A network device comprising:

a first port configured to be coupled to a local area network (LAN);

a second port configured to be coupled to a shared communications medium;

a processing unit configured to receive a data frame via the second port, the data frame including a destination address field, a source address field, a virtual network type field having a value indicative that the data frame includes a virtual network identifier field, the virtual network identifier field, either an e-type field or a data length field having a corresponding value indicating a protocol type or a length of a data field, respectively, and the data field, the virtual network identifier field having a value indicative of the LAN, the processing unit being further configured to read the virtual network identifier field in response to reading the virtual network type field, and to transmit the data frame toward the LAN via the first port.

24. The network device of claim 23, wherein the processing unit is configured to select the first port for transmission of the data frame based at least in part on the value of the virtual network identifier field.

25. The network device of claim 24, wherein the processing unit is configured to:

remove the virtual network type field and the virtual network identifier field from the data frame; and

transmit the data frame toward the LAN via the first port without the virtual network type field and without the virtual network identifier field.

26. The network device of claim 25, wherein the processing unit is configured to:

calculate a frame check sequence for the data frame with the virtual network type field and the virtual network identifier field removed; and

transmit the data frame toward the LAN via the first port with the calculated frame check sequence.

27. The network device of claim 23, wherein the value of the virtual network type field corresponds to Ethernet.