



US00RE45495E

(19) **United States**
(12) **Reissued Patent**
Kim

(10) **Patent Number:** **US RE45,495 E**
(45) **Date of Reissued Patent:** ***Apr. 28, 2015**

(54) **LIQUID CRYSTAL DISPLAY AND METHOD OF FABRICATING THE SAME HAVING PARTICULAR DATA SIGNAL TRANSMISSION LINES**

G02F 1/134336; G02F 1/134327; G02F 1/134309; G02F 1/1393; G02F 1/13338; G06F 3/0413; G09G 3/3648

USPC 349/139, 142, 143, 151; 345/104
See application file for complete search history.

(75) Inventor: **Dong-Gyu Kim**, Yongin-si (KR)

(73) Assignee: **Samsung Display Co., Ltd.** (KR)

(*) Notice: This patent is subject to a terminal disclaimer.

(21) Appl. No.: **13/587,350**

(22) Filed: **Aug. 16, 2012**

Related U.S. Patent Documents

Reissue of:

(64) Patent No.: **7,538,843**
Issued: **May 26, 2009**
Appl. No.: **11/431,376**
Filed: **May 10, 2006**

U.S. Applications:

(62) Division of application No. 13/010,603, filed on Jan. 20, 2011, now Pat. No. Re. 43,684, which is a division of application No. 13/010,574, filed on Jan. 20, 2011, now Pat. No. Re. 43,701, which is an application for the reissue of Pat. No. 7,538,843.

(30) **Foreign Application Priority Data**

Sep. 12, 2005 (KR) 10-2005-0084740

(51) **Int. Cl.**
G02F 1/1343 (2006.01)
G02F 1/1345 (2006.01)
G09G 3/36 (2006.01)

(52) **U.S. Cl.**
CPC **G09G 3/3648** (2013.01)

(58) **Field of Classification Search**
CPC G02F 1/136286; G02F 1/133707;

(56) **References Cited**

U.S. PATENT DOCUMENTS

6,392,354 B1 * 5/2002 Matsueda 315/169.1
7,113,245 B2 * 9/2006 Murade 349/149

(Continued)

FOREIGN PATENT DOCUMENTS

JP 2001033757 A 2/2001
JP 2003149624 A 5/2003

(Continued)

Primary Examiner — Mike Qi

(74) *Attorney, Agent, or Firm* — Cantor Colburn LLP

(57) **ABSTRACT**

A liquid crystal display includes gate lines, data lines intersecting with the gate lines to define sub-pixels, and a transmission part including transmission lines connected with the data lines to transmit data signals, where at least one pair of the transmission lines are arranged to cross each other, some of the transmission lines cross each other so that a sequence of data signals applied to the data lines can be changed, any of the transmission lines is opened at a crossing point of the transmission lines and the opened portion is connected by a separate conductor, thereby insulating the transmission lines crossing each other from each other, and an additional process for connecting the opened portion is not needed, thereby simplifying a fabrication process for the liquid crystal display.

51 Claims, 9 Drawing Sheets

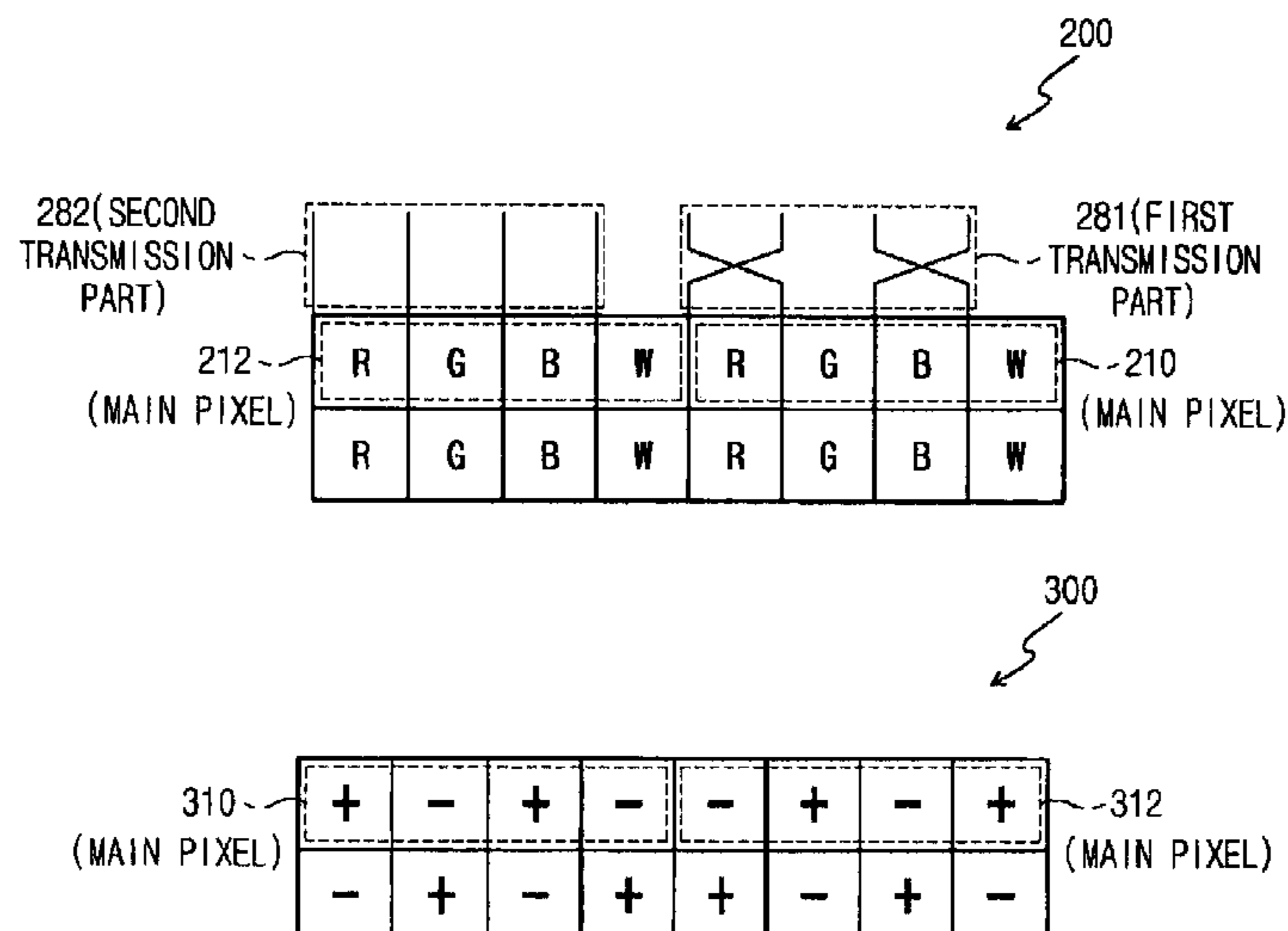

US RE45,495 E

Page 2

(56)

References Cited

FOREIGN PATENT DOCUMENTS

U.S. PATENT DOCUMENTS

7,259,755 B1 *	8/2007	Ahn	345/204
7,400,372 B2 *	7/2008	Yamazaki	349/121
7,538,843 B2 *	5/2009	Kim	349/139
RE43,684 E *	9/2012	Kim	349/149
RE43,701 E *	10/2012	Kim	349/139
2006/0139527 A1 *	6/2006	Chang et al.	349/114
2006/0187386 A1 *	8/2006	Roh	349/114
2008/0224978 A1 *	9/2008	Park	345/92
2008/0291347 A1 *	11/2008	Kim et al.	349/33

JP	2006084860	3/2006
JP	2006259135	9/2006
KR	1020000062850 A	10/2000
KR	1020040090295 A	10/2004
KR	1020050000644 A	1/2005
KR	1020050048317 A	5/2005
KR	1020050113853 A	12/2005
KR	1020060077952 A	7/2006
WO	03060869	7/2003

* cited by examiner

Fig. 1

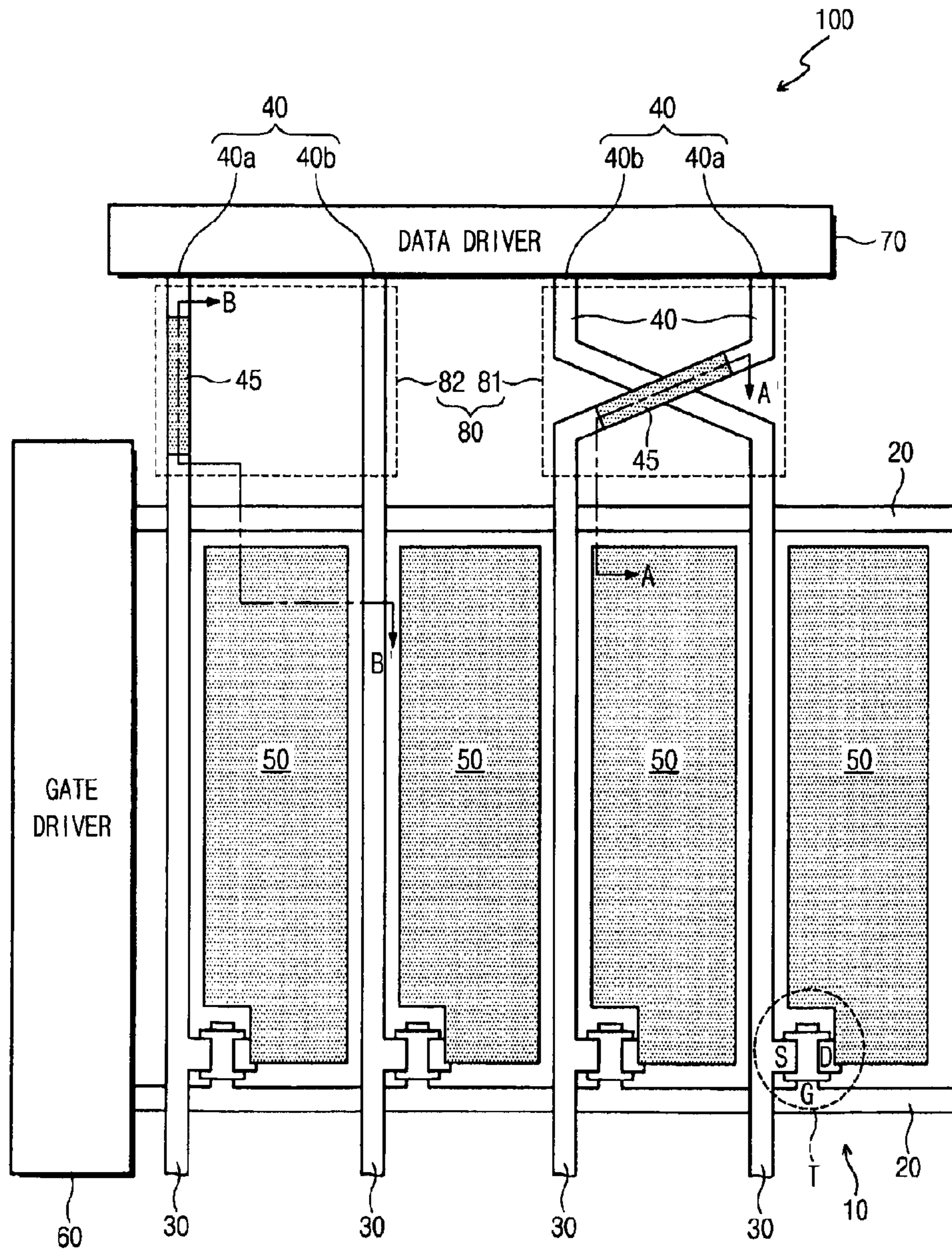

Fig. 2

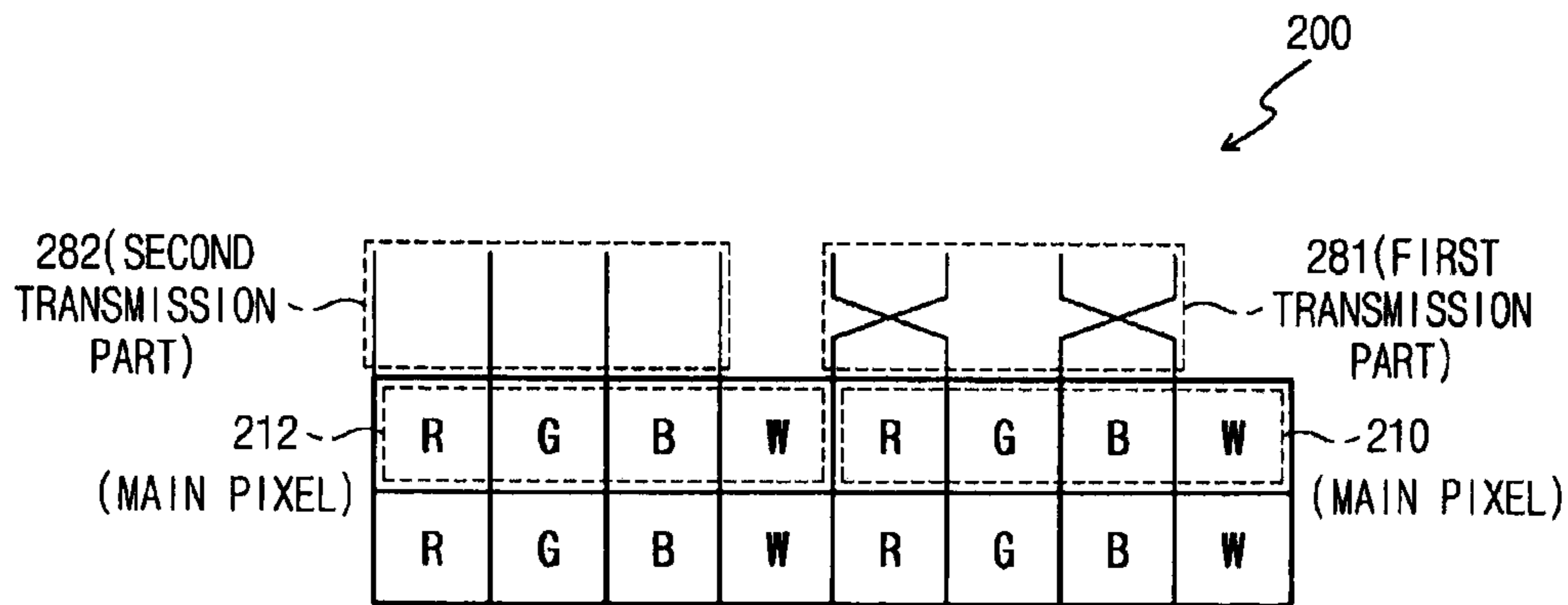

Fig. 3A

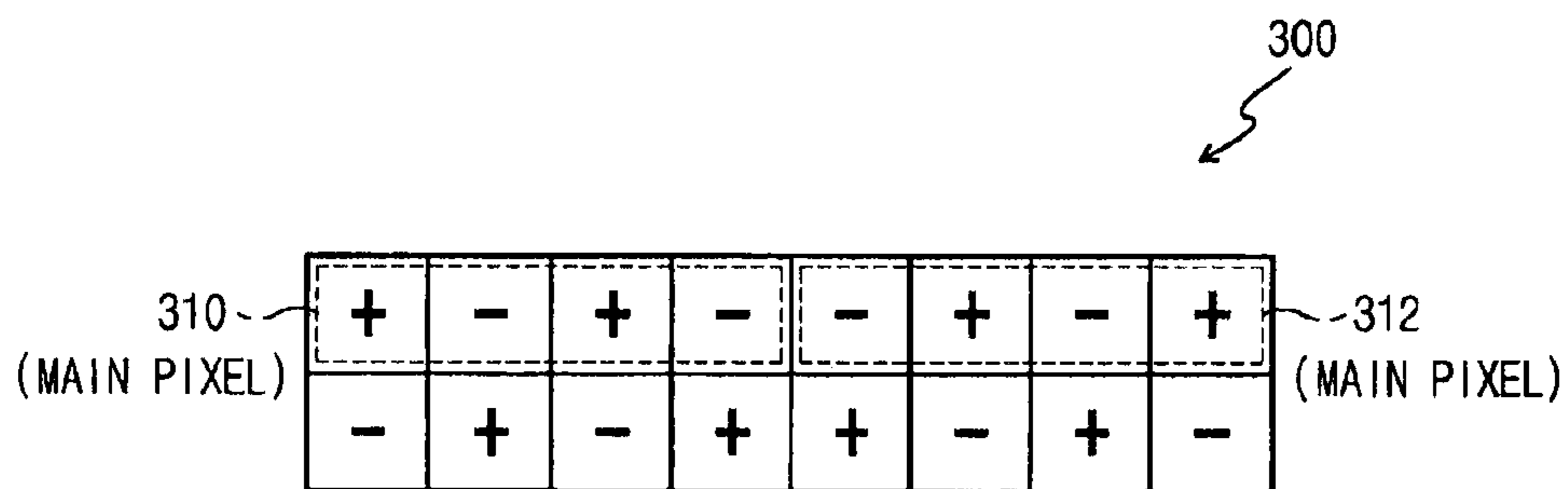

Fig. 3B

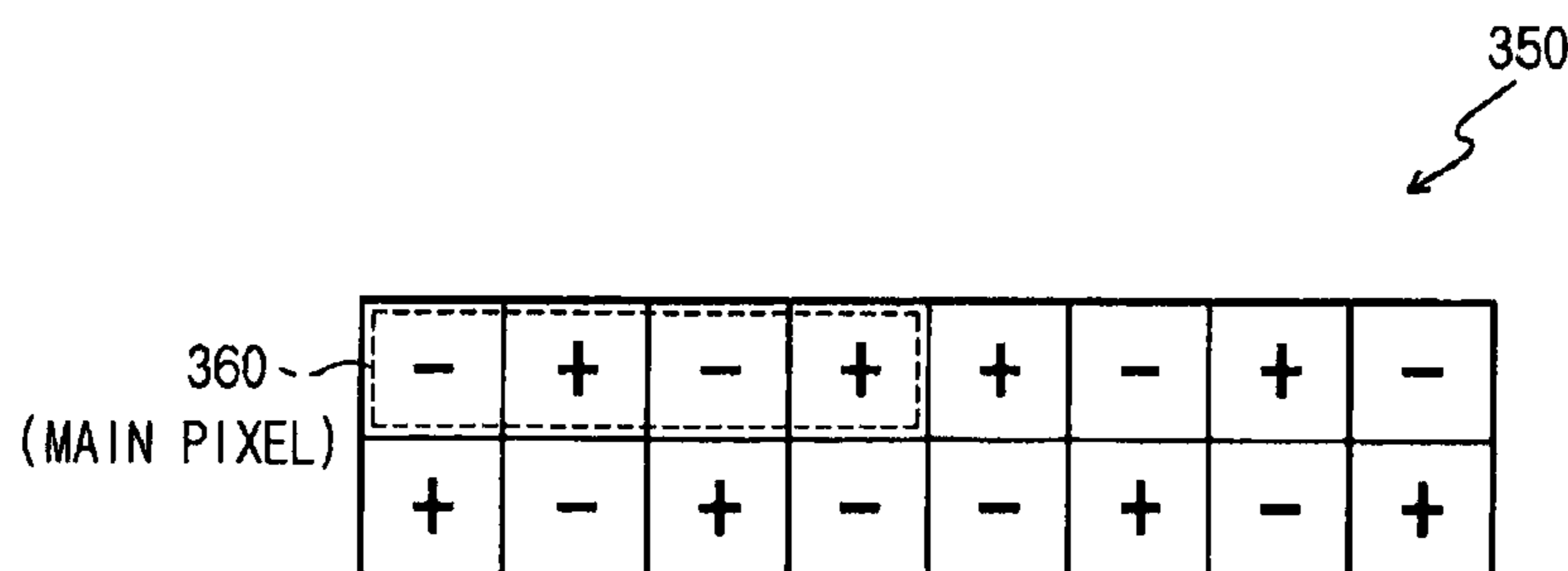

Fig. 4

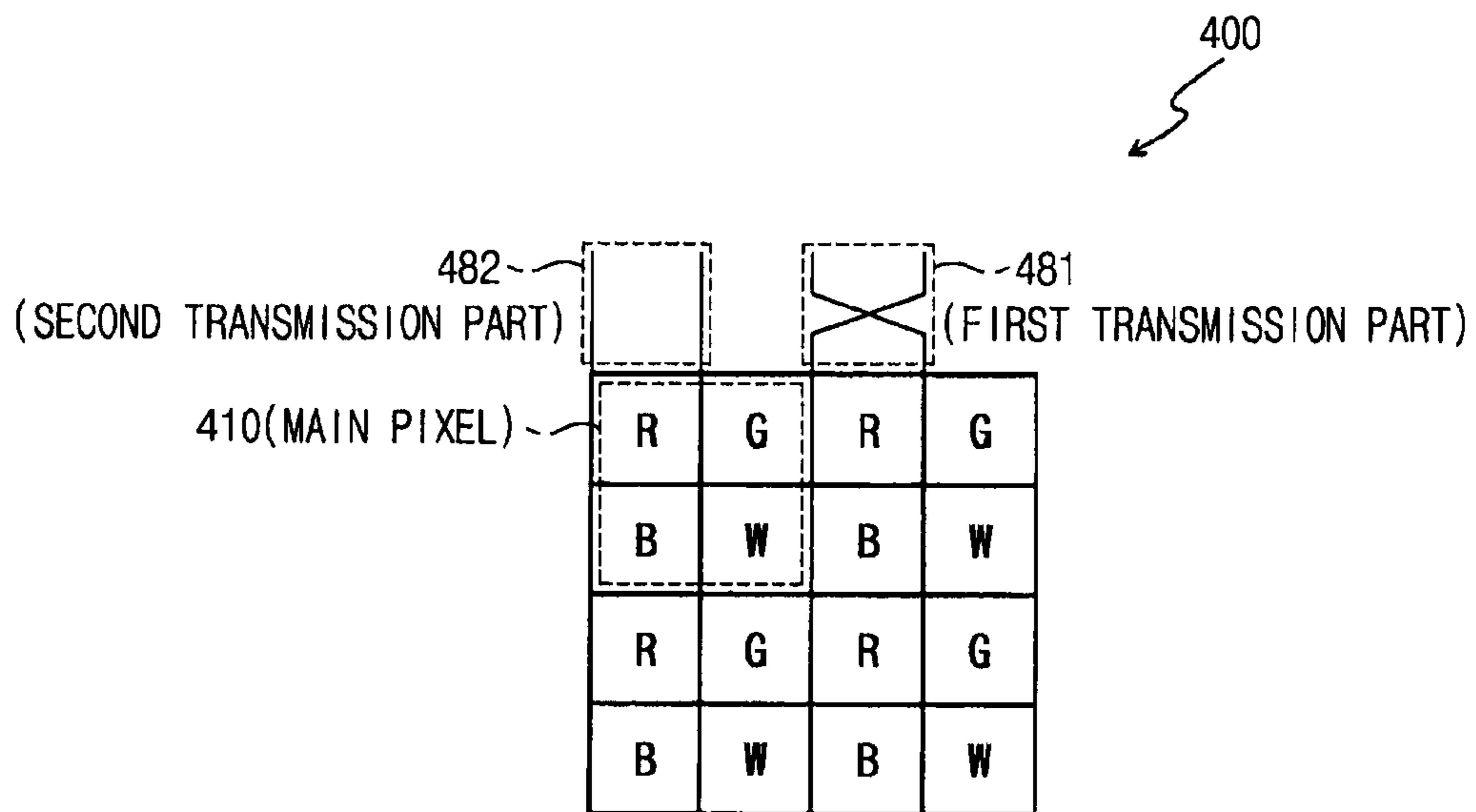

Fig. 5A

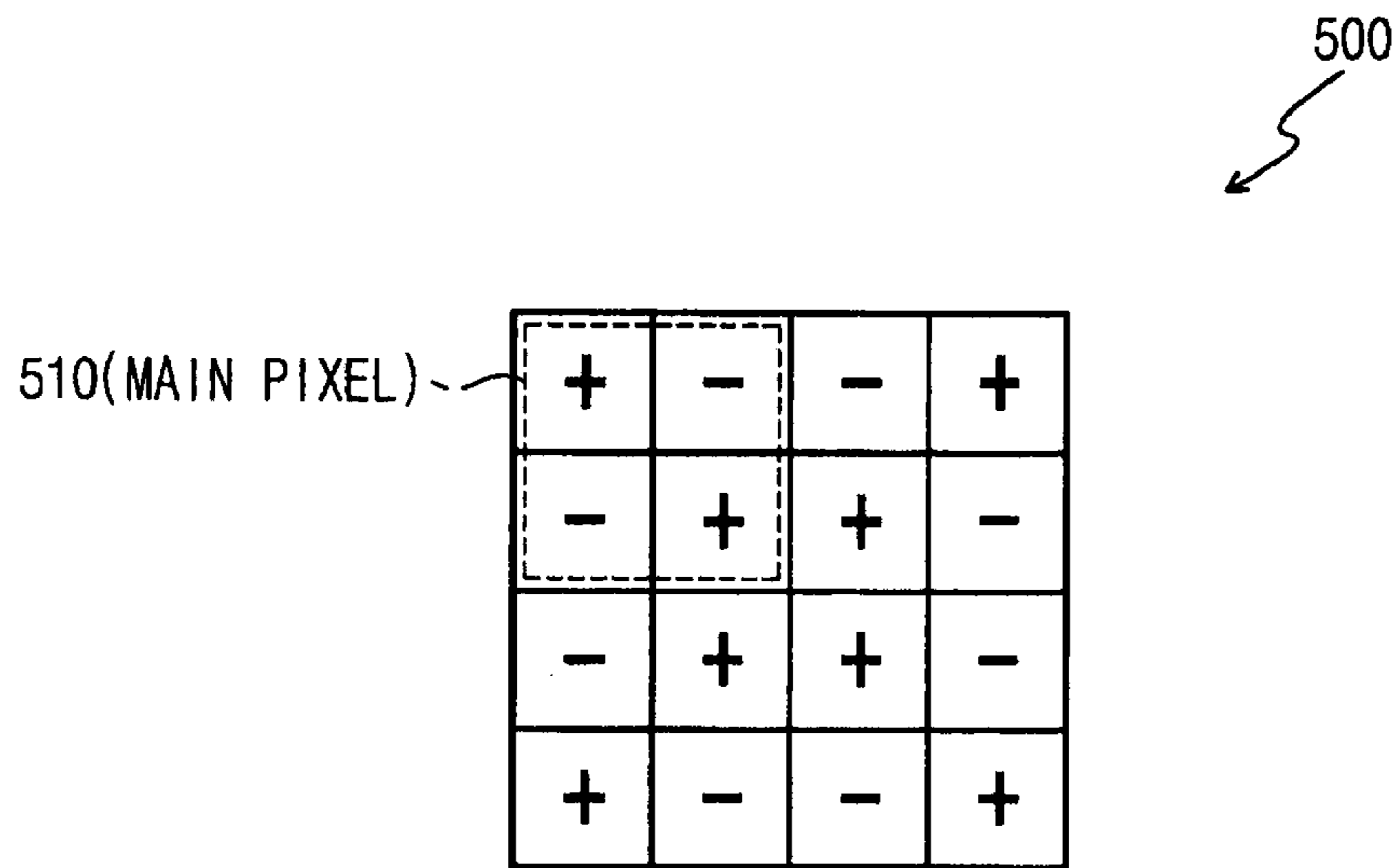

Fig. 5B

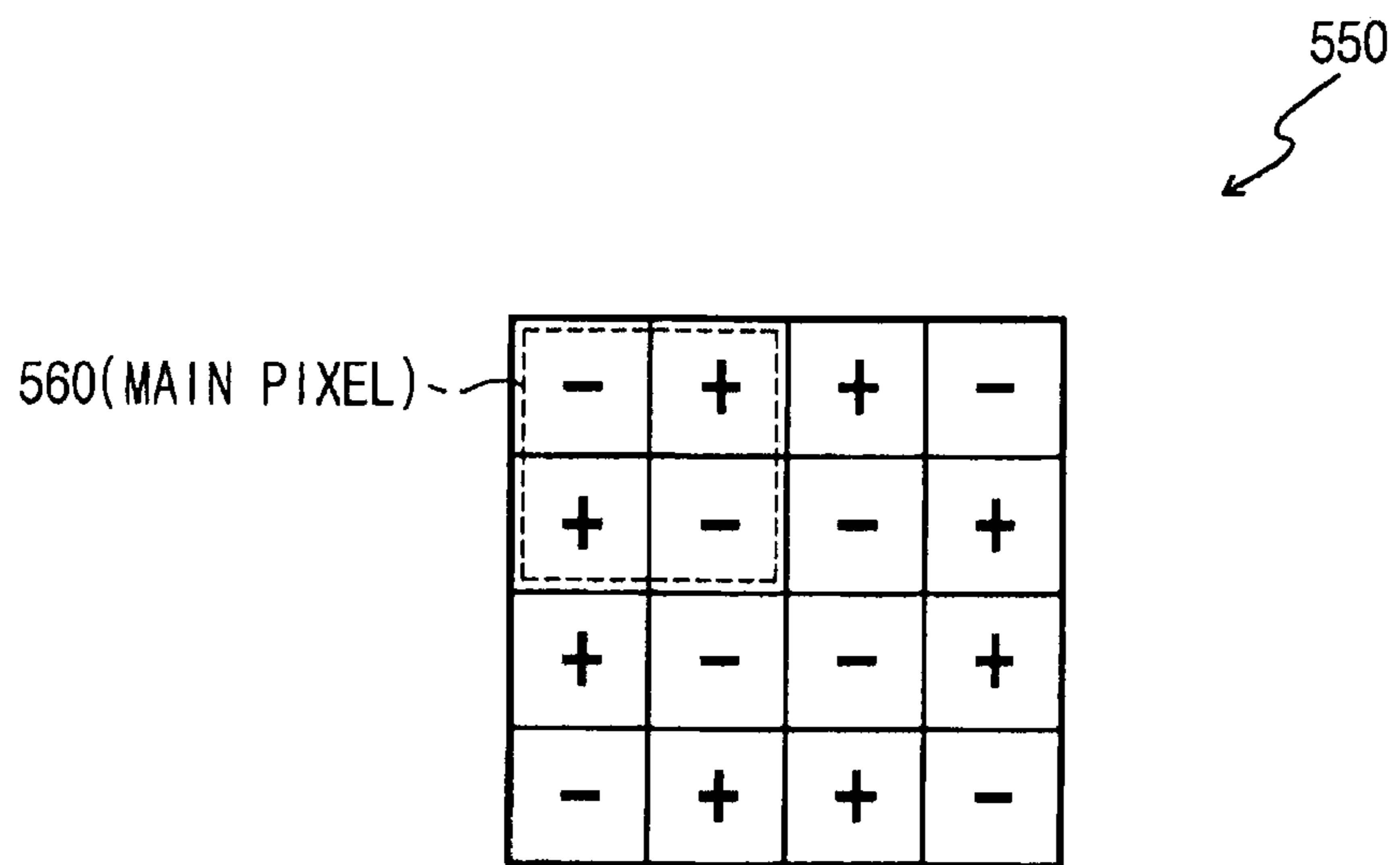

Fig. 6A

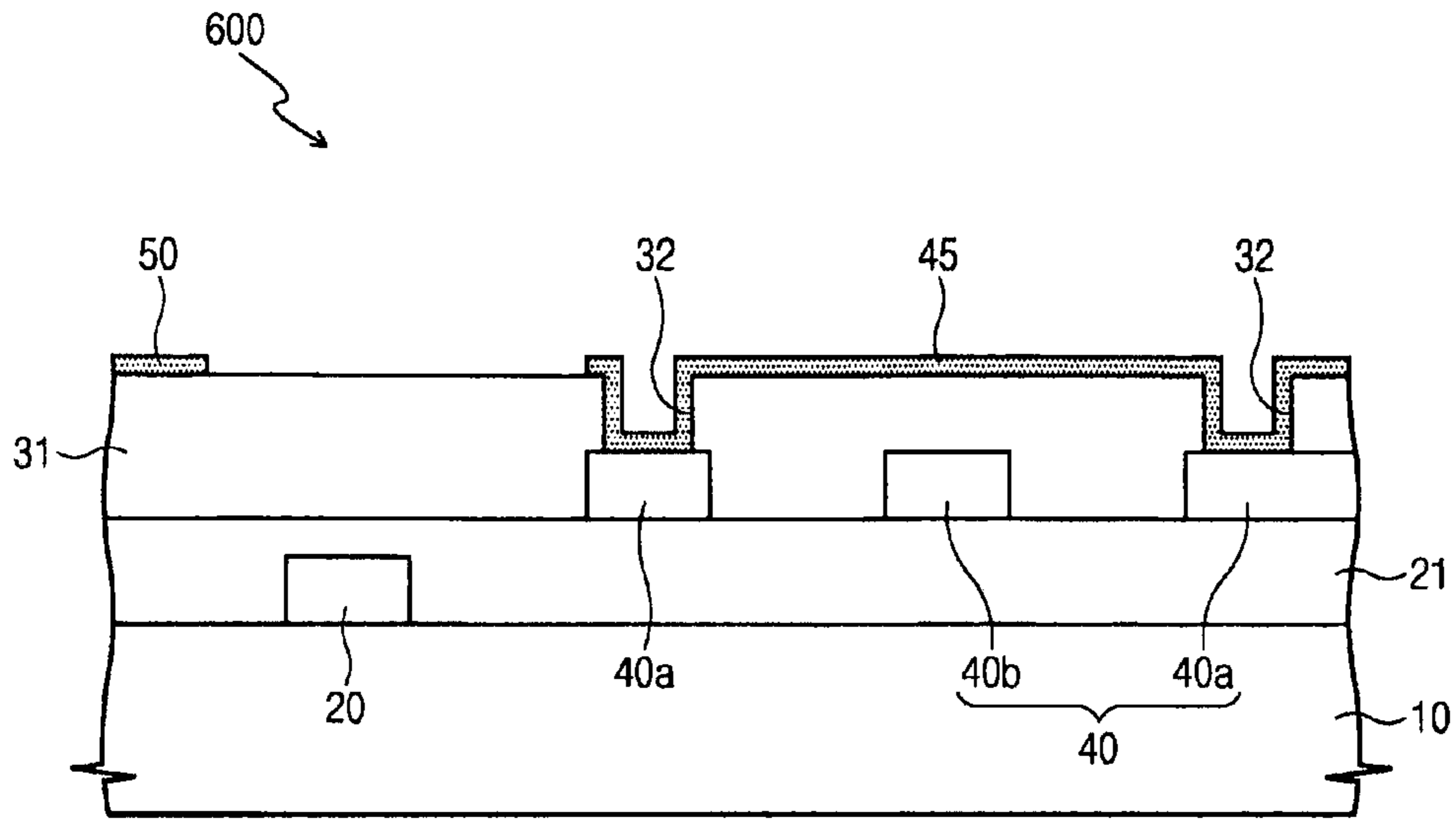

Fig. 6B

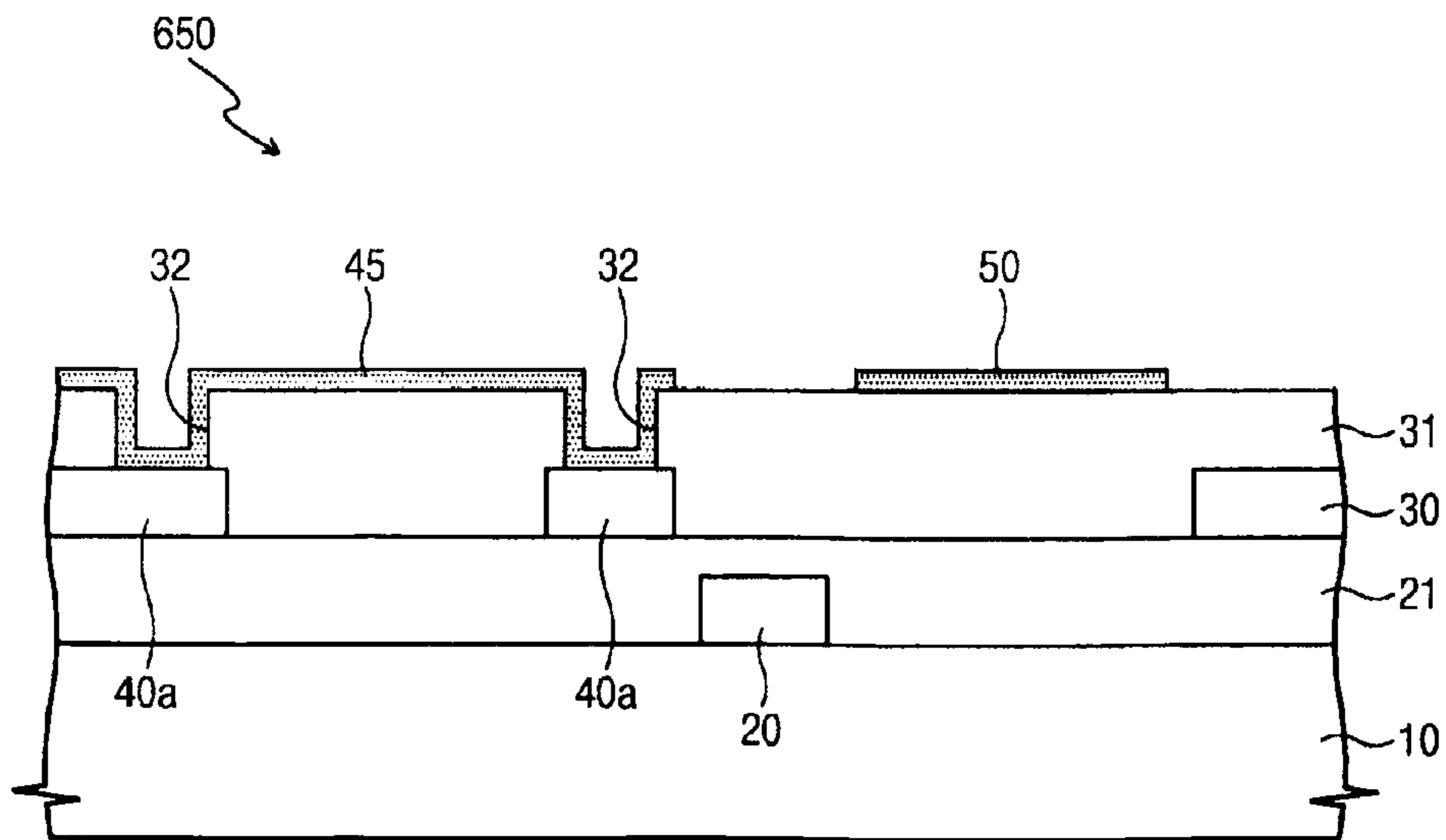

Fig. 7A

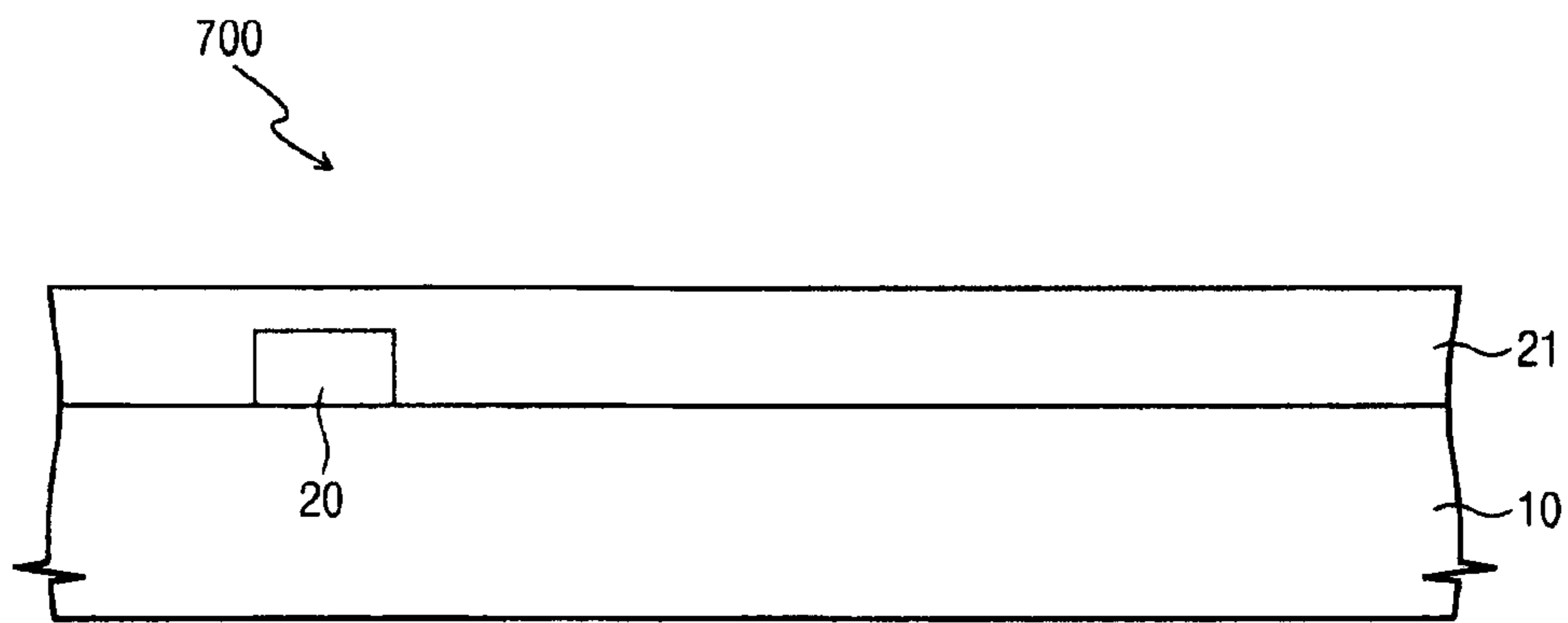

Fig. 7B

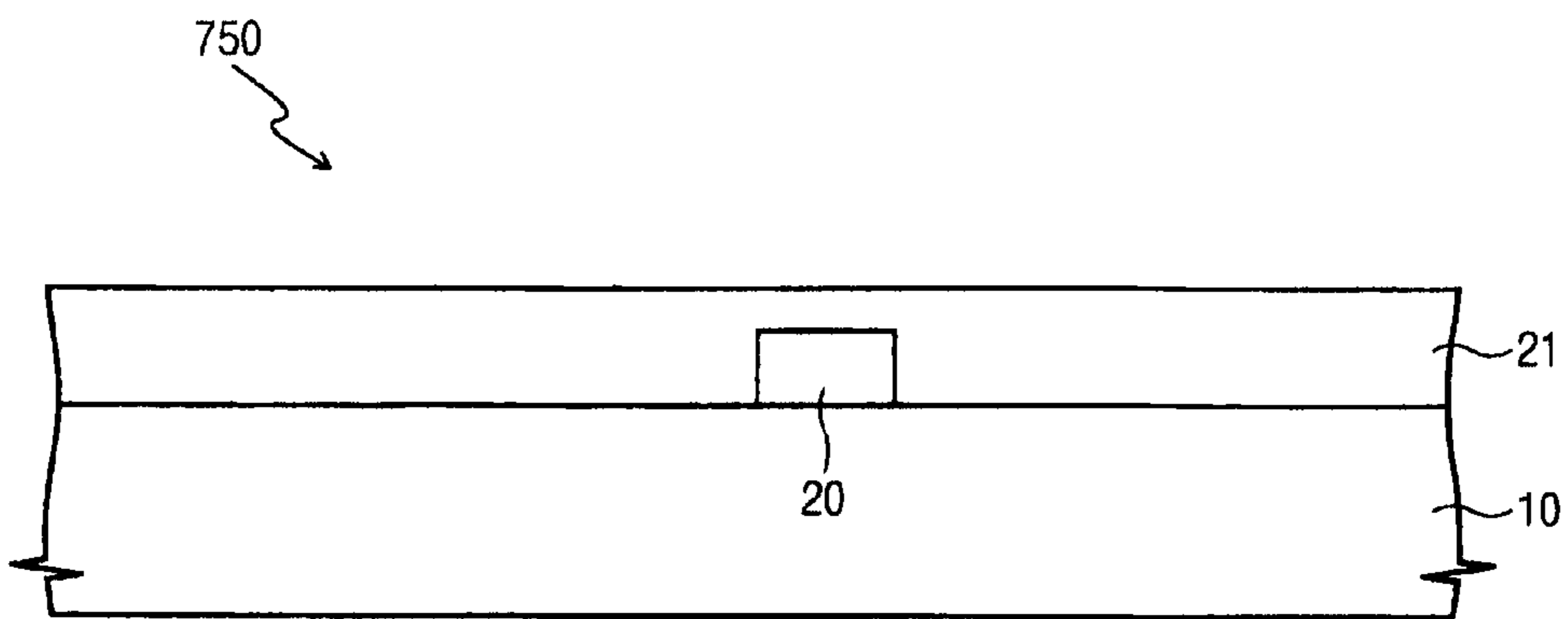

Fig. 8A

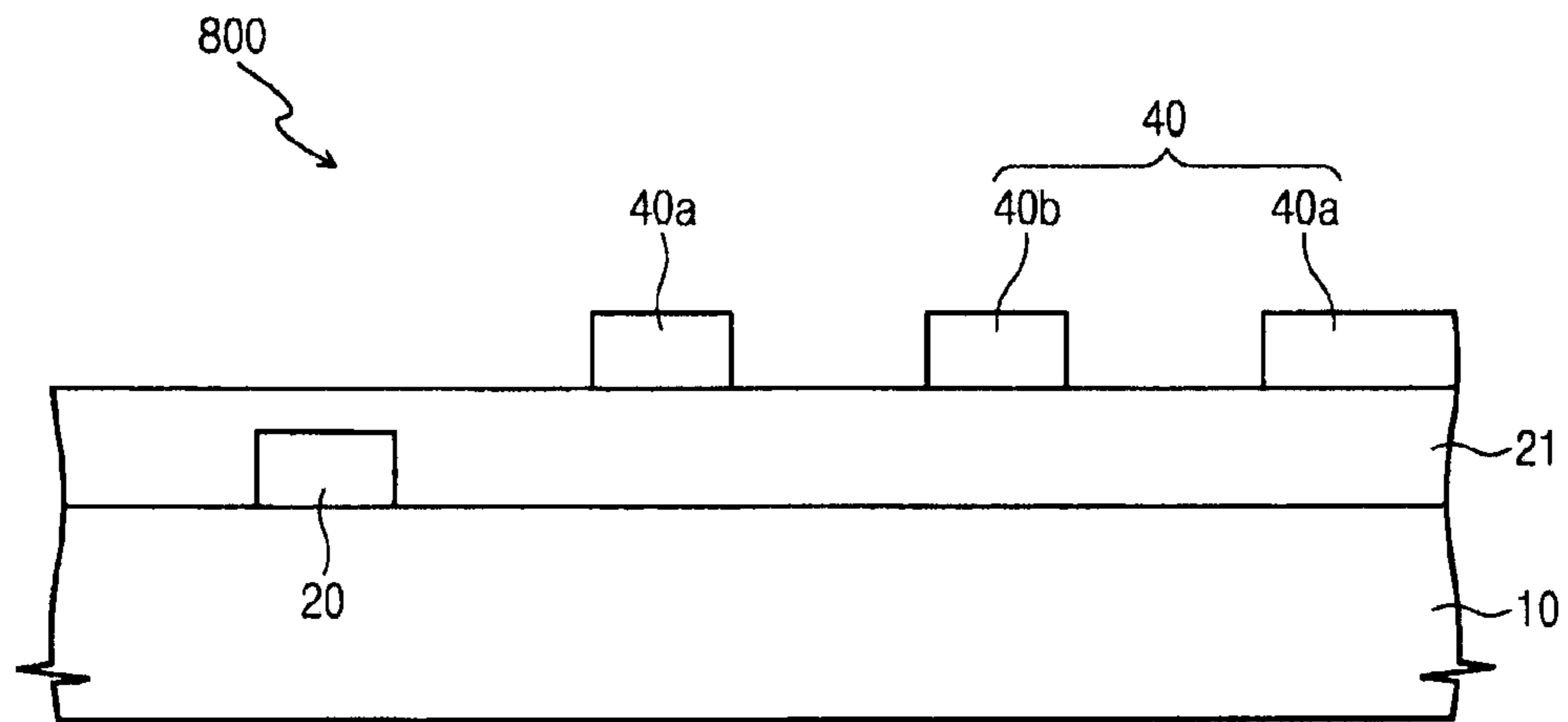

Fig. 8B

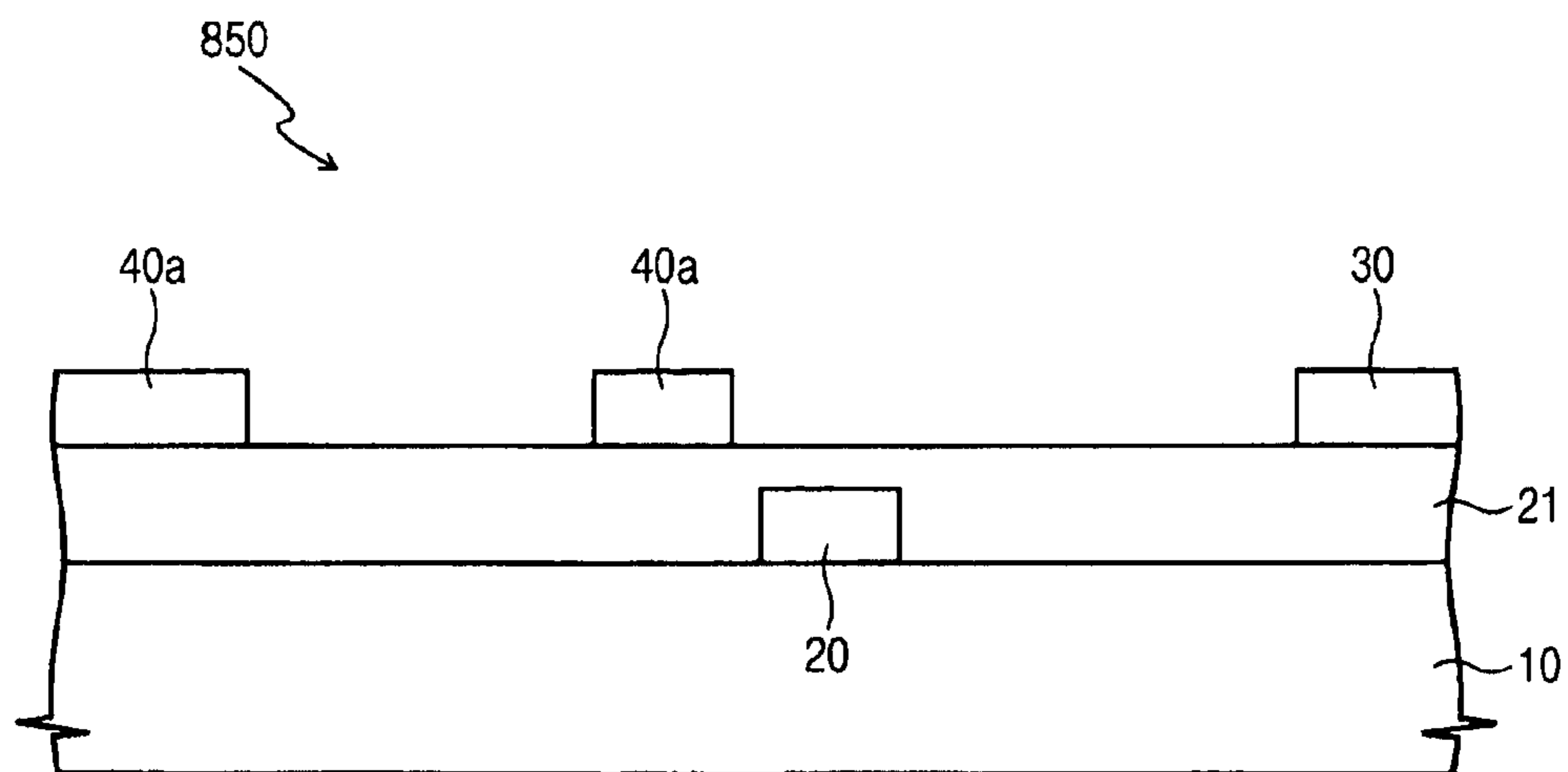

Fig. 9A

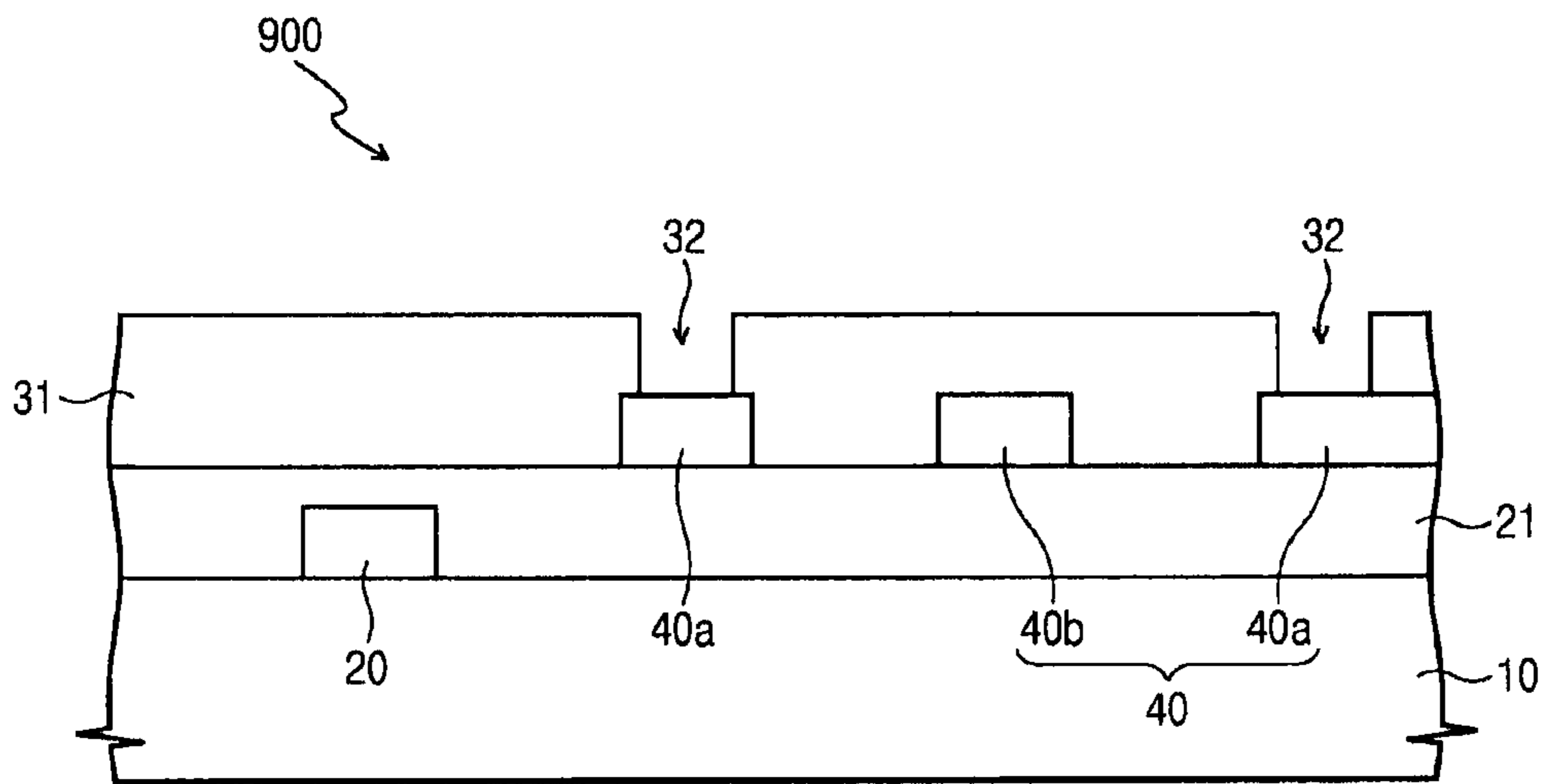

Fig. 9B

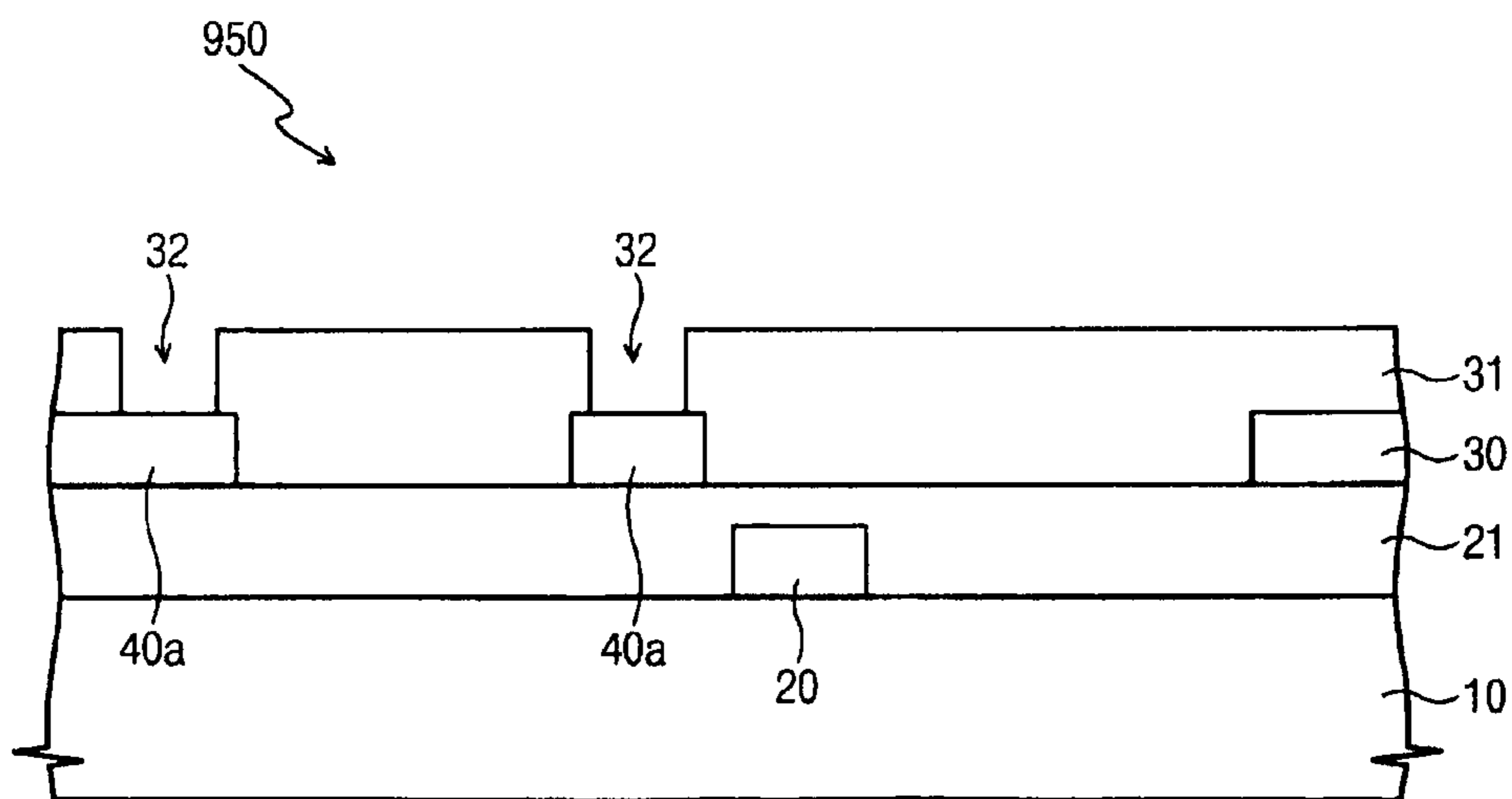

Fig. 10A

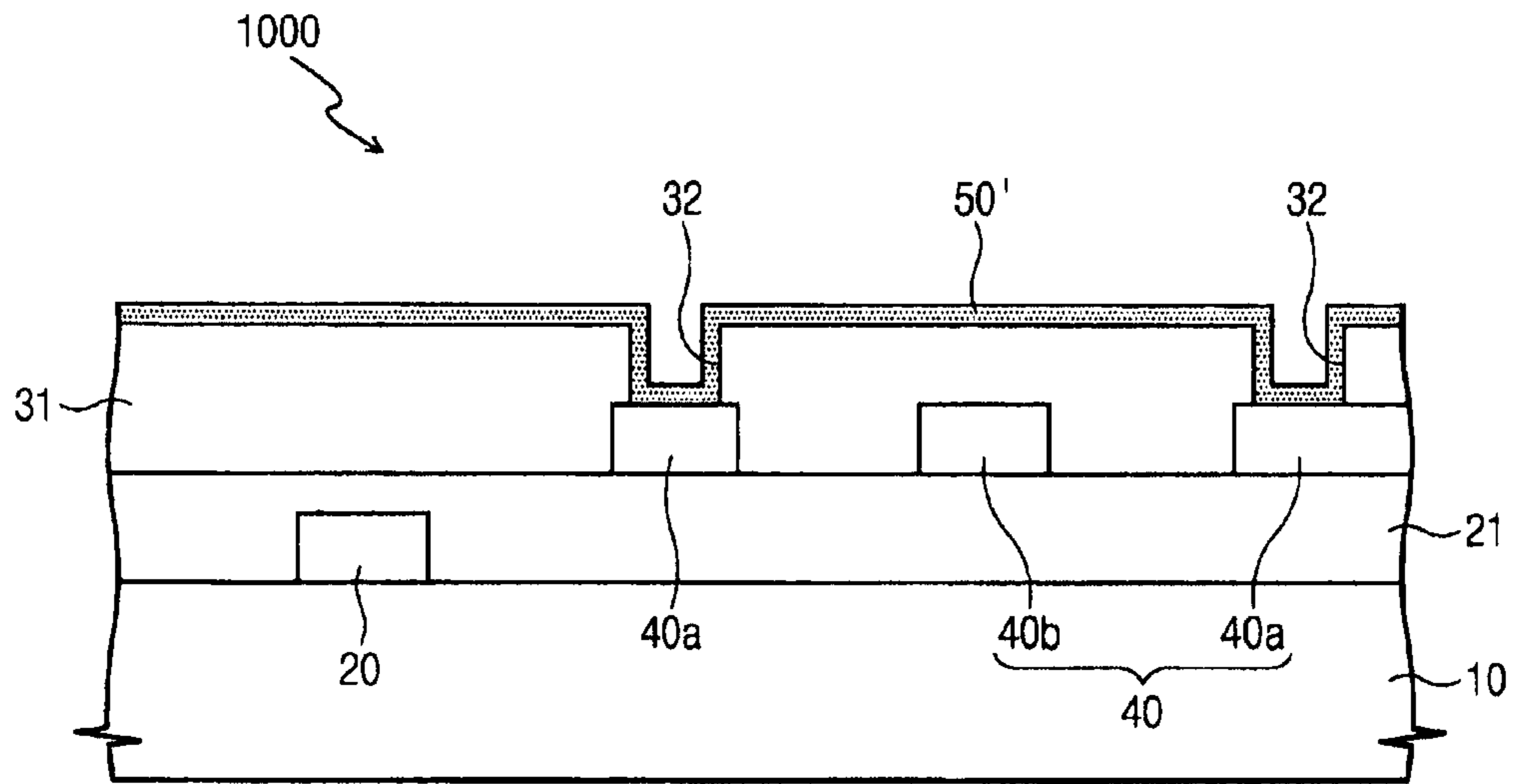
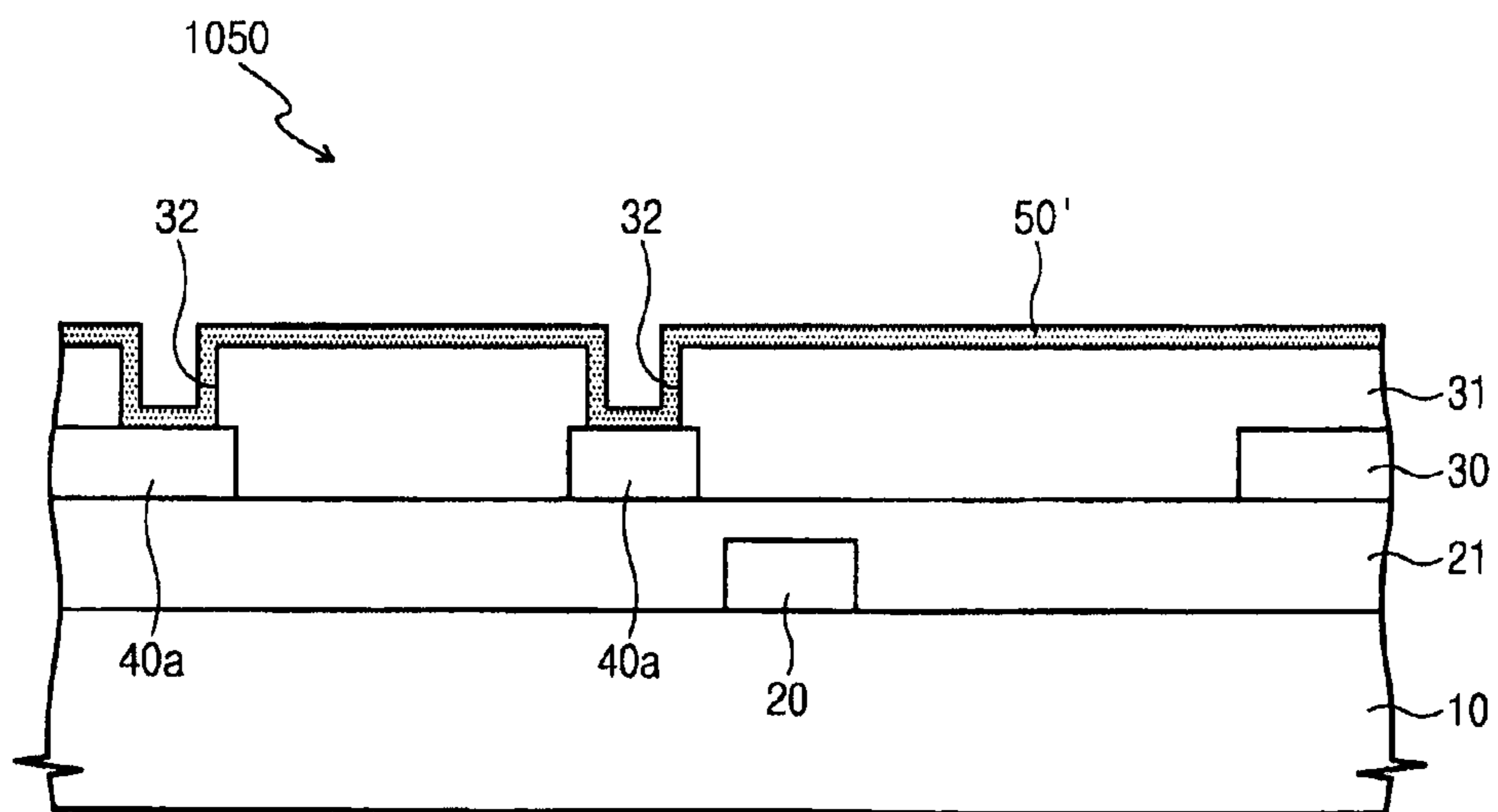

Fig. 10B



**LIQUID CRYSTAL DISPLAY AND METHOD
OF FABRICATING THE SAME HAVING
PARTICULAR DATA SIGNAL
TRANSMISSION LINES**

Matter enclosed in heavy brackets [] appears in the original patent but forms no part of this reissue specification; matter printed in italics indicates the additions made by reissue; a claim printed with strikethrough indicates that the claim was canceled, disclaimed, or held invalid by a prior post-patent action or proceeding.

CROSS-REFERENCE TO RELATED
APPLICATION

This application is a divisional application of application Ser. No. 13/010,574. More than one reissue application has been filed for the reissue of U.S. Pat. No. 7,538,843. The more than one reissue application are application Ser. No. 13/587,350 (the present application); application Ser. No. 13/010,574, filed on Jan. 20, 2011, which is now U.S. Pat. No. Re. 43,701 E; application Ser. No. 13/010,603, filed on Jan. 20, 2011, which is now U.S. Pat. No. Re. 43,684 E. This application claims foreign priority under 35 U.S.C. § 119 to Korean Patent Application No. 2005-84740, filed on Sep. 12, 2005, the contents of which are herein incorporated by reference in their entirety.

BACKGROUND OF THE INVENTION

1. Field of the Invention

The present disclosure relates to flat panel displays, and more particularly, to liquid crystal displays (LCDs) and methods of fabricating LCDs.

2. Description of the Conventional Art

A flat panel display (FDP) generally has a slim profile and provides a flat picture. One type of flat panel display is a liquid crystal display (LCD), which is widely used as a monitor of a notebook computer and the like. The LCD includes two substrates attached to each other, and a liquid crystal layer interposed between the two substrates. By applying different voltages to the two substrates, respectively, an electric field is formed. When the electric field is applied to the liquid crystal layer, liquid crystal molecules of the liquid crystal layer are re-aligned to vary a light transmittance of the liquid crystal layer, so that a desired image is displayed.

On a lower substrate of the two substrates, a plurality of pixels is regularly arranged. Each of the pixels includes a main pixel and a sub pixel. The sub pixel is to express colors. The sub pixels corresponding to a number of basic colors constitute a single main pixel. For example, when red (R), green (G) and blue (B) colors corresponding to three primary lights are used, a single main pixel includes three sub-pixels corresponding to the respective colors. Alternatively, the single main pixel includes four sub-pixels further including a white sub-pixel so as to increase a transmittance efficiency. The above three color sub-pixels structure and the four color sub-pixels structure have a difference in operation as follows.

A plurality of gate lines and a plurality of data lines intersecting the plurality of gate lines are formed on the lower substrate of an LCD. Regions defined by the plurality of gate lines and the plurality of data lines intersecting each other correspond to the sub-pixels, each having a pixel electrode formed thereon. Data signals are applied to the data lines and transmitted to pixel electrodes, so that an electric field is applied to the liquid crystal molecules of the liquid crystal

layer arranged on the pixel electrodes. Then, when the electric field is applied only in the same direction, the liquid crystal molecules are always inclined only in one direction due to a property of the liquid crystal, thereby deteriorating the liquid crystal molecules. To avoid such deterioration of the liquid crystal molecules, a positive (+) voltage and a negative voltage (-) are alternately applied to the pixel electrode. For the positive sub-pixels and the negative sub-pixels to be uniformly distributed, a data voltage with a different polarity is applied between sub-pixels adjacent to each other in a gate direction.

In the case of the three color sub-pixels structure, the sub-pixels arranged in the gate line direction are applied a data voltage with polarities, such as "red (+)/green (-)/blue(+)/red (-)/green(+)/blue(-) . . .". In the case of the four color sub-pixels structure, the sub-pixels arranged in the gate line direction are applied a data voltage with polarities, such as "red (+)/green (-)/blue(+)/white(-)/red(+)/green(-)/blue(+)/white(-) . . .".

In a case of the three color sub-pixels structure, the red sub-pixels are arranged with alternating positive polarity and negative polarity, whereas in a case of the four color sub-pixels structure, the red sub-pixels are arranged all only with the positive polarity. In other words, in the three color sub-pixels structure, since a number of the sub-pixels constituting the main pixel is an odd but the types of the polarity are two, their polarity correspondence is changed. In other words, the red sub-pixels have both the positive polarity and the negative polarity. In the four color sub-pixels structure, since the number of the sub-pixels constituting the main pixel is an even and the types of the polarity are two, their correspondence is not changed. In other words, the red sub-pixels have only one polarity in a specific frame.

When the sub-pixels of a specific color have only one polarity, an image display quality is lowered. In other words, while the polarity of the pixel electrode is periodically inverted from the positive polarity to the negative polarity or vice versa, the light transmittance of the liquid crystal layer is varied against the two polarities. For instance, in a case where only the red color is displayed, when a positive voltage is applied to all the red sub-pixels in a present frame and a negative voltage is applied to all the red sub-pixels in a next frame, a flicker occurs due to a transmittance difference between the opposite polarities during an inversion operation. Further, when only the positive voltage is applied to the sub-pixels, a voltage applied to the upper substrate is distorted. Thus, the electric field applied to the liquid crystal is greater or less than that in an ideal circumstance, thereby deteriorating the image display quality.

SUMMARY OF THE INVENTION

The present disclosure provides a liquid crystal display having an improved display quality. The present disclosure also provides a method suitable for fabricating the liquid crystal display.

An embodiment of the present disclosure provides a liquid crystal display including: a plurality of gate lines and a plurality of data lines formed to cross each other on a substrate and to define a plurality of sub-pixels; and a transmission part including a plurality of transmission lines connected with the plurality of data lines to transmit a data signal, at least one pair of the plurality of transmission lines being arranged to cross each other.

By using the transmission lines crossing each other, data signals generated in a data driver can be transmitted to the data lines in a changed sequence. For example, though data

3

signals are generated in a sequence of positive polarity and negative polarity, the data signals can be transmitted to the data lines in a sequence of negative polarity and positive polarity, if desired.

The transmission part may include a first transmission part including at least one pair of transmission lines crossing each other and a second transmission part including at least one pair of transmission lines that do not cross each other. The first transmission part and the second transmission part may be alternatively arranged in a gate line direction at each main pixel including the plurality of sub-pixels. In other words, in case the main pixel consists of sub-pixels of red/green/blue/white and data signals having a sequence of positive polarity and negative polarity that are alternatively generated from the data driver, a data signal having the positive polarity is transmitted to a first red sub-pixel from the first transmission part and a data signal having the negative polarity is transmitted to a second red sub-pixel from the second transmission part due to the transmission lines crossing each other. Thus, according to the present disclosure, data signals having the positive polarity and the negative polarity are uniformly transmitted to the sub-pixels having the same color, so that picture quality can be prevented from being lowered due to a concentration of the polarities toward a specific portion.

One pair of the transmission lines crossing each other should be insulated from each other, and any of one pair of the transmission lines is partially opened at a crossing point of one pair of the transmission lines. The opened portion can be connected by forming a separate conductor on the insulating layer on the transmission lines. An embodiment of the present disclosure can use a transparent conductive layer for forming a pixel electrode so as to form the conductor instead of adding a separate conductive layer.

Another embodiment of the present disclosure provides a method of fabricating a liquid crystal display. The method includes: forming a plurality of gate lines on a substrate; forming a plurality of data lines crossing the plurality of gate lines on the substrate; and forming a plurality of transmission lines connected with the plurality of data lines, at least one pair of the plurality of transmission lines being arranged to cross each other.

The plurality of transmission lines may include one pair of transmission lines crossing each other and one pair of transmission lines that do not cross each other, and one pair of the transmission lines crossing each other and one pair of the transmission lines that do not cross each other are uniformly arranged. The plurality of data lines and the plurality of transmission lines are simultaneously formed by depositing and patterning a metal film. A pixel electrode is formed on the plurality of data lines and the plurality of transmission lines by patterning a deposited transparent conductive layer. The metal film is patterned such that any of one pair of the transmission lines crossing each other is partially opened at a crossing point of one pair of the transmission lines, and the transparent conductive layer is patterned such that the opened portion is connected. In this case, the plurality of transmission lines is formed while the plurality of data lines and the pixel electrode are formed.

BRIEF DESCRIPTION OF THE DRAWINGS

The accompanying drawings, which are included to provide a further understanding of the disclosure and are incorporated in and constitute a part of this application, illustrate embodiment(s) of the disclosure and together with the description serve to explain principles of the disclosure. In the drawings:

4

FIG. 1 is a plane view showing a liquid crystal display according to an embodiment of the present disclosure;

FIG. 2 is a view showing a striped pixel pattern of a liquid crystal display according to an embodiment of the present disclosure;

FIGS. 3A and 3B show a status that data signals are applied to the pixel configuration of FIG. 2 in a dot inversion driving method;

FIG. 4 is a view showing a checkered pixel pattern of a liquid crystal display according to another embodiment of the present disclosure;

FIGS. 5A and 5B show a status that data signals are applied to the pixel configuration of FIG. 4 in a dot inversion driving method;

FIGS. 6A and 6B are cross-sectional views taken along lines A-A' and B-B' of FIG. 1, respectively; and

FIGS. 7A through 10A and FIGS. 7B through 10B are cross-sectional views taken along the lines A-A' and B-B', respectively, of FIG. 1 and illustrate a method of fabricating an LCD according to an embodiment of the present disclosure.

DETAILED DESCRIPTION OF PREFERRED EMBODIMENTS

The present disclosure will now be described more fully with reference to the accompanying drawings, in which exemplary embodiments are shown. The invention may, however, be embodied in many different forms and should not be construed as being limited to the embodiments set forth herein; rather, these embodiments are provided so that this disclosure will be thorough and complete, and will fully convey the concepts of the invention to those of ordinary skill in the pertinent art. In the drawings, the shapes of elements may be exaggerated for clarity. Like reference numerals in the drawings may denote like elements.

FIG. 1 is a plane view of a liquid crystal display (LCD) according to an embodiment of the present disclosure, indicated generally by the reference numeral **100**.

Referring to FIG. 1, gate lines **20** and data lines **30** intersecting with the gate lines **20** are formed on a substrate **10**. The gate lines **20** and the data lines **30** are generally arranged in a matrix configuration having a row direction and a column direction, respectively, to define a plurality of sub-pixel regions. Each of the sub-pixel regions has a sub-pixel formed therein. Thin film transistors 'T' and pixel electrodes **50**, connected with the thin film transistors (T), are formed within the sub-pixel regions. Each of the thin film transistors 'T' includes a gate electrode 'G' branched from a corresponding gate line of the gate lines **20**, a source electrode 'S' branched from a corresponding data line of the data lines **30**, and a drain electrode 'D' spaced apart from the source electrode 'S' and electrically connected with a corresponding pixel electrode of the pixel electrodes **50**.

Gate on signals are applied to the gate lines **20**, respectively, and data signals according to image information are applied to the data lines **30**, respectively. In other words, data signals applied to the data lines **30** may be applied to the pixel electrodes when the thin film transistors 'T' are turned on in response to the gate on signals.

Meanwhile, a substrate such as an upper substrate is separately disposed to face the substrate **10**. The upper substrate has a common electrode to which a reference voltage is applied. Also, a liquid crystal layer is interposed between the pixel electrodes **50** and the common electrode, and an electric field is applied to the liquid crystal layer due to a voltage

5

difference between a pixel voltage applied to the pixel electrodes **50** and the reference voltage applied to the common electrode.

Thus, while the LCD **100** operates, gate on signals and data signals are generated. For the generation of the gate on signals and data signals, the LCD **100** has a gate driver **60** and a data driver **70**. The data driver **70** is connected with the data lines **30** by a transmission part **80**. The transmission part **80** includes a plurality of transmission lines **40**, which are provided outside a pixel area, in the same number as the number of the data lines **30**, and connected with the data lines **30** on a one-to-one basis.

The transmission part **80** includes a first transmission part **81** and a second transmission part **82**. The first transmission part **81** includes at least one pair of transmission lines **40** crossing each other, and the second transmission part **82** includes at least one pair of transmission lines **40** substantially parallel with the data lines **30**. The second transmission part **82** transmits an n-th (where n is a natural number) data signal and an (n+1)-th data signal to the n-th data line and the (n+1)-th data line, respectively. The first transmission part **81** including the crossing transmission lines **40** transmits an n-th (where n is a natural number) data signal and an (n+1)-th data signal to the (n+1)-th data line and the n-th data line, respectively. Thus, the transmission part **80** including the crossing transmission lines **40** can be usefully used when it is required to change an overall aspect for applying the data signals to the data lines **30**. Meanwhile, some of the transmission lines **40** are partially opened and the opened portion of the transmission lines **40** are connected with a conductor **45**.

In cases where the data signals are generated alternating in the order of positive polarity and negative polarity by a dot inversion method or a column inversion method, positive/negative signals can be applied to the data lines **30** by properly using the crossing transmission lines **40**. Although the above embodiment shows and describes that two transmission lines **40** are crossed, the number of the crossing transmission lines can be increased such that the sequence of applying data signals is changed with respect to more data lines **30**. Since the data signals used in the LCDs have two types of polarities, i.e., positive polarity and negative polarity, an example of one pair of crossing transmission will now be described in detail.

FIG. **2** is a view showing a striped pixel pattern of an LCD according to an embodiment of the present disclosure, indicated generally by the reference numeral **200**. Referring to FIG. **2**, sub-pixels are defined on a region formed by intersecting gate lines in a row direction, and data lines in a column direction. In the striped pixel pattern **200**, the sub-pixels having the same colors are arranged in the column direction and the sub-pixels having the configuration of red (R)/green (G)/blue(B)/white(W) are repetitively arranged in the row direction. Four sub-pixels of red (R)/green (G)/blue(B)/white (W) arranged in the gate line direction constitute a main pixel. The first transmission part **281** and the second transmission part **282** are repetitively arranged in the row direction with respect to each main pixel. In other words, two pairs of the transmission lines **40** of FIG. **1** that cross each other are connected with respect to the first main pixel **210**, and two pairs of the transmission lines **40** that do not cross each other are connected with respect to the second main pixel **212**, and the above configuration is repeated.

FIGS. **3A** and **3B** each show a status, indicated generally by the reference numerals **300** and **350**, respectively, for data signals that are applied to the pixel configuration of FIG. **2** in a dot inversion driving method. The data driver **70** of FIG. **1** connected with the transmission part **80** of FIG. **1** alternatively generates the data signals having the positive polarity

6

and the negative polarity, respectively, and in a next frame, generates the data signals having the negative polarity and the positive polarity, respectively.

Referring to FIG. **3A**, in a case where the data signals having the alternate positive and negative polarities are generated, for example, “(+)/(-)/(+)/(-)/(+)/(-)/(+)(-),” a data signal having a polarity configuration of “(+)/(-)/(+)/(-)” is applied to a first main pixel **310** (represented by a dotted line) in a first row, and a data signal having a polarity configuration of “(-) (+)/(-)/(+)” is applied to a second main pixel **312** in the first row, which is because the sequence of the data signals is changed by the crossing transmission lines **40** of FIG. **1**. In this case, for example, the red sub-pixel has the positive polarity in the first main pixel **310** but has the negative polarity in the second main pixel **312**, so that the red sub-pixels are wholly distributed having the alternating positive and negative polarities. This configuration may alternately or additionally be applied to other color sub-pixels. Accordingly, the LCD can prevent the deterioration of picture display quality, such as flicker, for example.

A data signal having a polarity configuration of “(-)/(+)/(-)/(+)/(+)(-)/(+)(-)” is applied to sub-pixels in a second row according to 1×1 dot inversion method. In this case, the sub-pixels with the same color are wholly distributed having the alternate positive and negative polarities. If a column inversion driving method is applied to the LCD, the main pixel in the second row has the polarity configuration of “(+)/(-)/(+)(-)/(-)/(+)(-)/(+),” which is the same as that in the first row. In this case, the sub-pixels having the same color in the row direction can be distributed with alternate positive polarities and negative polarities,

FIG. **3B** shows the next frame status **350**. Referring to FIG. **3B**, in the next frame, the main pixel **360** and respective sub-pixels have the opposite polarities, and the data signals having the uniform positive polarities and negative polarities are applied to the sub-pixels having the same color as a whole.

FIG. **4** is a view showing a checkered pixel pattern, indicated generally by the reference numeral **400**, in an LCD according to another embodiment of the present disclosure. Referring to FIG. **4**, the sub-pixels are defined on region formed by intersecting the gate lines in a row direction and the data lines in a column direction. In the checkered pixel pattern, 2×2 sub-pixels arranged in a row direction and a column direction constitute a main pixel **410**. In other words, the main pixel includes two sub-pixels in the first row and two sub-pixels in the second row. For example, only red (R) and green (G) sub-pixels are repetitively arranged in the first row, and only blue (B) and white (W) sub-pixels are repetitively arranged in the second row. A first transmission part **481** and a second transmission part **482** are repetitively arranged in the row direction with respect to each main pixel. In other words, one pair of transmission lines that do not cross each other are connected with respect to the first main pixel **410**, and one pair of transmission lines crossing each other are connected with respect to the second main pixel, and the above configuration of the transmission lines is repeated.

FIGS. **5A** and **5B** each show a status, indicated generally by the reference numerals **500** and **550**, respectively, where data signals are applied to the pixel configuration of FIG. **4** in a dot inversion driving method. Referring to FIG. **5A**, in case where the data signals having the alternate positive polarity and negative polarity are generated, for example, “(+)/(-)/(+)(-),” the data signal having a polarity configuration of “(+)(-)/(-)” is applied to a first main pixel **510** (represented by a dotted line) in a first row, and the data signal having a polarity configuration of “(-)/(+)(-)” is applied to a second main pixel in the first row. Also, a data signal having a polarity configura-

tion of “(-)/(+)” is applied to a first main pixel **510** in a second row according to 1×1 dot inversion method and a data signal having a polarity configuration of “(+)/(-)” is applied to a second main pixel in the second row. In this case, for example, red (R) sub-pixels are distributed to alternately have the positive and negative polarities in the gate line direction. This configuration may additionally or alternately be applied to other color sub-pixels. Thus, since the two types of polarities are uniformly applied to the sub-pixels, the LCD can prevent the deterioration of picture display quality, such as flicker. Herein, a data signal having the same order of the polarities as that in the second row is applied to a main pixel in a third row, which is due to the application of 2×1 dot inversion driving method. By the 2×1 dot inversion driving method, the data signals with the different polarities can be applied to the sub-pixels adjacent in the column direction and having the same color.

FIG. **5B** shows the next frame status **550**. Referring to FIG. **5B**, in the next frame, the respective sub-pixels have the opposite polarities, and the data signals having the uniform positive polarities and negative polarities are applied to the main pixel **560** and sub-pixels having the same color as a whole.

As described above according to the present disclosure, data signals generated in the data driver are applied to the data lines in a changed sequence by changing the configuration of the transmission lines into the crossing configuration. In alternate embodiments, the above result can be achieved by modifying the design of the data driver without a structural change of the transmission lines. In other words, by changing the design of the data driver, it is possible to generate a data signal having the polarity configuration in the order of “R(+)/G(-)/B(+)/N(-)/R(-)/G(+)/B(-)/W(+)” in the gate line direction so as to be matched with the four color sub-pixel configuration, instead of generating the alternate positive and negative data signals in the gate line direction according to the conventional art. In this case, even in the four color sub-pixels configuration, a problem, such as flicker, can be avoided without any concentration of the polarities toward a specific portion. However, this alternate method requires a change in the design of the data driver, which causes a material cost to be increased and a yield to be decreased, compared with the exemplary embodiments of the present disclosure in which the configuration of the transmission lines is changed.

It is essentially required that all the transmission lines should be insulated from each other, which is equally applied to the crossing transmission lines of the first transmission part. Hereinafter, a vertical structure of the transmission lines designed to cross and be insulated from each other will be described with respect to the first transmission part.

FIGS. **6A** and **6B** are cross-sectional views taken along the lines A-A' and B-B' of FIG. **1**, respectively. FIGS. **6A** and **6B** show a vertical structure of a first transmission part **600** and a second transmission part **650**, respectively.

Referring to FIG. **6A**, transmission lines **40** crossing a gate line **20** are formed on a substrate **10**. The gate line **20** is insulated from the transmission lines **40** by a gate insulating layer **21** interposed therebetween. The transmission lines **40** are formed simultaneously with a data line **30** such that the transmission lines **40** are directly connected with the data line **30**. Then, since the data line **30** can be generally formed of a same material as that of the gate line **20**, the gate line **20** may be formed of a same material as that of the transmission lines **40**. A passivation layer **31** protecting a thin film transistor and the like is formed on the transmission lines **40**. The passivation layer **31** can be formed of a same material as that of the gate insulating layer **21**, and also serves as an insulator. The

transmission lines **40** on the gate insulating layer **21** are one pair crossing each other, and any of one pair of transmission lines **40** is opened at the crossing point such that they are insulated from each other.

Hereinafter, for the convenience of description, the two transmission lines **40** are respectively named as an opened transmission line **40a** and a non-opened transmission line **40b**. In the opened transmission line **40a**, an opened portion is connected by a conductor **45** on the passivation layer **31** through a contact hole **32**, while the non-opened transmission line **40b** passes over the opened transmission line **40b**. In other words, one pair of transmission lines **40** cross each other while being insulated by the non-opened transmission line **40b**, the opened transmission line **40a** and the conductor **45**. The conductor **45** is not limited in its shape or material if it can electrically connect the opened portions. Since a pixel electrode **50** is used as the conductor on the passivation layer **31** in a preferred LCD, it is preferable that the same material as that of the pixel electrode **50** be used as the conductor **45** in terms of the fabrication process.

Again referring to FIG. **1**, in addition to one pair of crossed transmission lines **40** of the first transmission part **81**, any of one pair of transmission lines **40** of the second transmission part **82** is also opened. The reason why the second transmission part **82** having the transmission lines not crossed with each other has the opened transmission line **40a** is to allow the opened transmission line **40a** of the second transmission part **82** to be equal in resistance to the opened transmission line **40a** of the first transmission part **81**. As described above, the transmission lines **40** can be formed of the same material as that of the gate line **20** or the data line **30**. The gate line **20** and the data line **30** can be formed of one selected from the group consisting of chromium (Cr), aluminum (Al), copper (Cu), Molybdenum (Mo) and alloys thereof, or in a multi-layer structure including two metal layers having different physical properties. In contrast, the pixel electrode **50** can be formed of a transparent conductive layer, such as indium zinc oxide (IZO) or indium tin oxide (ITO). If the conductor **45** connecting the opened portion of the first transmission part **81** is formed using the same material as that of the pixel electrode **50**, the opened transmission line **40a** in which the conductor **45** is used has a different resistance than the non-opened transmission line **40b**. In addition, even though the conductor **45** is formed of the same metal as that of the transmission lines **40**, if the transmission lines of the first transmission part **81** are different in length than the transmission lines of the second transmission part **82**, their resistances become different.

Assuming that FIG. **1** shows a checkered pixel pattern, the first transmission line **40** of the second transmission part **82** and the second transmission line **40** of the second transmission part **82** all transmit data signals for the same color. However, in a case where only one of two transmission lines includes an opened portion with respect to the same color, the resistance values of the respective transmission lines become different, so that different images may be displayed on the respective sub-pixels with respect to the same data signal. To avoid such a problem, it is preferred that the second transmission part **82** has the opened transmission line **40a**. At this time, the opened transmission lines **40a** of the first and second transmission parts **81** and **82** are properly selected such that they become lines applying data signals to the same color sub-pixels in the first transmission part **81** and the second transmission part **82**.

Next, a vertical structure in which the transmission lines **40** of the second transmission part **82** are opened will be described. Referring to FIG. **6B**, the gate line **20** and the gate

insulating layer **21** insulating the gate line are formed on the substrate **10**. A part of the data line **30** and the opened transmission line **40a** are formed on the gate insulating layer **21**, and are covered with the passivation layer **31**. The opened transmission line **40a** has a partially opened portion and the partially opened portion is connected with the conductor **45** on the passivation layer **31** through a contact hole **32**. The pixel electrode **50** is also formed on the passivation layer **31**, and the conductor **45** can be formed of the same material as that of the pixel electrode **50**.

In general, the resistance is proportional to the resistivity and length with respect to a medium but is inversely proportional to an area. Considering the above fact, in order to keep the resistances of the first transmission part **81**, the second transmission part **82** and the opened transmission line **40a** at constant values, the second transmission part **82** should be formed with an opened portion and also the material, length and line width of the conductor **45** connecting the opened portions should be properly adjusted. For instance, in case the conductors of the respective transmission parts **81** and **82** are formed of the same material, the areas and lengths of the conductors can be made to be substantially equal to each other, or in case any one of the conductors is longer than the other, the longer conductor **45** can be adjusted so as to have a [narrow] wide line width.

Hereinafter, a method of fabricating an LCD having the above construction will be described. FIGS. **7A** through **10A** are cross-sectional views taken along the line A-A' of FIG. **1**, indicated generally by the reference numerals **700**, **800**, **900** and **1000**, respectively, and FIGS. **7B** through **10B** are cross-sectional views taken along the line B-B' of FIG. **1**, indicated generally by the reference numerals **750**, **850**, **950** and **1050**, respectively. The cross-sectional views **700**, **800**, **900** and **1000** taken along the line A-A', and the cross-sectional views **750**, **850**, **950** and **1050** taken along the line B-B', illustrate a method of fabricating an LCD according to an exemplary embodiment of the present disclosure.

Referring to FIGS. **7A** and **7B**, a gate line **20** and a gate insulating layer **21** covering the gate line **20** are formed on a substrate **10**. The substrate **10** can be an insulator substrate, such as a transparent glass substrate or a transparent plastic substrate. The gate line **20** is formed by depositing a metal film using a sputtering, and patterning the deposited metal film. The gate insulating layer **21** can be formed by a chemical vapor deposition using silicon nitride (SiN_x) or silicon oxide (SiO_x).

Referring to FIGS. **8A** and **8B**, a data line **30** and transmission lines **40** are formed on the gate insulating layer **21**. The data line **30** and the transmission lines **40** connected with the data line **30** are substantially simultaneously formed by depositing and patterning a metal film on an entire surface of the gate insulating layer **21**. The transmission lines **40** include an opened transmission line **40a**, of which a predetermined portion is opened, and a non-opened transmission line **40b**, of which a corresponding predetermined portion is not opened. In a first transmission part **81** of FIG. **1**, any of one pair of transmission lines that cross each other is opened at a crossing point, and in a second transmission part **82** of FIG. **1**, any of one pair of transmission lines that do not cross each other is opened at a predetermined portion thereof.

A semiconductor layer of an amorphous silicon layer is formed at a crossing point between the gate line **20** and the data line **30** before the data line **30** and the like are formed. In addition, a gate electrode extending from the gate line **20** and a source electrode extending from the data line **30** are formed below and above the semiconductor layer, respectively, so that a thin film transistor is completed.

Referring to FIGS. **9A** and **9B**, a passivation layer **31** is deposited on an entire surface of the resultant substrate **10** to cover the data line **30** and the transmission lines **40**. The passivation layer **31** can be formed by a chemical vapor deposition using silicon nitride or the like, much like the gate insulating layer **21**. The passivation layer **31** is then patterned by a photolithography process to form a contact hole **32** at a predetermined portion thereof. The contact hole **32** is used to electrically connect a pixel electrode **50** formed on the passivation layer **31** in a subsequent process with the thin film transistor. In addition to the above contact hole, another contact hole used as a path for electrically connecting the opened portion of the transmission lines **40** is formed during the above patterning process.

Referring to FIGS. **10A** and **10B**, a transparent conductive layer **50'** is deposited on the passivation layer **31** using IZO or the like. The transparent conductive layer **50'** is filled in the contact hole **32** and is directly contacted with an upper surface of the opened transmission line **40a**.

Thereafter, the transparent conductive layer **50'** is patterned to form a conductor **45** connecting the pixel electrode **50** and a conductor **45** connecting the opened portion of the opened transmission line **40a**, so that the resultant substrates shown in FIGS. **6A** and **6B** are completed. The pixel electrode **50** is formed every sub-pixel such that the sub-pixel is separated from an adjacent sub-pixel thereto, and is connected with the thin film transistor through the contact hole. In addition, the transparent conductive layer **50'** is partially remained on the opened portion of the opened transmission line **40a** such that the opened portion is electrically connected. To connect the opened portion using the conductor **45** that is different from the IZO or the like, a further process to deposit and pattern a separate metal film is needed before or after the pixel electrode **50** is formed.

An exemplary method of fabricating the LCD according to the present disclosure has been described with reference to the accompanying drawings. Since the above method is one of a variety of methods for fabricating the LCD shown in FIG. **1A**, the LCD may be fabricated by alternate methods. Preferably, the fabrication method according to the present disclosure uses the same material as that of the pixel electrode so as to form the conductor for connecting the opened portion of the transmission line such that the opened portion is connected while the pixel electrode is formed, thereby simplifying the fabrication method.

As described above according to exemplary embodiments of the present disclosure, in an LCD having four color sub-pixels, a data signal having the alternate positive polarity and negative polarity can be uniformly applied to sub-pixels with the same color by using transmission lines crossing each other. Accordingly, the picture quality can be prevented from being lowered due to a concentration of the same polarities on a specific portion.

In addition, in forming the transmission lines crossing each other, any of the transmission lines is opened at a crossing point, and the opened portion is electrically connected during the formation of the pixel electrode. Thereby, an additional process for connecting the opened portion is not needed, so that the fabrication process is simplified.

It will be apparent to those of ordinary skill in the pertinent art that various modifications and variations can be made in the exemplary embodiments of the present disclosure. Thus, it is intended that the present invention covers all such modifications and variations that come within the scope of the appended claims and their equivalents.

11

What is claimed is:

[1. A liquid crystal display comprising:
a plurality of gate lines formed on a substrate;
a plurality of data lines formed on the substrate and inter-
secting with the gate lines to define a plurality of sub-
pixels; and
a transmission part including a plurality of transmission
lines connected with the data lines to transmit a data
signal, at least one pair of the transmission lines being
arranged to cross each other.]

[2. The liquid crystal display of claim 1, wherein the trans-
mission part comprises a first transmission part including at
least one pair of the transmission lines crossing each other and
a second transmission part including at least one pair of the
transmission lines that do not cross each other.]

[3. The liquid crystal display of claim 2, wherein the sub-
pixels comprise two or more sub-pixels constituting a main
pixel, and the first transmission part and the second transmis-
sion part are alternatively arranged in each main pixel in a
gate line direction.]

[4. The liquid crystal display of claim 3, further comprising
a passivation layer covering the data lines and the transmis-
sion part, and a pixel electrode on the passivation layer cor-
responding to each sub-pixel.]

[5. The liquid crystal display of claim 4, wherein any of one
pair of the transmission lines of the first transmission part is
partially opened at a crossing point of the transmission lines,
further comprising a first conductor connecting the opened
portion on the passivation layer.]

[6. The liquid crystal display of claim 5, wherein the first
conductor comprises a same material as that of the pixel
electrode.]

[7. The liquid crystal display of claim 5, wherein any of one
pair of the transmission lines of the second transmission part
is partially opened at not a crossing point of the transmission
lines, further comprising a second conductor connecting the
opened portion on the passivation layer.]

[8. The liquid crystal display of claim 7, wherein the first
conductor has a same resistance value as that of the second
conductor.]

[9. The liquid crystal display of claim 7, wherein the first
and second conductors comprise a same material as that of the
pixel electrode.]

[10. The liquid crystal display of claim 3, further compris-
ing a data driver generating data signals, wherein the data
signals are applied to the data lines in a changed sequence by
the transmission lines crossing each other.]

[11. The liquid crystal display of claim 10, wherein the
main pixel comprises 1 by 4 sub-pixels arranged in the gate
line direction.]

[12. The liquid crystal display of claim 10, wherein the
main pixel comprises 2 by 2 sub-pixels arranged in the gate
line direction and a data line direction.]

[13. The liquid crystal display of claim 10, wherein the
main pixel comprises the four sub-pixels expressing red,
green, blue and white colors, respectively.]

[14. A method of fabricating a liquid crystal display, the
method comprising:

forming a plurality of gate lines on a substrate;
forming a plurality of data lines crossing the gate lines on
the substrate; and
forming a plurality of transmission line connected with the
data lines, at least one pair of the transmission lines
being arranged to cross each other.]

12

[15. The method of claim 14, wherein the transmission
lines comprise at least one pair of transmission lines crossing
each other and at least one pair of transmission lines that do
not cross each other.]

[16. The method of claim 14, wherein the data lines and the
transmission lines are substantially simultaneously formed
by depositing and patterning a metal film.]

[17. The method of claim 16, further comprising:
forming an insulating layer on the data lines and the trans-
mission lines;
depositing a transparent conductive layer on the insulating
layer; and
patterning the deposited transparent conductive layer to
form a pixel electrode.]

[18. The method of claim 17, wherein the metal film is
patterned so any of one pair of the transmission lines crossing
each other is partially opened at a crossing point of the pair of
the transmission lines, and the transparent conductive layer is
patterned so the opened portion is connected.]

[19. The method of claim 18, wherein the transparent con-
ductive layer is substantially simultaneously patterned when
the pixel electrode is formed.]

[20. The method of claim 19, wherein the metal film is
patterned so any of one pair of the transmission lines that do
not cross each other is partially opened, and the transparent
conductive layer is substantially simultaneously patterned
when the pixel electrode is formed to connect the opened
portion.]

21. A display device comprising:
a substrate including a display area and a peripheral area
which surrounds at least a portion of the display area;
a plurality of main pixels disposed in the display area, each
of the plurality of main pixels including at least $2n$
sub-pixels, wherein n is an integer greater than one;
a data driver which supplies polarity signals to the plural-
ity of main pixels; and
a transmission member disposed between the data driver
and the plurality of main pixels, wherein the transmis-
sion member receives a first arrangement of polarity
signals from the data driver and outputs a second
arrangement of polarity signals, wherein the first
arrangement of polarity signals is different from the
second arrangement of polarity signals,
wherein a polarity of the polarity signals applied to same-
colored sub-pixels of two adjacent main pixels in a row
direction are opposite from each other.

22. The display device of claim 21, wherein the plurality of
main pixels comprises a first main pixel connected to the first
transmission part and a second main pixel connected to the
second transmission part.

23. The display device of claim 22, wherein a first sub-pixel
of the first main pixel has a first color and a first sub-pixel of
the second main pixel has the first color, and
wherein a polarity of the first sub-pixel of the first main
pixel and a polarity of the first sub-pixel of the second
main pixel are different from each other.

24. The display device of claim 23, wherein each main pixel
comprises four sub-pixels,
wherein each sub-pixel of the four sub-pixels of each main
pixel comprises one of the first color, a second color, a
third color, and a fourth color,
wherein each sub-pixel of the four sub-pixels of each main
pixel has a different color, and
wherein the first color, the second color, the third color and
the fourth color are different from one another.

13

25. The display device of claim 24, wherein each main pixel of the plurality of main pixels comprises four sub-pixels arranged in the row direction

26. The display device of claim 25, wherein a polarity sequence of sub-pixels in the first main pixel and the second main pixel comprises (+)(-)(+)(-)(-)(+)(-)(+) in a first frame.

27. The display device of claim 26, wherein a polarity sequence of sub-pixels in the first main pixel and the second main pixel comprises (-)(+)(-)(+)(+)(-)(+)(-) in a frame which is subsequent to the first frame.

28. The display device of claim 26, wherein the first transmission part comprises a first transmission line of the at least one pair of transmission lines which cross each other has an opened portion disposed therein,

wherein the first transmission line further comprises a first conductor disposed in the opened portion.

29. The display device of claim 28, wherein the first transmission line has a width which is different than a width of a second transmission line of the at least one pair of transmission lines which do not cross each other.

30. The display device of claim 28, wherein the first conductor comprises at least one of indium zinc oxide and indium tin oxide.

31. The display device of claim 21, wherein the plurality of gate lines comprise a multi-layered structure including at least two metal layers, and wherein at least two of the at least two metal layers have different physical properties from each other.

32. The display device of claim 31, wherein the plurality of data lines comprise a multi-layered structure including at least two metal layers, and wherein at least two of the at least two metal layers have different physical properties from each other.

33. The display device of claim 21, wherein the plurality of gate lines comprise at least one of chromium, aluminum, copper, molybdenum and alloys thereof.

34. The display device of claim 33, wherein the plurality of data lines comprise at least one of chromium, aluminum, copper, molybdenum and alloys thereof.

35. The display device of claim 21, wherein the first arrangement of polarity signals comprises an arrangement of (+)(-)(+)(-)(+)(-)(+)(-) polarity signals and the second arrangement of polarity signals comprises an arrangement of (+)(-)(+)(-)(-)(+)(-)(+) polarity signals.

36. The display device of claim 21, wherein the first arrangement of polarity signals comprises an arrangement of (-)(+)(-)(+)(-)(+)(-)(+) polarity signals and the second arrangement of polarity signals comprises an arrangement of (-)(+)(-)(+)(+)(-)(+)(-) polarity signals.

37. A display device comprising:

a plurality of main pixels, each of the plurality of main pixels including $2n$ sub-pixels, wherein n is an integer greater than one;

a plurality of gate lines disposed on a substrate, wherein the plurality of gate lines extends in a first direction;

a plurality of data lines crossing the plurality of gate lines; a transmission part which receives data signals and supplies the data signals to the plurality of data lines;

wherein the transmission part comprises:

a first transmission line which includes an opened portion disposed therein;

a first conductor disposed in the opened portion of the first transmission line; and

a second transmission line which extends through the opened portion of the first transmission line.

38. The display device of claim 37, wherein the transmission part further comprises:

14

a third transmission line which includes an opened portion disposed therein,

a fourth transmission line disposed substantially parallel to the third transmission line; and

a second conductor disposed in the opened portion in the third transmission line.

39. The display device of claim 37, wherein at least one of a shape and a material of the second conductor is selected such that electrical characteristics of the second conductor and the third transmission line together are substantially equal to electrical characteristics of the first conductor and the first transmission line together.

40. The display device of claim 39, wherein the electrical characteristics comprise a resistance.

41. The display device of claim 37, wherein the plurality of main pixels comprises a first main pixel connected to the first transmission part and a second main pixel connected to the second transmission part, and wherein a polarity of the first main pixel and a polarity of the second main pixel are symmetrically opposite to each other.

42. The display device of claim 41, wherein when the first main pixel has a polarity sequence of (+)(-)(+)(-), the second main pixel has a polarity sequence of (-)(+)(-)(+).

43. The display device of claim 42, wherein each main pixel includes four sub-pixels,

wherein each sub-pixel of the four sub-pixels of each main pixel comprises one of a first color, a second color, a third color, and a fourth color,

wherein each sub-pixel of the four sub-pixels of each main pixel has a different color, and

wherein the first color, the second color, the third color and the fourth color are different from one another.

44. The display device of claim 43, wherein the first transmission part and the second transmission part are repetitively arranged in the first direction with respect to each main pixel.

45. The display device of claim 44, wherein the first main pixel and the second main pixel are repetitively arranged in the first direction corresponding to the first transmission part and the second transmission part.

46. The display device of claim 45, wherein a first sub-pixel of the first main pixel has the first color and a first sub-pixel of the second main pixel has the first color, and

wherein a polarity of the first sub-pixel of the first main pixel and a polarity of the first sub-pixel of the second main pixel are different from each other.

47. The display device of claim 46, wherein each main pixel of the plurality of main pixels comprises four sub-pixels arranged in the first direction.

48. The display device of claim 37, wherein the first transmission line comprises a first terminal and a second terminal spaced apart from the first terminal by the opened portion, and

wherein the first conductor disposed in the opened portion of the first transmission line connects the first terminal and the second terminal.

49. The display device of claim 37, wherein the plurality of data lines comprise a multi-layered structure including at least two metal layers, and wherein at least two of the at least two metal layers have different physical properties from each other.

50. The display device of claim 49, wherein the plurality of data lines comprise at least one of chromium, aluminum, copper, molybdenum and alloys thereof.

51. The display device of claim 50, wherein the plurality of data lines comprise a multi-layered structure including at

least two metal layers, and wherein at least two of the at least two metal layers have different physical properties from each other.

52. The display device of claim 51, wherein the plurality of data lines comprise at least one of chromium, aluminum, copper, molybdenum and alloys thereof.

53. A display device comprising:

a plurality of main pixels, each of the plurality of main pixels including $2n$ sub-pixels, wherein n is an integer greater than one;

a plurality of gate lines disposed on a substrate, wherein the plurality of gate lines extends in a first direction;

a plurality of data lines crossing the plurality of gate lines;

a transmission part which receives data signals and supplies the data signals to the plurality of data lines;

wherein the transmission part comprises:

a first transmission part which comprises:

a first transmission line; and

a second transmission line which crosses the first transmission line, and

a second transmission part disposed adjacent to the first transmission part in the first direction, wherein the second transmission part comprises:

a third transmission line; and

wherein a width of the first transmission line is selected such that electrical characteristics of the first transmission line are substantially equal to electrical characteristics of the third transmission line.

54. The display device of claim 53, wherein the second transmission part further comprises:

a fourth transmission line disposed substantially parallel to the third transmission line,

wherein the first transmission line has a wider width than a width of the third transmission line and a wider width than the fourth transmission line.

55. The display device of claim 53, wherein the electrical characteristics comprise a resistance.

56. The display device of claim 53, wherein at least one of the plurality of data lines and the plurality of gate lines comprise a multi-layered structure including at least two metal layers, and wherein at least two of the at least two metal layers have different physical properties from each other.

57. The display device of claim 56, wherein at least one of the plurality of data lines and the plurality of the gate lines comprise at least one of chromium, aluminum, copper, molybdenum and alloys thereof.

58. A method of driving a display device including a plurality of main pixels, each main pixel of the plurality of main pixels having a plurality of $2n$ sub-pixels, wherein n is an integer greater than one, and a plurality of signal lines which extends in a first direction and is connected to the plurality of sub-pixels, the method comprising:

receiving first data signals from a data driver, wherein the first data signals are arranged in a first arrangement;

transforming the first data signals into second data signals having a second arrangement different than the first arrangement; and

transmitting the second data signals to the plurality of signal lines.

59. The method of driving a display device of claim 58, wherein the first data signals include a first data portion and a second data portion sequentially arranged in a second direction substantially perpendicular to the first direction,

wherein the second data signals include a third data portion and a fourth data portion sequentially arranged in the second direction, the third data portion and the

fourth data portion corresponding to the first data portion and the second data portion, respectively, wherein the third data portion includes data signals arranged in the first arrangement,

wherein the fourth data portion includes at least one pair of sequentially ordered data signals, and

wherein each data signal within the at least one pair of sequentially ordered data signals is transposed with respect to the second data portion of the first data signals.

60. The method of driving the display device of claim 59, wherein the third data portion of the second data signals includes only 2 data signals transmitted to a single main pixel of the plurality of main pixels.

61. The method of driving the display device of claim 59, wherein the third data portion of the second data signals includes $2n$ data signals transmitted to a single main pixel of the plurality of main pixels.

62. The method of driving the display device of claim 58, wherein the plurality of main pixels comprises a first main pixel connected to the first transmission part and a second main pixel connected to the second transmission part.

63. The method of driving the display device of claim 62, wherein a first sub-pixel of the first main pixel has a first color and a first sub-pixel of the second main pixel has the first color, and

wherein a polarity of the first sub-pixel of the first main pixel and a polarity of the first sub-pixel of the second main pixel are different from each other.

64. The method of driving the display device of claim 63, wherein each main pixel includes four sub-pixels, wherein each sub-pixel of the four sub-pixels of each main pixel comprises one of the first color, a second color, a third color, and a fourth color,

wherein each sub-pixel of the four sub-pixels of each main pixel has a different color, and wherein the first color, the second color, the third color and the fourth color are different from one another.

65. The method of driving the display device of claim 64, wherein each main pixel of the plurality of main pixels comprises four sub-pixels arranged in the first direction.

66. The method of driving the display device of claim 65, wherein a polarity sequence of sub-pixels in the first main pixel and the second main pixel comprises (+)(-)(+)(-)(-)(+)(-)(+) in a first frame.

67. The method of driving the display device of claim 66, wherein a polarity sequence of sub-pixels in the first main pixel and the second main pixel comprises (-)(+)(-)(+) (+)(-)(+)(-) in a frame which is subsequent to the first frame.

68. The method of driving the display device of claim 66, wherein the first transmission part comprises a first transmission line of the at least one pair of transmission lines which cross each other has an opened portion disposed therein, wherein the first transmission line further comprises a first conductor disposed in the opened portion.

69. The method of driving the display device of claim 68, wherein the first conductor comprises at least one of indium zinc oxide and indium tin oxide.

70. A display device comprising:

a plurality of main pixels, each main pixel of the plurality of main pixels having a plurality of $2n$ sub-pixels, wherein n is an integer greater than one;

a data driver which outputs a plurality of first data signals;

a plurality of signal lines which extends in a first direction and is connected to the plurality of main pixels; and

a transmission control member connected to the data driver, wherein the transmission control member

receives first data signals from the data driver, wherein the first data signals are arranged in a first arrangement, and transforms the first data signals into second data signals having a second arrangement which is different than the first arrangement, and transmits the second 5
data signals to the plurality of signal lines.

71. The display device of claim 70, wherein the first data signals include a first data portion and a second data portion sequentially arranged in a second direction substantially perpendicular to the first direction, 10

wherein the second data signals include a third data portion and a fourth data portion sequentially arranged in the second direction, the third data portion and the fourth data portion corresponding to the first data portion and the second data portion, respectively, 15

wherein the third data portion includes data signals arranged in the first arrangement,

wherein the fourth data portion includes at least one pair of sequentially ordered data signals, and

wherein each data signal within the at least one pair of 20
sequentially ordered data signals is transposed with respect to the second data portion of the first data signals.

* * * * *