



US00RE45484E

(19) **United States**
(12) **Reissued Patent**
Foley et al.

(10) **Patent Number:** **US RE45,484 E**
(45) **Date of Reissued Patent:** **Apr. 21, 2015**

(54) **IMAGE GUIDED AWL/TAP/SCREWDRIVER**
(75) Inventors: **Kevin T. Foley**, Germantown, TN (US);
Anthony J. Melkent, Germantown, TN
(US); **Catalina J. Carroll**, Memphis, TN
(US)

4,673,352 A 6/1987 Hansen 433/69
4,722,056 A 1/1988 Roberts et al. 364/413
4,836,778 A 6/1989 Baumrind et al. 433/69
5,050,608 A 9/1991 Watanabe et al. 128/653
5,078,140 A 1/1992 Kwoh 128/653.1

(Continued)

(73) Assignee: **Medtronic Navigation, Inc.**, Louisville,
CO (US)

FOREIGN PATENT DOCUMENTS

(21) Appl. No.: **13/453,709**

CA 1336451 1/1988
EP 0 326 768 12/1988

(Continued)

(22) Filed: **Apr. 23, 2012**

OTHER PUBLICATIONS

Related U.S. Patent Documents

Reissue of:

(64) Patent No.: **6,021,343**
Issued: **Feb. 1, 2000**
Appl. No.: **08/971,126**
Filed: **Nov. 20, 1997**

C. Hunter Shelden, M.D, et al., "Development of a computerized microstereotaxic method for localization and removal of minute CNS lesions under direct 3-D vision," J. Neurosurg 52: 21-27, 1980.

(Continued)

U.S. Applications:

(63) Continuation of application No. 10/062,265, filed on Jan. 31, 2002, now Pat. No. Re. 43,328, which is an application for the reissue of Pat. No. 6,021,343.

Primary Examiner — Mark Remaly

(74) *Attorney, Agent, or Firm* — Harness, Dickey

(51) **Int. Cl.**
A61B 5/05 (2006.01)
A61B 17/88 (2006.01)

(52) **U.S. Cl.**
CPC **A61B 17/8875** (2013.01)

(58) **Field of Classification Search**
USPC 600/407, 417, 429, 473, 476;
606/60-62, 79, 80, 96, 104, 130
See application file for complete search history.

(57) **ABSTRACT**

A trackable medical instrument for use in a computer assisted image guided medical and surgical navigation systems that generate images during medical and surgical procedures, includes a guide member having an emitter array for being tracked by the system and a drive shaft contained within the guide member having a proximal and a distal end, the drive shaft being rotatable within the guide member while being fixable axially inside the guide member, the proximal end of the drive shaft having a first connector for interchangeably receiving at least one drive source, and the distal end having a second connector for interchangeably receiving at least one instrument tip.

(56) **References Cited**

U.S. PATENT DOCUMENTS

3,963,028 A 6/1976 Cooley et al. 128/276
4,672,306 A 6/1987 Thong 324/72.5

28 Claims, 5 Drawing Sheets

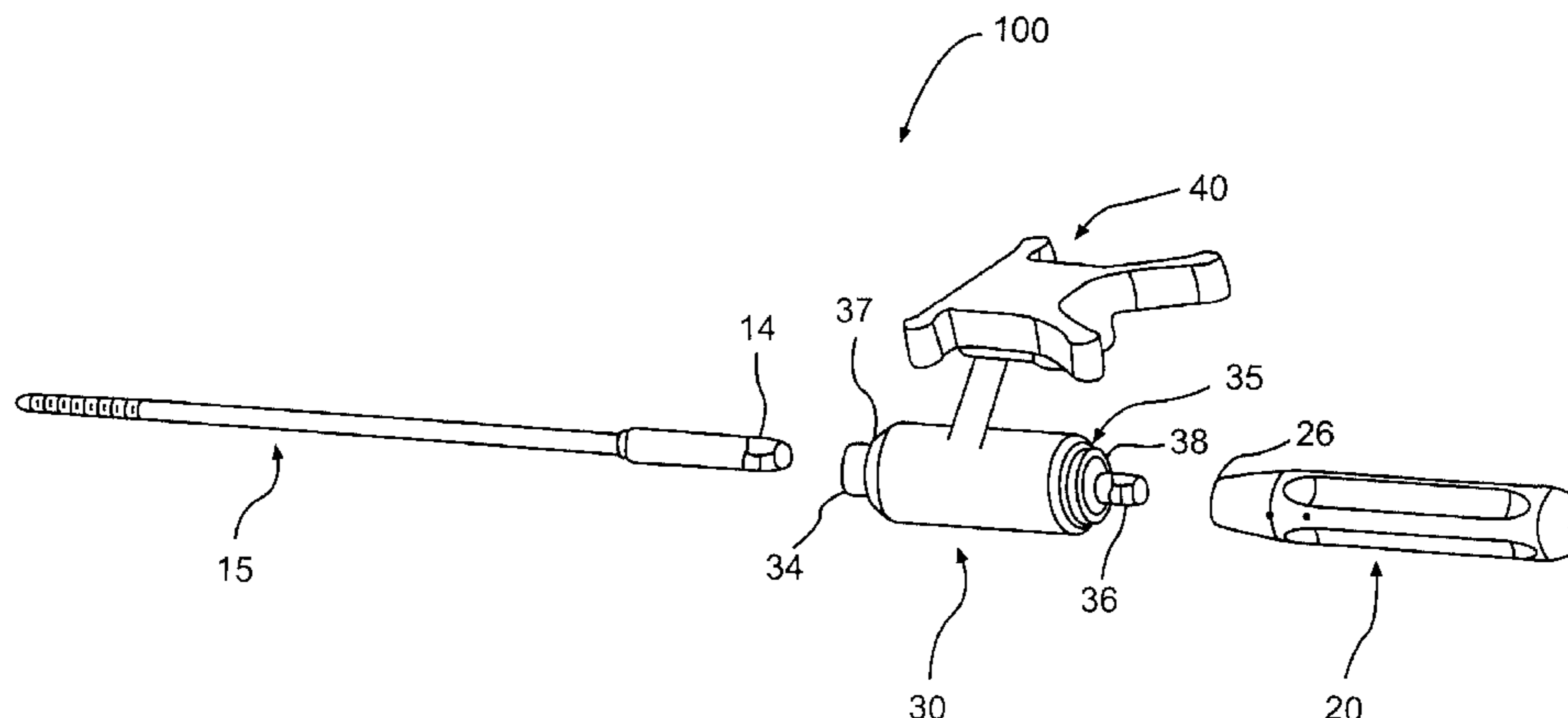

(56)

References Cited

U.S. PATENT DOCUMENTS

5,186,174	A	2/1993	Schlöndorff et al.	128/653
5,198,877	A	3/1993	Schulz	356/375
5,207,681	A	5/1993	Ghadjar et al.	606/96
5,230,623	A	7/1993	Guthrie et al.	433/72
5,251,127	A	10/1993	Raab	364/413
5,295,483	A	3/1994	Nowacki et al.	128/660.03
5,299,288	A	3/1994	Glassman et al.	395/80
5,305,203	A	4/1994	Raab	364/413
5,383,454	A	1/1995	Bucholz	128/653.1
5,389,101	A	2/1995	Heilbrun et al.	606/130
5,437,212	A	8/1995	Thompson et al.	81/63.1
5,447,154	A	9/1995	Cinquin et al.	128/653.1
5,474,558	A	12/1995	Neubardt	
5,517,990	A	5/1996	Kalfas et al.	128/653
5,564,437	A	10/1996	Bainville et al.	
5,575,192	A	11/1996	Eggert	81/63.1
5,383,454	B1	12/1996	Bucholz	128/653.1
5,591,207	A	1/1997	Coleman	
5,617,857	A	4/1997	Chader et al.	600/424
5,622,170	A	4/1997	Schulz	128/653
5,645,545	A	7/1997	Bryant	606/62
5,662,111	A	9/1997	Cosman	128/653.1
5,676,673	A	10/1997	Ferre et al.	606/130
5,682,890	A	11/1997	Kormos et al.	
D387,427	S	12/1997	Bucholz et al.	D24/140
5,732,703	A	3/1998	Kalfas et al.	600/407
5,772,594	A	6/1998	Barrick	
5,810,828	A	9/1998	Lightman et al.	
6,236,875	B1 *	5/2001	Bucholz et al.	600/407

FOREIGN PATENT DOCUMENTS

EP	0 501 993	B1	11/1990
EP	0 469 966	A1	7/1991
WO	WO 90/05494		5/1990
WO	WO 91/04711		4/1991
WO	WO 91/07726		5/1991
WO	WO 92/06645		4/1992
WO	WO 94/23647		10/1994
WO	WO 94/24933		11/1994
WO	WO 96/11624		4/1996
WO	WO97/15234		5/1997

OTHER PUBLICATIONS

M. Peter Heilbrun, M.D., "Computer Tomography—Guided Stereotactic Systems," *Computed Tomographic Stereotaxy*, Ch.31, pp. 564-581, 1983.

Richard D. Bucholz, M.D. and K. Charles Cheung, M.D., "Halo vest versus spinal fusion for cervical injury: evidence from an outcome study," *J. Neurosurg* 70:884-892, Jun. 1989.

W. Krybus, et al., "Navigation Support for Surgery by Means of Optical Position Detection," p. 362-366, 1990.

Kurt R. Smith and Richard D. Bucholz, "Computer Methods for Improved Diagnostic Image Display Applied to Stereotactic Neurosurgery," *Stereotactic Neurosurgery Display*, vol. 14, pp. 371-382, 1992.

L. Adams, et al., "Aide Au Reperage Tridimensionnel Pour La Chirurgie de la Base du Crane," *Innov. Tech. Biol. Med.*, vol. 13, No. 4, pp. 409-424, 1992.

Hans F. Reinharts, M.D., et al., "Sonic Stereometry in Microsurgical Procedures for Deep-Seated Brain Tumors and Vascular Malformations," *Neurosurgery*, vol. 32, No. 1, Jan. 1993, pp. 51-57.

Skip Jacques, et al., "A Computerized Microstereotactic Method to Approach, 3-Dimensionally Reconstruct, Remove and Adjuvantly Treat Small CNS Lesions," *Meeting of the Amer. Soc. Stereotactic & Functional Neurosurgery*, Houston 1980, *Appl. Neurophysiol.* 43: 176-182 (1980).

Richard D. Bucholz, M.D., and Kurt R. Smith, "A Comparison of Sonic Digitizers Versus Light Emitting Diode-Based Localization," *Interactive Image-Guided Neurosurgery*, pp. 179-200, 1993.

Richard D. Bucholz, et al., "Clinical Applications of Modern Imaging Technology," *SPIE* vol. 1894 pp. 312-322, Jan. 19, 1993.

Richard D. Bucholz, et al., "Intraoperative localization using a three dimensional optical digitizer," *Proceedings of Clinical Applications of Modern Imaging Technology*, vol. 1894, pp. 312-322, 1993.

Kevin T. Foley, et al., "Image-guided Intraoperative Spinal Localization," *Intraoperative Neuroprotection: Monitoring*, Ch. 19, pp. 325-340, 1996.

Kurt R. Smith, et al., "The Neurostation™—A Highly Accurate, Minimally Invasive Solution To Frameless Stereotactic Neurosurgery," *Computerized Medical Imaging and Graphics*, Jul.-Aug. 1994, vol. 18, No. 4, pp. 247-256.

Isabelle M. Germano, "The NeuroStation System for Image-Guided, Frameless Stereotaxy," *Neurosurgery*, vol. 37, No. 2, Aug. 1995, pp. 348-350.

Offset Probe for SAC GP8-3d Digitizer, 2 pages, not dated.

"Alignment Procedure for the PixSys Two-Emitter Offset Probe for the SAC GP-8-3d Sonic Digitizer," *PixSys*, Jul. 2, 1992, 4 pages.

"3-D Digitizing Accessories," *PixSys*, Jul. 2, 1992, 6 pages.

Richard D. Bucholz, M.D., et al., "Poster #1120, Use of an Intraoperative Optical Digitizer in a System for Free-Hand Stereotactic Surgery," *Scientific Program, Am. Assoc. of Neurological Surgeons 1992 Annual Meeting*, pp. 284-285, Apr. 16, 1992.

* cited by examiner

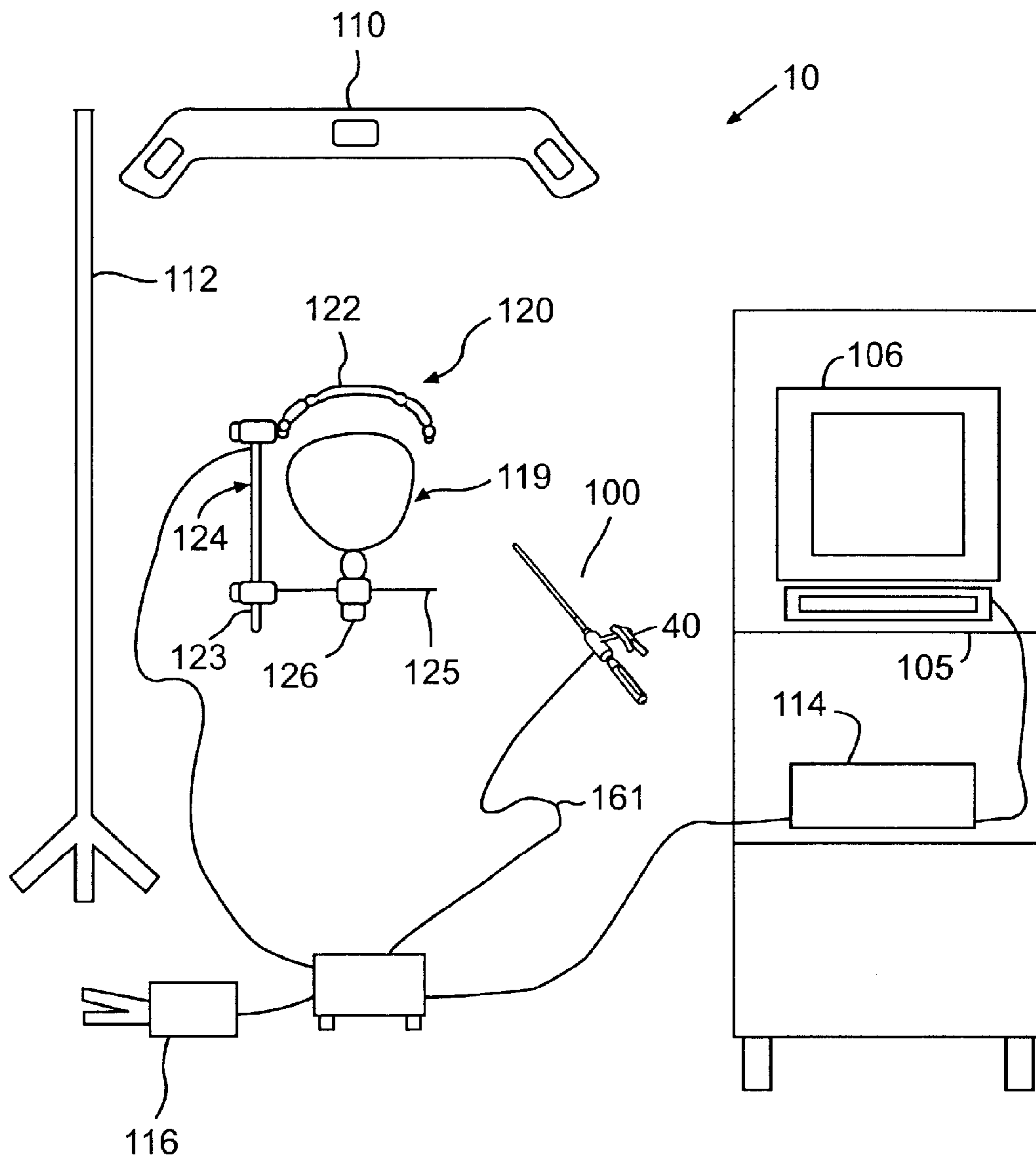

FIG. 1

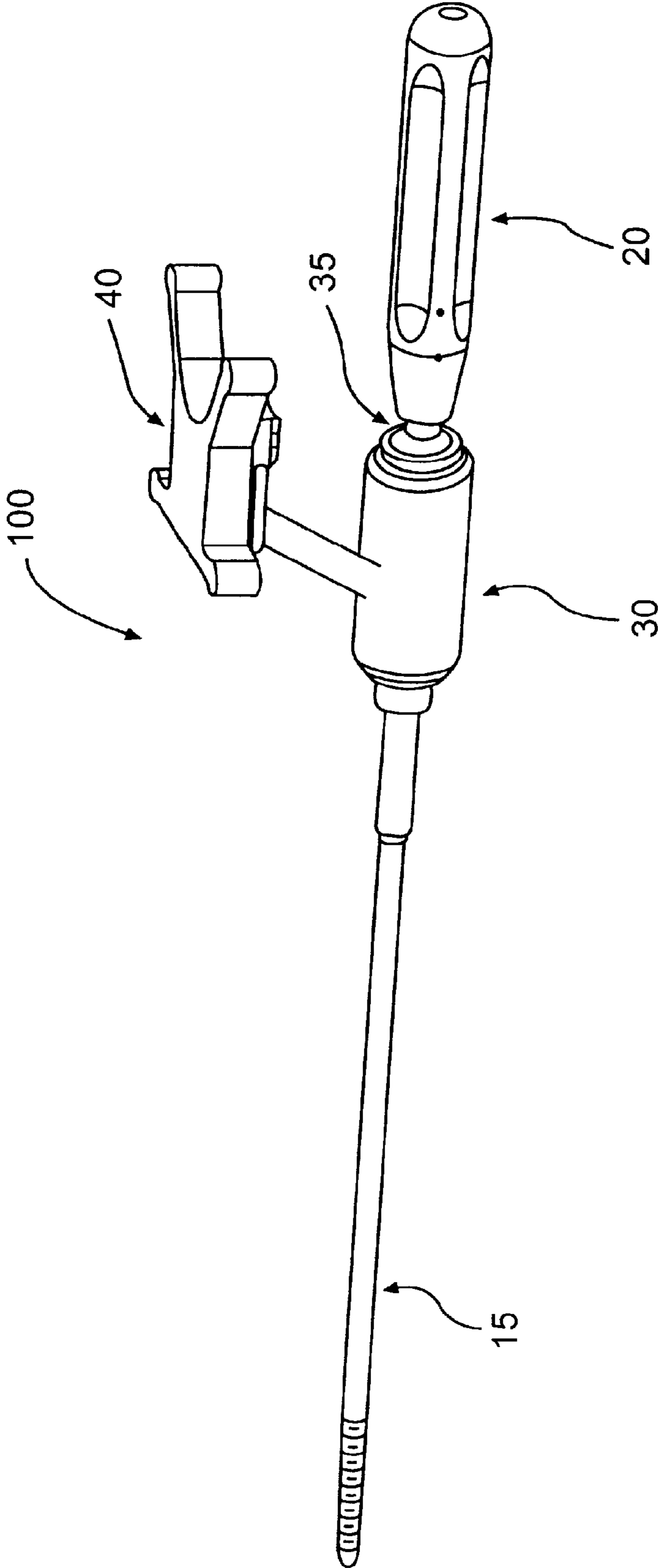

FIG. 2

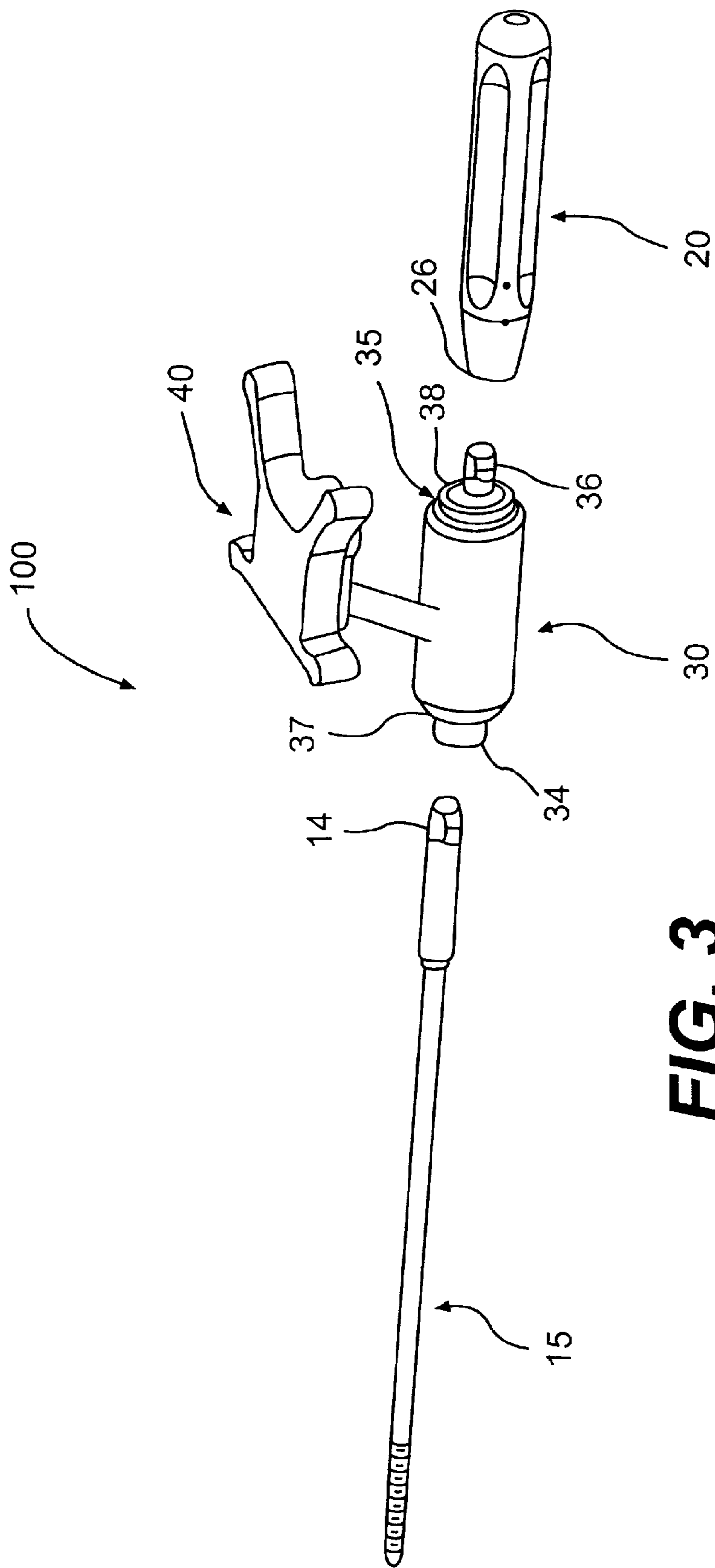

FIG. 3

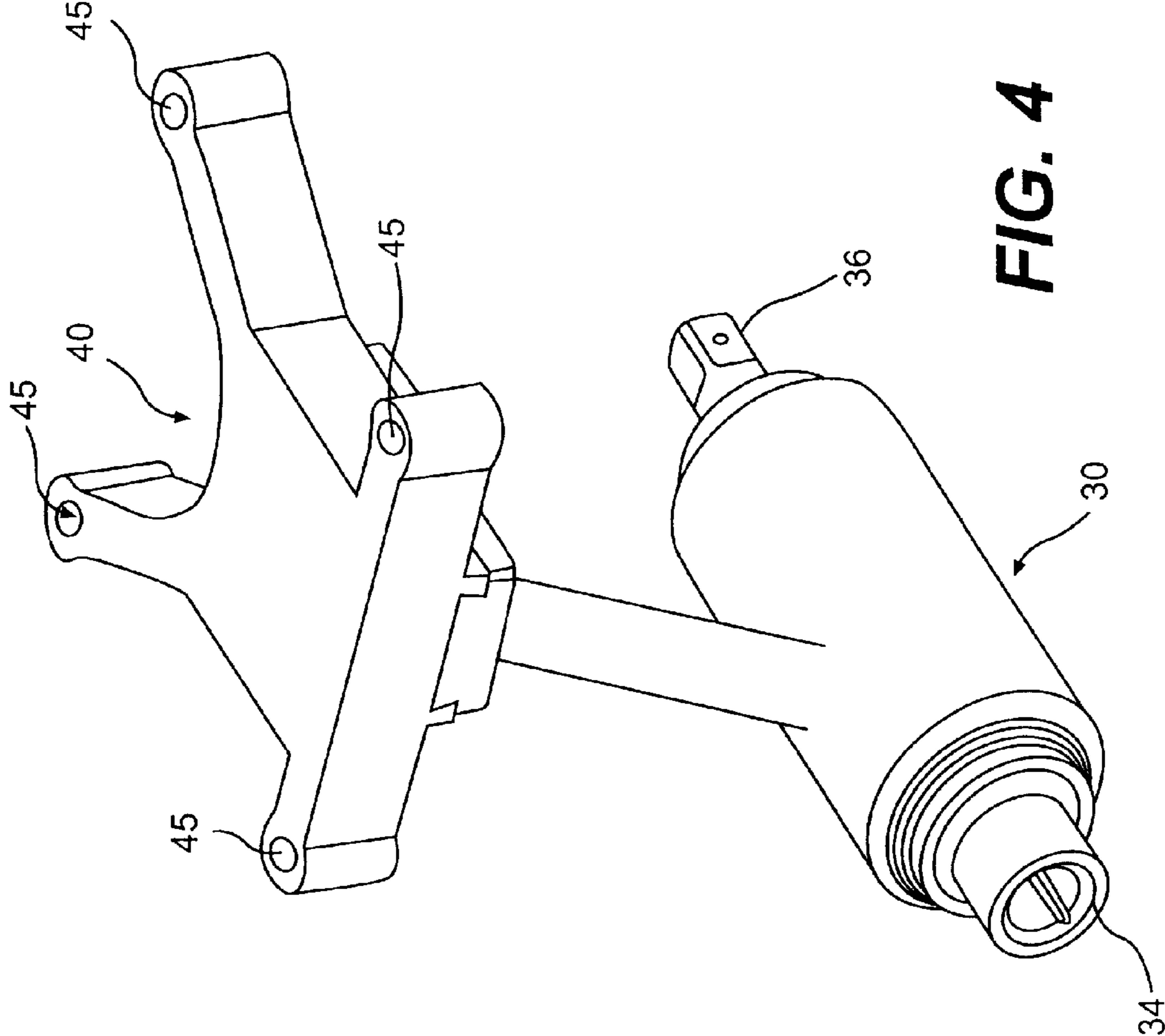

FIG. 4

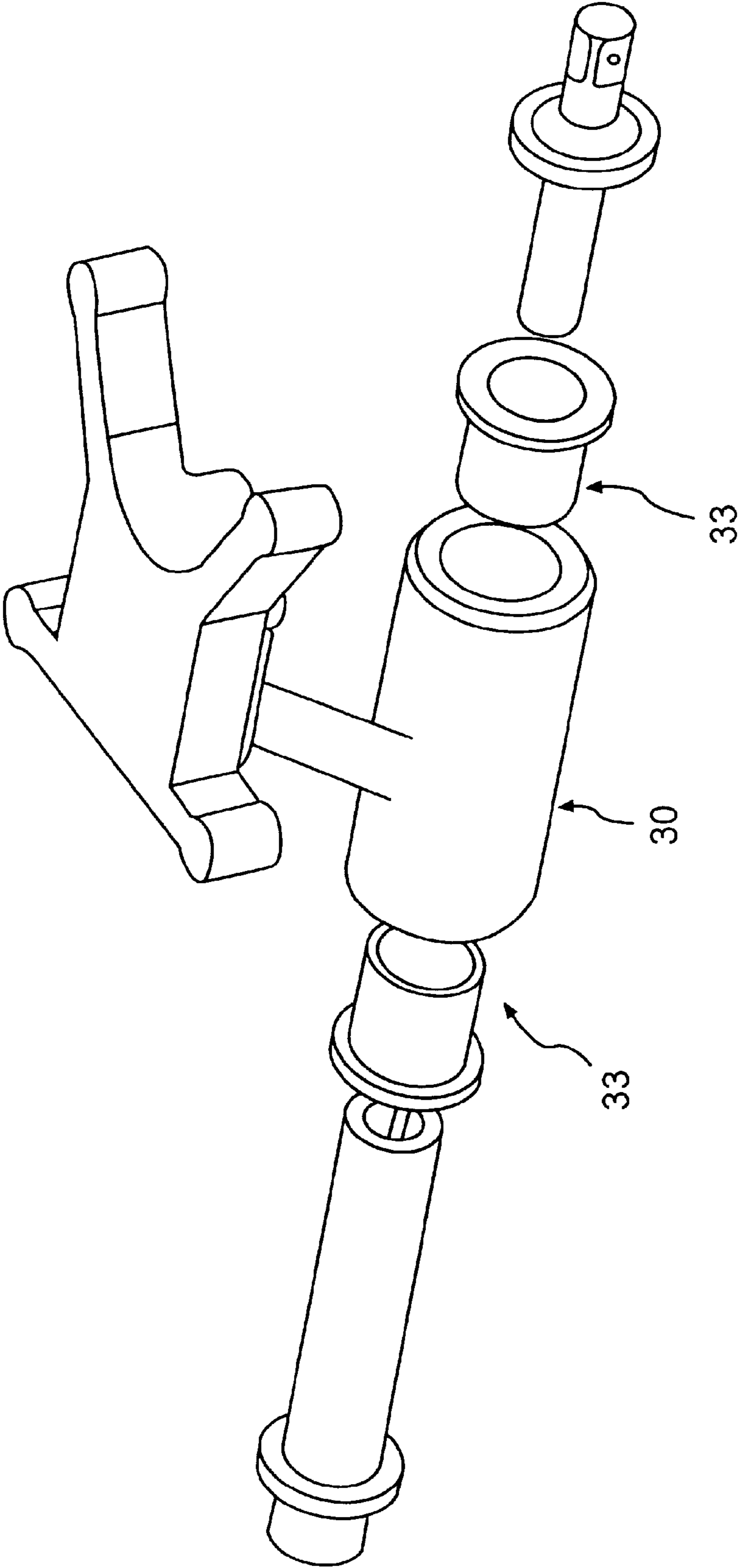

FIG. 5

IMAGE GUIDED AWL/TAP/SCREWDRIVER

Matter enclosed in heavy brackets [] appears in the original patent but forms no part of this reissue specification; matter printed in italics indicates the additions made by reissue; a claim printed with strikethrough indicates that the claim was canceled, disclaimed, or held invalid by a prior post-patent action or proceeding.

This application is a reissue of U.S. Pat. No. 6,021,343 issued on Feb. 1, 2000 and also claims benefit under 35 U.S.C. §120 as a continuation of issued U.S. Pat. No. Re. 43,328, filed on Jan. 31, 2002; which is also a reissue of U.S. Pat. No. 6,021,343 issued on Feb. 1, 2000. The disclosures of the above applications are incorporated herein by reference.

BACKGROUND OF THE INVENTION**1. Field of the Invention**

The present invention relates generally to computer assisted image guided medical and surgical navigation systems that generate images during medical and surgical procedures indicating the relative position of various body parts, surgical implants, and instruments. In particular, the present invention relates to an instrument for use in an image guided surgery navigation system that enables the system to track both the depth and the trajectory of the instrument during surgery.

2. Background of Related Art

Computer assisted image guided medical and surgical navigation systems are known and used to generate images in order to guide a doctor during a surgical procedure. Such systems are disclosed, for example, in U.S. Pat. No. 5,383,454 to Bucholz; PCT application Ser. No. PCT/US94/04530 (Publication No. WO 94/24933) to Bucholz; and PCT application Ser. No. PCT/US95/12984 (Publication No. WO 96/11624) to Bucholz et al., incorporated herein by reference.

In general, these image guided systems use images of a body part, such as CT scans, taken before surgery to generate images on a display, such as a CRT monitor screen, during surgery for representing the position of a surgical instrument with respect to the body part. The systems typically include tracking devices such as, for example, an LED array mounted on a surgical instrument as well as a body part, a digitizer to track in real time the position of the body part and the instrument used during surgery, and a monitor screen to display images representing the body and the position of the instrument relative to the body part as the surgical procedure is performed.

There is a need in the art for a surgically navigable tool for use with these image guided systems that is simple to use and manipulate, that enables the computer tracking system to track both the trajectory of the instrument and the depth that the instrument is inserted into the body, and that is easily interchangeable with alternative drive sources such as a ratcheting handle or other instruments such as awls, taps, and screwdrivers.

SUMMARY OF THE INVENTION

It is therefore an object of the invention to provide an image guided medical instrument whose tip and trajectory can be simultaneously tracked.

It is a further object of the invention to provide an image guided medical instrument capable of generating a signal representing the trajectory and the depth of the tip of the instrument.

It is a still further object of the invention to provide an image guided medical instrument that may easily be used with any number of different tips and handles.

It is another object of the invention to provide an image guided medical instrument that is of relatively simple construction and relatively easy to use.

Additional objects and advantages of the invention will be set forth in the description which follows and, in part, will be obvious from the description or may be learned by practice of the invention. The objects and advantages of the invention will be realized and attained by means of the elements and combinations particularly pointed out in the appended claims.

To achieve the objects and in accordance with the purpose of the invention, as embodied and broadly described herein, the invention comprises a trackable medical instrument for use in a computer assisted image guided surgery system having a digitizer for tracking the position of the instrument in three dimensional space and a display providing an indication of the position of the instrument with respect to images of a body part taken preoperatively. The instrument includes a guide member having an emitter array mounted thereon for being tracked by the digitizer, and a drive shaft contained within the guide member, the drive shaft having a proximal and a distal end, the drive shaft being rotatable within the guide member while being fixable axially within the guide member, the proximal end of the drive shaft having a first connector for interchangeably receiving at least one drive source, and the distal end having a second connector for interchangeably receiving at least one instrument tip. The instrument may further include at least one instrument tip for connection to the distal end of the drive shaft and a drive handle for connection to the proximal end of the drive shaft for transmitting torque to the instrument tip to cause rotation of the instrument tip.

In another aspect of this invention, the instrument may further include a sensor which senses the removal and the connection of an instrument tip to the instrument. The sensor may be an electromechanical switch on the guide member.

It is to be understood that both the foregoing general description and the following detailed description are exemplary and explanatory and are not restrictive of the invention as claimed.

BRIEF DESCRIPTION OF THE DRAWINGS

The accompanying drawings are included to provide a further understanding of the invention and are incorporated in and constitute a part of this specification. The drawings illustrate embodiments of the invention and, together with the description, serve to explain the principles of the invention.

FIG. 1 is a schematic front view of a computer assisted image guided surgery system used with an instrument according to the present invention.

FIG. 2 is a perspective view of an instrument according to the present invention.

FIG. 3 is an exploded view of the instrument shown in FIG. 2.

FIG. 4 is a view of a portion of the instrument shown in FIG. 2.

FIG. 5 is an exploded view of the portion of the instrument shown in FIG. 4.

DESCRIPTION OF THE PREFERRED EMBODIMENTS

Reference will now be made in detail to the present preferred embodiments of the invention, examples of which are illustrated in the accompanying drawings. Wherever possible, the same reference numbers are used in the drawings and the description to refer to the same or like parts.

The medical instrument of the present invention is shown generally at **10** in FIG. 1. Instrument **100** can be used in many known computer assisted image guided surgical navigation systems such the system shown in FIG. 1 and disclosed in PCT application Ser. No. PCT/US95/12984 (Publication No. WO 96/11624) to Buchholz et al., incorporated herein by reference. A computer assisted image guided surgery system, shown at **10**, generates an image for display on a monitor **106** representing the real time position of a body part and the position of instrument **100** relative to the body part.

An image may be generated on monitor **106** from an image data set stored in a controller, such as computer **108**, usually generated preoperatively by some scanning technique such as by a CAT scanner or by magnetic resonance imaging. The image data set and the image generated have reference points for at least one body part. The reference points for the particularly body part have a fixed spatial relation to the particular body part.

System **10** also generally includes a processor for processing image data, shown as digitizer control unit **114**. Digitizer control unit **114** is connected to monitor **106**, under control of computer **108**, and to instrument **100**. Digitizer **114**, in conjunction with a reference frame arc **120** and a sensor array **110** or other known position sensing unit, tracks the real time position of a body part, such as a cranium shown at **119** clamped in reference frame **120**, and an instrument **100**. Reference frame **120** has emitters **122** or other tracking means that generate signals representing the position of the various body reference points. Reference frame **120** is fixed spatially in relation to a body part by a clamp assembly indicated generally at **124, 125**, and **126**. Instrument **100** also has a tracking device shown as an emitter array **40** which generates signals representing the position of the instrument during the procedure.

Sensor array **110**, mounted on support **112**, receives and triangulates the signals generated by emitters **122** and emitter array **40** in order to identify during the procedure the relative position of each of the reference points and the instrument. Digitizer **114** and computer **108** may then modify the image data set according to the identified relative position of each of the reference points during the procedure. Computer **108** may then generate an image data set representing the position of the body elements and the instrument during the procedure. System **10** may also include a foot switch **116** connected to instrument **100** and digitizer **114** for controlling operation of the system. The structure and operation of an image guided surgery system is well known in the art and need not be discussed further here.

Referring to FIGS. 2 and 3, an instrument according to the present invention is shown at **100**. Instrument **100** includes a guide member **30**, an interchangeable instrument tip **15**, and an interchangeable driving handle **20**.

A drive shaft **35** is housed within guide member **30** and is removably connected to an end, here the proximal end **37**, to surgical instrument tip **15** and at the other end, here the distal end **38**, to driving handle **20** such that torque applied manu-

ally or by motorized means to drive handle **20** is transmitted to drive shaft **35** which in turn is transmitted to tip **15**. Drive shaft **35**, while it could be extractable such as for service, is fixable axially in relation to guide member **30**, but is rotatable within guide member **30**. As shown in FIG. 5, bushings **33** may be provided at each end of guide member **30** to ensure smooth motion between drive shaft **35** and guide member **30**. Guide member **30** is preferably made of stainless steel, but can also be made of titanium, aluminum or plastic. Shaft **35** is preferably made from stainless steel, titanium, or aluminum.

Instrument **100** further includes a tracking device such as emitter array **40** attached to guide member **30** for tracking the location and trajectory of instrument **100**. As shown in FIG. 4, array **40** is equipped with a plurality of emitters or tracking means **45**, preferably four emitters, for generating a signal representing the trajectory of instrument **100** and the depth of instrument tip **15**. Preferably emitters **45** are light emitting diodes; however, other tracking devices known in the art capable of being tracked by a corresponding sensor array are within the scope of the invention. For purposes of illustration, not limitation, the tracking device may generate signals actively such as with acoustic, magnetic, electromagnetic, radiologic, and micropulsed radar systems, or passively such as with reflective surfaces.

Drive handle **20** and instrument tip **15** are shown as modular units that can be attached to drive shaft **35** with corresponding and interlocking male and female socket joints. As shown in FIGS. 3 and 4, drive shaft **35** has a female socket joint **34** for connection with a male socket **14** on tip **15**, and drive shaft **35** has a male socket joint **36** for connection with a female socket joint **26** on drive handle **20**. With the use of male and female socket joints, various instrument tips and various type and sized drive handles can be easily interchangeable. Instrument tip **15** could be any of a variety of instruments used in surgery such as taps, awls, and shaped tools for interacting with a work piece, such as a screwdriver for driving screws. Drive handle **20** could be any number of existing or specially designed handles and could be ratcheting, nonratcheting or motorized. Instrument tip **15** and drive handle **20** could also be permanently attached to drive shaft **35**. Other suitable connection means are within the scope of the invention as well.

In operation, torque applied to drive handle **20** is transmitted through drive shaft **35** to instrument tip **15**. Because drive shaft **35** is fixed axially in relation to guide member **30**, guide member **30** can remain stationary while drive shaft **35** rotates without translating along the axis of drive shaft **35**. The relationship between array **40** and the axis of drive shaft **35**, therefore, remains constant. Instrument tip **15** is also fixed axially in relation guide member **30**. As a result, the relationship between array **40** and instrument tip **15** also remains constant. Because the relationship between array **40** and tip **15** is constant, the signals emitted by emitters **45** can be used by the computer assisted image guided surgical navigation system to inform the surgeon of the position of instrument **100**, indicating both the trajectory or orientation in three dimensional space of instrument **100** and the length of travel along the trajectory, i.e., the depth instrument tip **15** has been inserted into a body part.

It should be recognized that other variations or modifications may be made to provide an instrument that has an emitter array fixed axially relative to the instrument tip while allowing the instrument tip to rotate relative to the emitter array. For example, guide member **30** may also be integral with instrument tip **15** and/or drive handle **20**. The array could

5

then be fixed axially relative to the instrument and means could be provided to allow rotation of the instrument relative to the array.

As discussed above, a variety of different instrument tips may be easily interchanged on instrument 100. To use these different instrument tips, information concerning the dimensions of the different tips may be entered into computer 108. As a result, computer 108 can process the various image data for the specific instrument tip being used so that system 10 tracks the depth of the tip being used or, in the case of a screwdriver, so that system 10 tracks the depth of the screw being inserted.

System 10 may also be provided with a mechanism to prevent the system from operating after a new tip has been connected until computer 108 has been recalibrated. For example, an electromechanical switch, or other suitable sensors, could be provided on instrument 100 to provide a signal to computer 108 indicating that instrument tip 15 has been removed from instrument 100 or that a new instrument tip 15 has been coupled to instrument 100. The switch is preferably a micro switch but can be embodied by any suitable electrical or electromechanical device or sensing device capable of providing a signal in response to attachment or detachment at a particular point on guide member 30 or tip 15.

The switch may be automatically actuated when tip 15 is removed or coupled to instrument 100. Computer 108 may be operably connected to the switch, such as through cable 161, and is responsive to the operation of the switch. Alternatively, if a wireless instrument is used such as one with passive reflective surfaces in place of LED emitters, any suitable form of communication known in the art can be used. An alarm or other indication of some type, such as a message or display on monitor 106, may be generated by computer 108 indicating to the user that tip 15 has been changed. The computer 108 may further prevent the system from operating until the system has been recalibrated for the new instrument tip. Recalibration may be accomplished by touching the instrument tip to a known reference point. Recalibration of the instrument tip can be positively confirmed by means of a light emission from the emitter array 40 detected by sensor array 110 and triangulated to determine the position of the instrument tip. Alternatively, the dimensions of the instrument or tool type may be entered into computer 108 or selected from a pre-programmed list of tool dimensions or tool types. Further, recalibration could be accomplished by a fiber optic device for reading a bar code on the instrument tip, or by any other suitable recalibration technique.

It will also be apparent to those skilled in the art that various modifications and variations can be made to the structure and methodology of the present invention without departing from the scope or spirit of the invention. In view of the foregoing, it is intended that the present invention cover modifications and variations of this invention provided they fall within the scope of the following claims and their equivalents.

What is claimed is:

[1. A trackable medical instrument for use in a computer assisted image guided surgery system having a digitizer for tracking the position of the instrument in three dimensional space and a display providing an indication of the position of the instrument with respect to images of a body part take preoperatively, the instrument comprising:

a guide member having an emitter array mounted thereon for being tracked by a digitizer; and

a drive shaft contained within the guide member, the drive shaft having a longitudinal axis and a proximal and a distal end, the drive shaft being rotatable within the guide member while being fixable within the guide

6

member in a direction of the longitudinal axis, the proximal end of the drive shaft having a first connector for interchangeably receiving at least one drive source for transmitting torque to the drive shaft causing rotation of the drive shaft relative to the guide member, and the distal end having a second connector for interchangeably receiving at least one instrument tip.]

[2. The instrument according to claim 1, further comprising at least one instrument tip for removable connection to the distal end of the drive shaft.]

[3. The instrument according to claim 2, wherein the at least one drive source comprises a drive handle for removable connection to the proximal end of the drive shaft for transmitting torque to the drive shaft and the instrument tip to cause rotation of the instrument tip.]

[4. The instrument according to claim 3, wherein the drive handle and the drive shaft include a male-female socket joint to removably connect the drive shaft to the drive handle.]

[5. The instrument according to claim 3, wherein the drive handle includes a ratchet.]

[6. The instrument according to claim 3, wherein the drive handle includes a motor for imparting torque to the drive shaft.]

[7. The instrument according to claim 2, wherein the instrument tip and the drive shaft include a male-female socket joint to removably connect the drive shaft to the instrument tip.]

[8. The instrument according to claim 2, wherein the instrument tip is an awl.]

[9. The instrument according to claim 2, wherein the instrument tip is a tap.]

[10. The instrument according to claim 2, wherein the instrument tip has a shaped end for mating with a workpiece to be rotated by said drive shaft.]

[11. The instrument according to claim 2, wherein the instrument tip is a drill bit.]

[12. The instrument according to claim 1, wherein the emitter array includes at least one LED array for emitting light signals.]

[13. The instrument according to claim 12, wherein the LED array includes a base and a plurality of LED emitters disposed on the base.]

[14. The instrument according to claim 1, wherein at least one bushing is provided in the guide member to reduce friction between the guide member and drive shaft.]

[15. The instrument according to claim 1, wherein the instrument includes a sensor which senses the removal and connection of an instrument tip to the instrument.]

[16. The instrument according to 15, wherein the sensor includes an electromechanical switch on the guide member electrically connected to the system.]

[17. A trackable medical instrument for use in a computer assisted image guided surgery system having a digitizer for receiving signals representing a position of the instrument during surgery, a computer for processing the signals received, and a display for providing an image representing the position of the instrument in three dimensional space during surgery, the instrument comprising:

guiding means for guiding the instrument in three dimensional space, the guiding means including signaling means for providing a signal representing the trajectory of the instrument and the location of the instrument; and driving means for driving the instrument contained within the guiding means, the driving means having a longitudinal axis and being fixable in relation to the guiding means in a direction of the longitudinal axis while being rotatable in relation to the guiding means, the driving means having a first end adapted to interchangeably

receive at least one medical instrument tip and an opposite end adapted to interchangeably receive at least one drive source.]

[18. The instrument according to claim 17, wherein the instrument includes a sensing means for sensing the removal and the connection of an instrument tip to the instrument.]

[19. The instrument according to 18, wherein the sensing means includes an electromechanical switch on the guiding means connected to the means for processing.]

[20. The instrument according to claim 17, wherein the guiding means comprises a housing for receiving the driving means, the driving means being rotatable within the housing while being retained axially within the housing.]

[21. The instrument according to claim 20 wherein the signaling means comprises an LED array.]

[22. The instrument according to claim 21, further comprising an instrument tip for connection to the first end of the driving means.]

[23. The instrument according to claim 22, further comprising a drive handle for connection to the opposite end of the driving means for transmitting torque to the instrument tip to cause rotation of the instrument tip.]

[24. The instrument according to claim 20, wherein the driving means comprises a drive shaft having mating connectors on both ends for connection to corresponding connectors disposed on an instrument tip and a drive source.]

[25. The instrument according to claim 24, wherein at least one bushing is provided between the housing and the drive shaft to reduce friction between the guide handle and drive shaft.]

[26. The instrument according to claim 22, wherein the instrument tip is an awl.]

[27. The instrument according to claim 22, wherein the instrument tip is a tap.]

[28. The instrument according to claim 22, wherein the instrument tip has a shaped end for mating with a workpiece.]

[29. A trackable medical instrument for use in a computer assisted image guided surgery system having a digitizer for tracking the position of the instrument in three dimensional space and a display providing an indication of the position of the instrument with respect to images of a body part taken preoperatively, the instrument comprising:

a guide member having an emitter array mounted thereon for being tracked by a digitizer;

a drive shaft contained within the guide member, the drive shaft having a longitudinal axis and a proximal and a distal end, the drive shaft being rotatable within the guide member while being fixable within the guide member in a direction of the longitudinal axis;

an instrument tip extending from the proximal end of the drive shaft; wherein the instrument tip rotates freely relative to the guide member while being fixable axially relative to the guide member; and

a drive handle extending from the distal end of the drive shaft for guiding the instrument, including the guide member, and for imparting rotary motion to the drive shaft and the instrument tip independent of the guide member.]

[30. The instrument according to claim 29, further comprising a proximal coupler for interchangeably coupling the drive source to the drive shaft.]

[31. The instrument according to claim 30, wherein the proximal coupler comprises a male-female socket joint disposed on the drive shaft and the drive source to removably connect the drive source to the drive shaft.]

[32. The instrument according to claim 29, wherein the drive handle includes a ratchet.]

[33. The instrument according to claim 29, wherein the drive handle includes a motor for imparting rotary motion to the drive shaft.]

[34. The instrument according to claim 29, further comprising a distal coupler for interchangeably coupling the instrument tip to the drive shaft.]

[35. The instrument according to claim 34, wherein the distal coupler includes a male-female socket joint disposed on the drive shaft and the instrument tip to removably connect the instrument tip to the drive shaft.]

[36. The instrument according to claim 29, wherein the instrument tip is an awl.]

[37. The instrument according to claim 29, wherein the instrument tip is a tap.]

[38. The instrument according to claim 29, wherein the instrument tip has a shaped end for mating with a workpiece to be rotated by said drive shaft.]

[39. The instrument according to claim 29, wherein the instrument tip is a drill bit.]

[40. The instrument according to claim 29, wherein the emitter array includes at least one LED array for emitting light signals.]

[41. The instrument according to claim 29, wherein the at least one LED array includes a base and a plurality of LED emitters disposed on the base.]

[42. The instrument according to claim 29, wherein at least one bushing is provided in the guide member to reduce friction between the guide member and drive shaft.]

[43. A trackable medical instrument for use in a computer assisted image guided surgery system having a digitizer for tracking the position of the instrument in three dimensional space and a display providing an indication of the position of the instrument with respect to images of a body part taken preoperatively, the instrument comprising:

a guide member having a tracking device mounted thereon for being tracked by a digitizer;

a drive shaft contained within the guide member, the drive shaft having a longitudinal axis and a proximal and a distal end, the drive shaft being rotatable within the guide member while being fixable within the guide member in a direction of the longitudinal axis;

an instrument tip extending from the proximal end of the drive shaft; wherein the instrument tip rotates freely relative to the guide member while being fixable axially relative to the guide member; and

a drive handle extending from the distal end of the drive shaft for guiding the instrument, including the guide member, and for imparting rotary motion to the drive shaft and the instrument tip independent of the guide member.]

[44. The instrument according to claim 43, wherein the tracking device includes a passive signal generator.]

[45. The instrument according to claim 44, wherein the instrument comprises at least one reflective surface for reflecting signals to be tracked by the digitizer.]

[46. The instrument according to claim 44, wherein the instrument comprises at least three reflective surfaces for reflecting signals to be tracked by the digitizer.]

[47. The instrument according to claim 43, further comprising a proximal coupler for interchangeably coupling the drive source to the drive shaft.]

[48. The instrument according to claim 47, wherein the proximal coupler comprises a male-female socket joint disposed on the drive shaft and the drive source to removably connect the drive source to the drive shaft.]

[49. The instrument according to claim 43, further comprising a distal coupler for interchangeably coupling the instrument tip to the drive shaft.]

[50. The instrument according to claim 49, wherein the distal coupler includes a male-female socket joint disposed on the drive shaft and the instrument tip to removably connect the instrument tip to the drive shaft.]

51. A trackable medical instrument system, comprising:
a guide member having a tracking device mounted thereon
for being tracked; and

a surgical implement extending from the guide member, the surgical implement having a longitudinal axis and a proximal end and a distal end, the surgical implement being rotatable relative to the guide member while being fixable relative to the guide member in a direction of the longitudinal axis, and the distal end having at least one instrument tip;

wherein the surgical implement is configured to be rotated by at least one drive source transmitting torque to the surgical implement for causing rotation of the surgical implement relative to the guide member.

52. The instrument system of claim 51, further comprising:
a display for illustrating an indication of the position of the surgical implement with respect to images of a body part taken preoperatively;

wherein a digitizer is used for tracking the position of the surgical implement in three dimensional space to be displayed on the display.

53. The instrument system of claim 51, wherein the medical instrument system is recalibrated without touching the at least one instrument tip to a known reference point.

54. The instrument system of claim 51, wherein the medical instrument system is recalibrated by entering dimensions of the at least one instrument tip into a computer associated with a digitizer.

55. The instrument system of claim 51, wherein the medical instrument system is recalibrated by entering a tool-type of the at least one instrument tip into a computer associated with a digitizer.

56. The instrument system of claim 51, wherein the medical instrument system is recalibrated by selecting dimensions of the at least one instrument tip from a list of tool dimensions pre-programmed into a computer associated with a digitizer.

57. The instrument system of claim 51, wherein the medical instrument system is recalibrated by selecting a tool type of the at least one instrument tip from a list of tool types pre-programmed into a computer associated with a digitizer.

58. The instrument system of claim 51, further comprising:
a fiber optic device for reading a reference provided on the surgical implement;

wherein the medical instrument system is recalibrated based on information provided by the reference.

59. The instrument system of claim 51, further comprising:
a drive source extending from the distal end of the surgical implement configured to impart rotary motion to the at least one instrument tip independent of the guide member;

wherein the at least one instrument tip rotates freely relative to the guide member while being fixable axially relative to the guide member;

wherein after the medical instrument system is calibrated, the medical instrument system is recalibrated without touching the at least one instrument tip to a known reference point.

60. A trackable medical instrument system for use in a computer assisted image guided surgery system, comprising:

a guide member having a tracking device mounted thereon for being tracked; and

a drive shaft contained within the guide member, the drive shaft having a longitudinal axis, a first end and a second end, the drive shaft being rotatable within the guide member while being fixable within the guide member along the longitudinal axis, the first end of the drive shaft having a first connector for receiving at least one drive source for transmitting torque to the drive shaft for causing rotation of the drive shaft relative to the guide member, and the second end having at least one instrument tip extending therefrom.

61. The instrument system of claim 60, further comprising:
a drive handle as the drive source.

62. The instrument system of claim 60, wherein at least the drive shaft and the at least one instrument tip are permanently attached.

63. The instrument system of claim 60, wherein at least the drive shaft and the at least one drive source are permanently attached.

64. The instrument system of claim 60, wherein all of the drive shaft, the at least one instrument tip, and the at least one drive source are permanently attached.

65. The instrument system of claim 60, wherein the drive shaft is extractable from the guide member.

66. The instrument system of claim 65, further comprising:
bushings between the drive shaft and the guide member to allow smooth operation of the drive shaft.

67. The instrument system of claim 60, further comprising:
a computer where information regarding dimensions of the at least one instrument tip is entered into the computer.

68. The instrument system of claim 60, wherein the tracking device is configured to allow determination of both position and trajectory information in three dimensional space.

69. The instrument system of claim 60, wherein the at least one instrument tip is at least one of a tap, an awl, a shaped tool, or a screw driver.

70. The instrument system of claim 60, further comprising:
a monitor to display images;

a reference arc connected to a patient; and

a digitizer to triangulate the position of at least one of the tracking device or the reference arc.

71. A trackable medical instrument system for use in a computer assisted image guided surgery system, comprising:

a guide member integral with at least one instrument tip;
a tracking device connected to the guide member for being tracked; and

a drive shaft contained within the guide member, the drive shaft having a longitudinal axis and at least a first end; wherein the drive shaft is rotatable within the guide member while being fixable within the guide member along the longitudinal axis;

wherein the first end of the drive shaft has a first connector for receiving at least one drive source for transmitting torque to the drive shaft for causing rotation of the drive shaft relative to the guide member.

72. The instrument system of claim 71, wherein the tracking device is configured to rotate relative to the at least one instrument tip.

73. The instrument system of claim 71, wherein the guide member and the drive source are integral.

74. The instrument system of claim 71, further comprising:
a computer where information regarding dimensions of the at least one instrument tip is entered into the computer.

75. The instrument system of claim 71, wherein the tracking device is configured to allow determination of both position and trajectory information in three dimensional space.

76. The instrument system of claim 71, wherein the at least one instrument tip is at least one of a tap, an awl, a shaped tool, or a screw driver.

77. The instrument system of claim 71, further comprising:
 a monitor to display images; 5
 a reference arc connected to a patient; and
 a digitizer to triangulate the position of at least one of the tracking device or the reference arc.

78. A trackable medical instrument for use in a computer assisted image guided surgery system having a digitizer for tracking the position of the instrument in three dimensional space and a display providing an indication of the position of the instrument with respect to images of a body part taken preoperatively, the instrument comprising:

a guide member having a tracking device mounted thereon 15
 for being tracked by a digitizer; and

a drive shaft contained within the guide member, the drive shaft having a longitudinal axis and a proximal and a distal end, the drive shaft being rotatable within the guide member while being fixable within the guide member in a direction of the longitudinal axis, the proximal end of the drive shaft having a first connector for interchangeably receiving at least one drive source for transmitting torque to the drive shaft causing rotation of the drive shaft relative to the guide member, and the distal 20
 end having a second connector for interchangeably receiving at least one instrument tip. 25

* * * * *

UNITED STATES PATENT AND TRADEMARK OFFICE
CERTIFICATE OF CORRECTION

PATENT NO. : RE45,484 E
APPLICATION NO. : 13/453709
DATED : April 21, 2015
INVENTOR(S) : Foley et al.

Page 1 of 1

It is certified that error appears in the above-identified patent and that said Letters Patent is hereby corrected as shown below:

In the Specification

Please insert at Line 10 (approx.) in Column 1 as follows:

--Notice: More than one reissue application has been filed for the reissue of U.S. Patent No. 6,021,343. The reissue applications are U.S. Reissue Patent Application Serial No. 14/691,159, filed on April 20, 2015, now U.S. Reissue Patent No. RE46,409 E, issued May 23, 2017, and U.S. Reissue Patent Application Serial No. 14/545,311, filed on April 20, 2015, now U.S. Reissue Patent No. RE46,422 E, issued June 6, 2017, each of which are a continuation reissue application of U.S. Reissue Patent Application Serial No. 13/453,709 (the present application), filed on April 23, 2012, now U.S. Reissue Patent No. RE45,484 E, issued April 21, 2015, which is a continuation reissue application of U.S. Reissue Patent Application Serial No. 10/062,265, filed on January 31, 2002, now U.S. Reissue Patent No. RE43,328 E, issued April 24, 2012.--

Signed and Sealed this
Fifth Day of June, 2018

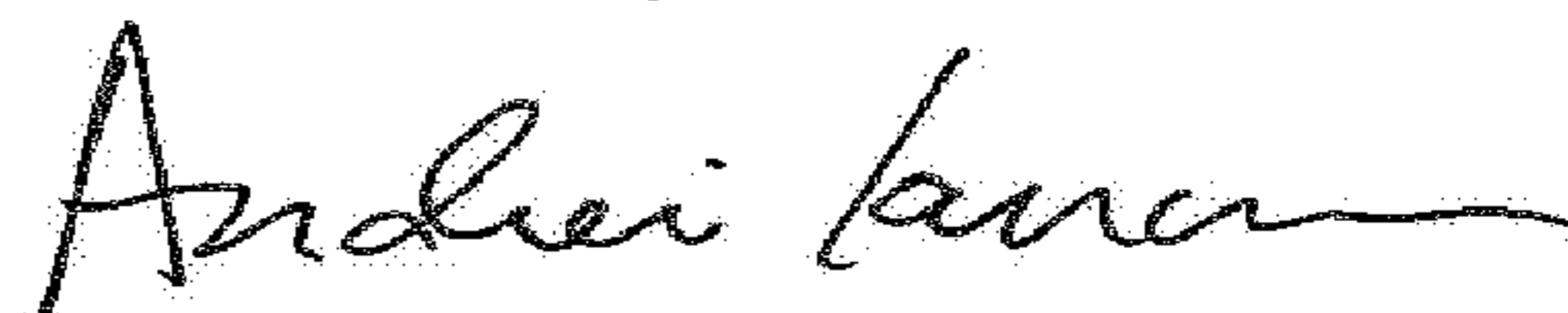

Andrei Iancu
Director of the United States Patent and Trademark Office

UNITED STATES PATENT AND TRADEMARK OFFICE
CERTIFICATE OF CORRECTION

PATENT NO. : RE45,484 E
APPLICATION NO. : 13/453709
DATED : April 21, 2015
INVENTOR(S) : Foley et al.

Page 1 of 1

It is certified that error appears in the above-identified patent and that said Letters Patent is hereby corrected as shown below:

In the Specification

At Column 1, replace Lines 12-16 (approx.), with the following:

--CROSS-REFERENCE TO RELATED APPLICATIONS

NOTICE: More than one reissue application has been filed for the reissue of U.S. Patent No. 6,021,343 A. The reissue applications are U.S. Reissue Patent Application Serial No. 14/691,954, filed on April 21, 2015, now abandoned, U.S. Reissue Patent Application Serial No. 14/691,159, filed on April 20, 2015, now U.S. Reissue Patent No. RE46,409 E, issued May 23, 2017, and U.S. Reissue Patent Application Serial No. 14/545,311, filed on April 20, 2015, now U.S. Reissue Patent No. RE46,422 E, issued June 6, 2017, each of which are a continuation reissue application of U.S. Reissue Patent Application Serial No. 13/453,709 (the present application), filed on April 23, 2012, now U.S. Reissue Patent No. RE45,484 E, issued April 21, 2015, which is a continuation reissue application of U.S. Reissue Patent Application Serial No. 10/062,265, filed on January 31, 2002, now U.S. Reissue Patent No. RE43,328 E, issued April 24, 2012, which is a reissue application of 08/971,126, filed on November 20, 1997, now U.S. Patent No. 6,021,343 A, issued February 1, 2000. The disclosures of the--

This certificate supersedes the Certificate of Correction issued June 5, 2018.

Signed and Sealed this
Twelfth Day of January, 2021

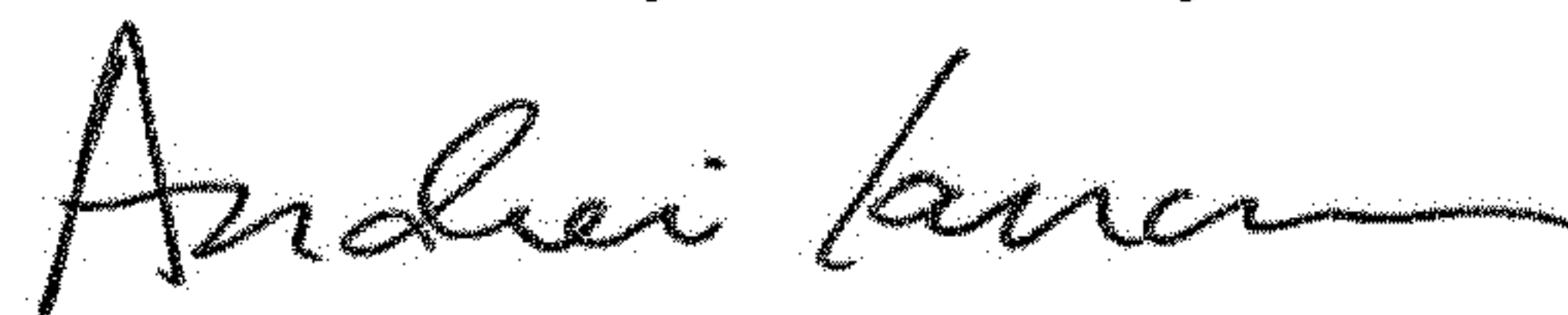

Andrei Iancu
Director of the United States Patent and Trademark Office