



US00RE45296E

(19) **United States**
(12) **Reissued Patent**
Kyu

(10) **Patent Number:** **US RE45,296 E**
(45) **Date of Reissued Patent:** **Dec. 23, 2014**

(54) **FRAME FOR A BICYCLE**
(75) Inventor: **Song Joon Kyu**, Kyungki-Do (KR)
(73) Assignee: **Mando Corporation**, Gyeonggi-Do (KR)
(21) Appl. No.: **29/412,583**
(22) Filed: **Feb. 6, 2012**

Primary Examiner — Philip S Hyder
(74) *Attorney, Agent, or Firm* — McDermott Will & Emery LLP

(57) **CLAIM**
The ornamental design for a frame for a bicycle, as shown and described.

Related U.S. Patent Documents

Reissue of:
(64) Patent No.: **Des. 643,785**
Issued: **Aug. 23, 2011**
Appl. No.: **29/379,863**
Filed: **Nov. 24, 2010**

DESCRIPTION

FIG. 1 is a front/right-side/top perspective view of a frame for a bicycle showing the new design;
FIG. 2 is a front-side elevational view thereof;
FIG. 3 is a rear-side elevational view thereof;
FIG. 4 is a left-side elevational view thereof;
FIG. 5 is a right-side elevational view thereof;
FIG. 6 is a top-side elevational view thereof; and
FIG. 7 is a bottom-side elevational view thereof.
FIG. 8 is a front/right-side/top perspective view of the frame for a bicycle in a folded configuration;
FIG. 9 is a front-side elevational view thereof;
FIG. 10 is a rear-side elevational view thereof;
FIG. 11 is a left-side elevational view thereof;
FIG. 12 is a right-side elevational view thereof;
FIG. 13 is a top-side elevational view thereof;
FIG. 14 is a bottom-side elevational view thereof; and,
FIG. 15 illustrates is a front/right-side/top perspective view of the claimed frame for a bicycle, with environmental structure illustrated in broken lines that forms no part of the claimed design.

(30) **Foreign Application Priority Data**
May 26, 2010 (KR) 30-2010-0023267
(51) **LOC (10) Cl.** **12-11**
(52) **U.S. Cl.**
USPC **D12/111**
(58) **Field of Classification Search**
USPC D12/111, 117, 119; 280/274–280,
280/281.1, 283–288, 288.1–288.4
See application file for complete search history.

(56) **References Cited**
U.S. PATENT DOCUMENTS
6,032,971 A * 3/2000 Herder 280/278
6,267,401 B1 * 7/2001 De Jong 280/287
6,688,625 B1 * 2/2004 Schreuder et al. 280/260
D487,234 S * 3/2004 Chen et al. D12/111
6,764,090 B1 * 7/2004 Pan 280/278
D494,508 S * 8/2004 Liu D12/111
D497,574 S * 10/2004 Yamabe D12/111
D547,702 S * 7/2007 Tabuchi et al. D12/111

* cited by examiner

1 Claim, 15 Drawing Sheets

Matter enclosed in heavy brackets [] appears in the original patent but forms no part of this reissue; matter printed in italics indicates the additions made by reissue.

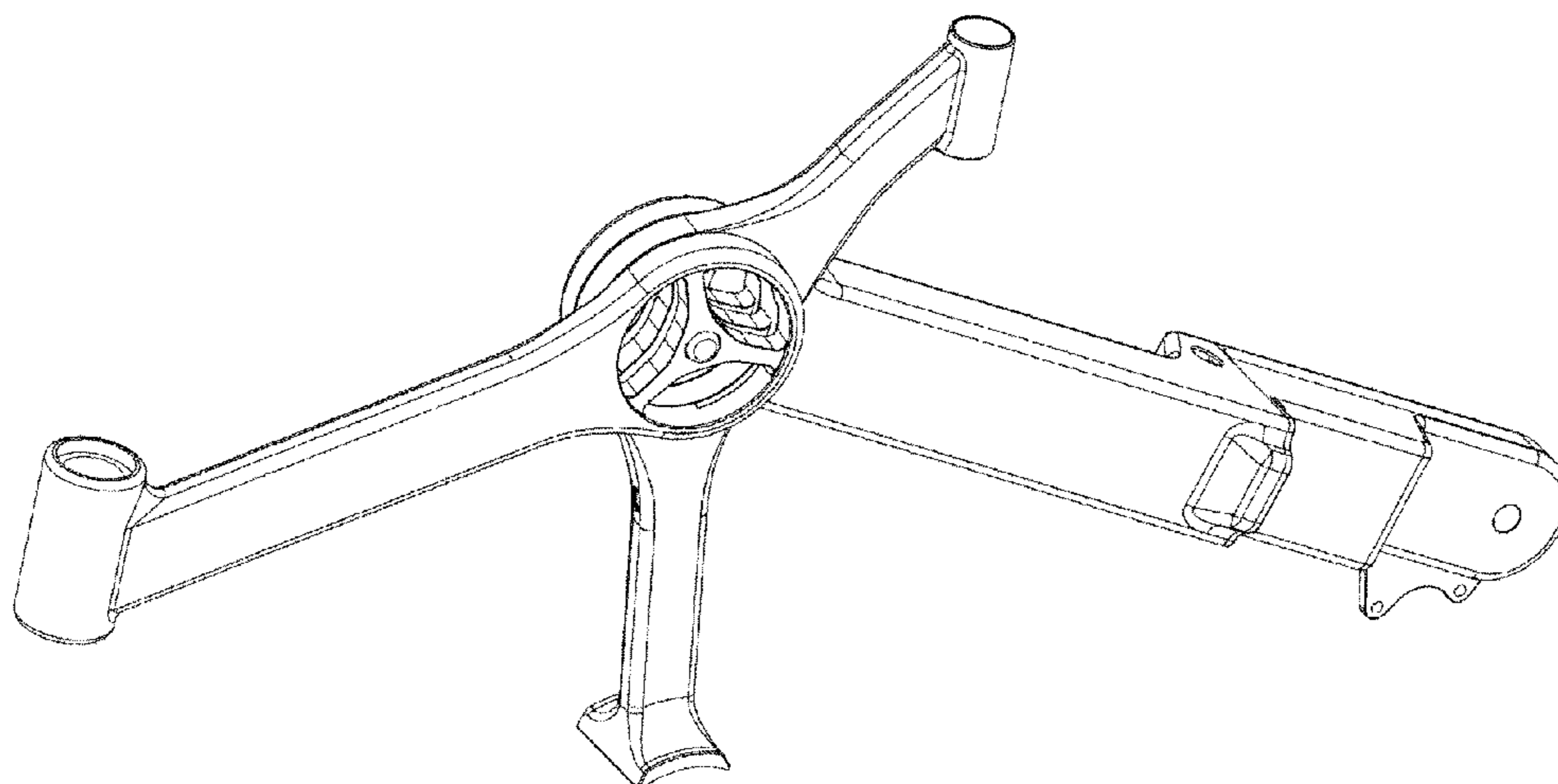

Fig. 1

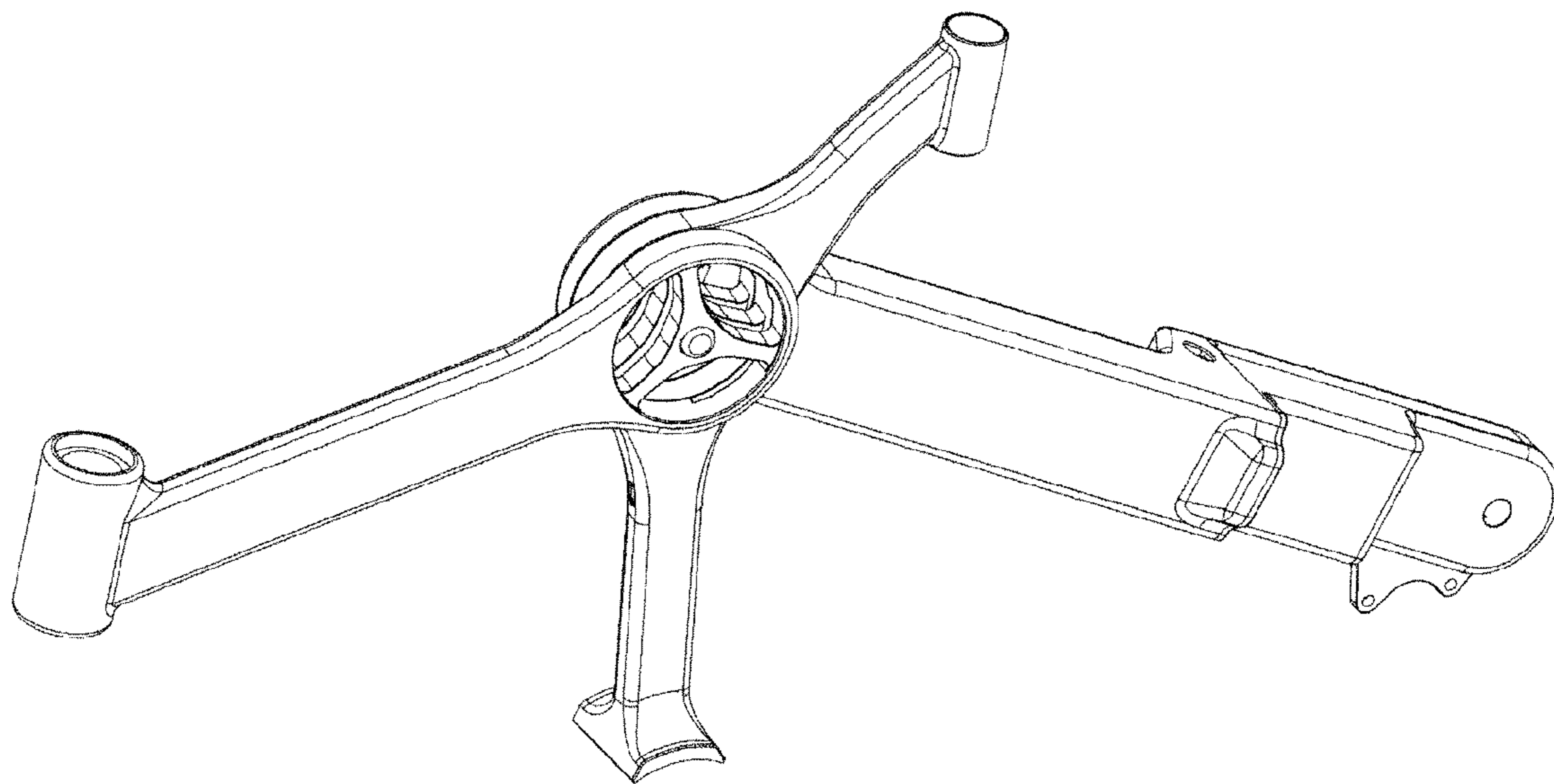

Fig. 2

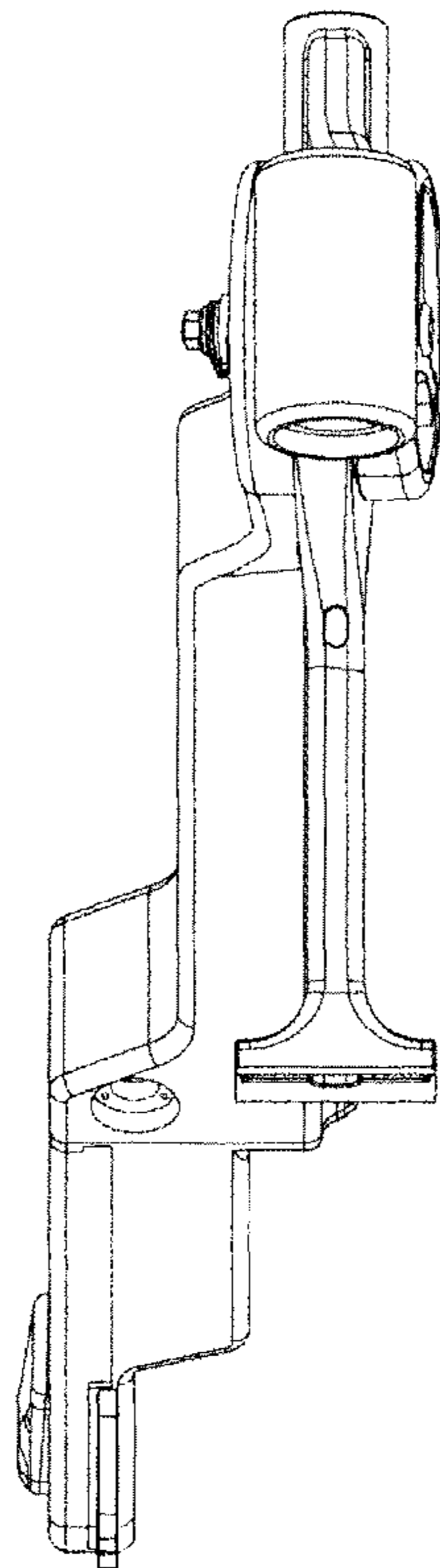

Fig. 3

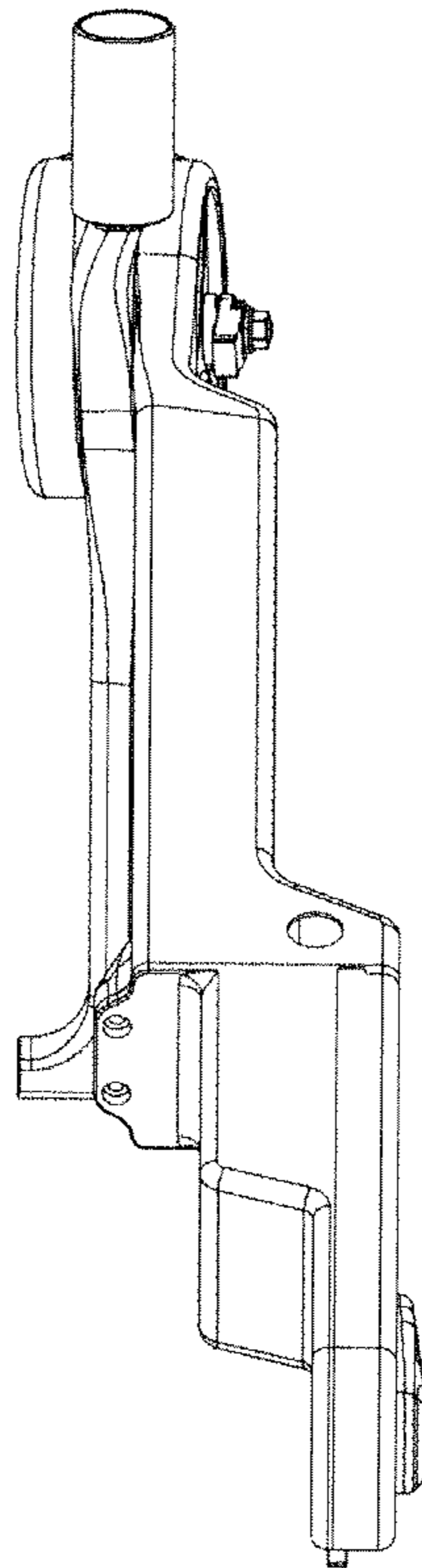

Fig. 4

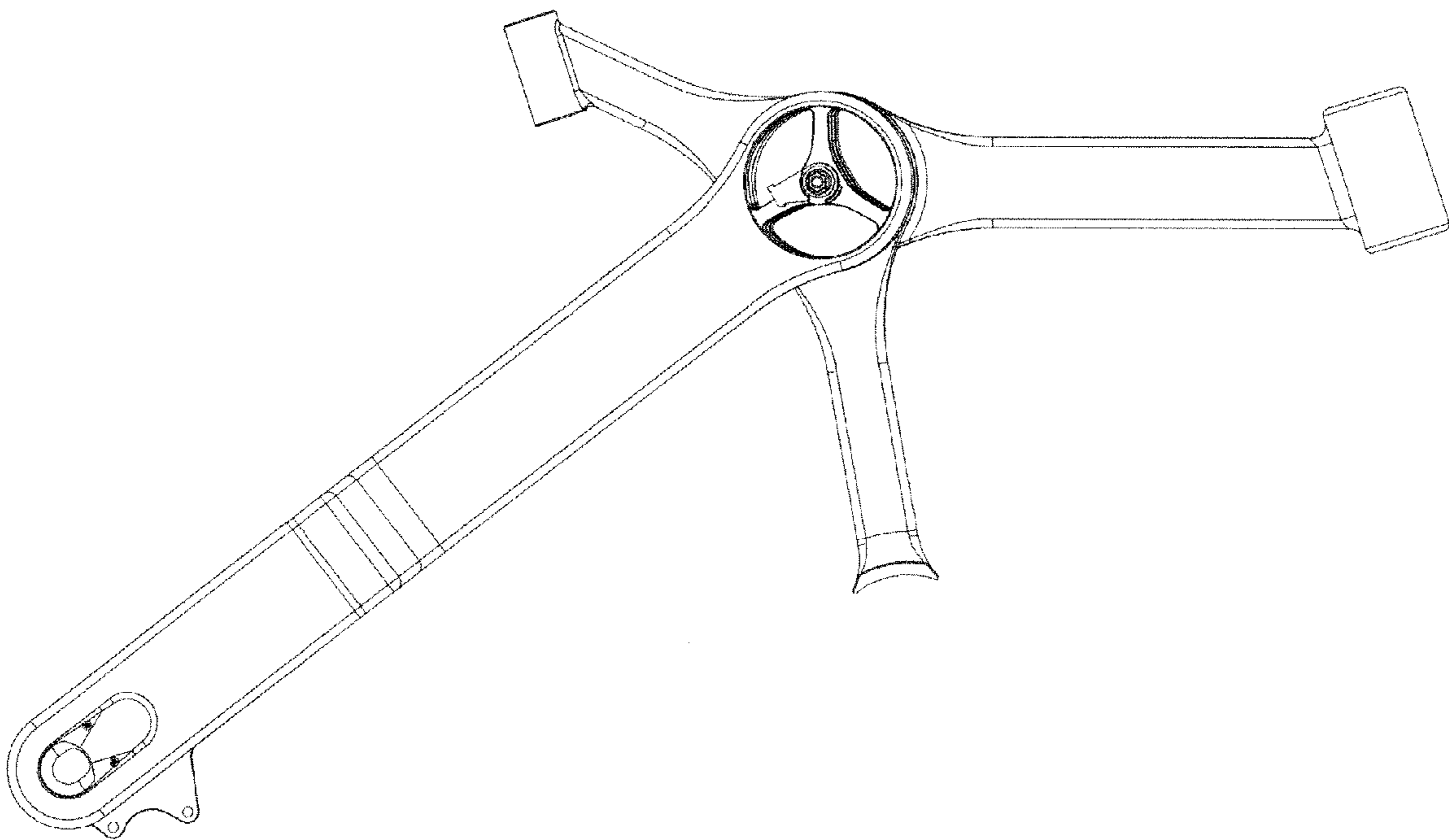

Fig. 5

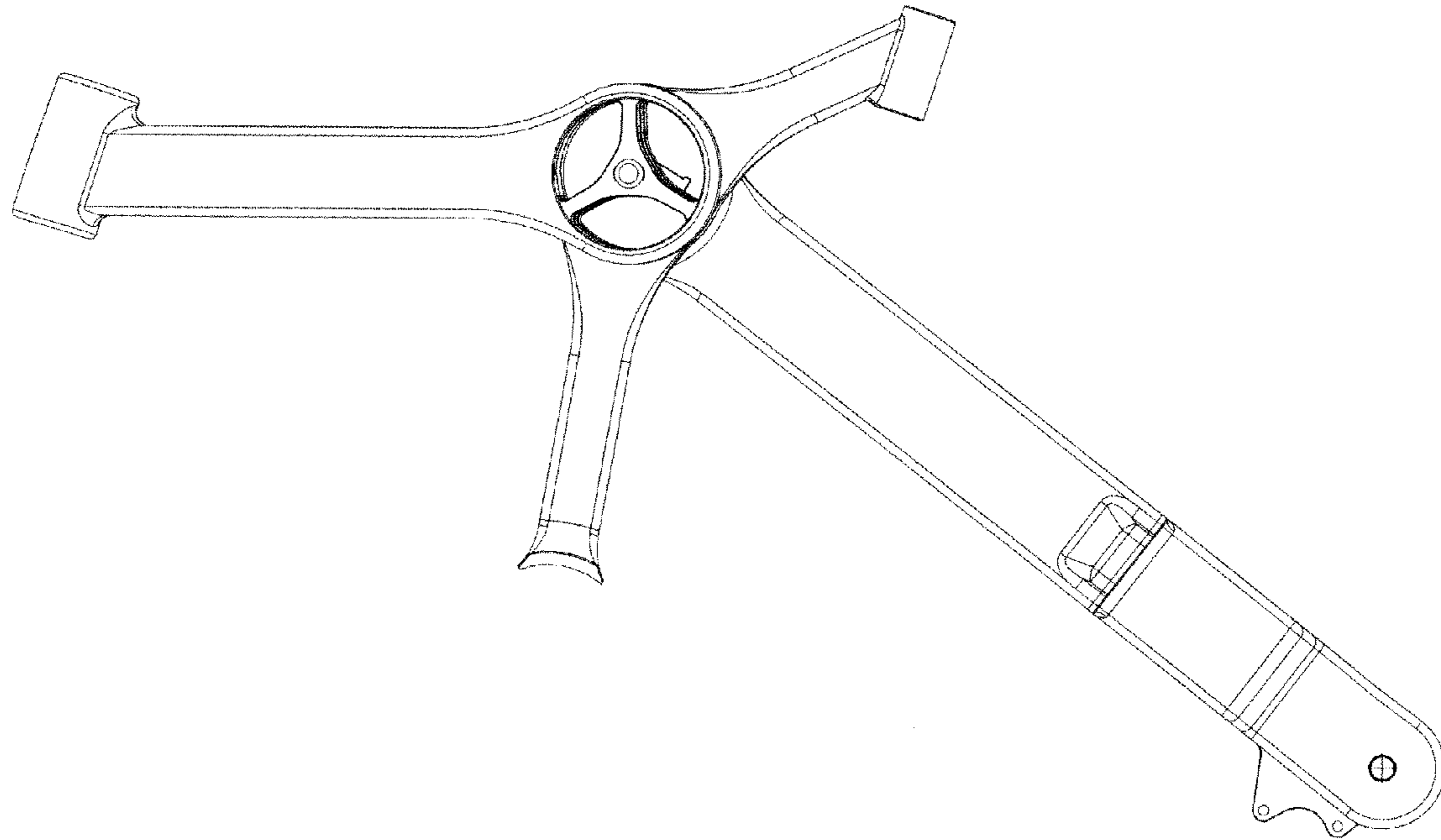

Fig. 6

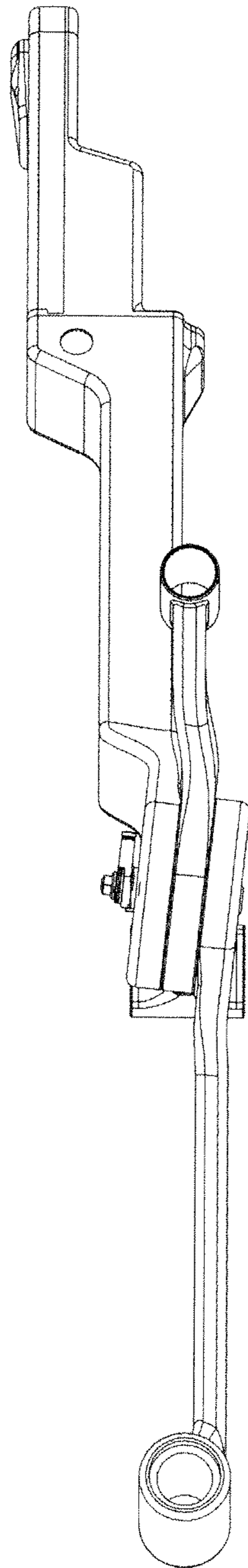

Fig. 7

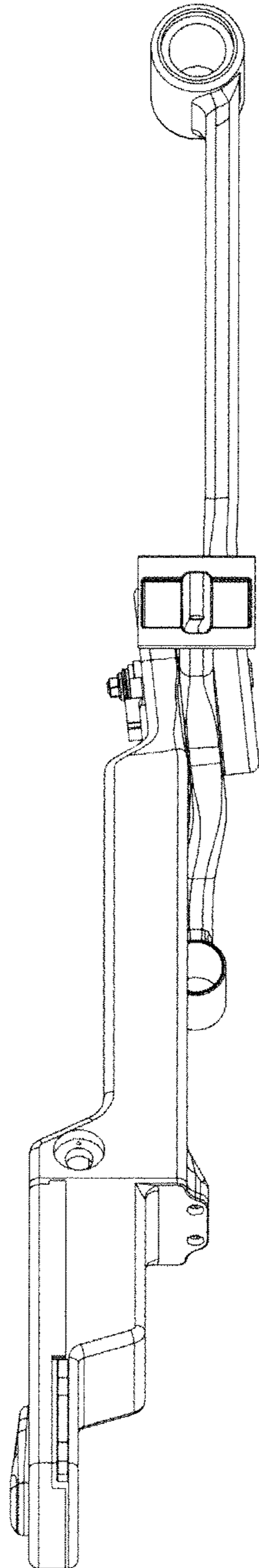

Fig. 8

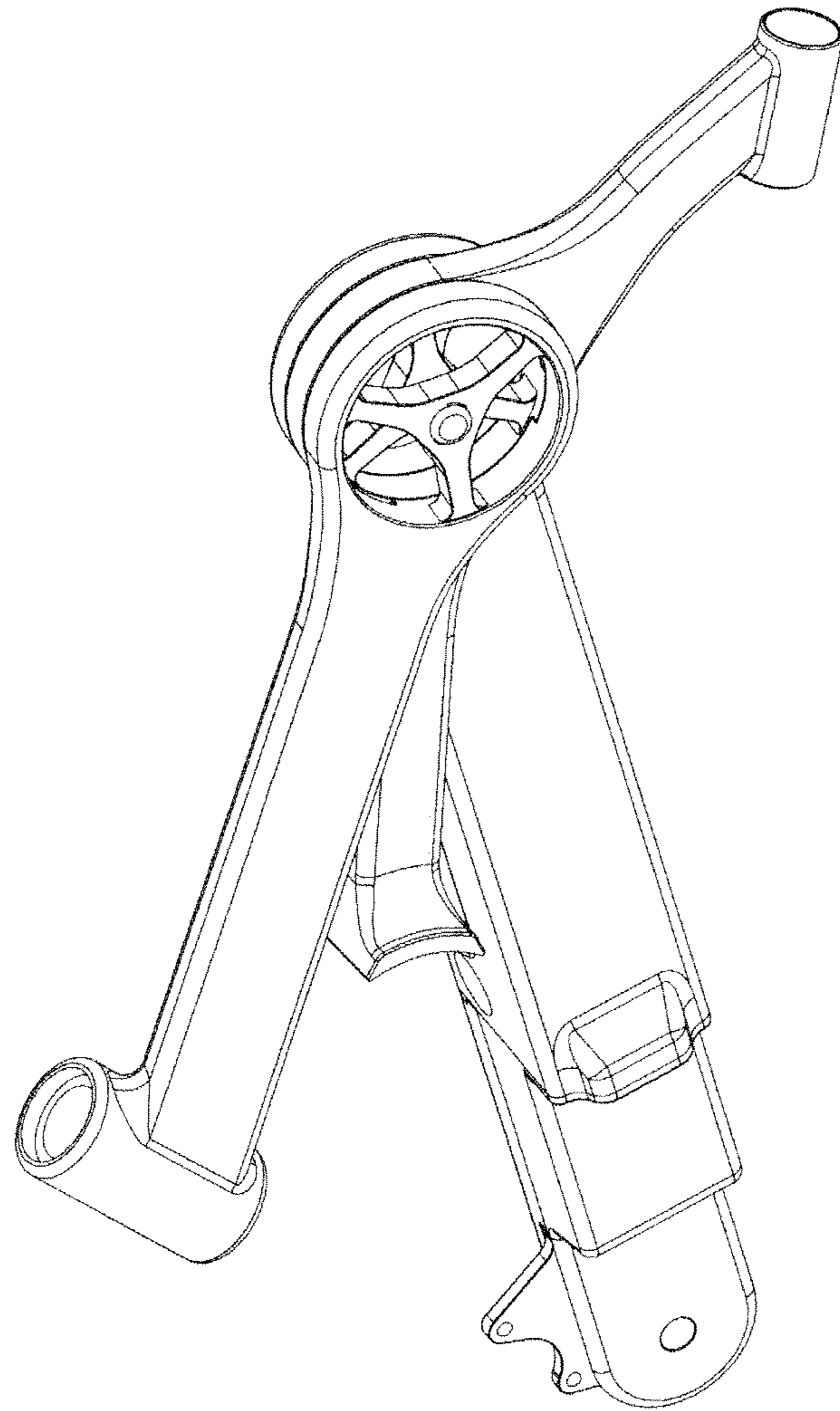

Fig. 9

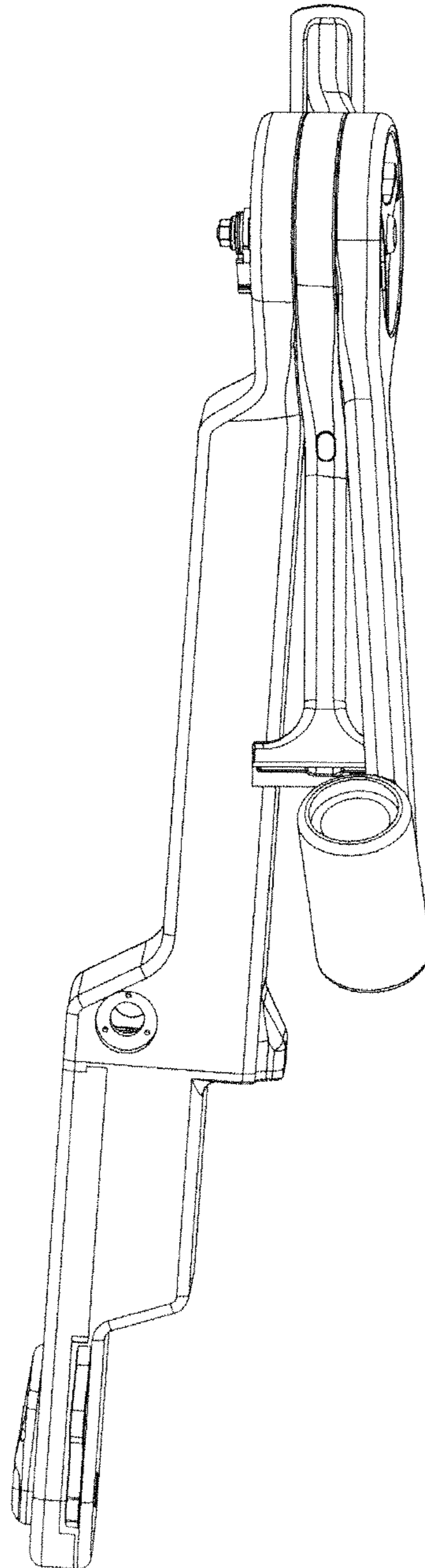

Fig. 10

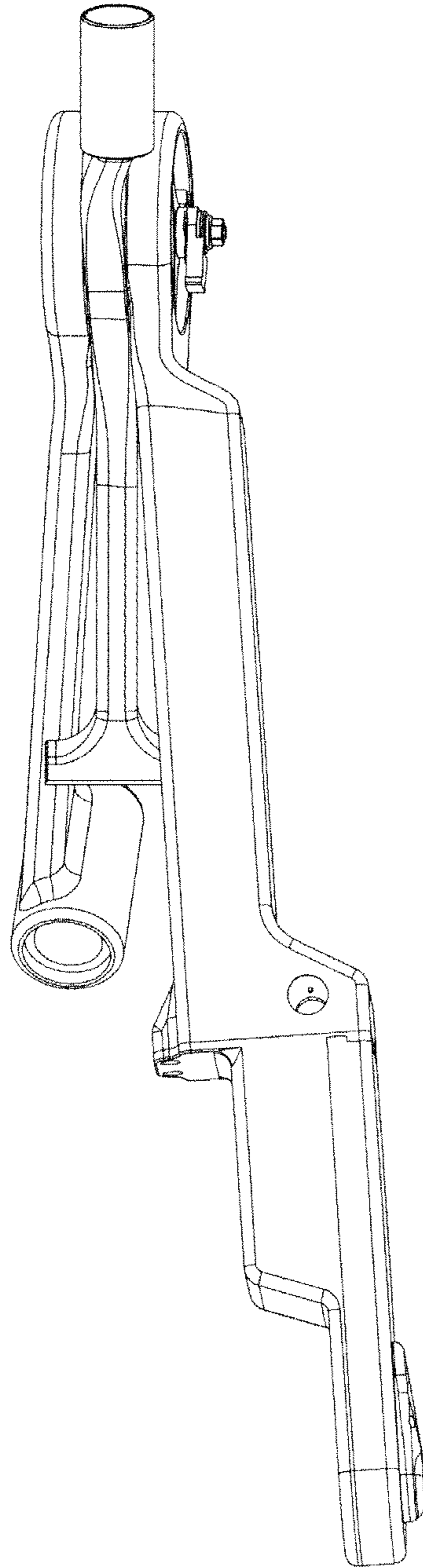

Fig. 11

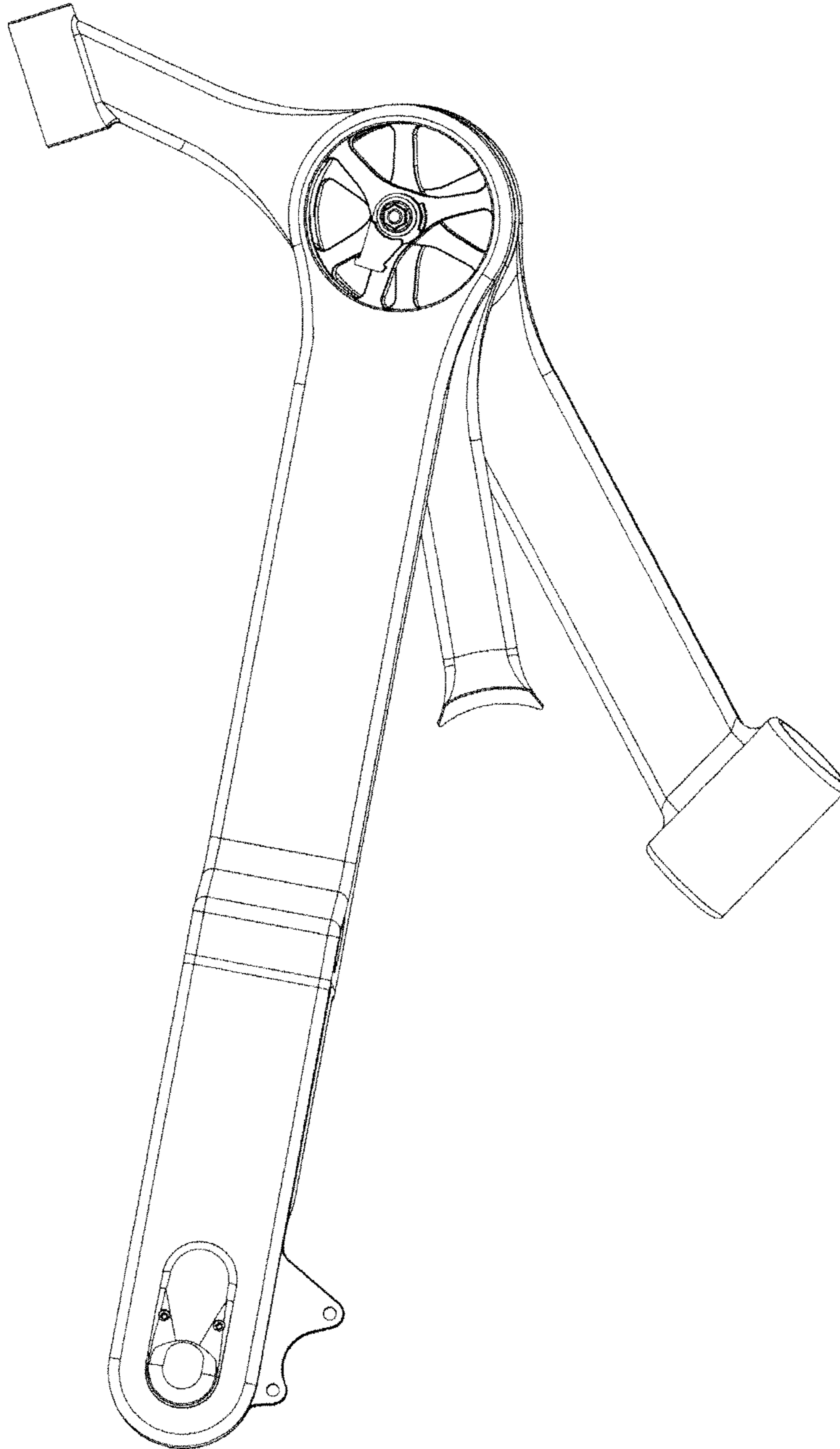

Fig. 12

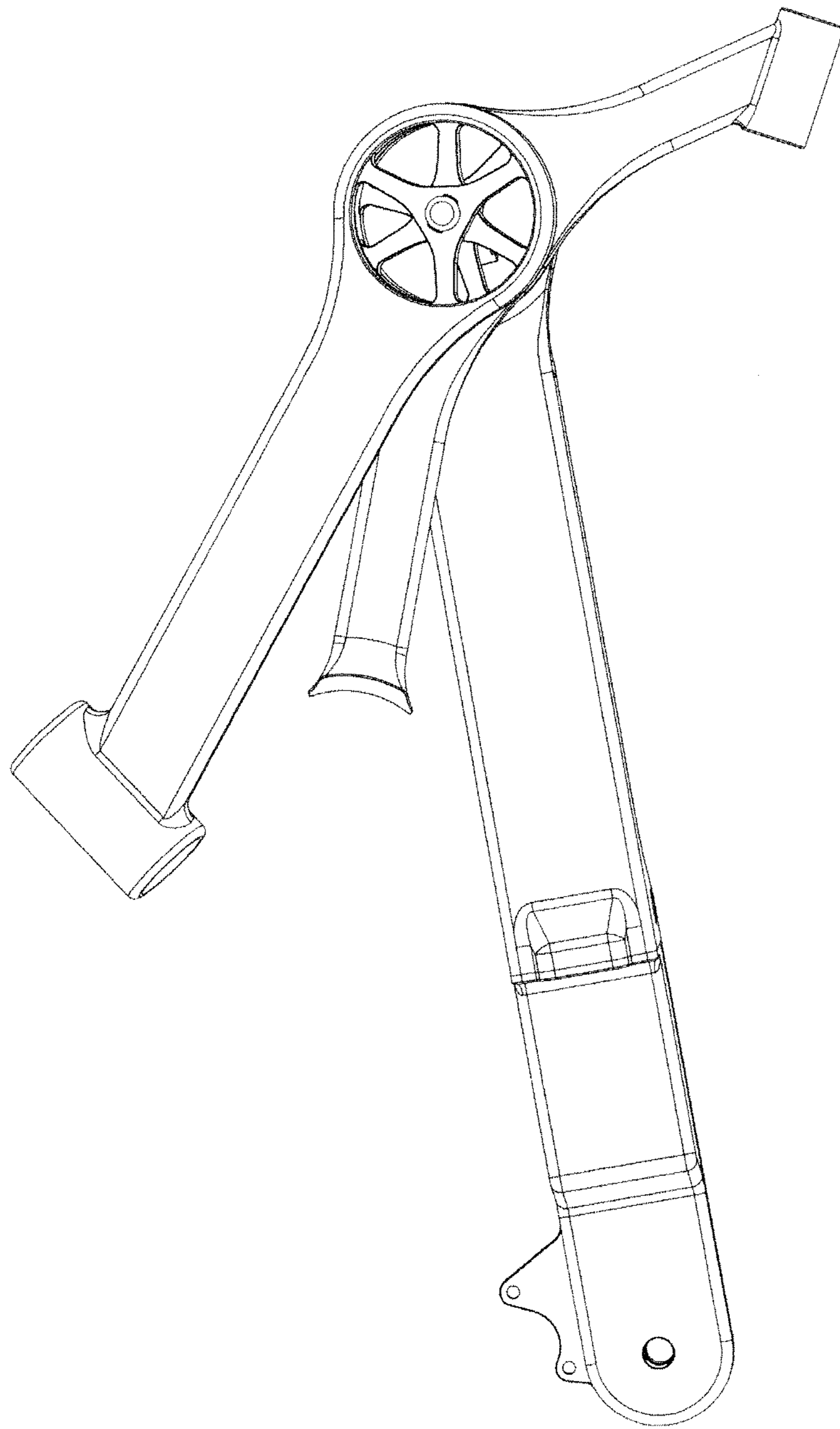

Fig. 13

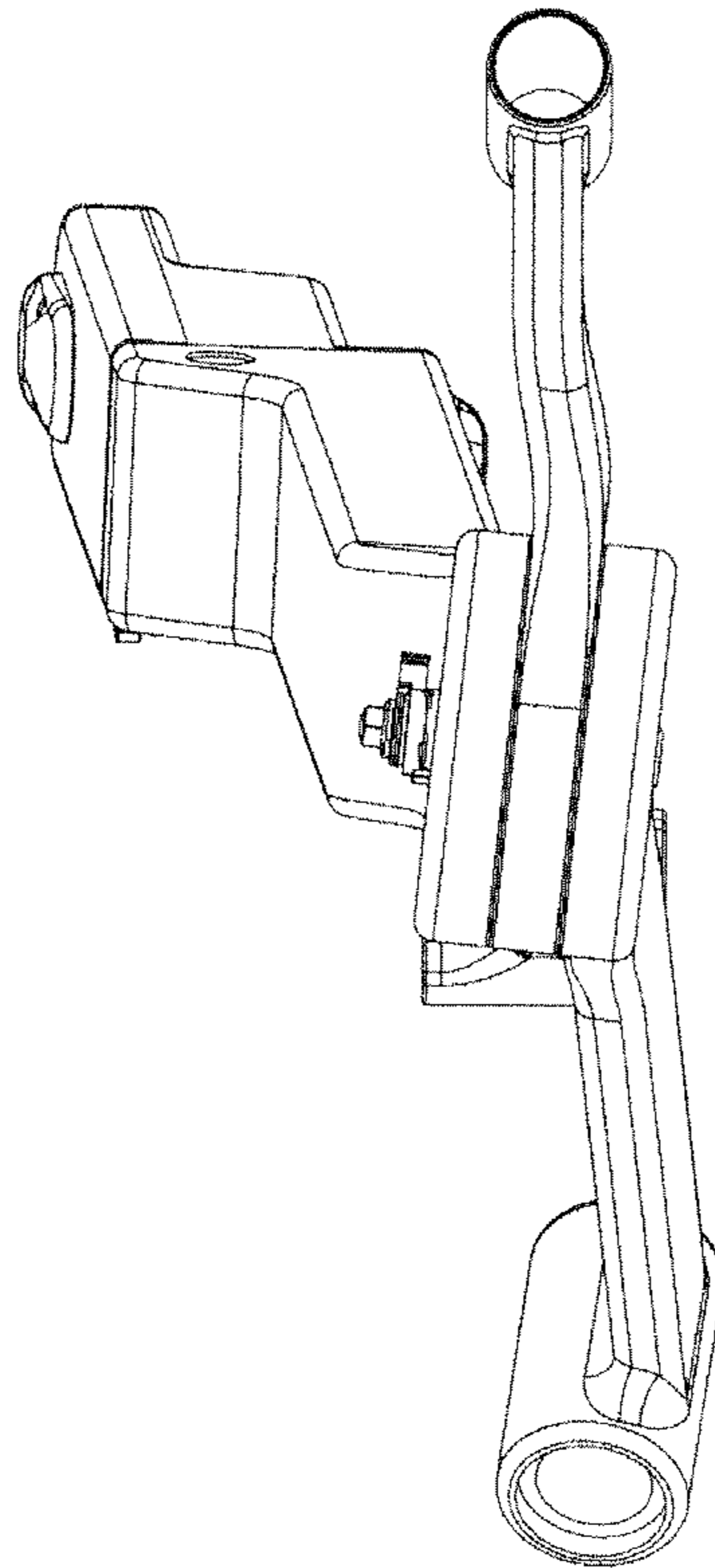

Fig. 14

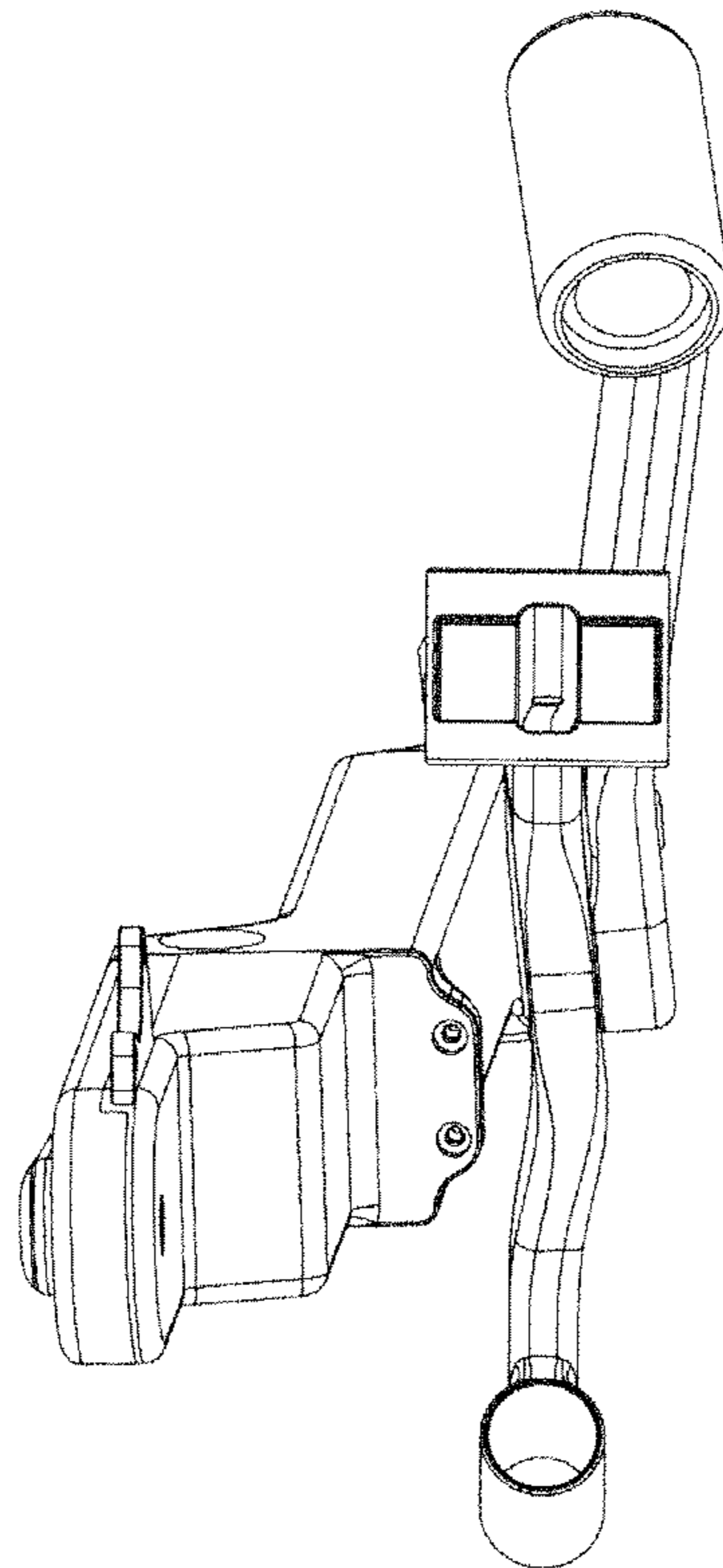

Fig. 15

