



US00RE45268E

(19) **United States**
(12) **Reissued Patent**
Ray et al.

(10) **Patent Number:** **US RE45,268 E**
(45) **Date of Reissued Patent:** **Dec. 2, 2014**

(54) **APPARATUS FOR SEISMIC DATA ACQUISITION**

(56) **References Cited**

U.S. PATENT DOCUMENTS

(71) Applicant: **Fairfield Industries, Inc.**, Sugar Land, TX (US)

3,297,982 A 1/1967 Allan
4,144,520 A 3/1979 McNeel

(Continued)

(72) Inventors: **Clifford H. Ray**, Fulshear, TX (US);
Glenn D. Fisseler, Houston, TX (US);
Hal B. Haygood, Richmond, TX (US)

FOREIGN PATENT DOCUMENTS

GB 2 275 337 8/1994
GB 2275337 A 8/1994

(Continued)

(73) Assignee: **Fairfield Industries, Inc.**, Sugar Land, TX (US)

OTHER PUBLICATIONS

(21) Appl. No.: **13/952,135**

Buttgenbach, Dr. Thomas, Schleisiek Klaus, "4-C System Goes Ultradeep," Hart's E&P, Houston, Texas/United States of America, Jan. 2002, 3 pages.

(22) Filed: **Jul. 26, 2013**

(Continued)

Related U.S. Patent Documents

Reissue of:

(64) Patent No.: **7,986,589**
Issued: **Jul. 26, 2011**
Appl. No.: **12/547,478**
Filed: **Aug. 25, 2009**

Primary Examiner — Mark Hellner
(74) *Attorney, Agent, or Firm* — Foley & Lardner LLP

(57) **ABSTRACT**

A seismic exploration method and unit comprised of continuous recording, self-contained wireless seismometer units or pods. The self-contained unit may include a tilt meter, a compass and a mechanically gimbaled clock platform. Upon retrieval, seismic data recorded by the unit can be extracted and the unit can be charged, tested, re-synchronized, and operation can be re-initiated without the need to open the unit's case. The unit may include an additional geophone to mechanically vibrate the unit to gauge the degree of coupling between the unit and the earth. The unit may correct seismic data for the effects of crystal aging arising from the clock. Deployment location of the unit may be determined tracking linear and angular acceleration from an initial position. The unit may utilize multiple geophones angularly oriented to one another in order to redundantly measure seismic activity in a particular plane.

U.S. Applications:

(60) Division of application No. 12/220,518, filed on Jul. 25, 2008, now Pat. No. 7,668,047, which is a continuation of application No. 10/766,253, filed on Jan. 28, 2004, now Pat. No. 7,561,493.

(51) **Int. Cl.**
G01V 1/00 (2006.01)

(52) **U.S. Cl.**
USPC **367/76; 367/77; 367/178; 367/188**

(58) **Field of Classification Search**
USPC **367/38, 188, 76, 79, 178**
See application file for complete search history.

49 Claims, 2 Drawing Sheets

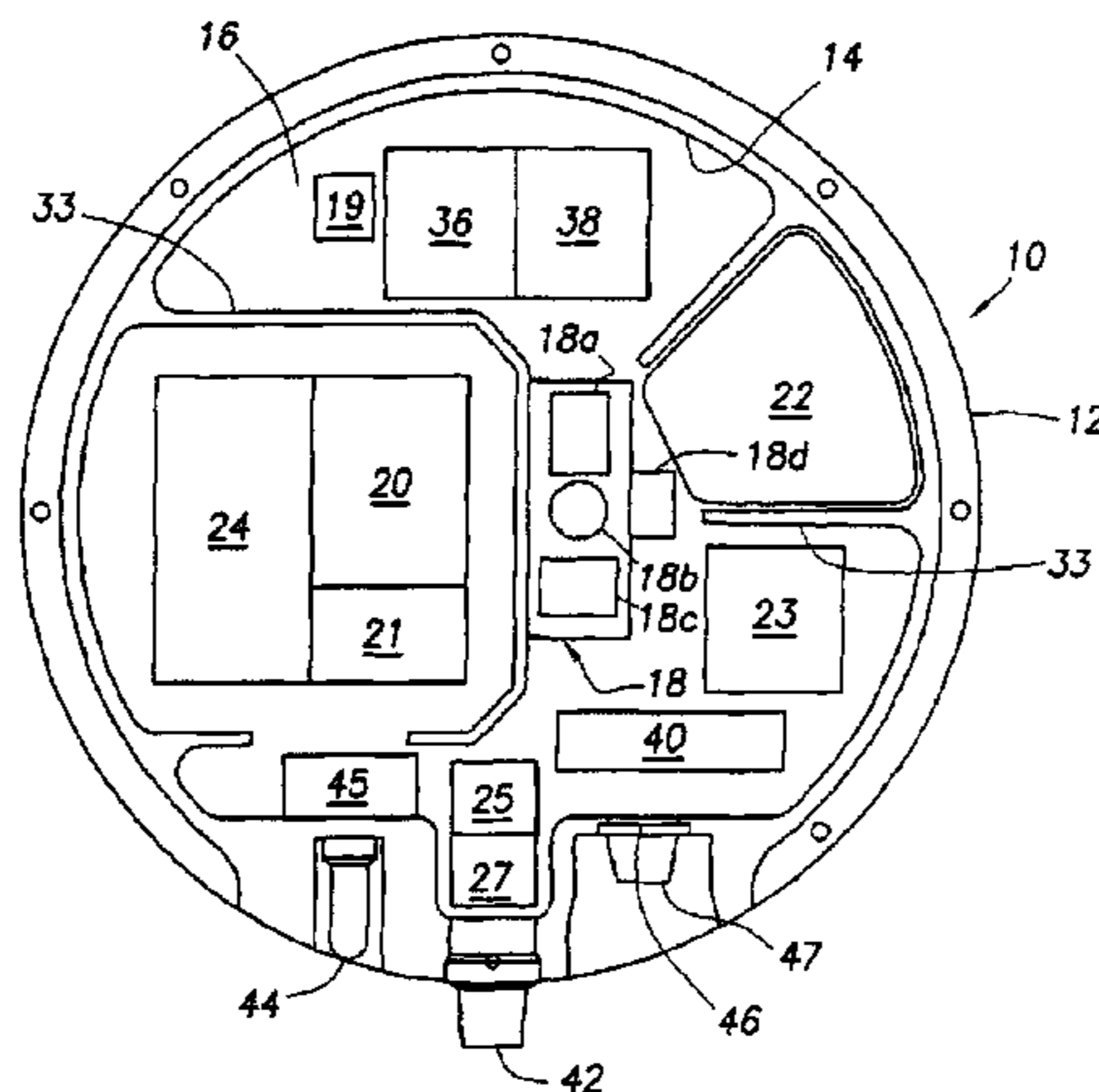

(56)

References Cited

U.S. PATENT DOCUMENTS

4,222,164 A 9/1980 Triebwasser
 4,281,403 A 7/1981 Siems et al.
 4,300,220 A 11/1981 Goff et al.
 4,380,059 A 4/1983 Ruehle
 4,422,164 A 12/1983 Bowden et al.
 4,458,339 A 7/1984 Wason
 4,462,094 A 7/1984 Bowden et al.
 4,486,865 A 12/1984 Ruehle
 4,525,819 A 6/1985 Hefer
 4,613,821 A * 9/1986 Sternberg et al. 324/323
 4,666,338 A 5/1987 Schoepf
 4,682,094 A 7/1987 Kuroiwa
 4,692,906 A 9/1987 Neeley
 4,813,029 A 3/1989 Erich et al.
 4,839,872 A 6/1989 Gragnolati
 4,849,947 A 7/1989 Baule et al.
 4,884,248 A 11/1989 Laster et al.
 4,979,150 A 12/1990 Barr
 5,003,517 A 3/1991 Greer
 5,010,531 A 4/1991 McNeel
 5,067,112 A 11/1991 Meek
 5,119,345 A 6/1992 Woo et al.
 5,138,538 A 8/1992 Sperling
 5,163,028 A 11/1992 Barr et al.
 5,189,642 A * 2/1993 Donoho et al. 367/15
 5,191,526 A 3/1993 Laster et al.
 5,214,614 A 5/1993 Baule
 5,231,252 A 7/1993 Sansone
 5,253,223 A 10/1993 Svenning
 5,274,605 A 12/1993 Hill
 5,365,492 A 11/1994 Dragoset et al.
 5,432,895 A 7/1995 Myers
 5,469,408 A 11/1995 Woo
 5,500,832 A 3/1996 Berryhill
 5,548,562 A 8/1996 Helgerud
 5,550,786 A 8/1996 Allen
 5,623,455 A 4/1997 Norris
 5,624,207 A 4/1997 Berges
 5,655,753 A 8/1997 Berges
 5,671,344 A 9/1997 Stark
 5,724,241 A * 3/1998 Wood et al. 702/14
 5,761,152 A 6/1998 Jacobsen et al.
 5,774,417 A 6/1998 Corrigan et al.
 5,902,072 A 5/1999 Berges
 5,930,730 A 7/1999 Marfurt et al.
 6,002,640 A * 12/1999 Harmon 367/38
 6,012,018 A 1/2000 Hornbuckle
 6,021,090 A 2/2000 Gaiser et al.
 6,024,344 A 2/2000 Buckley et al.
 6,049,507 A 4/2000 Allen
 6,070,129 A 5/2000 Grouffal et al.
 6,101,448 A 8/2000 Ikelle et al.
 6,141,622 A 10/2000 Keller et al.
 6,151,556 A 11/2000 Allen
 6,208,247 B1 * 3/2001 Agre et al. 340/539.19
 6,215,499 B1 4/2001 Neff et al.
 6,292,754 B1 9/2001 Thomsen
 6,307,808 B1 10/2001 Schmidt
 6,314,371 B1 11/2001 Monk

6,353,577 B1 * 3/2002 Orban et al. 367/43
 6,366,537 B1 4/2002 Sambuelli et al.
 6,430,105 B1 * 8/2002 Stephen 367/15
 6,532,190 B2 3/2003 Bachrach
 6,584,406 B1 6/2003 Harmon et al.
 6,607,050 B2 8/2003 He et al.
 6,657,921 B1 12/2003 Ambs
 6,738,715 B2 5/2004 Shatilo et al.
 6,751,162 B2 6/2004 Dominguez et al.
 6,791,901 B1 9/2004 Robertsson et al.
 6,814,179 B2 11/2004 Corrigan et al.
 6,816,434 B2 11/2004 Jones
 6,850,462 B2 2/2005 McDaniel et al.
 6,912,903 B2 7/2005 Hamblen et al.
 6,934,219 B2 8/2005 Burkholder
 6,977,867 B2 12/2005 Chamberlain
 7,016,260 B2 3/2006 Bary
 7,021,146 B2 4/2006 Nash et al.
 7,085,196 B2 8/2006 Nemeth
 7,310,287 B2 12/2007 Ray et al.
 7,324,406 B2 1/2008 Berg
 7,986,589 B2 7/2011 Ray et al.
 8,228,761 B2 7/2012 Ray et al.
 2003/0202424 A1 10/2003 Burkholder et al.
 2004/0073373 A1 4/2004 Wilson
 2005/0144795 A1 7/2005 Tanner
 2005/0246137 A1 11/2005 Brinkman et al.

FOREIGN PATENT DOCUMENTS

WO 9710461 9/1996
 WO WO-97/10461 A1 3/1997
 WO WO-01/96672 A1 12/2001
 WO WO-02/37140 A2 5/2002

OTHER PUBLICATIONS

Canadian Office Action DTD May 24, 2013 for Application No. 2581193, filed Mar. 20, 2007, 3 pages.
 Canadian Office Action DTD Aug. 1, 2012 for Application No. 2554788, filed Jul. 27, 2006, 3 pages.
 Geopro GmbH, "WARRP Offshore," GeoPro GmbH, Hamburg/Germany, Mar. 2002, 2 pages.
 Thales Underwater Systems, "Reservoir Monitoring Solutions," Thales, Jan. 2003, 18 pages.
 US Office Action DTD Jul. 12, 2013 for related U.S. Appl. No. 13/565,445, filed Aug. 2, 2012, 4 pages.
 Office Action in Chinese Application No. 201210243445.3 dated Jun. 17, 2014 (English translation included—10 pages).
 Notice of Allowance in U.S. Appl. No. 13/565,445 dated Jul. 8, 2014 (5 pages).
 Final Office Action in corresponding U.S. Appl. No. 13/565,445, filed Aug. 2, 2012, 11 pages.
 First Examination Report for European Patent Application No. 04809786.9 dated Sep. 9, 2013, 3 pages.
 Notification of the First Office Action in corresponding Chinese Application No. 201110436777.9 dated Feb. 28, 2014, 7 pages.
 Seabed Geophysical AS, "Case, Cable-less SEIsmic System," 8 pages, SeaBed Geophysical AS, Trondheim/Norway.

* cited by examiner

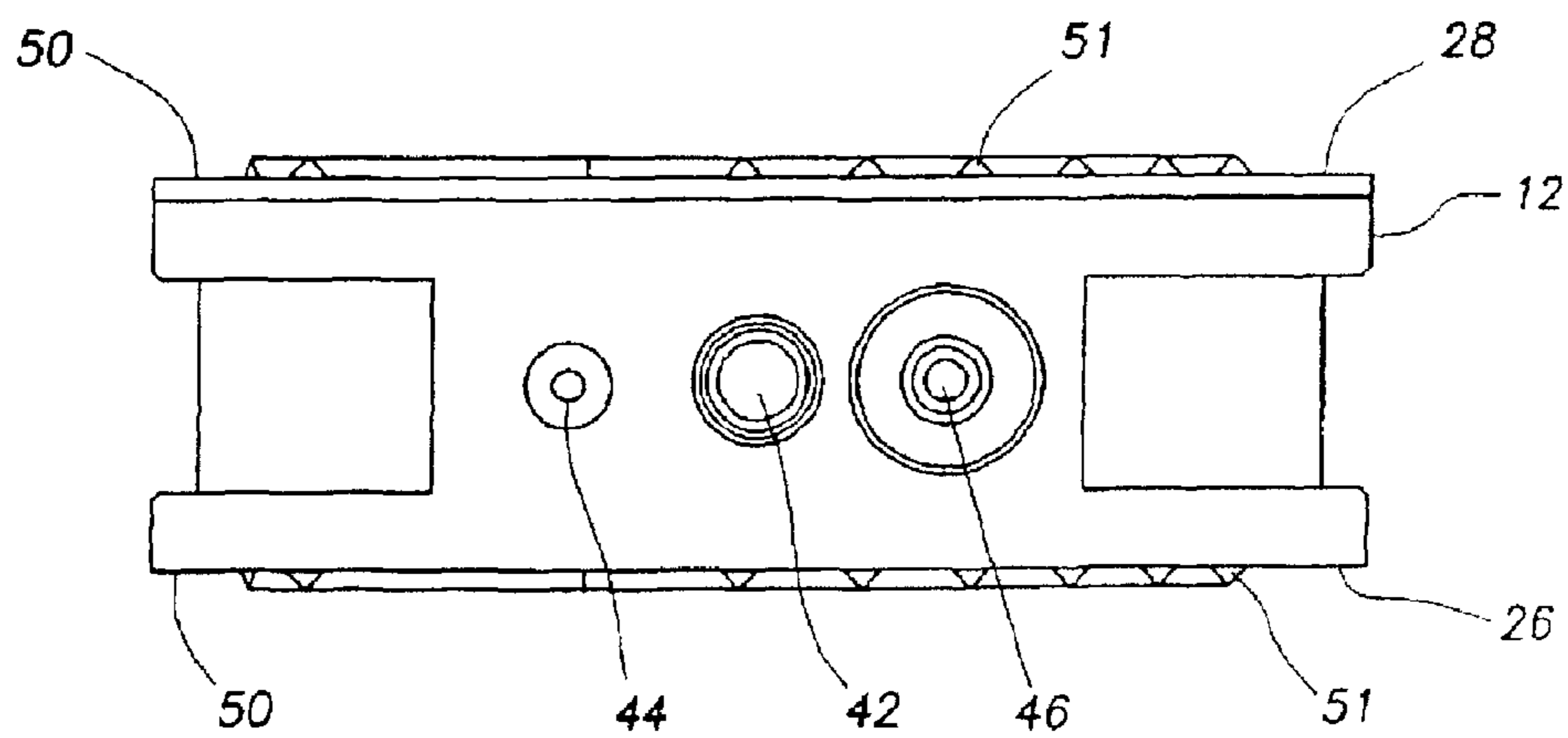
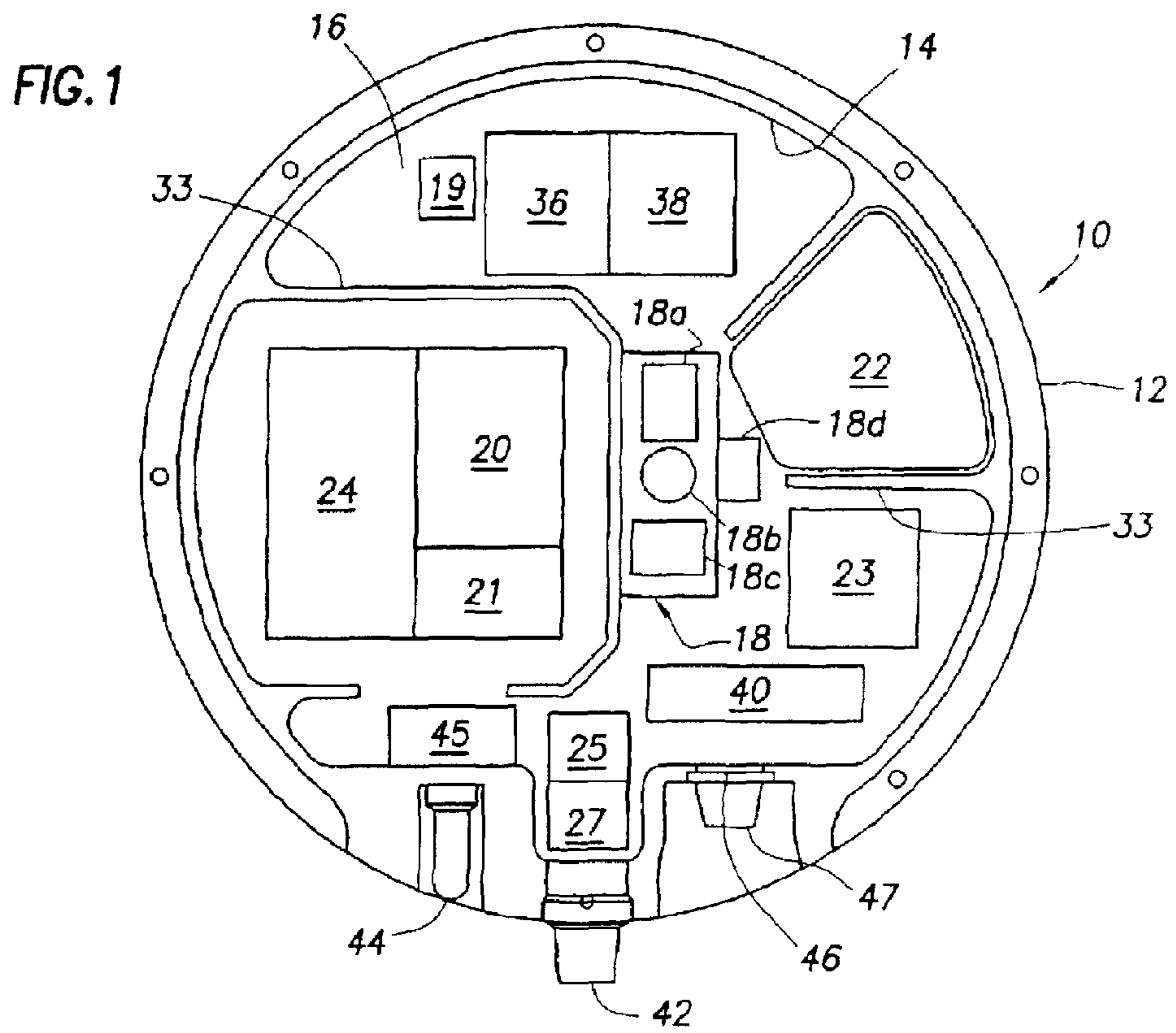

FIG.4

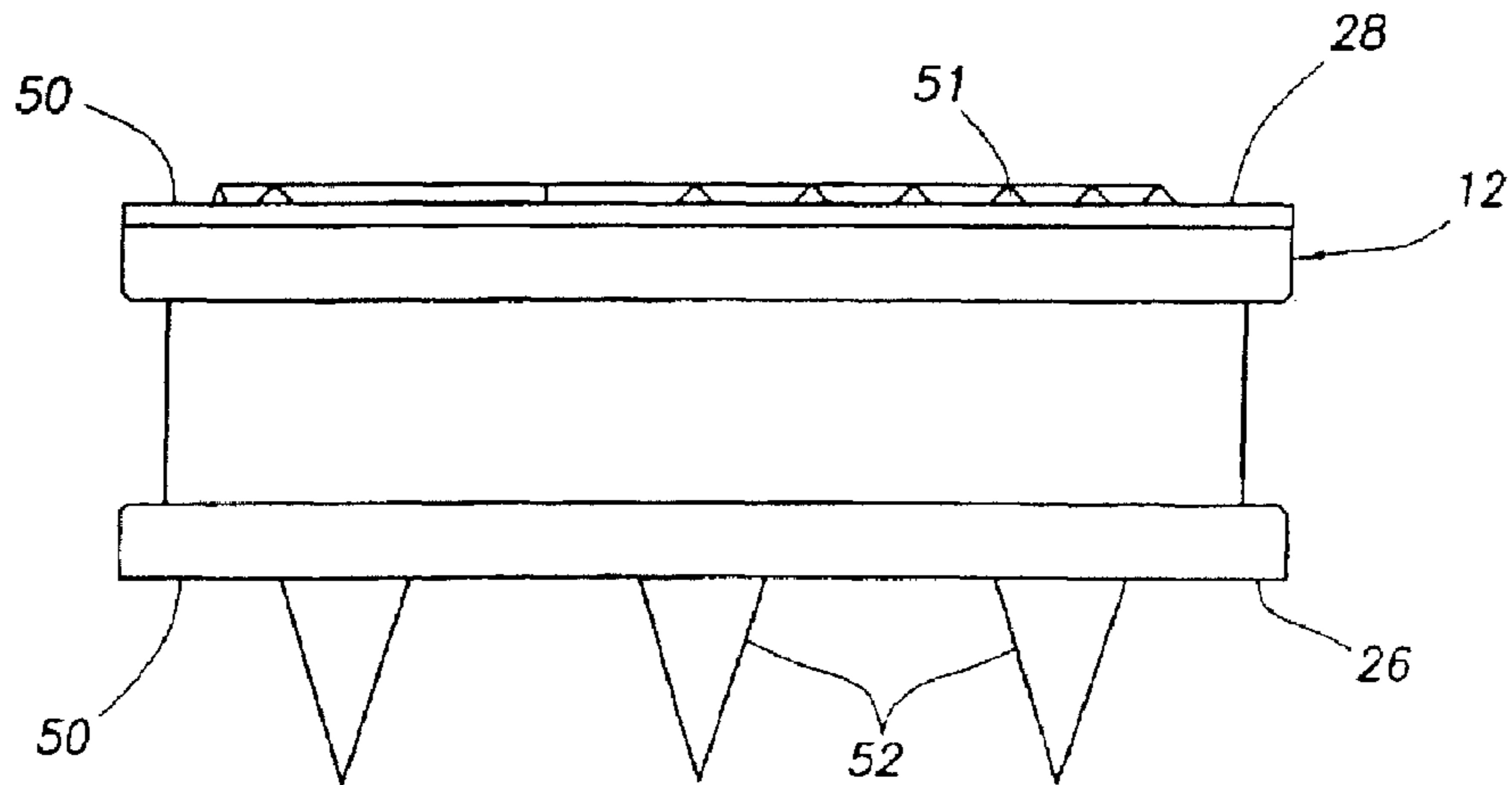
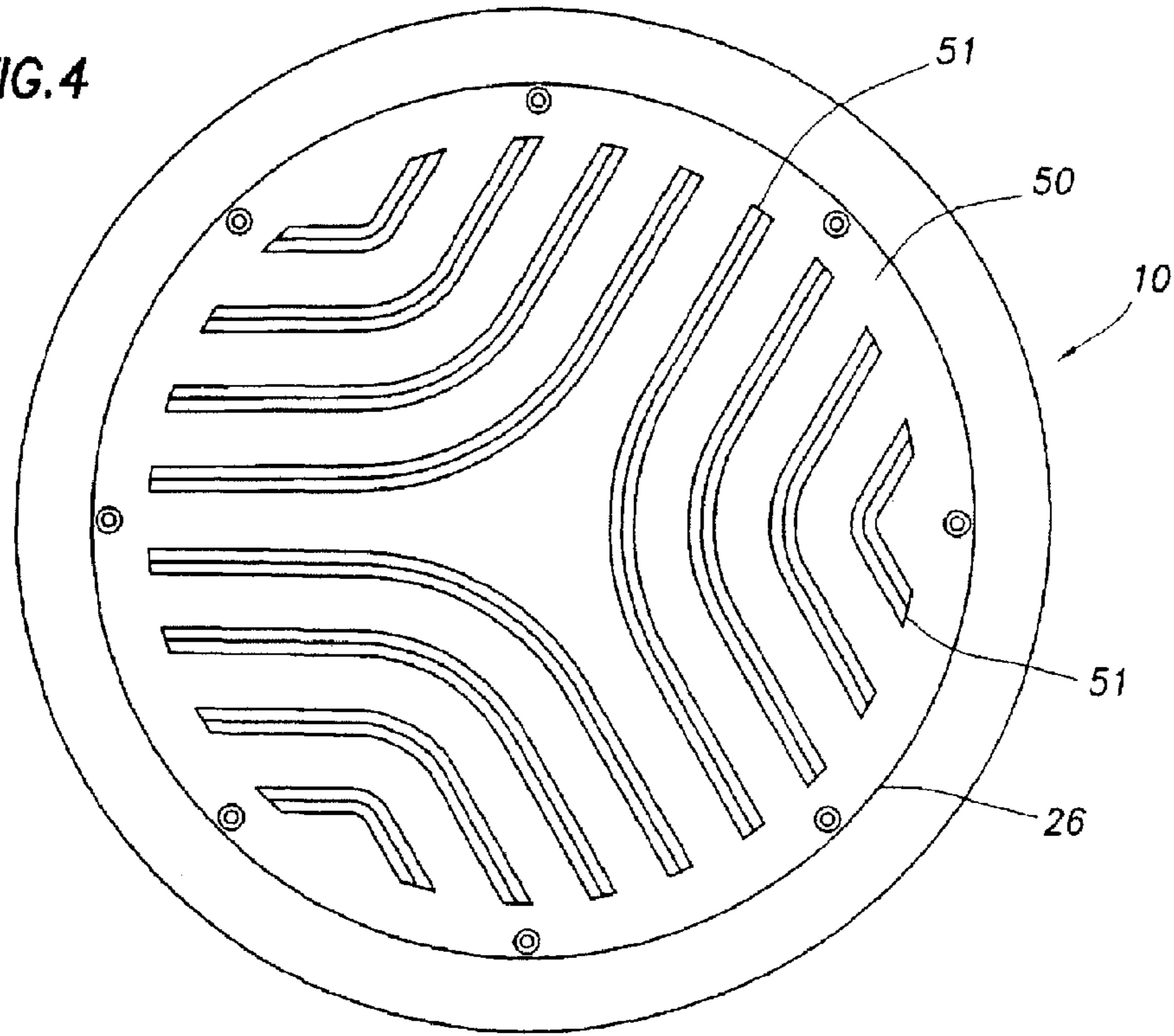

FIG.3

APPARATUS FOR SEISMIC DATA ACQUISITION

Matter enclosed in heavy brackets [] appears in the original patent but forms no part of this reissue specification; matter printed in italics indicates the additions made by reissue.

CROSS REFERENCE TO RELATED APPLICATIONS

This application is a divisional of U.S. patent application Ser. No. 12/220,518, filed Jul. 25, 2008, now U.S. Pat. No. 7,668,047, which is a divisional of U.S. patent application Ser. No. 10/766,253, filed Jan. 28, 2004, which claims priority to and the benefit of U.S. Pat. No. 7,561,493, filed on May 30, 2003, all of which are hereby incorporated by reference.

BACKGROUND

The present invention relates to the field of seismic exploration. More particularly, the invention relates to a method and apparatus for seismic exploration, and most particularly to a self-contained, land based or marine deployable seismometer system.

Seismic exploration generally utilizes a seismic energy source to generate an acoustic signal that propagates into the earth and is partially reflected by subsurface seismic reflectors (i.e., interfaces between subsurface lithologic or fluid layers characterized by different elastic properties). The reflected signals (known as "seismic reflections") are detected and recorded by seismic receivers located at or near the surface of the earth, thereby generating a seismic survey of the subsurface. The recorded signals, or seismic energy data, can then be processed to yield information relating to the lithologic subsurface formations, identifying such features, as, for example, lithologic subsurface formation boundaries.

Typically, the seismic receivers are laid out in an array, wherein the array consists of a line of stations each comprised of strings of receivers laid out in order to record data from the seismic cross-section below the line of receivers. For data over a larger area and for three-dimensional representations of a formation, multiple single-line arrays may be set out side-by-side, such that a grid of receivers is formed. Often, the stations and their receivers are remotely located or spread apart. In land seismic surveys for example, hundreds of thousands of receivers, called geophones, may be deployed in a spatially diverse manner, such as a typical grid configuration where each line extends for 5000 meters with receivers spaced every 25 meters and the successive lines are spaced 500 meters apart.

Generally, several receivers are connected in a parallel-series combination on a single twisted pair of wires to form a single receiver group or channel for a station. During the data collection process, the output from each channel is digitized and recorded for subsequent analysis. In turn, the groups of receivers are usually connected to cables used to communicate with the receivers and transport the collected data to recorders located at a central location, often called the "dog house." More specifically, when such surveys are conducted on land, cable telemetry is used for data transmission between the individual receivers, the stations and the dog house. Other systems use wireless methods for data transmission so that the individual receivers and stations are not connected to each other. Still other systems temporarily store the data at each station until the data is extracted.

As used throughout this description, "land-based seismic systems" shall include seismic systems utilized in coastal transition zones such as shallow water or marshes. With respect to operation of most land-based seismic systems, the prior art generally requires some externally generated control command in order to initiate and acquire data for each shot, cause stored seismic data to be transmitted back to the dog house and cause any other data, such as quality control data, to be transmitted back to the dog house. Thus the seismic receiver units must be either physically connected to the central control recording station or "connectable" by wireless techniques. As mentioned above, those skilled in the art will understand that certain environments can present extreme challenges for conventional methods of connecting and controlling seismic, such as congested or marine environments, rugged mountain environments and jungles or remote desert locations. Difficulties may also arise in instances where the interconnected, hard-wired receiver array must be periodically moved to cover a larger area.

Whatever the case, each type of connection, whether via a physical cable or through wireless techniques, has its own drawbacks. In cable telemetry systems, large arrays may result in large quantities of electrically conductive cabling that are expensive and difficult to handle, deploy or otherwise manipulate, as well as repair and maintain. In hostile environments characterized by extreme or corrosive conditions, such as salt water, hot, sandy deserts or overgrown, damp jungles, costly cable armoring may be required. Furthermore, conventional cabling also requires a physical connection between the cable and the sensor unit. Since it is generally not practical to hard wire strings of receivers to a cable, the more conventional technique is to use external cabling and connectors between strings of receivers and the telemetry cable. This point of the connection between the cable and the sensor is particularly vulnerable to damage, especially in extreme or corrosive environments. Of course, with systems that are physically cabled together, it is much easier to provide power to the stations/units, to synchronize data acquisition with the shot time, to perform quality control checks and to otherwise control the units.

It should be noted that whether for cabled or wireless systems, the seismic recording systems of the prior art separate the receiver package, i.e., the geophones, from the radio control package and/or the recording package of the units to the extent the units provide any on-board recording. It has heretofore been conventional thinking in the prior art that geophone coupling with the earth can be maximized in this way. External cabling is required in these prior art systems to connect the geophone package of a unit with the recording and/or radio telemetry packages of the unit. As such, many of the aforementioned drawbacks that arise from cabling system units together also exist when cabling various package components of an individual unit to one another.

In cases where either wireless technology is utilized or operation of units and their sensors is through pre-programming, control and monitoring of the units and sensors becomes more difficult. For example, ensuring that recording is synchronized with the shot timing is crucial since the individual sensor units are not wired together as described above. Hence the need for accurate on-board clocks as mentioned above. In this regard, activating each unit for sensing and recording at the appropriate time must coincide with the shot. One common prior art technique in this regard is to utilize a command signal sent from the control station to power up the system, initiate transmission of data stored from the previous shot and initiate collection of data for the current shot which

is temporarily written into memory until transmitted back to the control station at the time of the next shot.

Ensuring that the units are sufficiently powered has also heretofore been a concern. Many prior art patents have focused on techniques and mechanisms for powering up sensors during data acquisition/recording and powering down the sensors during dormant periods.

A land-based system representative of the prior art is taught in U.S. Pat. No. 6,070,129, which pertains to the compression and distribution of seismic data from a plurality of acquisition units, each unit being suited to acquire, to temporarily store and to compress the data for distributed transmission to a central control and recording station. Each acquisition unit is hard wired to a plurality of distributed seismic geophones/receivers from which the acquisition unit receives data. Each acquisition unit is also disposed to receive operation instructions from the central control and recording station. In one embodiment of the invention, during acquisition of data from a particular shot, partial data from the previous shot is transmitted to the central control and recording station to permit a quality control check and to ensure that the acquisition units are properly working. Data from any given shot may be distributed and transmitted over multiple transmission channels and during successive transmission windows to lessen variation in data flow.

Each of the referenced prior art devices embodies one or more of the drawbacks of the prior art. One drawback to these prior art systems is the need to activate and deactivate the units for recording and operation, including data and quality control transmission. For land-based systems, this generally requires a control signal transmitted via a cable or radio signal from the dog house. However, external control may be undesirable since it requires signal transmission and additional components in the system. Of course, any type of control signal cabling for transmission of electrical signals is undesirable because it adds a level of complexity to the handling and control of the unit and requires external connectors or couplings. Such cabling and connectors are particularly susceptible to leakage and failure in extreme environments, whether the corrosive environment of transition zone water or the high temperature, corrosive environments of the desert.

A similar problem exists with units that utilize external electrical wiring to interconnect distributed elements of the unit, such as is taught in U.S. Pat. No. 5,189,642 and similar devices where the geophone package is separate from the electronics package. Furthermore, to the extent the electronics of a system are distributed, the likelihood of malfunction of the system increases.

Many of the prior art systems also use radio telemetry rather than recording data on-board the unit, to collect the data. Such systems, of course, have limitations imposed by the characteristics of radio transmission, such as radio spectrum license restrictions, range limitations, line-of-sight obstructions, antenna limitations, data rate limitations, power restrictions, etc.

Thus, it would be desirable to provide a land-based seismic data collection system that does not require external communication/power cabling, either from the control station or on the seismic data collection unit itself between unit components. Likewise, the unit should record and otherwise operate without any type of external control signal. In other words, the unit should operate on a "drop and forget" basis. Likewise, the device should be easily serviced without the need to open the device to perform activities such as data extraction, quality control and power replenishment. The device should also be designed to withstand the corrosive, extreme environments which are often encountered in seismic exploration. The

device should also permit quality control data sent back by radio to determine if the remote units of the system are operating properly without the need for control signals or tying the quality control data transmission to a shot cycle.

SUMMARY

The present invention provides a land-based system for collecting seismic data by deploying multiple, continuous operating, autonomous, wireless, self-contained seismic recording units or pods. Seismic data previously recorded by the pod can be retrieved and the pod can be charged, tested, re-synchronized, and operation can be re-initiated without the need to open the pod.

More specifically, the unit is self-contained such that all of the electronics are disposed within or on the case, including a geophone package, a seismic data recording device and a clock. A power source is either contained within the case, or may be attached externally to the case. The clock may be attached to a gimbaled platform having multiple degrees of freedom to minimize the effects of gravity on the clock.

In one embodiment of the invention, the clock is a rubidium clock. The rubidium clock is much less susceptible to temperature or gravitational effects or orientation of the unit.

In another embodiment, the unit includes a crystal clock and the crystal clock is corrected for the effects of aging on the crystals.

The power source is preferably rechargeable batteries disposed within the unit's case that can operate in a sealed environment, such as lithium ion batteries. Alternatively, the power source may incorporate a fuel cell or solar cell attached to the unit's case.

The self-contained seismic units may include a tilt meter within the unit's case. While tilt meter data is utilized by the invention for several different inventive functions, such as the above-mentioned crystal clock correction procedure, none of the prior art seismic units have incorporated a tilt meter within a seismic unit comprising a single, self-contained package. Rather, such prior art units have separate attached packages housing the separate components. For example, a prior art unit may have one package that houses a tilt meter while a separate package houses a geophone.

Of course, a tilt meter may also be used to determine the vertical orientation of a unit so that corresponding seismic data can be correct accordingly. One aspect of the invention is to obtain and utilize tilt meter data in a time continuous fashion. Prior art units typically determine a unit's vertical orientation using means external to said case and orientation data are generated therefrom only once at the beginning of seismic recording. To the extent orientation corrections have been made to seismic data acquired with such prior art units, the corrections are based only on the initial orientation of the unit. Yet it has been observed that the orientation of a seismic unit may change over the course of deployment as the unit is subject to external forces which have been known to range from water currents to kicking by cows. Thus, in the invention, vertical orientation data is measured by the tilt meter as a function of time so that seismic data can be correspondingly corrected.

With respect to corrections for tilt, timing or similar data that could effect the accuracy of the collected seismic data, all of the prior art devices make such corrections at a processing center. None of the prior art devices make such corrections on-board the unit while it is deployed. Thus, one method of the invention is to make such corrections on-board the unit while it is deployed.

5

The self-contained seismic units of the invention may also include a compass. Compass data may be used to provide directional frame of reference data for each individual unit relative to the frame of reference for the overall survey. Much like a tilt meter, the prior art has not incorporated a compass into a single, self-contained package housing all the components of the seismic acquisition unit. To the extent a compass has been incorporated in prior art seismic units, the compass has been housed in a separate package from other components, such as the geophones. Of course, many prior art units do not determine a unit's directional orientation at all and thus do not incorporate a compass. Rather, only vertical orientation data is acquired using a tilt meter. When the self-contained multidirectional sensor unit of the invention incorporates both a compass used in conjunction with a tilt meter, the specific three dimensional orientation of the unit can be determined. None of the prior art devices incorporate the combination of both a compass and a tilt meter on board a single, self-contained unit package, particularly for this function.

In another aspect of the invention, the unit is activated prior to transportation out to the field and deactivated once retrieved, such that it is continuously acquiring data from before the time of deployment to after the time of retrieval. Likewise in one embodiment, the unit begins recording data prior to deployment. Systems that are activated and begin recording before deployment are thereby stabilized prior to the time when signal detection is desired. This minimizes the likelihood that an altered state in electronics operation will disrupt signal detection and recording or effect clock synchronization.

In another aspect of the invention, the seismic data recording device includes wrap around memory and continuously records, even when not in use. This obviates the need for initiation or start instructions, ensures that the unit is stabilized at the desired recording times, and serves to back-up data from prior recordings until such time as the prior data is written over. As long as the clock is synchronized, such a recording device is ready for deployment at any time. Furthermore, routine operations such as data collection, quality control tests and battery charging can take place without interrupting recording.

Continuous operation is also desirable as an element of an inertial navigation system incorporated in the seismic unit and used to measure the unit's x, y and z position information as the unit is transported from an initial position, such as a storage location, to a deployment position out in the field. An inertial navigation system may include sensors, such as accelerometers to track x, y and z position information, as well as a compass and tilt meter to determine orientations. Such a system can be used to determine the deployment location of a unit in the field.

Each unit may include a communications portal to permit the unit to interface with a master control station via the communications portal, typically after the unit has been retrieved from deployment. Through the portal, information recorded on the unit can be downloaded, the unit batteries can be recharged, quality control checks on the unit can be conducted, recording can be re-initiated and the unit can be reactivated without the need to open or disassemble the unit.

Each unit may include a unique identification means, such as a radio frequency identification (RFID) tag or similar identification indicia to permit tracking of the individual units as they are handled. Likewise, each unit may include a Global Positioning System ("GPS"). Since the individual units are self-contained, the location information, in association with the identification indicia allows the units to be randomly handled and stored, but permits data from multiple units to be

6

retrieved and sequentially ordered according to the location of the unit during a shot cycle. Thus, the need to keep units in sequential order is obviated. Units that might have been adjacent one another on a receiver line need not be retrieved in order or stored next to one another.

BRIEF DESCRIPTION OF THE DRAWINGS

FIG. 1 is a cut-away top view of the seismic recorder unit of the current invention.

FIG. 2 is a front side view of the unit of FIG. 1.

FIG. 3 is a back side view of the unit of FIG. 1.

FIG. 4 is a top view of the unit of FIG. 1.

DESCRIPTION OF THE PREFERRED EMBODIMENTS

In the detailed description of the invention, like numerals are employed to designate like parts throughout. Various items of equipment, such as fasteners, fittings, etc., may be omitted to simplify the description. However, those skilled in the art will realize that such conventional equipment can be employed as desired.

With reference to FIG. 1, there is shown a seismic data collection system or pod 10 of the invention. Pod 10 is comprised of a case 12 having a wall 14 defining an internal, compartment 16. Preferably, case 12 is sealed to prevent water, dust or other debris from migrating into compartment 16. Disposed within compartment 16 is at least one geophone 18, a clock 20, a power source 22, a control mechanism 23 and a seismic data recorder 24. In the embodiment, pod 10 is self-contained such that power source 22 meets all of the power requirements of pod 10. Likewise, control mechanism 23 provides all control functions for pod 10 eliminating the need for external control communications. In an alternative embodiment, power source 22 may be attached externally to case 12 as described below.

Those skilled in the art will appreciate that pod 10 is a self-contained seismic data collection system which requires no external communication or control in order to record seismic signals. It will be further noted that geophone 18 is internally mounted within pod 10 and thus requires no external wiring or connection. It has been determined that utilizing a compact case and positioning geophone 18 adjacent the casing wall, geophone 18 can be effectively coupled to the earth such that seismic data transmitted through pod 10 to geophone 18 is not corrupted by interference. Unless specifically indicated, all references to geophones utilized in the invention include conventional geophones as well as other known devices for detecting seismic wave activity or directional sensors, including without limitation, accelerometers, and references to accelerometers likewise include other directional sensors, including, without limitation, geophones.

In another embodiment of the invention, it has been found advantageous to utilize four geophones 18a, 18b, 18c, 18d positioned in a tetrahedral configuration such that each geophone measures data in multiple planes. In a standard three dimensions configuration, three geophones are positioned 90° apart from each other and each geophone measures signal in a single x, y or z plane. In a four geophone configuration, the geophones are oriented perpendicular to the plane of the tetrahedral faces so that each geophone measures portions of multiple planes in the x, y, z coordinate system. For example, one geophone may measure seismic data in the x-plane and z-plane. Geophone configurations of four or more geophones

are desirable because they provide for redundancy in the seismic unit in the event of failure of a geophone in a particular plane.

Another embodiment of the invention utilizes a geophone **19** disposed within pod **10** as a driven power source to gauge the degree of coupling of pod **10** with the earth. Those skilled in the art will understand that the physical coupling between a seismic unit and the earth has become one of the primary concerns in the seismic data collection industry. The invention incorporates a driven geophone to test this coupling. Specifically, rather than simply utilizing a geophone to detect energy, it has been found that a geophone can be utilized as a power source to introduce energy, i.e., vibrations, into pod **10**. In other words, a geophone within pod **10** can be driven thereby causing pod **10** to shake. Such a driven geophone used in conjunction with the other geophones on board can be used to determine the degree of physical coupling between pod **10** and the earth. If pod **10** is well coupled with the earth, the vibrational energy generated by the geophone will be transmitted through the pod's coupling structure, such as spike **52**, and dispersed within the earth. In such case, the other on-board geophones used for detecting vibrational energy would detect energy at a first low level. On the other hand, if there is not good coupling between pod **10** and the earth, the generated vibrational energy will not be transmitted into the earth. In such case, the other on-board geophones used for detecting vibrational energy would detect energy at a second level much higher than the first level.

None of the prior art seismic units teach an on-board system to test the degree of coupling between the unit and the earth. This is true in part because none of the prior art devices comprise a self-contained seismic recording unit as described herein. Rather, the prior art units separate the geophone package from the electronics of the rest of the unit. In such case, it would be impractical to include a power source, along with the electronics to control the power source, in a distributed, separate geophone package. The above described system is desirable because it can be utilized in a system with as few as two geophones, where one geophone functions as an energy source and the other geophone functions as an energy receiver. Further, such a system permits the use of at least one geophone for a dual purpose, i.e., the geophone can be used to generate energy during coupling tests but can otherwise be used in a detection mode to detect seismic during seismic exploration. Of course, to the extent a geophone is dedicated only for use as an energy source, it need not be positioned with the other seismic detection geophones in the unit. Thus, for example, a three geophone package to measure seismic energy in the x, y and z planes might be positioned within pod **10** to maximize their ability to detect seismic energy, such as adjacent the base of pod **10**, while a fourth geophone dedicated as an energy source might be positioned within pod **10** to maximize distributions of vibrational energy within pod **10**, such as near the top of pod **10**.

In one important aspect of the invention, clock **20** is a rubidium clock. Heretofore, rubidium clocks have not been used in seismic exploration due in part to the expense when compared to traditional crystal driven clocks. However, because the pod **10** of the invention is intended to operate effectively independent of its orientation, it is necessary to utilize a clock that is not susceptible to orientation effects which can inhibit operation of traditional prior art crystal clocks. Furthermore, rubidium clocks are less susceptible to temperature and gravitational effects that can inhibit operation of prior art clocks.

Gravitational effects on clock **20** can also be minimized through use of a mechanically gimballed platform **21** that

rotates to maintain clock **20** in a more optimal orientation for performance. Preferably, gimballed platform **21** can rotate in at least three degrees of freedom, although gimballed platform **21** may have fewer degrees of freedom and still be utilized for the desired purpose. This is an improvement over prior art seismic units which have not utilized gimballed clock platforms at all.

Unit **10** may also include tilt meter **25**. Tilt meter **25** and the data generated therefrom may serve several different purposes, including without limitation, correction of clock data or for vertical orientation determination. Furthermore, such tilt meter data is measured as a function of time. Thus, preferably, the tilt meter data is associated with a data set in a time continuous fashion such that a data set generated at a particular time is associated with tilt meter data generated at that same time. While prior art seismic units have not incorporated tilt meters in a single, self-contained multidirectional sensor unit, to the extent orientation corrections have been made to seismic data generated from prior art units, such corrections have been made from orientation data generated at the beginning of a shot cycle to correct all of the seismic data generated during the shot cycle. This can result in inaccuracies to the extent the orientation of the seismic unit is altered during a shot cycle or deployment period. In one embodiment, all such tilt meter corrections are made on-board the unit, preferably in real time.

In this same vein, unit **10** may include a compass **27**, which, heretofore has not been utilized in a single, self-contained multidirectional sensor unit. Compass **27** and the data generated therefrom may be used to provide directional frame of reference data for each individual unit relative to the frame of reference for the overall survey. Furthermore, when used in conjunction with tilt meter data, the specific three-dimensional orientation of a unit can be determined such that seismic data accuracy can be further improved.

Power source **22** is preferably a lithium ion battery. To the extent prior art seismometer systems have utilized on-board batteries, as opposed to external cabling to supply power, the prior art batteries have been lead-acid, alkaline or non-rechargeable batteries. None of the prior art systems have utilized lithium ion batteries. Furthermore, because of the sealed, self-contained nature of the pod of the invention, it is desirable to utilize a battery that does not vent fumes, such as a lithium ion type battery. In an alternative embodiment, power source **22** may incorporate a fuel cell or solar cell attached externally to case **12**. Of course, while such power source components are not contained within case **12**, for purposes of the invention, pod **10** is still self-contained in the sense that it operates as a stand alone unit without communication, control signals or power from a source removed from the pod.

In FIGS. **2**, **3**, and **4**, the exterior of pod **10** is shown. Wall **14** defining case **12** may include a first plate **26** and a second plate **28** jointed together along their peripheries by a portion of wall **14**. Each plate defines an external surface **50**. While plates **26** and **28** are disk shaped in the illustrated embodiment such that pod **10** has an overall wheel shape, pod **10** can be of any shape so long as it functions in accordance herewith. The external surface **50** may be provided with projections **51**, such as ridges or grooves, to enhance coupling between pod **10** and the earth. In the embodiment shown in FIG. **4**, the projections **51** form a chevron pattern on surface **50**. More pronounced projections, such as spikes **52**, may be provided to prevent movement of pod **10** once it is deployed and improve coupling.

Each unit may include a unique identification means, such as a radio frequency identification (RFID) tag **40** or similar

identification indicia to permit tracking of the individual units as they are handled during deployment and retrieval. Likewise, each unit may include a GPS transducer **42** which permits the unit's location to be determined (to the extent a unit is deployed in a location in which GPS is effective).

FIG. **1** also shows a radio antennae **44** which is communication with a radio unit **45** disposed within case **12**.

A connector **46** for permitting communication with pod **10** may also be disposed on case **12**. Such communication may occur when pod **10** is in storage at a central command unit or even to the extent data is simply retrieved by an operator who travels out to the pod's deployment location. Connector **46** may be a standard pin connector or may be an infrared or similar connector that requires no hard wiring in order to communicate with pod **10**. Via connector **46**, pod **10** may be serviced without removing one of plates **26**, **28** or otherwise opening case **12**. Specifically, connector **46** permits quality control tests to be run, recorded seismic data to be extracted, clock **20** to be synchronized and power source **22** to be recharged. A sealing connector cap **47** may also be provided to protect connector **46**. For under water uses or other wet environments, connector cap **47** is preferably water tight. Utilizing such a connector cap **47**, connector **46** may be any standard connector that satisfies the desired functions of the pod and need not be of the type normally required of external connectors subjected to extreme or corrosive environments.

One function of the seismic data recording unit of the invention is the continuous operation of the unit. In this aspect of the invention, data acquisition is initiated prior to positioning of the unit on the earth's surface, i.e., prior to deployment. For example, units may be activated at a central location prior to trucking them out to the field. Systems that are activated and begin acquiring data prior to deployment are thereby stabilized prior to the time synchronization and seismic data recording are desired. This minimizes the likelihood that an altered state in electronics operation will have an effect of data integrity.

In a similar embodiment, data recording is initiated prior to positioning along a receiver line. Again, this permits units to stabilize prior to the time synchronization and seismic data recording are desired. To this end, one component of system stabilization is clock stabilization. Of the various components of the system, it is well known that clocks typically take a long time to stabilize. Thus, in one embodiment of the invention, whether the unit is continuously detecting data or continuously recording data, the clock always remains on.

In either of the preceding two methods, the unit can be utilized in several cycles of deployment and retrieval without interrupting the continuous operation of the unit. Thus, for example, prior to deployment, recording is initiated. The device is deployed, retrieved and redeployed, all while recording is continued. As long as memory is sufficient, this continuous recording during multiple cycles of deployment and redeployment can be maintained.

In this regard, to the extent the seismic data unit includes wrap around memory, it can continuously record even when not in use in seismic detection. Thus, in addition to the advantages described above, initiation or start instructions become unnecessary. Further, continuous recording utilizing wrap around memory functions as a back-up for data acquired from prior recordings until such time as the prior data is written over. An additional advantage is that the device is ready for deployment at any time as long as the clock is synchronized.

To the extent recording is continued after a unit has been retrieved, routine operations such as data retrieval, quality control tests and battery charging can take place without interrupting recording. One benefit of such a system is that the

device can be utilized to record quality control test data rather than seismic data when conducting quality control tests. In other words, the data input changes from seismic data to quality control data. Once quality control is complete, the device may resume recording seismic data or other desired data, such as data related to position and timing.

While "continuous" unit operation has been described temporally in one embodiment as setting operation parameters to initiate operation prior to deployment of the unit, for purposes of the meaning of "continuous" as used herein, the time period of unit operation may simply be initiated prior to a shot and continue through a series of shots or shot cycles and may also include continued recording of a unit through a series of shots or shot cycles. In another embodiment, while continuously operating, parameters may be set to intermittently record at pre-set, specified times.

The above described continuous operation of the seismic units of the invention is particularly suited for use with a unique position determination method of the invention. Specifically, a unit's x, y and z position information is recorded as the unit is transported from an initial position, such as a storage location, to a deployment position out in the field. The positional information may be determined using an inertial navigation system that measures movement in each of the x, y and z dimensions as well as angular movement around each x, y and z axis. In other words, the system measures the six degrees of freedom of the unit as it travels from the initial location to the deployment position, and utilizes such measurement information to determine the location of the deployment position. In the preferred embodiment, such x, y and z dimensional information can be determined utilizing accelerometers. Angular orientation, i.e., tilt and direction, information can be determined utilizing a tilt meter and a compass or other orientation devices, such as gyroscopes. In one embodiment of the invention, three accelerometers and three gyroscopes are utilized to generate the inertial navigation data used to determine the unit's deployment position.

In any event, by combining accelerometer and the tilt and direction orientation information as a function of time with the unit's initial position and velocity at the time of initial deployment, the travel path of the unit and hence the deployment location of the unit, can be determined. Time sampling will occur at appropriate intervals to yield the accuracy needed. Time sampling between various measurement components may vary. For example, data from the compass, used to measure direction, and the tilt meter, used to measure tilt, may be sampled more slowly than data from the accelerometers. Heretofore, no other seismic unit has utilized one or more accelerometers to determine location in this way. In this regard, the method and system replaces the need to determine location utilizing other techniques, such as through GPS or the like.

Because a unit is already recording data at the time of its transportation to and deployment in the field, x, y and z positional information is easily recorded on the unit and becomes part of the unit's complete data record.

To the extent clock **20** is a crystal clock, one method of the invention is to make clock corrections to compensate for aging of the clock's crystals. Specifically, it has been determined that seismic data can be effected by the aging of crystals within a unit's crystal clock.

Typically, the aging curve for a given crystal will be logarithmic for an initial period of time and gradually transition into a more linear curve over an extended period of time. As such, the curve has a significant slope at the beginning of the aging process and a more linear, flat slope at as the aging process continues over time. In this regard, a seismic unit will

11

tend to have more crystal aging at the beginning of a deployment period. In any event, prior to deployment, a characterization curve for a clock's crystal can be determined by plotting crystal aging vs. time over an extended period of days, such as fifteen to twenty days. In operation, the crystal frequency can be measured at the time of deployment and at the end of deployment. Utilizing this information, the applicable portion of the aging curve can be identified and the seismic data collected over the period can be adjusted accordingly.

Of course, one process to minimize the effects of crystal aging is to preage a clock's crystals prior to deployment of the unit. This is somewhat equivalent to initiating operation of the unit prior to deployment in order to permit the unit to stabilize as described above. By preaging crystals, the exponential portion of the characterization curve can be avoided such that the correction information is simply linear in nature. In other words, preaging stabilizes the aging slope and simplifies

In this regard, each time a seismic unit is powered off and back on, the clock's crystals must be re-characterized. However, over multiple cycles of operation, the linear portion of the aging curve, i.e., crystal aging stabilization, is reached more quickly. Notwithstanding the foregoing, whether crystals are preaged or not, none of the prior art devices or seismic data processing techniques correct for crystal aging as described herein.

While certain features and embodiments of the invention have been described in detail herein, it will be readily understood that the invention encompasses all modifications and enhancements within the scope and spirit of the following claims.

What is claimed is:

1. A seismic data collection unit comprising:
 - a. a fully enclosed, single case formed of a housing, said case having a wall defining an internal compartment within said housing;
 - b. at least one geophone internally fixed within said housing;
 - c. a clock disposed within said housing;
 - d. a power source disposed within said housing; and
 - e. a seismic data recorder disposed within said housing;
 - f. wherein each of said elements b-e include an electrical connection and all electrical connections between any elements b-e are contained within said housing; and
 - g. wherein said geophone is coupled to said seismic data recorder to permit seismic signals detected by said geophones to be recorded on said seismic data recorder,
 - h. wherein the single case comprises a first plate having a first periphery and a second plate having a second periphery, wherein the plates are joined along their peripheries by a circular wall.
2. The unit of claim 1, wherein said unit is self contained and requires no external communications or controls during recording.
3. The unit of claim 1, wherein the case is watertight.
4. The unit of claim 1, wherein said at least one geophone is disposed adjacent a plate.
5. A seismic data collection unit comprising:
 - a. a fully enclosed, single case formed of a housing, said single case having a first plate having a first periphery and a second plate having a second periphery, wherein the plates are joined along their peripheries by a circular wall, said wall defining an internal compartment within said housing;
 - b. at least one geophone internally fixed within said housing;
 - c. a clock disposed within said housing;

12

d. a power source; and

e. a seismic data recorder disposed within said housing.

6. The unit of claim 5, wherein said unit is self contained and requires no external communications or controls during recording.

7. The unit of claim 5, wherein , wherein each of said elements b-c include an electrical connection and all electrical connections between any elements b-c are contained within said housing.

8. The unit of claim 5, wherein the power source includes a fuel cell attached to the case.

9. The unit of claim 5, wherein the power source includes a solar cell attached to the case.

10. The unit of claim 1, wherein the case defines an external surface, and the external surface is provided with ridges to enhance coupling of unit with the earth.

11. The unit of claim 1, wherein the case defines an external surface, and the external surface is provided with at least one spike to enhance coupling of unit with the earth.

12. The unit of claim 1, further comprising

- a. three geophones disposed within said case; and
- b. a compass.

13. The unit of claim 1, wherein the geophone is a multi-component geophone capable of measuring seismic signals in at least two directions angularly oriented to one another.

14. The unit of claim 1, further comprising a GPS location transducer.

15. The unit of claim 1, further comprising a radio unit.

16. The unit of claim 1, further comprising an external connector in electrical communication with at least one of said geophone, clock, power source and seismic recorder, said connector extending through the wall of said case and disposed within said wall so as to be set in from the external surface of said wall.

17. The unit of claim 16, further comprising a water tight, pressure resistant cap disposed over said external connector.

18. The unit of claim 1, further comprising an internal control mechanism for controlling all functions of the unit while deployed.

19. The seismic data collection unit of claim 5, further comprising:

- a. at least four seismic data geophones disposed within said case, wherein at least three of said geophones are disposed adjacent one another and at least one geophone is disposed in a location within said case removed from said other geophones.

20. The seismic data collection unit of claim 5, further comprising a case in which the at least four seismic data geophones are disposed, wherein said at least three geophones are disposed in said case to maximize detection of seismic energy and said at least one geophone is disposed in said case to maximize vibration of said case by said removed geophone.

21. A seismic data collection unit comprising:

- a. a fully enclosed, single case formed of a housing, said single case having a first plate having a first periphery and a second plate having a second periphery, wherein the plates are joined along their peripheries by a circular wall, said wall defining an internal compartment within said housing;
- b. at least one geophone internally fixed within said housing;
- c. a clock disposed within said housing;
- d. a power source disposed within said housing;
- e. positional electronics disposed within said housing;
- f. orientation electronics disposed within said housing; and
- g. a seismic data recorder disposed within said housing;

- h. wherein each of said elements b-g include an electrical connection and all electrical connections between any elements b-g are contained within said housing.
22. A seismic data collection unit comprising:
- a. a non-spherical pod formed of a single housing, said pod comprising a wall defining an internal compartment within said single housing;
 - b. at least one geophone internally fixed within said internal compartment;
 - c. a clock disposed within said internal compartment;
 - d. a power source disposed within said internal compartment; and
 - e. a seismic data recorder disposed within said internal compartment;
 - f. wherein each of said elements b-e include an electrical connection and all electrical connections between any elements b-e are contained within said internal compartment; and
 - g. wherein the at least one geophone is coupled to the seismic data recorder to permit seismic signals detected by said geophones to be recorded on said seismic data recorder.
23. The seismic data collection unit of claim 22, wherein said seismic data collection unit is self contained and requires no external communications or controls during recording.
24. The seismic data collection unit of claim 22, wherein said pod is watertight.
25. The seismic data collection unit of claim 22, wherein a portion of an external surface of the pod comprises at least one projection to enhance coupling of the seismic data collection unit with the earth.
26. The seismic data collection unit of claim 25, wherein the at least one projection is at least one spike, at least one ridge, or at least one groove.
27. The seismic data collection unit of claim 22, further comprising: a compass; and at least two additional geophones disposed within said pod.
28. The seismic data collection unit of claim 22, wherein the at least one geophone is a multi-component geophone capable of measuring seismic signals in at least two directions angularly oriented to one another.
29. The seismic data collection unit of claim 22, wherein a portion of the pod has a circular shape.
30. The seismic data collection unit of claim 22, wherein a portion of the pod has a non-circular shape.
31. The seismic data collection unit of claim 22, further comprising a GPS location transducer.
32. The seismic data collection unit of claim 22, further comprising a radio unit.
33. The seismic data collection unit of claim 22, further comprising an external connector, wherein the external connector is disposed in electrical communication with the at least one geophone, the clock, the power source and the seismic data recorder, and wherein the external connector extends through a portion of the wall of the single case.
34. The seismic data collection unit of claim 33, further comprising a water tight, pressure resistant cap disposed over said external connector.

35. The seismic data collection unit of claim 22, wherein the power source comprises a fuel cell or a solar cell.
36. The seismic data collection unit of claim 22, wherein: the at least one geophone comprises at least four seismic data geophones disposed within said case, at least three seismic data geophones of said at least four seismic data geophones are disposed proximate to one another, and at least one seismic data geophone of said at least four seismic data geophones is disposed at a location within said internal compartment that is removed from the at least three seismic data geophones that are disposed proximate to each other.
37. The seismic data collection unit of claim 36, wherein the at least three seismic data geophones that are disposed proximate to each other are configured to maximize detection of seismic energy, and wherein the at least one seismic data geophone that is removed from the at least three seismic data geophones is configured to mechanically vibrate the pod.
38. The seismic data collection unit of claim 22, further comprising a tilt meter disposed in the internal compartment.
39. The seismic data collection unit of claim 22, wherein the pod comprises at least one internal partition disposed within the internal compartment.
40. The seismic data collection unit of claim 39, wherein the at least one partition is disposed proximate to the power source, and wherein the at least one partition separates the power source from other components in the pod.
41. The seismic data collection unit of claim 39, wherein the at least one partition is disposed proximate to the seismic data recorder, and wherein the at least one partition separates the seismic data recorder from other components in the pod.
42. The seismic data collection unit of claim 39, wherein the at least one partition is disposed proximate to the seismic data recorder, and wherein the at least one partition separates the seismic data recorder from the at least one geophone.
43. The seismic data collection unit of claim 39, wherein the at least one internal partition divides the internal compartment into multiple compartments.
44. The unit of claim 1, wherein said geophone is configured to vibrate said housing.
45. The unit of claim 1, wherein said geophone is a first geophone, further comprising: a second geophone configured to vibrate the case.
46. The unit of claim 5, wherein said geophone is configured to vibrate said housing.
47. The unit of claim 5, wherein said geophone is a first geophone, further comprising: a second geophone configured to vibrate the case.
48. The unit of claim 21, wherein at least one of said at least one geophone is configured to vibrate said housing.
49. The unit of claim 22, wherein at least one of said at least one geophone is configured to vibrate said pod.

UNITED STATES PATENT AND TRADEMARK OFFICE
CERTIFICATE OF CORRECTION

PATENT NO. : RE45,268 E
APPLICATION NO. : 13/952135
DATED : December 2, 2014
INVENTOR(S) : Clifford H. Ray et al.

Page 1 of 1

It is certified that error appears in the above-identified patent and that said Letters Patent is hereby corrected as shown below:

On the Title Page

Item [60], insert:

--Reissue of application No. 12/547,478, filed on Aug. 25, 2009, now Pat. No. 7,986,589, which is a divisional of application No. 12/220,518, filed on Jul. 25, 2008, now Pat. No. 7,688,047, which is a divisional of application No. 10/766,253, filed on Jan. 28, 2004, now Pat. No. 7,561,493, which is a continuation-in-part of application No. 10/448,547, filed May 30, 2003, now Pat. No. 7,310,287.--

In the Specification

Column 1, Line 13 insert:

--This application is a reissue of U.S. patent application Ser. No. 12/547,478, filed Aug. 25, 2009 and issued on Jul. 26, 2011 as U.S. Pat. No. 7,986,589, which claims priority under 35 U.S.C. §121 as a divisional of U.S. patent application Ser. No. 12/220,518, filed Jul. 25, 2008, and issued Feb. 23, 2010 as U.S. Pat. No. 7,668,047, which claims priority under 35 U.S.C. §121 as a divisional of U.S. patent application Ser. No. 10/766,253, filed Jan. 28, 2004, and issued Jul. 14, 2009 as U.S. Pat. No. 7,561,493, which claims priority under 35 U.S.C. §120 as a continuation-in-part of U.S. patent application Ser. No. 10/448,547, filed on May 30, 2003, and issued as U.S. Pat. No. 7,310,287 on Dec. 18, 2007.--

Signed and Sealed this
Thirty-first Day of October, 2017



Joseph Matal

*Performing the Functions and Duties of the
Under Secretary of Commerce for Intellectual Property and
Director of the United States Patent and Trademark Office*

(12) **INTER PARTES REVIEW CERTIFICATE** (2884th)

United States Patent
Ray et al.

(10) **Number:** **US RE45,268 K1**
(45) **Certificate Issued:** **Nov. 1, 2022**

(54) **APPARATUS FOR SEISMIC DATA
ACQUISITION**

(71) **Applicants: Clifford H. Ray; Glenn D. Fisseler;
Hal B. Haygood**

(72) **Inventors: Clifford H. Ray; Glenn D. Fisseler;
Hal B. Haygood**

(73) **Assignee: MAGSEIS FF LLC**

Trial Number:

IPR2018-00960 filed Apr. 27, 2018

Inter Partes Review Certificate for:

Patent No.: **RE45,268**
Issued: **Dec. 2, 2014**
Appl. No.: **13/952,135**
Filed: **Jul. 26, 2013**

The results of IPR2018-00960 are reflected in this inter partes review certificate under 35 U.S.C. 318(b).

INTER PARTES REVIEW CERTIFICATE
U.S. Patent RE45,268 K1
Trial No. IPR2018-00960
Certificate Issued Nov. 1, 2022

1

2

AS A RESULT OF THE INTER PARTES
REVIEW PROCEEDING, IT HAS BEEN
DETERMINED THAT:

Claims 1-3, 5-7, 10, 12, 13, 15-18, 21-30, 32-34 and ⁵
38-43 are cancelled.

* * * * *