

US00RE45244E

(19) **United States**
(12) **Reissued Patent**
Schetky et al.

(10) **Patent Number:** **US RE45,244 E**
(45) **Date of Reissued Patent:** ***Nov. 18, 2014**

(54) **EXPANDABLE TUBING AND METHOD**

(56)

References Cited

(75) Inventors: **L. McD. Schetky**, Camden, ME (US);
Craig D. Johnson, Montgomery, TX
(US); **Matthew R. Hackworth**,
Pearland, TX (US); **Patrick W.**
Bixenman, Houston, TX (US); **Peter**
Besselink, Enschede (NL)

U.S. PATENT DOCUMENTS

261,252 A	7/1882	Olmsted
380,419 A	4/1888	Bignall
997,191 A	7/1911	Hogarth
1,135,809 A	4/1915	Jones
1,229,437 A	6/1917	Foster
1,233,888 A	7/1917	Leonard
1,276,213 A	8/1918	Hare
1,301,285 A	4/1919	Leonard
1,314,600 A	9/1919	McCahey
1,647,907 A	11/1927	Doty

(73) Assignee: **Halliburton Energy Services, Inc.**,
Houston, TX (US)

(*) Notice: This patent is subject to a terminal dis-
claimer.

(Continued)

FOREIGN PATENT DOCUMENTS

(21) Appl. No.: **12/872,203**

AU	784777	8/2002
AU	2006202182	6/2006

(22) Filed: **Aug. 31, 2010**

(Continued)

Related U.S. Patent Documents

Reissue of:

(64) Patent No.: **6,799,637**
Issued: **Oct. 5, 2004**
Appl. No.: **09/973,442**
Filed: **Oct. 9, 2001**

OTHER PUBLICATIONS

Gravel Pack Systems: Mini-Beta Gravel Pack System, Baker Oil
Tools, pp. 12-13, (Undated).

(Continued)

U.S. Applications:

(60) Provisional application No. 60/242,276, filed on Oct.
20, 2000, provisional application No. 60/263,941,
filed on Jan. 24, 2001.

Primary Examiner — William P Neuder

(74) *Attorney, Agent, or Firm* — McDermott Will & Emery
LLP; Scott Richardson

(51) **Int. Cl.**
E21B 43/10 (2006.01)

(52) **U.S. Cl.**
USPC **166/384**; 166/207; 166/230

(58) **Field of Classification Search**
USPC 166/380, 382, 207, 227
See application file for complete search history.

(57)

ABSTRACT

An apparatus suitable for use in a wellbore comprises an
expandable bistable device. An exemplary device has a plu-
rality of bistable cells formed into a tubular shape. Each
bistable cell comprises at least two elongated members that
are connected to each other at their ends. The device is stable
in a first configuration and a second configuration.

10 Claims, 17 Drawing Sheets

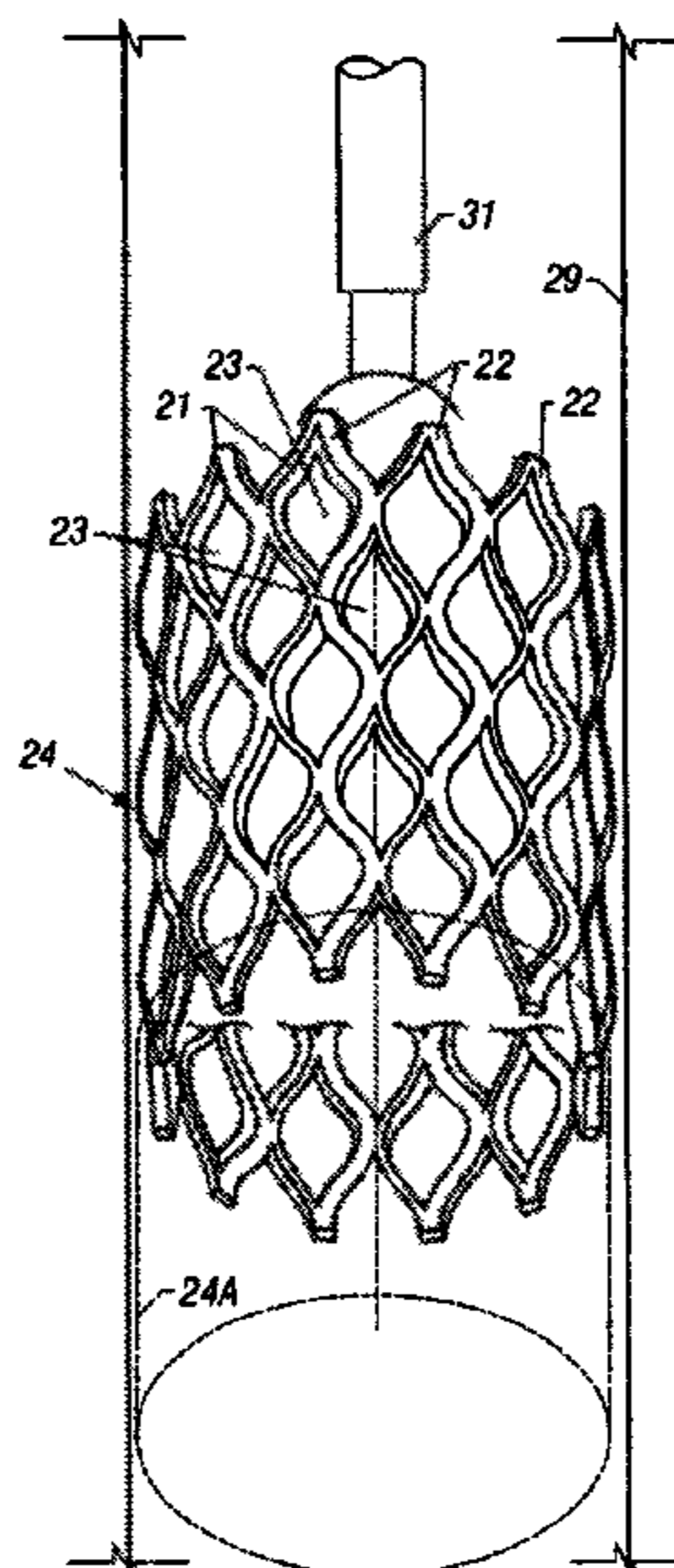

(56)

References Cited

U.S. PATENT DOCUMENTS

1,945,079 A	1/1934	Riemenschneider	4,832,121 A	5/1989	Anderson
1,981,525 A	11/1934	Price	4,866,062 A	9/1989	Toth
2,016,683 A	10/1935	Moore	4,874,327 A	10/1989	Ip
2,050,128 A	8/1936	Schlumberger	4,886,062 A	12/1989	Wiktor
2,171,840 A	9/1939	Armentrout	4,945,991 A	8/1990	Jones
2,217,708 A	10/1940	Scaramucci	4,950,258 A	8/1990	Kawai
2,220,205 A	11/1940	Buckley	4,969,890 A	11/1990	Sugita
2,371,385 A	3/1945	Eckel	4,976,142 A	12/1990	Perales
2,530,966 A	11/1950	Huber	4,990,155 A	2/1991	Wilkoff
2,677,466 A	5/1954	Lowe	4,994,071 A	2/1991	MacGregor
2,696,169 A	12/1954	Lassiter	5,102,417 A	4/1992	Palmaz
2,760,581 A	8/1956	Johnston	5,104,404 A	4/1992	Wolff
2,769,655 A	11/1956	Holmes	5,107,927 A	4/1992	Whiteley
2,812,025 A	11/1957	Teague et al.	5,119,373 A	6/1992	Fredricsson
2,835,328 A	5/1958	Thompson	5,141,360 A	8/1992	Zeman
2,990,017 A	6/1961	Powers	5,147,370 A	9/1992	McNamara
3,069,125 A	12/1962	Hewitt	5,156,220 A	10/1992	Forehand
3,179,168 A	4/1965	Vincent	5,163,321 A	11/1992	Perales
3,203,451 A	8/1965	Vincent	5,174,379 A	12/1992	Whiteley
3,253,842 A	5/1966	Rabe	5,186,255 A	2/1993	Corey
3,297,092 A	1/1967	Jennings	5,192,307 A	3/1993	Wall
3,353,599 A	11/1967	Swift	5,195,984 A	3/1993	Schatz
3,358,492 A	12/1967	Richter	5,197,978 A	3/1993	Hess
3,389,752 A	6/1968	Lebourg	5,211,241 A	5/1993	Mashaw, Jr. et al.
3,414,055 A	12/1968	Vogt	5,226,913 A	7/1993	Pinchuk
3,415,321 A	12/1968	Venghiattis	5,234,448 A	8/1993	Wholey
3,419,080 A	12/1968	Lebourg	5,243,190 A	9/1993	Bandy
3,463,247 A	8/1969	Klein	5,282,823 A	2/1994	Schwartz
3,482,629 A	12/1969	Suman	5,318,121 A	6/1994	Brockman
3,489,220 A	1/1970	Kinley	5,329,998 A	7/1994	King
3,507,340 A	4/1970	Voetter	5,337,823 A	8/1994	Nobileau
3,508,587 A	4/1970	Mauch	5,348,095 A	9/1994	Worrall et al.
3,556,219 A	1/1971	Meldau	5,354,308 A	10/1994	Simon
3,561,529 A	2/1971	Owen	5,355,948 A	10/1994	Sparlin
3,604,732 A	9/1971	Malone	5,355,949 A	10/1994	Sparlin
3,657,744 A	4/1972	Ersek	5,355,953 A	10/1994	Shy
3,672,705 A	6/1972	Rush	5,366,012 A	11/1994	Lohbeck
3,692,114 A	9/1972	Murphey, Jr. et al.	5,377,104 A	12/1994	Sorrells
3,785,193 A	1/1974	Kinley	5,377,823 A	1/1995	Steen et al.
3,816,894 A	6/1974	Howard	5,383,892 A	1/1995	Cardon
3,864,970 A	2/1975	Bell	5,383,926 A	1/1995	Lock
3,898,717 A	8/1975	Schwartz	5,396,957 A	3/1995	Surjaatmadja
3,913,676 A	10/1975	Barbee, Jr. et al.	5,397,355 A	3/1995	Marin
3,926,409 A	12/1975	Abney	5,403,341 A	4/1995	Solar
3,963,076 A	6/1976	Winslow	5,411,507 A	5/1995	Heckele
4,064,938 A	12/1977	Fast	5,419,760 A	5/1995	Narciso, Jr.
4,065,953 A	1/1978	Frentzen	5,449,373 A	9/1995	Pinchasik
4,185,856 A	1/1980	McCaskill	5,449,382 A	9/1995	Dayton
4,253,522 A	3/1981	Setterberg, Jr.	5,450,898 A	9/1995	Sparlin
4,295,527 A	10/1981	Russe	5,456,319 A	10/1995	Schmidt
4,309,891 A	1/1982	Pogonowski	5,492,175 A	2/1996	El-Rabaa et al.
4,337,969 A	7/1982	Escaron	5,496,365 A	3/1996	Sgro
4,375,164 A	3/1983	Dodge	5,500,013 A	3/1996	Buscemi
4,401,158 A	8/1983	Spencer	5,515,915 A	5/1996	Jones
4,495,997 A	1/1985	Scott	5,545,208 A	8/1996	Wolff
4,541,486 A	9/1985	Wetzel	5,545,210 A	8/1996	Hess
4,553,595 A	11/1985	Huang	5,554,183 A	9/1996	Nazari
4,558,219 A	12/1985	LeBlanc	5,556,413 A	9/1996	Lam
4,558,742 A	12/1985	Huang	5,562,690 A	10/1996	Green
4,566,538 A	1/1986	Peterson	5,562,697 A	10/1996	Christiansen
4,578,608 A	3/1986	Mech	5,576,485 A	11/1996	Serata
4,580,568 A	4/1986	Gianturco	5,601,593 A	2/1997	Freitag
4,600,037 A	7/1986	Hatten	5,618,299 A	4/1997	Khosravi
4,606,408 A	8/1986	Zunkel	5,628,787 A	5/1997	Mayer
4,626,129 A	12/1986	Kothmann	5,641,023 A	6/1997	Ross
4,655,771 A	4/1987	Wallsten	5,643,314 A	7/1997	Carpenter
4,657,079 A	4/1987	Nagaoka	5,663,805 A	9/1997	Asai
4,665,906 A	5/1987	Jervis	5,667,011 A	9/1997	Gill et al.
4,665,918 A	5/1987	Garza	5,670,161 A	9/1997	Healy
4,706,659 A	11/1987	Matthews	5,695,516 A	12/1997	Fischell
4,733,665 A	3/1988	Palmaz	5,697,971 A	12/1997	Fischell
4,739,762 A	4/1988	Palmaz	5,702,419 A	12/1997	Berry
4,740,207 A	4/1988	Kreamer	5,723,781 A	3/1998	Pruett
4,783,995 A	11/1988	Michel	5,725,570 A	3/1998	Heath
4,809,792 A	3/1989	Lynch	5,725,572 A	3/1998	Lam
			5,733,303 A	3/1998	Israel
			5,755,774 A	5/1998	Pinchuk
			5,755,776 A	5/1998	Al-Saadon
			5,776,181 A	7/1998	Lee

(56)

References Cited

U.S. PATENT DOCUMENTS

5,776,183	A	7/1998	Kanesaka	6,281,489	B1	8/2001	Tubel
5,785,120	A	7/1998	Smalley	6,315,040	B1	11/2001	Donnelly
5,806,589	A	9/1998	Lang	6,321,503	B1	11/2001	Warren
5,807,404	A	9/1998	Richter	6,322,109	B1	11/2001	Campbell
5,824,040	A	10/1998	Cox	6,325,148	B1	12/2001	Trahan
5,833,001	A	11/1998	Song	6,327,938	B1	12/2001	Pietras
5,842,516	A	12/1998	Jones	6,328,113	B1	12/2001	Cook
5,861,025	A	1/1999	Boudghene	6,330,911	B1	12/2001	Allen
5,865,073	A	2/1999	Wilson	6,330,918	B1	12/2001	Hosie
5,871,538	A	2/1999	Dereume	6,343,651	B1	2/2002	Bixenman
5,872,901	A	2/1999	Konno	6,360,633	B2	3/2002	Pietras
5,876,449	A	3/1999	Starck	6,368,355	B1	4/2002	Uflacker
5,891,191	A	4/1999	Stinson	6,371,203	B2	4/2002	Frank
5,895,406	A	4/1999	Gray	6,374,565	B1	4/2002	Warren
5,896,928	A	4/1999	Coon	6,378,614	B1	4/2002	Adams
5,899,882	A	5/1999	Waksman	6,382,318	B1	5/2002	Whitlock
5,901,789	A	5/1999	Donnelly et al.	6,415,509	B1	7/2002	Echols
5,913,897	A	6/1999	Corso, Jr. et al.	6,425,444	B1	7/2002	Metcalf
5,918,672	A	7/1999	McConnell	6,431,271	B1 *	8/2002	Thomeer et al. 166/77.51
5,922,020	A	7/1999	Klein	6,446,729	B1	9/2002	Bixenman
5,924,745	A	7/1999	Campbell	6,451,052	B1	9/2002	Burmeister
5,928,280	A	7/1999	Hansen	6,454,493	B1	9/2002	Lohbeck
5,934,376	A	8/1999	Nguyen	6,457,518	B1 *	10/2002	Castano-Mears et al. 166/207
5,957,195	A	9/1999	Bailey	6,457,532	B1	10/2002	Simpson
5,964,296	A	10/1999	Ross	6,464,720	B2	10/2002	Boatman
5,972,018	A	10/1999	Israel	6,478,091	B1 *	11/2002	Gano 166/373
5,984,568	A	11/1999	Lohbeck	6,478,092	B2 *	11/2002	Voll et al. 166/378
5,997,580	A	12/1999	Mastrorio	6,485,524	B2	11/2002	Strecker
6,004,348	A	12/1999	Banas	6,488,702	B1 *	12/2002	Besselink 623/1.15
6,012,522	A	1/2000	Donnelly	6,510,896	B2	1/2003	Bode
6,012,523	A	1/2000	Campbell	6,512,599	B1	1/2003	Hattori
6,013,854	A	1/2000	Moriuchi	6,513,599	B1	2/2003	Bixenman
6,017,362	A	1/2000	Lau	6,520,254	B2	2/2003	Hurst
6,019,789	A	2/2000	Dinh	6,527,047	B1	3/2003	Pietras
6,020,981	A	2/2000	Ogiyama	6,536,291	B1	3/2003	Gysling
6,021,850	A	2/2000	Wood	6,540,777	B2	4/2003	Stenzel
6,022,371	A	2/2000	Killion	6,554,064	B1	4/2003	Restarick
6,027,526	A	2/2000	Limon	6,571,871	B2	6/2003	Lauritzen
6,027,527	A	2/2000	Asano	6,575,245	B2	6/2003	Hurst
6,029,748	A	2/2000	Forsyth et al.	6,578,630	B2	6/2003	Simpson
6,031,637	A	2/2000	Shibata	6,582,461	B1	6/2003	Burmeister
6,042,606	A	3/2000	Frantzen	6,598,678	B1	7/2003	Simpson
6,049,597	A	4/2000	Satake	6,622,797	B2	9/2003	Sivley, IV
6,063,113	A	5/2000	Kavteladze	6,634,431	B2	10/2003	Cook
6,064,491	A	5/2000	Matsumoto	6,648,071	B2	11/2003	Hackworth
6,065,500	A	5/2000	Metcalf	6,669,718	B2	12/2003	Besselink
6,070,671	A	6/2000	Cumming	6,675,891	B2	1/2004	Hailey, Jr. et al.
6,083,258	A	7/2000	Yadav	6,681,854	B2	1/2004	Danos
6,095,242	A	8/2000	Lequang	6,684,951	B2	2/2004	Restarick
6,096,070	A	8/2000	Ragheb	6,688,395	B2	2/2004	Maguire
6,106,548	A	8/2000	Roubin	6,688,397	B2	2/2004	McClurkin
6,112,818	A	9/2000	Campbell	6,695,054	B2	2/2004	Johnson
6,131,662	A	10/2000	Ross	6,695,067	B2	2/2004	Johnson
6,135,208	A	10/2000	Gano	6,706,063		3/2004	Besselink
6,138,776	A	10/2000	Hart	6,719,064	B2	4/2004	Price-Smith et al.
6,142,230	A	11/2000	Smalley	6,722,427	B2	4/2004	Gano
6,147,774	A	11/2000	Hamadani	6,722,441	B2	4/2004	Lauritzen
6,152,599	A	11/2000	Salter, Jr.	6,725,918	B2	4/2004	Gano
6,190,406	B1	2/2001	Duerig	6,725,934	B2	4/2004	Coronado
6,193,744	B1	2/2001	Ehr	6,745,845	B2	6/2004	Cook
6,203,569	B1	3/2001	Wijay	6,755,856	B2	6/2004	Fierens
6,206,911	B1	3/2001	Milo	6,772,836	B2	8/2004	Schetky
6,213,686	B1	4/2001	Baugh	6,789,621	B2	9/2004	Wetzel
6,220,345	B1	4/2001	Jones	6,799,637	B2	10/2004	Schetky
6,220,361	B1	4/2001	Brisco	6,805,196	B2	10/2004	Lawrence
6,227,303	B1	5/2001	Jones	6,817,410	B2	11/2004	Wetzel
6,244,360	B1	6/2001	Steinsland	6,823,943	B2	11/2004	Baugh
6,250,385	B1	6/2001	Montaron	6,848,510	B2	2/2005	Bixenman
6,253,844	B1	7/2001	Walker	6,877,553	B2	4/2005	Cameron
6,253,850	B1	7/2001	Nazzai et al.	6,896,052	B2	5/2005	Simpson
6,261,319	B1	7/2001	Kveen	6,904,974	B2	6/2005	Slack
6,263,966	B1	7/2001	Haut et al.	6,907,930	B2	6/2005	Cavender
6,263,972	B1	7/2001	Richard et al.	6,924,640	B2	8/2005	Fickert
6,264,685	B1	7/2001	Ahari	6,932,161	B2	8/2005	Cameron
6,273,634	B1	8/2001	Lohbeck	6,962,203	B2	11/2005	Funchess
				6,983,796	B2	1/2006	Bayne
				6,994,167	B2	2/2006	Ramos
				7,036,600	B2	5/2006	Johnson
				7,048,052	B2	5/2006	Hackworth

(56)

References Cited

U.S. PATENT DOCUMENTS

7,055,609 B2 6/2006 Hayes
 7,086,476 B2 8/2006 Johnson
 7,100,690 B2 9/2006 Mullen
 7,104,324 B2 9/2006 Wetzel
 7,108,062 B2 9/2006 Castano-Mears et al.
 7,131,494 B2 11/2006 Bixenman
 7,134,501 B2 11/2006 Johnson
 7,140,446 B2 11/2006 Metcalfe
 7,156,180 B2 1/2007 Schetky
 7,168,485 B2 1/2007 Johnson
 7,168,486 B2 1/2007 Hackworth
 7,182,134 B2 2/2007 Wetzel
 7,185,709 B2 * 3/2007 Schetky et al. 166/380
 7,191,842 B2 3/2007 Hackworth
 7,222,676 B2 5/2007 Patel
 7,235,097 B2 6/2007 Calisse
 7,291,166 B2 11/2007 Cheng
 7,300,458 B2 11/2007 Henkes
 7,398,831 B2 7/2008 Schetky
 7,476,245 B2 1/2009 Abbate
 7,681,640 B2 3/2010 Bixenman
 7,758,628 B2 7/2010 Besselink
 2001/0027339 A1 10/2001 Boatman
 2001/0044652 A1 11/2001 Moore
 2002/0035394 A1 * 3/2002 Fierens et al. 623/1.13
 2002/0092649 A1 * 7/2002 Bixenman et al. 166/278
 2002/0107562 A1 8/2002 Hart
 2002/0125009 A1 9/2002 Wetzel
 2003/0074052 A1 4/2003 Besselink
 2003/0079885 A1 5/2003 Schetky
 2003/0079886 A1 5/2003 Schetky
 2003/0199969 A1 10/2003 Steinke
 2004/0034402 A1 2/2004 Bales
 2004/0065445 A1 4/2004 Abercrombie Simpson
 2004/0088043 A1 5/2004 Klein
 2004/0089454 A1 5/2004 Hackworth
 2004/0133270 A1 7/2004 Grandt
 2004/0182581 A1 9/2004 Schetky
 2004/0193247 A1 9/2004 Besselink
 2005/0039927 A1 2/2005 Wetzel
 2005/0055080 A1 3/2005 Istephanous
 2005/0163821 A1 7/2005 Sung
 2005/0182479 A1 8/2005 Bonsignore
 2006/0037745 A1 2/2006 Hart et al.
 2006/0217795 A1 9/2006 Besselink
 2006/0241739 A1 10/2006 Besselink
 2007/0084608 A1 4/2007 Bixenman
 2007/0102153 A1 5/2007 Bixenman
 2008/0097571 A1 4/2008 Denison
 2009/0187243 A1 7/2009 Johnson

FOREIGN PATENT DOCUMENTS

AU 2006202182 A1 6/2006
 BE 1014914AS 6/2004
 CA 2602435 7/1998
 CA 2359450 4/2002
 CA 2359450 A1 4/2002
 CA 2513263 4/2002
 CA 2513263 A1 4/2002
 CA 2367810 7/2002
 CA 2367810 A1 7/2002
 CA 2544701 7/2002
 CA 2544701 A1 7/2002
 DE 8812719 11/1989
 DE 19728337 1/1999
 DE 10201631 11/2002
 DE 10201631 A1 11/2002
 EP 0274846 A1 7/1988
 EP 0326426 8/1989
 EP 0326462 A2 8/1989
 EP 0335341 A1 10/1989
 EP 0364787 4/1990
 EP 0421729 4/1991

EP 0540290 A2 5/1993
 EP 0587197 3/1994
 EP 0636345 2/1995
 EP 0664107 7/1995
 EP 0674095 9/1995
 EP 0679372 11/1995
 EP 0688545 12/1995
 EP 0734698 10/1996
 EP 0744164 11/1996
 EP 0779409 A1 6/1997
 EP 0897698 2/1999
 EP 1031329 A2 8/2000
 EP 1042997 10/2000
 EP 1152120 A2 11/2001
 EP 1223305 7/2002
 EP 1223305 A3 11/2002
 EP 1255022 A1 11/2002
 FR 2617721 A1 1/1989
 FR 2642812 8/1990
 GB 2081173 2/1982
 GB 2169515 7/1986
 GB 2175824 A 12/1986
 GB 2287093 A 9/1995
 GB 2317630 4/1998
 GB 2347448 9/2000
 GB 2355740 5/2001
 GB 2362462 A 11/2001
 GB 2366817 3/2002
 GB 2368082 4/2002
 GB 2369382 A 4/2002
 GB 2369382 5/2002
 GB 2370301 6/2002
 GB 2370574 7/2002
 GB 2371063 A 7/2002
 GB 2371064 7/2002
 GB 2371066 7/2002
 GB 2371574 7/2002
 GB 2379690 3/2003
 GB 2379691 3/2003
 GB 2379692 3/2003
 GB 2379693 3/2003
 GB 2379694 3/2003
 GB 2379694 A 3/2003
 GB 2382831 6/2003
 GB 2382831 A 6/2003
 GB 2386625 9/2003
 GB 2386625 A 9/2003
 GB 2392461 3/2004
 GB 2392461 A 3/2004
 GB 2395214 5/2004
 GB 2395214 A 5/2004
 GB 2403491 1/2005
 GB 2404683 2/2005
 GB 2404683 A 2/2005
 GB 2408531 6/2005
 GB 2408531 A 6/2005
 GB 2409694 7/2005
 GB 2409694 A 7/2005
 GB 2410273 7/2005
 GB 2410273 A 7/2005
 JP A9312743 12/1997
 JP 2002121654 4/2002
 JP 3958602 11/2002
 JP 2002332791 11/2002
 NL 1019192 4/2002
 NL 1019753 7/2002
 NL 1021076 7/2002
 NL 1022037 2/2003
 NO 20020223 A 7/2002
 NO 20034598 A 4/2004
 RU 2225497 7/2003
 RU 2225497 C2 7/2003
 RU 2263198 5/2005
 SG 104956 7/2004
 SU 1105620 7/1984
 WO 8602124 4/1986
 WO 9206734 A1 4/1992
 WO 9219310 A1 11/1992
 WO 9322986 11/1993

(56)

References Cited

FOREIGN PATENT DOCUMENTS

WO	9403127	A1	2/1994
WO	9509584		4/1995
WO	9531945		11/1995
WO	9532757		12/1995
WO	9603942		2/1996
WO	9609013		3/1996
WO	9618359		6/1996
WO	9629028		9/1996
WO	9637680		11/1996
WO	9641589		12/1996
WO	9704721		2/1997
WO	9800626		1/1998
WO	9820810		5/1998
WO	9820810	A1	5/1998
WO	9822690		5/1998
WO	9826152		6/1998
WO	WO 98/32412		7/1998
WO	9849423		11/1998
WO	9849423	A	11/1998
WO	9850673		11/1998
WO	9850680		11/1998
WO	9857030		12/1998
WO	9902818		1/1999
WO	9915108	A2	4/1999
WO	9923354		5/1999
WO	9945235		9/1999
WO	0036386	A1	6/2000
WO	0061908		10/2000
WO	0129368		4/2001
WO	0129368	A1	4/2001
WO	0142620		6/2001
WO	0142620	A1	6/2001
WO	0146551		6/2001
WO	0165063		9/2001
WO	0165067		9/2001
WO	0173264		10/2001
WO	0188332	A1	11/2001
WO	0192680		12/2001
WO	0206593		1/2002
WO	0206625		1/2002
WO	WO 02/25057		3/2002
WO	308384		2/2004
WO	2004014255		2/2004
WO	2004014255	A1	2/2004
WO	2007076051		7/2007
WO	2007076051	A3	7/2007
WO	2007126729		11/2007
WO	2007126729	A3	11/2007

OTHER PUBLICATIONS

Sides, Win, Hydraulic Intelligent Completions, Baker Hughes, Advanced Technology Conference, Sep. 30-Oct. 1, 1999, slides 1-28 (6446729).

STDZ and Multizone Completion Systems, Halliburton Company, 1995.

Hamid, Syed, Lester, G. Scott and Adkins, Darrel W.; A Fiber-Optic Inspection System for Prepacked Screens: Society of Petroleum Engineers Inc.: pp. 1-12. Apr. 1999.

U.S. Pre-Grant Pub 2003/0056947, Cameron, Mar. 2003. Hamid, Syed, Lester, G. Scott and Adkins, Darrell W.; A Fiber-Optic Inspection System for Prepacked Screens; Society of Petroleum Engineers Inc.; pp. 1-9, 1999.

Docket Sheet for *Memry Corporation v. Kentucky Oil Technology, N.V.*, Case No. H-04-1959 (S.D. Tex.) (Pacer Jun. 2, 2005) (6 pages).

Docket Sheet for *Memry Corporation v. Kentucky Oil Technology, N.V.*, Case No. C-04-03843, (N.D. Cal.) (Pacer Aug. 11, 2005) (142 pages).

Hackworth et al., Development and First Application of Bistable Expandable Sand Screen, Oct. 5-8, 2003, SPE 84265, whole document.

European Search Report dated Mar. 15, 2006 re EP 05 02 2622 (PARGN.002VR1EP) in 4 pages.

European Search Report dated Jul. 21, 2008 re EP 05 02 2622 (PARGN.002VR1EP) in 4 pages.

Communication from United States District Court Transferring Case, *Memry Corporation v. Kentucky Oil Technology, N.V.*, Case No. H-04-1959 (S.D. Tex.), dated Sep. 7, 2004 (1 page).

Schlumberger Technology Corporation's Notice of Motion and Motion to Dismiss Kentucky Oil Technology's Third, Fourth, Fifth, and Sixth Counterclaims; and Memorandum of Points and Authorities, *Memry Corporation v. Kentucky Oil Technology, N.V.*, Case No. C-04-03843, (N.D. Cal.), filed Jan. 24, 2005 (32 pages).

[Proposed] Order Granting Schlumberger Technology Corporation's Motion to Dismiss Kentucky Oil Technology's Third, Fourth, Fifth, and Sixth Counterclaims, *Memry Corporation v. Kentucky Oil Technology, N.V.*, Case No. C-04-03843, (N.D. Cal.), filed Jan. 24, 2005 (3 pages).

Schlumberger Technology Corporation's Notice of Motion and Motion to Dismiss Kentucky Oil Technology's First Amended Third, Fourth, Fifth, and Sixth Counterclaims; and Memorandum of Points and Authorities, *Memry Corporation v. Kentucky Oil Technology, N.V.*, Case No. C-04-03843, (N.D. Cal.), filed Feb. 24, 2005 (32 pages).

[Proposed] Order Granting Schlumberger Technology Corporation's Motion to Dismiss Kentucky Oil Technology's First Amended Third, Fourth, Fifth, and Sixth Counterclaims, *Memry Corporation v. Kentucky Oil Technology, N.V.*, Case No. C-04-03843, (N.D. Cal.), filed Feb. 24, 2005 (3 pages).

Plaintiff and Counterdefendant Memry Corporation's Notice of Motion and Motion to Dismiss Kentucky Oil Technology's Third, Fourth, Fifth, and Sixth Counterclaims; and Memorandum of Points and Authorities, *Memry Corporation v. Kentucky Oil Technology, N.V.*, Case No. C-04-03843, (N.D. Cal.), filed Feb. 25, 2005 (29 pages).

Request for Judicial Notice in Support of Memry Corporation's Motion to Dismiss Kentucky Oil Technology's Third, Fourth, Fifth, and Sixth Counterclaims, *Memry Corporation v. Kentucky Oil Technology, N.V.*, Case No. C-04-03843, (N.D. Cal.), filed Feb. 25, 2005 (3 pages).

[Proposed] Order Granting Memry Corporation's Motion to Dismiss Kentucky Oil Technology's Third, Fourth, Fifth, and Sixth Counterclaims, *Memry Corporation v. Kentucky Oil Technology, N.V.*, Case No. C-04-03843, (N.D. Cal.), filed Feb. 25, 2005 (3 pages).

Opposition of Kentucky Oil to Motions of Memry Corporation and Schlumberger Technology Corporation to Dismiss First Amended Counterclaims, *Memry Corporation v. Kentucky Oil Technology, N.V.*, Case No. C-04-03843, (N.D. Cal.), filed Mar. 11, 2005 (29 pages).

Kentucky Oil's Opposition to Counterdefendants' Requests for Judicial Notice in Support of Their Motions to Dismiss Kentucky Oil Technology's First Amended Third, Fourth, Fifth, and Sixth Counterclaims, *Memry Corporation v. Kentucky Oil Technology, N.V.*, Case No. C-04-03843, (N.D. Cal.), filed Mar. 11, 2005 (3 pages).

Plaintiff and Counterdefendant Memry Corporation's Reply in Support of Motion to Dismiss Kentucky Oil Technology's Third, Fourth, Fifth, and Sixth Counterclaims, *Memry Corporation v. Kentucky Oil Technology, N.V.*, Case No. C-04-03843, (N.D. Cal.), filed Mar. 18, 2005 (9 pages).

Reply of Schlumberger Technology Corporation to Kentucky Oil Technology's Opposition to First Amended, Third, Fourth, Fifth, and Sixth Counterclaims, *Memry Corporation v. Kentucky Oil Technology, N.V.*, Case No. C-04-03843, (N.D. Cal.), filed Mar. 18, 2005 (17 pages).

Schlumberger's Response to Kentucky Oil's Opposition to Counterdefendants' Requests for Judicial Notice, *Memry Corporation v. Kentucky Oil Technology, N.V.*, Case No. C-04-03843, (N.D. Cal.), filed Mar. 18, 2005 (3 pages).

Schlumberger's Notice of Motion and Motion to Strike Exhibits 1, 2, and 4 to the Declaration of Nicola A. Pisano, *Memry Corporation v. Kentucky Oil Technology, N.V.*, Case No. C-04-03843, (N.D. Cal.), filed Mar. 18, 2005 (3 pages).

Kentucky Oil's Opposition to STC's Motion to Strike Exhibits 1, 3 and 4 to the Declaration of Nicola A. Pisano, *Memry Corporation v. Kentucky Oil Technology, N.V.*, Case No. C-04-03843, (N.D. Cal.), filed Mar. 25, 2005 (3 pages).

(56)

References Cited

OTHER PUBLICATIONS

Plaintiff and Counterdefendant Memry Corporation's Reply to Kentucky Oil Technology N.V.'s Counterclaims and Demand for Jury Trial, *Memry Corporation v. Kentucky Oil Technology, N.V.*, Case No. C-04-03843, (N.D. Cal.), filed Apr. 18, 2005 (8 pages).

Second Amended Counterclaims of Kentucky Oil Technology N.V. Against Memry Corporation and Schlumberger Technology Corporation, *Memry Corporation v. Kentucky Oil Technology, N.V.*, Case No. C-04-03843, (N.D. Cal.), filed May 6, 2005 (20 pages).

Plaintiff Memry Corporation's Reply to Kentucky Oil Technology N.V.'s Second Amended Counterclaims and Demand for Jury Trial, *Memry Corporation v. Kentucky Oil Technology, N.V.*, Case No. C-04-03843, (N.D. Cal.), filed Jun. 3, 2005 (9 pages).

Schlumberger Technology Corporation's Notice of Motion and Motion to Dismiss the Fourth, Fifth, Sixth, Seventh and Eighth Counterclaims in Kentucky Oil Technology's Second Amended Counterclaims, *Memry Corporation v. Kentucky Oil Technology, N.V.*, Case No. C-04-03843, (N.D. Cal.), filed Jun. 3, 2005 (18 pages).

Opposition of Kentucky Oil Technology to Schlumberger Technology Corporation's Motion to Dismiss Kentucky Oil's Second Amended Counterclaims, *Memry Corporation v. Kentucky Oil Technology, N.V.*, Case No. C-04-03843, (N.D. Cal.), filed Jun. 17, 2005 (16 pages).

Schlumberger Technology Corporation's Reply Brief in Support of its Motion to Dismiss the Fourth, Fifth, Sixth, Seventh and Eighth Counterclaims in Kentucky Oil Technology's Second Amended Counterclaims, *Memry Corporation v. Kentucky Oil Technology, N.V.*, Case No. C-04-03843, (N.D. Cal.), filed Jun. 24, 2005 (11 pages).

Order Granting in Part and Denying In Part STC's Motion to Dismiss, *Memry Corporation v. Kentucky Oil Technology, N.V.*, Case No. C-04-03843, (N.D. Cal.), entered Jul. 14, 2005 (8 pages).

Notice of Motion and Motion by Kentucky Oil to Compel Production of Documents by Schlumberger Technology Corporation Pursuant to Fed. R. Civ. Rule 37; Memorandum of Points and Authorities in Support Thereof; Declaration of Michael Bierman, *Memry Corporation v. Kentucky Oil Technology, N.V.*, Case No. C-04-03843, (N.D. Cal.), filed Jul. 28, 2005 (32 pages).

Schlumberger Technology Corporation's Opposition to Kentucky Oil Technology's Motion to Compel, *Memry Corporation v. Kentucky Oil Technology, N.V.*, Case No. C-04-03843, (N.D. Cal.), filed Aug. 4, 2005 (21 pages).

Declaration of David B. Moyer in Support of Schlumberger Technology Corporation's Opposition to Kentucky Oil Technology's Motion to Compel, *Memry Corporation v. Kentucky Oil Technology, N.V.*, Case No. C-04-03843, (N.D. Cal.), filed Aug. 4, 2005 (51 pages).

Kentucky Oil's Reply in Support of Motion to Compel, *Memry Corporation v. Kentucky Oil Technology, N.V.*, Case No. C-04-03843, (N.D. Cal.), filed Aug. 10, 2005 (18 pages).

Order Granting Kentucky Oil's Motion to Compel Production of Documents, *Memry Corporation v. Kentucky Oil Technology, N.V.*, Case No. C-04-03843, (N.D. Cal.), entered Aug. 17, 2005 (8 pages).

[Proposed] Order Granting Kentucky Oil's Motion to Strike Declaration of Benjamin Holl and Portions of Counterdefendants' Reply Briefs, *Memry Corporation v. Kentucky Oil Technology, N.V.*, Case No. C-04-03843, (N.D. Cal.), entered Mar. 25, 2005 (2 pages).

Answer of Defendants and Counterclaims of Kentucky Oil Technology N.V. Against Memry Corporation and Schlumberger Technology Corporation, *Memry Corporation v. Kentucky Oil Technology, N.V.*, Case No. C-04-03843, (N.D. Cal.) filed Nov. 2, 2004 (20 pages).

Declaration of Nicola A. Pisano in Support of Kentucky Oil's Motion to Compel, *Memry Corporation v. Kentucky Oil Technology, N.V.*, Case No. C-04-03843, (N.D. Cal.), filed Aug. 10, 2005 (69 pages). Defendants' Motions (1) to Dismiss the Complaint for Insufficiency of Process and Lack of Personal Jurisdiction, (2) to Dismiss Counts I-III of the Complaint for Failure to State a Claim, and (3) in the Alternative, to Transfer This Action to the Federal District Court for the Northern District of California, *Memry Corporation v. Kentucky Oil Technology, N.V.*, Case No. H-04-1959, (S.D. Tex.), filed Jul. 7, 2004 (47 pages).

First Amended Counterclaims of Kentucky Oil Technology N.V. Against Memry Corporation and Schlumberger Technology Corporation, *Memry Corporation v. Kentucky Oil Technology, N.V.*, Case No. C-04-03843, (N.D. Cal.), filed Feb. 9, 2005 (16 pages).

Order Granting in Part and Denying in Part Counterdefendants' Motion to Dismiss, *Memry Corporation v. Kentucky Oil Technology, N.V.*, Case No. C-04-03843, (N.D. Cal.), entered Apr. 8, 2005 (26 pages).

Plaintiff and Counterdefendant Memry Corporation's Answer to Kentucky Oil Technology N.V.'s Counterclaims and Demand for Jury Trial, *Memry Corporation v. Kentucky Oil Technology, N.V.*, Case No. C-04-03843, (N.D. Cal.), filed Dec. 3, 2004 (10 pages).

Plaintiff and Counterdefendant Memry Corporation's Reply in Support of Request for Judicial Notice, *Memry Corporation v. Kentucky Oil Technology, N.V.*, Case No. C-04-03843, (N.D. Cal.), filed Mar. 18, 2005 (4 pages).

Plaintiffs First Amended Complaint, *Memry Corporation v. Kentucky Oil Technology, N.V.*, Case No. C-04-03843, (N.D. Cal.), filed Aug. 19, 2004 (20 pages).

Plaintiffs' Original Complaint, *Memry Corporation v. Kentucky Oil Technology, N.V.*, Case No. H-04-1959, (S.D. Tex.), filed May 14, 2004 (20 pages).

Request for Judicial Notice in Support of Schlumberger Technology Corporation's Motion to Dismiss Kentucky Oil Technology's First Amended Third, Fourth, Fifth, and Sixth Counterclaims, *Memry Corporation v. Kentucky Oil Technology, N.V.*, Case No. C-04-03843, (N.D. Cal.), filed Feb. 24, 2005 (3 pages).

Kentucky Oil's Notice of Motion and Motion to Strike Declaration of Benjamin Holl and Portions of Counterdefendants' Reply Briefs, *Memry Corporation v. Kentucky Oil Technology, N.V.*, Case No. C-04-03843, (N.D. Cal.), filed Mar. 25, 2005 (4 pages).

Schlumberger Technology Corporation's Answer to Kentucky Oil Technology's Second Amended Counterclaims, *Memry Corporation v. Kentucky Oil Technology, N.V.*, Case No. C-04-03843, (N.D. Cal.), filed Jul. 28, 2005 (8 pages).

Besselink, Peter, Biflex Stents; SMST-99; Proceedings of the First European Conference on Shape Memory and Superelastic Technologies, Antwerp Zoo, Belgium, 1999; pp. 142-150.

Office Action for U.S. Appl. No. 12/872,178 dated Jul. 28, 2011.

Office Action for U.S. Appl. No. 12/872,154 dated Feb. 25, 2011.

Office Action for U.S. Appl. No. 12/872,178 dated Mar. 1, 2011.

Office Action for U.S. Appl. No. 12/872,220 dated Mar. 3, 2011.

Office Action for U.S. Appl. No. 12/872,220 dated Jul. 19, 2011.

Office Action for U.S. Appl. No. 12/872,154 dated Jul. 20, 2011.

* cited by examiner

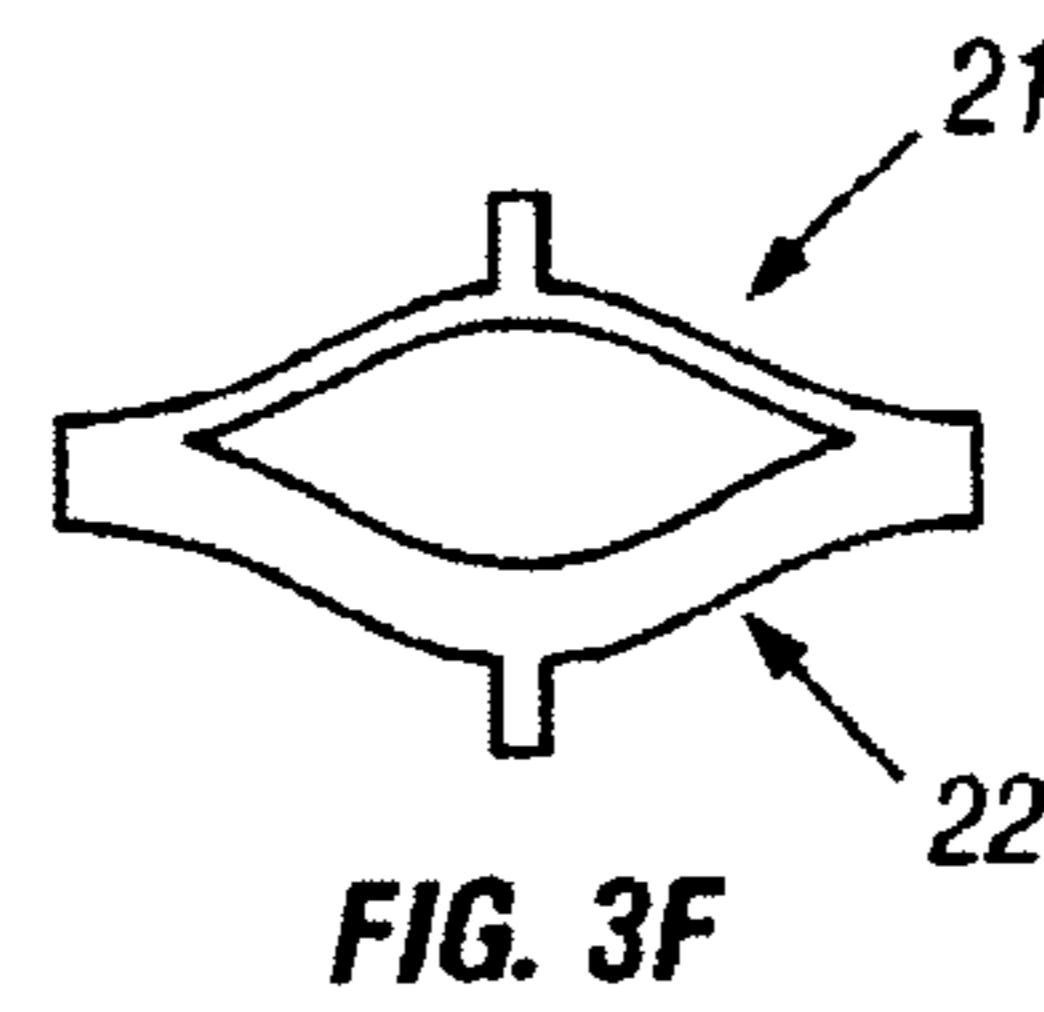
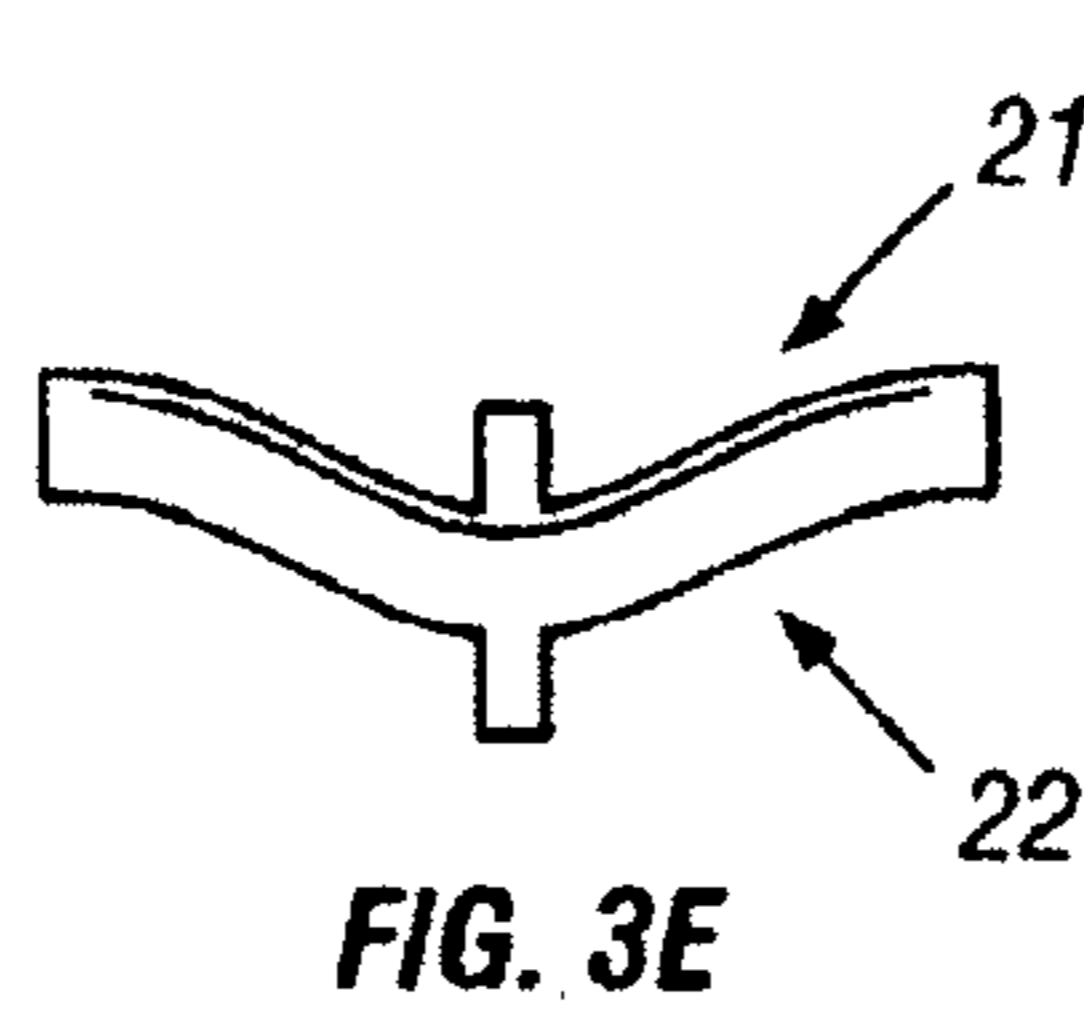
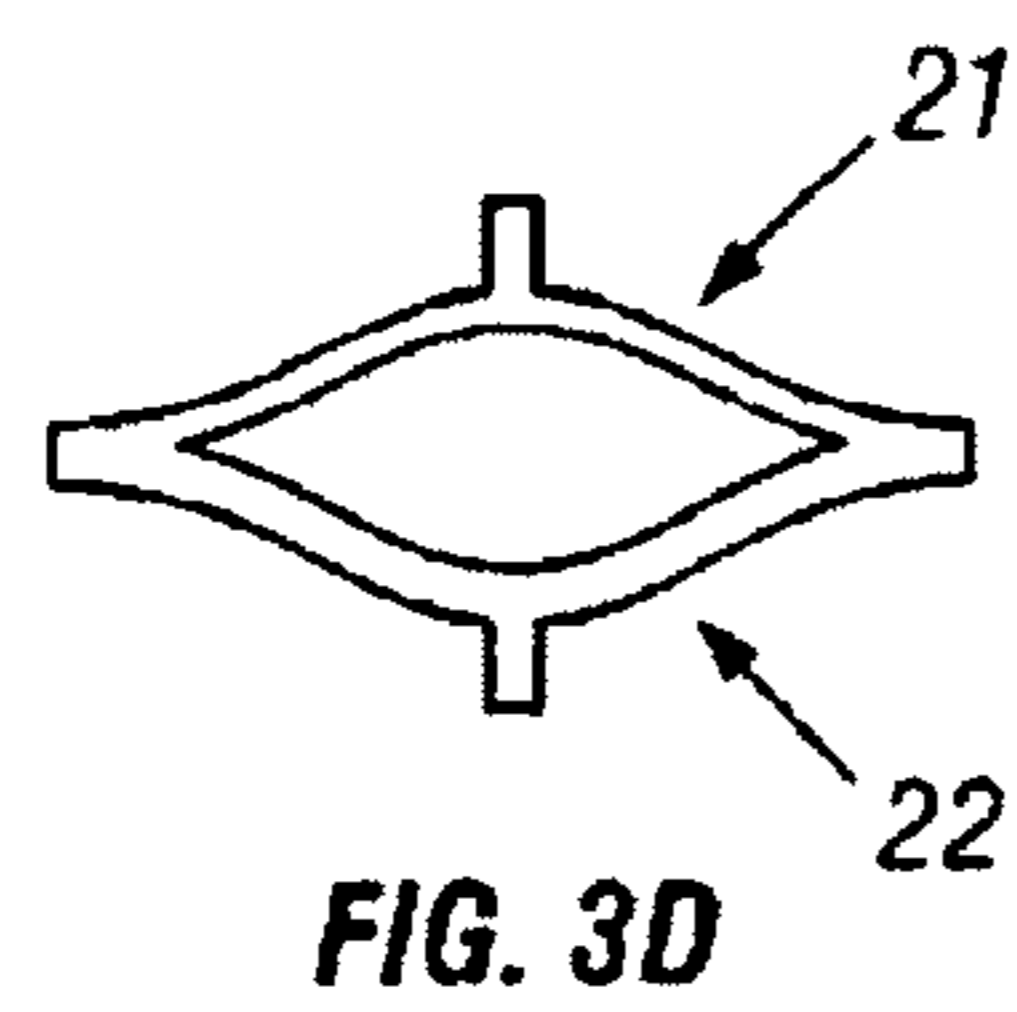
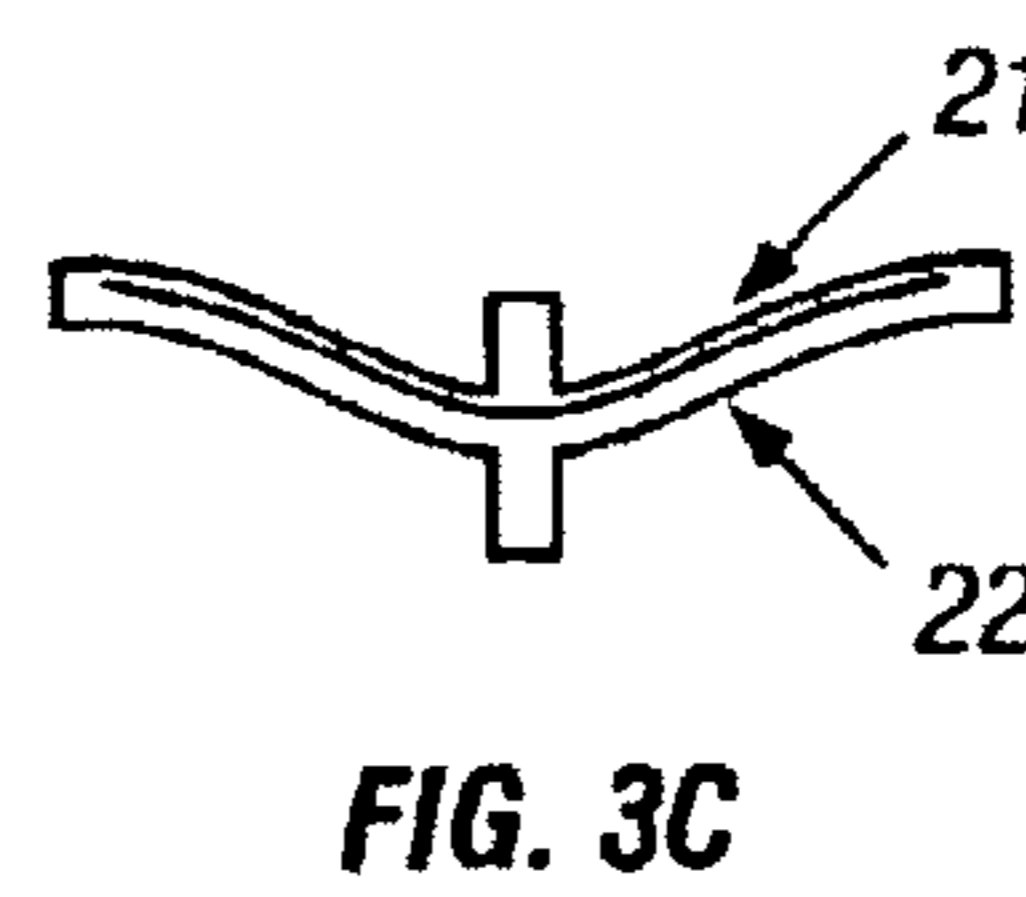
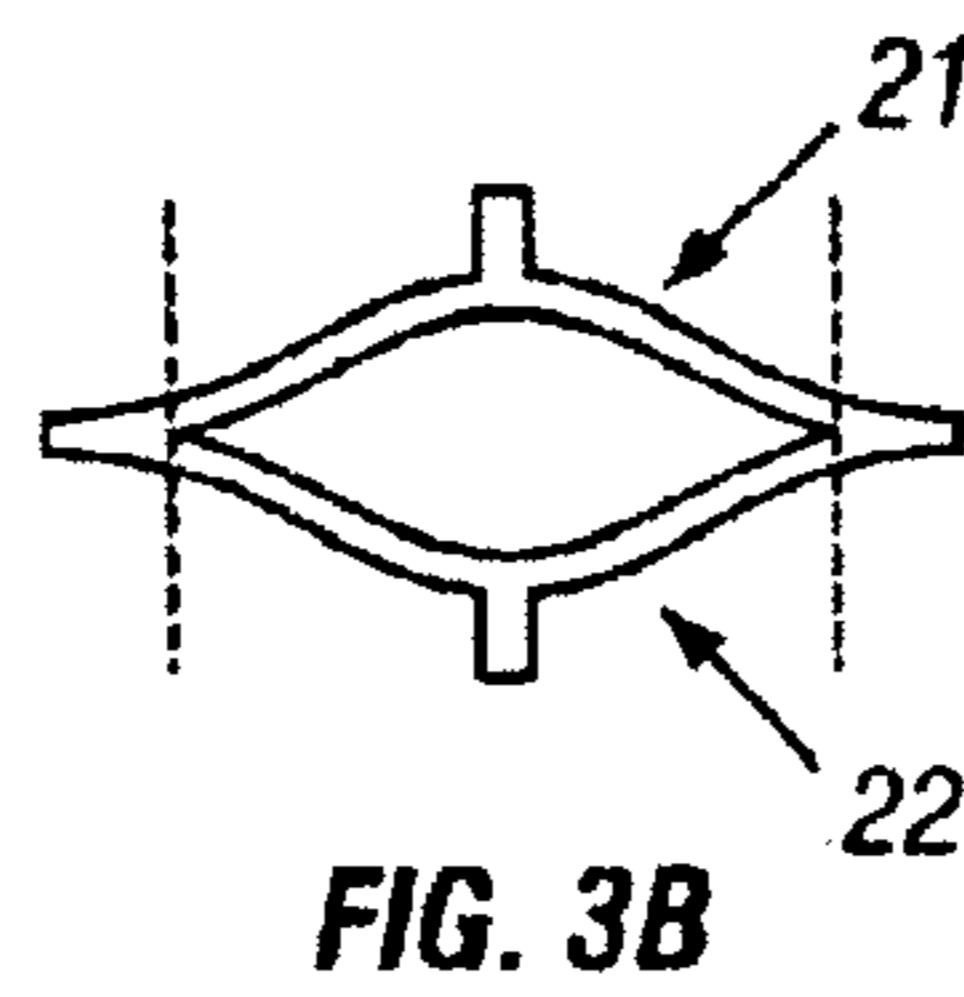
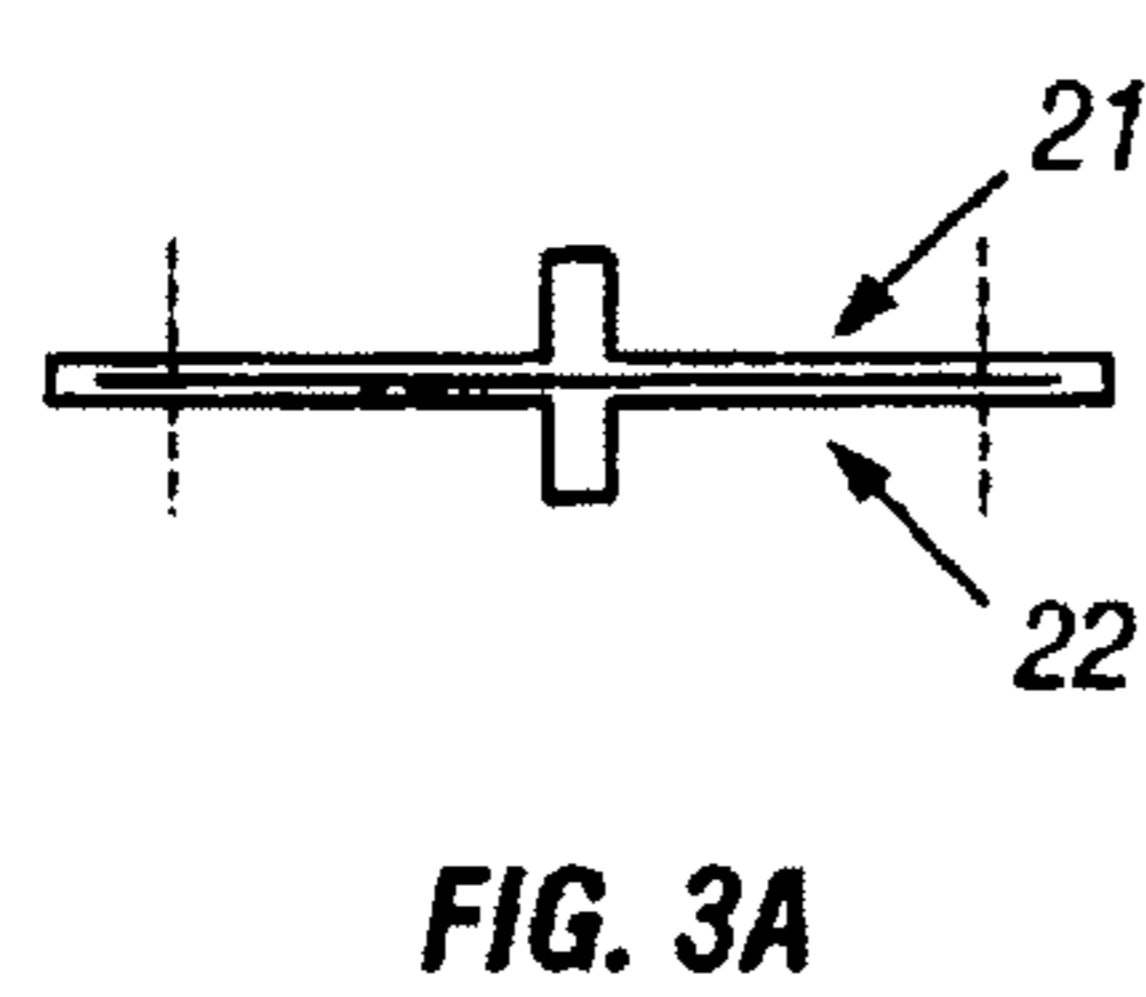
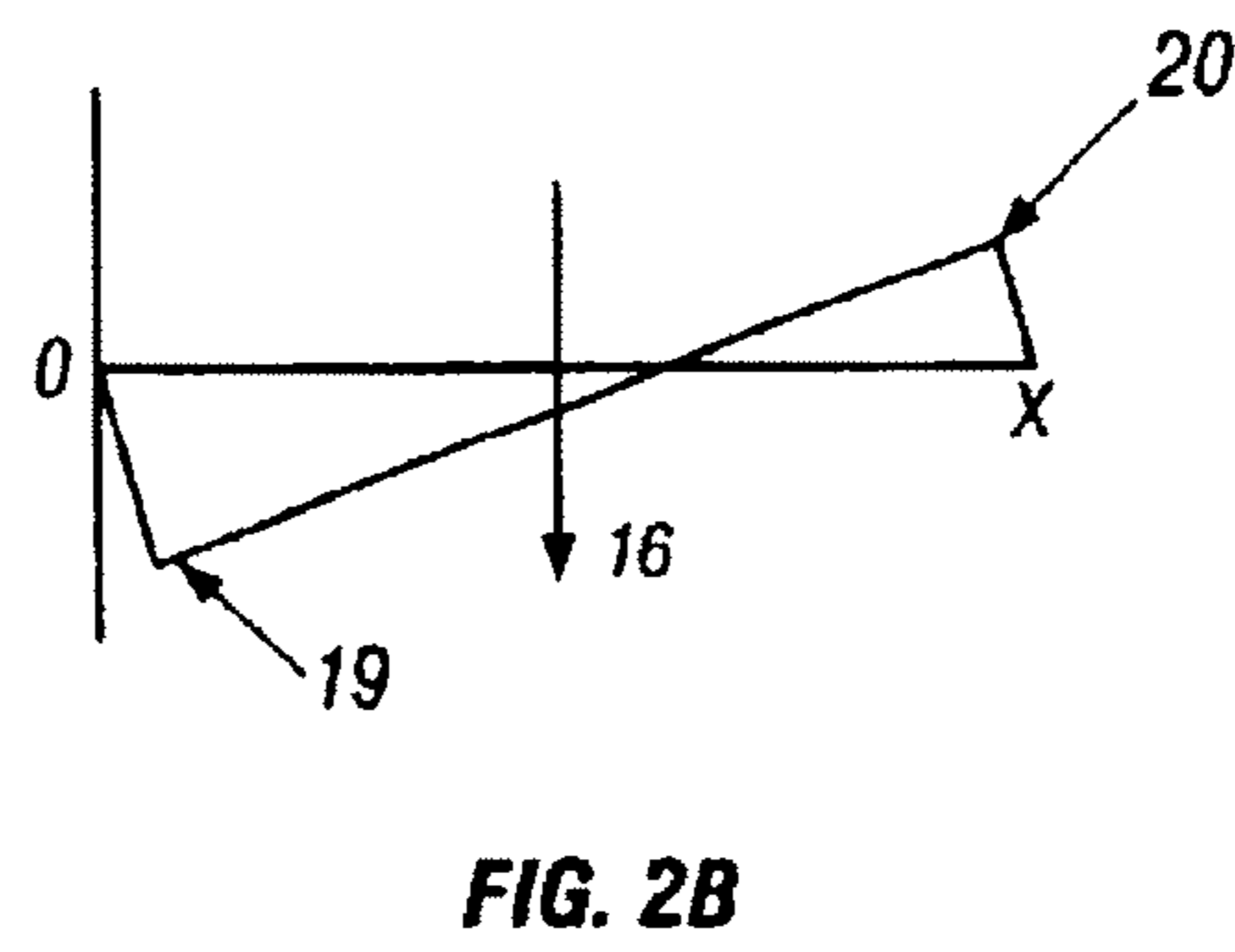
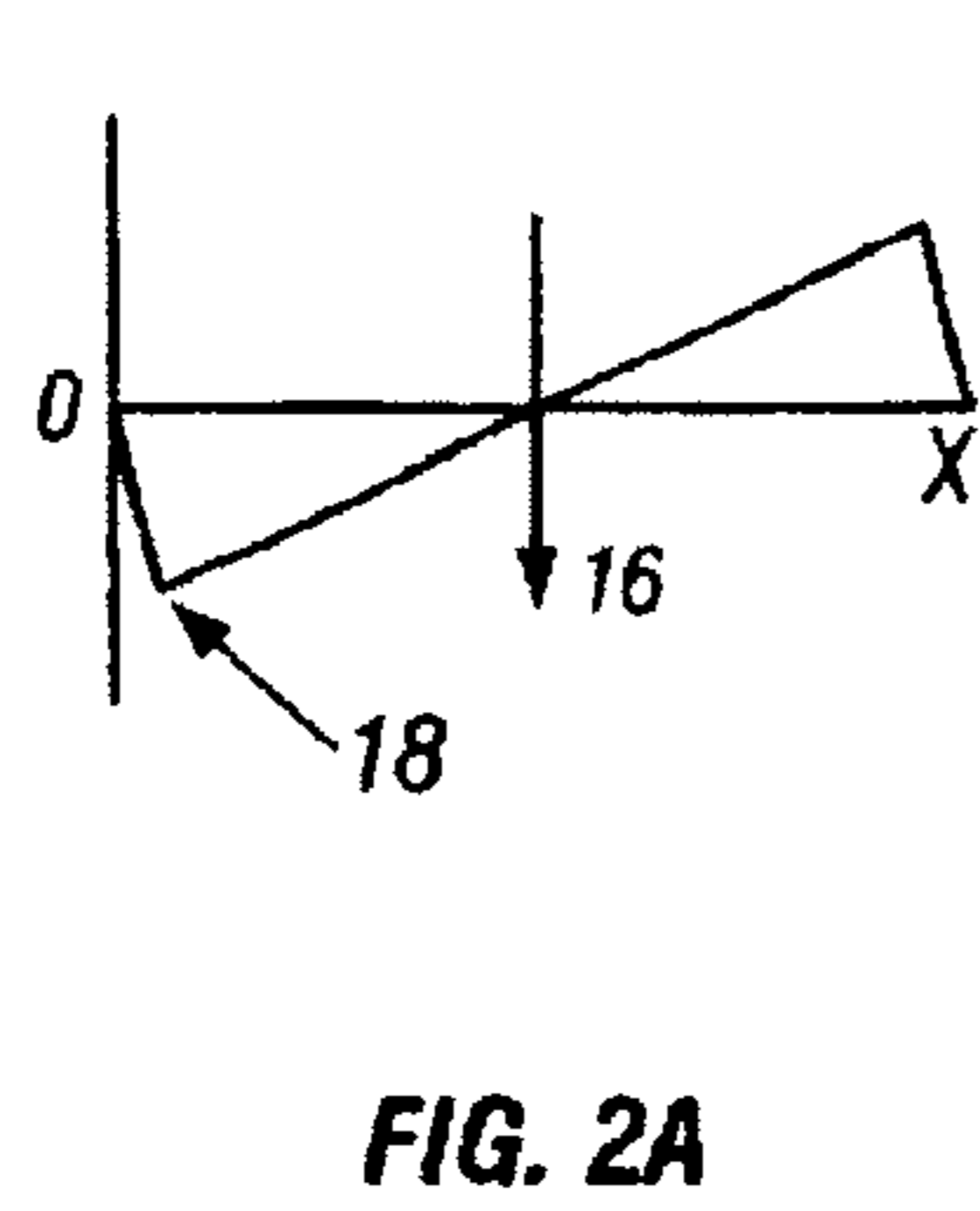
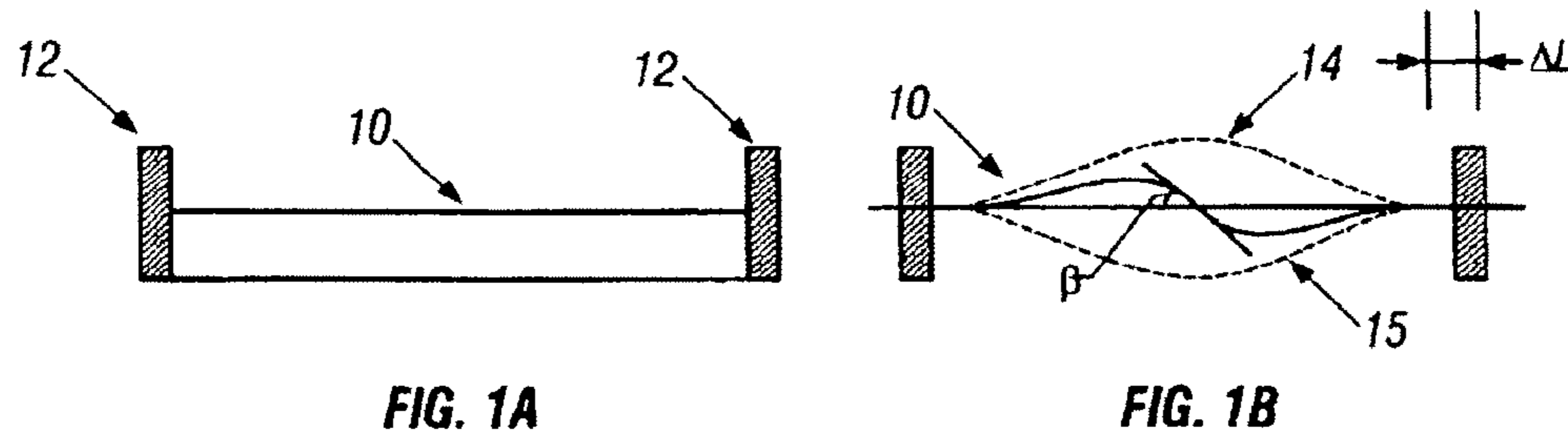

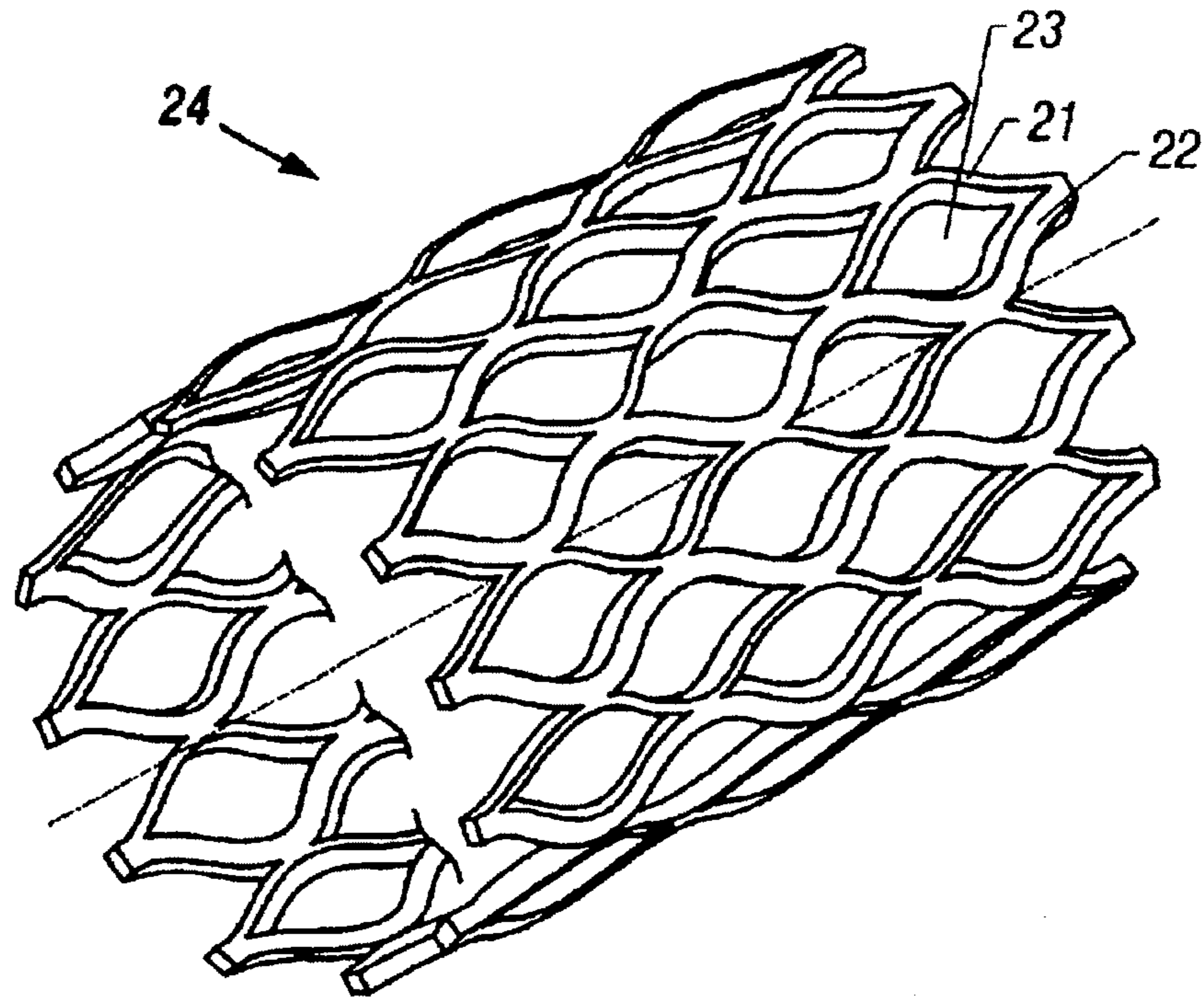

FIG. 4A

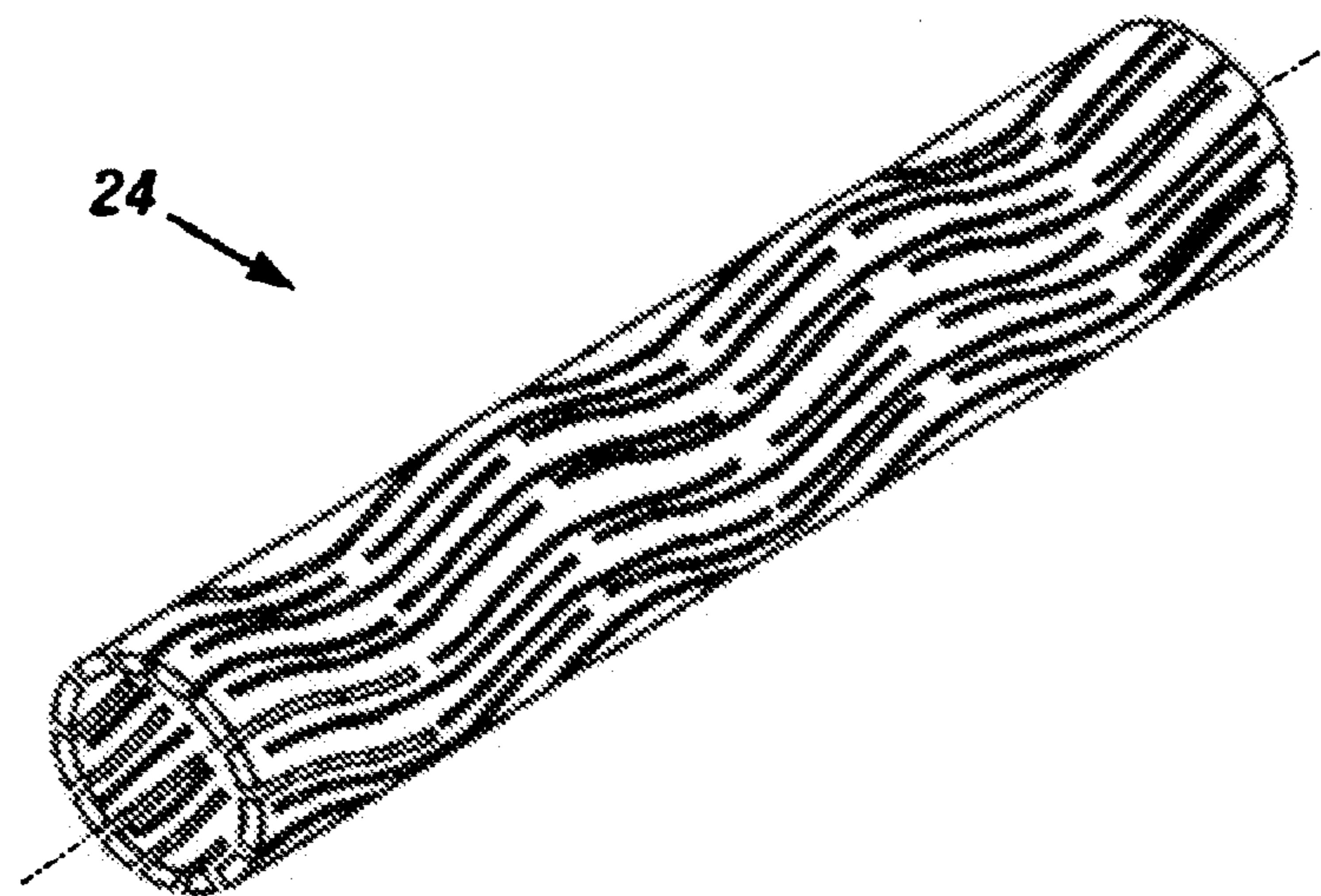

FIG. 4B

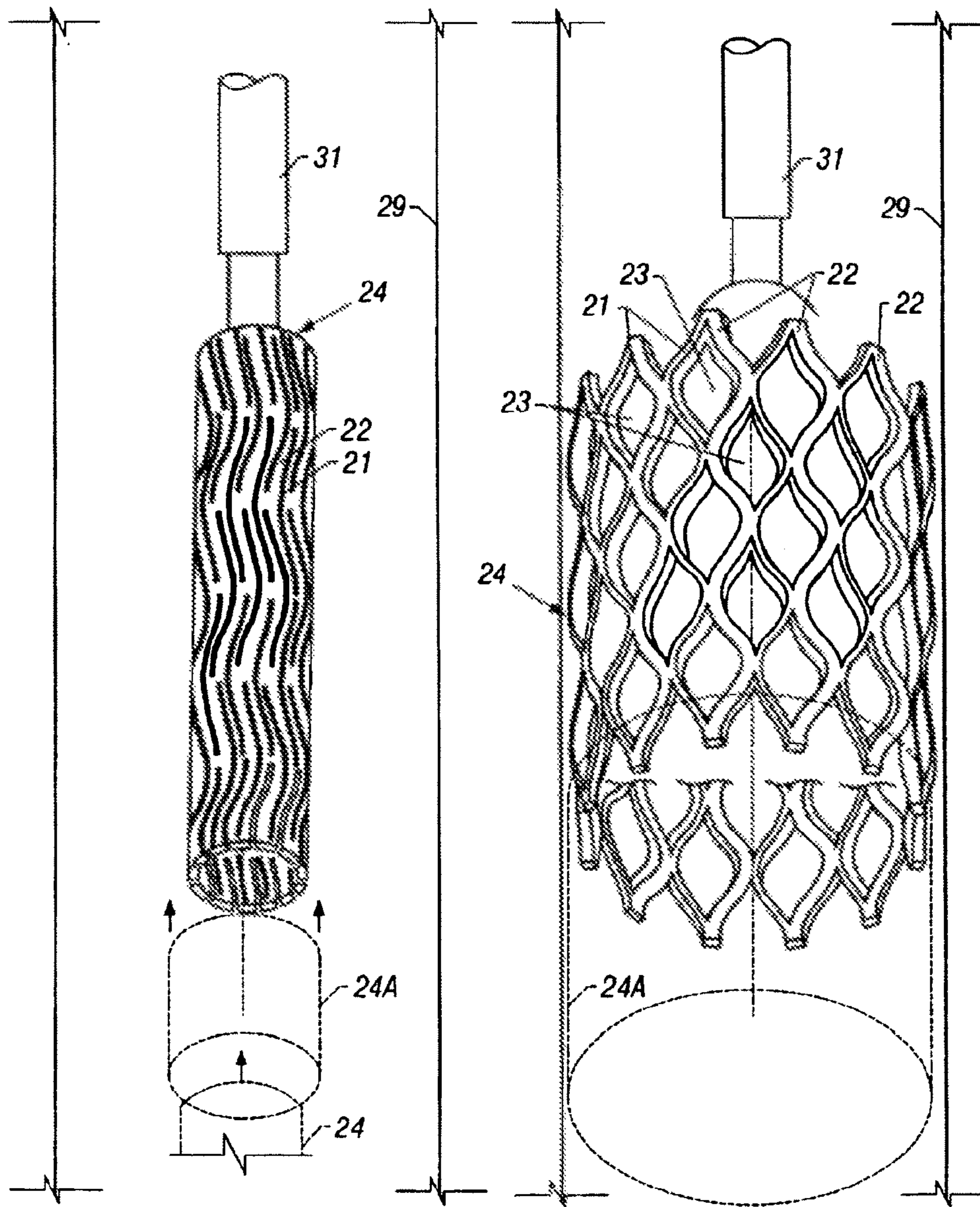

FIG. 4C

FIG. 4D

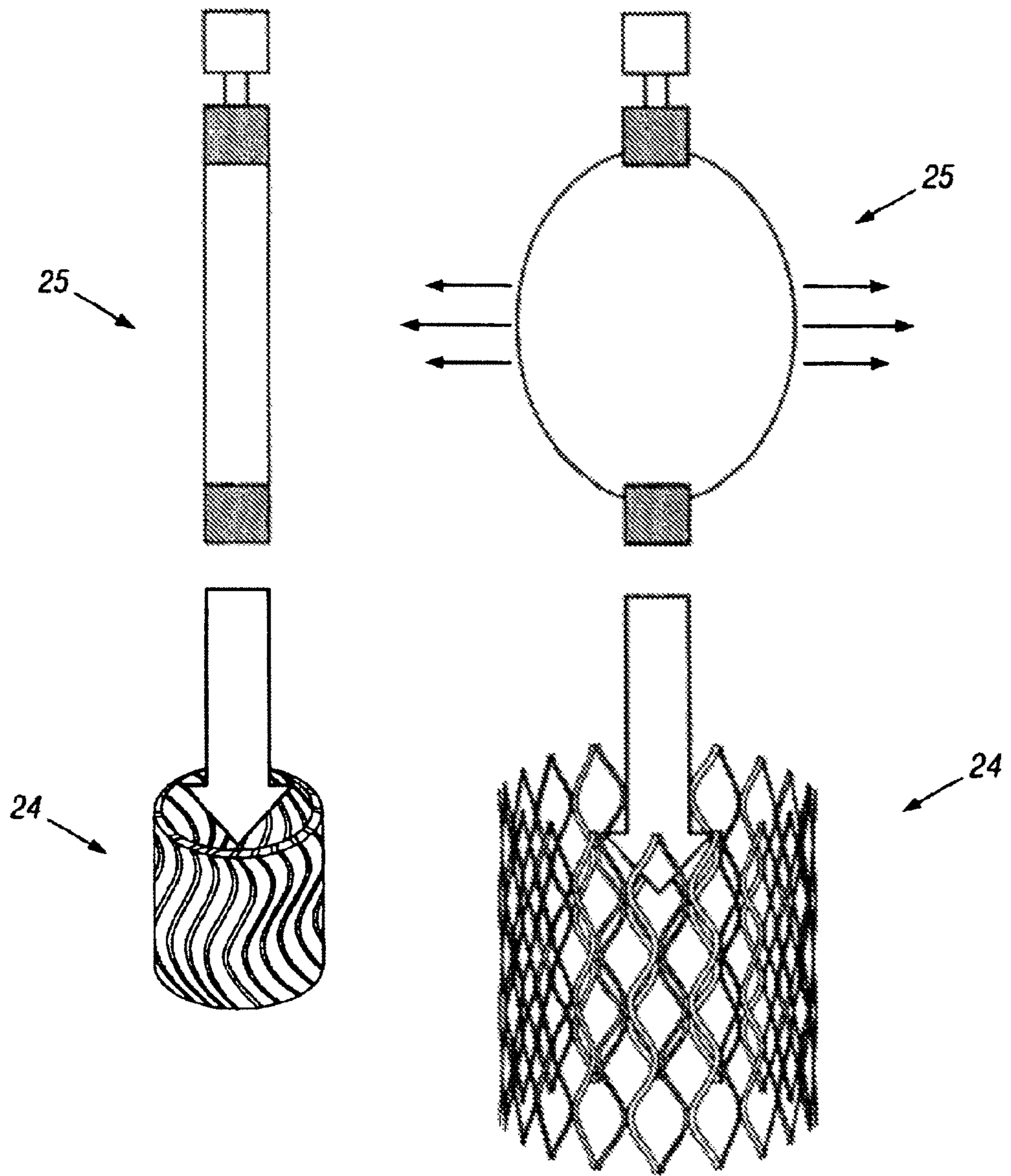

FIG. 5A

FIG. 5B

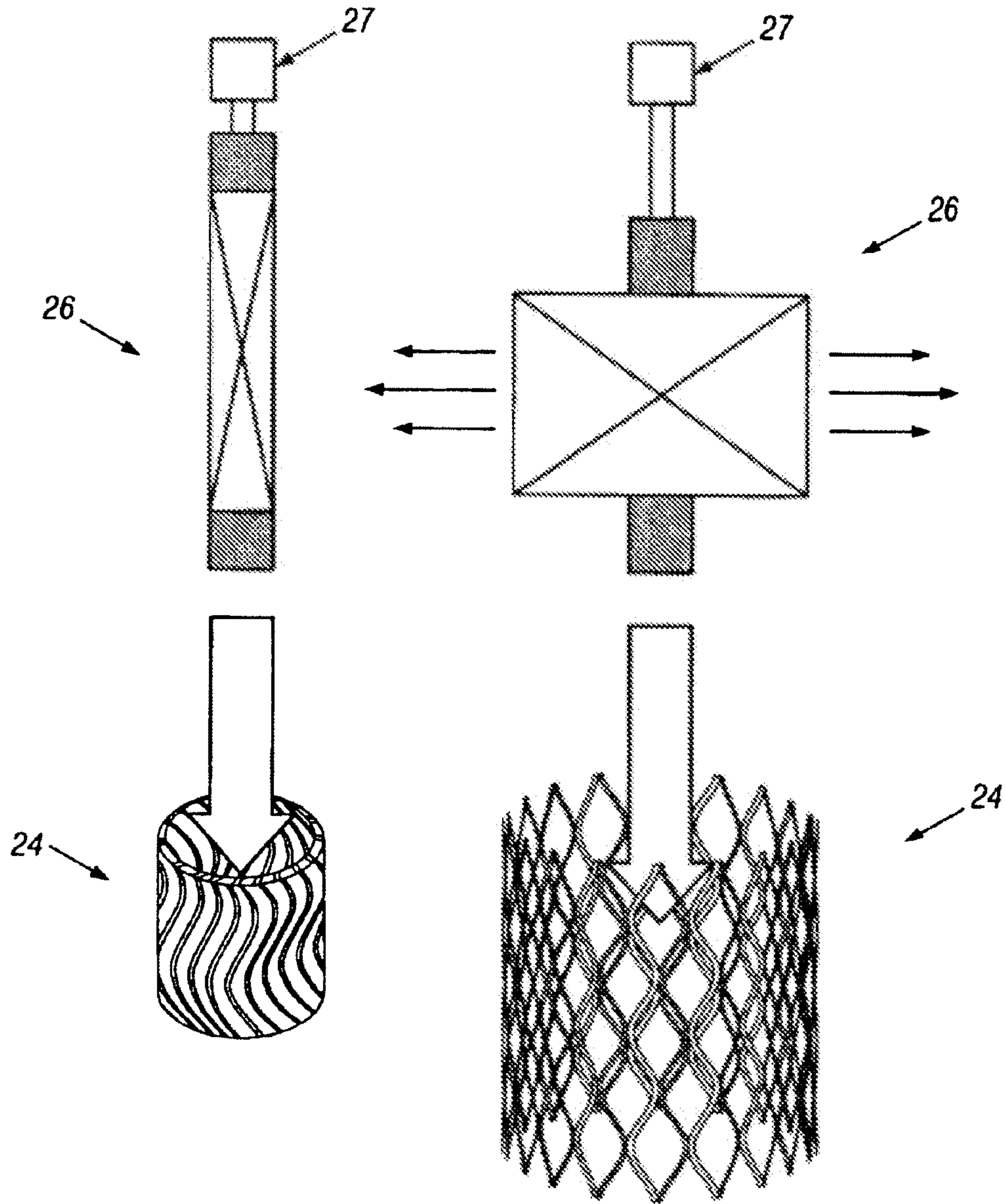

FIG. 6A

FIG. 6B

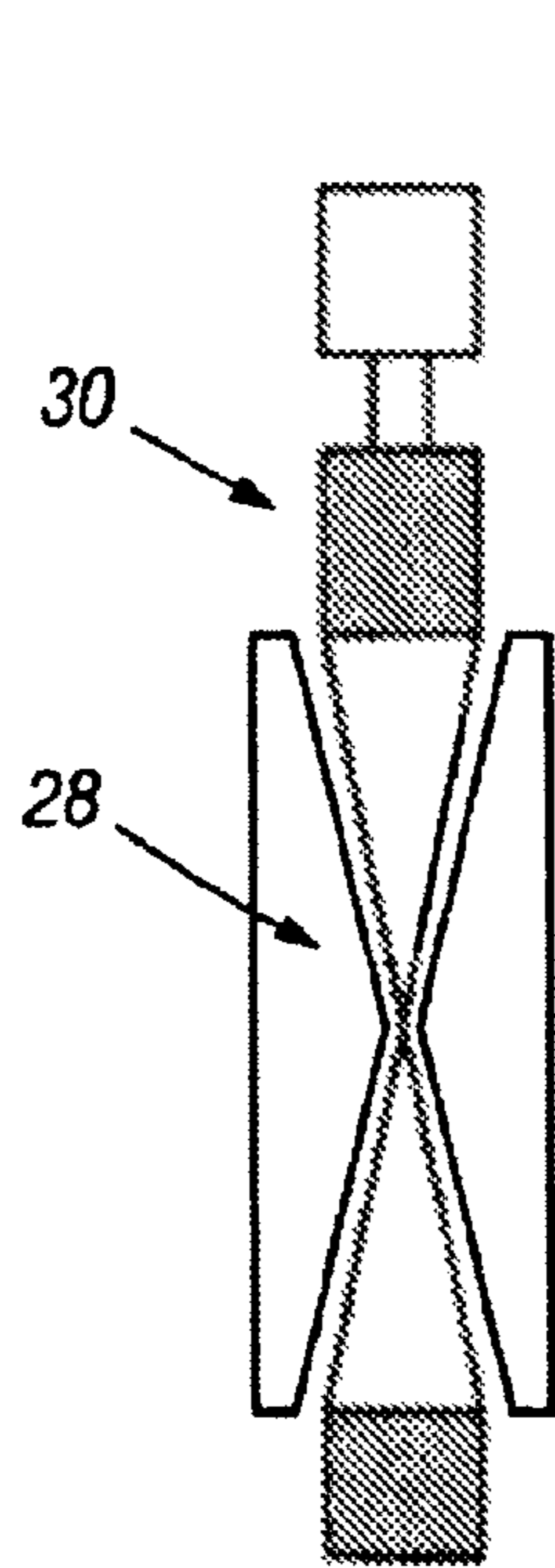

FIG. 7A

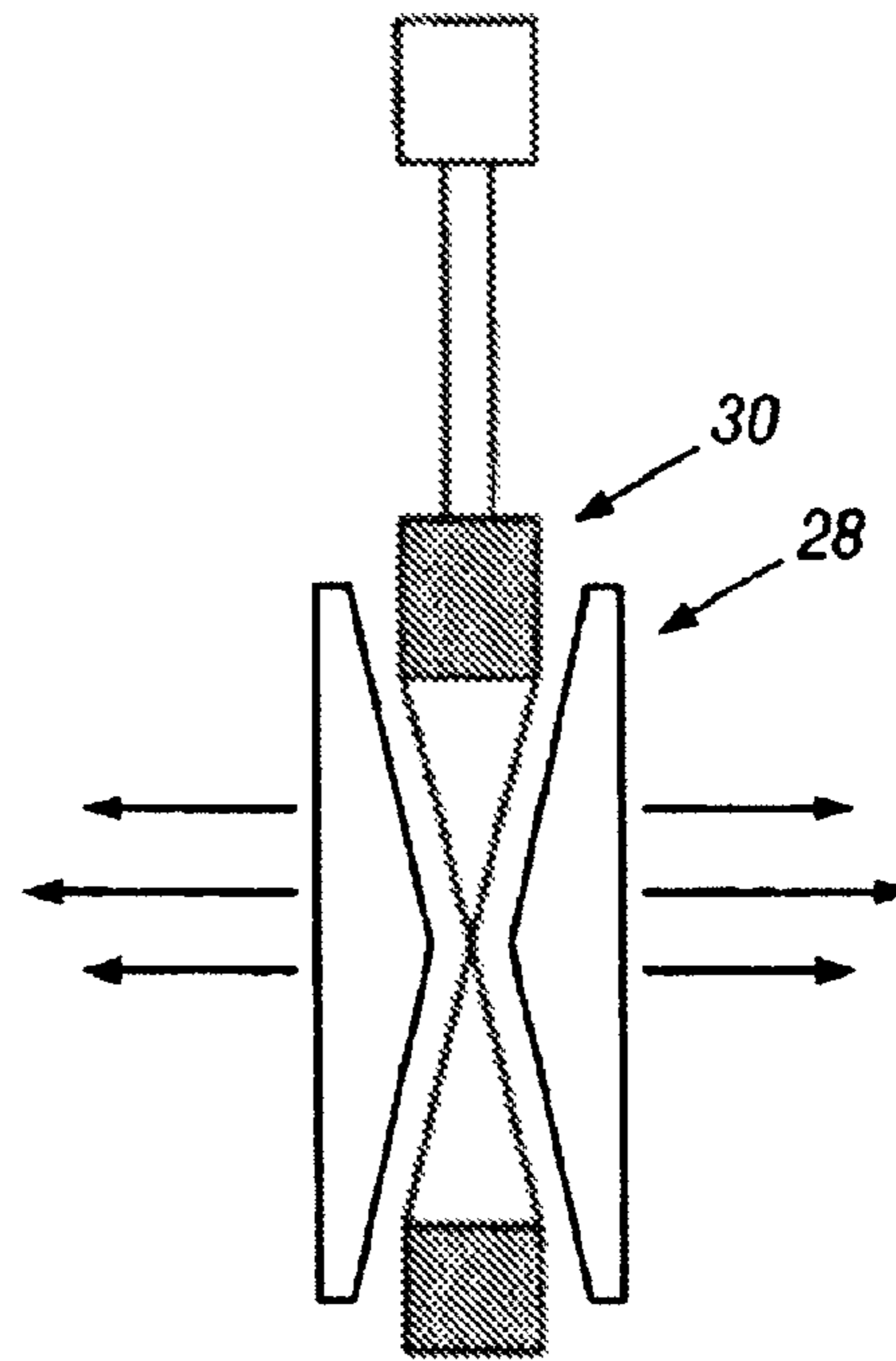

FIG. 7B

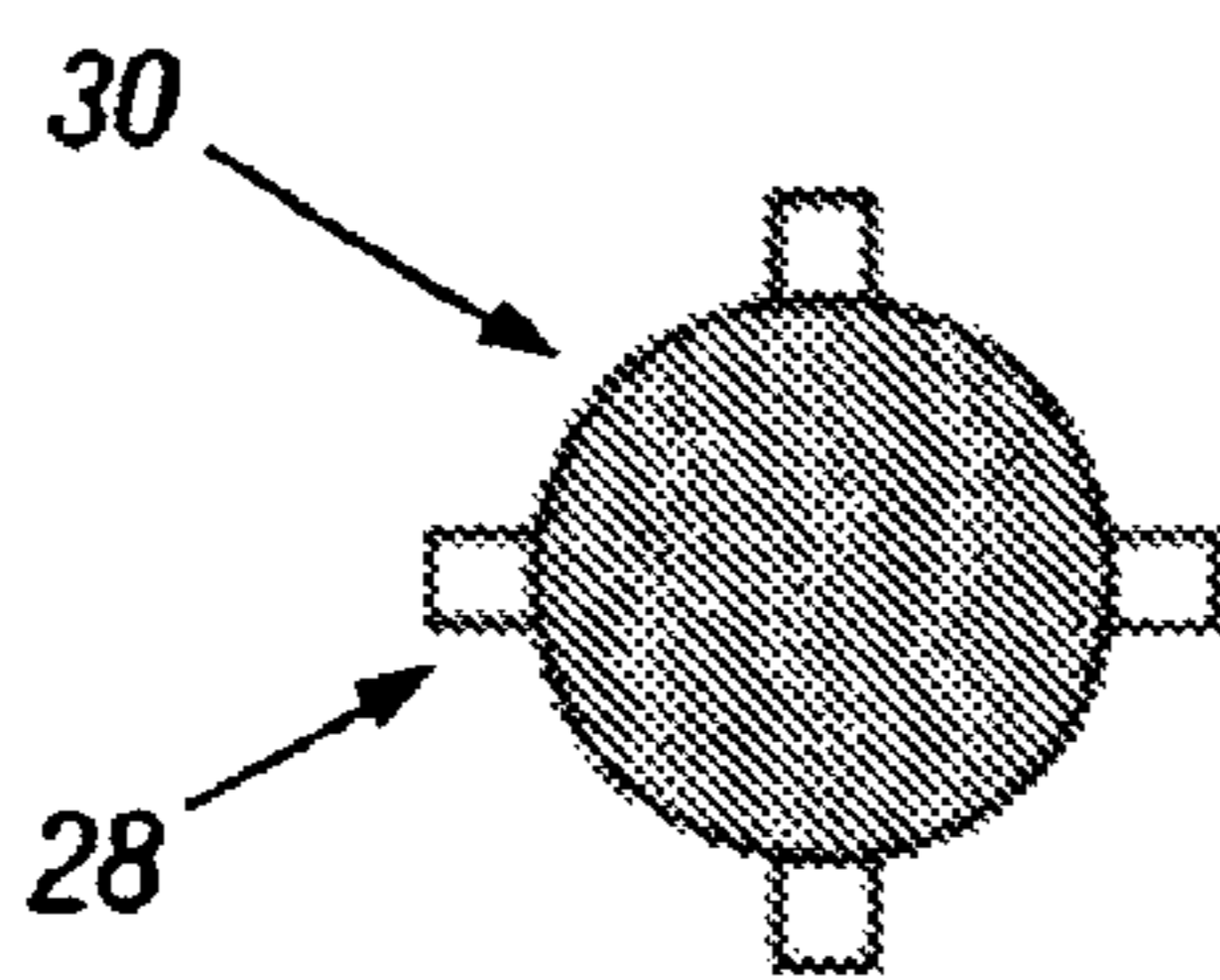

FIG. 7C

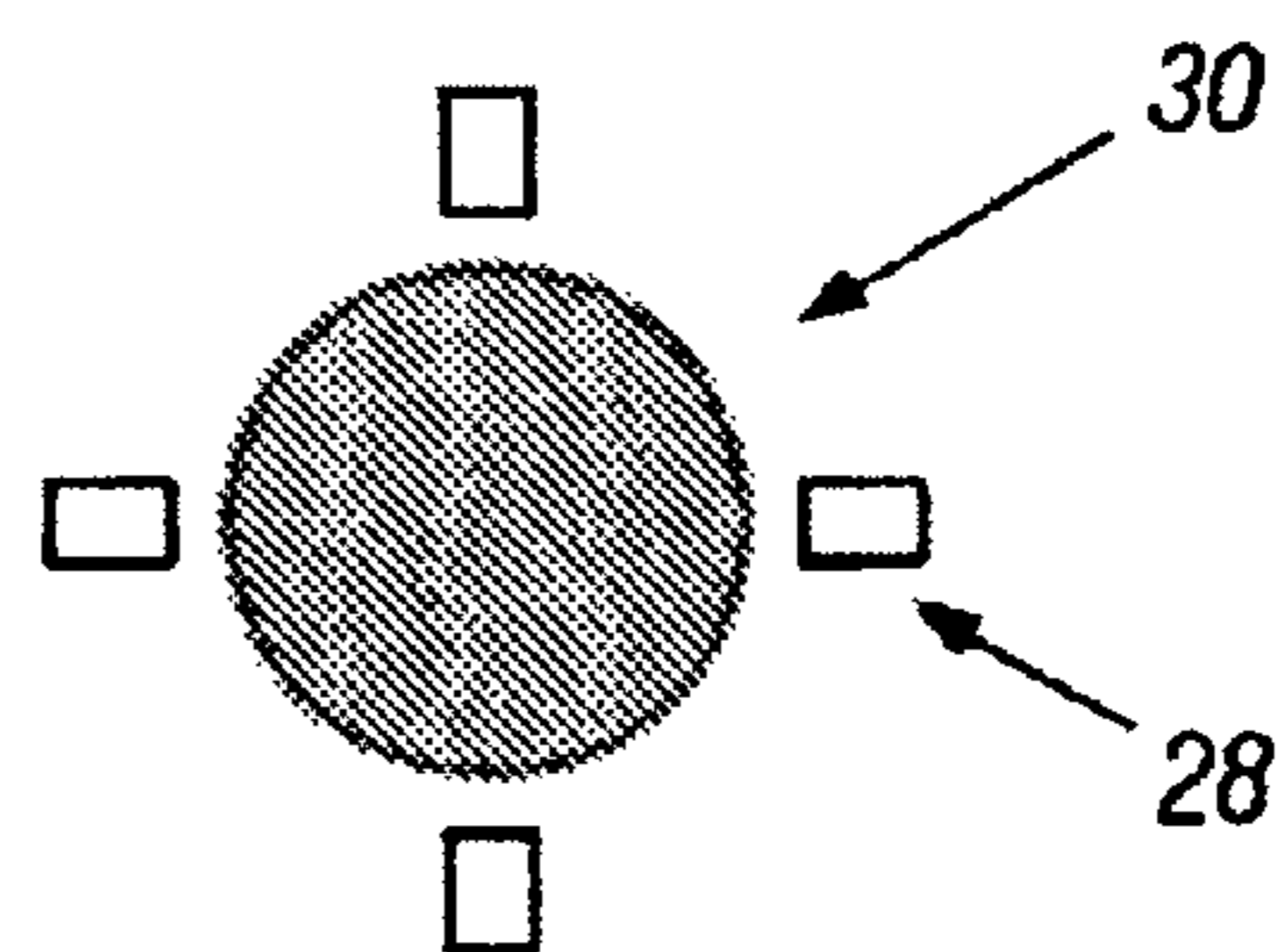

FIG. 7D

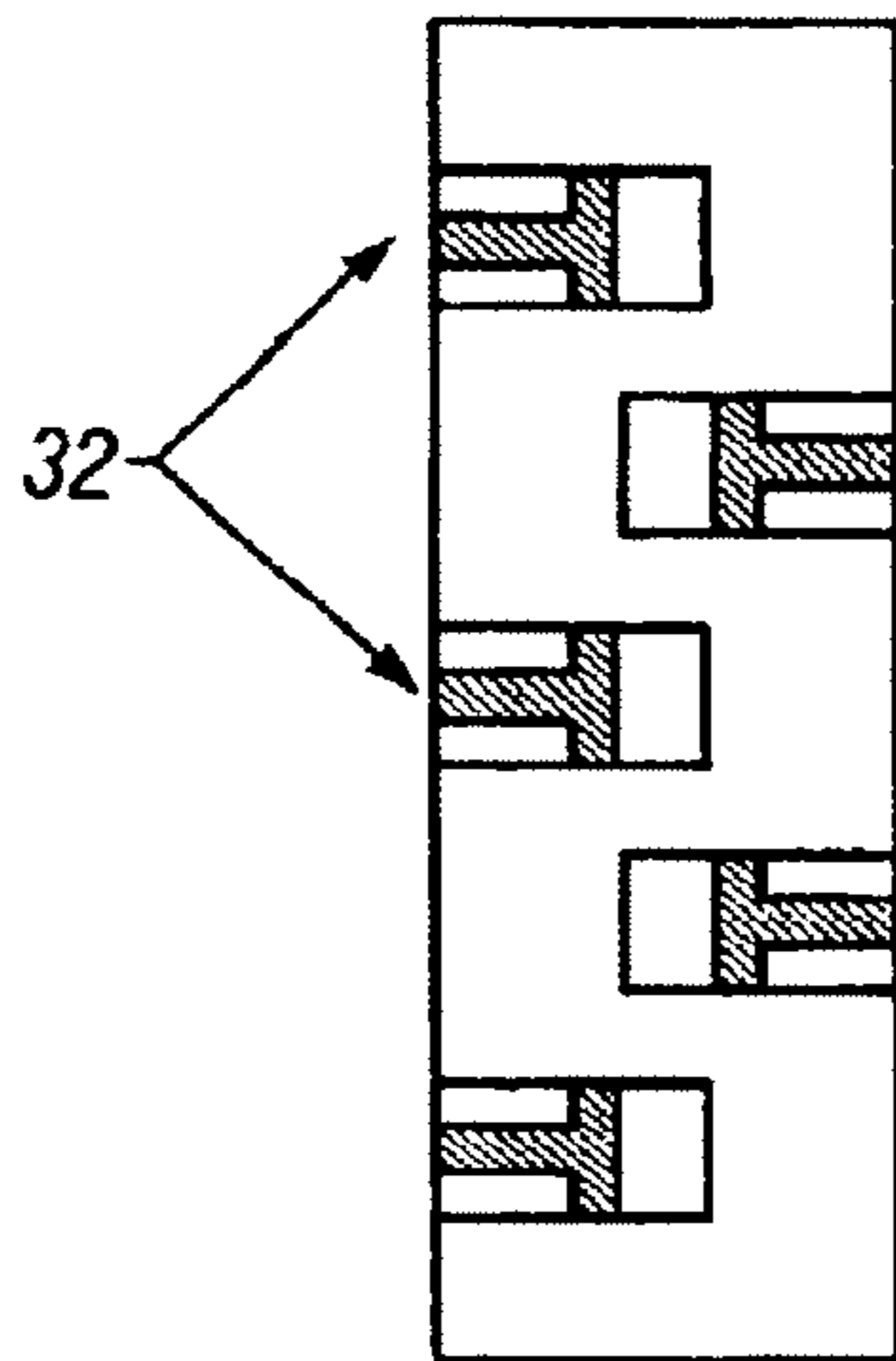

FIG. 8A

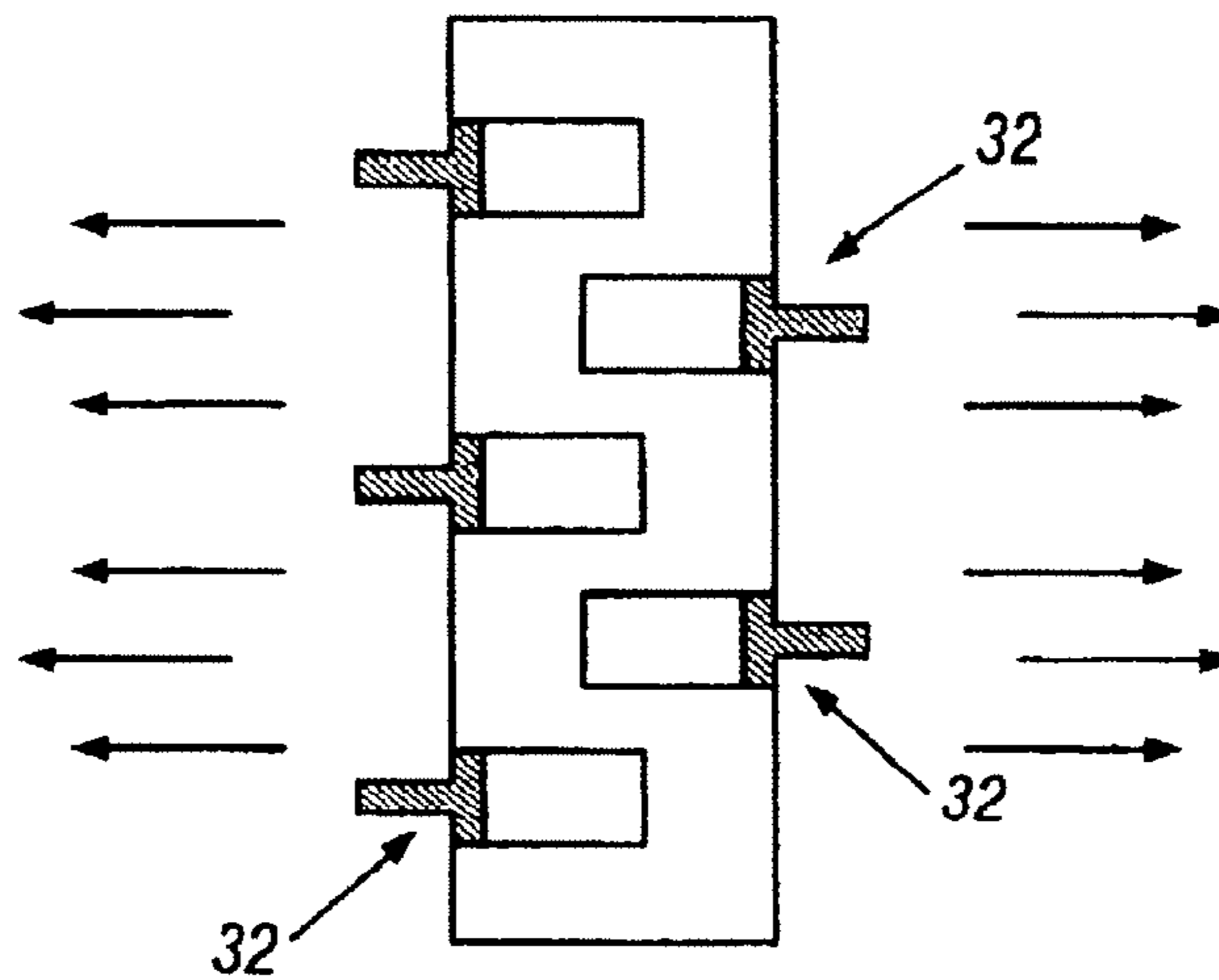

FIG. 8B

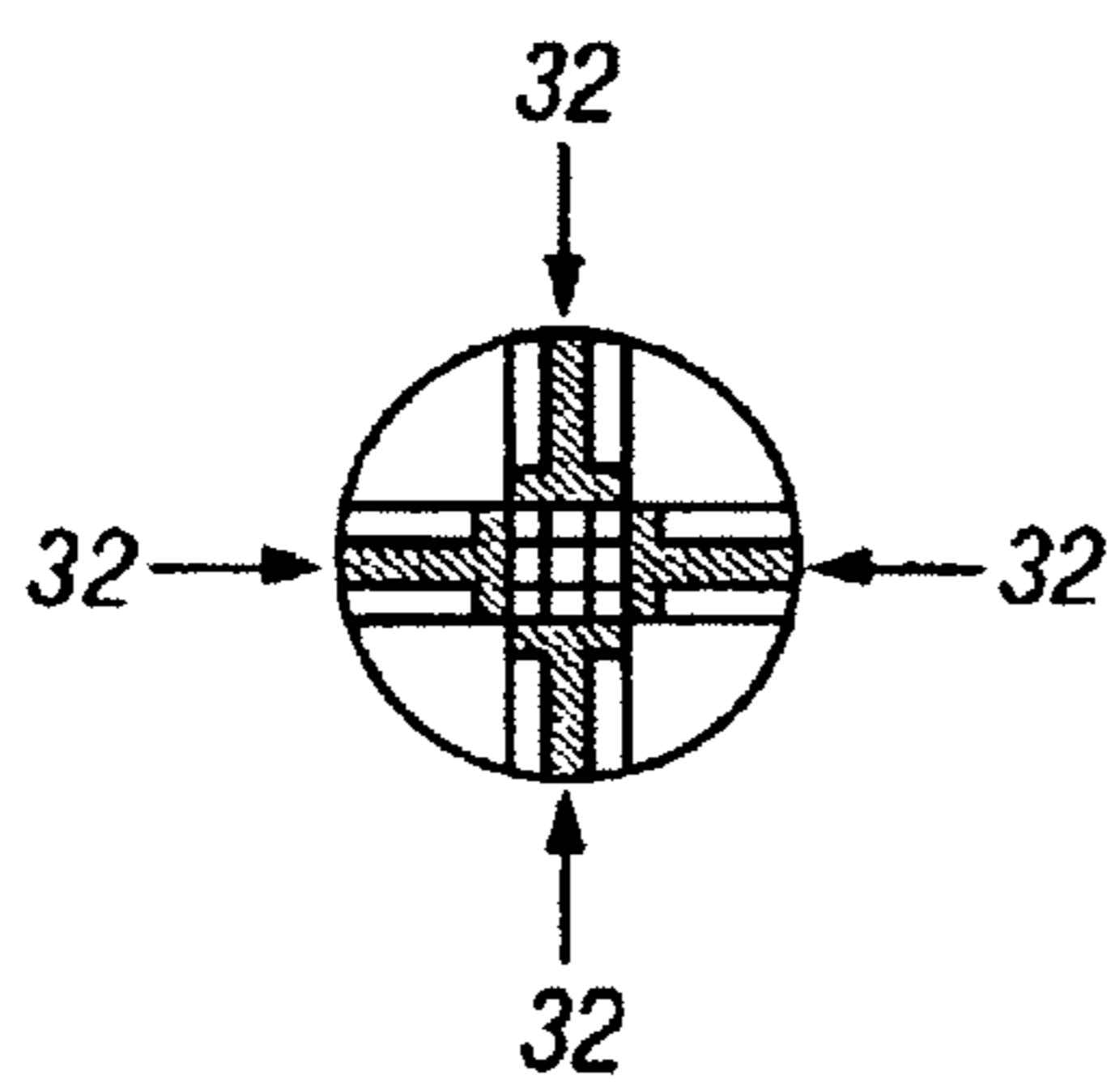

FIG. 8C

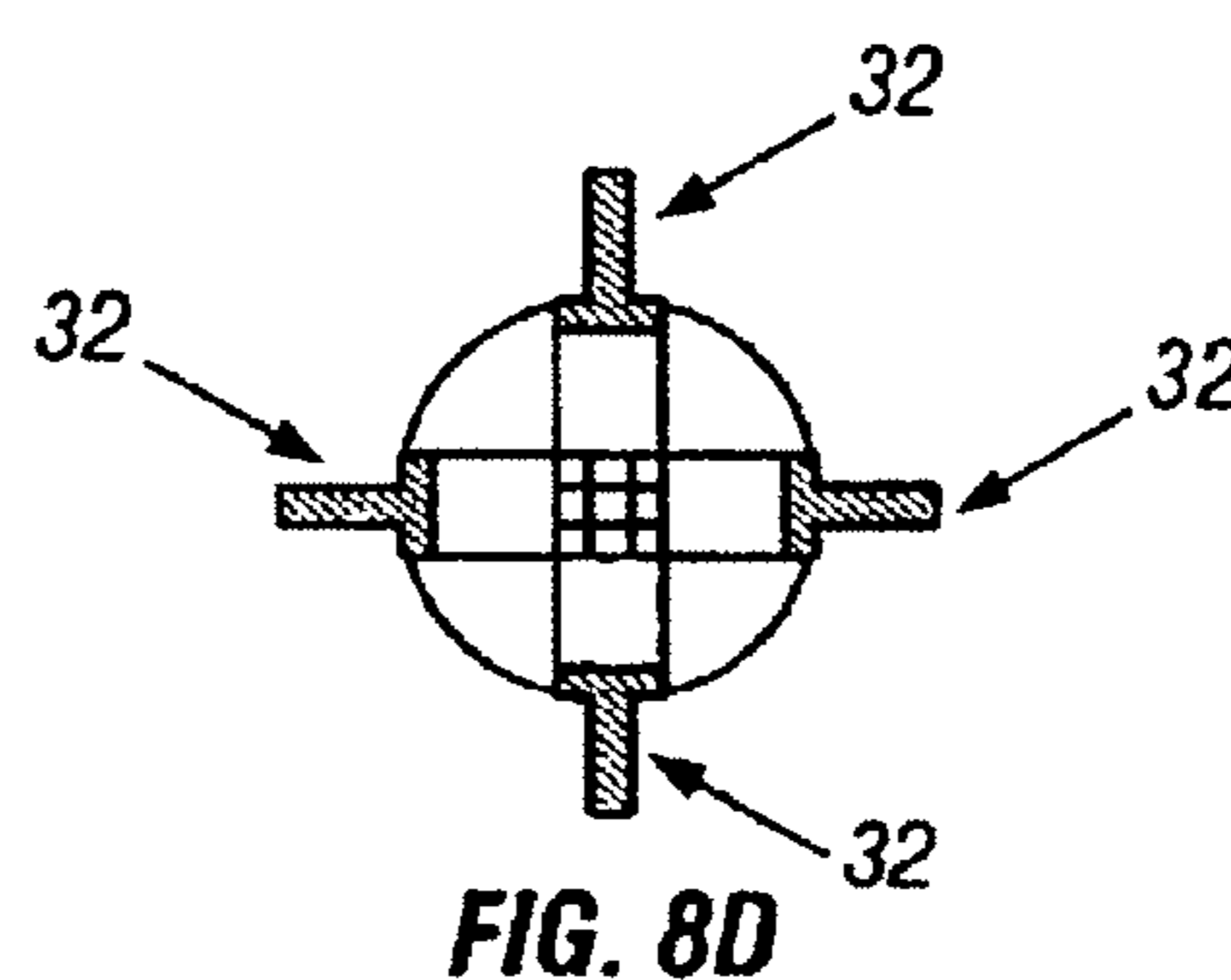

FIG. 8D

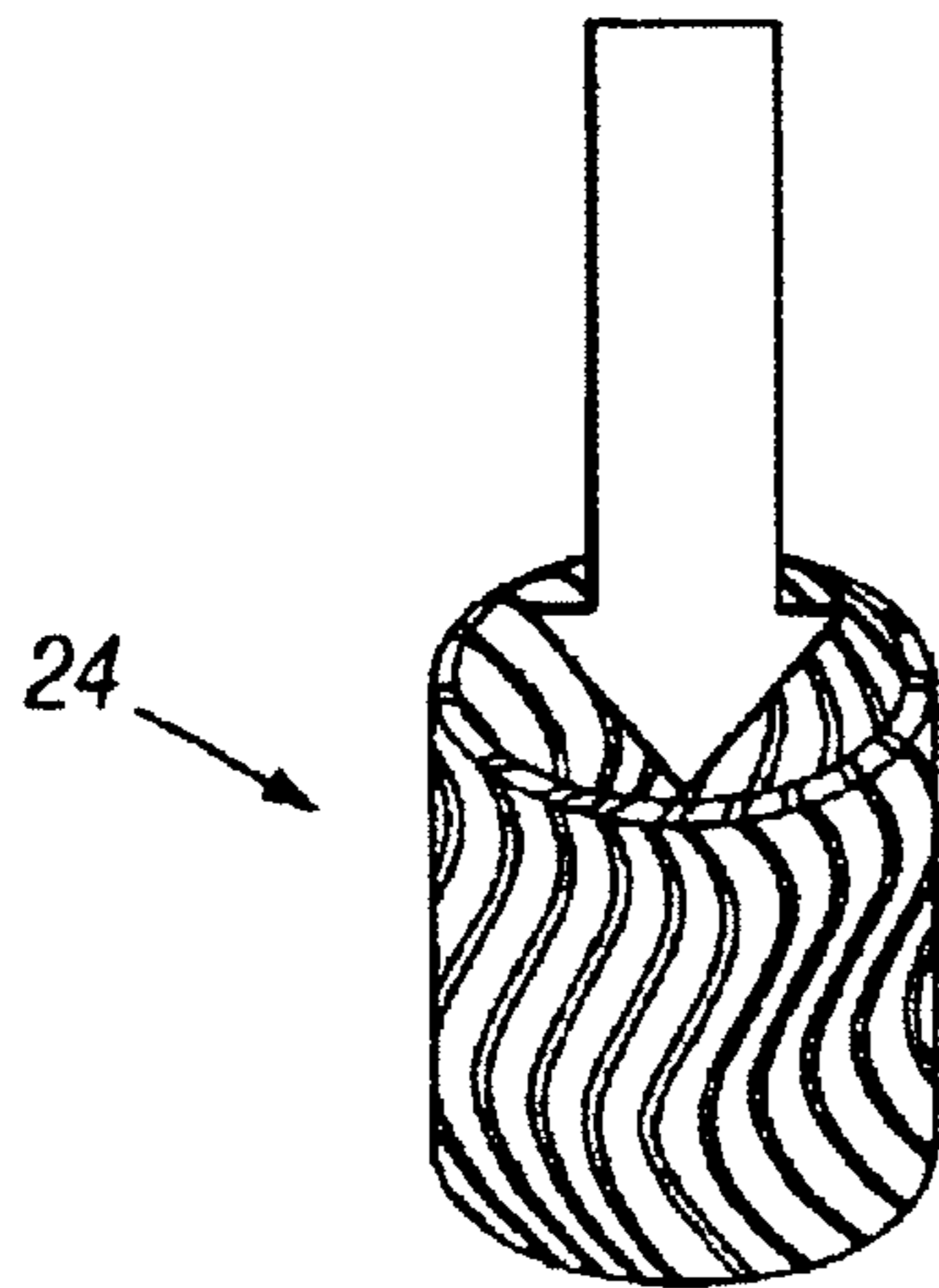
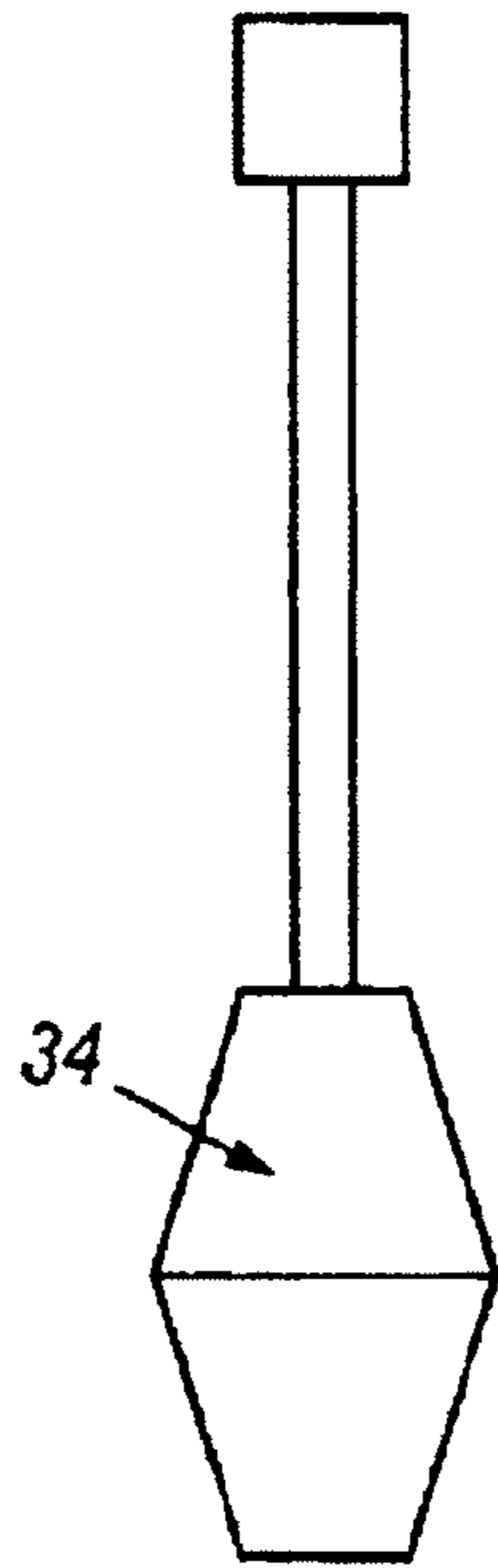

FIG. 9A

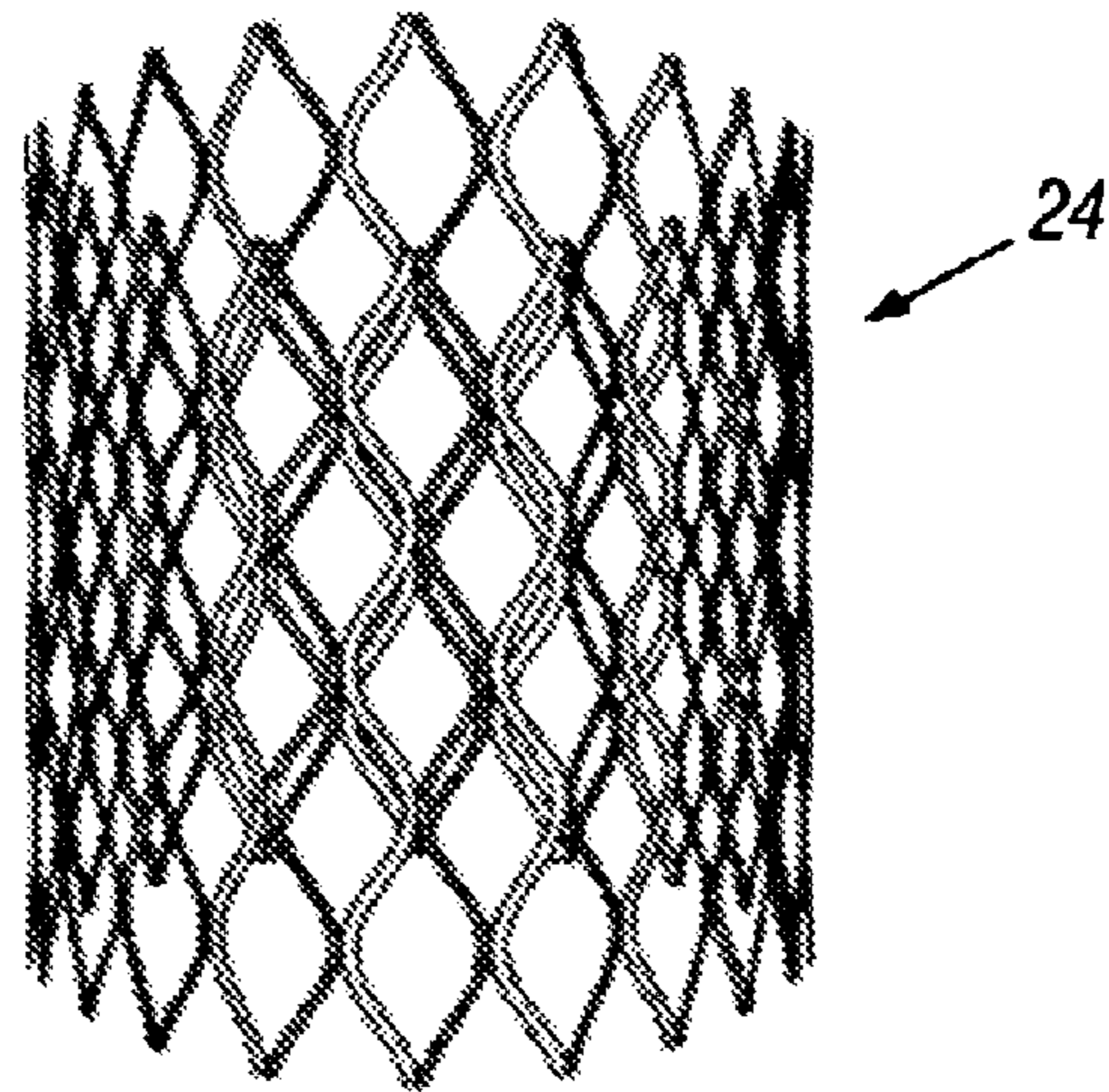

FIG. 9B

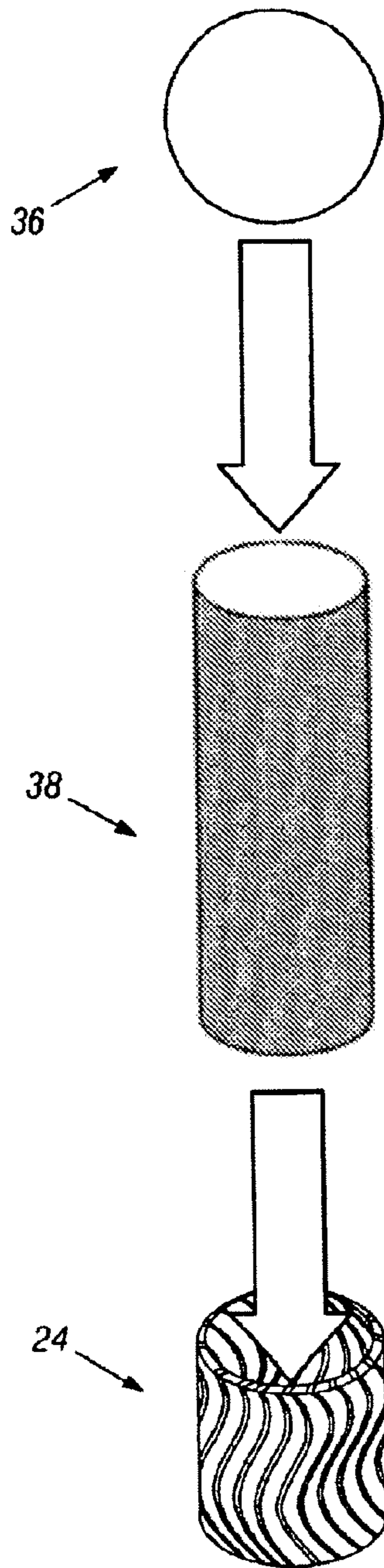

FIG. 10A

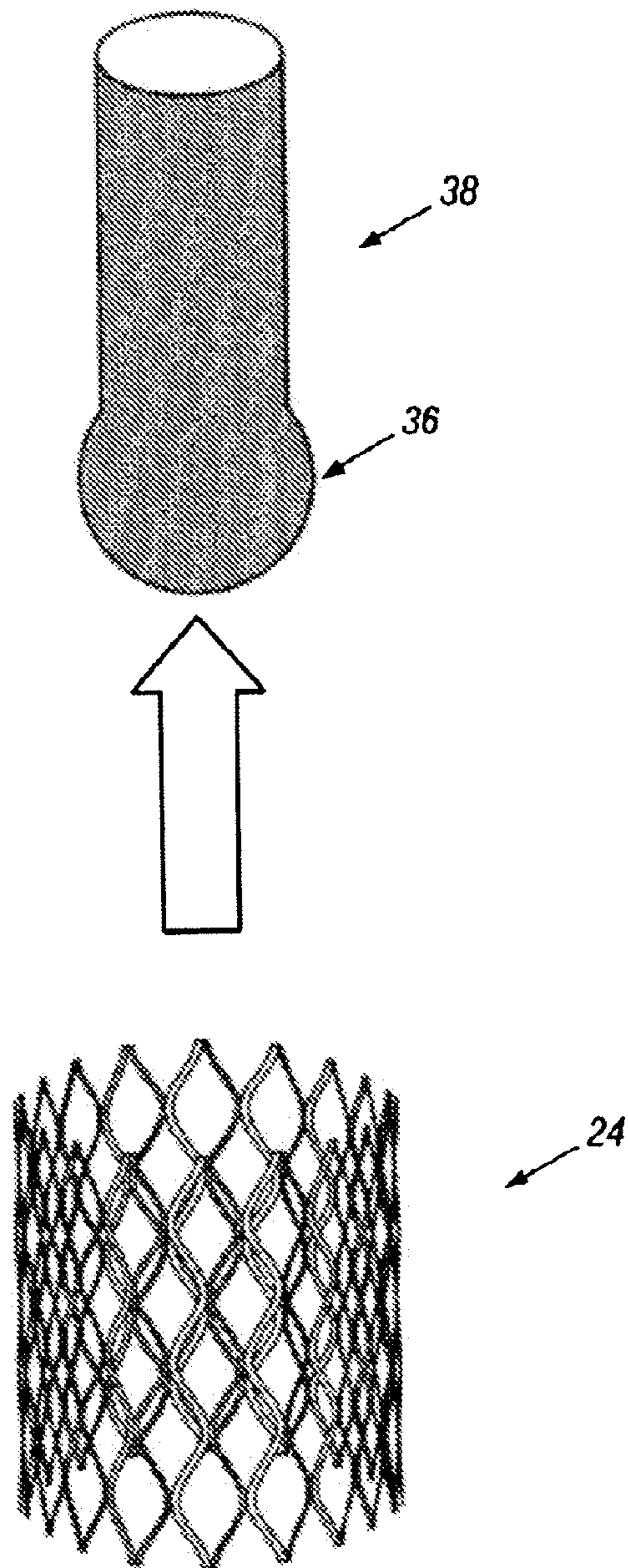

FIG. 10B

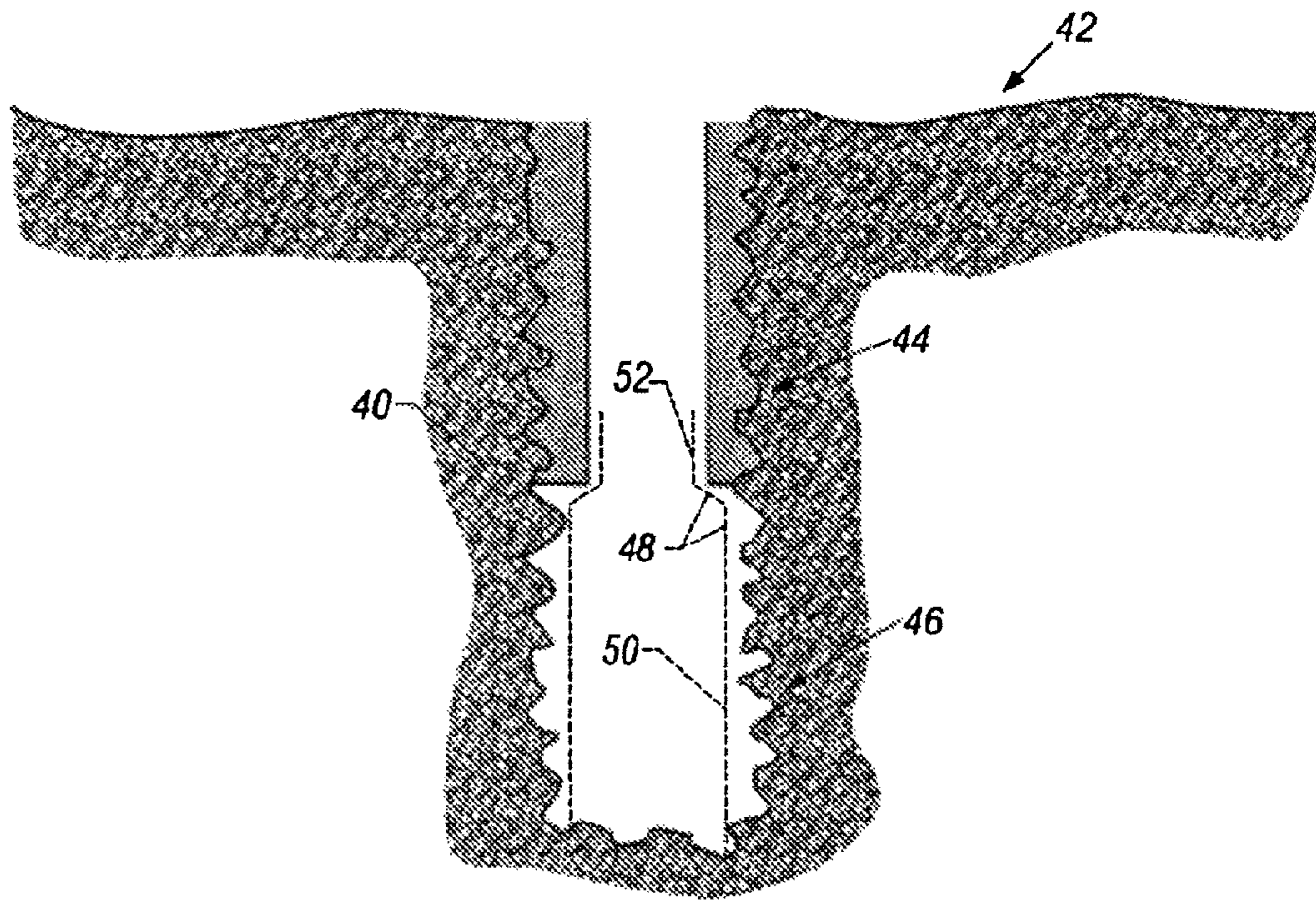

FIG. 11

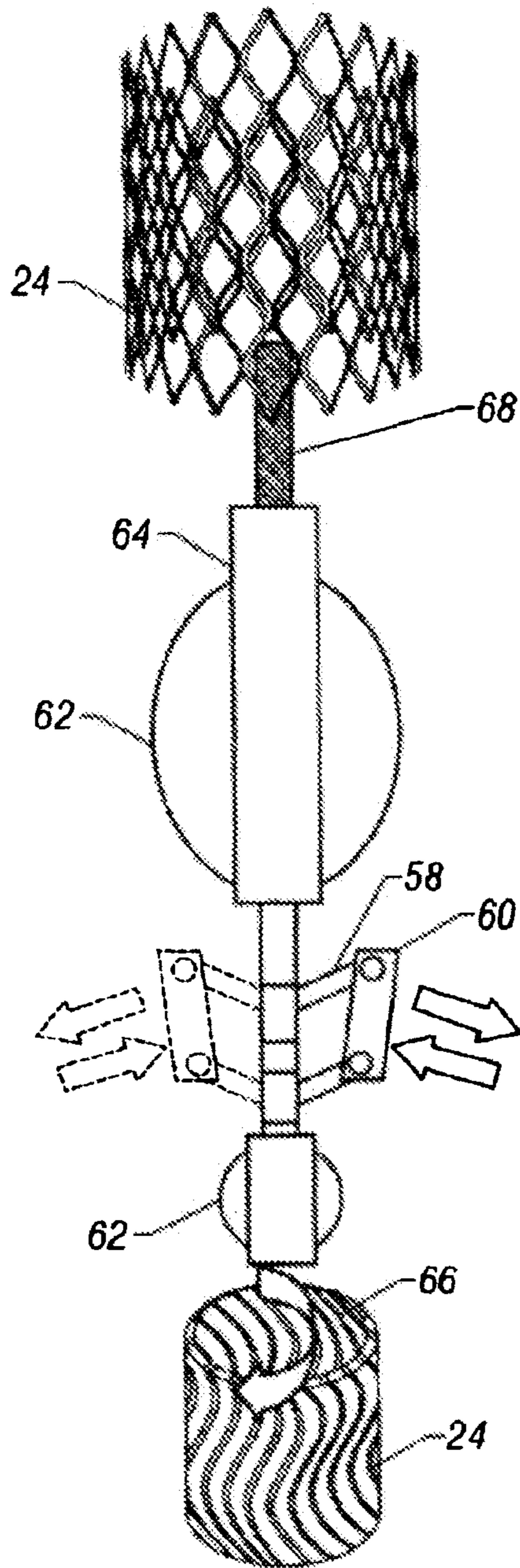

FIG. 12

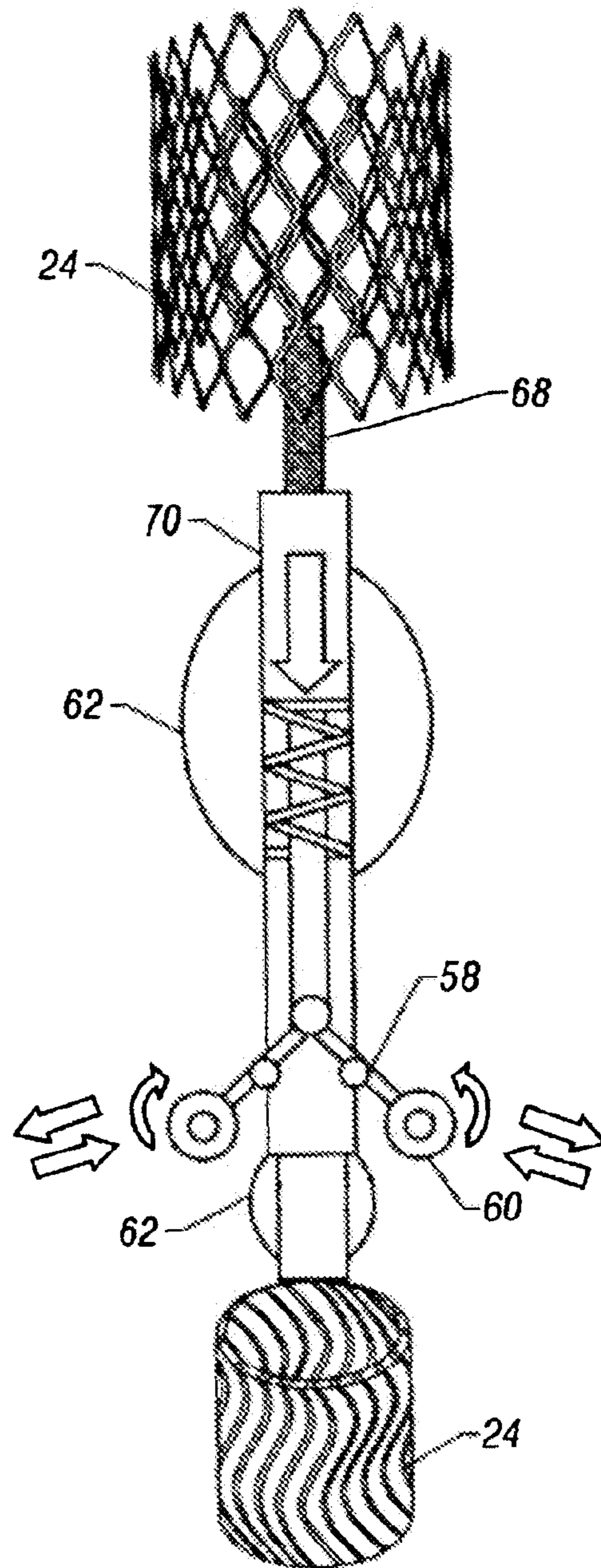

FIG. 13

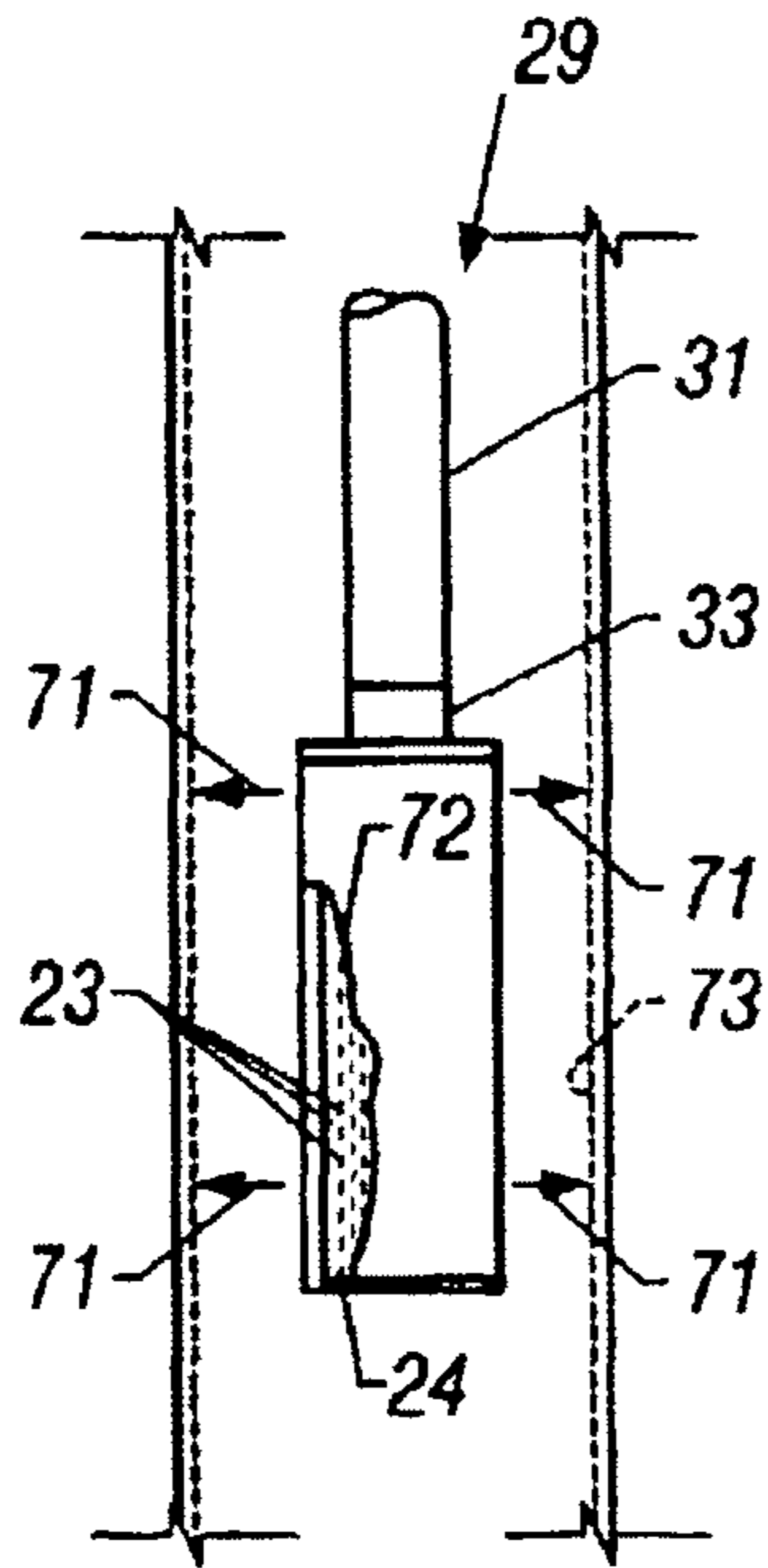

FIG. 14

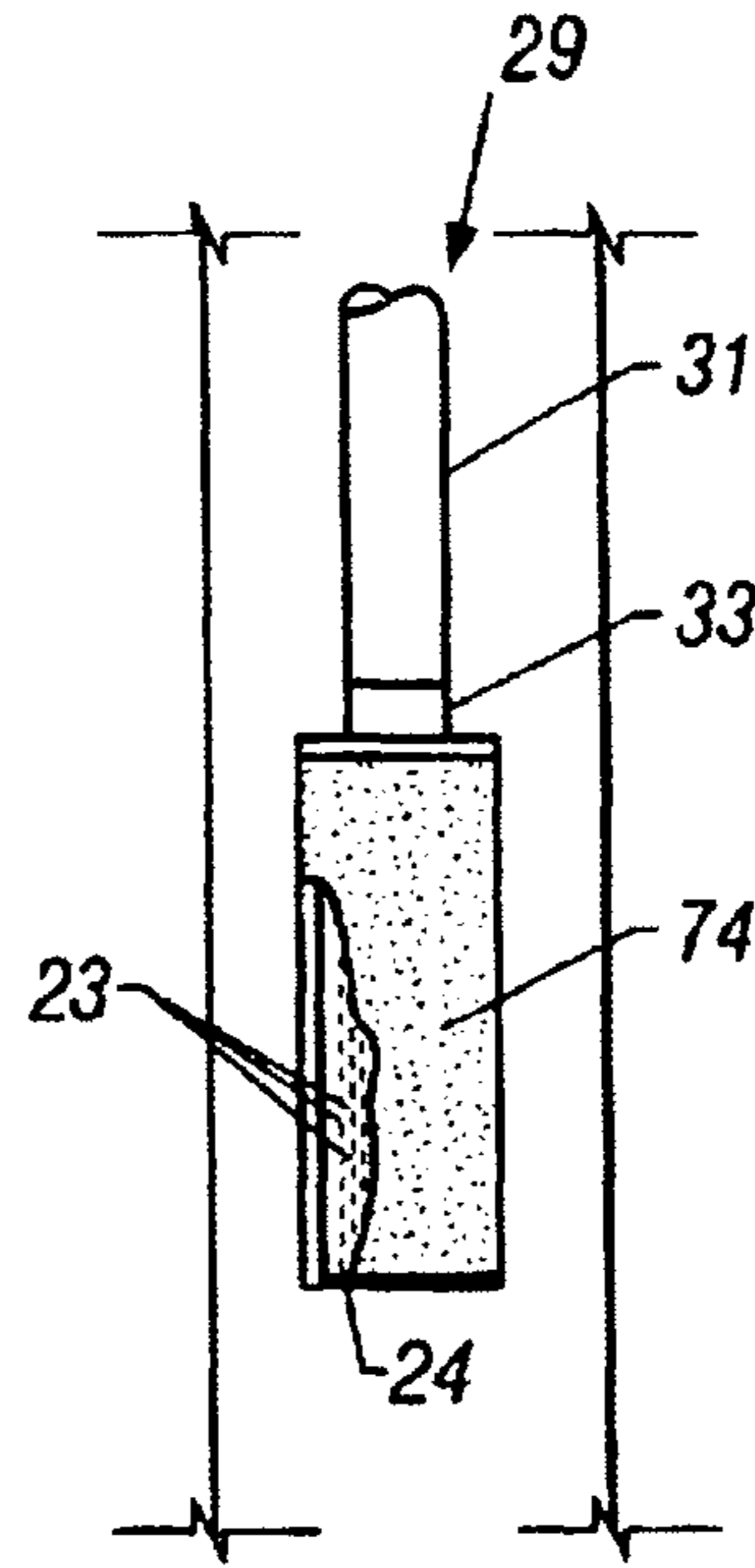

FIG. 14A

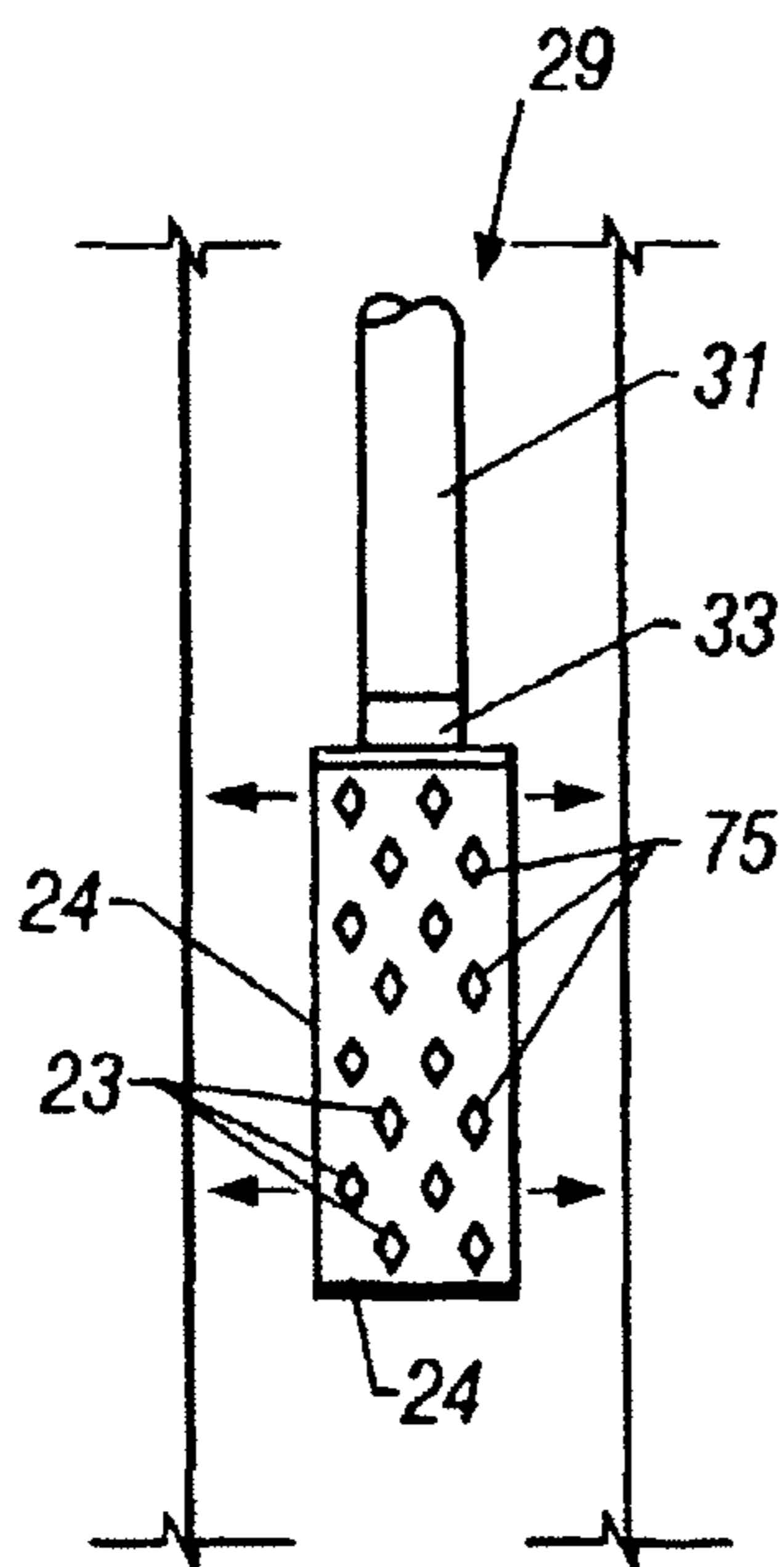

FIG. 14B

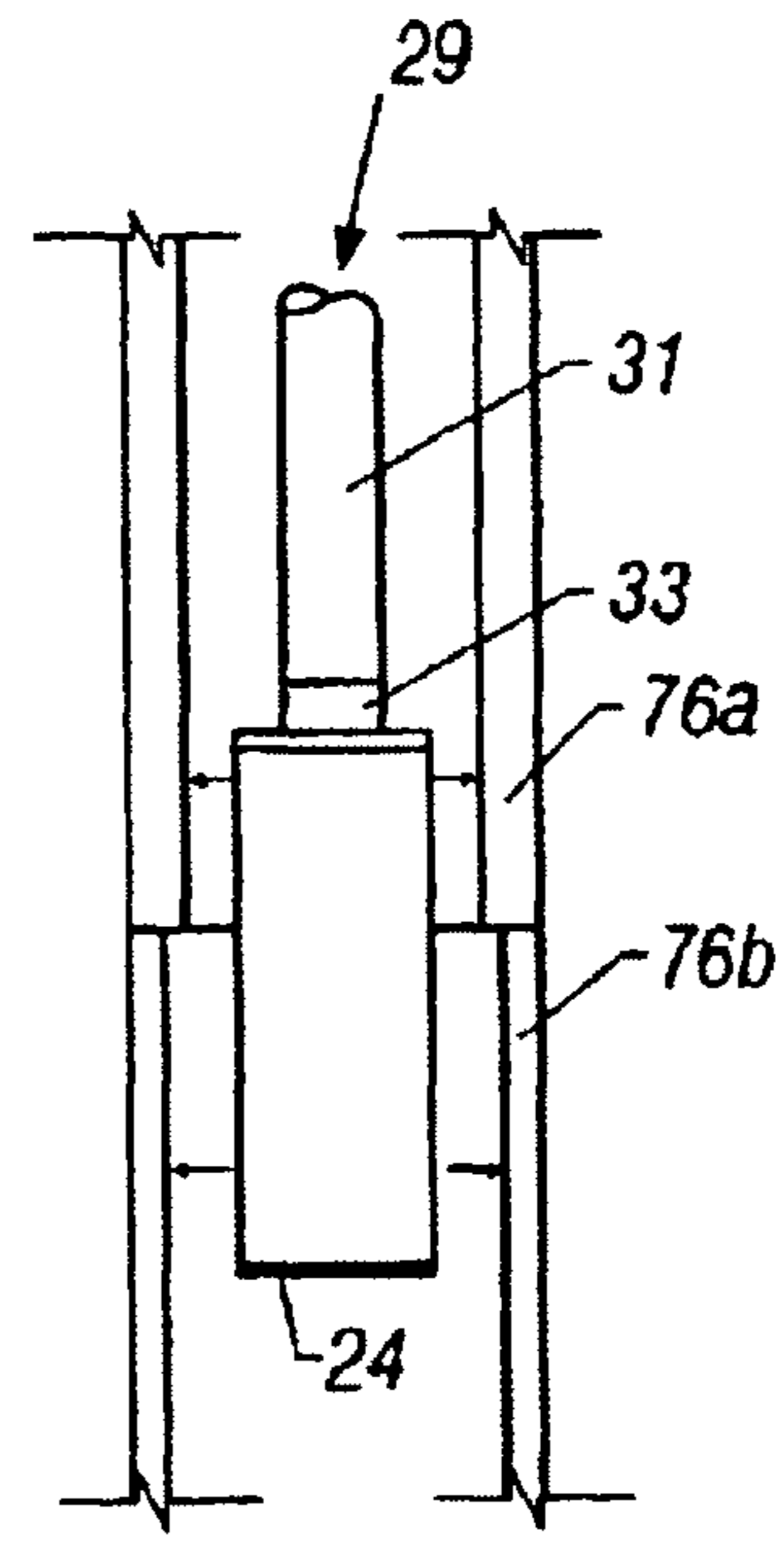

FIG. 14C

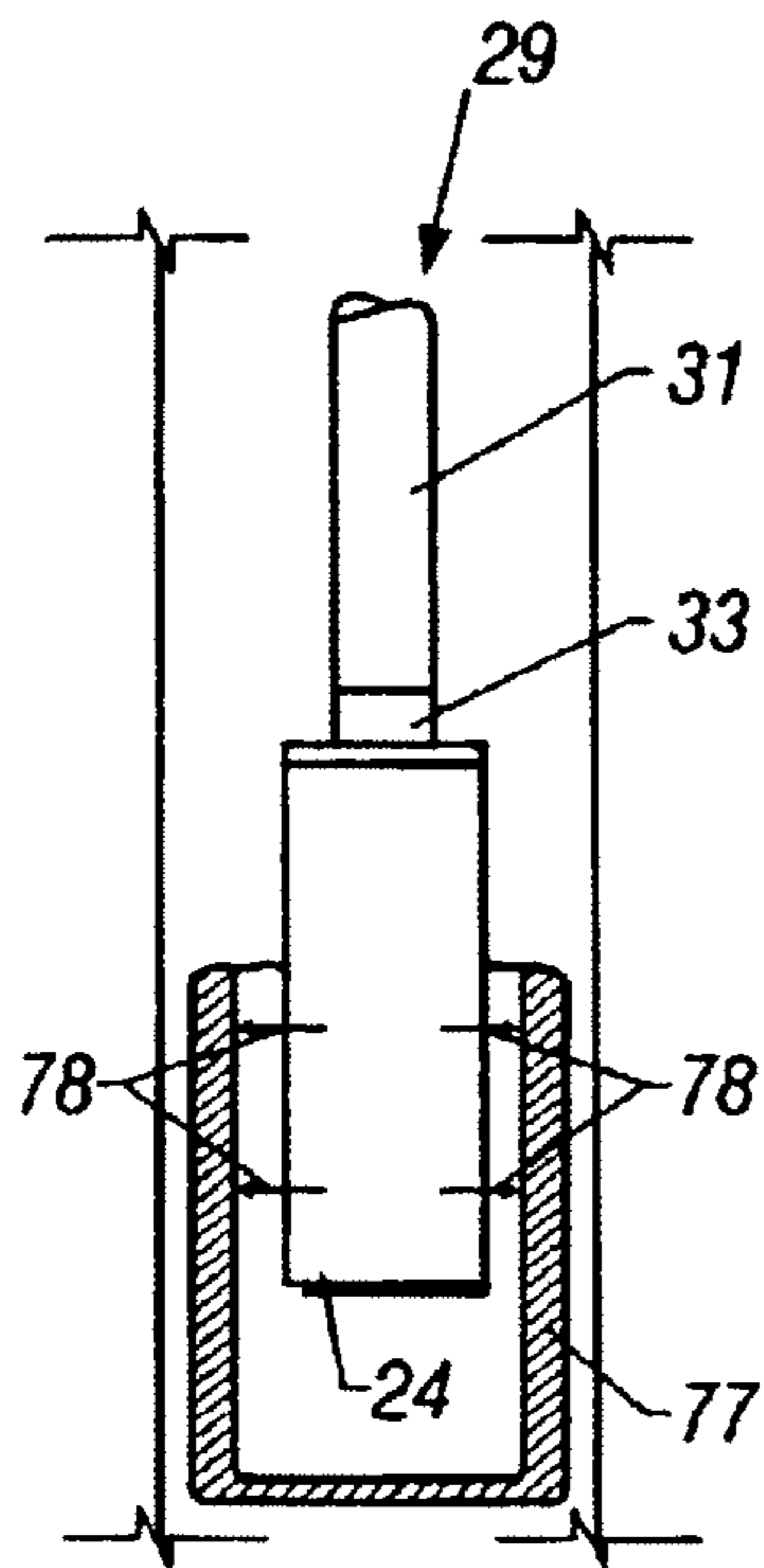

FIG. 14D

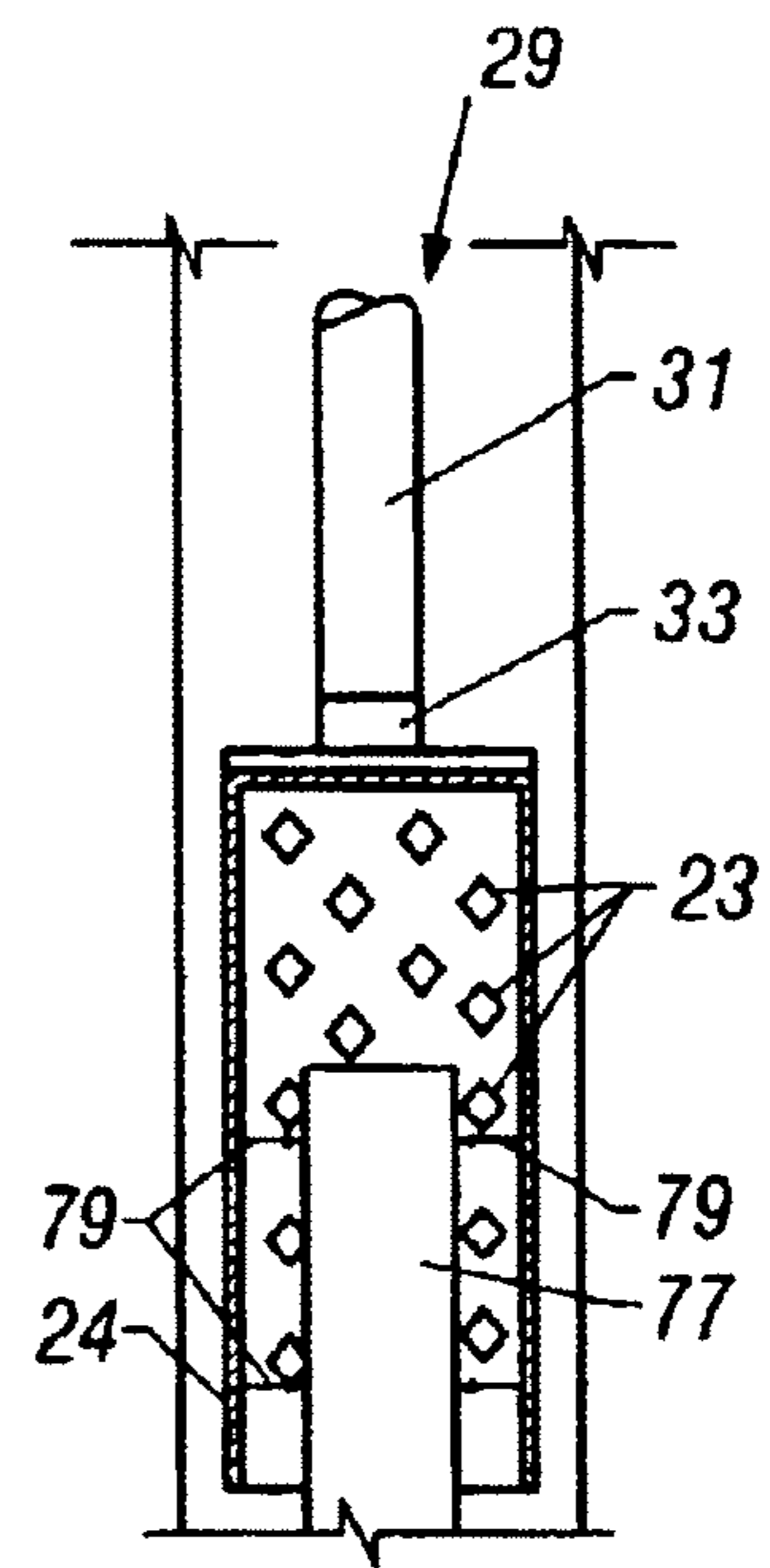

FIG. 14E

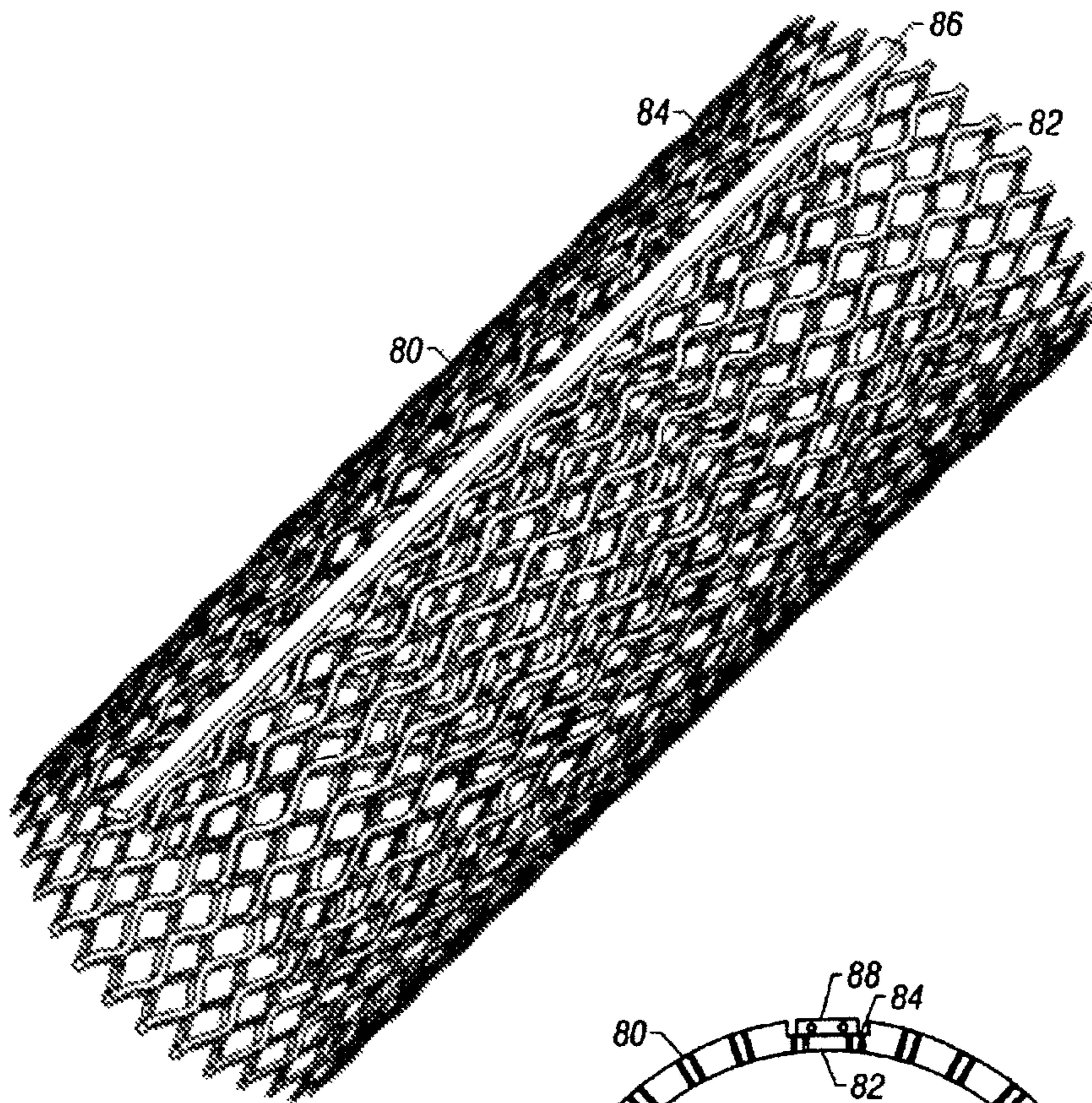

FIG. 15

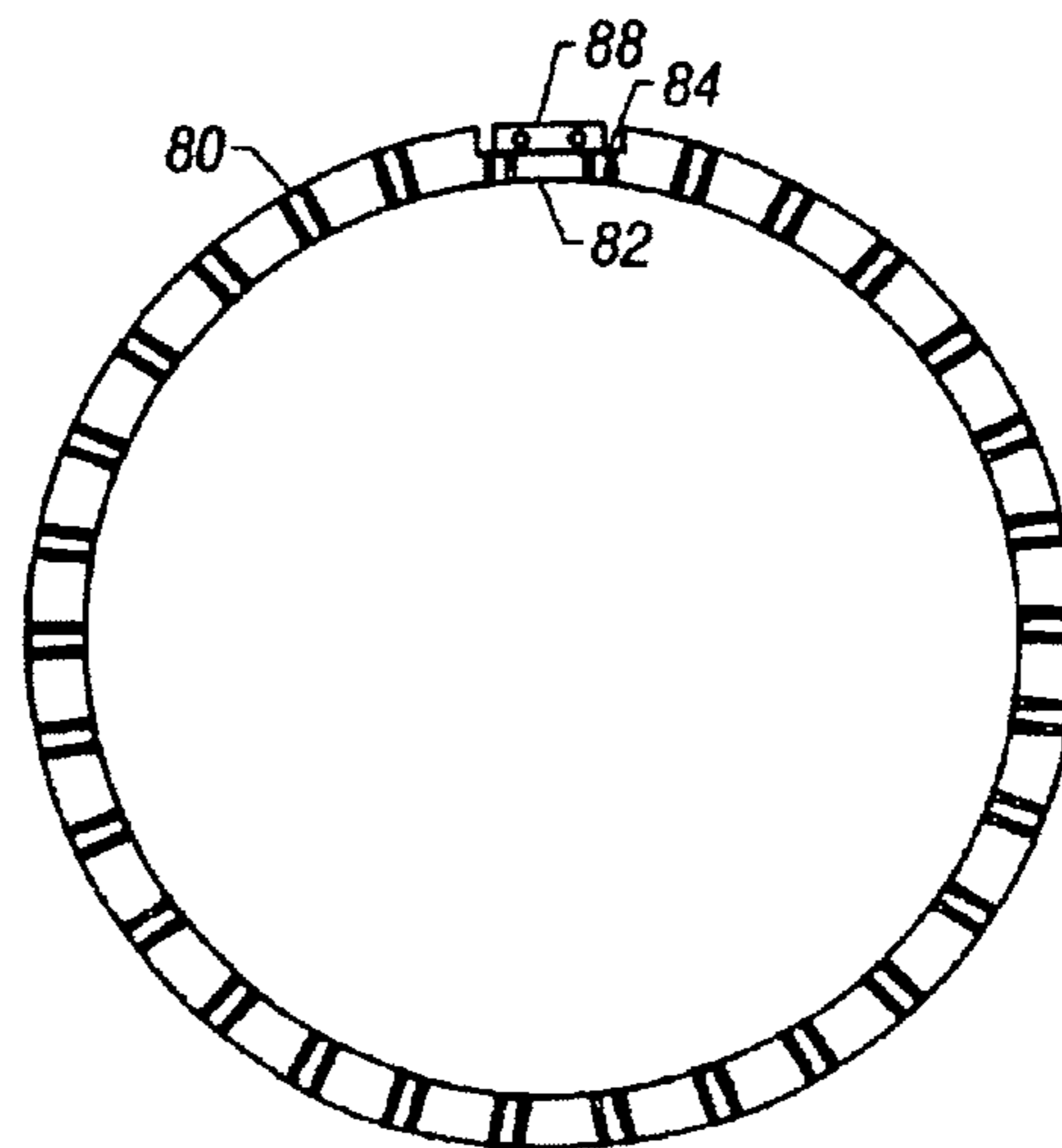
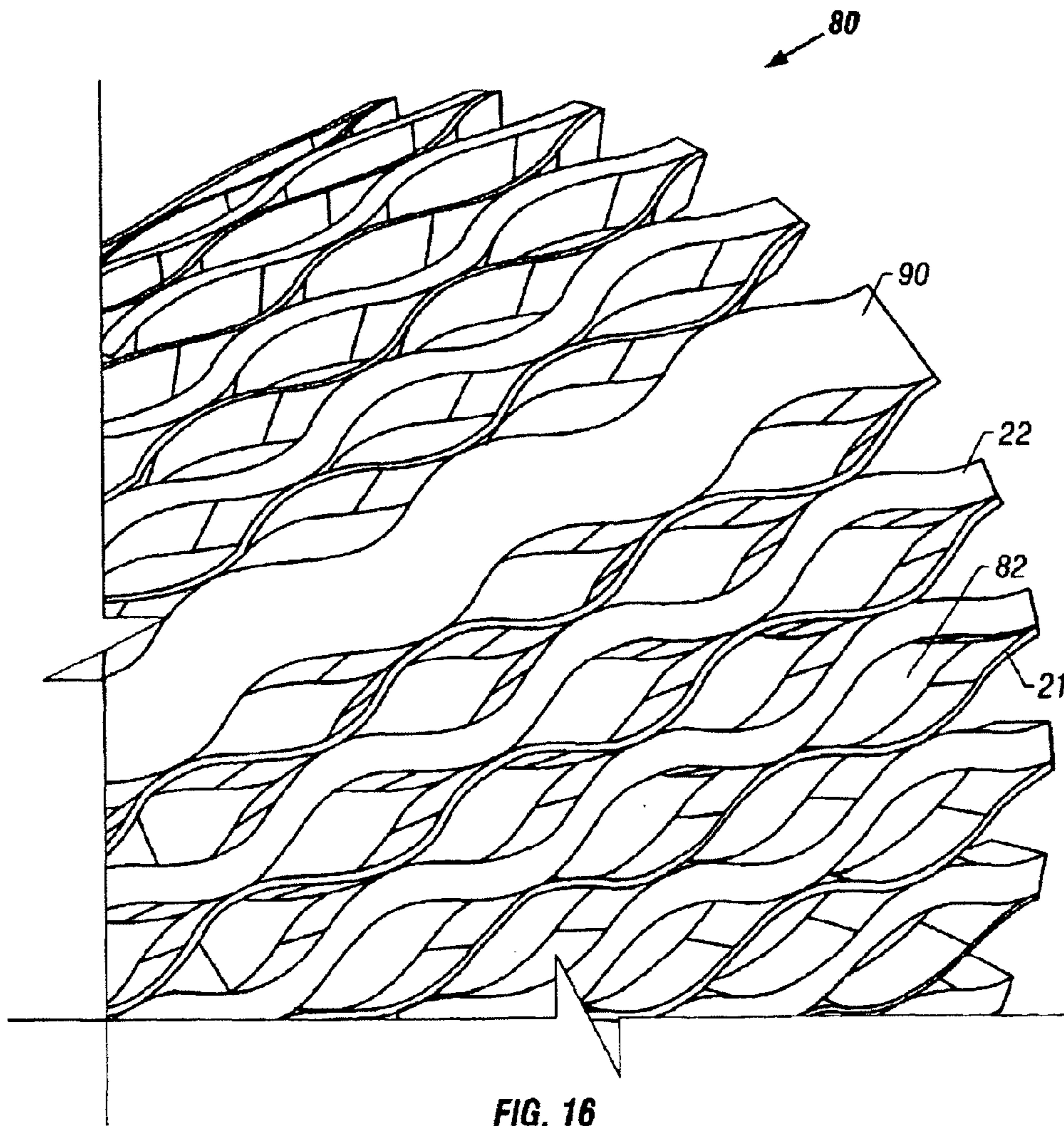

FIG. 15A



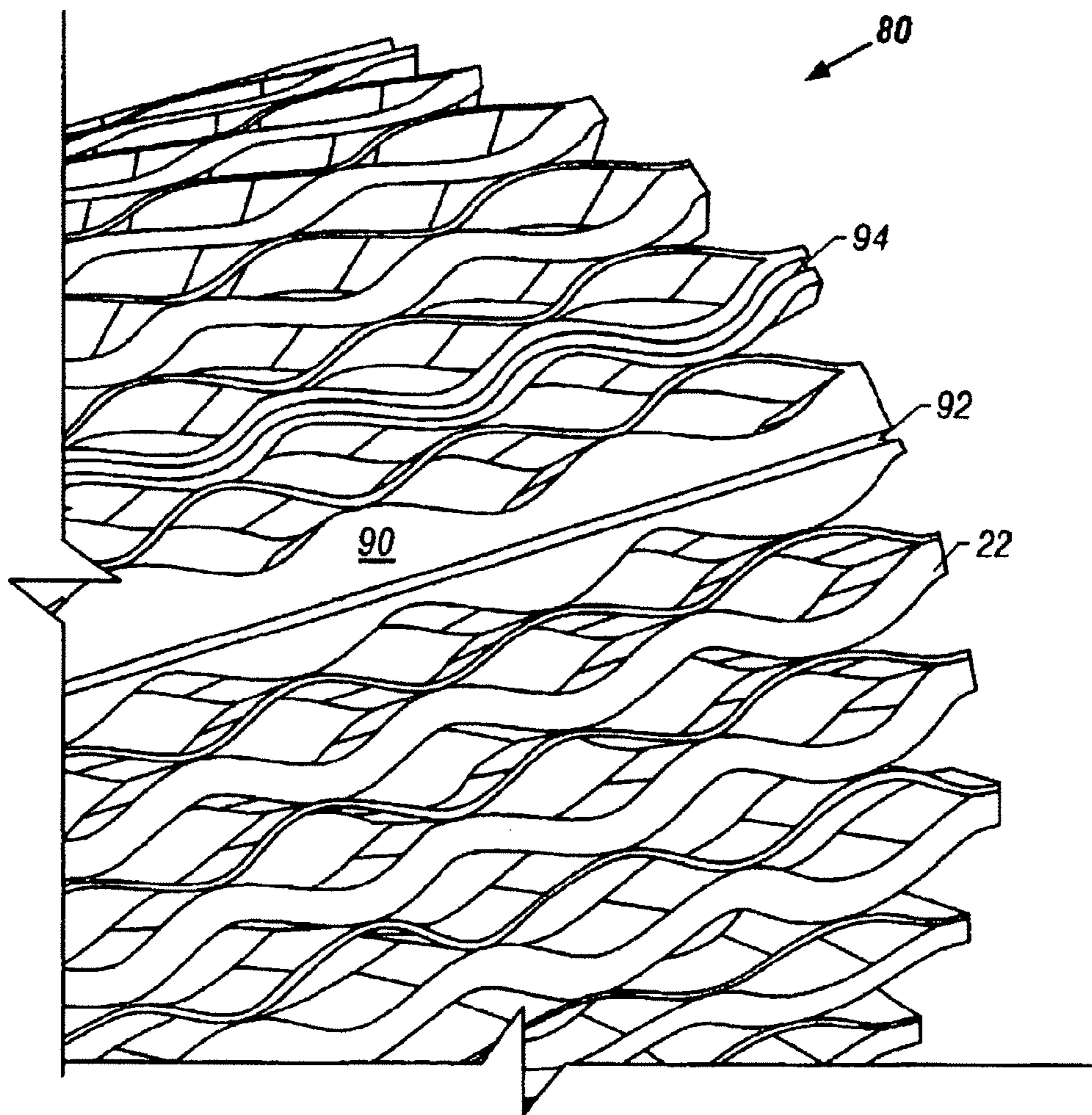

FIG. 17A

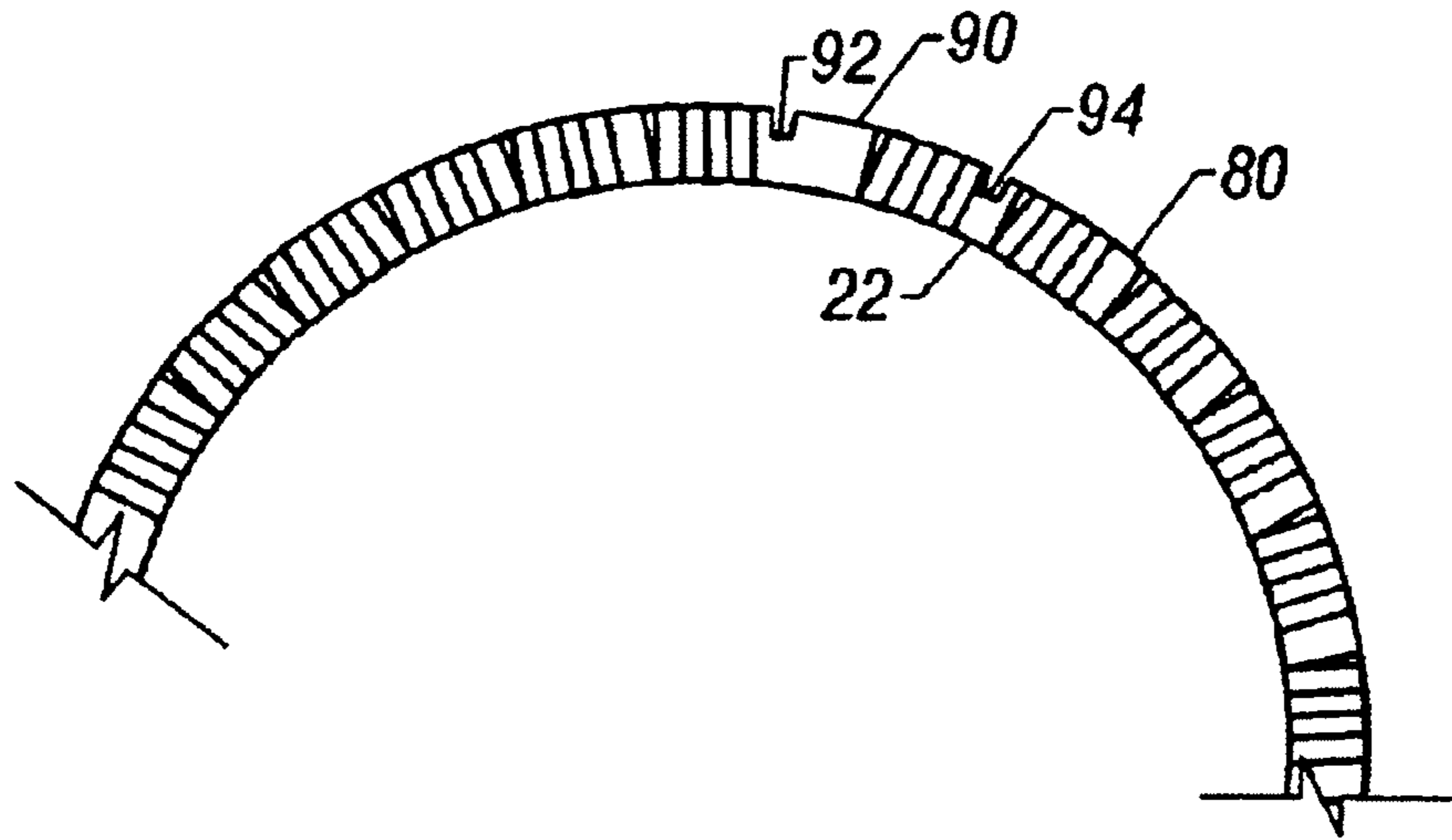

FIG. 17B

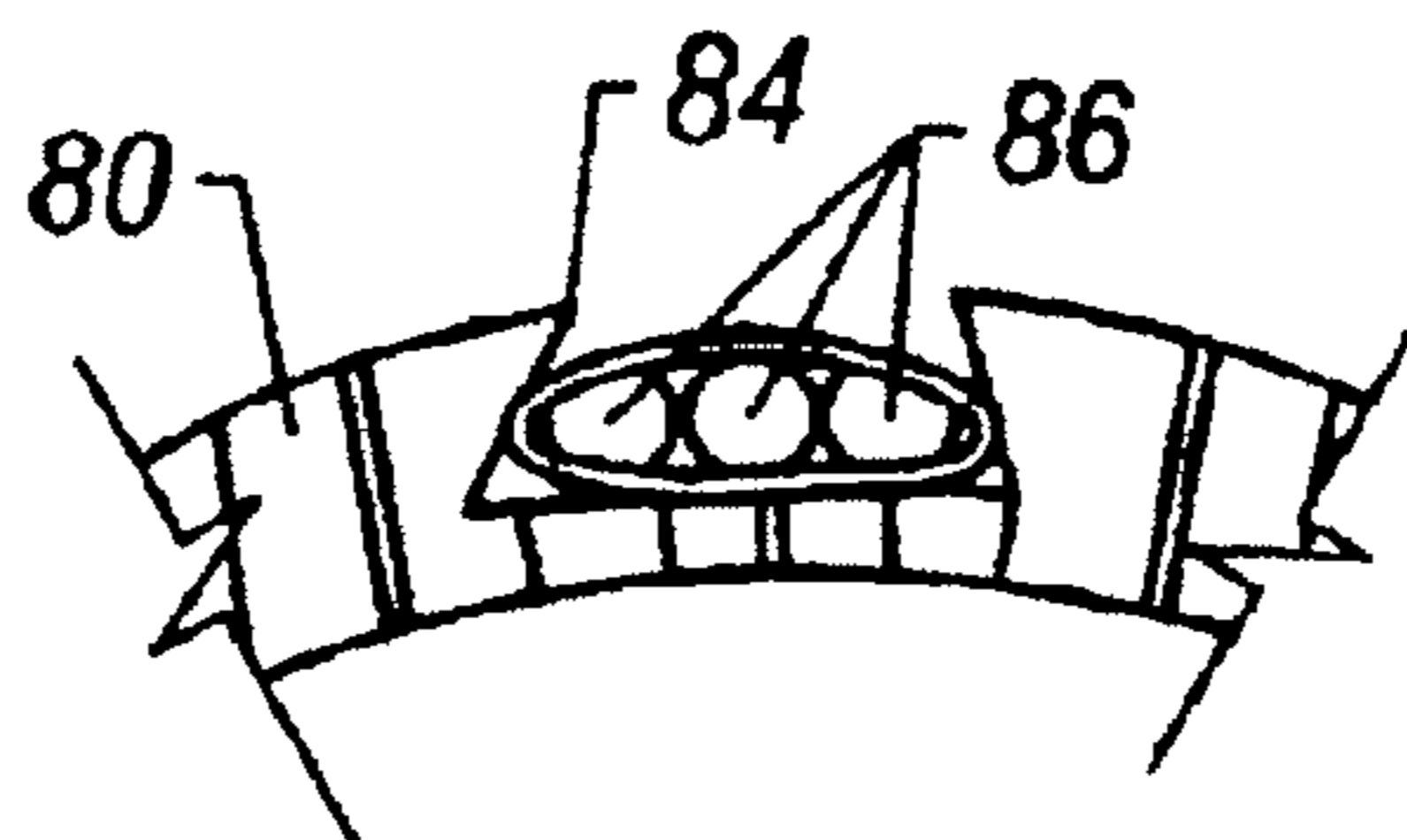

FIG. 18

EXPANDABLE TUBING AND METHOD

Matter enclosed in heavy brackets [] appears in the original patent but forms no part of this reissue specification; matter printed in italics indicates the additions made by reissue.

CROSS REFERENCE TO RELATED APPLICATIONS

The following is based on and claims the priority of provisional application No. 60/242,276 filed Oct. 20, 2000 and provisional application No. 60/263,941 filed Jan. 24, 2001.

FIELD OF THE INVENTION

This invention relates to equipment that can be used in the drilling and completion of wellbores in an underground formation and in the production of fluids from such wells.

BACKGROUND OF THE INVENTION

Fluids such as oil, natural gas and water are obtained from a subterranean geologic formation (a "reservoir") by drilling a well that penetrates the fluid-bearing formation. Once the well has been drilled to a certain depth the borehole wall must be supported to prevent collapse. Conventional well drilling methods involve the installation of a casing string and cementing between the casing and the borehole to provide support for the borehole structure. After cementing a casing string in place, the drilling to greater depths can commence. After each subsequent casing string is installed, the next drill bit must pass through the inner diameter of the casing. In this manner each change in casing requires a reduction in the borehole diameter. This repeated reduction in the borehole diameter creates a need for very large initial borehole diameters to permit a reasonable pipe diameter at the depth where the wellbore penetrates the producing formation. The need for larger boreholes and multiple casing strings results in more time, material and expense being used than if a uniform size borehole could be drilled from the surface to the producing formation.

Various methods have been developed to stabilize or complete uncased boreholes. U.S. Pat. No. 5,348,095 to Worrall et al. discloses a method involving the radial expansion of a casing string to a configuration with a larger diameter. Very large forces are needed to impart the radial deformation desired in this method. In an effort to decrease the forces needed to expand the casing string, methods that involve expanding a liner that has longitudinal slots cut into it have been proposed (U.S. Pat. Nos. 5,366,012 and 5,667,011). These methods involve the radial deformation of the slotted liner into a configuration with an increased diameter by running an expansion mandrel through the slotted liner. These methods still require significant amounts of force to be applied throughout the entire length of the slotted liner.

A problem sometimes encountered while drilling a well is the loss of drilling fluids into subterranean zones. The loss of drilling fluids usually leads to increased expenses but can result in a borehole collapse and a costly "fishing" job to recover the drill string or other tools that were in the well. Various additives are commonly used within the drilling fluids to help seal off loss circulation zones, such as cottonseed hulls or synthetic fibers.

Once a well is put in production an influx of sand from the producing formation can lead to undesired fill within the

wellbore and can damage valves and other production related equipment. Many methods have been attempted for sand control.

The present invention is directed to overcoming, or at least reducing the effects of one or more of the problems set forth above, and can be useful in other applications as well.

SUMMARY OF THE INVENTION

According to the present invention, a technique is provided for use of an expandable bistable device in a borehole. The bistable device is stable in a first contracted configuration and a second expanded configuration. An exemplary device is generally tubular, having a larger diameter in the expanded configuration than in the contracted configuration. The technique also may utilize a conveyance mechanism able to transport the bistable device to a location in a subterranean borehole. Furthermore, the bistable device can be constructed in various configurations for a variety of applications.

BRIEF DESCRIPTION OF THE DRAWINGS

The invention will hereafter be described with reference to the accompanying drawings, wherein like reference numerals denote like elements, and:

FIGS. 1A and 1B are illustrations of the forces imposed to make a bistable structure;

FIGS. 2A and 2B show force-deflection curves of two bistable structures;

FIGS. 3A-3F illustrate expanded and collapsed states of three bistable cells with various thickness ratios;

FIGS. 4A and 4B illustrate a bistable expandable tubular in its expanded and collapsed states;

FIGS. 4C and 4D illustrate a bistable expandable tubular in collapsed and expanded states within a wellbore;

FIGS. 5A and 5B illustrate an expandable packer type of deployment device;

FIGS. 6A and 6B illustrate a mechanical packer type of deployment device;

FIGS. 7A-7D illustrate an expandable swage type of deployment device;

FIGS. 8A-8D illustrate a piston type of deployment device;

FIGS. 9A and 9B illustrate a plug type of deployment device;

FIGS. 10A and 10B illustrate a ball type of deployment device;

FIG. 11 is a schematic of a wellbore utilizing an expandable bistable tubular;

FIG. 12 illustrates a motor driven radial roller deployment device; and

FIG. 13 illustrates a hydraulically driven radial roller deployment device.

FIG. 14 illustrates a bistable expandable tubular having a wrapping;

FIG. 14A is a view similar to FIG. 14 in which the wrapping comprises a screen;

FIG. 14B is a view similar to FIG. 14 showing another alternate embodiment;

FIG. 14C is a view similar to FIG. 14 showing another alternate embodiment;

FIG. 14D is a view similar to FIG. 14 showing another alternate embodiment;

FIG. 14E is a view similar to FIG. 14 showing another alternate embodiment;

FIG. 15 is a perspective view of an alternative embodiment of the present invention.

3

FIG. 15A is a cross-sectional view of an alternative embodiment of the present invention.

FIG. 16 is a partial perspective view of an alternative embodiment of the present invention.

FIGS. 17A-B are a partial perspective view and a partial cross-sectional end view respectively of an alternative embodiment of the present invention.

FIG. 18 is a partial cross-sectional end view of an alternative embodiment of the present invention.

While the invention is susceptible to various modifications and alternative forms, specific embodiments thereof have been shown by way of example in the drawings and are herein described in detail. It should be understood, however, that the description herein of specific embodiments is not intended to limit the invention to the particular forms disclosed, but on the contrary, the intention is to cover all modifications, equivalents, and alternatives falling within the spirit and scope of the invention as defined by the appended claims.

DETAILED DESCRIPTION OF EXEMPLARY EMBODIMENTS

Bistable devices used in the present invention can take advantage of a principle illustrated in FIGS. 1A and 1B. FIG. 1A shows a rod 10 fixed at each end to rigid supports 12. If the rod 10 is subjected to an axial force it begins to deform as shown in FIG. 1B. As the axial force is increased rod 10 ultimately reaches its Euler buckling limit and deflects to one of the two stable positions shown as 14 and 15. If the buckled rod is now clamped in the buckled position, a force at right angles to the long axis can cause the rod to move to either of the stable positions but to no other position. When the rod is subjected to a lateral force it must move through an angle β before deflecting to its new stable position.

Bistable systems are characterized by a force deflection curve such as those shown in FIGS. 2A and 2B. The externally applied force 16 causes the rod 10 of FIG. 1B to move in the direction X and reaches a maximum 18 at the onset of shifting from one stable configuration to the other. Further deflection requires less force because the system now has a negative spring rate and when the force becomes zero the deflection to the second stable position is spontaneous.

The force deflection curve for this example is symmetrical and is illustrated in FIG. 2A. By introducing either a precurvature to the rod or an asymmetric cross section the force deflection curve can be made asymmetric as shown in FIG. 2B. In this system the force 19 required to cause the rod to assume one stable position is greater than the force 20 required to cause the reverse deflection. The force 20 must be greater than zero for the system to have bistable characteristics.

Bistable structures, sometimes referred to as toggle devices, have been used in industry for such devices as flexible discs, over center clamps, hold-down devices and quick release systems for tension cables (such as in sailboat rigging backstays).

Instead of using the rigid supports as shown in FIGS. 1A and 1B, a cell can be constructed where the restraint is provided by curved struts connected at each end as shown in FIGS. 3A-3F. If both struts 21 and 22 have the same thickness as shown in FIGS. 3A and 3B, the force deflection curve is linear and the cell lengthens when compressed from its open position FIG. 3B to its closed position FIG. 3A. If the cell struts have different thicknesses, as shown in FIGS. 3C-3F, the cell has the force deflection characteristics shown in FIG. 2B, and does not change in length when it moves between its two stable positions. An expandable bistable tubular can thus

4

be designed so that as the radial dimension expands, the axial length remains constant. In one example, if the thickness ratio is over approximately 2:1, the heavier strut resists longitudinal changes. By changing the ratio of thick-to-thin strut dimensions, the opening and closing forces can be changed. For example, FIGS. 3C and 3D illustrated a thickness ratio of approximately 3:1, and FIGS. 3E and 3F illustrate a thickness ratio of approximately 6:1.

An expandable bore bistable tubular, such as casing, a tube, a patch, or pipe, can be constructed with a series of circumferential bistable connected cells 23 as shown in FIGS. 4A and 4B, where each thin strut 21 is connected to a thick strut 22. The longitudinal flexibility of such a tubular can be modified by changing the length of the cells and by connecting each row of cells with a compliant link. Further, the force deflection characteristics and the longitudinal flexibility can also be altered by the design of the cell shape. FIG. 4A illustrates an expandable bistable tubular 24 in its expanded configuration while FIG. 4B illustrates the expandable bistable tubular 24 in its contracted or collapsed configuration. Within this application the term "collapsed" is used to identify the configuration of the bistable element or device in the stable state with the smallest diameter, it is not meant to imply that the element or device is damaged in any way. In the collapsed state, bistable tubular 24 is readily introduced into a wellbore 29, as illustrated in FIG. 4C. Upon placement of the bistable tubular 24 at a desired wellbore location, it is expanded, as illustrated in FIG. 4D.

The geometry of the bistable cells is such that the tubular cross-section can be expanded in the radial direction to increase the overall diameter of the tubular. As the tubular expands radially, the bistable cells deform elastically until a specific geometry is reached. At this point the bistable cells move, e.g. snap, to a final expanded geometry. With some materials and/or bistable cell designs, enough energy can be released in the elastic deformation of the cell (as each bistable cell snaps past the specific geometry) that the expanding cells are able to initiate the expansion of adjoining bistable cells past the critical bistable cell geometry. Depending on the deflection curves, a portion or even an entire length of bistable expandable tubular can be expanded from a single point.

In like manner if radial compressive forces are exerted on an expanded bistable tubular, it contracts radially and the bistable cells deform elastically until a critical geometry is reached. At this point the bistable cells snap to a final collapsed structure. In this way the expansion of the bistable tubular is reversible and repeatable. Therefore the bistable tubular can be a reusable tool that is selectively changed between the expanded state as shown in FIG. 4A and the collapsed state as shown in FIG. 4B.

In the collapsed state, as in FIG. 4B, the bistable expandable tubular is easily inserted into the wellbore and placed into position. A deployment device is then used to change the configuration from the collapsed state to the expanded state.

In the expanded state, as in FIG. 4A, design control of the elastic material properties of each bistable cell can be such that a constant radial force can be applied by the tubular wall to the constraining wellbore surface. The material properties and the geometric shape of the bistable cells can be designed to give certain desired results.

One example of designing for certain desired results is an expandable bistable tubular string with more than one diameter throughout the length of the string. This can be useful in boreholes with varying diameters, whether designed that way or as a result of unplanned occurrences such as formation washouts or keyseats within the borehole. This also can be beneficial when it is desired to have a portion of the bistable

5

expandable device located inside a cased section of the well while another portion is located in an uncased section of the well. FIG. 11 illustrates one example of this condition. A wellbore 40 is drilled from the surface 42 and comprises a cased section 44 and an openhole section 46. An expandable

bistable device 48 having segments 50, 52 with various diameters is placed in the well. The segment with a larger diameter 50 is used to stabilize the openhole section 46 of the well, while the segment having a reduced diameter 52 is located inside the cased section 44 of the well.

Bistable collars or connectors 24A (see FIG. 4C) can be designed to allow sections of the bistable expandable tubular to be joined together into a string of useful lengths using the same principle as illustrated in FIG. 4A and 4B. This bistable connector 24A also incorporates a bistable cell design that allows it to expand radially using the same mechanism as for the bistable expandable tubular component. Exemplary bistable connectors have a diameter slightly larger than the expandable tubular sections that are being joined. The bistable connector is then placed over the ends of the two sections and mechanically attached to the expandable tubular sections. Mechanical fasteners such as screws, rivets or bands can be used to connect the connector to the tubular sections. The bistable connector typically is designed to have an expansion rate that is compatible with the expandable tubular sections, so that it continues to connect the two sections after the expansion of the two segments and the connector.

Alternatively, the bistable connector can have a diameter smaller than the two expandable tubular sections joined. Then, the connector is inserted inside of the ends of the tubulars and mechanically fastened as discussed above. Another embodiment would involve the machining of the ends of the tubular sections on either their inner or outer surfaces to form an annular recess in which the connector is located. A connector designed to fit into the recess is placed in the recess. The connector would then be mechanically attached to the ends as described above. In this way the connector forms a relatively flush-type connection with the tubular sections.

A conveyance device 31 transports the bistable expandable tubular lengths and bistable connectors into the wellbore and to the correct position. (See FIGS. 4C and 4D). The conveyance device may utilize one or more mechanisms such as wireline cable, coiled tubing, coiled tubing with wireline conductor, drill pipe, tubing or casing.

A deployment device 33 can be incorporated into the bottom hole assembly to expand the bistable expandable tubular and connectors. (See FIGS. 4C and 4D). Deployment devices can be of numerous types such as an inflatable packer element, a mechanical packer element, an expandable swage, a piston apparatus, a mechanical actuator, an electrical solenoid, a plug type apparatus, e.g. a conically shaped device pulled or pushed through the tubing, a ball type apparatus or a rotary type expander as further discussed below.

An inflatable packer element is shown in FIGS. 5A and 5B and is a device with an inflatable bladder, element, or bellows incorporated into the bistable expandable tubular system bottom hole assembly. In the illustration of FIG. 5A, the inflatable packer element 25 is located inside the entire length, or a portion, of the initial collapsed state bistable tubular 24 and any bistable expandable connectors (not shown). Once the bistable expandable tubular system is at the correct deployment depth, the inflatable packer element 25 is expanded radially by pumping fluid into the device as shown in FIG. 5B. The inflation fluid can be pumped from the surface through tubing or drill pipe, a mechanical pump, or via a downhole electrical pump which is powered via wireline cable. As the

6

inflatable packer element 25 expands, it forces the bistable expandable tubular 24 to also expand radially. At a certain expansion diameter, the inflatable packer element causes the bistable cells in the tubular to reach a critical geometry where the bistable "snap" effect is initiated, and the bistable expandable tubular system expands to its final diameter. Finally the inflatable packer element 25 is deflated and removed from the deployed bistable expandable tubular 24.

A mechanical packer element is shown in FIGS. 6A and 6B and is a device with a deformable plastic element 26 that expands radially when compressed in the axial direction. The force to compress the element can be provided through a compression mechanism 27, such as a screw mechanism, cam, or a hydraulic piston. The mechanical packer element deploys the bistable expandable tubulars and connectors in the same way as the inflatable packer element. The deformable plastic element 26 applies an outward radial force to the inner circumference of the bistable expandable tubulars and connectors, allowing them in turn to expand from a contracted position (see FIG. 6A) to a final deployment diameter (see FIG. 6B).

An expandable swage is shown in FIGS. 7A-7D and comprises a series of fingers 28 that are arranged radially around a conical mandrel 30. FIGS. 7A and 7C show side and top views respectively. When the mandrel 30 is pushed or pulled through the fingers 28 they expand radially outwards, as illustrated in FIGS. 7B and 7D. An expandable swage is used in the same manner as a mechanical packer element to deploy a bistable expandable tubular and connector.

A piston type apparatus is shown in FIGS. 8A-8D and comprises a series of pistons 32 facing radially outwardly and used as a mechanism to expand the bistable expandable tubulars and connectors. When energized, the pistons 32 apply a radially directed force to deploy the bistable expandable tubular assembly as per the inflatable packer element. FIGS. 8A and 8C illustrate the pistons retracted while FIGS. 8B and 8D show the pistons extended. The piston type apparatus can be actuated hydraulically, mechanically or electrically.

A plug type actuator is illustrated in FIGS. 9A and 9B and comprises a plug 34 that is pushed or pulled through the bistable expandable tubulars 24 or connectors as shown in FIG. 9A. The plug is sized to expand the bistable cells past their critical point where they will snap to a final expanded diameter as shown in FIG. 9B.

A ball type actuator is shown in FIGS. 10A and 10B and operates when an oversized ball 36 is pumped through the middle of the bistable expandable tubulars 24 and connectors. To prevent fluid losses through the cell slots, an expandable elastomer based liner 38 is run inside the bistable expandable tubular system. The liner 38 acts as a seal and allows the ball 36 to be hydraulically pumped through the bistable tubular 24 and connectors. The effect of pumping the ball 36 through the bistable expandable tubulars 24 and connectors is to expand the cell geometry beyond the critical bistable point, allowing full expansion to take place as shown in FIG. 10B. Once the bistable expandable tubulars and connectors are expanded, the elastomer sleeve 38 and ball 36 are withdrawn.

Radial roller type actuators also can be used to expand the bistable tubular sections. FIG. 12 illustrates a motor driven expandable radial roller tool. The tool comprises one or more sets of arms 58 that are expanded to a set diameter by means of a mechanism and pivot. On the end of each set of arms is a roller 60. Centralizers 62 can be attached to the tool to locate it correctly inside the wellbore and the bistable tubular 24. A motor 64 provides the force to rotate the whole assembly, thus turning the roller(s) circumferentially inside the wellbore. The axis of the roller(s) is such as to allow the roller(s) to

rotate freely when brought into contact with the inner surface of the tubular. Each roller can be conically-shaped in section to increase the contact area of roller surface to the inner wall of the tubular. The rollers are initially retracted and the tool is run inside the collapsed bistable tubular. The tool is then rotated by the motor **64**, and rollers **60** are moved outwardly to contact the inner surface of the bistable tubular. Once in contact with the tubular, the rollers are pivoted outwardly a greater distance to apply an outwardly radial force to the bistable tubular. The outward movement of the rollers can be accomplished via centrifugal force or an appropriate actuator mechanism coupled between the motor **64** and the rollers **60**.

The final pivot position is adjusted to a point where the bistable tubular can be expanded to the final diameter. The tool is then longitudinally moved through the collapsed bistable tubular, while the motor continues to rotate the pivot arms and rollers. The rollers follow a shallow helical path **66** inside the bistable tubular, expanding the bistable cells in their path. Once the bistable tubular is deployed, the tool rotation is stopped and the roller retracted. The tool is then withdrawn from the bistable tubular by a conveyance device **68** that also can be used to insert the tool.

FIG. **13** illustrates a hydraulically driven radial roller deployment device. The tool comprises one or more rollers **60** that are brought into contact with the inner surface of the bistable tubular by means of a hydraulic piston **70**. The outward radial force applied by the rollers can be increased to a point where the bistable tubular expands to its final diameter. Centralizers **62** can be attached to the tool to locate it correctly inside the wellbore and bistable tubular **24**. The rollers **60** are initially retracted and the tool is run into the collapsed bistable tubular **24**. The rollers **60** are then deployed and push against the inside wall of the bistable tubular **24** to expand a portion of the tubular to its final diameter. The entire tool is then pushed or pulled longitudinally through the bistable tubular **24** expanding the entire length of bistable cells **23**. Once the bistable tubular **24** is deployed in its expanded state, the rollers **60** are retracted and the tool is withdrawn from the wellbore by the conveyance device **68** used to insert it. By altering the axis of the rollers **60**, the tool can be rotated via a motor as it travels longitudinally through the bistable tubular **24**.

Power to operate the deployment device can be drawn from one or a combination of sources such as: electrical power supplied either from the surface or stored in a battery arrangement along with the deployment device, hydraulic power provided by surface or downhole pumps, turbines or a fluid accumulator, and mechanical power supplied through an appropriate linkage actuated by movement applied at the surface or stored downhole such as in a spring mechanism.

The bistable expandable tubular system is designed so the internal diameter of the deployed tubular is expanded to maintain a maximum cross-sectional area along the expandable tubular. This feature enables mono-bore wells to be constructed and facilitates elimination of problems associated with traditional wellbore casing systems where the casing outside diameter must be stepped down many times, restricting access, in long wellbores.

The bistable expandable tubular system can be applied in numerous applications such as an expandable open hole liner (see FIG. **14**) where the bistable expandable tubular **24** is used to support an open hole formation by exerting an external radial force on the wellbore surface. As bistable tubular **24** is radially expanded in the direction of arrows **71**, the tubular moves into contact with the surface forming wellbore **29**. These radial forces help stabilize the formations and allow the drilling of wells with fewer conventional casing strings. The

open hole liner also can comprise a material, e.g. a wrapping **72**, that reduces the rate of fluid loss from the wellbore into the formations. The wrapping **72** can be made from a variety of materials including expandable metallic and/or elastomeric materials. By reducing fluid loss into the formations, the expense of drilling fluids can be reduced and the risk of losing circulation and/or borehole collapse can be minimized.

Liners also can be used within wellbore tubulars for purposes such as corrosion protection. One example of a corrosive environment is the environment that results when carbon dioxide is used to enhance oil recovery from a producing formation. Carbon dioxide (CO_2) readily reacts with any water (H_2O) that is present to form carbonic acid (H_2CO_3). Other acids can also be generated, especially if sulfur compounds are present. Tubulars used to inject the carbon dioxide as well as those used in producing wells are subject to greatly elevated corrosion rates. The present invention can be used for placing protective liners, a bistable tubular **24**, within an existing tubular (e.g. tubular **73** illustrated with dashed lines in FIG. **14**) to minimize the corrosive effects and to extend the useful life of the wellbore tubulars.

Another application involves use of the bistable tubular **24** illustrated in FIG. **14** as an expandable perforated liner. The open bistable cells in the bistable expandable tubular allow unrestricted flow from the formation while providing a structure to stabilize the borehole.

Still another application of the bistable tubular **24** is as an expandable sand screen where the bistable cells are sized to act as a sand control screen or an expandable screen element **74** can be affixed to the bistable expandable tubular as illustrated in FIG. **14A** in its collapsed state. The expandable screen element **74** can be formed as a wrapping around bistable tubular **24**. It has been found that the imposition of hoop stress forces onto the wall of a borehole will in itself help stabilize the formation and reduce or eliminate the influx of sand from the producing zones, even if no additional screen element is used.

Another application of the bistable tubular **24** is as a reinforced expandable liner where the bistable expandable tubular cell structure is reinforced with a cement or resin **75**, as illustrated in FIG. **14B**. The cement or resin **75** provides increased structural support or hydraulic isolation from the formation.

The bistable expandable tubular **24** also can be used as an expandable connection system to join traditional lengths of casing **76a** or **76b** of different diameters as illustrated in FIG. **14C**. The tubular **24** also can be used as a structural repair joint to provide increased strength for existing sections of casing.

Another application includes using the bistable expandable tubular **24** as an anchor within the wellbore from which other tools or casings can be attached, or as a "fishing" tool in which the bistable characteristics are utilized to retrieve items lost or stuck in a wellbore. The bistable expandable tubular **24** in its collapsed configuration is inserted into a lost item **77** and then expanded as indicated by arrows **78** in FIG. **14D**. In the expanded configuration the bistable tubular exerts radial forces that assist in retrieving the lost item. The bistable tubular also can be run into the well in its expanded configuration, placed over and collapsed in the direction of arrows **79** around lost item **77** in an attempt to attach and retrieve it as illustrated in FIG. **14E**. Once lost item **77** is gripped by bistable tubular **24**, it can be retrieved through wellbore **29**.

The above described bistable expandable tubulars can be made in a variety of manners such as: cutting appropriately shaped paths through the wall of a tubular pipe thereby creating an expandable bistable device in its collapsed state;

cutting patterns into a tubular pipe thereby creating an expandable bistable device in its expanded state and then compressing the device into its collapsed state; cutting appropriate paths through a sheet of material, rolling the material into a tubular shape and joining the ends to form an expandable bistable device in its collapsed state; or cutting patterns into a sheet of material, rolling the material into a tubular shape, joining the adjoining ends to form an expandable bistable device in its expanded state and then compressing the device into its collapsed state.

The materials of construction for the bistable expandable tubulars can include those typically used within the oil and gas industry such as carbon steel. They can also be made of specialty alloys (such as a monel, inconel, hastelloy or tungsten-based alloys) if the application requires.

The configurations shown for the bistable tubular **24** are illustrative of the operation of a basic bistable cell. Other configurations may be suitable, but the concept presented is also valid for these other geometries.

FIG. **15** illustrates an expandable tubing **80** formed of bi-stable cells **82**. The tubing **80** defines a thinned portion **84** (best seen in FIG. **15**) which may be in the form of a slot, as shown, a flattening, or other thinning of a portion of the tubing **80**. The thinned portion **84** extends generally longitudinally and may be linear, helical, or follow some other circuitous path. In one embodiment, the thinned portion extends from one end of the tubing to the other to provide a communication line path **84** for the tubing **80**. In such an embodiment, a communication line **86** may pass through the communication line path **84** along the tubing **80**. In this way, the communication line **86** stays within the general outside diameter of the tubing **80** or extends only slightly outside this diameter. Although the tubing is shown with one thinned portion **84**, it may include a plurality that are spaced about the circumference of the tubing **80**. The thinned portion **84** may be used to house a conduit (not shown) through which communication lines **86** pass or which is used for the transport of fluids or other materials, such as mixtures of fluids and solids.

As used herein, the term "communication line" refers to any type of communication line such as electric, hydraulic, fiber optic, combinations of these, and the like.

FIG. **15A** illustrates an exemplary thinned portion **84** designed to receive a device **88**. As with the cable **60** placement, device **88** is at least partially housed in the thinned portion of the tubing **80** so that the extent to which it extends beyond the outer diameter of the tubing **80** is lessened. Examples of certain alternative embodiments of devices **88** are electrical devices, measuring devices, meters, gauges, sensors. More specific examples comprise valves, sampling devices, a device used in intelligent or smart well completion, temperature sensors, pressure sensors, flow-control devices, flow rate measurement devices, oil/water/gas ratio measurement devices, scale detectors, equipment sensors (e.g., vibration sensors), sand detection sensors, water detection sensors, data recorders, viscosity sensors, density sensors, bubble point sensors, composition sensors, resistivity array devices and sensors, acoustic devices and sensors, other telemetry devices, near infrared sensors, gamma ray detectors, H₂S detectors, CO₂ detectors, downhole memory units, downhole controllers. Examples of measurements that the devices might make are flow rate, pressure, temperature, differential pressure, density, relative amounts of liquid, gas, and solids, water cut, oil-water ratio, and other measurements.

As shown in the figure, the device **88** may be exposed to fluid inside and outside of tubing **80** via openings formed by the cells **82**. Thus, the thinned portion **84** may bridge openings as well as linkages **21**, **22** of the cells **82**. Also note that

the communication line **86** and associated communication line path **84** may extend a portion of the length of the tubing **80** in certain alternative designs. For example, if a device **88** is placed intermediate the ends of the tubing **80**, the communication line passageway **84** may only need to extend from an end of the tubing to the position of the device **80**.

FIG. **16** illustrates an expandable tubing **80** formed of bi-stable cells **82** having thin struts **21** and thick struts **22**. At least one of the thick struts (labeled as **90**) is relatively wider than other struts of the tubing **80**. The wider strut **90** may be used for various purposes such as routing of communication lines, including cables, or devices, such as sensor arrays.

FIGS. **17A** and **17B** illustrate tubing **80** having a strut **90** that is relatively wider than the other thick struts **22**. A passageway **92** formed in the strut **90** facilitates placement of a communication line in the well and through the tubing **80** and may be used for other purposes. FIG. **17B** is a cross sectional view showing the passageway **92**. Passageway **92** is an alternative embodiment of a communication line path **84**. A passageway **94** may be configured to generally follow the curvature of a strut, e.g. one of the thick struts **22**, as further illustrated in FIGS. **17A** and **17B**.

FIG. **18** illustrates a thinned portion **84** having a dovetail design with a relatively narrower opening. The communication line **86** is formed so that it fits through the relatively narrow opening into the wider, lower portion, e.g. by inserting one side edge and then the other. Communication line **86** is held in place due to the dovetail design as is apparent from the figures. The width of the communication line **86** is greater than the width of the opening. Note that the communication line **86** may comprise a bundle of lines which may be of the same or different forms (e.g., a hydraulic, an electric, and a fiber optic line bundled together). Also, connectors for connecting adjacent tubings may incorporate a connection for the communication lines.

Note that the communication line passageway **84** may be used in conjunction with other types of expandable tubings, such as those of the expandable slotted liner type disclosed in U.S. Pat. No. 5,366,012, issued Nov. 22, 1994 to Lohbeck, the folded tubing types of U.S. Pat. No. 3,489,220, issued Jan. 13, 1970 to Kinley, U.S. Pat. No. 5,337,823, issued Aug. 16, 1994 to Nobileau, U.S. Pat. No. 3,203,451, issued Aug. 31, 1965 to Vincent.

The particular embodiments disclosed herein are illustrative only, as the invention may be modified and practiced in different but equivalent manners apparent to those skilled in the art having the benefit of the teachings herein. Furthermore, no limitations are intended to the details of construction or design herein shown, other than as described in the claims below. It is therefore evident that the particular embodiments disclosed above may be altered or modified and all such variations are considered within the scope and spirit of the invention. Accordingly, the protection sought herein is as set forth in the claims below.

What is claimed is:

- [1.** An apparatus for use in a wellbore, comprising:
 - an expandable bistable device configured for deployment proximate a wellbore wall, the expandable bistable device having a plurality of bistable cells arranged in a generally tubular shape, the plurality of bistable cells being stable in a collapsed configuration and in an expanded configuration,
 - wherein each cell comprises a first member and a second member, the first member and the second member each comprising a mid-point and two ends, and
 - further wherein the first member is more flexible than the second member.]

11

[2. The apparatus as recited in claim 2, wherein the first and second members are mechanically connected such that the second member hinders deformation of the first member.]

[3. The apparatus as recited in claim 1, wherein the first member has two stable positions, the first stable position being where the first member mid-point is adjacent to the second member mid-point, the second stable position being where the first member mid-point is displaced from the second member mid-point to form a gap between the first member mid-point and the second member mid-point.]

[4. The apparatus as recited in claim 1, wherein the second member has a greater thickness than the first member.]

[5. The apparatus as recited in claim 1, wherein the thickness ratio of the second member to the first member is greater than approximately 3:1.]

6. [The] An apparatus [as recited in claim 1,] for use in a wellbore, comprising:

an expandable bistable device configured for deployment proximate a wellbore wall, the expandable bistable device having a plurality of bistable cells arranged in a generally tubular shape, the plurality of bistable cells being stable in a collapsed configuration and in an expanded configuration,

wherein each cell comprises a first member and a second member, the first member and the second member each comprising a mid-point and two ends,

wherein the thickness ratio of the second member to the first member is greater than approximately 6:1[,] and further wherein the first member is more flexible than the second member.

[7. An apparatus for use in a wellbore, comprising: an expandable bistable device configured for deployment proximate a wellbore wall, the expandable bistable device having a plurality of bistable cells arranged in a generally tubular shape, the plurality of bistable cells being stable in a collapsed configuration and in an expanded configuration,

wherein the bistable device further comprises a wrapping attached to the outer surface of the bistable device.]

8. [A The] An apparatus [as recited in claim 7,] for use in a wellbore, comprising:

an expandable bistable device configured for deployment proximate a wellbore wall, the expandable bistable device having a plurality of bistable cells arranged in a generally tubular shape, the plurality of bistable cells being stable in a collapsed configuration and in an expanded configuration,

wherein the bistable device further comprises a wrapping attached to the other surface of the bistable device, and wherein the wrapping comprises an expandable screen.

[9. The apparatus as recited in claim 7, wherein the wrapping comprises a deformable material.]

[10. The apparatus as recited in claim 9, wherein the deformable material comprises an elastomer.]

11. [The] An apparatus [as recited in claim 10, wherein the] for use in a wellbore, comprising:

an expandable bistable device configured for deployment proximate a wellbore wall, the expandable bistable device having a plurality of bistable cells arranged in a generally tubular shape, the plurality of bistable cells being stable in a collapsed configuration and in an expanded configuration,

wherein the bistable device further comprises a wrapping attached to the outer surface of the bistable device, and

12

wherein the wrapping comprises a deformable material that comprises an elastomer [is] selected to be resistant to crude oils, brines, and acids encountered in oil and gas wells.

[12. An apparatus for use in a wellbore, comprising: an expandable bistable device configured for deployment proximate a wellbore wall, the expandable bistable device having a plurality of bistable cells arranged in a generally tubular shape, the plurality of bistable cells being stable in a collapsed configuration and in an expanded configuration, wherein the bistable device in its second generally tubular configuration comprises a plurality of diameters.]

[13. A method of stabilizing an uncased section of a wellbore in an underground formation, comprising: providing an expandable bistable device having a generally tubular shape that comprises a plurality of bistable cells; placing the bistable device at a position in the wellbore while in a first stable state; radially expanding the bistable device to a second stable state having a generally tubular configuration without substantially reducing axial length; and attaching a wrapping to the outer surface of the bistable device.]

14. [The] A method [as recited in claim 13,] of stabilizing an uncased section of a wellbore in an underground formation, comprising:

providing an expandable bistable device having a generally tubular shape that comprises a plurality of bistable cells;

placing the bistable device at a position in the wellbore while in a first stable state;

radially expanding the bistable device to a second stable state having a generally tubular configuration without substantially reducing axial length; and

attaching a wrapping to the outer surface of the bistable device, wherein [attaching comprises attaching] the wrapping comprises an expandable screen.

[15. [The] A method [as recited in claim 13, further comprising] of stabilizing an uncased section of a wellbore in an underground formation, comprising:

providing an expandable bistable device having a generally tubular shape that comprises a plurality of bistable cells;

placing the bistable device at a position in the wellbore while in a first stable state;

radially expanding the bistable device to a second stable state having a generally tubular configuration without substantially reducing axial length; and

applying a deformable material that comprises an elastomer selected to be resistant to crude oils, brines, and acids encountered in oil and gas wells to the outer surface of the bistable device.

[16. The method as recited in claim 15, wherein applying comprises applying an elastomeric material.]

[17. The method as recited in claim 13, wherein radially expanding comprises expanding the bistable device to a plurality of final diameters.]

[18. A method for installing liners within a tubular located in a wellbore, comprising:

forming an expandable bistable device with a plurality of bistable cells, the expandable bistable device having a generally tubular shape;

surrounding the expandable bistable device with an expandable liner element attached to an outer surface of the bistable device;

13

placing the expandable bistable device at a position within a tubular while in a first stable state; and
 expanding the expandable bistable device into a second stable state to hold the liner element against an inner diameter of the tubular.]

[19. The method as recited in claim 18, further comprising locating multiple bistable devices in the wellbore such that the ends of the adjacent bistable devices overlap and form a continuation of the liner element against the inner diameter of the tubular.]

[20. The method as recited in claim 18, further comprising creating each bistable cell with a thin strut connected to a thick strut.]

21. A method for facilitating use of a wellbore, comprising: inhibiting sand influx into a wellbore, wherein inhibiting comprises:

placing a bistable device at a desired position in a wellbore; and

expanding the bistable device at least partially through a nonstable range towards a stable state until the bistable device is able to exert hoop stress forces against the wellbore.

14

22. The method as recited in claim 21, further comprising attaching a wrapping to an outer surface of the bistable member.

23. The method as recited in claim 22, wherein attaching comprises attaching an expandable screen.

24. A system for facilitating communication along a wellbore, comprising:

an expandable tubing formed of a plurality of bi-stable cells, the expandable tubing having a communication line passageway,

wherein the communication line passageway is defined by a thinned portion along the expandable tubing.

25. A method of routing a communication line in a well, comprising:

deploying an expandable tubing in a well, wherein deploying comprises running an expandable tubing formed of bistable cells into a well;

routing at least a portion of a communication line adjacent at least a portion of the expandable tubing;

expanding the expandable tubing; and

forming the communication line along a thick strut formed between a plurality of bistable cells.

* * * * *