

US00RE45104E

(19) **United States**  
(12) **Reissued Patent**  
**Jaggi et al.**

(10) **Patent Number:** **US RE45,104 E**  
(45) **Date of Reissued Patent:** **\*Sep. 2, 2014**

(54) **DISTRIBUTED TERMINAL OPTICAL TRANSMISSION SYSTEM**

(56) **References Cited**

(71) Applicant: **Pivotal Decisions LLC**, Las Vegas, NV (US)

U.S. PATENT DOCUMENTS  
4,109,111 A 8/1978 Cook  
4,229,831 A 10/1980 Lacher

(72) Inventors: **Pawan P. Jaggi**, Plano, TX (US);  
**Marvin R. Young**, Richardson, TX (US); **William David Bragg**, Redmond, WA (US)

(Continued)

FOREIGN PATENT DOCUMENTS

(73) Assignee: **Pivotal Decisions LLC**, Las Vegas, NV (US)

JP 01115230 5/1989  
JP 02238736 9/1990  
WO WO 03/084082 10/2003

OTHER PUBLICATIONS

(\*) Notice: This patent is subject to a terminal disclaimer.

The Cook Report on the Internet, "Netera Offers CWDM Gig E Backbone Supernet to Bring Fiber to Entire Province Focus on Alberta in Assessing Canadian Development in Current Economic Downturn", Jun. 2001, pp. 1-31.

(21) Appl. No.: **13/739,357**

(Continued)

(22) Filed: **Jan. 11, 2013**

*Primary Examiner* — Leslie Pascal

(74) *Attorney, Agent, or Firm* — Christensen O'Connor Johnson Kindness PLLC

**Related U.S. Patent Documents**

Reissue of:

(64) Patent No.: **7,505,687**  
Issued: **Mar. 17, 2009**  
Appl. No.: **10/402,840**  
Filed: **Mar. 27, 2003**

(57) **ABSTRACT**

The invention facilitates optical signals generated from customer premise equipment (CPE) at the edges of the metro domain networks. The CPEs are connected to extension terminals that transform the optical signal originating at the CPE into a suitable format for long haul transmission. The optical signal then propagates to a primary terminal where the signal is multiplexed with other optical signals from other extension terminals. The multiplexed signals are then transmitted over LH or ULH network to a second primary terminal where the signal is then demultiplexed from other optical signals and transmitted to the proper extension terminal. At the extension terminal, the demultiplexed optical signal is transformed from its LH format back into a format suitable for interconnection to a CPE. Using this architecture, the signal under goes optical-to-electrical conversion only at the extension terminals or end points. These end points can be located in lessee's facility. The only equipment located in lessor's facility is the primary terminal containing line amplifiers and add/drop nodes.

U.S. Applications:

(63) Continuation of application No. 13/050,755, filed on Mar. 17, 2011, now Pat. No. Re. 44,015, which is an application for the reissue of Pat. No. 7,505,687.

(60) Provisional application No. 60/368,545, filed on Mar. 29, 2002.

(51) **Int. Cl.**  
**H04J 14/02** (2006.01)

(52) **U.S. Cl.**  
USPC ..... **398/66; 398/83**

(58) **Field of Classification Search**  
USPC ..... **398/66, 82-83**  
See application file for complete search history.

**20 Claims, 13 Drawing Sheets**

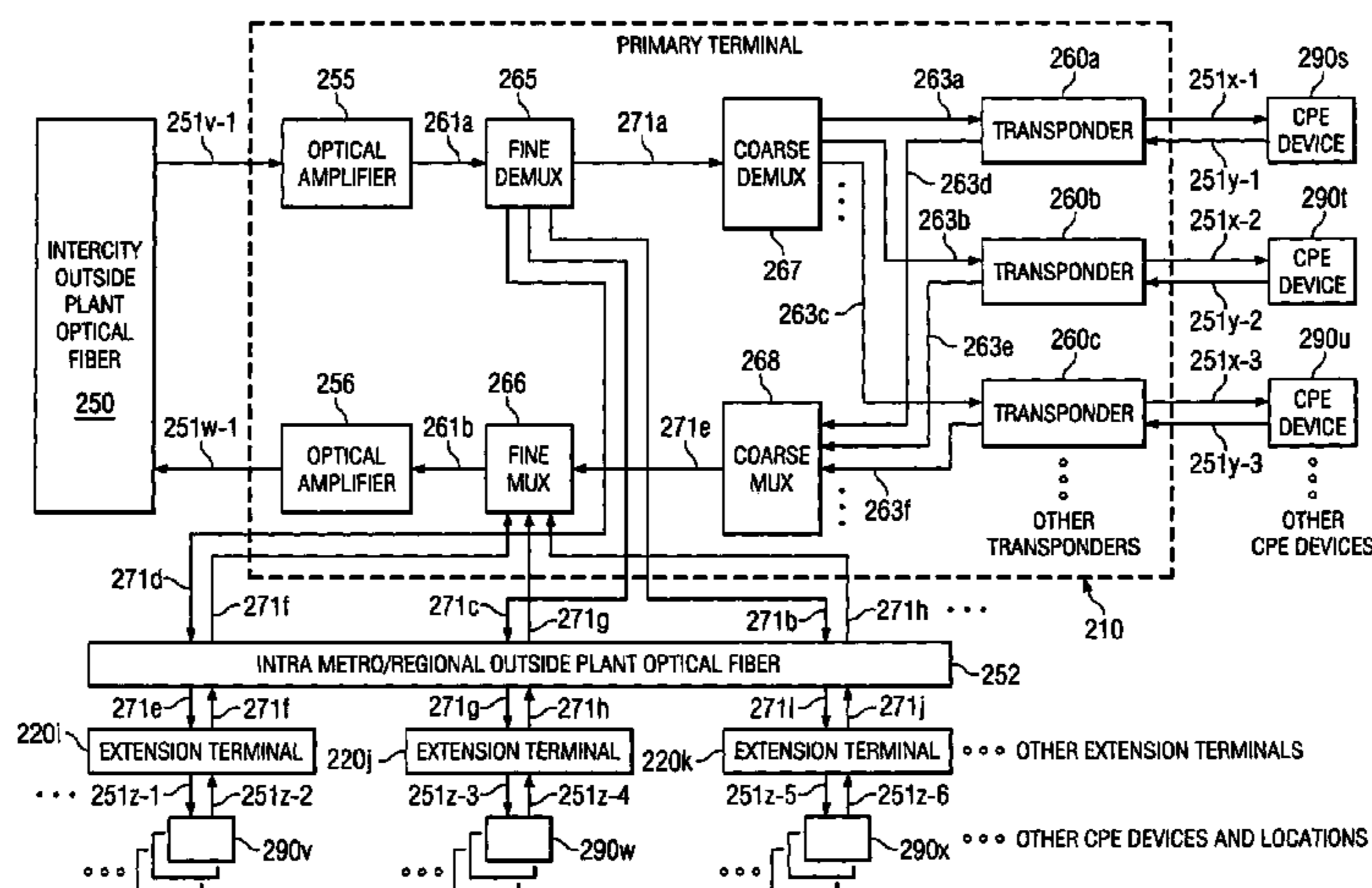

(56)

References Cited

U.S. PATENT DOCUMENTS

4,301,534 A 11/1981 Genter  
 4,355,384 A 10/1982 Genter et al.  
 4,535,459 A 8/1985 Hogge, Jr.  
 4,636,859 A 1/1987 Vernhet et al.  
 4,710,022 A 12/1987 Soeda et al.  
 5,224,183 A 6/1993 Dugan  
 5,225,922 A 7/1993 Chraplyvy et al.  
 5,267,071 A 11/1993 Little et al.  
 5,299,048 A 3/1994 Suyama  
 5,321,541 A 6/1994 Cohen  
 5,455,703 A 10/1995 Duncan et al.  
 5,559,625 A 9/1996 Smith et al.  
 5,613,210 A 3/1997 Van Driel et al.  
 5,726,784 A 3/1998 Alexander et al.  
 5,737,118 A 4/1998 Sugaya et al.  
 5,778,116 A 7/1998 Tomich  
 5,790,285 A 8/1998 Mock  
 5,812,290 A 9/1998 Maeno et al.  
 5,877,881 A 3/1999 Miyauchi et al.  
 5,903,613 A 5/1999 Ishida  
 5,914,794 A 6/1999 Fee  
 5,914,799 A 6/1999 Tan  
 5,936,753 A 8/1999 Ishikawa  
 5,940,209 A 8/1999 Nguyen  
 5,963,350 A 10/1999 Hill  
 5,995,694 A 11/1999 Akasaka et al.  
 6,005,702 A 12/1999 Suzuki et al.  
 6,021,245 A 2/2000 Berger et al.  
 6,038,062 A 3/2000 Kosaka  
 6,075,634 A 6/2000 Casper et al.  
 6,078,414 A 6/2000 Iwano  
 6,081,359 A 6/2000 Takehana et al.  
 6,081,360 A 6/2000 Ishikawa et al.  
 6,084,694 A 7/2000 Milton et al.  
 6,088,152 A 7/2000 Berger et al.  
 6,108,074 A 8/2000 Bloom  
 6,122,095 A 9/2000 Fatehi  
 6,151,334 A 11/2000 Kim et al.  
 6,157,477 A 12/2000 Robinson  
 6,160,614 A 12/2000 Unno  
 6,163,392 A 12/2000 Condict et al.  
 6,163,636 A 12/2000 Stentz et al.  
 6,173,094 B1 1/2001 Bowerman et al.  
 6,177,985 B1 1/2001 Bloom  
 6,198,559 B1 3/2001 Gehlot  
 6,229,599 B1 5/2001 Galtarossa  
 6,236,481 B1 5/2001 Laor  
 6,236,499 B1 5/2001 Berg et al.  
 6,246,510 B1 6/2001 BuAbbud et al.  
 6,259,553 B1 7/2001 Kinoshita  
 6,259,554 B1 7/2001 Shigematsu et al.  
 6,259,693 B1 7/2001 Ganmukhi et al.  
 6,259,845 B1 7/2001 Sardesai  
 6,272,185 B1 8/2001 Brown  
 6,275,315 B1 8/2001 Park et al.  
 6,282,334 B1 8/2001 Hodgson et al.  
 6,288,811 B1 9/2001 Jiang et al.  
 6,288,813 B1 9/2001 Kirkpatrick et al.  
 6,307,656 B2 10/2001 Terahara  
 6,307,986 B1 10/2001 Duerksen et al.  
 6,317,231 B1 11/2001 Al-Salameh et al.  
 6,317,255 B1 11/2001 Fatehi et al.  
 6,323,950 B1 11/2001 Kim et al.

6,327,060 B1 12/2001 Otani et al.  
 6,327,062 B1 12/2001 King et al.  
 6,339,663 B1 1/2002 Leng et al.  
 6,341,186 B1 1/2002 Singh et al.  
 6,356,384 B1 3/2002 Islam  
 6,359,729 B1 3/2002 Amoruso  
 6,388,801 B1 5/2002 Sugaya et al.  
 6,396,853 B1 5/2002 Humphrey et al.  
 6,480,326 B2 11/2002 Papernyi et al.  
 6,493,117 B1 12/2002 Milton et al.  
 6,515,779 B2 2/2003 Fee  
 6,519,082 B2 2/2003 Ghera et al.  
 6,546,166 B1 4/2003 Liu et al.  
 6,563,985 B2 5/2003 Yin et al.  
 6,574,037 B2 6/2003 Islam et al.  
 6,587,470 B1 7/2003 Elliot et al.  
 6,690,848 B2 2/2004 Graves et al.  
 6,694,100 B1 2/2004 Fatehi et al.  
 6,744,958 B2 6/2004 Inagaki et al.  
 6,744,988 B2 6/2004 Leclerc et al.  
 6,807,232 B2 10/2004 Nicholson et al.  
 6,822,943 B1 11/2004 Mantin  
 6,826,201 B2 11/2004 Hind  
 6,868,201 B1 3/2005 Johnson et al.  
 6,944,163 B2 9/2005 Botorff et al.  
 6,950,448 B2 9/2005 Tornetta et al.  
 7,046,695 B2 5/2006 Silvers  
 7,054,559 B1 5/2006 Le et al.  
 7,139,277 B2 11/2006 Ofek et al.  
 7,164,861 B2 1/2007 Takachio et al.  
 7,170,906 B2 1/2007 Ofek et al.  
 7,254,333 B2 8/2007 Shimizu  
 7,308,197 B1 12/2007 Zhong et al.  
 7,502,562 B2 3/2009 Jaggi et al.  
 7,505,687 B2 3/2009 Jaggi et al.  
 7,796,886 B2 9/2010 Jaggi et al.  
 RE43,403 E 5/2012 Jaggi et al.  
 RE44,015 E \* 2/2013 Jaggi et al. .... 398/66  
 2001/0005271 A1 6/2001 Leclerc et al.  
 2001/0007605 A1 7/2001 Inagaki et al.  
 2001/0009468 A1 7/2001 Fee  
 2001/0014104 A1 8/2001 Botorff et al.  
 2001/0017722 A1 8/2001 Takachio et al.  
 2001/0048799 A1 12/2001 King et al.  
 2002/0008913 A1 1/2002 Yin et al.  
 2002/0012152 A1 1/2002 Agazzi et al.  
 2002/0015220 A1 2/2002 Papernyl et al.  
 2002/0034197 A1 3/2002 Tornetta et al.  
 2002/0044317 A1 4/2002 Gentner et al.  
 2002/0044324 A1 4/2002 Hoshida et al.  
 2002/0048287 A1 4/2002 Silvers  
 2002/0051468 A1 5/2002 Ofek et al.  
 2002/0063948 A1 5/2002 Islam et al.  
 2002/0064181 A1 5/2002 Ofek et al.  
 2002/0075903 A1 6/2002 Hind  
 2002/0080809 A1 6/2002 Nicholson et al.  
 2002/0171897 A1 11/2002 Cho et al.  
 2003/0002776 A1 1/2003 Graves et al.  
 2003/0067655 A1 4/2003 Pedersen et al.  
 2006/0114939 A1 6/2006 Singh

OTHER PUBLICATIONS

International Patent Application No. PCT/US2003/09761: International Search Report dated Nov. 5, 2003, 3 pages.

\* cited by examiner

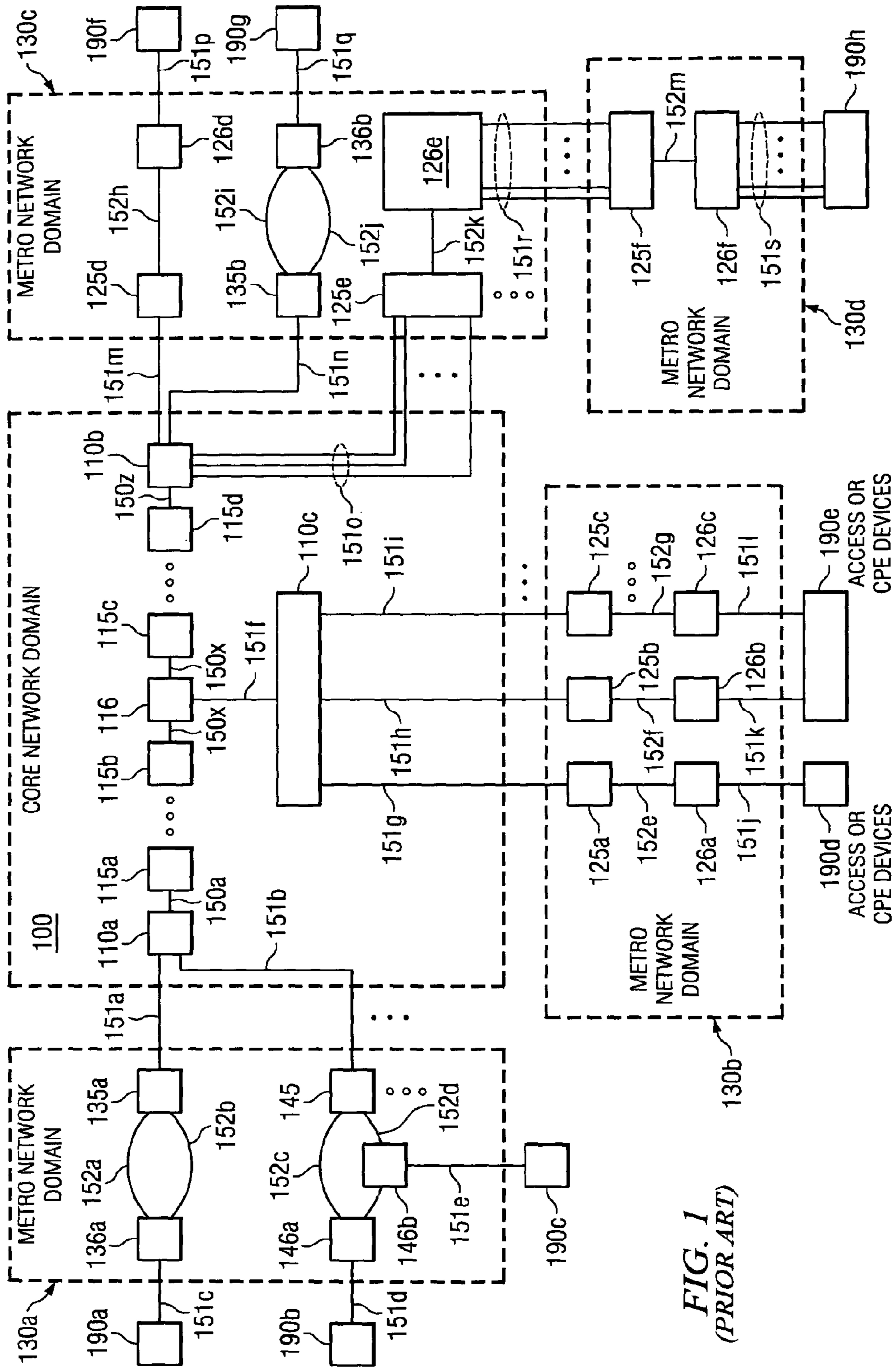

FIG. 1  
(PRIOR ART)

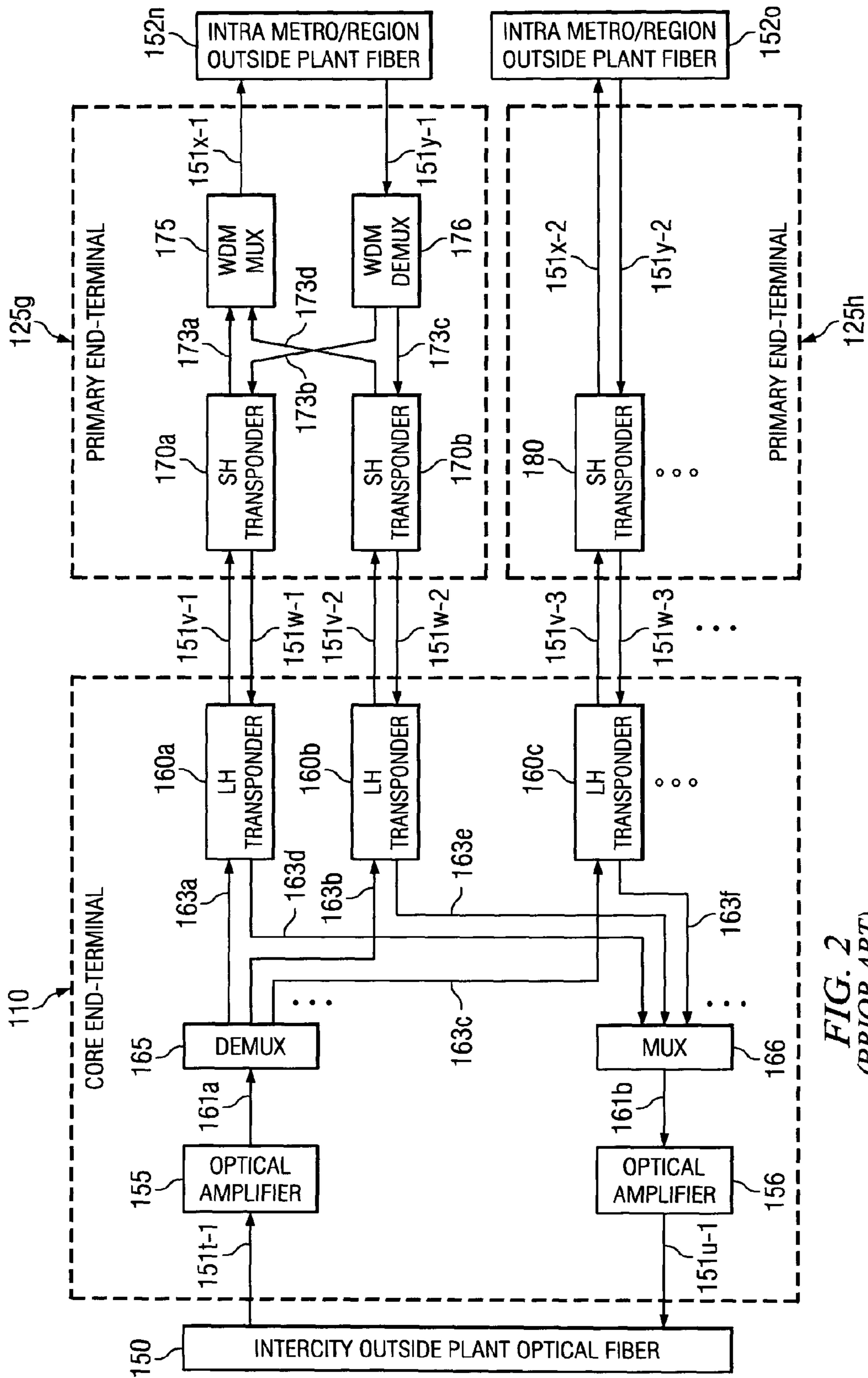
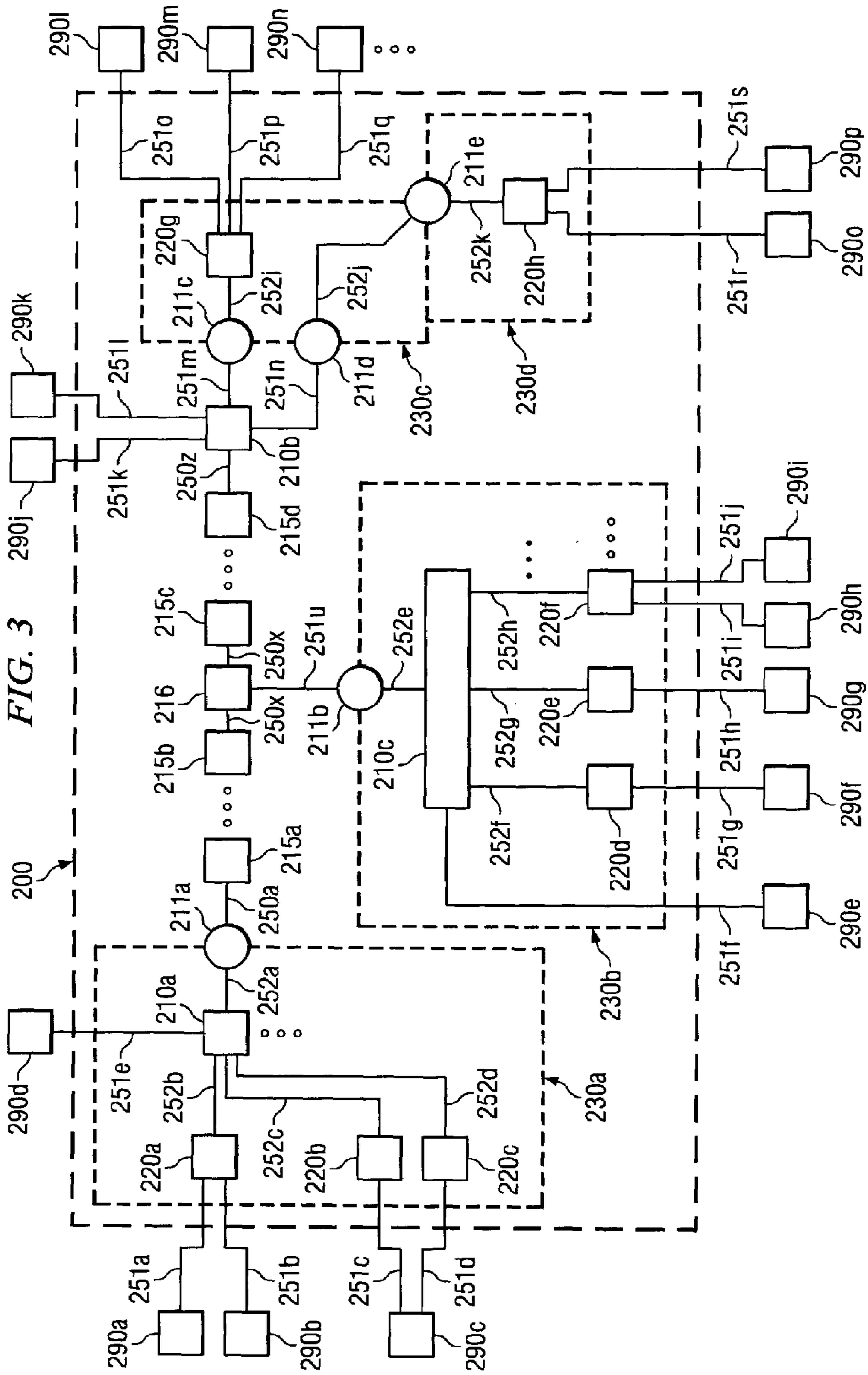
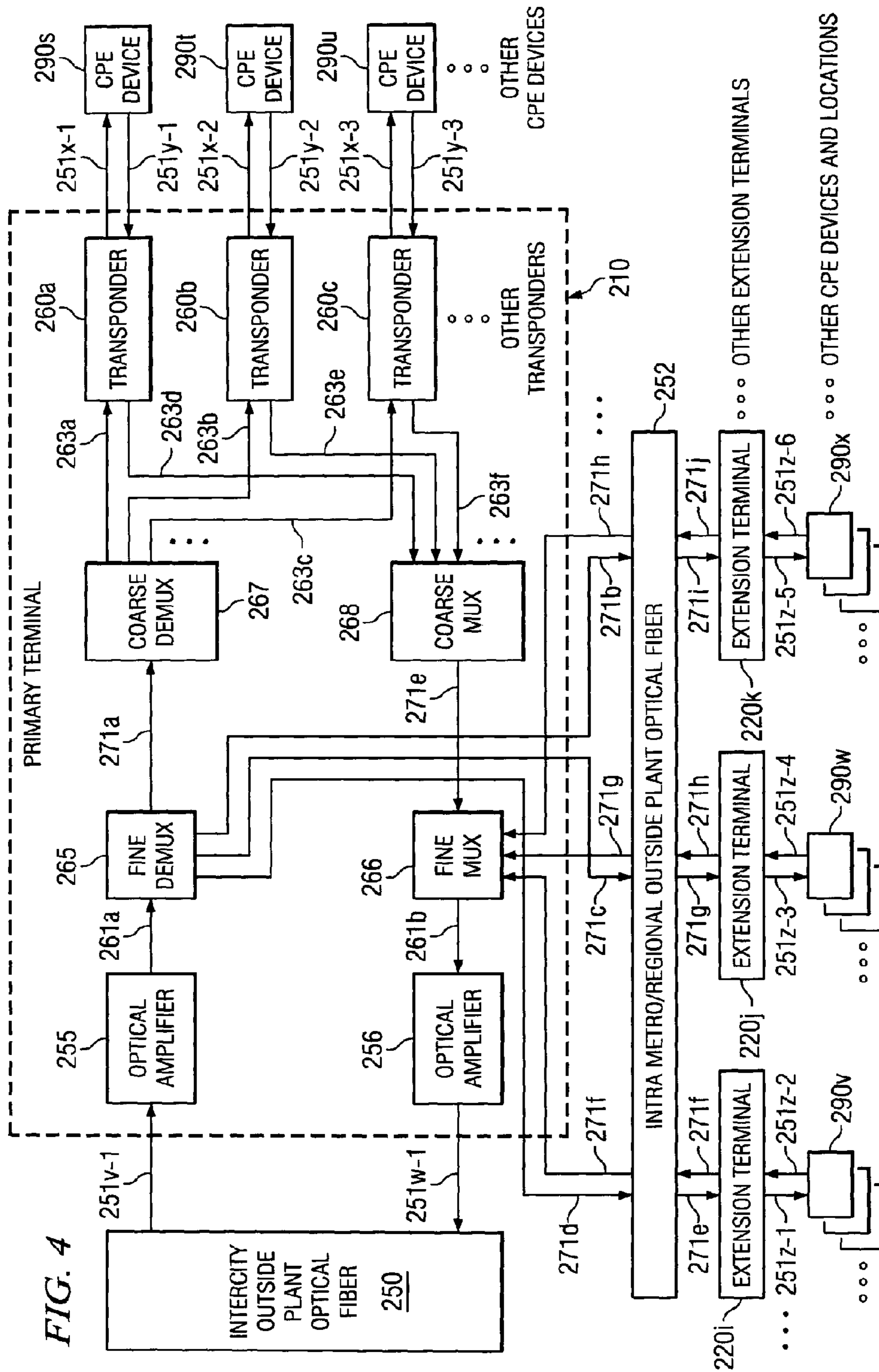
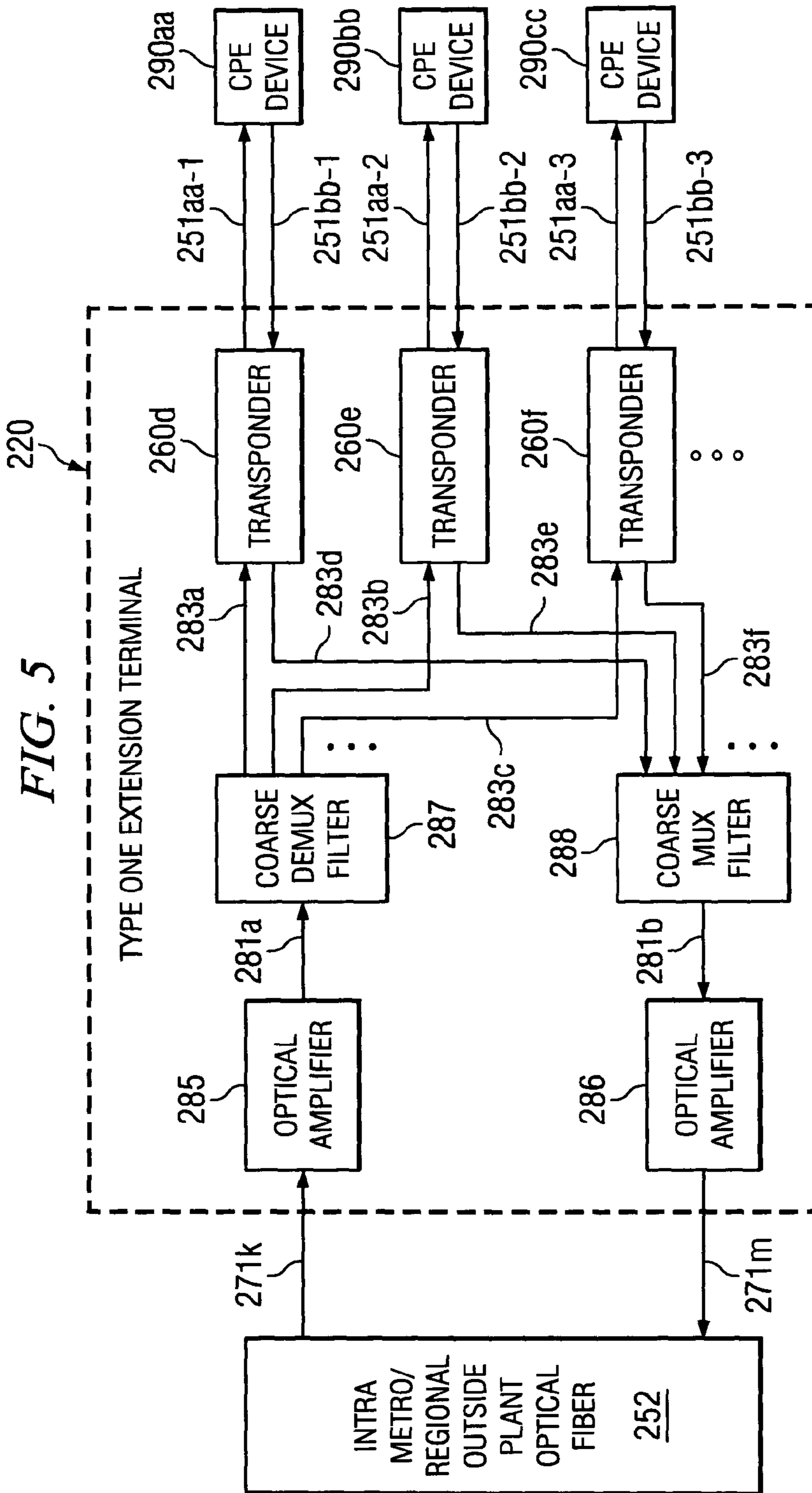

FIG. 2  
(PRIOR ART)







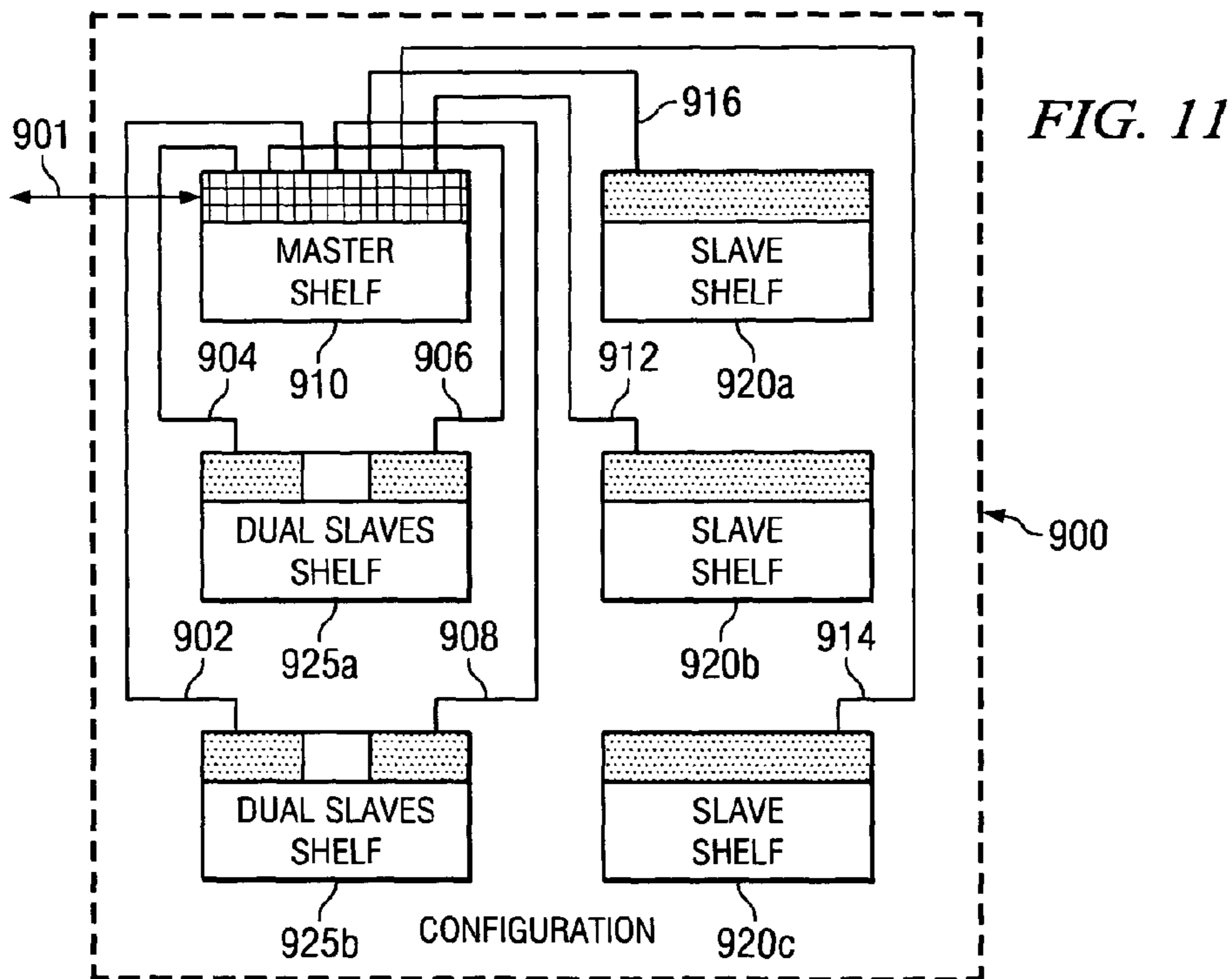
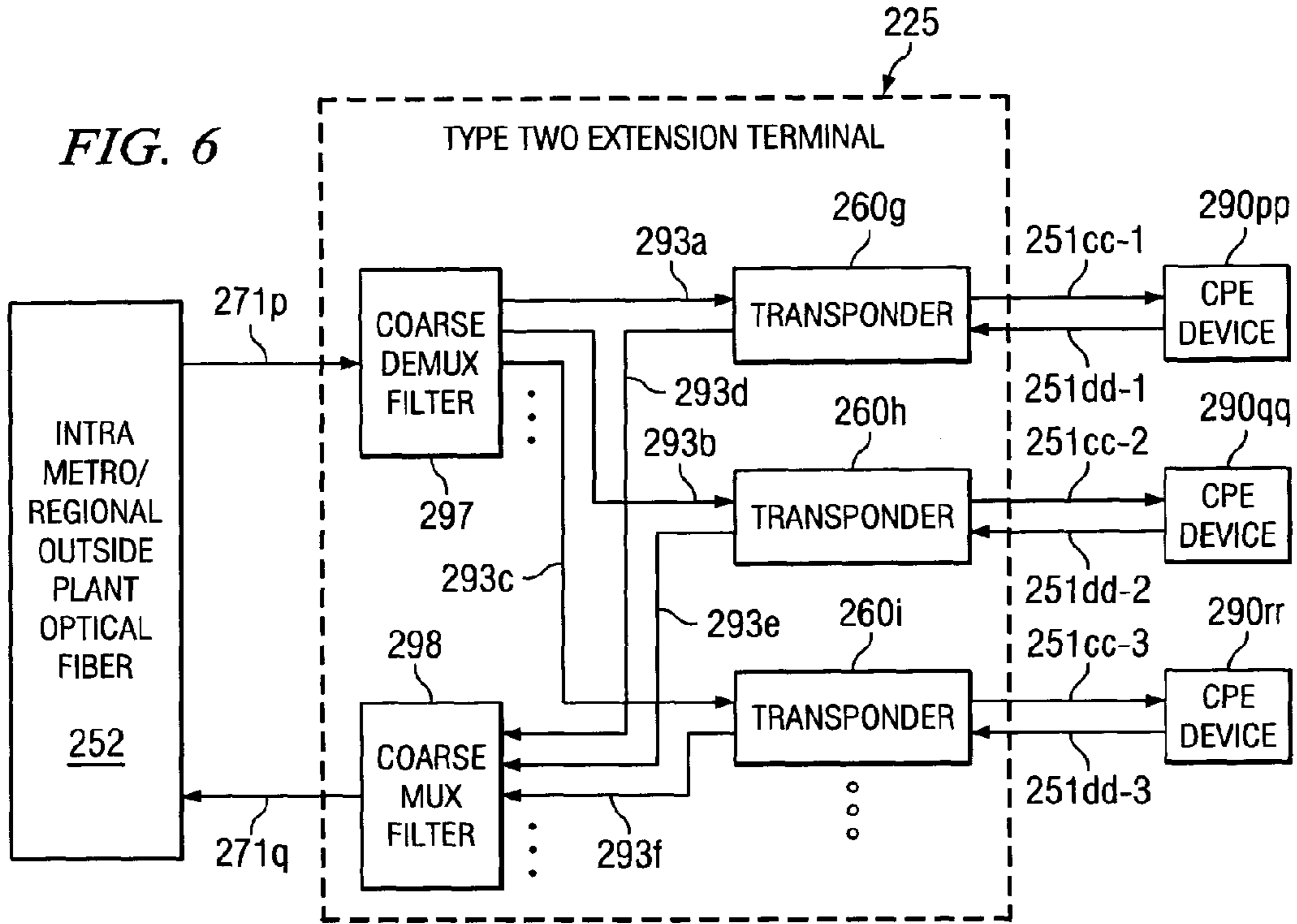



FIG. 7

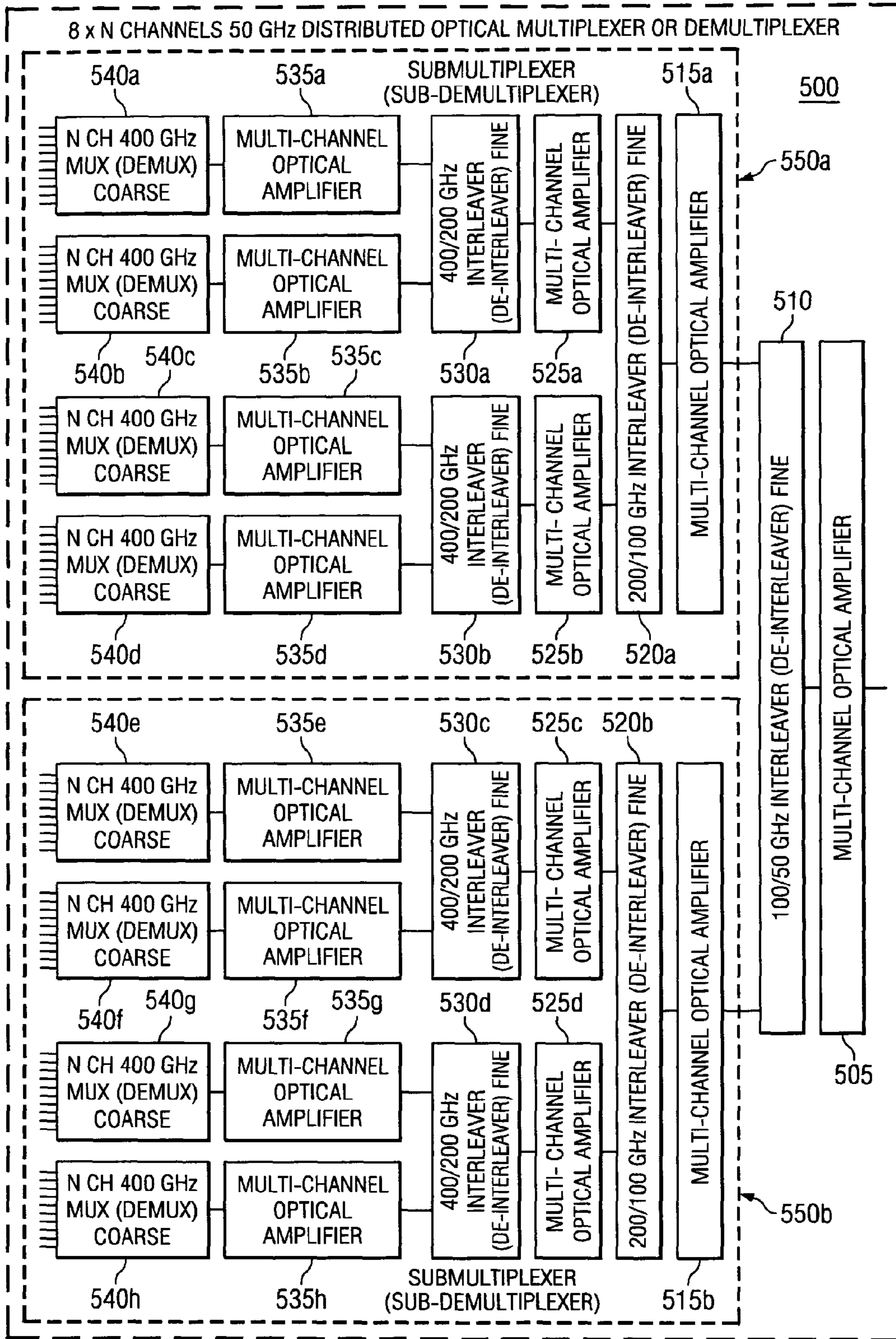

FIG. 8

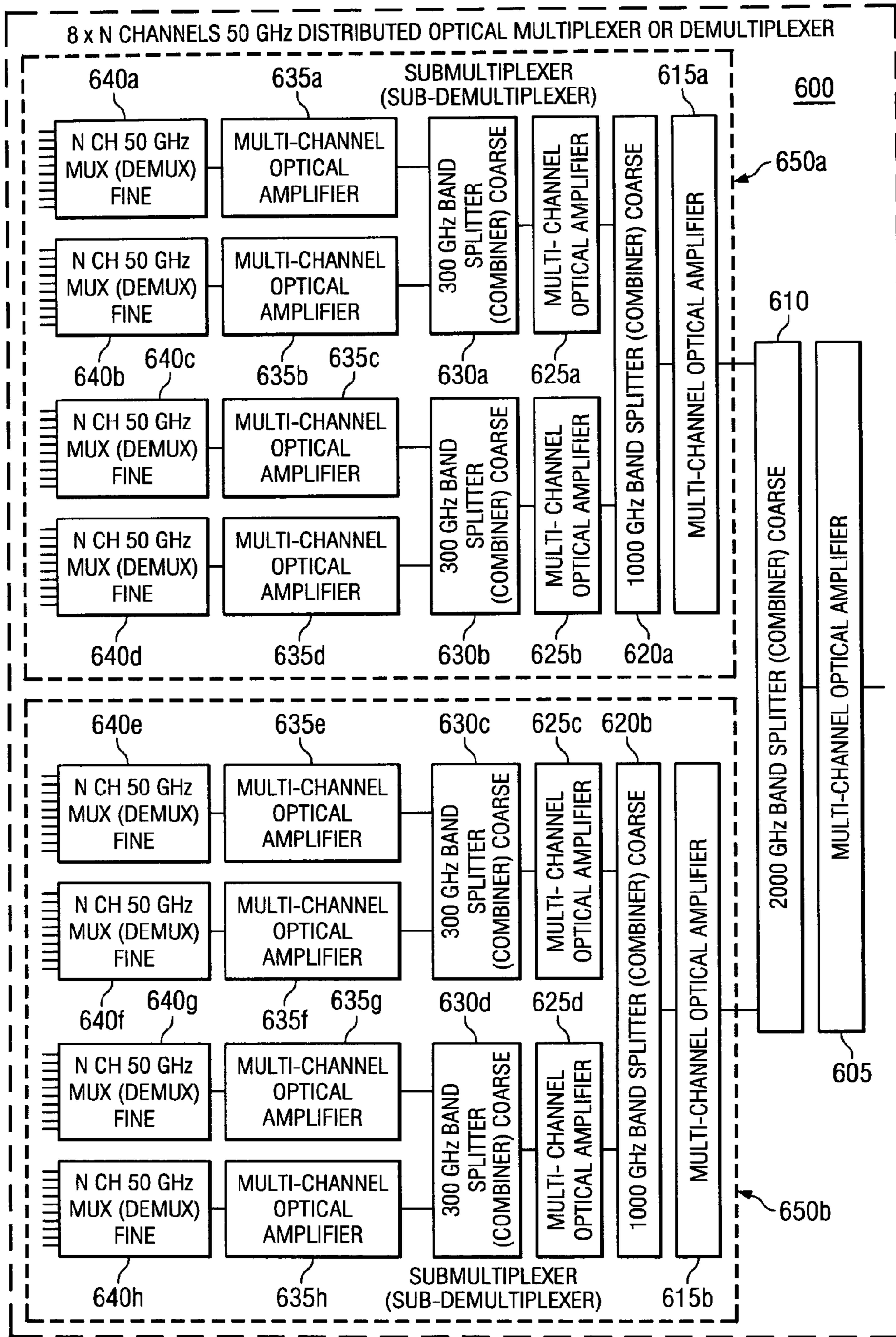
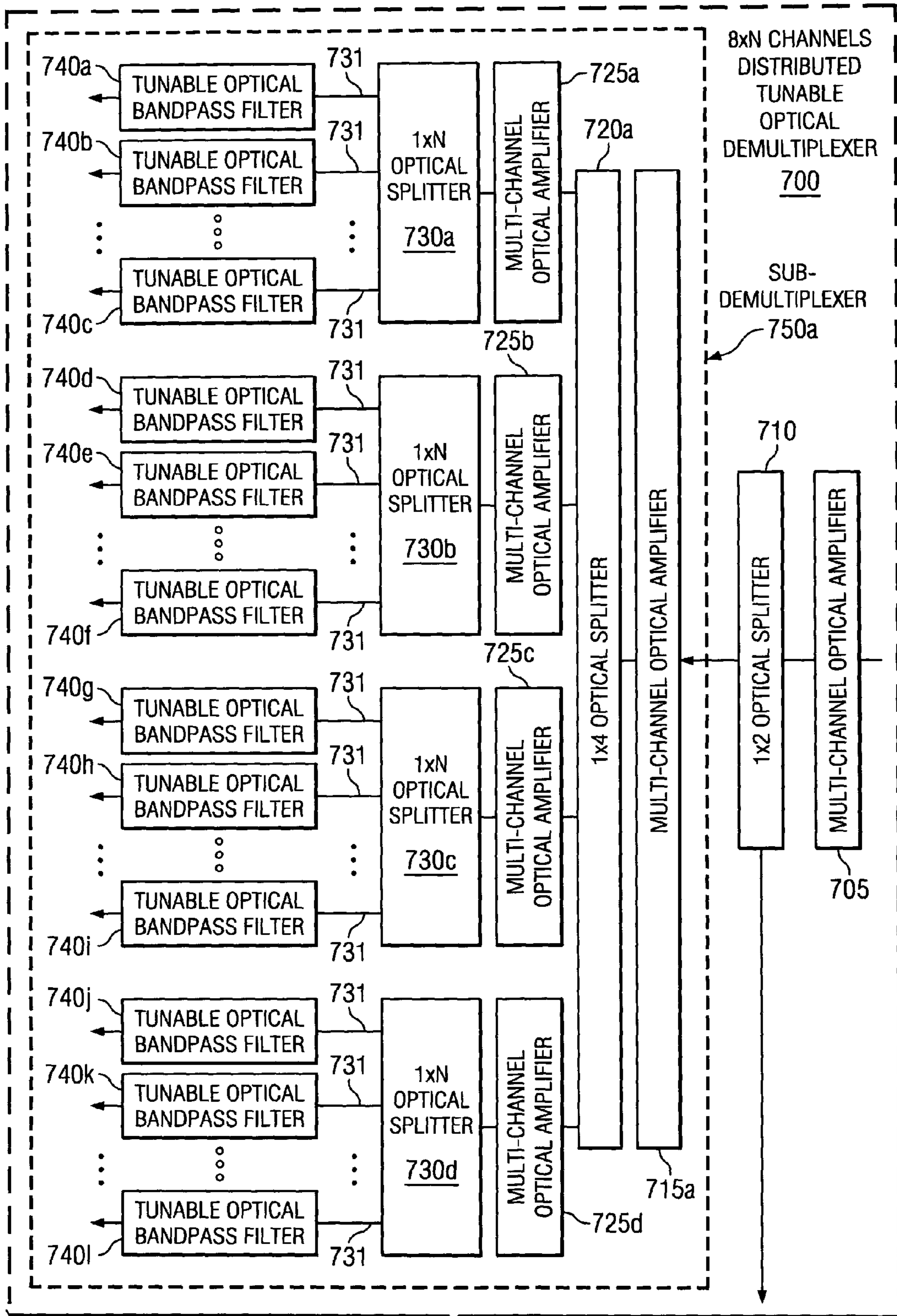

FIG. 9a



TO FIG. 9b

FIG. 9b

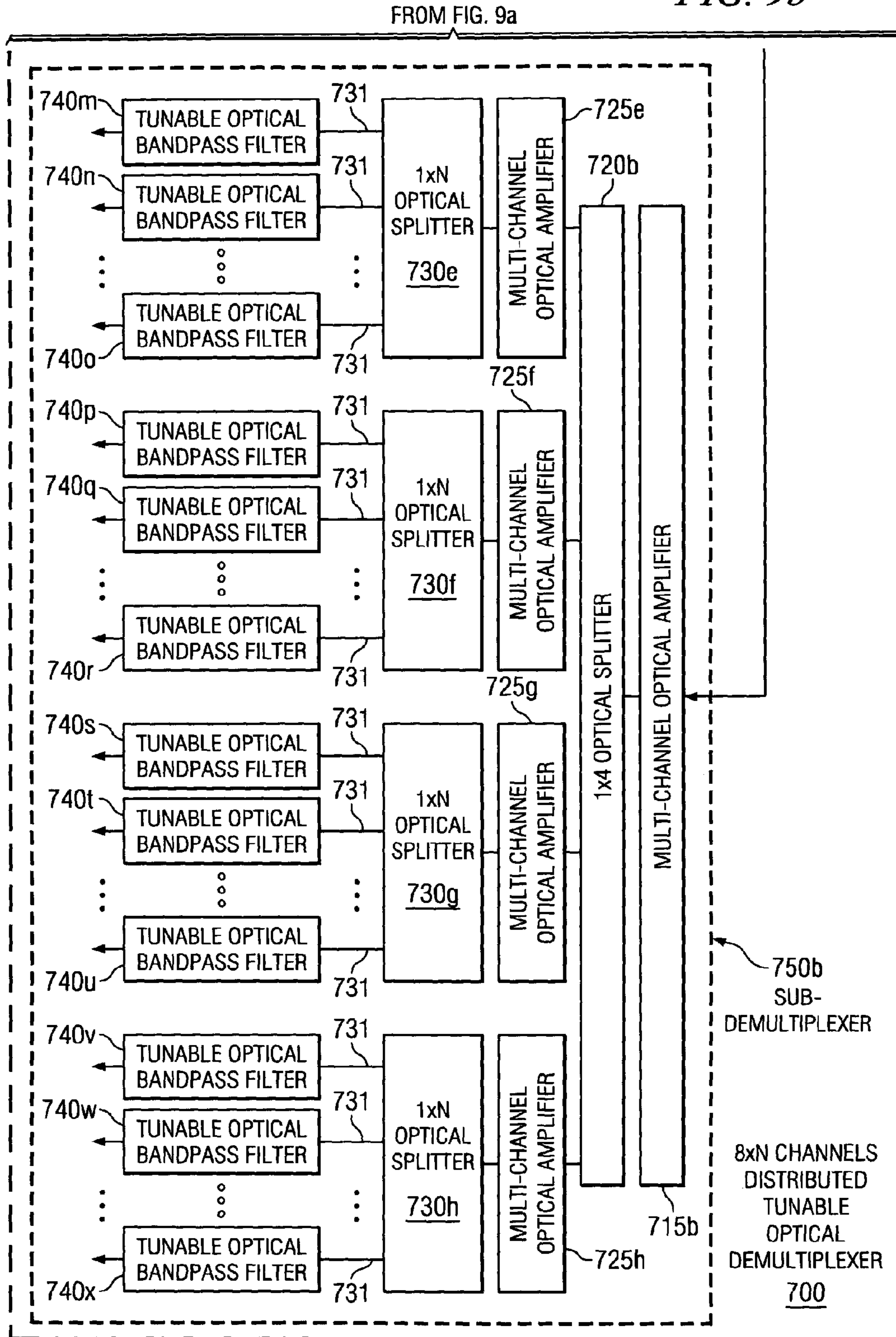
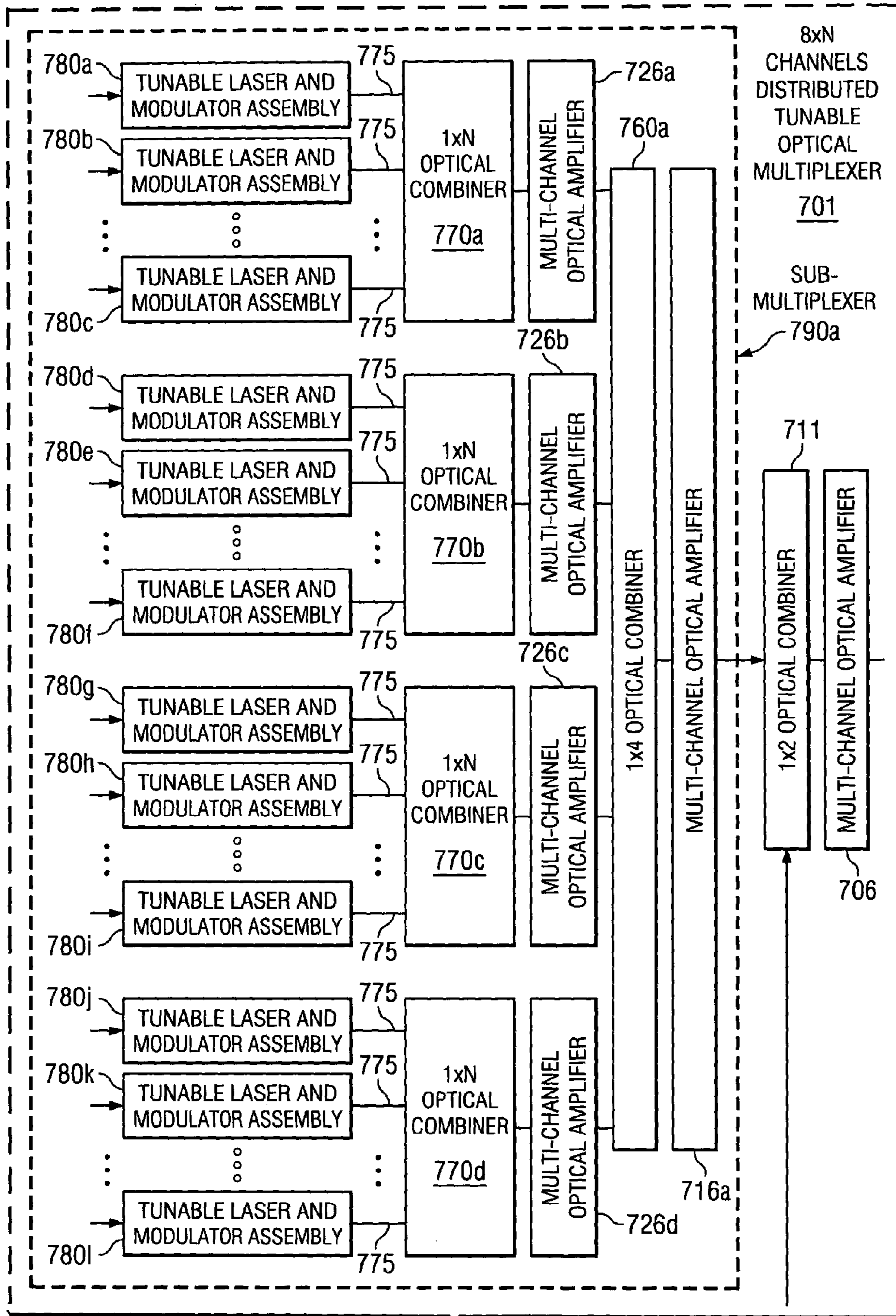

FIG. 10a



TO FIG. 10b

FIG. 10b

FROM FIG. 10a

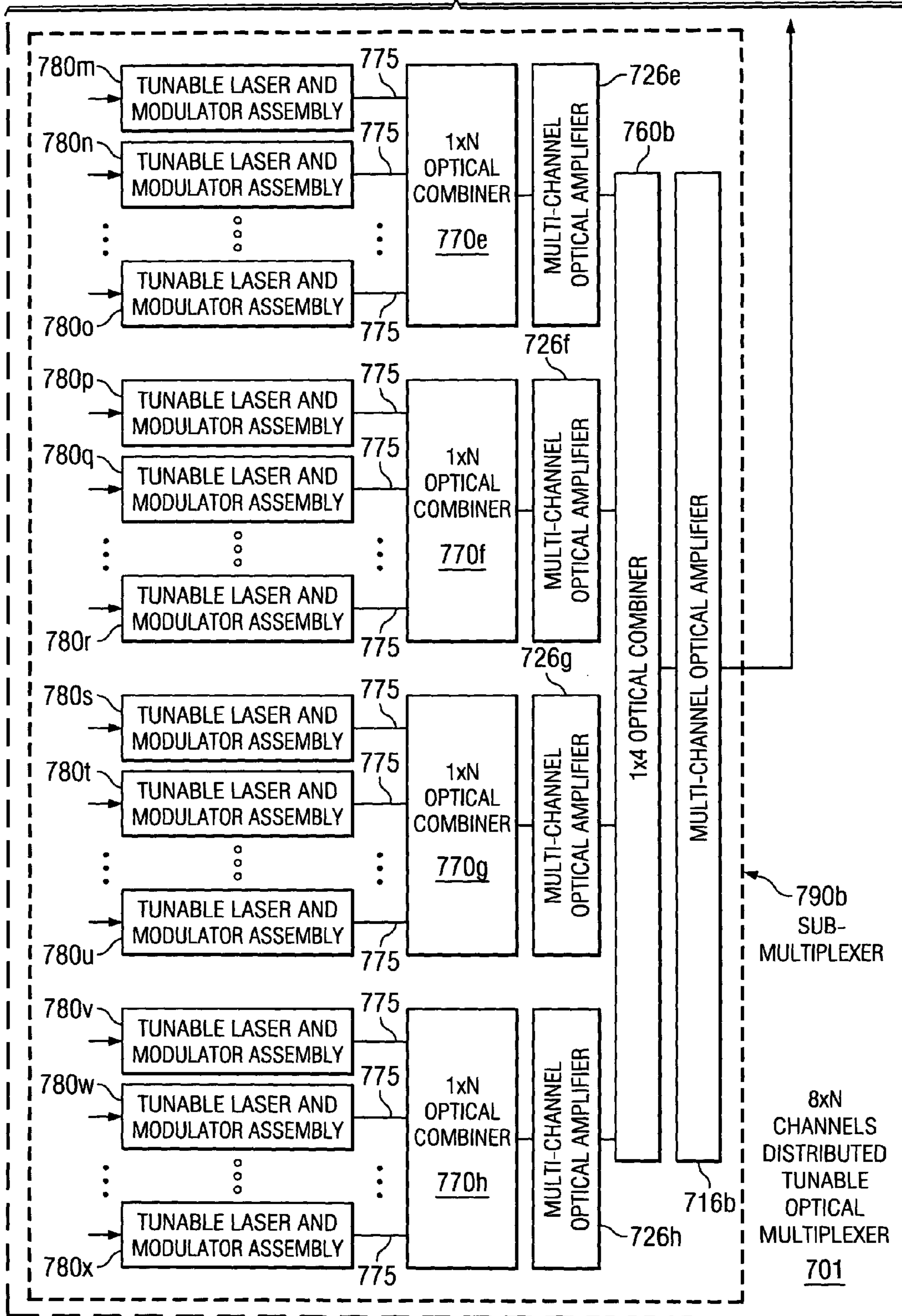

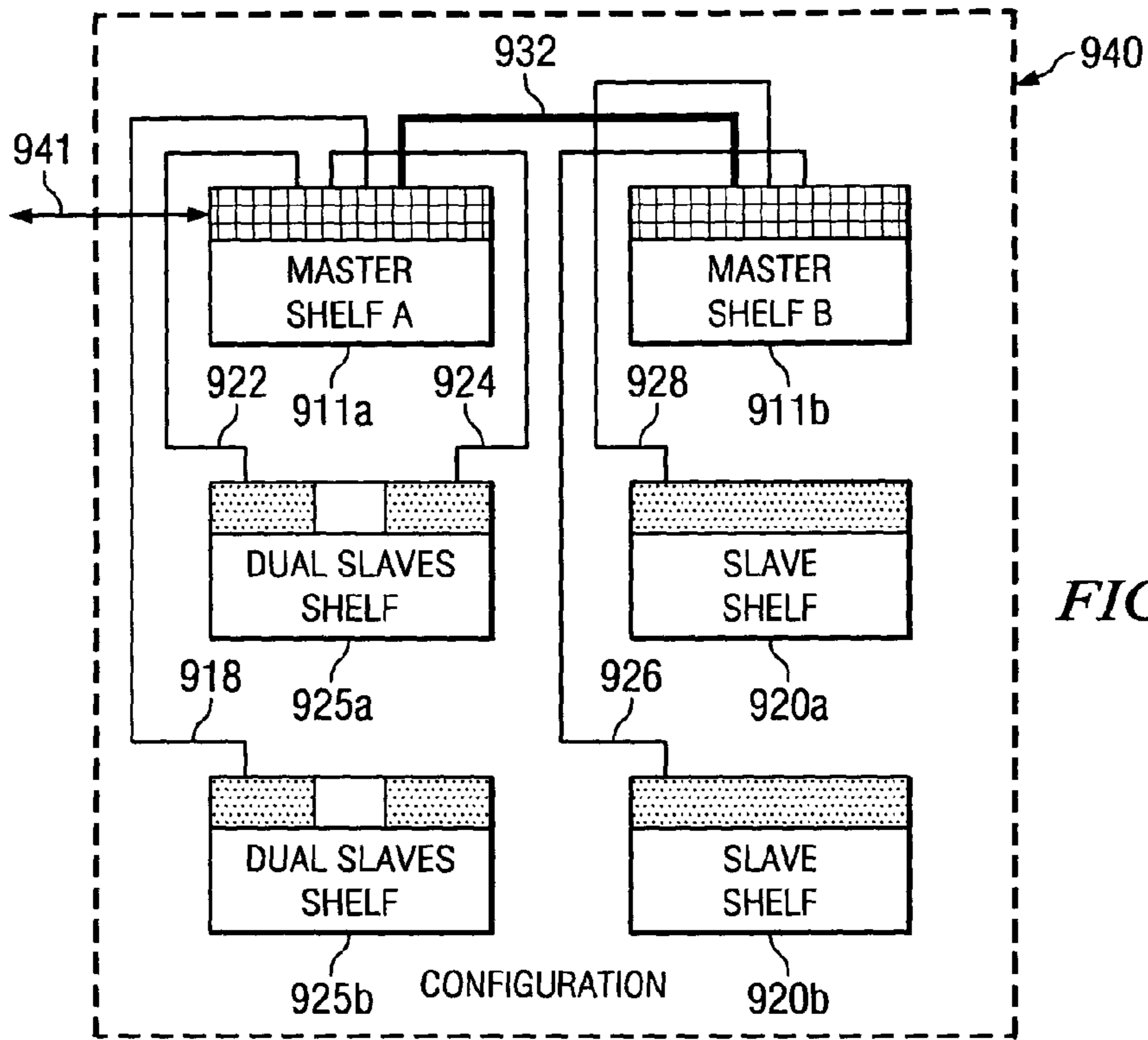

FIG. 12a

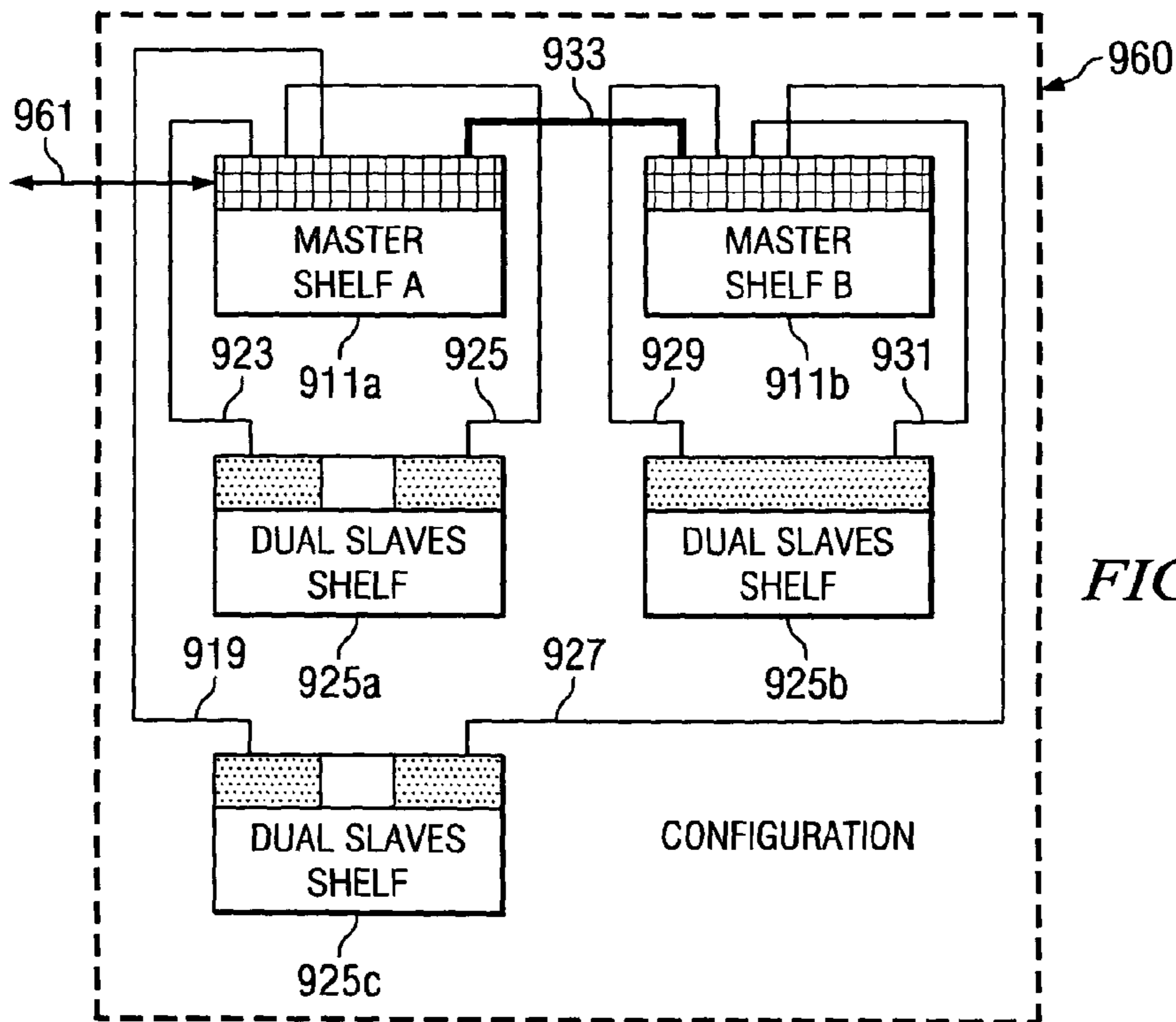

FIG. 12b

## DISTRIBUTED TERMINAL OPTICAL TRANSMISSION SYSTEM

**Matter enclosed in heavy brackets [ ] appears in the original patent but forms no part of this reissue specification; matter printed in italics indicates the additions made by reissue.**

### CROSS-REFERENCE TO RELATED APPLICATIONS

[This application claims priority to] *Notice: More than one reissue application has been filed for the reissue of U.S. Pat. No. 7,505,687. The present application is a reissue application of U.S. Pat. No. 7,505,687, and is also a continuation reissue application of U.S. application Ser. No. 13/050,755, filed Mar. 17, 2011 now U.S. Pat. No. Re.44,015, which is a reissue application of U.S. Pat. No. 7,505,687. U.S. Pat. No. 7,505,687 claims benefit of Provisional Application Ser. No. 60/368,545, entitled "Distributed Terminal Optical Network", by Jaggi, et al., filed Mar. 29, 2002.*

### FIELD OF THE INVENTION

This invention relates to a computer system for transporting optical signals between coupled metro domains using an optical transport networking system and more particularly using a lessor's optical transport networking system to transport a lessee's signal.

### BACKGROUND OF THE INVENTION

The transmission, routing and dissemination of information has occurred over computer networks for many years via standard electronic communication lines. These communication lines are effective, but place limits on the amount of information being transmitted and the speed of the transmission. With the advent of light-wave technology, a large amount of information is capable of being transmitted, routed and disseminated across great distances at a high rate over fiber optic communication lines.

In traditional optical networks, long haul (LH) and ultra-long haul (ULH) optical networks typically connect major cities. The LH and ULH optical networks can span local geographical regions, countries, continents and even large bodies of water. The construction and maintenance costs of these long haul and ultra-long haul optical networks are prohibitively large. Because of these prohibitive costs, few communication service providers own their own optical networks. Many communication service providers lease the right to transmit optical signals over another communication service provider's optical network. The communication service providers that construct their national networks through the leasing of the optical networks from other communication service providers incur disadvantages, including increased cost, versus those communication service providers that own their own optical networks.

A typical communication service provider leasing "space" on another communication service provider's optical network must provide optical data networking equipment at their own local facilities in a metropolitan area and must also provide optical data networking equipment at the lessor's facility which may be in the same metropolitan area or a short distance away in another metropolitan area. In addition to the cost of maintaining multiple sets of optical data networking equipment, there is an additional penalty from the require-

ment to use metro transmission systems to connect the lessee communication system provider's facility to the lessor communication service provider's facility and then to use the LH and ULH optical data networking equipment to traverse the LH and ULH optical network. This system results in excessive optical-to-electrical conversions and increases the operational complexity of the overall systems.

What is needed is an optical transmission system that would locate all terminal equipment in the lessee's facility. It would also be beneficial if only line amplifiers and add/drop nodes were in the lessor's facilities. The signal should undergo optical-to-electrical conversion only at the endpoints, preferably in the lessee's facility and at any regeneration points required by physical constraints.

### SUMMARY OF THE INVENTION

The present invention provides an architecture and method for transmitting signals over a network which allows for all of lessee's equipment to be located at a extension terminal in lessee's facility. It allows for efficient optical-to-electrical conversions and does not require multiple sets of optical data networking equipment.

Prior art systems suffer from the limitation that a typical communication service provider leasing "space" must provide optical data networking equipment at their own local facilities and must also provide optical data networking equipment at the lessor's facility. In addition to the cost of maintaining multiple sets of optical data networking equipment, there is an additional penalty from the requirement to use metro transmission systems to connect the lessee communication system provider's facility to the lessor communication service provider's facility and then to use the LH and ULH optical data networking equipment to traverse the LH and ULH optical network. This system results in excessive optical-to-electrical conversions and increases the operational complexity of the overall systems. In addition, prior art systems suffer from the requirement to convert customer premise equipment signals into short haul format for transport to a facility, usually a lessor's, and then at the facility, to be converted into a LH format for transport over a LH network. Certain prior art systems have attempted to address these problems with varying success.

U.S. Pat. No. 5,726,784 to Alexander, et al., entitled WDM OPTICAL COMMUNICATION SYSTEM WITH REMODULATORS AND DIVERSE OPTICAL TRANSMITTERS, discloses an invention which is capable of placing information from incoming information-bearing optical signals onto multiple optical signal channels for conveyance over an optical waveguide. A receiving system is configured to receive an information bearing optical signal at a particular reception wavelength and each receiving system must include at least one Bragg grating member for selecting the particular reception wavelength. However, Alexander is intended to provide compatibility with existing systems and does not disclose or suggest a system that allows for efficient optical-to-electrical conversions or one that would locate all terminal equipment in the lessee's facility.

U.S. Pat. No. 5,613,210 to Van Driel, et al., entitled TELECOMMUNICATION NETWORK FOR TRANSMITTING INFORMATION TO A PLURALITY OF STATIONS OVER A SINGLE CHANNEL, discloses an invention which uses a method wherein a signal to be transmitted is modulated on a subcarrier having its own frequency and then modulated on a main carrier in each sub-station. While Van Driel does utilize subcarrier multiplexing, only two wavelengths are involved and the multiplexing is therefore limited. Van Driel does not



disclose transmitting the signals over a LH network. Nor does VanDriel disclose or suggest a system that allows for efficient optical-to-electrical conversions or one that would locate all terminal equipment in the lessee's facility.

U.S. Pat. No. 5,559,625 to Smith, et al., entitled DISTRIBUTIVE COMMUNICATIONS NETWORK, discloses a method and system for increasing the amount of re-use of information transmission wavelengths within a network. A distributive communications network includes groups of nodes at different levels. At each level of nodes, wavelength traffic is either passed on to a higher level, or looped back according to the band of wavelengths to which it is assigned. Philip does not disclose or suggest a system that allows for efficient optical-to-electrical conversions or one that would locate all terminal equipment in the lessee's facility.

Other patents such as U.S. Pat. No. 5,778,116 to Tomich, entitled PHOTONIC HOME AREA NETWORK FIBER/POWER INSERTION APPARATUS, and U.S. Pat. No. 5,914,799 to Tan, entitled OPTICAL NETWORK disclose an invention that is limited to signal transfer from a central station to subscriber stations. Neither of the patents disclose a method or apparatus for transmitting signals over a LH network, disclose or suggest a system that allows for efficient optical-to-electrical conversions or one that would locate all terminal equipment in the lessee's facility.

The present invention is an improvement over the prior art because it allows for efficient optical-to-electrical conversions and does not require multiple sets of optical data networking equipment. The present invention provides for coupled metro domain networks which are a part of a larger inter-domain network. The invention facilitates optical signals generated from customer premise equipment (CPE) at the edges of the metro domain networks. The CPEs are connected to extension terminals preferably in lessee's facility. The extension terminals transform the optical signal originating at the CPE into a suitable format for long haul transmission. One or more CPEs may be connected to one or more extension terminals. The optical signal then propagates from an extension terminal to a primary terminal along a metro fiber. At the primary terminal, the optical signal is multiplexed with other optical signals from other extension terminals. The multiplexed signals are then transmitted over LH or ULH network to a second primary terminal via core fiber. The optical signal may propagate along the core fiber with the help of a chain of amplifiers and optical add/drops. The second primary terminal then demuxes the optical signal from other optical signals and transmits the demuxed signal to the proper extension terminal. At the extension terminal, the demuxed optical signal is transformed from its LH format back into a format suitable for inter-connection to a CPE. Using this architecture, the signal under goes optical-to-electrical conversion only at the extension terminals. These extension terminals can be located in lessee's facility. The only equipment located in lessor's facility is the primary terminal containing line amplifiers and add/drop nodes. The transport system meets the networking requirements of intercity connections without the need for complex and costly metro transport gear. Also, the core extension terminals may be physically distributed across several metro network nodes.

The invention will be better understood from the following more detailed description taken in conjunction with the accompanying drawings.

#### DETAILED DESCRIPTION OF THE DRAWINGS

A better understanding of the invention can be obtained from the following detailed description of one exemplary embodiment as considered in conjunction with the following drawings in which:

FIG. 1 is a block diagram depicting a prior art inter-domain optical networking between core networks and metro/regional networks;

FIG. 2 is a block diagram of the detail of the prior art end-terminals and the interconnections between optical transport systems in FIG. 1;

FIG. 3 is a block diagram depicting an inter-domain optical transport system according to the present invention;

FIG. 4 is a block diagram of the detail of a primary terminal for use in the present invention;

FIG. 5 is a block diagram of a type one extension terminal for use in the present invention;

FIG. 6 is a block diagram of a type two extension terminal for use in the present invention;

FIG. 7 is a block diagram showing a multiplexer-demultiplexer architecture based on optical interleaver and deinterleaver filters for use in the present invention;

FIG. 8 is a block diagram showing a multiplexer-demultiplexer architecture based on banded DWDM filters for use in the present invention;

FIGS. 9a and 9b are block diagrams showing a tunable demultiplexer architecture for use in the present invention;

FIGS. 10a and 10b are block diagrams showing a tunable multiplexer for use in the present invention;

FIG. 11 is a block diagram of shelf configurations according to the present invention; and

FIGS. 12a and 12b are block diagrams of alternate shelf configurations according to the present invention.

#### DETAILED DESCRIPTION OF EXEMPLARY EMBODIMENTS

In the descriptions that follow, like parts are marked throughout the specification and drawings with the same numerals, respectively. The drawing figures are not necessarily drawn to scale and certain figures may be shown in exaggerated or generalized form in the interest of clarity and conciseness. Reference of an A-Z signal or direction means from the left side of the drawing to the right side of the drawing while Z-A means from the right side to the left side. The A-Z or Z-A designation is used for illustrative purposes only.

The prior art as it relates to optical transport networking between domains is shown in FIG. 1 and FIG. 2. Referring to FIG. 1, an optical transport network may be composed of several domains: a core network 100 with a geographic extent of typically between 100 km and 1500 km and a plurality of metro network domains 130a-d with geographic extents typically of 3 km to 100 km.

Customer premise equipment (CPE) 190a-h are considered to be outside metro domains 130a, 130b, 130c, and 130d. CPE 190a-h is sometimes referred to as client equipment or end-user equipment. CPE 190a-h are connected to metro domain 130a-d via interoffice fiber, 151c, 151d, 151e, 151j-l, and 151p-s.

Metro domains 130a-d vary widely in extent, interconnection, and in the types of systems that are deployed within them. Metro domain 130a shows a plurality of ring-protected systems. Metro domain 130a is composed of primary ring end terminal 135a, extension ring end terminal 136a, primary multi-node terminal 145, and extension multi-node terminals 146a and 146b. Optical signals are propagated to and from primary ring end terminal 135a and extension ring end terminal 136a on metro fibers 152a and 152b. Optical signals may propagate on either or both legs of the ring so that in the event fiber 152a or fiber 152b fails, a connection is continually

maintained between primary ring end terminal **135a** and extension ring end terminal **136a**.

A more complex, multi-node protected ring is indicated by primary multi-node ring end terminal **145** and extension multi-node ring end terminals **146a** and **146b**, whereby, all three nodes are interconnected via metro fiber **152c** and **152d**. Metro fiber **152c** and **152d** may be a single fiber or a plurality of fibers. Methods for ring protection are well known in the art and will not be discussed further.

Metro domain **130b** is different from metro domain **130a** in that metro domain **130b** consist of primary end terminals **125a-c** and extension end terminals **126a-c** being connected by metro fiber **152e-g** in a linear fashion as opposed to a ring protected system as shown in metro domain **130a**. Metro domain **130b** provides a network consisting of a plurality of unprotected linear links where the optical signals are propagated along a single path of fiber in an unprotected way. For example, if metro fiber **152e** is cut or fails, then optical signals terminating at and originating from CPE **190d** will no longer be connected with core end terminal **110c**. By the interconnection of CPE **190e** to extension end terminals **126b** and **126c** and extension end terminals **126b** and **126c** being connected to core end-terminal **110c** via primary end terminal **125b** and **125c** an economical path protection can be realized at the client equipment layer. Path protection at the client equipment layer is realized because if one interconnection of CPE **190e** to either extension end terminal **126b** or **126c** fails, the other interconnection can still transmit signals to **110c**.

Metro domain **130c** indicates a combination of protected and unprotected links. Primary end terminal **125d** is connected to extension end terminal **126d** in a linear fashion via fiber **152h**. Primary end terminal **135b** is connected to extension end terminal **136b** in a ring-protected system via fibers **152i** and **152j**. Primary end terminal **125e** is connected to extension end terminal **126e** via metro fiber **152k**. Core end terminal **10b** is ultimately connected to CPE **190h** by the transiting link of primary end terminal **125f** and extension end terminal **126f** in domain **130d** via fiber **152m** and by the transiting link of primary end terminal **125e** and extension end terminal **126e** in domain **130c** via fiber **152k**. Secondary end terminal **126e** is connected to primary end terminal **125f** via multiple fiber **151r**. Such architecture may occur, for example, because the geographical distance between core end terminal **110b** and CPE **190h** is too large for one domain. More relevant to this invention, the situation may occur because different entities own and manage the two domains **130c** and **130d** and there is no way to connect domain **130d** to core end-terminal **110b** without some type of intermediate equipment and associated fiber.

Metro systems may multiplex more than one optical signal onto a single fiber using methods that are well known in the art as such as code wave division multiplexing (CWDM), wavelength division multiplexing (WDM), or dense wavelength division multiplexing (DWDM) methods. Starting from core end-terminal **110b** in the core network **100**, a plurality of tributary signals are interconnected and terminated on primary end terminal **125e** via multiple fiber **151o**. Primary end terminal **125e** muxes the plurality of tributary signals together and transmits the muxed signals to extension end terminal **126e** via metro fiber **152k**. Secondary end terminal **126e** demuxes the plural tributary signals and transmits them via multiple pairs of intra-office fibers **151r** to primary end terminal **125f** in domain **130d**. Primary end terminal **125f** muxes the plurality of tributary signals together and transmits the muxed signals to extension end terminal **126h** via metro fiber **152m**. Finally, extension end terminal **126h** demuxes the plural tributary signals and connects them, via multiple intra-

office fibers **151s** to CPE **190h** where the signals terminate. If the signals originated at CPE **190h** the process would be reversed.

Core network **100** is sometimes referred to as a long haul network and may be composed of a plurality of linear DWDM systems or more complex ring structures employing SONET ADMs or a mix of each type. A linear DWDM system is shown in FIG. **1**. Signals are transferred into and out of core network **100** by core end terminals **110a-c** via intra-office fiber **151a**, **151b**, **151f-i**, and **151m-o**. The tributary interfaces will be described in more detail in FIG. **2** as are the methods used to transmit signals through the core end terminals **110a-c**. The transmitted signals from one core end terminal **110a-c** propagate through a set of core optical amplifiers **115a-d** and optical add-drop multiplexing device (OADM) **116** on core fiber **150a**, **150x**, and **150z** before reaching a second core end terminal **110a**, **110b**, and **110c** where the signals are transmitted into a metro network domain **130a-d**.

Core amplifiers **115a-d** perform the function of compensating for loss of optical signal power as the optical signals propagate through core fiber **150a**, **150x**, and **150z**. The amplifiers are spaced typically 60 km to 120 km apart. The ellipsis in the drawing indicates that there could be any number amplifiers between **115a** and **115b** and between **115c** and **115d**. Also, there may be more than one OADM along core fiber **150a**, **150x** and **150z**. OADM **116** performs the function of extracting and inserting optical signals from core fiber **150a**, **150x** and **150z**, and placing or acquiring the signals on or from intra-office fiber **151a**, **151b**, **151f-i**, and **151m-o**.

In FIG. **2**, the details of signals paths from core fiber **150** (shown as a block), core end terminal **110**, primary end terminals **125g** and **125h**, to the metro fiber **152n** and **152o** (shown as blocks) are shown. These signals paths occur between, for example, **110c** and **125a-c** in FIG. **1**. With the exception of core fiber **150** and metro fiber **152n** and **152o**, all the elements of FIG. **2** are physically co-located in a metro central office (CO) or a core network point-of-presence (POP) facility. Moreover, typically all end-terminal components in core end terminal **110** and metro terminal **125g** and **125k** must be co-located in the same facility and within adjacent bays according to prior art.

Continuing in FIG. **2**, intra-office fibers usually consist of a fiber pair, for example intra-office fiber **151t-1** and **151u-1**, whereby the transmit and receive optical signals usually propagate on separate fibers. Optical or WDM signals from core fiber **150** enter core end terminal **110** via intra-office fiber **151t-1**. Intra-office fiber **151t-1** is connected to optical amplifier **155** where the propagating signals are amplified. Optical amplifier **155** is further connected to DWDM demux **165** via core end terminal fiber **161a**. Core end terminal fiber **161a** carries composite optically muxed signals. The composite signals are deconstructed into their constituent and individual optically modulated signals by DWDM demux **165** and appear on fiber interconnects **163a-c**. Optical signals on fiber interconnects **163a-c** are received by Long Haul (LH) transponders **160a-c**. LH transponders **160a-c** electrically process and optically remodulate the signals, and transmit the LH remodulated signals through tributary interfaces **151v-1** and **152v-2** to short haul (SH) transponders **170a** and **170b** or SH transceiver **180** via intra-office fibers **151v-3**.

LH transponders **160a-c** may be varied in their capability and composition. For example, they may employ internal modulation or external modulation using NRZ, RZ, or other formats as known by those skilled in the art. LH transponders **160a-c** have the primary function of converting short and intermediate reach intra-office signals typically generated by directly modulated lasers to long reach signals; long reach

signals (LH format) being compatible with intercity propagation of hundreds or thousands of kilometers.

The SH transponders **170a** and **170b** and SH transceiver **180** may be of different varieties typically found in metro domain systems and known well to those skilled in the art. The distinguishing feature of SH transponder **170a** and **170b** and SH transceiver **180** from LH transponders **160a-c** is in the propagation distance limitation on the SH transponders **170a** and **170b** and SH transceiver **180**. SH transponders **170a** and **170b** and SH transceiver **180** have a propagation distance limited to less than or about 80 km.

The term transponder applies to both the LH and SH applications wherein the input optical signal to the device is narrow band and occurs at a particular input wavelength or frequency and wherein the device converts the input signal to an output optical signal of a different wavelength or frequency and may be narrowband or broadband in nature. In general, a transponder will operate in full-duplex mode. The term transceiver applies to a device that converts input signals at a particular wavelength or frequency to an output signal at the same wavelength or frequency while maintaining similarity between the optical bandwidth and dispersive capacity of the input signal to the optical bandwidth and dispersive capacity of the output signal.

Both LH and SH devices perform the functions of regeneration or amplification and reshaping, and may or may not employ retiming. Further details of the LH or SH receiver technology and transmitter technology, that is the transponders and transceivers, are known in the art and will not be described further. Continuing the description of FIG. 2, the optical signals on intra-office fibers **151v-1**, **151v-2**, and **151v-3** are received by SH transponders **170a** and **170b** and SH transceiver **180**. The optical signals on **151v-3** are converted by transponder **180** to optical signals that propagate directly on the intra-office fibers **151x-2** to metro fiber **152o**. Alternatively, the optical signals appearing on intra-office fiber **151v-1** and **151v-2** are converted by SH transponders **170a** and **170b**, respectively, to intermediate signals and transmitted to WDM mux **175** via fiber interconnect **173a** and **173d**, respectively. WDM mux **175** muxes the intermediate signals and transmits them to the metro fiber **152n** via intra-office fiber **151x-1** and ultimately to a extension end terminal.

In the Z-A direction, optical signals from metro fiber **152n** propagate along intra-office fiber **151y-1** to WDM demux **176**. WDM demux **176** extracts the optical signals propagated along intra-office fiber **151y-1**, and transmits the extracted signals to SH transponders **170a** and **170b** via interconnects **173b** and **173c**. SH transponders **170a** and **170b** electronically process and optically remodulate the extracted signals for transport over a SH network and transmit the remodulated signals to LH transponders **160a** and **160b** via intra-office fibers **151w-1** and **151w-2**. LH transponders **160a** and **160b** convert the signals for into a format suitable for LH transporting and transmits the prepared signals to DWDM mux **166** via fiber interconnects **163d** and **163e**.

Optical signals from metro fiber **152o** propagate along intra-office fiber **151y-2** to SH transceiver **180**. SH transceiver **180** electronically processes and optically remodulates the extracted signals for transport over a SH network and transmits the remodulated signal to LH transponder **160c** via intra-office fiber **151w-3** and tributary interface **155c**. LH transponder converts the signal into a format suitable for LH transporting and transmits the prepared signal to DWDM mux **166** via fiber interconnect **163f**.

DWDM mux **166** muxes the signals received from fiber interconnects **163d-f** and transmits the muxed signals to transmitting optical amplifier **156** via core end terminal fiber

**161b**. Transmitting optical amplifier **156** amplifies the muxed signals and transmits the amplified signals to core fiber **150** via intra-office fiber **151u-1**.

The preferred and alternate embodiments of the invention are described with reference to FIGS. 3-12. Beginning with FIG. 3, the invention includes a set of coupled metro networks **230a-d** which are a part of a larger inter-domain network **200**. The metro networks **230a-d** are connected by a plurality of linear DWDM systems or more complex ring structures employing SONET ADMs or a mix of each type. A linear DWDM system is shown in FIG. 3, but the invention encompasses other structures. The invention facilitates optical signals generated from CPE **290a-p** at the edges of metro networks **230a-d** to be interconnected directly with each other. CPEs **290a-p** are the same type as CPEs **190a-h** shown in FIG. 1. Those skilled in the art will recognize that the configuration of metro network domains may take many forms and that those depicted are exemplary. Similarly, the invention can be applied to a widely varying arrangement of interconnections of metro optic networks, as will be appreciated by those skilled in the art. CPEs **290a-d**, **290f-i** and **290l-p** are in communication with extension terminals **220a-h** via intra-office fiber **251a-d**, **251g-i** and **251o-s**. Intra-office fibers **251a-s** are the same type of fiber as intra-office fibers **151a-s** shown in FIG. 1. CPE **290d** is connected to primary terminal **210a** via intra-office fiber **251e**. CPE **290e** is connected to primary terminal **210c** via intra-office fiber **251f**. CPEs **290j** and **290k** are connected to primary terminal **210b** via intra-office fibers **251k** and **251l**.

Extension terminals **220a-f** are connected to primary terminals **210a** and **210c** via metro fiber **252b-d** and **252f-h**. Metro fiber **252a-k** is the same type of fiber as metro fiber **152a-m**. Primary terminals **210a** and **210c** are connected to junctions **211a** and **211b** via metro fiber **252a** and **252e**. Extension terminal **220g** is connected to junction **211c** via metro fiber **252i**. Extension terminal **220h** is connected to junction **211e** via metro fiber **252k**. Junction **211e** is connected to junction **211d** via metro fiber **252j**. Junction **211a** is connected to core amplifier **215a** via core fiber **250a**. Amplifiers **215a-d** are the same type of amplifiers as **115a-d**. Core fiber **250a**, **250x** and **250z** is the same type of fiber as core fiber **150a**, **150x** and **150z**.

Junction **211b** is connected to OADM **216** via interoffice fiber **251u**. Junctions **211c** and **211d** are connected to primary terminal **210b** via intra-office fiber **251m** and **251n**. Also connected to primary terminal **210b** are CPE **290j** and **290k** through intra-office fiber **251k** and **251l**.

To accomplish the interconnection of metro networks **230a**, **230b**, **230c**, **230d**, core optical amplifiers **215a-d** are connected to OADM **216** via core fiber **250a**, **250x** and **250z**. The ellipses in the drawing indicate there can be any number of core amplifiers **215a-d** between junction **211a** and OADM **216** and between primary distributed terminal **210b** and OADM **216**. Also, there may be more than one OADM **216** along core fiber **250a**, **250x** and **250z**. Either OADM **216** or core amplifiers **215a-d** are connected to a sub-system of primary terminals **210a-c** and extension terminals **220a-h** composed of terminal shelves. CPE **290a-p** may be interconnected directly to primary terminals **210a-c** or extension terminals **220a-h** to accomplish the transfer of optical signals from a particular CPE to a different CPE that may be in a geographically distinct location. OADM **216** can be fixed or not fixed as in broadcast and select architectures. In the preferred embodiment, OADM **216** includes a broadcast and select architecture as is known in the art. Core optical amplifiers **215** and OADM **216** may or may not contain components to perform optical dispersion compensation and other

components to perform gain equalization, both of which may employ techniques known in the art.

Referring to FIG. 3, a link between CPE 290a and CPE 290p in the A-Z direction of a full-duplex signal path will now be described as an example. CPE 290a is connected to extension terminal 220a via intra-office fiber 251a. Extension terminal 220a transforms the signal originating at 290a into a suitable format for LH transmission. Extension terminal 220a transmits the transformed signal to primary terminal 210a via metro fiber 252b. At primary terminal 210a, the transformed signal is optically muxed with other signals from extension terminals 220b and 220c and with signals generated at CPE 290d. The multiplexed signals are transmitted to junction 211a via metro fiber 252a. At junction 211a, metro fiber 252a is connected to core fiber 250a and the optical signal propagates along core fiber 250a, 250x and 250z through the chain of core amplifiers 215a-d and OADM 216 to the primary distributed terminal 210b. At primary distributed terminal 210b, the desired signal for CPE 290p is optically demuxed from the other signals and transmitted along intra-office fiber 251n to junction 211d. At junction 211d, intra-office fiber 251n is coupled to metro fiber 252j. The desired optical signal propagates along metro fiber 252j to junction 211e. At junction 211e, metro fiber 252j is coupled to metro fiber 252k. The desired optical signal continues to propagate on metro fiber 252k to extension terminal 220h. At extension terminal 220h, the desired optical signal is received and transformed from its LH format into a format suitable for interconnection with CPE 290p through intra-office fiber 251s. The optical signal terminates at CPE 290p. In the Z-A direction of the full duplex signal can be described in a similar way, so that signals originating from CPE 290p and terminating at CPE 290a are propagated in a similar manner.

There are many optical links that can be established in the inter-domain network 200. For example, the present invention allows for CPE 290c to be interconnected to any one of the other CPE shown in FIG. 3. Also, more than one CPE may be connected to a single extension terminal or primary terminal. For example, CPE 290a and CPE 290b are both connected to extension terminal 220a. CPE 290a and 290b may be co-located together or geographically separate and neither CPE 290a or 290b need be co-located with extension terminal 220a. Although in practice they are usually co-located and interconnected by intra-office fiber 251a and 251b as shown. Additionally, one CPE may be connected to a plurality of extension terminals or primary terminals. For example, CPE 290c is shown having at least two distinct optical interfaces, one being connected to extension terminal 220b and the other connected to extension terminal 220c. By interconnecting extension terminals 220b and 220c to primary terminal 210a with metro fiber 252c and 252d, a protected connection can be made between CPE 290c and primary terminal 210a. If a fiber failure occurs on either metro fiber 252c or 252d the other metro fiber 252c or 252d may carry the optical signals safely from CPE 290c to other points in inter-domain network 200.

Another link example will illustrate further features of the current invention. Simultaneous multiple interconnections between metro networks 230b and 230c consisting of links between CPE 290e to CPE 290o, CPE 290h to CPE 290k, and CPE 290i to CPE 290p is described. In particular, CPEs 290h and 290i are connected to extension terminal 220f via intra-office fiber 251i and 251j, respectively. Secondary terminal 220f converts the originating signals from CPEs 290h and 290i to a LH format. Secondary terminal 220f optically muxes the converted signals and transmits the muxed signals to primary terminal 210c via metro fiber 252h. Also, CPE

290e is connected to primary terminal 210c via intra-office fiber 251f and transmits an SH signal to primary terminal 210c.

At primary terminal 210c, the optical signal originating from CPE 290e is converted to a LH format and optically muxed with the other optical signals originating from extension terminal 220f. The muxed optical signals from primary terminal 210c propagate on metro fiber 252e to junction 211b. The signals propagate through junction 211b to intra-office fiber 251u and continues on to OADM 216. OADM 216 muxes the signals from intra-office fiber 251u onto core fiber 250x. The optical signals propagate on core fiber 250x and 250z towards primary terminal 210b. Multiple core amplifiers 215c and 215d may be used to boost the signal. Additional OADMs 216 may also be present on core fiber 250x and 250z.

At primary terminal 210b, the optical signals on core fiber 250z are optically demuxed in such a way that optical signals destined for CPE 290e and CPE 290i are transmitted on intra-office fiber 251n while optical signals destined for CPE 290h are transmitted on intra-office fiber 251l. The signal on intra-office fiber 251l terminates at CPE 290k and the signal from CPE 290h has been successfully transmitted to CPE 290k. CPE 290k is considered local to core distributed terminal 210b.

The signals originating from CPE 290e and CPE 290i on intra-office fiber 251n propagate along intra-office fiber 251n through junction 211d and onto metro fiber 252j inside metro network 230c. The LH signals propagate along metro fiber 252j through junction 211e and onto metro fiber 252k inside metro network 230d. The optical signals propagate along metro fiber 252k to extension terminal 220h. At extension terminal 220h, the optical signals are demuxed and converted from a LH format to a format suitable for interconnection to CPEs 290o and 290p. The converted signals are transmitted to CPEs 290o and 290p via intra-office fiber 251r and 251s, respectively, where the signals terminate. The signal from CPE 290e has been successfully transmitted to CPE 290o and the signal from 290i has been successfully transmitted to CPE 290p. In the Z-A direction of the full duplex signal can be described in a similar way so that originating signals from 290k, 290r, and 290q destined for 290h, 290e, and 290i respectively, are propagated in a similar manner to that just described.

The above explains how a signal may propagate through more than one metro network 230 without conversion from an LH format. In the preferred embodiment, the links between primary terminals 210a-c and extension terminals 220a-h may be more than 100 km and may include optical amplifiers with or without dispersion compensators and gain equalizers.

The invention allows for primary terminals 210a-c to be placed outside or within a metro network 230 as required by the location of CPEs 290a-p. Primary terminals 210a and 210c are inside respective metro networks 230a and 230b while primary terminal 210b is outside metro networks 230c and 230d.

The invention also allows for remote interconnections between OADM 216 and primary terminals 210a-c to be of distances greater than those found in most interoffice networks. The distance for the remote interconnection is similar in nature to the long distances between primary terminals 210a-c and extension terminals 220a-p and could be around 100 km. Interconnection between primary terminals 210a-c, extension terminals 220a-h and OADM 216 are accomplished with a single pair of fibers. This feature is further described in relation to FIG. 4.

FIG. 4 depicts the preferred embodiment of a primary terminal. Primary terminal 210 allows for the interconnection

of full duplex signals from core fiber **250** (shown as a block) to various distinct CPEs **290s-x**. CPEs **290s-x** are the same type as CPEs **290a-p** FIG. **3** and CPEs **190a-h** FIG. **1**. CPEs **290s-x** may be geographically diverse from one another. In the A-Z direction, an LH format optical signal is transmitted from the core fiber plant **250** to receiving amplifier **255** via intra-office fiber **251v-1**. Intra-office fibers **251v-a**, **251x-1**, **251x-2**, **251x-3**, **251y-1**, **251y-2**, **251y-3**, **251z-1**, **251z-2**, **251z-3**, **251z-4**, **251z-5**, **251z-6**, **251w-1** are the same type of fiber as intra-office fibers **251a-s** and **151a-s**. Receiving amplifier **255** performs the function of amplifying the incoming multiplexed WDM or DWDM signals from intra-office fiber **251v-1** to a known level, so the signal has enough optical power to transmit to other components such as extension terminals **220i-k**. The amplified signal is transmitted to fine demux **265** via fiber **261a**. The signal can contain any number of muxed optical signals. In the preferred embodiment, there are twelve optical signals, referred to as M (12) to denote any arbitrary number of twelve signals.

Fine demux **265** demuxes the M (12) muxed signals in such a way as to leave N (4) smaller groups of M/N (3) optical signals. The N (4) smaller groups are muxed onto 4 intra-office fiber interconnections **271a-d**. These smaller groups of approximately M/N (3) optical signals will be called "optical mux groups" or simply "mux groups" hereinafter. One mux group on intra-office fiber interconnection **271a** remains inside the primary terminal **210** for further processing while the other mux groups on intra-office fiber interconnections **271b-d** exit for distribution to distinct locations, such as CPE **290v-x**.

The mux group on fiber interconnection **271a** is transmitted from fine demux **265** to coarse demux **267**. Coarse demux **267** demuxes the approximately M/N (3) optical signals into individual optical signals and transmits the individual signals to transponders **260a-c** via output fiber connections **263a-c**. Transponders **260a-c** convert the individual LH format signals into optical signals for transmission on intra-office optical fibers **251x-1**, **251x-2**, and **251x-3**. The transmitted optical signals are suitable for use by CPEs **290s-u**, and therefore the primary terminal **210** serves as the interface device for the local traffic (optical signals) intended for CPEs **290s-u**. As shown by the ellipsis, there may be a plurality of CPEs **290** connected to any one of the transponders **260a-c**.

For the delivery of remote traffic (optical signals) to remote CPE **290v-x**, fine demux **265** transmits the mux groups on intra-office fiber interconnections **271b-d** to metro fiber **252**. The optical mux groups are transported from metro fiber **252** to extension terminals **220i-k** via geographically distinct fiber interconnections **271e-i**. Secondary terminals **220i-k** demux the optical mux groups into individual optical signals and transmit the individual signals to CPEs **290v-x** via intra-office fibers **251z-1**, **z-3**, and **z-5**. As shown by the ellipsis, there may be a plurality of CPEs connected to any one of the extension terminals **220i-k**.

The optical signals, being in full duplex, also flow in a direction opposite to that just described and in a similar way. Individual optical signals that originate from CPE **290v-x** are transmitted to extension terminals **220i-k** via intra-office optical fibers **251z-2**, **z-4**, **z-6**. Secondary terminals **220i-j** mux the optical signals into optical mux groups and transmit the mux groups to metro fiber **252** via fiber interconnections **271f**, **271h**, and **271j**. The optical mux groups propagating on metro fiber **252** are transmitted to fine mux **266** via fiber interconnections **271f-h**. The optical mux groups are muxed into one mux group by fine mux **266**. Fine mux **266** transmits a signal containing the mux group to output amplifier **256** via

fiber **261b**. Output amplifier **256** then amplifies the signal for transmission on intra-office fiber **251w-1** to core fiber **250**.

Similarly, optical signals originating from CPEs **290s-u** flow in the Z-A direction through transponders **260a-c** via intra-office fiber **151y-1**, **151y-2** and **151y-3**. Transponders **260a-c** convert the individual optical signals to a LH format and send the converted signals to coarse mux **268** via output fiber connection **263d-f**. Coarse mux **268** muxes the converted signals together into an optical mux group and transmits the optical mux group to fine mux **266** via fiber interconnection **271e**. The optical mux groups propagating on fiber interconnections **271e-h** are muxed into one mux group by fine mux **266**. Fine mux **266** transmits the signal containing the mux group to output amplifier **256** via fiber **261b**. Output amplifier **256** then amplifies the signal for transmission on intra-office fibers **251w-1** to core fiber **250**. The combination of primary terminal **210** and extension terminals **220i-k** form a system of distributed terminals, which is a preferred embodiment of the present invention.

In FIG. **5**, the preferred embodiment of a type one extension terminal **220** is shown. A mux group containing approximately M/N, for example 3, optical signals is propagated from metro fiber **252** (shown as a block) to terminal **220** via fiber interconnection **271k**. The mux group traverses terminal **220** receiving amplifier **285** which may be or may not be the same type of amplifier as receiving amplifier **255** in primary terminal **210**, FIG. **4**. Terminal **220** receiving amplifier **285** amplifies the incoming approximately M/N (3) multiplexed optical WDM or DWDM signals from **271k** to a known level so the signals have enough optical power to be transmitted to the other components in type one extension terminal **220** and connecting devices such as CPE **290aa-cc**. The approximately M/N (3) multiplexed optical signals are transmitted from extension terminal receiving amplifier **285** to extension terminal coarse demux **287** via extension terminal interconnection **281a**. Secondary terminal coarse demux **287** demuxes the approximately M/N (3) multiplexed optical signals into individual optical signals for transmission to transponders **260d-f** via extension terminal output fiber connections **283a-c**. Transponders **260d-f** are the same type of transponders as transponders **260a-c** in FIG. **4**.

Transponders **260d-f** convert the LH format optical signals on extension terminal output fiber connections **283a-c** into signals suitable for use by CPEs **290aa-cc**. Transponders **260d-f** are connected to CPE **290aa-cc** via intra-office fibers **251aa-1**, **251aa-2** and **251aa-3**.

Terminal **220** serves as the interface device for the local traffic (optical signals) intended for CPE **290aa-cc**. Intra-office fibers **251aa-1**, **251aa-2** and **251aa-3** are usually physically co-located with terminal **220**, but they may incorporate long reach capability including optical amplifiers to connect to an individual port on a remote CPE **290** via an intra-office fiber.

The full duplex optical signals also flow in the Z-A direction, from CPEs **290aa-cc** through intra-office fibers **251bb-1**, **251bb-2** and **251bb-3** to transponders **260d-f**. Transponders **260d-f** convert the signal formats used by CPEs **290aa-cc** to a LH format. The converted LH format signals are sent to extension coarse mux **288** via extension terminal output fiber connections **283d-f**. Secondary terminal coarse mux **288** combines the optical signals into an optical mux group and transmits the optical mux group to optical amplifier **286** via extension terminal interconnection **281b**. The mux group is amplified by terminal **220** transmitting optical amplifier **286** for propagation along fiber interconnection **271m** to metro fiber **252** and on to a primary terminal **210** (FIG. **4**).

The preferred embodiment of a type one extension terminal **220** is capable of transmitting and receiving signals from primary terminal **210** from distances on the order of but possibly even larger than 100 km. For distances much larger than 100 km a stand-alone optical amplifier or chain of such devices can be inserted between the extension terminals and the primary terminal.

A type two extension terminal **225** is depicted in FIG. 6. Terminal **225**, can be used for short distance connections, of the order of 5 km or less, that require a physical separation between the primary terminal **210** and multiple CPEs. The primary difference between a type two extension terminal **225** and type one extension terminal **220** is that receiving optical amplifier **285** and transmitting amplifier **286** are not found in type two terminal **225**. With the exception of the optical amplifiers, the signal propagation is the same to that described for type one extension terminal **220**.

In the A-Z direction, an optical mux group containing approximately M/N optical signals are propagated from metro fiber **252** (shown as a block) to type two extension terminal **225** via fiber interconnection **271p**. The optical mux group propagates to short extension coarse demux **297**. Coarse demux **297** demuxes the approximately M/N (3) optical signals into individual optical signals and transmits the individual signals to transponders **260g-i** via terminal output fiber connections **293a-c**. Transponders **260g-i** are the same type of transponders **260d-f** as shown in FIG. 5.

Transponders **260g-i** convert the LH format optical signals on output fiber connections **293a-c** into signals suitable for use by CPEs **290pp-rr**. Transponders **260g-i** are connected to CPEs **290pp-rr** via intra-office fibers **251cc-1**, **251cc-2** and **251cc-3**.

Terminal **225** can also serve as the interface device for the local traffic (optical signals) intended for CPE **290pp-rr**. Intra-office fibers **251cc-1**, **251cc-2** and **251cc-3** are usually physically co-located with terminal **225**, but they may incorporate long reach capability including optical amplifiers to connect to an individual port on a remote CPE **290** via intra-office fiber **251**.

The full duplex optical signals also flow in the Z-A direction from CPE **290pp-rr** through intra-office fibers **251dd-1**, **251dd-2** and **251dd-3** to transponders **260g-i**. Transponders **260g-i** convert the optical signal formats from that used by CPEs **290pp-rr** to a LH format. The converted LH format signals are sent to terminal coarse mux **297** via terminal output fiber connections **293d-f**. Coarse mux **298** combines the optical signals into an optical mux group for propagation along fiber interconnection **271q** to metro fiber **252** and on to primary terminal **210**.

In both terminal **220** and terminal **225**, coarse demux **287**, terminal coarse demux **297**, coarse mux **288**, and coarse mux **298** may perform the function of attenuating the individual optical signals. In this way, the invention can launch or detect the appropriate optical powers without the need of gain equalization provided by optical amplifiers. Furthermore, the attenuation function in extension terminal coarse demux **287** and extension terminal coarse mux **288** alleviate the need for tightly controlled gain equalization in the extension terminal receiving optical amplifier **285** and transmitting optical amplifier **286** thereby lowering the cost.

FIGS. 7, 8, 9a, 9b, 10a and 10b depict various embodiments of mux and demux architectures which constitute a part of the invention. In FIG. 7, mux **500** is made up of two submultiplexers **550a** and **550b**. Submuxers **550a** and **550b** are capable of taking four times N optical signals at different wavelengths and combining them onto one output fiber connection **515a** and **515b**. N can be any number; for example, 10 as shown in

FIG. 7. Mux **500** is capable of taking 8×N (10) optical signals at different wavelengths and combining them onto one output optical connection **505**. Thus, the architecture is scaleable up or down in the number of wavelengths, for example a 50125 GHz interleaver may be placed in conjunction with two muxs **500** to form a 16×N multiplexer unit.

The function of an optical interleaver is to combine a “comb” of optical wavelengths consisting of even and odd numbered wavelengths ordered by integers as a monotonically increasing sequence with wavelength or frequency of the optical carrier. The function of an optical de-interleaver is to separate a “comb” of optical wavelengths consisting of even and odd numbered wavelengths ordered as before. Specific interleaver or de-interleaver device implementations are known in the art and will not be described further. Interleavers known in the art and can be obtained from, for example, JDS Uniphase, model number IBC-LW1D00310.

In what follows, the muxing function will be described along with the demuxing function that utilizes the same basic architecture and connectivity. Demuxing is described in parentheses. In the A-Z direction, Z-A in parentheses, signals enter (leave) mux **500** through a set of 400 GHz filters **540a-h**, known in the art as optical thin film filters or layered dielectric optical filters and available from JDS Uniphase as model number DWS-2F3883P20.

Filters **540a** and **540b** mux (demux) the received N (10) optical signals together (apart) into (from) a “comb” of wavelengths separated by 400 GHz and connected to 400/200 GHz interleaver **530a** by fiber connections **535a** and **535b**. Because an interleaver for signals in the A-Z direction is also a deinterleaver for signals in the Z-A direction, the term interleaver will be used to describe both an interleaver and deinterleaver. Similarly, 400 GHz filter pairs **540c** and **540d**, **540e** and **540f**, and **540g** and **540h** mux (demux) together (apart) the received optical signals into (from) a “comb” of wavelengths separated by 400 GHz. The filter pairs **540c** and **540d**, **540e** and **540f**, and **540g** and **540h** are in communication with 400/200 GHz interleavers **530b**, **530c** and **530d**, respectively, via 400/200 GHz fiber connections **535c-h**, respectively. 400/200 GHz interleavers **530a-d** combine (separate) optical signals from (for) filters **540a-h** into (from) a single “comb” of wavelengths separated by 200 GHz. The combined (separated) output (input) is transmitted (received) to (from) 200/100 GHz interleaver **520a** via 200/100 GHz fiber connection **525a** and **525b** where they are combined (separated) into (from) a single “comb” of wavelengths 100 GHz apart. Similarly, output from **530c** and **530d** propagate via fiber connection **525c** and **525d** to (from) interleaver **520b** where they are combined (separated) into (from) a single “comb” of wavelengths 100 GHz apart. Finally, the output (input) “combs” of interleavers **520a** and **520b** are transmitted to (from) 100/50 GHz interleaver **510** via 100/50 fiber connections **515a** and **515b**. 100/50 GHz interleaver **510** combines (separates out) the single comb of wavelengths to form (from) composite optical connection **505** made up of a comb of wavelengths 50 GHz apart.

In reference to FIG. 4, primary terminal **210** is shown to be composed of a coarse mux **268**, a coarse demux **267**, a fine mux **266**, and a fine demux **265**. The fine demux **265** and fine mux **266** coincide with the preferred embodiment in FIG. 7 of the combination of 100/50 GHz interleavers **510**, 200/100 GHz interleavers **520a-b**, and 400/200 GHz interleavers **530a-d**. The coarse demux **267** and coarse mux **268** coincide with the preferred embodiment in FIG. 7 of 400 GHz filters **540a-h**. The coarse mux **288** and coarse demux **287** in the extension terminals of FIG. 5 and coarse mux **298** and coarse demux **297** of FIG. 6 also coincide with 40 GHz filters **540a-h**. Optical connection **505**, 100/50 fiber connections **515a-d**,

200/100 fiber connections **525a-c**, and fiber connections **535a-h** may function as simple fiber jumpers or optical amplifiers or optical attenuators or some combination thereof to achieve required fiber distances between the various stages of a distributed terminal.

FIG. **8** indicates an alternate embodiment of a mux and demux structure. Mux/demux **600** comprises two submuxs **650a** and demuxs **650b**. Because mux/demux **600** comprises two submux **650a** and demux **650b** pairs, mux/demux **600** is capable of taking  $8 \times N$  optical signals (10 are shown in FIG. **8**) at different wavelengths and combining them onto one output/input connection **605**. Because submux **650a** and demux **650b** are capable of taking four times  $N$  optical signals at different wavelengths and combining them onto one 2000 GHz fiber connection **615a** and **615b**, the architecture is scaleable up or down in the number of wavelengths. For example, a 4000 GHz Band combiner may be placed in conjunction with two mux/demuxes to form a  $16 \times N$  (10) multiplexer unit.

The function of an optical band splitter/combiner is to split/combine a specified band of optical wavelengths consisting of tightly spaced optical wavelengths of typical separation 50 GHz or 25 GHz into or out of two coarse bands of such wavelengths. Specific band splitters or band combiner device implementation are well known in the art and not described further. Band filtering devices can be obtained from, for example, Oplink Corporation model number CR000001111.

In the A-Z direction, signals enter mux/demux **600** through a set of fine 50 GHz filters **640a-h**, known in the art. 50 GHz filters **640a-h** may also be 25 GHz filters also known in the art. Two examples of fine 50 GHz filters **640** are the arrayed waveguide filters and layered dielectric optical filters available as, for example, JDS Uniphase model numbers AWG5NBUC003T and DWM-5F8DSXXX2, respectively.

Starting with fine 50 Hz filter **640a** and **640b**, the  $N(10)$  optical signals are muxed together into a band of wavelengths contained within about 500 GHz and transmitted to 500 GHz band combiner **630a** via 500 GHz fiber connections **635a** and **635b**. Similarly, fine 56 Hz filter pairs **640c** and **640d**, **640e** and **640f** and **640g** and **640h** mux  $N(10)$  optical signals together and transmit the muxed signals to 500 GHz band combiners **630b**, **630c** and **630d** respectively via 500 GHz fiber connections **635c-h** respectively. 500 GHz band combiner **630a** combines the optical signals from filters **640a** and **640b** into a single broader band of wavelengths contained within about 1000 GHz. Similarly, 500 GHz band combiners **630b-d** combine received optical signals into a single broader band of wavelengths.

The single broader band of wavelengths from extension band combiners **630a** and **630b** are transmitted to 1000 GHz band combiner **620a** via 1000 GHz fiber connections **625a** and **625b**. 1000 GHz band combiner **620a** combines the signals from 500 GHz band combiners **630a** and **630b** into a single band of wavelengths contained within about 2000 GHz. Similarly, 1000 GHz band combiner **620b** combines the wavelengths transmitted from 500 GHz band combiners **630c** and **630d** via 1000 GHz fiber connection **625c** and **625d** into a single band of wavelengths. Each 1000 GHz band combiner **620a** and **620b** transmits the single band of wavelengths to 2000 GHz combiner **610** via 2000 GHz fiber connections **615a** and **615b**. 2000 GHz combiner **610** combines the received single band of wavelengths into a composite signal band contained within about 4000 GHz. The composite signal band is transmitted on output/input connection **605**.

In the Z-A direction, 2000 GHz combiner **610** receives a composite signal band contained within about 4000 GHz on

output/input connection **605**. Because a combiner for signals in the A-Z direction can also be a splitter for signals in the Z-A direction, the term combiner will be used to describe both a combiner and a splitter. 2000 GHz combiner **610** splits the composite signal into two single band of wavelengths contained within about 2000 GHz. The bands of wavelengths within 2000 GHz are transmitted to 1000 GHz band combiners **620a** and **620b** via 2000 GHz fiber connections **615a** and **615b**. 1000 GHz combiners **620a** and **620b** each separate the single band of wavelengths within 2000 GHz into two single band of wavelengths within about 1000 GHz. The single band of wavelengths within 1000 GHz is transmitted from 1000 GHz combiners **620a** and **620b** to 500 GHz band combiners **630a-d** via 1000 GHz fiber connections **625a-d**. 500 GHz band combiners **630a-d** each split the single band of wavelengths contained within about 1000 GHz into a single band of wavelengths contained within about 500 GHz. The single band of wavelengths contained within 500 GHz is transmitted from 500 GHz band combiners **630a-d** to fine 50 Hz filters **640a-h** via 500 GHz fiber connections **635a-h**. Fine 50 Hz filters **640a-d** demux the single band of wavelengths within 500 GHz into  $N(10)$  bands of wavelengths wherein the  $N(10)$  wavelengths are transmitted out of mux/demux **600**.

The fine filter function performed by 50 Hz filters **640a-h** and the coarse filtering functions performed by the combination of 2000 GHz combiner **610**, 1000 GHz combiners **620a** and **620b**, and 500 GHz band combiners **630a-d** can be separated. The coarse and fine filtering functions are reversed in the hierarchy of the interleaver based mux **500**. Also, output/input connection **605**, 2000 GHz fiber connection **615a** and **615b**, 1000 GHz fiber connection **625a-h**, and 500 GHz fiber connection **635a-h** may function as simple fiber jumpers, optical amplifiers, optical attenuators, or some combination thereof to achieve required fiber distances between the various stages of primary terminal **210**.

A second alternative embodiment of the multiplexing and demultiplexing function of the present invention is indicated in FIGS. **9a**, **9b**, **10a** and **10b**. The embodiment depicts a means of implementing a wavelength tunable system with primary terminals. Beginning with FIGS. **9a** and **9b** tunable demux **700** is composed primarily of first optical splitter **710**, second optical splitter **720a** and **720b**, and third optical splitter **730a-h**. Third optical splitter **730a-h** is operationally connected to tunable filters **740** via tunable filter fiber connection **731**.

In the Z-A direction, first optical splitter **710** receives a composite signal band contained within about 4000 GHz on tunable input connection **705**. The embodiment shown is one way of constructing a "tree" whereby a single band of wavelengths transmitted on tunable input connection **705** is demuxed so as separate out groups of wavelengths. The exact nature and combining ratio is not essential. First optical splitter **710** splits the composite signal on tunable input connection **705** into two single bands of wavelengths contained within about 2000 GHz. The bands of wavelengths within 2000 GHz are transmitted to second optical splitters **720a** and **720b** via first splitter fiber connections **715a** and **715b**. Second optical splitters **720a** and **720b** each separate the single bands of wavelengths within 2000 GHz into two single band of wavelengths within about 1000 GHz. The single bands of wavelengths within 1000 GHz are transmitted from second optical splitters **720a** and **720b** to third optical splitters **730a-h** via second splitter fiber connection **725a-h**. Third optical splitters **730a-h** each split the single band of wavelengths contained within about 1000 GHz into a single band of wavelengths contained within about 500 GHz. The single band of wavelengths contained within 500 GHz is transmitted from

third optical splitters **730a-h** to tunable filters **740a-x** via tunable filter fiber connections **731**.

While the order could be greater, in the preferred embodiment, tunable filters **740a-x** operate as narrow spectral width bandpass filters with a passband in the order of two and one-half to three times the bandwidth of the carrier frequency; for example, 30 GHz or more for a 10 GHz optical signal. Tunable filters **740a-x** are tuned to pass any one of the signals appearing at the outputs of third optical splitters **730a-h**. Optical splitters are known in the art, an example being JDS Uniphase model number NEM-221003119. Tunable optical filters are also known in the art, examples being JDS Uniphase model number VCF050 or NORTEL model number MT-15-025. Tunable input connection **705**, first splitter fiber connections **715a** and **715b**, and second splitter fiber connection **725a-h** may function as simple fiber jumpers or optical amplifiers or optical attenuators or some combination thereof to achieve required fiber distances between the various stages of a distributed terminal.

With reference to FIGS. **10a** and **10b**, tunable mux **701** is composed of first optical combiner **711**, second optical combiner **760a** and **760b**, and third optical combiner **770a-h**. Third optical combiner **770a-h** is operationally connected to tunable lasers **780a-x**. Tunable lasers **780a-x** may be narrowly tunable around 200 GHz or broadly tunable, for example, over the entire C or L band of Erbium-doped fiber amplifiers, the spectral width being of the order of 4000 GHz. The laser components may have an optical output power on the order of 20 mW, wavelength stability on the order of 2.5 GHz or better, side-mode suppression ratio on the order of 35 dB, and relative intensity noise (RIN) on the order of -140 dB. Optical combiners are known in the art, an example being JDS Uniphase model number NEM-221003119. Tunable lasers are known in the art, one example, JDS Uniphase CQF310120819365.

In the Z-A direction, tunable lasers **780a-x** receives a composite signal. The exact nature and combing ratio is not essential, the embodiment shown is one way of constructing a "tree" whereby one or more optical signals generated by one or more different tunable lasers are wavelength muxed so as to appear at output fiber connection **706** as a single band of wavelengths.

Tunable lasers **780** receive a band of wavelengths. The wavelengths are tuned and transmitted to third optical combiner **770a-h** via tunable laser fiber connection **775**. Third optical combiner **770a-h** muxes the received signal from tunable lasers **780a-x** into a single band of wavelengths within 500 GHz. The single band of wavelengths within 500 GHz is transmitted to extension optical combiner **760a** and **760b** via second optical fiber connections **726a-h**. Second optical combiners **760a** and **760b** mux the received single band of wavelengths within 500 GHz into a single band of wavelengths contained within about 1000 GHz. The single band of wavelengths contained within about 1000 GHz is transmitted to first optical combiner **711** via first fiber connections **716a** and **716b**. Primary optical combiner **711** muxes the received single band of wavelengths within 1000 GHz into a single band of wavelengths within about 2000 GHz. The single band of wavelengths within about 2000 GHz is transmitted over output fiber connection **706**.

Output fiber connections **706**, first fiber connections **716a** and **716b**, second fiber connections **726a-h**, and tunable laser fiber connection **775** may function as simple fiber jumpers or optical amplifiers or optical attenuators or some combination thereof to achieve required fiber distances between the various stages of a distributed terminal.

Valid and useful multiplexer and demultiplexer designs can be constructed with combinations of parts shown in FIGS. **7**, **8**, **9a**, **9b**, **10a** and **10b**. Fine mux/demux **640a-b** from FIG. **8** can individually replace blocks **740a-x** as shown in FIGS. **9a** and **9b** or blocks **780a-x** as shown in FIGS. **10a** and **10b** to form splitter/combiner based fixed filters. This alternate arrangement is advantageous because the cost of components would scale with the deployed bandwidth. Likewise, tunable components **740a-x** from FIGS. **9a** and **9b** and **780a-x** from FIGS. **10a** and **10b** can individually replace the fixed filters **640a-h** in FIG. **8** to form banded DWDM based tunable filters. Another advantageous embodiment is that of replacing coarse mux/demux filters **540a-h** in FIG. **7** with the tunable filter components **780a-x** from FIGS. **9a** and **9b** and **740a-x** from FIGS. **10a** and **10b** to form a mux and demux, respectively.

FIGS. **11** and **12** show different shelf connection configurations of the preferred embodiment that result from integrating the sub-systems of FIGS. **4-7** into a distributed terminal system. Each numbered block in FIGS. **11** and **12** is a self-contained shelf within the optical transmission system: the master terminal shelf **910** embodies the primary terminal **210**, the slave shelves **920a-b** embody the type one extension terminal **220**; and the dual slaves shelf **925a-b** embody two type two extension terminals **225** in one unit. In the preferred embodiment, eight optical mux groups are made up of 10 optical signal-carrying wavelengths.

FIG. **11** depicts a star configuration **900**, whereby the submuxs are both contained within the master terminal shelf **910** along with one local 400 GHz filter. The shelves **910** and **920a-c** are interconnected using fiber jumpers **916**, **914** and **912**. Dual slave shelves **925a-b** are interconnected using fiber jumpers **902**, **904**, **906** and **908**.

FIG. **12a** depicts a second configuration **940** whereby two master shelves **911a** and **911b** are utilized to distribute the optical mux groups. Shelf **911a**, is similar in function to primary terminal **210**, and a 100/506 GHz interleaver, submux, and a 400 GHz filter. Shelf **911b**, which is also similar in function to primary terminal **210**, contains submuxs and a 400 GHz filter. The interconnection between master shelves **911a** and **911b** is accomplished by fiber interconnection **932** which is a 100/50 fiber connection. The configurations **940** and **960** service 8 optical mux groups or up to 80 optical signal wavelengths in six shelves. Line **941** is an optical input/output connection. Slave shelves **920a** and **920b** and dual slave shelves **925a** and **925b** contain the same equipment as described in relation to FIG. **11**. Dual slave shelves **925a** and **925b** are coupled to master shelf via dual slave-to-master connections **918**, **922** and **924**. Slave shelves **920a** and **920b** are coupled to master shelf **911b** via slave-to-master connections **926** and **928**. Dual slave-to-master connections **918** and **922** may be as long as about 5 km in the preferred embodiment. Slave-to-master connections **926** and **928** may be as long as about 100 km without additional optical amplifiers.

FIG. **12b** depicts a third configuration **960** similar to configuration **940** but utilizing only dual slave shelves **925a-c** attached to the master shelves **911a** and **911b**. Configuration **960** achieves the highest system density of the configurations of the preferred embodiment. Two master shelves, **911a** and **911b**, and three dual slave shelves **925a-c** can be used to service all 8 optical mux groups or up to 80 optical signal wavelengths in less than two standard 19 or 23 inch wide seven foot equipment racks. Master shelf **911a** is connected to master shelf **911b** by connection **933**. Master shelf a and b contain the same components as described in relation to FIG. **12a**. Master shelf a is connected to dual slave shelf **925a** by jumpers **923** and **925**. Master shelf **911a** is connected to dual



slave shelf 925c by jumper 919. Master shelf 911b is connected to dual slave shelf 925b by jumpers 929 and 931. Master shelf 911b is connected to dual slave shelf 925c through jumper 927.

Dual slave shelves 925a, b and c contain the same equipment as described in FIG. 12a. The fiber shelf interconnections 919, 923, 927, 925, 929 and 931 may be as long as about 5 km in the preferred embodiment while the master-to-master fiber connection 933 may be on the order of 100 km (without additional optical amplifiers).

Although the invention has been described with reference to one or more preferred embodiments, this description is not to be construed in a limiting sense. There is modification of the disclosed embodiments, as well as alternative embodiments of this invention, which will be apparent to persons of ordinary skill in the art, and the invention shall be viewed as limited only by reference to the following claims.

The invention claimed is:

**[1.** An interdomain optical transport system comprising:  
 a first transponder photonicallly connected to a first end user device, wherein the first transponder is configured to receive a first photonic signal from the first end user device and to convert the first photonic signal to a long range photonic signal for transmission over a long haul network;  
 a first coarse optical filter connected to the first transponder;  
 a first fine optical filter connected to the first coarse optical filter;  
 a second transponder photonicallly connected to the first transponder via the long haul network and a metro network, wherein the second transponder is further connected to a second end user device,  
 wherein the second transponder is configured to receive the long range photonic signal, to convert the long range photonic signal to a second photonic signal, and to transmit the second photonic signal to the second end user device, and  
 wherein communication between the first and second end user devices is accomplished without translation between a short range signal format and a long range signal format.]

**[2.** The interdomain optical transport system of claim 1, wherein:  
 the first transponder is part of a first primary terminal; and  
 the second transponder is part of a second primary terminal.]

**[3.** The interdomain optical transport system of claim 1, wherein:  
 the first transponder is part of a primary terminal; and  
 the second transponder is part of an extension terminal.]

**[4.** The interdomain optical transport system of claim 3, wherein the second transponder is a bidirectional transponder, and

wherein the interdomain optical transport system further comprises an optical filter that is connected to the second transponder.]

**[5.** The interdomain optical transport system of claim 4, wherein the optical filter includes a banded DWDM filter.]

**[6.** The interdomain optical transport system of claim 4, wherein the optical filter is interleaver based.]

**[7.** The interdomain optical transport system of claim 4, wherein the optical filter includes a tunable filter.]

**[8.** The interdomain optical transport system of claim 7, wherein the tunable filter includes a distributed tunable optical multiplexer and a distributed tunable optical demultiplexer.]

**[9.** The interdomain optical transport system of claim 8, wherein the tunable filter includes a splitter.]

**[10.** The interdomain optical transport system of claim 1, wherein at least one of the first coarse optical filter or the first fine optical filter includes an interleaver and a tunable filter.]

**[11.** The interdomain optical transport system of claim 1, wherein at least one of the first coarse optical filter or the first fine optical filter includes a band filter and a DWDM filter.]

**[12.** The interdomain optical transport system of claim 1, wherein at least one of the first coarse optical filter or the first fine optical filter includes a band filter and a tunable filter.]

**[13.** The interdomain optical transport system of claim 1, wherein at least one of the first coarse optical filter or the first fine optical filter includes a tunable filter.]

**[14.** The interdomain optical transport system of claim 13, wherein the tunable filter includes a distributed tunable optical multiplexer and a distributed tunable optical demultiplexer.]

**[15.** The interdomain optical transport system of claim 13, wherein the tunable filter includes a splitter.]

**[16.** The interdomain optical transport system of claim 1, wherein the first transponder is a bidirectional transponder, and

wherein the interdomain optical transport system further comprises an optical amplifier that is connected to the first fine optical filter.]

**[17.** The interdomain optical transport system of claim 1, wherein at least one of the first coarse optical filter or the first fine optical filter includes a banded DWDM filter.]

**[18.** The interdomain optical transport system of claim 1, wherein at least one of the first coarse optical filter or the first fine optical filter includes an interleaver.]

**[19.** The interdomain optical transport system of claim 1, wherein at least one of the first coarse optical filter or the first fine optical filter includes a splitter and a DWDM filter.]

**[20.** The interdomain optical transport system of claim 1, wherein at least one of the first coarse optical filter or the first fine optical filter includes a splitter and a tunable filter.]

**[21.** The interdomain optical transport system of claim 1, wherein at least one of the first coarse optical filter or the first fine optical filter includes an interleaver and a DWDM filter.]

**[22.** The interdomain optical transport system of claim 1, wherein the interdomain optical transport system further comprises:

a second coarse optical filter that is connected to the second transponder;

a second fine optical filter that is connected to the second coarse optical filter; and

an optical amplifier that is connected to the second fine optical filter.]

**[23.** The interdomain optical transport system of claim 22, wherein at least one of the second coarse optical filter or the second fine optical filter is a banded DWDM filter.]

**[24.** The interdomain optical transport system of claim 22, wherein at least one of the second coarse optical filter or the second fine optical filter is interleaver based.]

**[25.** The interdomain optical transport system of claim 22, wherein at least one of the second coarse optical filter or the second fine optical filter includes a tunable filter.]

**[26.** The interdomain optical transport system of claim 25, wherein the tunable filter includes a distributed tunable optical multiplexer and a distributed tunable optical demultiplexer.]

**[27.** The interdomain optical transport system of claim 1, wherein the first transponder is in a first physical configuration adapted to fit in a first equipment rack, and

wherein the second transponder is in a second physical configuration adapted to fit in a second equipment rack.]

[28. The interdomain optical transport system of claim 27, wherein the first and second physical configurations each include at least one master shelf, at least one slave shelf and at least one dual slave shelf.]

[29. The interdomain optical transport system of claim 27, wherein the first and second physical configurations each include at least two master shelves, at least two slave shelves, and at least two dual slave shelves.]

[30. The interdomain optical transport system of claim 27, wherein the first and second physical configurations each include at least two master shelves and at least three dual slave shelves.]

[31. The interdomain optical transport system of claim 1, wherein the first transponder is connected to a third end user device.]

[32. An interdomain optical transport system comprising:

a first extension terminal connected to a first end user device, wherein the first extension terminal is configured to receive a first photonic signal from the first end user device and to translate the first photonic signal into a long range photonic signal;

a first primary terminal connected to the first extension terminal via a metro network, wherein the first primary terminal is configured to receive and retransmit the long range photonic signal;

an optical transmission path connected to the first primary terminal, wherein the optical transmission path includes at least one optical add drop multiplexer, and wherein the optical transmission path is configured to receive and communicate the long range photonic signal;

a second primary terminal connected to the optical transmission path, wherein the second primary terminal is configured to receive and retransmit the long range photonic signal;

a second extension terminal connected to the second primary terminal and to a second end user device, wherein the second extension terminal is configured to receive and translate the long range photonic signal into a second photonic signal and to transmit the second photonic signal to the second end user device, and wherein communication between the first and second end user devices is accomplished without translation between a short range signal format and a long range signal format;

a third primary extension terminal connected to the at least one optical add drop multiplexer; and

a third extension terminal connected to the third primary terminal.]

[33. The interdomain optical transport system of claim 32, wherein the second extension terminal is connected to a third end user device.]

[34. The interdomain optical transport system of claim 32, wherein the first extension terminal is connected to a third end user device.]

[35. The interdomain optical transport system of claim 32, further comprising a fourth extension terminal connected to the first primary terminal.]

[36. The interdomain optical transport system of claim 35, wherein the first and fourth extension terminals are each connected to the first end user device.]

[37. The interdomain optical transport system of claim 32, wherein the first primary terminal is further configured to receive a second long range photonic signal from a fourth extension terminal and to multiplex the second long range photonic signal onto the optical transmission path.]

[38. The interdomain optical transport system of claim 37, wherein the second primary terminal is further configured to demultiplex the second long range photonic signal from the optical transmission path and to transmit the second long range photonic signal to a fourth primary terminal.]

[39. The interdomain optical transport system of claim 32, further comprising a fourth extension terminal and a fifth extension terminal, each connected to the first primary terminal.]

[40. The interdomain optical transport system of claim 39, wherein the fourth and fifth extension terminals are each connected to a third end user device.]

[41. The interdomain optical transport system of claim 32, wherein the optical transmission path includes at least one optical amplifier.]

[42. The interdomain optical transport system of claim 32, wherein the optical transmission path includes a broadcast and select architecture.]

[43. The interdomain optical transport system of claim 32, wherein the third extension terminal is connected to a third end user device.]

[44. The interdomain optical transport system of claim 32, wherein the first primary terminal includes;

a bidirectional transponder;  
an optical filter connected to the bidirectional transponder;  
and  
an optical amplifier connected to the optical filter.]

[45. The interdomain optical transport system of claim 44, wherein the optical filter is a banded DWDM filter.]

[46. The interdomain optical transport system of claim 44, wherein the optical filter is interleaver based.]

[47. The interdomain optical transport system of claim 44, wherein the optical filter includes a tunable filter.]

[48. The interdomain optical transport system of claim 47, wherein the tunable filter includes a distributed tunable optical multiplexer and a distributed tunable optical demultiplexer.]

[49. The interdomain optical transport system of claim 32, wherein the second primary terminal includes:

a bidirectional transponder; and  
an optical filter connected to the bidirectional transponder.]

[50. The interdomain optical transport system of claim 49, wherein the optical filter includes a banded DWDM filter.]

[51. The interdomain optical transport system of claim 49, wherein the optical filter includes a splitter and a DWDM filter.]

[52. The interdomain optical transport system of claim 49, wherein the optical filter includes a splitter and a tunable filter.]

[53. The interdomain optical transport system of claim 49, wherein the optical filter includes an interleaver and a DWDM filter.]

[54. The interdomain optical transport system of claim 49, wherein the optical filter includes an interleaver and a tuner.]

[55. The interdomain optical transport system of claim 49, wherein the optical filter includes a band filter and a DWDM filter.]

[56. The interdomain optical transport system of claim 49, wherein the optical filter includes a band filter and a tunable filter.]

[57. The interdomain optical transport system of claim 49, wherein the optical filter is interleaver based.]

[58. The interdomain optical transport system of claim 49, wherein the optical filter includes a tunable filter.]

[59. The interdomain optical transport system of claim 58, wherein the tunable filter includes at least one splitter.]

**[60.** The interdomain optical transport system of claim **58**, wherein the tunable filter includes a distributed tunable optical multiplexer and a distributed tunable optical demultiplexer.]

**[61.** The interdomain optical transport system of claim **32**, wherein the first primary terminal includes:

a bidirectional transponder;

a coarse optical filter connected to the bidirectional transponder;

a fine optical filter connected to the coarse optical filter; and an optical amplifier connected to the fine optical filter.]

**[62.** The interdomain optical transport system of claim **61**, wherein at least one of the coarse optical filter or the fine optical filter includes a banded DWDM filter.]

**[63.** The interdomain optical transport system of claim **61**, wherein at least one of the coarse optical filter or the fine optical filter is interleaver based.]

**[64.** The interdomain optical transport system of claim **61**, wherein at least one of the coarse optical filter or the fine optical filter includes a tunable filter.]

**[65.** The interdomain optical transport system of claim **64**, wherein the tunable filter includes a distributed tunable optical multiplexer and a distributed tunable optical demultiplexer.]

**[66.** A method for transporting optical signals over an interdomain optical transport system, the method comprising:

receiving a first optical signal from a first end user device at a first extension terminal, the first extension terminal including a first coarse multiplexer and a first coarse demultiplexer;

converting the first optical signal to a first long range optical signal for transmission over a long haul network;

transmitting the first long range optical signal to a second extension terminal via the long haul network and a metro network, the second extension terminal including a second coarse multiplexer and a second coarse demultiplexer;

converting the first long range optical signal to a second optical signal; and

transmitting the second optical signal to a second end user device,

wherein communication between the first and second end user devices is accomplished without translation between a short range signal format and a long range signal format.]

**[67.** The method of claim **66**, wherein the short range signal format accommodates propagation distances equal to or less than about 80 kilometers, and wherein the long range signal format accommodates propagation distances greater than about 80 kilometers.]

**[68.** The method of claim **66**, further comprising reducing an operational cost associated with the interdomain optical transport system by communicating between the first and second end user devices without translation between the short range and long range signal formats.]

**[69.** The method of claim **68**, further comprising increasing a profit from the communication between the first and second end user devices by reducing the operational cost.]

**[70.** The method of claim **66**, wherein the first and second extension terminals include a first transponder and a second transponder, respectively.]

**[71.** The method of claim **66** further comprising:

receiving a third optical signal from a third end user device at the first extension terminal;

converting the third optical signal to a second long range optical signal;

multiplexing the first and second long range optical signals; and

transmitting the multiplexed first and second long range optical signals to the second extension terminal via the metro network.]

**[72.** The method of claim **71** further comprising: demultiplexing the multiplexed first and second long range optical signals;

converting the second long range optical signal to a fourth optical signal; and

transmitting the fourth optical signal to a fourth end user device.]

**[73.** The method of claim **66**, wherein the first and second optical signals are suitable for use by the first and second end user devices, respectively.]

**[74.** An interdomain optical transport system comprising: a first extension terminal connected to a first end user device, wherein the first extension terminal is configured to receive a first photonic signal from the first end user device and to translate the first photonic signal into a long range photonic signal;

a second extension terminal connected to a second end user device;

a third extension terminal connected to the second end user device;

a first primary terminal connected to the first, second and third extension terminals via at least one metro network, wherein the first primary terminal is configured to receive and retransmit the long range photonic signal;

an optical transmission path connected to the first primary terminal, wherein the optical transmission path is configured to receive and communicate the long range photonic signal;

a second primary terminal connected to the optical transmission path, wherein the second primary terminal is configured to receive and retransmit the long range photonic signal; and

a fourth extension terminal connected to the second primary terminal and to a third end user device, wherein the fourth extension terminal is configured to receive and translate the long range photonic signal into a second photonic signal and to transmit the second photonic signal to the third end user device, and wherein communication between the first and third end user devices is accomplished without translation between a short range signal format and a long range signal format.]

**[75.** The interdomain optical transport system of claim **74**, wherein the first primary terminal includes:

a bidirectional transponder;

an optical filter connected to the bidirectional transponder; and

an optical amplifier connected to the optical filter.]

**[76.** The interdomain optical transport system of claim **75**, wherein the optical filter is a banded DWDM filter.]

**[77.** The interdomain optical transport system of claim **75**, wherein the optical filter is interleaver based.]

**[78.** The interdomain optical transport system of claim **75**, wherein the optical filter includes a tunable filter.]

**[79.** The interdomain optical transport system of claim **74**, wherein the first primary terminal includes:

a bidirectional transponder;

a coarse optical filter connected to the bidirectional transponder;

a fine optical filter connected to the coarse optical filter; and

an optical amplifier connected to the fine optical filter.]

**[80.** The interdomain optical transport system of claim **74**, wherein the second primary terminal includes:

25

a bidirectional transponder;  
 an optical filter connected to the bidirectional transponder;  
 and  
 an optical amplifier connected to the optical filter.]

[81. The interdomain optical transport system of claim 80,  
 wherein the optical filter is a banded DWDM filter.]

[82. The interdomain optical transport system of claim 80,  
 wherein the optical filter is interleaver based.]

[83. The interdomain optical transport system of claim 80,  
 wherein the optical filter includes a tunable filter.]

[84. The interdomain optical transport system of claim 74,  
 wherein the second primary terminal includes:  
 a bidirectional transponder;  
 a coarse optical filter connected to the bidirectional transponder;  
 a fine optical filter connected to the coarse optical filter; and  
 an optical amplifier connected to the fine optical filter.]

[85. An interdomain optical transport system comprising:  
 a first extension terminal connected to a first end user device,  
 wherein the first extension terminal is configured to receive a first photonic signal from the first end user device and to translate the first photonic signal into a long range photonic signal;  
 a second extension terminal connected to the first end user device;  
 a first primary terminal connected to the first and second extension terminals via at least one metro network,  
 wherein the first primary terminal is configured to receive and retransmit the long range photonic signal;  
 an optical transmission path connected to the first primary terminal,  
 wherein the optical transmission path is configured to receive and communicate the long range photonic signal;  
 a second primary terminal connected to the optical transmission path,  
 wherein the second primary terminal is configured to receive and retransmit the long range photonic signal; and  
 a third extension terminal connected to the second primary terminal and to a second end user device,  
 wherein the third extension terminal is configured to receive and translate the long range photonic signal into a second photonic signal and to transmit the second photonic signal to the second end user device,  
 and wherein communication between the first and second end user devices is accomplished without translation between a short range signal format and a long range signal format.]

[86. The interdomain optical transport system of claim 85,  
 wherein the first primary terminal includes:  
 a bidirectional transponder;  
 an optical filter connected to the bidirectional transponder;  
 and  
 an optical amplifier connected to the optical filter.]

[87. The interdomain optical transport system of claim 86,  
 wherein the optical filter is a banded DWDM filter.]

[88. The interdomain optical transport system of claim 86,  
 wherein the optical filter is interleaver based.]

[89. The interdomain optical transport system of claim 86,  
 wherein the optical filter includes a tunable filter.]

[90. The interdomain optical transport system of claim 85,  
 wherein the first primary terminal includes:  
 a bidirectional transponder;  
 a coarse optical filter connected to the bidirectional transponder;  
 a fine optical filter connected to the coarse optical filter; and  
 an optical amplifier connected to the fine optical filter.]

26

[91. The interdomain optical transport system of claim 85,  
 wherein the second primary terminal includes:  
 a bidirectional transponder;  
 an optical filter connected to the bidirectional transponder;  
 and  
 an optical amplifier connected to the optical filter.]

[92. The interdomain optical transport system of claim 91,  
 wherein the optical filter is a banded DWDM filter.]

[93. The interdomain optical transport system of claim 91,  
 wherein the optical filter is interleaver based.]

[94. The interdomain optical transport system of claim 91,  
 wherein the optical filter includes a tunable filter.]

[95. The interdomain optical transport system of claim 85,  
 wherein the second primary terminal includes:  
 a bidirectional transponder;  
 a coarse optical filter connected to the bidirectional transponder;  
 a fine optical filter connected to the coarse optical filter; and  
 an optical amplifier connected to the fine optical filter.]

96. A method for transporting optical signals from a first terminal to a second terminal, the method comprising:  
 receiving a first optical signal at the first terminal, wherein the first terminal includes a coarse multiplexer and a coarse demultiplexer, wherein the first optical signal is suitable for use by a first end user device;  
 deriving a second optical signal suitable for long haul transmission from the first optical signal; and  
 transmitting the second optical signal from the first terminal to the second terminal, wherein the second terminal includes a coarse multiplexer and a coarse demultiplexer, wherein the second terminal is configured to transmit a third optical signal suitable for use by a second end user device, wherein the third optical signal is derived from the second optical signal;  
 wherein the first optical signal is received, the second optical signal is derived, and the third optical signal is transmitted without translation of the first and third optical signals between a short range signal format and a long range signal format.

97. The method of claim 96, wherein the short range signal format accommodates propagation distances equal to or less than about 80 kilometers, and wherein the long range signal format accommodates propagation distances greater than about 80 kilometers.

98. The method of claim 96, wherein the deriving comprises deriving the second optical signal by a transponder.

99. The method of claim 96, further comprising:  
 receiving, at the first terminal, a fourth optical signal; and  
 deriving a fifth optical signal suitable for long haul transmission from the fourth optical signal;  
 multiplexing the second optical signal and the fifth optical signal;  
 wherein transmitting the second optical signal comprises transmitting the multiplexed second and fifth optical signals.

100. The method of claim 99, wherein the second terminal is configured to:  
 demultiplex the multiplexed second and fifth optical signals; and  
 transmit a sixth optical signal, wherein the sixth optical signal is derived from the fifth optical signal.

101. The method of claim 100, wherein the sixth optical signal is suitable for use by a third end user device.

102. An optical transport terminal comprising:  
 a transponder configured to receive a first optical signal and to create a second optical signal suitable for long haul transmission, the second optical signal being

derived from the first optical signal, wherein the transponder is configured to receive the first optical signal from an end user device;  
 a coarse optical filter configured to filter the second optical signal;  
 a fine optical filter configured to filter the second optical signal; and  
 a transmitter configured to transmit the second optical signal from the optical transport terminal to a second terminal via a long haul network and a metro network, wherein the second terminal includes a coarse multiplexer and a coarse demultiplexer, wherein the second terminal is configured to transmit a third optical signal suitable for use by a second end user device;  
 wherein the optical transport terminal is configured to receive the first optical signal and the second terminal is configured to transmit the third optical signal without translation of the first and third optical signals between a short range signal format and a long range signal format.

103. The optical transport terminal of claim 102, wherein the short range signal format accommodates propagation distances equal to or less than about 80 kilometers, and wherein the long range signal format accommodates propagation distances greater than about 80 kilometers.

104. The optical transport terminal of claim 102, further comprising an optical amplifier that is connected to the fine optical filter.

105. The optical transport terminal of claim 102, wherein at least one of the coarse optical filter or the fine optical filter comprises at least one of the group consisting of: a banded dense wavelength division multiplexing (DWDM) filter, an interleaver, a splitter, a DWDM filter, a tunable filter, a distributed tunable optical multiplexer, a distributed tunable optical demultiplexer.

106. The optical transport terminal of claim 102, wherein the optical transport terminal is in a physical configuration configured to fit in an equipment rack.

107. The optical transport terminal of claim 106, wherein the physical configuration includes at least one master shelf, at least one slave shelf, and at least one dual slave shelf.

108. The optical transport terminal of claim 106, wherein the physical configuration includes at least two master shelves, at least two slave shelves, and at least two dual slave shelves.

109. The optical transport terminal of claim 106, wherein the physical configuration includes at least two master shelves and at least three dual slave shelves.

110. A method for transporting optical signals from a first terminal to a second terminal, wherein the first and second terminals each include a coarse multiplexer and a coarse demultiplexer, the method comprising:

receiving a first optical signal at the first terminal, wherein the first optical signal is suitable for use by a first end user device;

deriving a second optical signal suitable for long haul transmission from the first optical signal;

multiplexing the second optical signal with at least one other optical signal to form an output optical signal; and

transmitting the output optical signal from the first terminal to the second terminal, wherein the second terminal is configured to transmit a third optical signal suitable for use by a second end user device, wherein the third optical signal is derived from the second optical signal;

wherein the first optical signal is received, the second optical signal is multiplexed, and the output optical signal is transmitted, and the third optical signal is transmitted without translation of the first, second, and third optical signals between a short range signal format and a long range signal format.

111. The method of claim 110, wherein the short range signal format accommodates propagation distances equal to or less than about 80 kilometers, and wherein the long range signal format accommodates propagation distances greater than about 80 kilometers.

112. The method of claim 110, wherein the deriving comprises deriving the second optical signal by a transponder.

113. The method of claim 110, wherein the first optical signal is suitable for use by a first end user device and wherein the third optical signal is suitable for use by a second end user device.

114. The method of claim 110, further comprising: receiving, at the first terminal, a fourth optical signal; and deriving a fifth optical signal suitable for long haul transmission from the fourth optical signal;

wherein multiplexing the second optical signal comprises multiplexing the second optical signal and the fifth optical signal to form the output optical signal.

115. The method of claim 114, wherein the second terminal is configured to:

demultiplex the multiplexed second and fifth optical signals; and

transmit a sixth optical signal, wherein the sixth optical signal is derived from the fifth optical signal, wherein the sixth optical signal is suitable for use by a third end user device.

\* \* \* \* \*