

US00RE45071E

(19) **United States**  
(12) **Reissued Patent**  
**Hong et al.**

(10) **Patent Number:** **US RE45,071 E**  
(45) **Date of Reissued Patent:** **Aug. 12, 2014**

(54) **SEMICONDUCTOR LASER DIODE AND METHOD OF MANUFACTURING THE SAME**

5,615,224	A *	3/1997	Cohen	372/36
6,044,098	A *	3/2000	Sun	372/46.013
6,873,638	B2	3/2005	Haase et al.	
2002/0034204	A1 *	3/2002	Iwamoto et al.	372/46
2002/0114367	A1 *	8/2002	Stintz et al.	372/45
2003/0007535	A1 *	1/2003	Haase et al.	372/50
2003/0165169	A1 *	9/2003	Nomoto et al.	372/46

(75) Inventors: **Sung Ui Hong**, Seongnam-si (KR); **Jin Hong Lee**, Gwangju-si (KR); **Jin Soo Kim**, Jeonju-si (KR); **Ho Sang Kwack**, Paju-si (KR); **Dae Kon Oh**, Daejeon-si (KR)

**FOREIGN PATENT DOCUMENTS**

(73) Assignee: **Electronics and Telecommunications Research Institute**, Daejeon (KR)

KR	10-0159015	8/1998
KR	0159015	8/1998
KR	10-034331	6/2002
KR	10-0343311	6/2002

(21) Appl. No.: **13/070,906**

\* cited by examiner

(22) Filed: **Mar. 24, 2011**

*Primary Examiner* — Xinning Niu

**Related U.S. Patent Documents**

(74) *Attorney, Agent, or Firm* — NSIP Law

Reissue of:

(64) Patent No.: **7,508,857**  
Issued: **Mar. 24, 2009**  
Appl. No.: **11/265,712**  
Filed: **Nov. 2, 2005**

(57) **ABSTRACT**

(30) **Foreign Application Priority Data**

Dec. 14, 2004 (KR) ..... 10-2004-0105818  
May 24, 2005 (KR) ..... 10-2005-0043466

Provided are a semiconductor laser diode and a method of manufacturing the same. The semiconductor laser diode includes a lower cladding layer disposed on a substrate; a ridge including an optical waveguide layer, an active layer, an upper cladding layer, and an ohmic contact layer, which are sequentially stacked on the lower cladding layer, and having a predetermined width, which is obtained by performing a channel etching process on both sides of the ridge; an oxide layer disposed on surfaces of the upper and lower cladding layer to control the width of the ridge; a dielectric layer disposed on left and right channels of the ridge; an upper electrode layer disposed on the entire surface of the resultant structure to enclose the ridge and the dielectric layer; and a lower electrode layer disposed on a bottom surface of the substrate. The method is simpler than a conventional process of manufacturing a semiconductor laser diode. Also, by controlling a wet oxidation time, the width of a ridge can be freely controlled and an ohmic contact layer can be automatically formed.

(51) **Int. Cl.**  
**H01S 5/22** (2006.01)

(52) **U.S. Cl.**  
USPC ..... **372/46.01**; 372/43.01; 372/45.01;  
372/46.013

(58) **Field of Classification Search**  
USPC ..... 372/46.01  
See application file for complete search history.

(56) **References Cited**

**U.S. PATENT DOCUMENTS**

4,607,369	A *	8/1986	Niina et al.	372/46.01
5,521,935	A *	5/1996	Irikawa	372/45.011

**36 Claims, 2 Drawing Sheets**

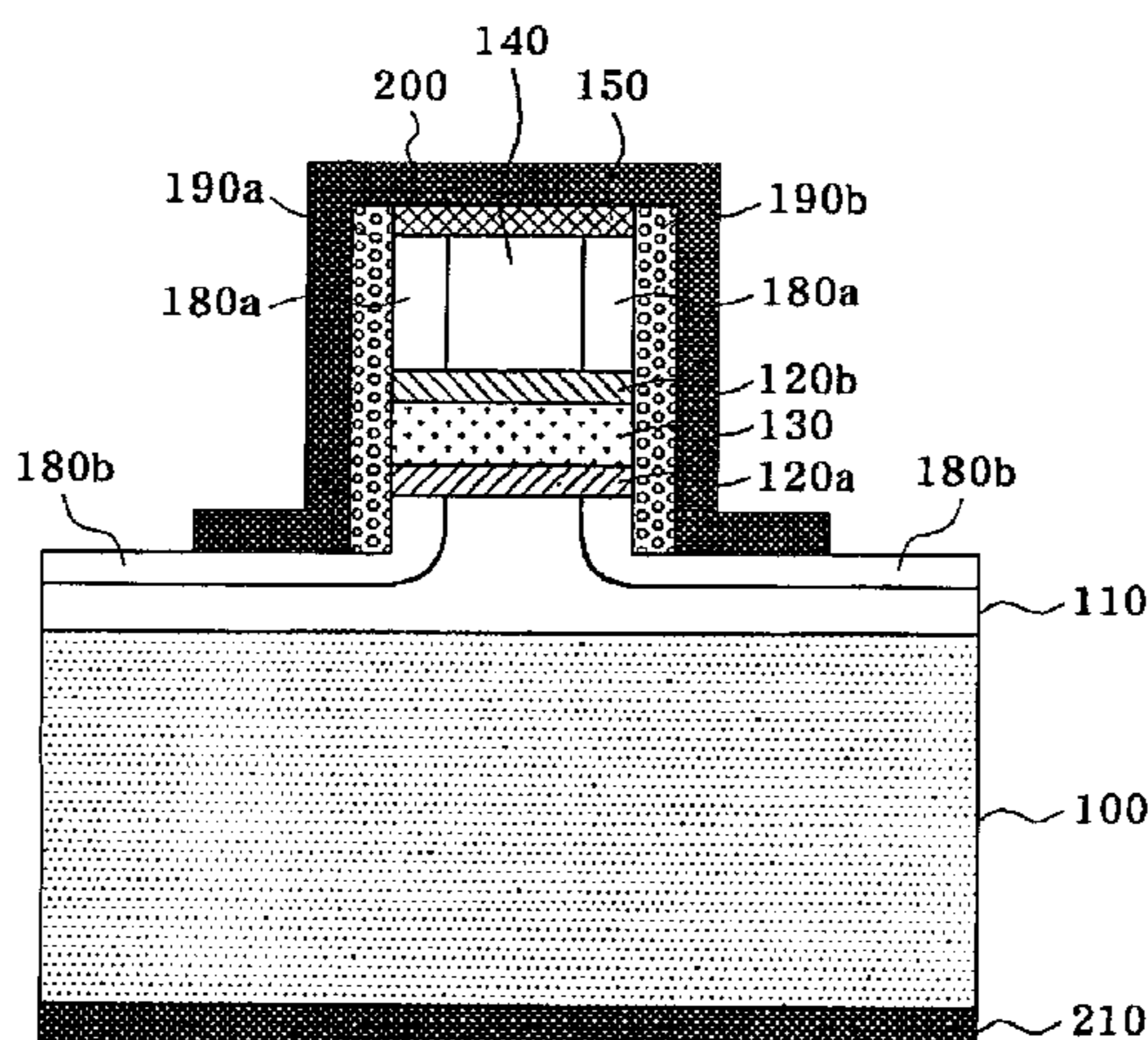

FIG. 1A

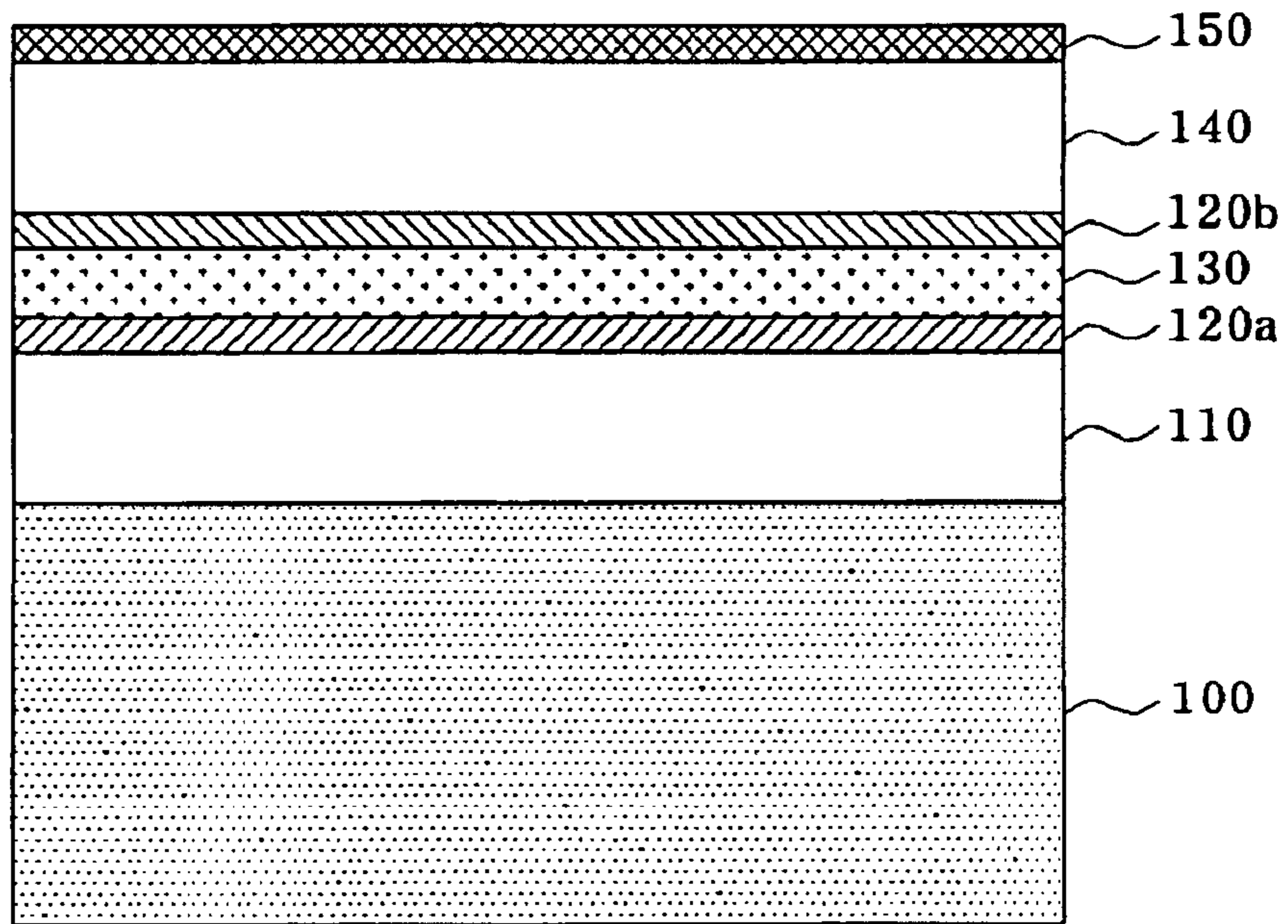

FIG. 1B

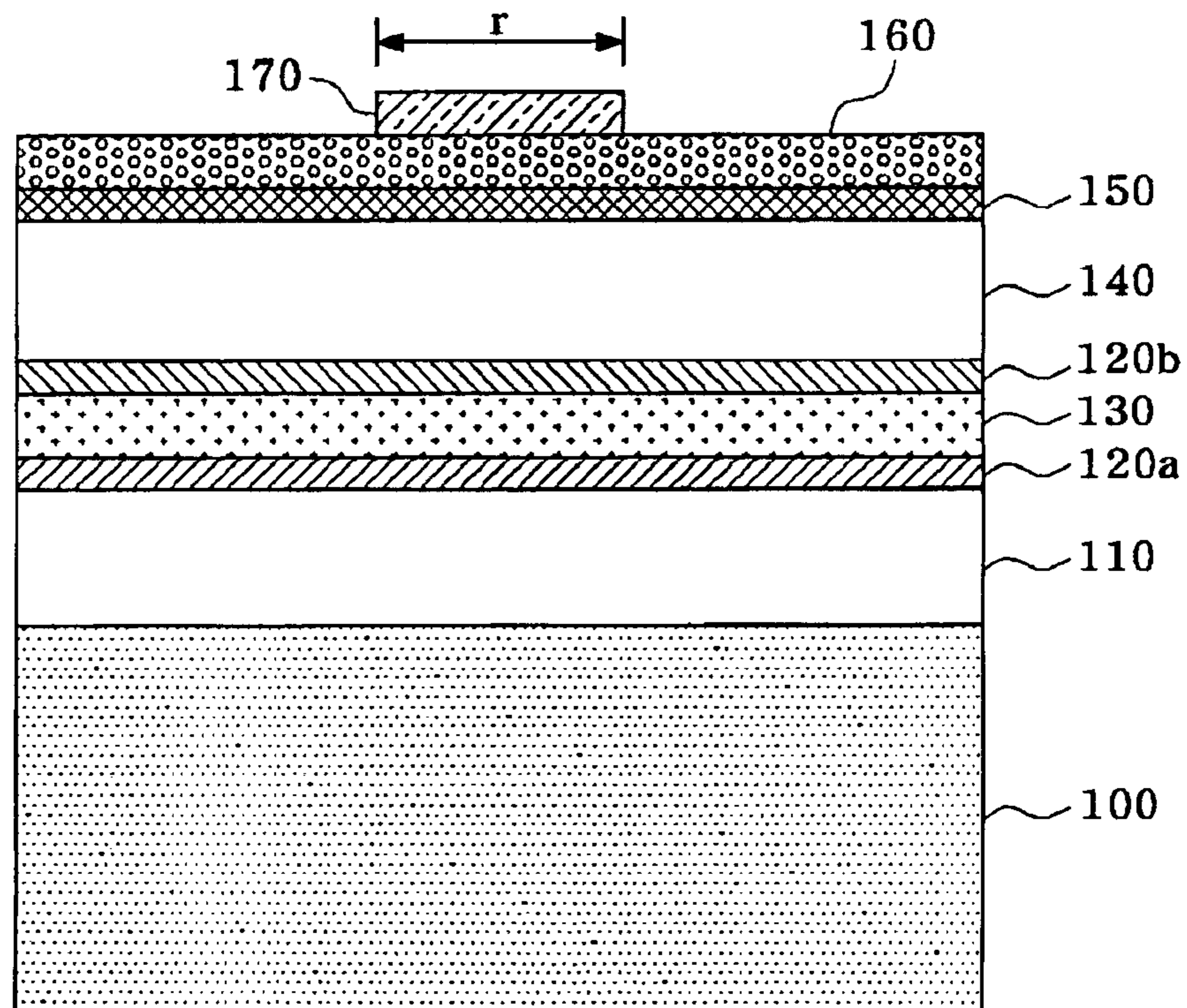

FIG. 1C

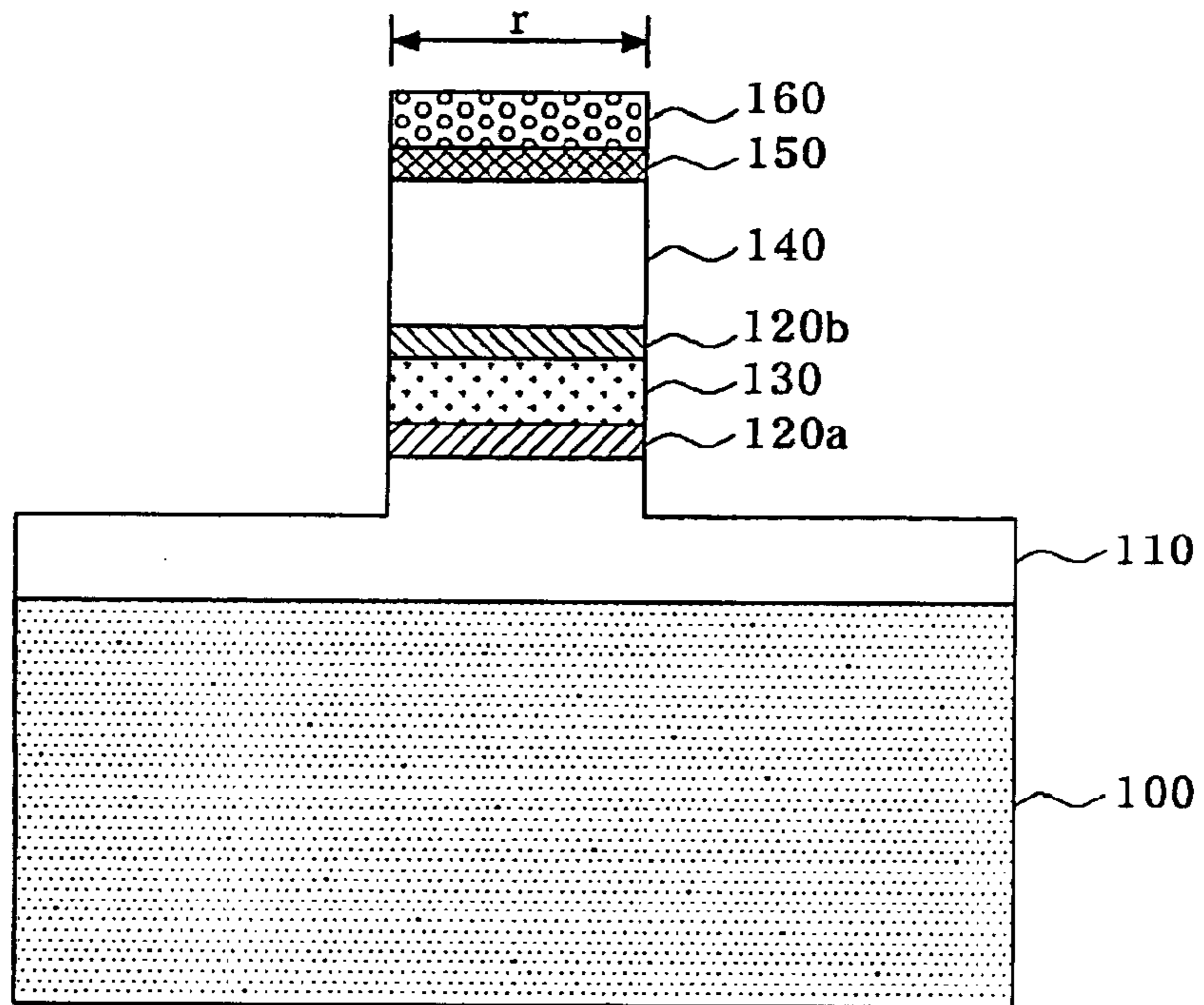
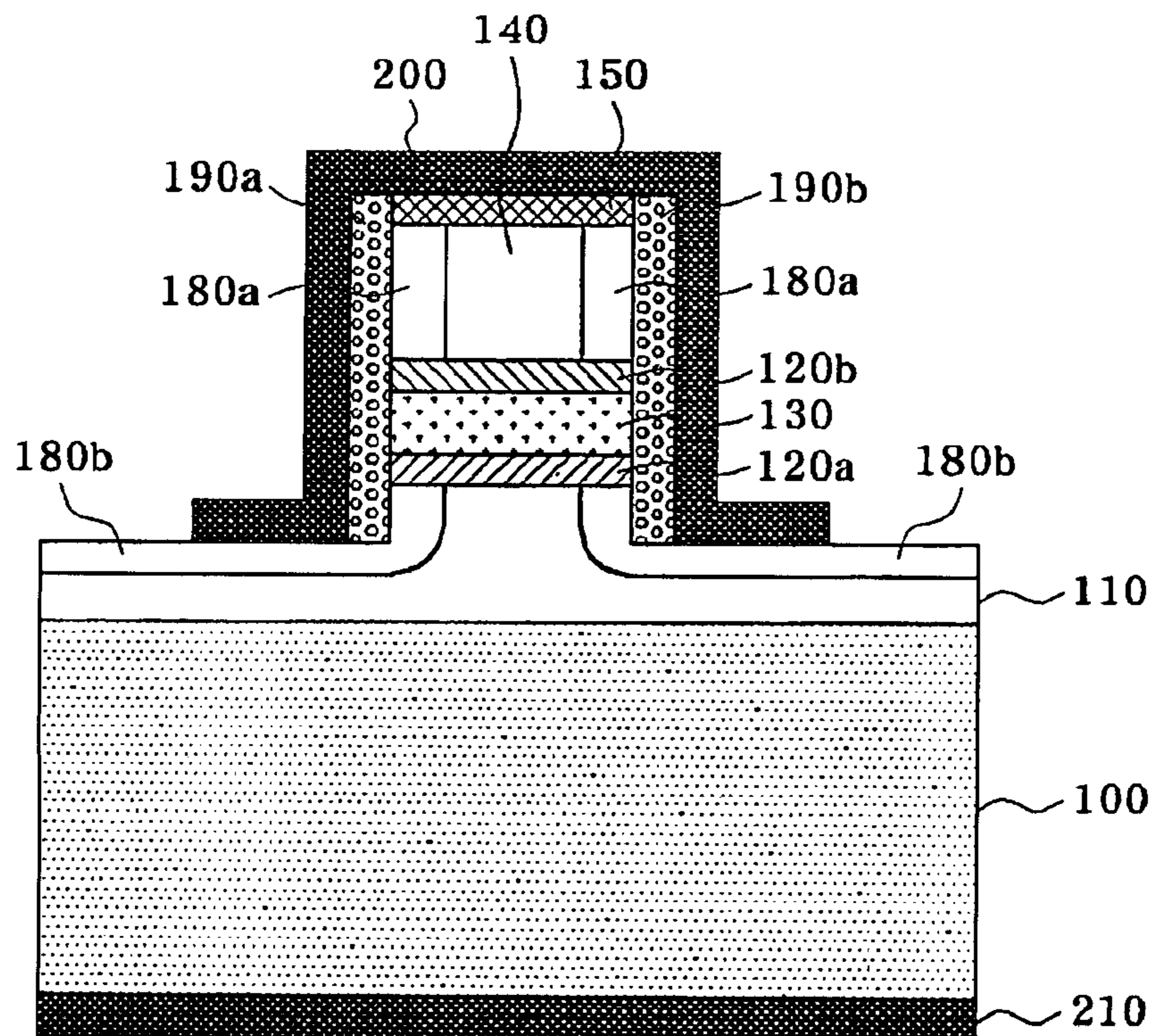

FIG. 1D



1

## SEMICONDUCTOR LASER DIODE AND METHOD OF MANUFACTURING THE SAME

**Matter enclosed in heavy brackets [ ] appears in the original patent but forms no part of this reissue specification; matter printed in italics indicates the additions made by reissue.**

### CROSS-REFERENCE TO RELATED [APPLICA- TION] PATENT APPLICATIONS

This application [claims priority to and] *is for a reissue of U.S. Pat. No. 7,508,857, issued on Mar. 24, 2009, from application Ser. No. 11/265,712, filed on Nov. 2, 2005, which claims the benefit of Korean Patent Application No. 2004-105818, filed Dec. 14, 2004, and claims the benefit of Korean Patent Application No. 2005-43466, filed May 24, 2005, the [disclosure] entire disclosures of which [is] are incorporated herein by reference [in its entirety] for all purposes.*

### BACKGROUND

#### 1. Field of the Invention

The present invention relates to a deep ridge waveguide (RWG) laser diode, which employs quantum dots as an active layer and is used for optical communication, and a method of manufacturing the same, and more specifically, to a semiconductor laser diode and a method of manufacturing the same, which can freely control the width of a ridge and automatically form an ohmic contact surface by wet oxidation on portions of upper and lower cladding layers, so that the semiconductor laser diode can be manufactured in an easier manner than the conventional method and improved in characteristics.

#### 2. Discussion of Related Art

In general, a conventional RWG laser diode, which uses an active layer as a quantum well (QW) layer, includes a ridge on which an ohmic contact surface is formed. In this case, since the ohmic contact surface should be smaller in width than the ridge, the RWG laser diode can be degraded in characteristics.

In order to overcome such drawbacks, it is necessary to develop a new technique of minimizing the width of the ridge while maximizing the width of the ohmic contact surface when an RWG laser diode is manufactured.

### SUMMARY OF THE INVENTION

The present invention is directed to a semiconductor laser diode and a method of manufacturing the same, which can freely control the width of a ridge and automatically form an ohmic contact surface by performing a wet oxidation process on portions of upper and lower cladding layers, so that the semiconductor laser diode can be manufactured in an easier manner than the conventional method and improved in characteristics.

One aspect of the present invention is to provide a semiconductor laser diode including: a lower cladding layer disposed on a substrate; a ridge including an optical waveguide layer, an active layer, an upper cladding layer, and an ohmic contact layer, which are sequentially stacked on the lower cladding layer, and having a predetermined width, which is obtained by performing a channel etching process on both sides of the ridge;

an oxide layer disposed on surfaces of the upper and lower cladding layer to control the width of the ridge; a dielectric layer disposed on left and right channels of the ridge; an upper

2

electrode layer disposed on the entire surface of the resultant structure to enclose the ridge and the dielectric layer; and a lower electrode layer disposed on a bottom surface of the substrate.

Another aspect of the present invention is to provide a method of manufacturing a semiconductor laser diode including the steps of: sequentially forming a lower cladding layer, an optical waveguide layer, an active layer, an upper cladding layer, and an ohmic contact layer on a substrate; forming a ridge having a predetermined width by sequentially removing the ohmic contact layer, the upper cladding layer, the active layer, and the optical waveguide layer using a predetermined photoresist layer as an etch mask until a portion of the lower cladding layer is exposed; forming an oxide layer on exposed surfaces of the upper and lower cladding layers; forming a dielectric layer on the entire surface of the resultant structure to enclose the ridge; removing the dielectric layer to expose the ohmic contact layer; forming an upper electrode layer on the entire surface of the resultant structure to enclose the ridge and the remaining dielectric layer; and forming a lower electrode layer on a bottom surface of the substrate.

### BRIEF DESCRIPTION OF THE DRAWINGS

The above and other features and advantages of the present invention will become more apparent to those of ordinary skill in the art by describing in detail exemplary embodiments thereof with reference to the attached drawings in which:

FIGS. 1A through 1D are cross-sectional views illustrating a method of manufacturing a semiconductor laser diode according to an exemplary embodiment of the present invention.

### DETAILED DESCRIPTION OF EXEMPLARY EMBODIMENTS

The present invention will now be described more fully hereinafter with reference to the accompanying drawings, in which exemplary embodiments of the invention are shown.

This invention may, however, be embodied in different forms and should not be construed as limited to the embodiments set forth herein. Rather, these embodiments are provided so that this disclosure is thorough and complete and fully conveys the scope of the invention to those skilled in the art. The same reference numerals are used to denote the same elements.

FIGS. 1A through 1D are cross-sectional views illustrating a method of manufacturing a semiconductor laser diode according to an exemplary embodiment of the present invention.

Referring to FIG. 1A, a lower cladding layer **110**, a first optical waveguide layer **120a**, an active layer **130**, a second optical waveguide layer **120b**, an upper cladding layer **140**, and an ohmic contact layer **150** are sequentially formed on, for example, an InP (001) substrate **100**.

In this case, the lower cladding layer **110** is an n-type  $\text{In}_{0.52}\text{Al}_{0.48}\text{As}$  layer, which is lattice-matched to the InP substrate **100**, and may be formed to a thickness of about 1 to 2  $\mu\text{m}$ , preferably, about 1.5  $\mu\text{m}$ .

Each of the first and second optical waveguide layers **120a** and **120b** is an undoped  $\text{In}_{0.52}\text{Al}_{0.25}\text{Ga}_{0.23}\text{As}$  layer having a separate confinement heterostructure (SCH) structure, which is lattice-matched to the InP substrate **100**, and may be formed to a thickness of about 130 to 170 nm, preferably, about 150 nm.

The active layer **130** may be formed by repetitively forming InAs quantum dots and an undoped  $\text{In}_{0.52}\text{Al}_{0.25}\text{Ga}_{0.23}\text{As}$  barrier layer in 3 to 7 cycles. The InAs quantum dots are

spontaneously formed from InAs that is (about 3.2%) lattice-mismatched to the InP substrate **100**, and the undoped  $\text{In}_{0.52}\text{Al}_{0.25}\text{Ga}_{0.23}\text{As}$  barrier layer is lattice-matched to the InP substrate **100**. Here, the thickness of the barrier layer may range from about 15 to 30 nm.

The upper cladding layer **140** is a p-type  $\text{In}_{0.52}\text{Al}_{0.48}\text{As}$  layer, which is lattice-matched to the InP substrate **100**, and may be formed to a thickness of about 1 to 2  $\mu\text{m}$ , preferably, about 1.5  $\mu\text{m}$ .

The ohmic contact layer **150** is a p-type  $\text{In}_{0.53}\text{Ga}_{0.47}\text{As}$  layer, which is lattice-matched to the InP substrate **100**, and may be formed to a thickness of about 130 to 170 nm, preferably, about 150 nm.

Meanwhile, the lower cladding layer **110**, the first and second optical waveguide layers **120a** and **120b**, the active layer **130**, the upper cladding layer **140**, and the ohmic contact layer **150** may be formed using, for example, a molecular beam epitaxy (MBE) apparatus or a metal organic chemical vapor deposition (MOCVD) apparatus.

Referring to FIG. 1B, a first  $\text{SiN}_x$  dielectric layer **160** is deposited on the ohmic contact layer **150** to a thickness of about 180 to 220 nm, preferably, about 200 nm, and a predetermined photoresist layer is coated thereon.

Next, a photoresist stripe **170** is formed using, for example, a photolithography process such that a ridge having a predetermined width "r" is formed.

Referring to FIG. 1C, by using the photoresist stripe **170** as an etch mask, the first dielectric layer **160** is etched to the same width as the photoresist stripe **170** using, for example, a dry or wet etching process. Then, the photoresist stripe **170** is removed.

Thereafter, by using the remaining first dielectric layer **160** as an etch mask, the ohmic contact layer **150**, the upper cladding layer **140**, the second optical waveguide layer **120b**, the active layer **130**, and the first optical waveguide layer **120a** are sequentially removed using, for example, a dry or wet etching process, such that the lower cladding layer **110** is exposed.

In order to form a deep ridge structure, the lower cladding layer **110** may be etched to a predetermined thickness.

Here, the ridge structure refers to a central protruding portion that is comprised of a portion of the lower cladding layer **110** and the remaining first waveguide layer **120a**, active layer **130**, second optical waveguide layer **120b**, upper cladding layer **140**, and ohmic contact layer **150**.

Referring to FIG. 1D, a wet oxidation process is carried out, for example, in an  $\text{H}_2\text{O}$  atmosphere for about 1 to 7 hours at a temperature of about 480 to 520° C., preferably, about 500° C. Thus, Al oxide layers **180a** and **180b** are formed on surfaces of the exposed upper and lower cladding layers **140** and **110**, respectively.

In this case, an  $\text{In}_{0.52}\text{Al}_{0.48}\text{As}$  layer has an oxidation rate of about 162.5 nm/hr in a direction parallel to the InP substrate **100** and an oxidation rate of about 185.5 nm/hr in a direction vertical to the InP substrate **100**, and the oxidation rate of an  $\text{In}_{0.52}\text{Al}_{0.25}\text{Ga}_{0.23}\text{As}$  layer is about 1/100 the oxidation rate of the  $\text{In}_{0.52}\text{Al}_{0.48}\text{As}$  layer. Owing to a difference in Al content, the  $\text{In}_{0.52}\text{Al}_{0.48}\text{As}$  layer is different in oxidation rate from the  $\text{In}_{0.52}\text{Al}_{0.25}\text{Ga}_{0.23}\text{As}$  layer.

Accordingly, by controlling the wet oxidation time, when the active layer **130** is much less oxidized than the upper and lower cladding layers **140** and **110**, it is possible to freely control the width "r" of the ridge.

After the oxidation process, second  $\text{SiN}_x$  dielectric layers **190a** and **190b** are deposited to enclose the ridge to a thickness of about 180 to 220 nm, preferably, about 200 nm, and then removed using, for example, a dry etching process until

the ohmic contact layer **150** is exposed. Thus, an ohmic contact surface is automatically formed.

In this case, the dry etching process may be, for example, a magnetically enhanced reactive ion etching (MERIE) process.

Thereafter, an upper electrode layer **220** is formed of a p-type metal on the entire surface of the resultant structure to enclose the ridge and the second dielectric layers **190a** and **190b**. A bottom portion of the InP substrate **100** is lapped, and a lower electrode layer **210** is formed of an n-type metal on a bottom surface of the InP substrate **100**. Thus, a deep RWG semiconductor laser diode according to the exemplary embodiment of the present invention is completed.

As described above, according to exemplary embodiments of the present invention, a wet oxidation process is performed on portions of upper and lower cladding layer of a deep ridge structure, so that the width of a ridge can be freely controlled and an ohmic contact surface can be automatically formed. As a result, the width of the ridge can be sufficiently reduced, thus lowering the threshold current density and contact resistance of a semiconductor laser diode. Therefore, the semiconductor laser diode of the present invention can be improved in characteristics and manufactured in an easier manner than the conventional method.

In the drawings and specification, there have been disclosed typical preferred embodiments of the invention and, although specific terms are employed, they are used in a generic and descriptive sense only and not for purposes of limitation. As for the scope of the invention, it is to be set forth in the following claims. Therefore, it will be understood by those of ordinary skill in the art that various changes in form and details may be made therein without departing from the spirit and scope of the present invention as defined by the following claims.

What is claimed is:

1. A semiconductor laser diode comprising:

a lower cladding layer comprising InAlAs disposed on a substrate;

a ridge including an optical waveguide layer, a quantum dot active layer, an upper cladding layer comprising InAlAs, and an ohmic contact layer, which are sequentially stacked on the lower cladding layer, and having a predetermined width, which is obtained by performing a channel etching process on both sides of the ridge, wherein the ridge also includes a portion of the lower cladding layer;

an oxide layer formed by oxidizing surfaces of the upper and lower cladding layer to control an effective width of the ridge;

a dielectric layer disposed on left and right channels of the ridge;

an upper electrode layer disposed on the entire surface of the resultant structure to enclose the ridge and the dielectric layer; and

a lower electrode layer disposed on a bottom surface of the substrate,

wherein the upper and lower cladding layers have a faster oxidation rate than that of the optical waveguide layer and active layer so that the formation of the oxide layer substantially changes the effective width of the ridge without substantially changing the predetermined width of the active layer or the optical waveguide layer.

2. The semiconductor laser diode according to claim 1, further comprising an additional optical waveguide layer interposed between the active layer and the upper cladding layer.

## 5

3. The semiconductor laser diode according to claim 1, wherein the upper and lower cladding layers are a p-type InAlAs layer and an n-type InAlAs layer, respectively, which are lattice-matched to the substrate.

4. The semiconductor laser diode according to claim 3, wherein each of the upper and lower cladding layers is formed to a thickness of about 1 to 2  $\mu\text{m}$ .

5. The semiconductor laser diode according to claim 1, wherein the optical waveguide layer is an undoped InAlGaAs layer having a separate confinement heterostructure (SCH) structure, which is lattice-matched to the substrate.

6. The semiconductor laser diode according to claim 5, wherein the optical waveguide layer is formed to a thickness of about 130 to 170 nm.

7. The semiconductor laser diode according to claim 1, wherein the active layer is obtained by repetitively forming InAs quantum dots, which are spontaneously formed from InAs that is lattice-mismatched to the substrate, and an undoped InAlGaAs barrier layer, which is lattice-matched to the substrate, in several cycles.

8. The semiconductor laser diode according to claim 1, wherein the ohmic contact layer is a p-type InGaAs layer, which is lattice-matched to the substrate.

9. The semiconductor laser diode according to claim 8, wherein the ohmic contact layer is formed to a thickness of about 130 to 170 nm.

10. A semiconductor laser diode comprising:  
a lower cladding layer comprising InAlAs disposed on a substrate;

a ridge including an optical waveguide layer, a quantum dot active layer, an upper cladding layer comprising InAlAs, and an ohmic contact layer, which are sequentially stacked on the lower cladding layer, and having a predetermined width, which is obtained by performing a channel etching process on both sides of the ridge, wherein the ridge also includes a portion of the lower cladding layer;

an oxide layer formed by oxidizing surfaces of the upper and lower cladding layer to control an effective width of the ridge;

a dielectric layer disposed on left and right channels of the ridge;

an upper electrode layer disposed on the entire surface of the resultant structure to enclose the ridge and the dielectric layer; and

a lower electrode layer,

wherein the upper and lower cladding layers have a faster oxidation rate than that of the optical waveguide layer and active layer so that the formation of the oxide layer substantially changes the effective width of the ridge without substantially changing the predetermined width of the active layer or the optical waveguide layer.

11. A semiconductor laser diode comprising:  
a lower cladding layer disposed on a substrate;

a ridge having a predetermined width, wherein the ridge comprises:

an optical waveguide layer, an active layer, and an upper cladding layer, which are stacked on the lower cladding layer, and

a portion of the lower cladding layer; and

an oxide layer formed by oxidizing surfaces of the upper and lower cladding layers,

wherein the upper and lower cladding layers have a faster oxidation rate than that of the optical waveguide layer and the active layer so that the formation of the oxide layer substantially changes an effective width of the ridge without substantially

## 6

changing the predetermined width of the active layer or the optical waveguide layer.

12. The semiconductor laser diode according to claim 11, wherein the lower and upper cladding layers comprise InAlAs.

13. The semiconductor laser diode according to claim 11, wherein the active layer is a quantum dot active layer.

14. The semiconductor laser diode according to claim 11, wherein the ridge is obtained by performing a channel etching process on both sides of the ridge.

15. The semiconductor laser diode according to claim 11, further comprising:

a dielectric layer disposed on at least one side of the ridge;

an upper electrode layer disposed on a surface of the dielectric layer, wherein the upper electrode layer encloses the ridge; and

a lower electrode layer disposed on a bottom surface of the substrate.

16. The semiconductor laser diode according to claim 11, further comprising an additional optical waveguide layer interposed between the active layer and the upper cladding layer.

17. The semiconductor laser diode according to claim 11, wherein the upper and lower cladding layers are a p-type InAlAs layer and an n-type InAlAs layer, respectively, which are lattice-matched to the substrate.

18. The semiconductor laser diode according to claim 11, wherein each of the upper and lower cladding layers is formed to a thickness of about 1 to 2  $\mu\text{m}$ .

19. The semiconductor laser diode according to claim 11, wherein the optical waveguide layer is undoped InAlGaAs layer having a separate confinement heterostructure (SCH) structure, which is lattice-matched to the substrate.

20. The semiconductor laser diode according to claim 11, wherein the optical waveguide layer is formed to a thickness of about 130 to 170 nm.

21. The semiconductor laser diode according to claim 11, wherein the active layer is obtained by repetitively forming InAs quantum dots, which are spontaneously formed from InAs that is lattice-mismatched to the substrate, and an undoped InAlGaAs barrier layer, which is lattice-matched to the substrate, in several cycles.

22. The semiconductor laser diode according to claim 11, further comprising a contact layer, wherein the contact layer is a p-type InGaAs layer, which is lattice-matched to the substrate.

23. The semiconductor laser diode according to claim 22, wherein the contact layer is formed to a thickness of about 130 to 170 nm.

24. The semiconductor laser diode according to claim 11, wherein the oxide layer is configured to control the effective width of the ridge.

25. A semiconductor laser diode comprising:  
a lower cladding layer disposed on a substrate;

a ridge having a predetermined width, wherein the ridge comprises:

an optical waveguide layer, an active layer, and an upper cladding layer, which are stacked on the lower cladding layer, and

a portion of the lower cladding layer;

a first oxide layer formed at one side of the upper cladding layer; and

a second oxide layer formed at one side of the lower cladding layer,

wherein the upper and lower cladding layers have a faster oxidation rate than that of the optical waveguide layer and the active layer.

7

26. The semiconductor laser diode according to claim 25, wherein the first and the second oxide layers are formed by oxidizing surfaces of the upper and lower cladding layers, respectively.

27. The semiconductor laser diode according to claim 26, wherein the first and the second oxide layers substantially change an effective width of the ridge without substantially changing the predetermined width of the active layer or the optical waveguide layer.

28. The semiconductor laser diode according to claim 25, wherein the lower and upper cladding layers comprise InAlAs.

29. The semiconductor laser diode according to claim 25, wherein the active layer is a quantum dot active layer.

30. The semiconductor laser diode according to claim 25, further comprising:

a dielectric layer disposed on at least one side of the ridge;  
 an upper electrode layer disposed on a surface of the dielectric layer, wherein the upper electrode layer encloses the ridge; and  
 a lower electrode layer disposed on a bottom surface of the substrate.

31. A semiconductor laser diode comprising:

a lower cladding layer disposed on a substrate; and  
 a ridge comprising a portion of the lower cladding layer, an optical waveguide layer, an active layer, and an upper cladding layer, wherein:  
 the upper cladding layer comprises an oxidated portion and a non-oxidated portion,

8

a width of the non-oxidated portion of the upper cladding layer is smaller than a width of the optical waveguide layer and a width of the active layer, and the upper and lower cladding layers have a faster oxidation rate than that of the optical waveguide layer and active layer.

32. The semiconductor laser diode according to claim 31, wherein the oxidated portion is formed by oxidizing a surface of the upper cladding layer.

33. The semiconductor laser diode according to claim 31, wherein the oxidated portion substantially changes an effective width of the ridge without substantially changing a width of the active layer or the optical waveguide layer.

34. The semiconductor laser diode according to claim 31, wherein the lower and upper cladding layers comprise InAlAs.

35. The semiconductor laser diode according to claim 31, wherein the active layer is a quantum dot active layer.

36. The semiconductor laser diode according to claim 31, further comprising:

a dielectric layer disposed on at least one side of the ridge;  
 an upper electrode layer disposed on a surface of the dielectric layer, wherein the upper electrode layer encloses the ridge; and  
 a lower electrode layer disposed on a bottom surface of the substrate.

\* \* \* \* \*