



US00RE44783E

(19) **United States**
(12) **Reissued Patent**
Scruggs

(10) **Patent Number:** **US RE44,783 E**
(45) **Date of Reissued Patent:** **Mar. 4, 2014**

(54) **FLUSHETTE PARTIAL AND FULL TOILET
FLUSH DEVICES**

(76) Inventor: **Donald E. Scruggs**, Chino, CA (US)

(21) Appl. No.: **12/660,678**

(22) Filed: **Mar. 1, 2010**

Related U.S. Patent Documents

Reissue of:

(64) Patent No.: **7,591,027**
Issued: **Sep. 22, 2009**
Appl. No.: **11/879,192**
Filed: **Jul. 16, 2007**

(51) **Int. Cl.**
E03D 1/14 (2006.01)

(52) **U.S. Cl.**
USPC **4/327; 4/415**

(58) **Field of Classification Search**
USPC **4/324–327, 415, 405**
See application file for complete search history.

(56) **References Cited**

U.S. PATENT DOCUMENTS

1,037,679 A	9/1912	Snyder	
1,323,703 A	12/1919	Linfoot	
1,474,288 A	11/1923	Rath	
1,604,428 A	10/1926	Veeder	
1,710,827 A	4/1929	Johnson	
1,767,043 A *	6/1930	Blaun et al.	4/326
2,182,873 A	12/1939	King	
2,320,886 A	6/1943	Quiroz	
2,351,672 A	6/1944	Engel	
2,389,413 A	11/1945	Carlton	
2,760,204 A	8/1956	Joania	
2,858,546 A	11/1958	Tekenos et al.	
2,940,084 A *	6/1960	Fabbi et al.	4/327

3,064,675 A	11/1962	Johnson et al.	
3,113,756 A	12/1963	Griffo	
3,320,622 A	5/1967	Wustner	
3,487,476 A	1/1970	Stiem et al.	
3,605,125 A	9/1971	Gibb et al.	
3,628,195 A	12/1971	Skousgaard	
3,689,025 A	9/1972	Kiser	
3,747,621 A	7/1973	Tine	
3,766,571 A *	10/1973	Elder et al.	4/326
3,810,261 A	5/1974	Hollander	
3,817,279 A	6/1974	Larson	
3,817,489 A	6/1974	Caron et al.	
3,820,171 A	6/1974	Larson	
3,820,754 A	6/1974	Caron et al.	
3,869,733 A *	3/1975	White	4/327
3,879,765 A	4/1975	Moon	
3,894,299 A	7/1975	Cleary	
3,903,551 A	9/1975	Johnson	
3,905,050 A	9/1975	Goza et al.	
3,906,554 A *	9/1975	Johnson	4/327
3,988,786 A	11/1976	Lehfeltd	
4,003,399 A	1/1977	Fischer	
4,014,050 A	3/1977	Goldsworthy	
4,034,423 A	7/1977	Milnes	
4,042,982 A *	8/1977	Contreras	4/326
4,056,856 A	11/1977	Reid et al.	
4,060,857 A	12/1977	Couton	
4,077,602 A	3/1978	Klessig	
4,088,297 A	5/1978	Doyle et al.	
4,115,881 A	9/1978	Stone	
4,128,906 A	12/1978	Raz	
4,135,263 A	1/1979	Anderson	

(Continued)

Primary Examiner — Gregory Huson
Assistant Examiner — Janie Christiansen

(57) **ABSTRACT**

Toilet flapper valves with multiple volume flush capability which can be quickly and easily installed to replace existing flapper valves in old or new toilets to give such toilets the capability of providing selectable amounts of flushing water.

4 Claims, 7 Drawing Sheets

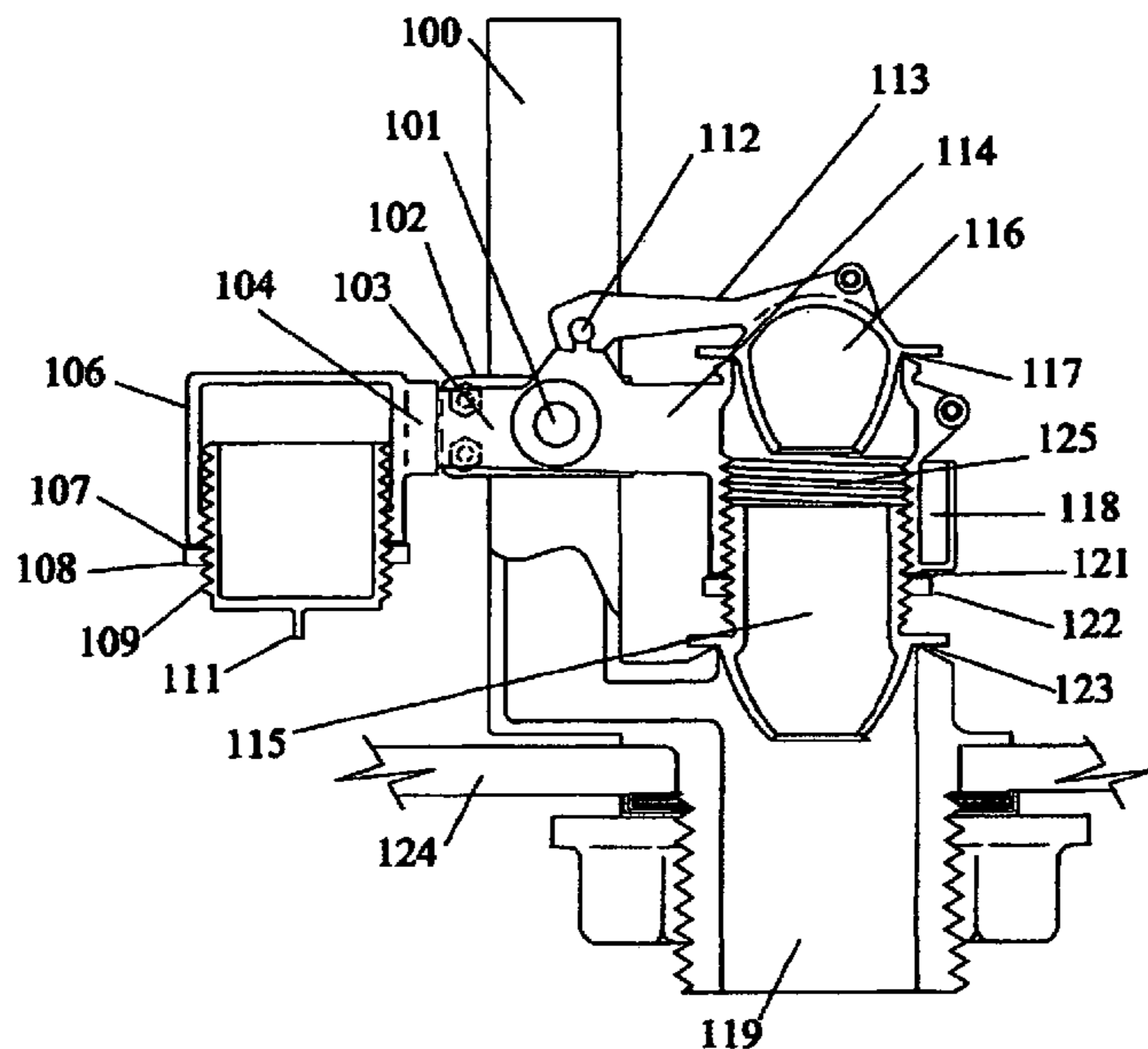

(56)

References Cited

U.S. PATENT DOCUMENTS

4,141,091 A	2/1979	Pulvari	5,459,885 A	10/1995	Gaw
4,141,092 A	2/1979	Jones	5,464,037 A	11/1995	Younes
4,175,296 A	11/1979	Goldman	5,500,961 A	3/1996	Tsai
4,193,145 A	3/1980	Gross et al.	5,519,253 A	5/1996	Gao et al.
4,225,987 A	10/1980	Goldman et al.	5,519,898 A	5/1996	Guo et al.
4,233,698 A	11/1980	Martin	5,524,297 A	6/1996	Harrison
4,304,015 A	12/1981	Hubatka	5,548,850 A	8/1996	Geeham
4,305,163 A	12/1981	Raz	5,555,573 A	9/1996	Jensen
4,357,720 A	11/1982	Stahli	5,594,959 A	1/1997	Nichols-Roy et al.
4,406,024 A	9/1983	Chiu et al.	5,603,127 A	2/1997	Veal
4,411,029 A	10/1983	Huang	5,649,686 A	7/1997	Wilson
4,485,501 A *	12/1984	Kloner 4/324	5,652,970 A	8/1997	Wodeslavsky
4,499,615 A	2/1985	Radovsky	5,659,903 A	8/1997	Hammarstedt
4,530,119 A	7/1985	Chiu et al.	5,673,440 A	10/1997	Carmona
4,536,900 A *	8/1985	Hayes 4/324	5,711,039 A	1/1998	Mizrahi
4,575,880 A	3/1986	Burgess	5,713,086 A	2/1998	Dichelan
4,624,018 A	11/1986	Kurtz	5,722,454 A	3/1998	Smith et al.
4,646,780 A	3/1987	Spooner	5,754,986 A *	5/1998	Chien 4/327
4,662,395 A	5/1987	Strangfeld	5,794,278 A	8/1998	Kirt
4,707,868 A	11/1987	Hennessy	5,802,628 A	9/1998	Spoeth et al.
4,750,220 A	6/1988	Baumann	5,806,108 A	9/1998	Mizrahi
4,756,031 A	7/1988	Barrett	5,857,661 A	1/1999	Amada et al.
4,791,689 A	12/1988	Garcia De Couto	5,873,136 A	2/1999	Geeham
4,817,216 A	4/1989	Auman	5,887,292 A	3/1999	Goren
4,832,310 A	5/1989	Nestich	5,896,593 A	4/1999	Mizrahi
4,878,256 A	11/1989	Bagwell	5,920,919 A	7/1999	Chang
4,937,894 A	7/1990	Hill, Jr. et al.	5,970,527 A	10/1999	Martin et al.
4,941,215 A	7/1990	Liu	6,123,315 A	9/2000	Keller
4,945,580 A	8/1990	Schmitt et al.	6,263,519 B1	7/2001	Parsons et al.
4,996,726 A	3/1991	Schrock et al.	6,321,395 B1	11/2001	Parsons et al.
5,003,643 A	4/1991	Chung	6,370,707 B1	4/2002	Parsons et al.
5,005,226 A	4/1991	Basile et al.	6,393,624 B1	5/2002	Iwashita
5,046,201 A	9/1991	Steinhardt et al.	6,421,844 B1	7/2002	Scott
5,052,060 A	10/1991	Makita	6,453,479 B1	9/2002	Parsons et al.
5,070,547 A	12/1991	Comparetti	6,467,100 B2	10/2002	Leach
5,121,510 A *	6/1992	Ricalde Medina 4/326	6,510,563 B1 *	1/2003	Jarosinski et al. 4/326
5,187,818 A	2/1993	Barrett et al.	6,510,866 B2	1/2003	Li
5,206,960 A	5/1993	Hooshley et al.	6,637,042 B2 *	10/2003	Hand 4/327
5,243,713 A	9/1993	More	6,742,194 B2 *	6/2004	Shim 4/325
5,261,129 A	11/1993	Roy	6,775,859 B1	8/2004	Gorginians
5,301,373 A	4/1994	Hull et al.	6,782,564 B1	8/2004	Cheng
5,309,942 A	5/1994	Oril et al.	6,795,982 B2	9/2004	Noboru et al.
5,313,673 A	5/1994	Sandi et al.	6,823,534 B2	11/2004	Li
5,335,694 A	8/1994	Whiteside	6,898,808 B2	5/2005	Molho et al.
5,341,839 A	8/1994	Kobayashi et al.	6,920,649 B2	7/2005	Oury
5,361,426 A	11/1994	Martin	6,934,976 B2	8/2005	Parsons et al.
5,396,665 A	3/1995	Raz et al.	6,962,163 B1	11/2005	Edwards
5,400,445 A	3/1995	Hull	6,966,536 B2	11/2005	Enomoto et al.
5,400,446 A	3/1995	Bloemer	7,028,975 B2	4/2006	Lee et al.
5,427,351 A	6/1995	Korigen	7,069,604 B2	7/2006	Tomita et al.
5,431,181 A	7/1995	Saadi	7,082,624 B2	8/2006	Yen
5,435,019 A	7/1995	Badders	7,096,517 B2	8/2006	Gubeli et al.
			7,159,251 B2	1/2007	Hennessy

* cited by examiner

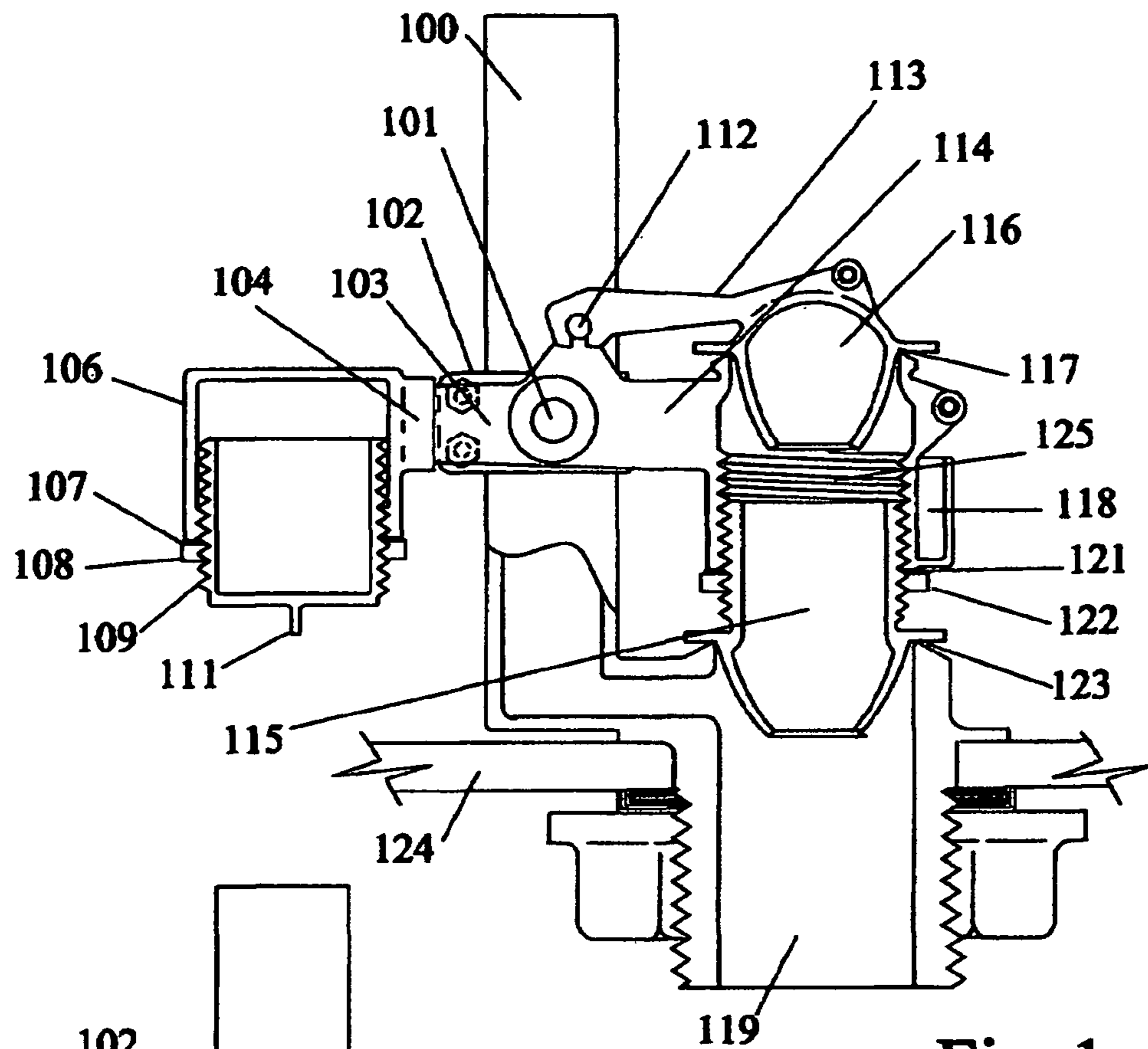

Fig. 1

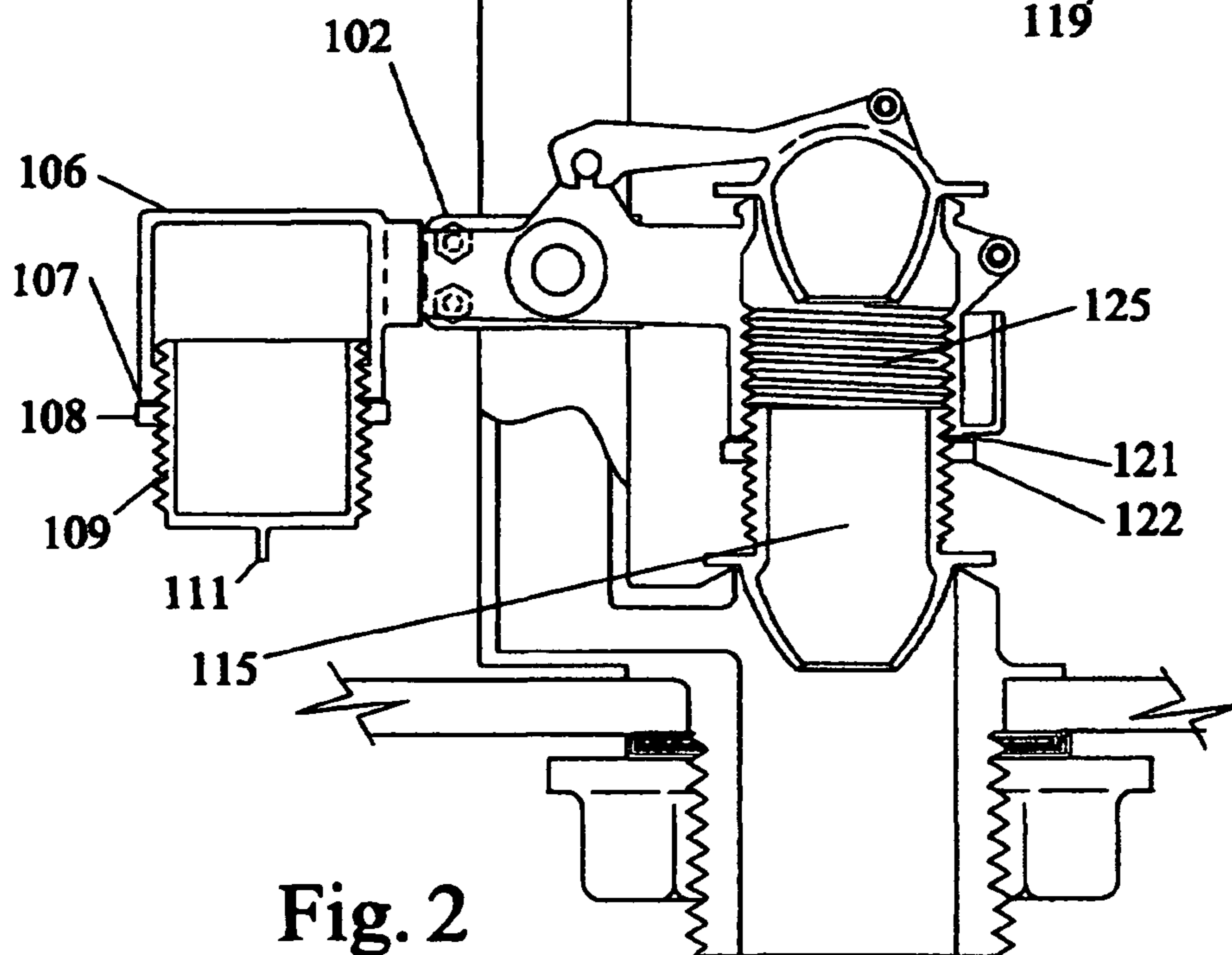

Fig. 2

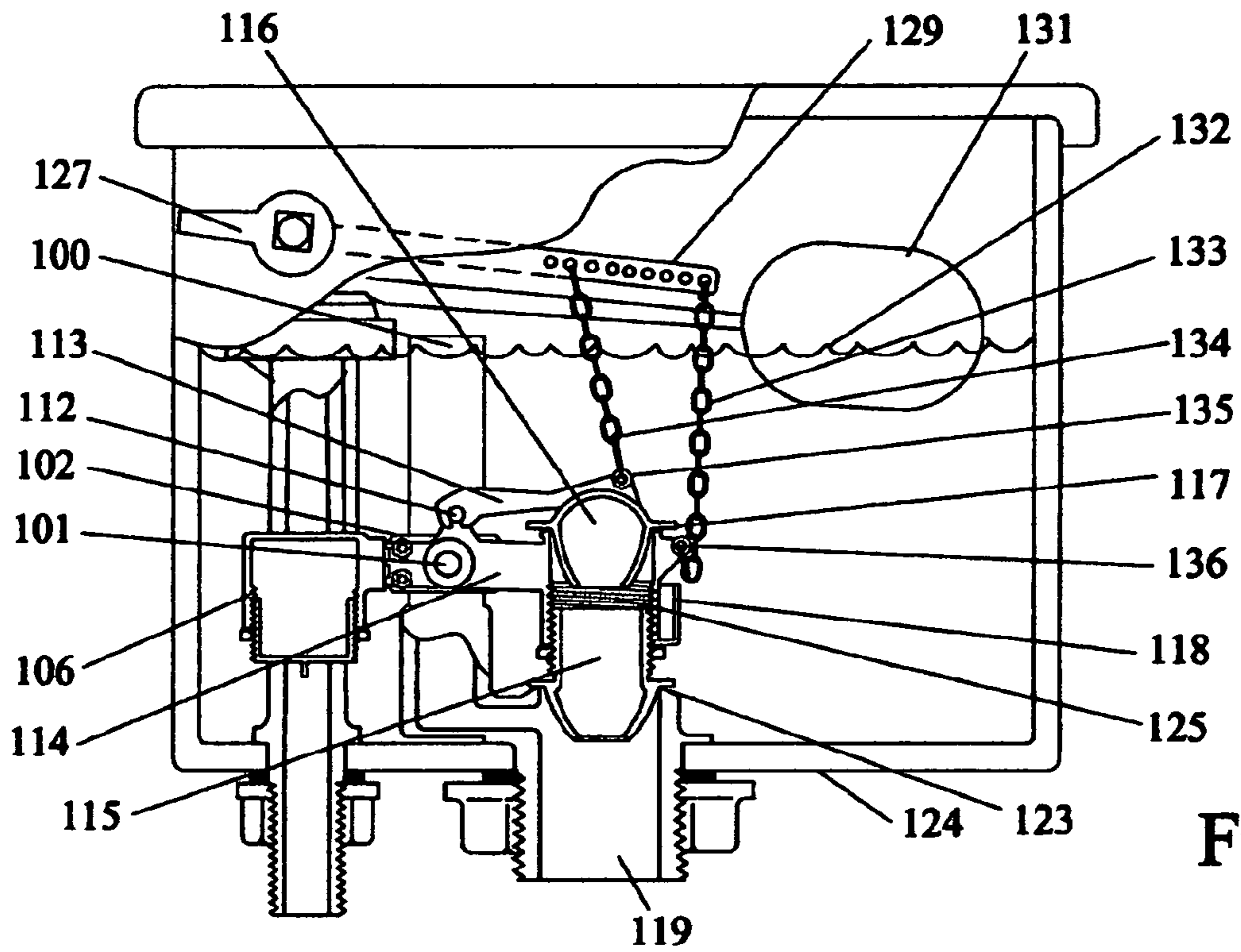

Fig. 3

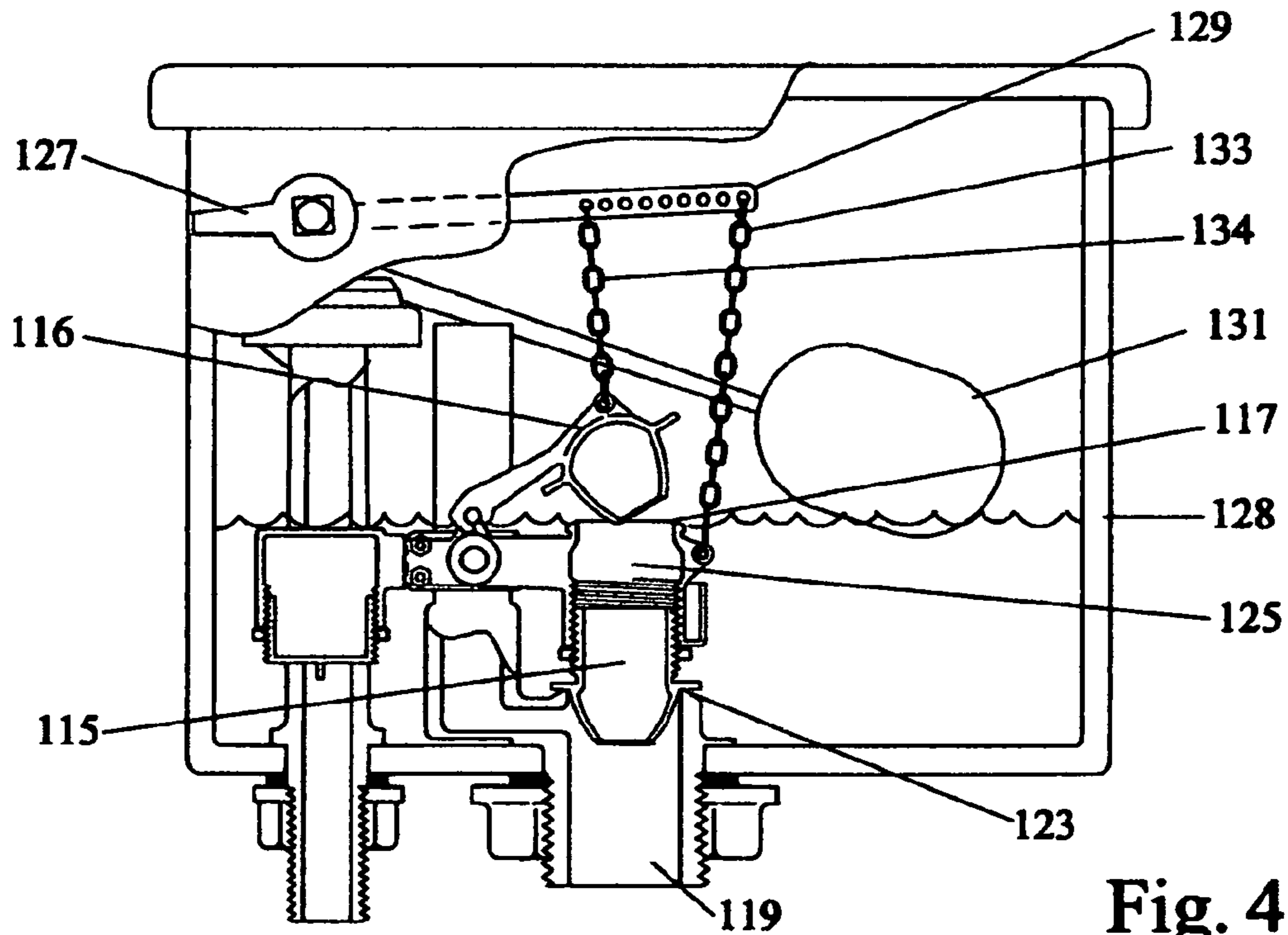

Fig. 4

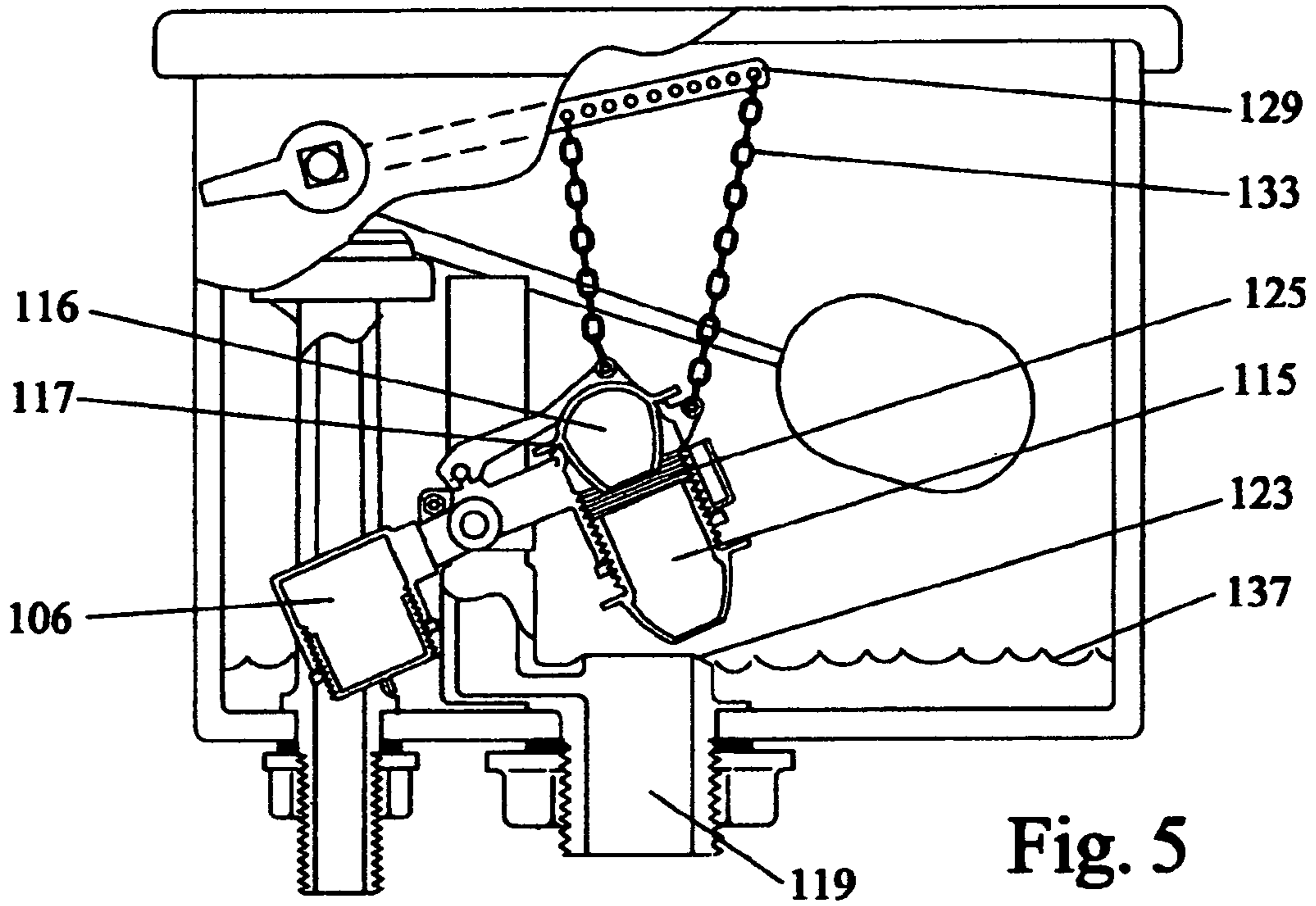

Fig. 5

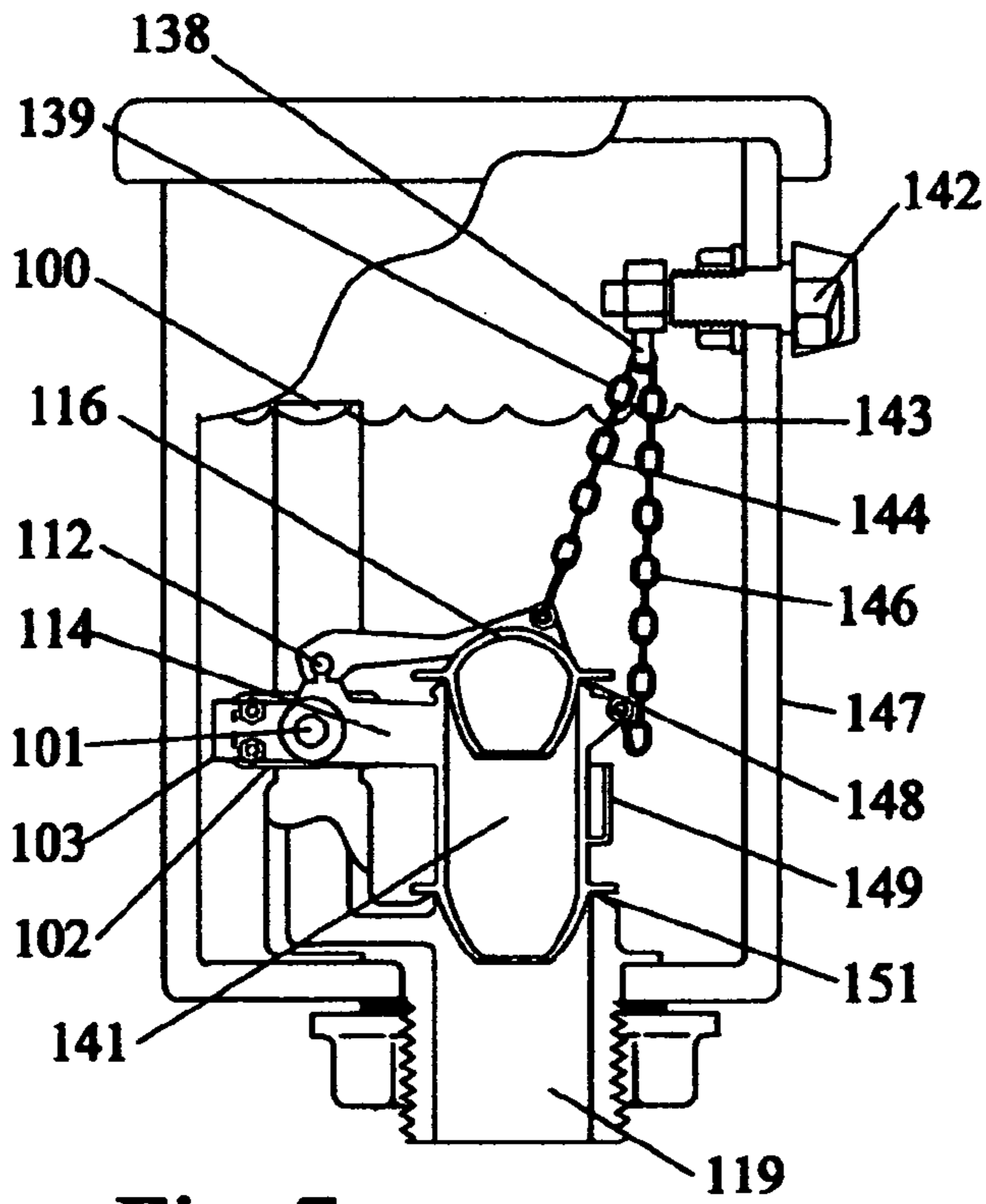

Fig. 7

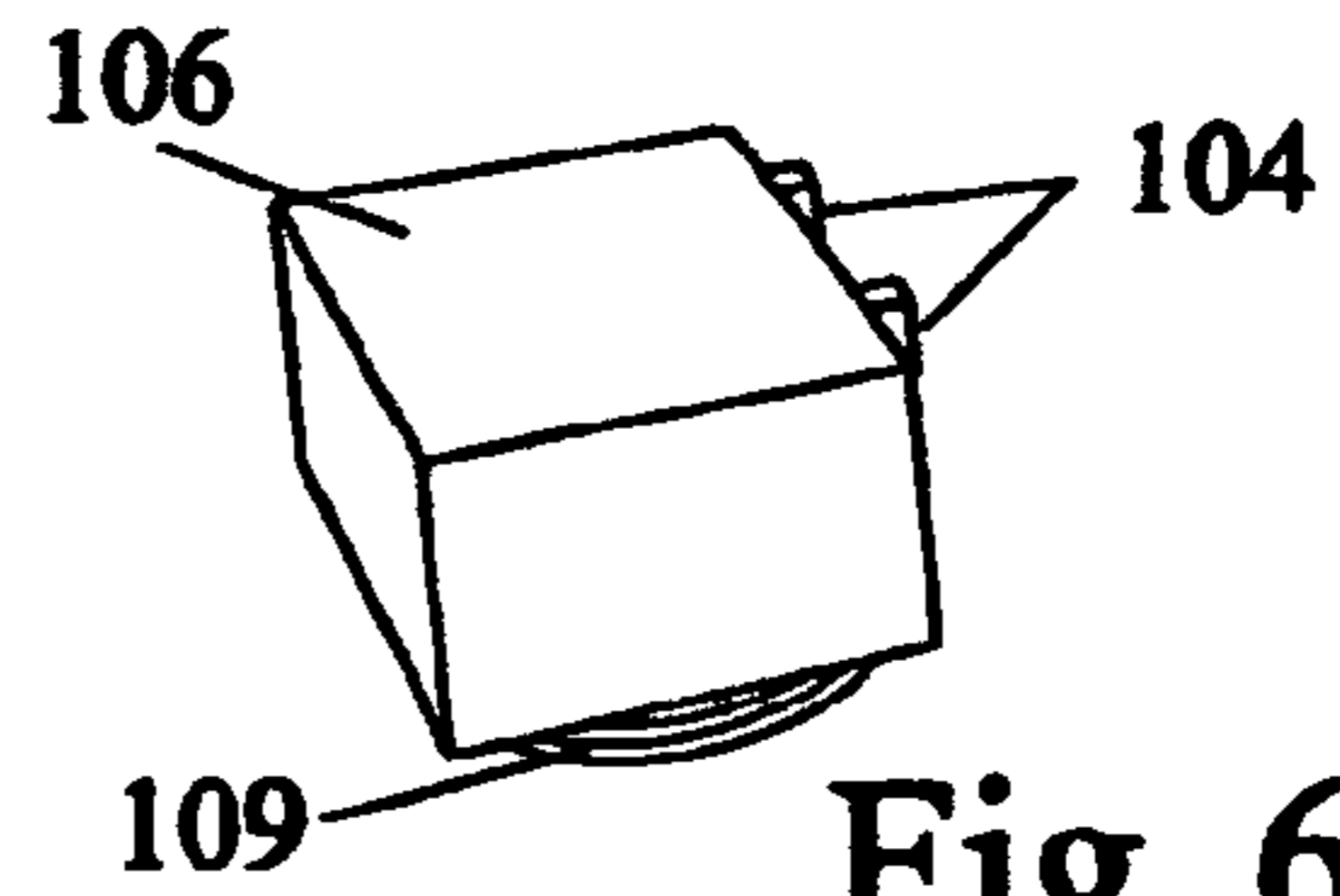

Fig. 6

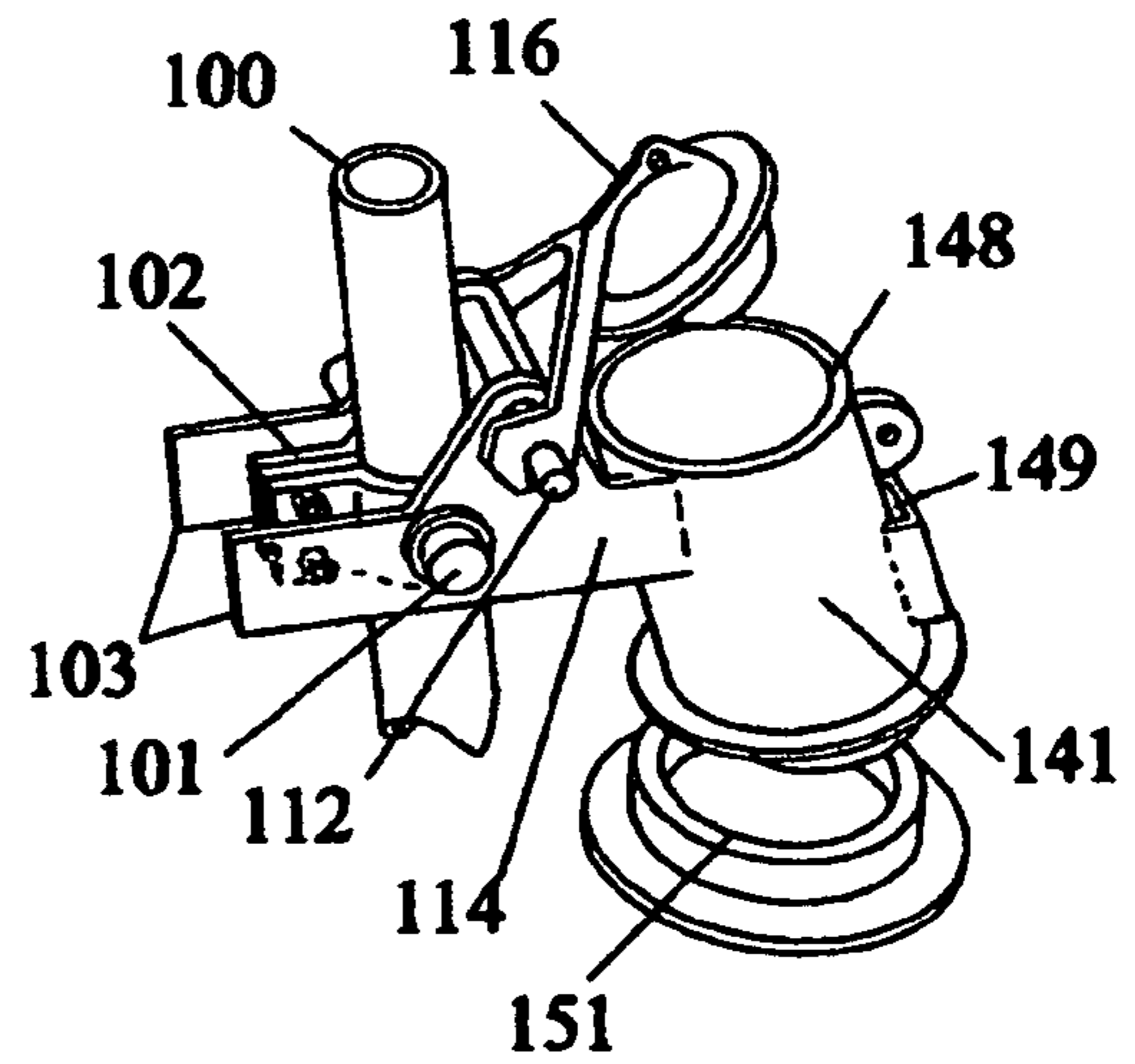
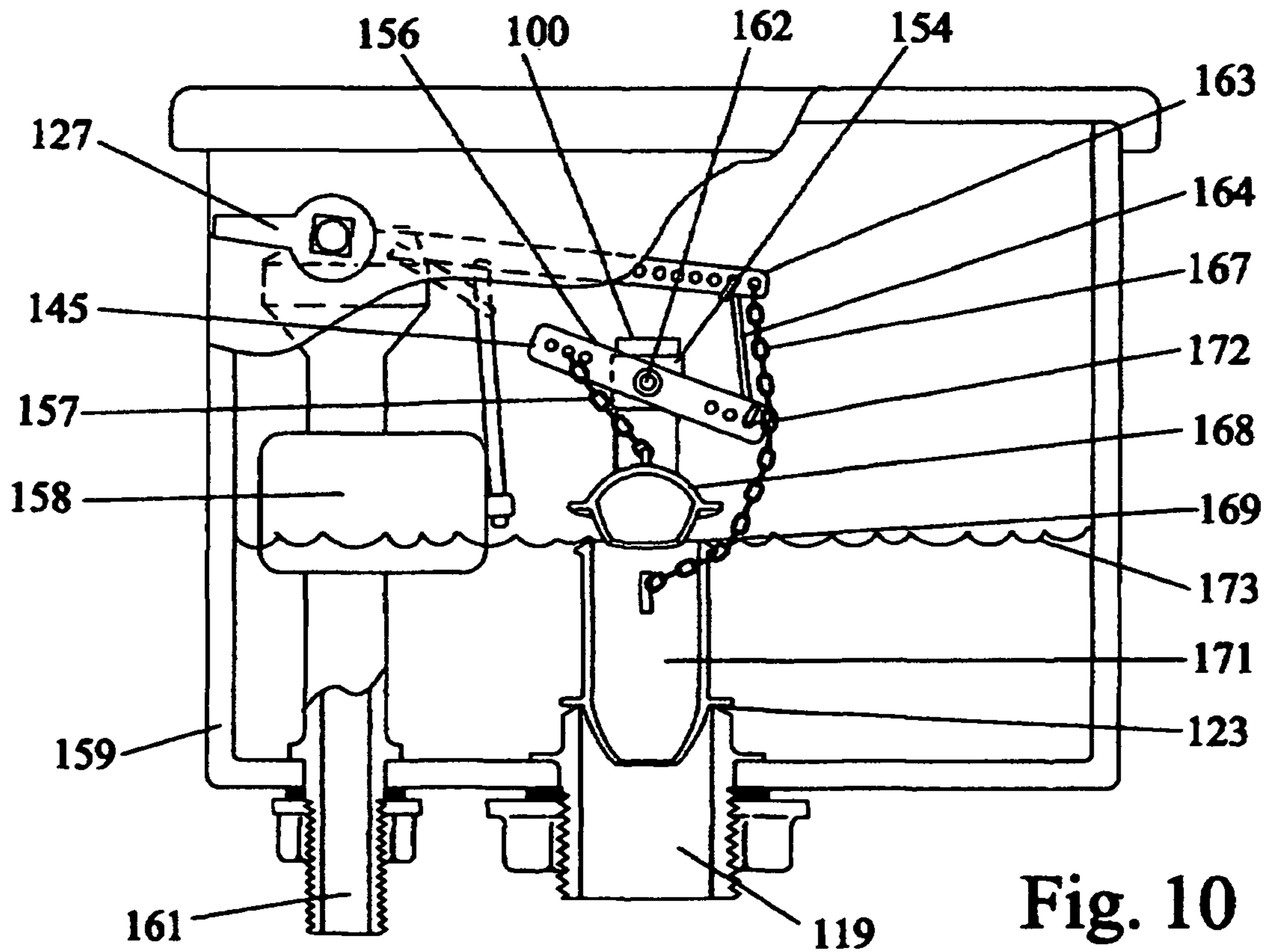
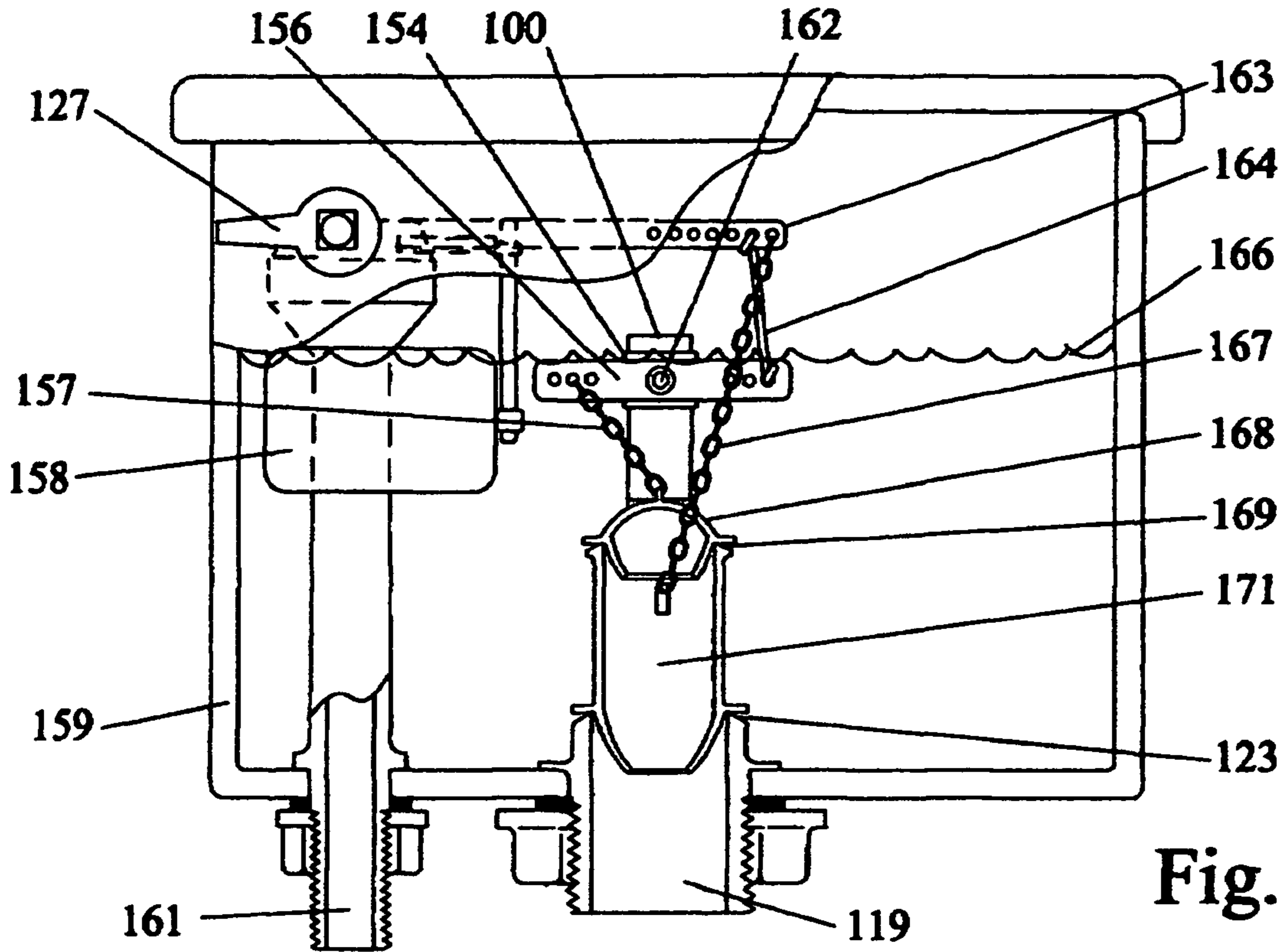

Fig. 8



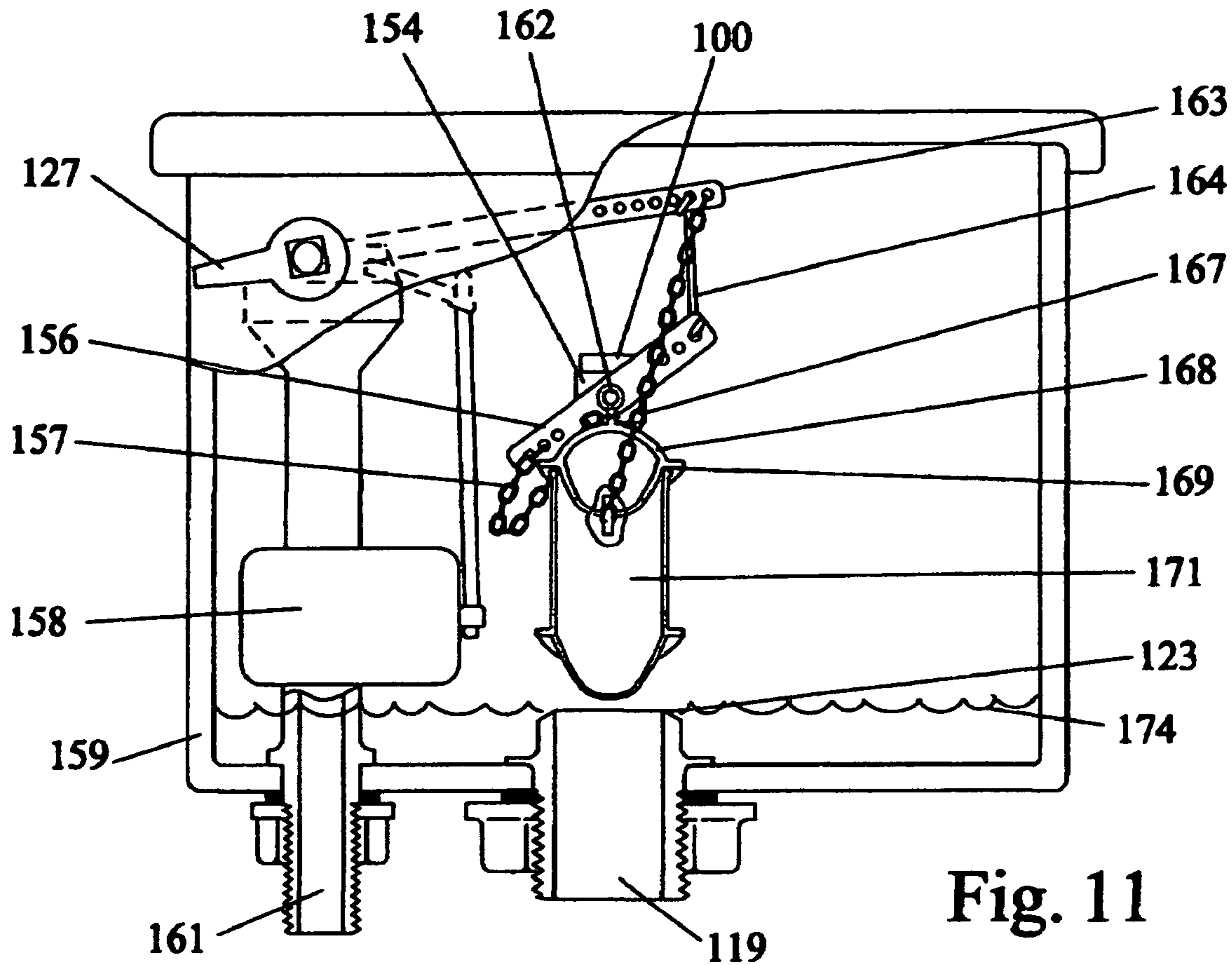

Fig. 11

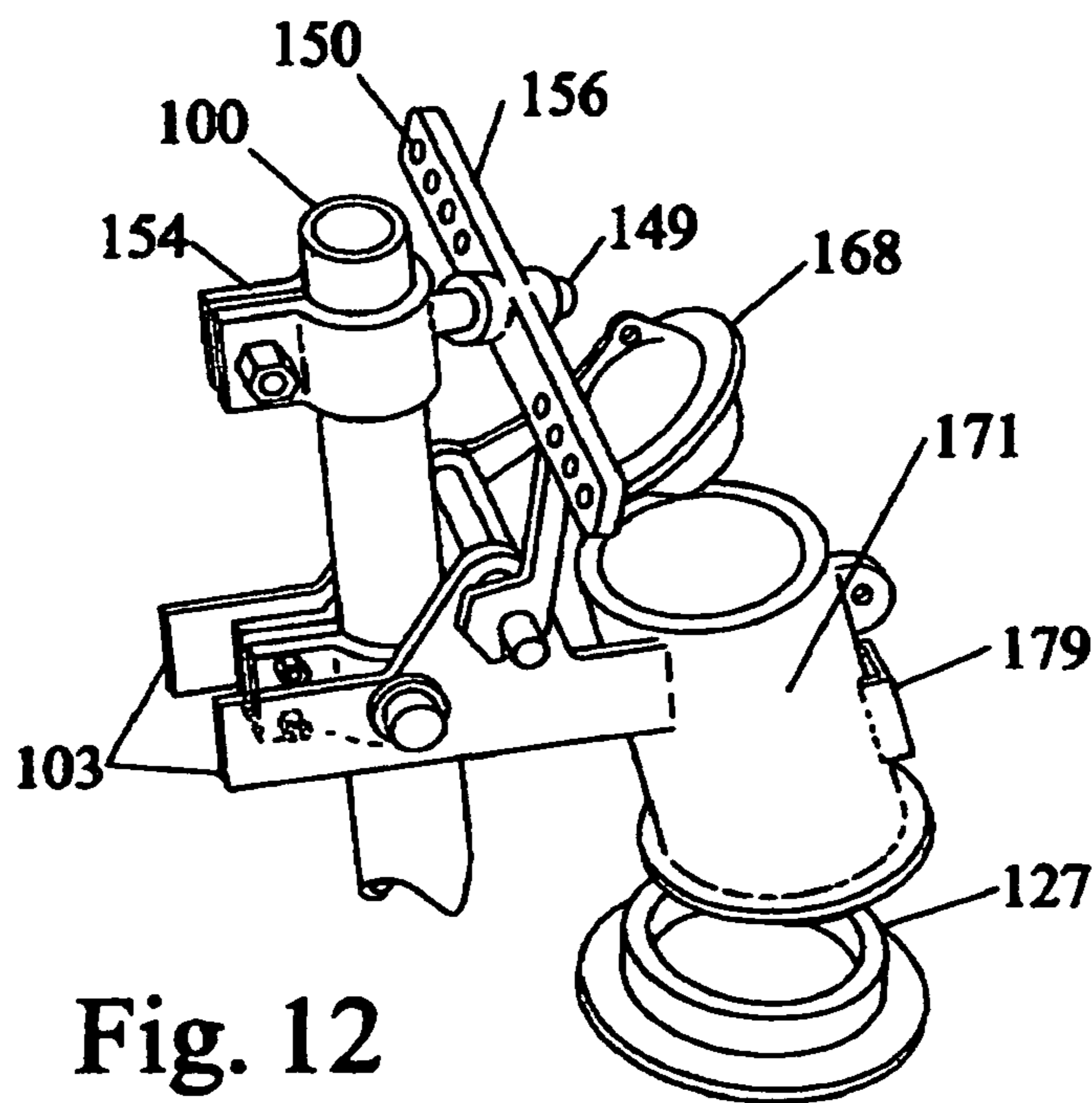

Fig. 12

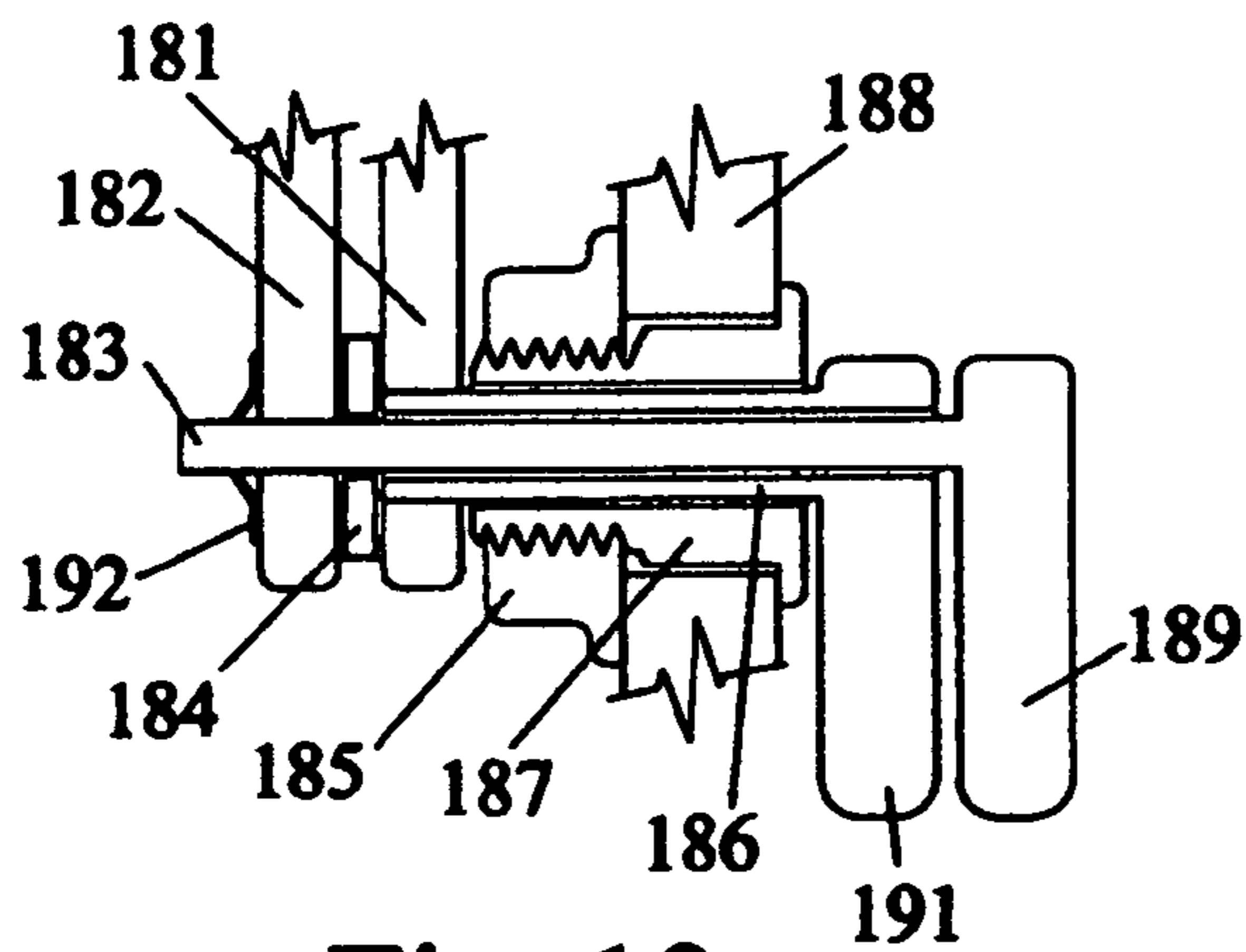

Fig. 13

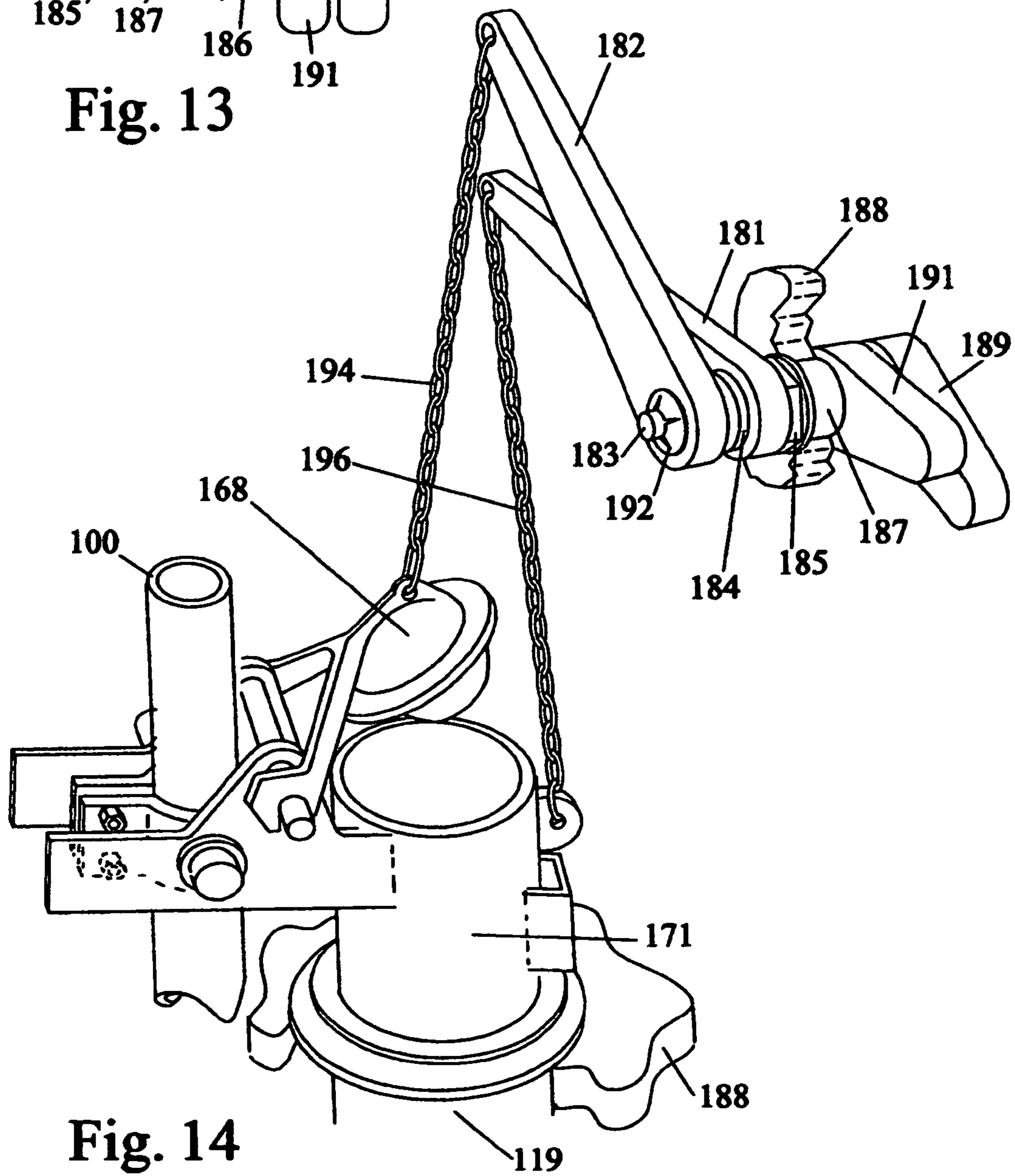
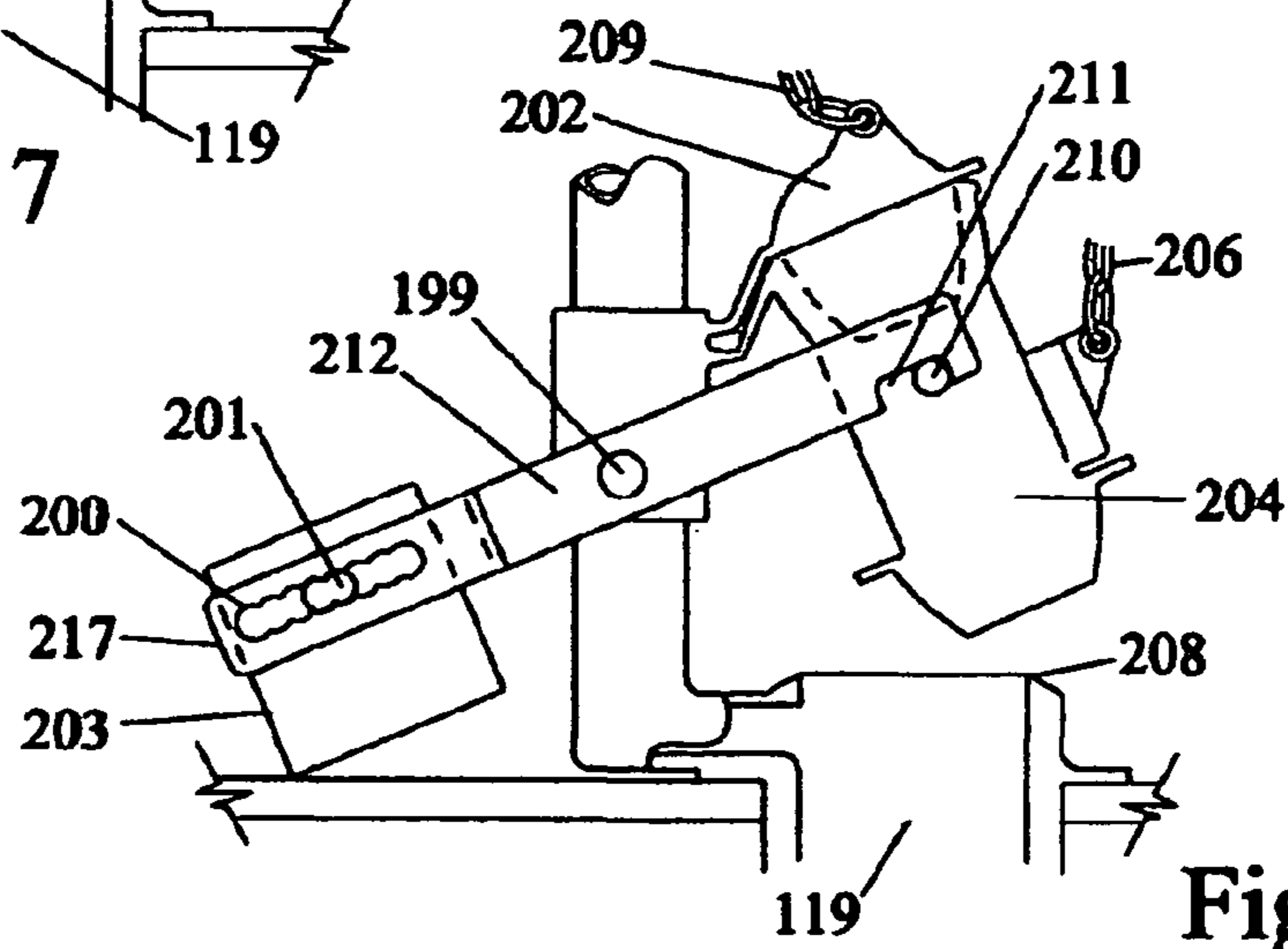
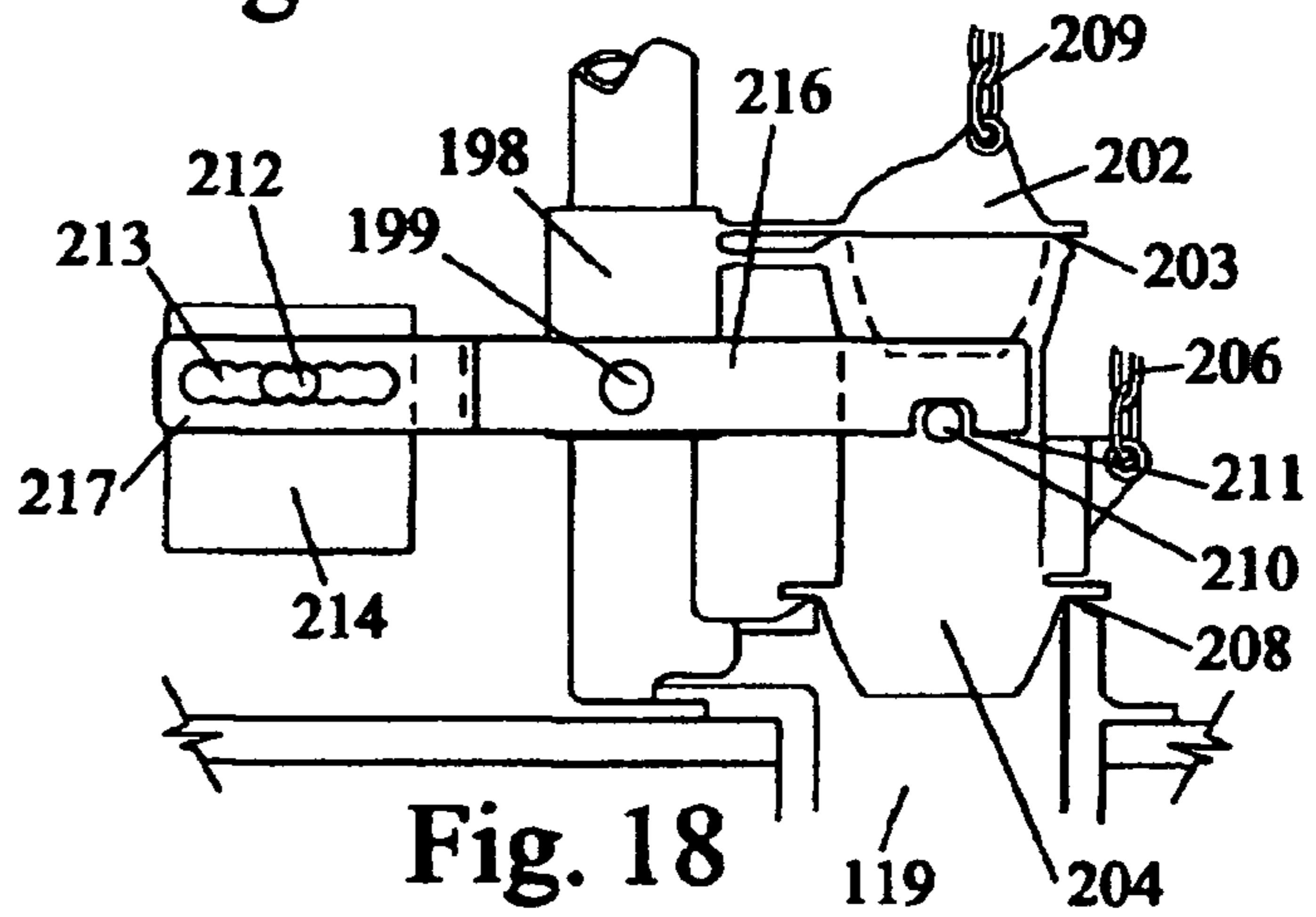
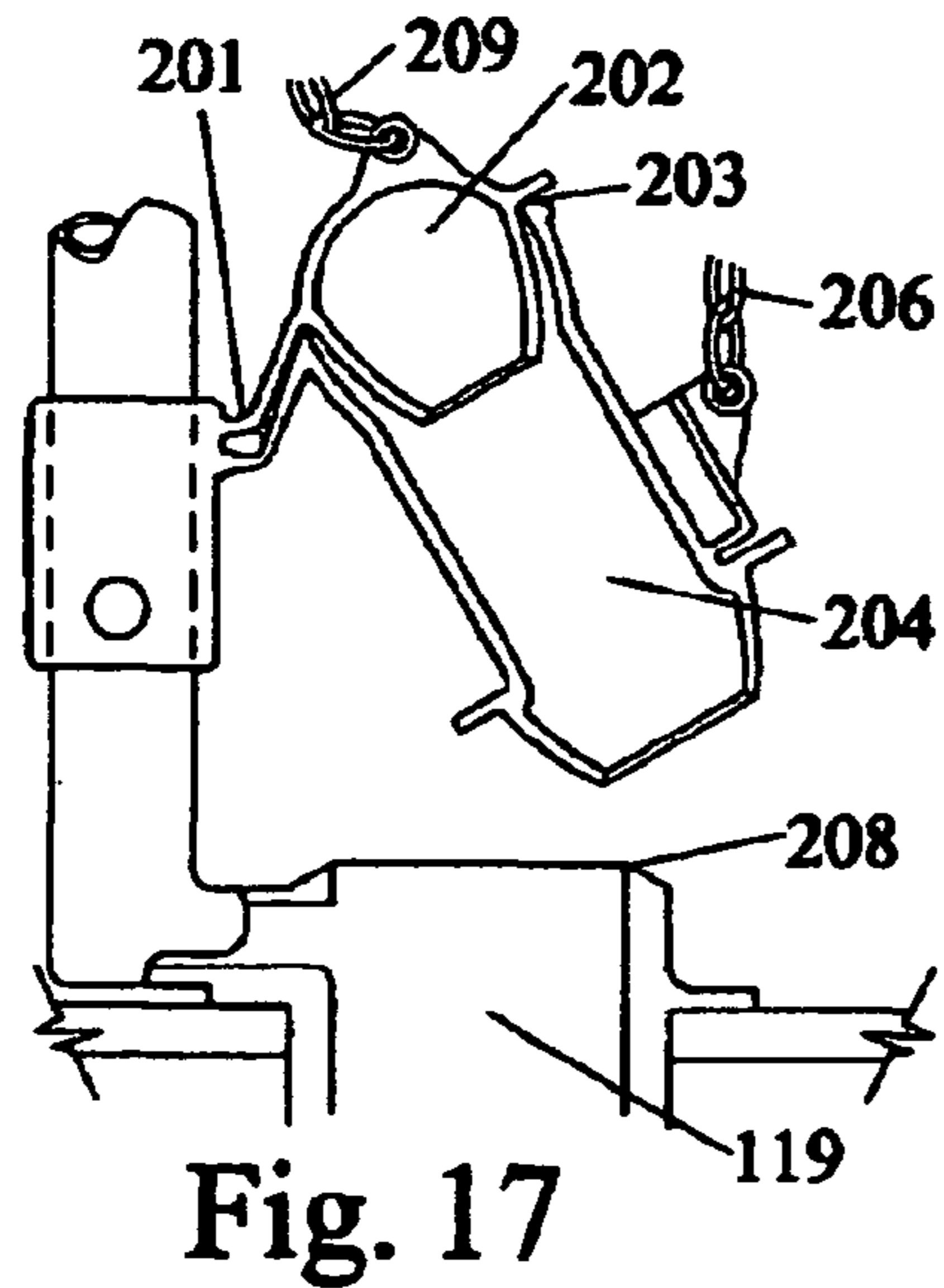
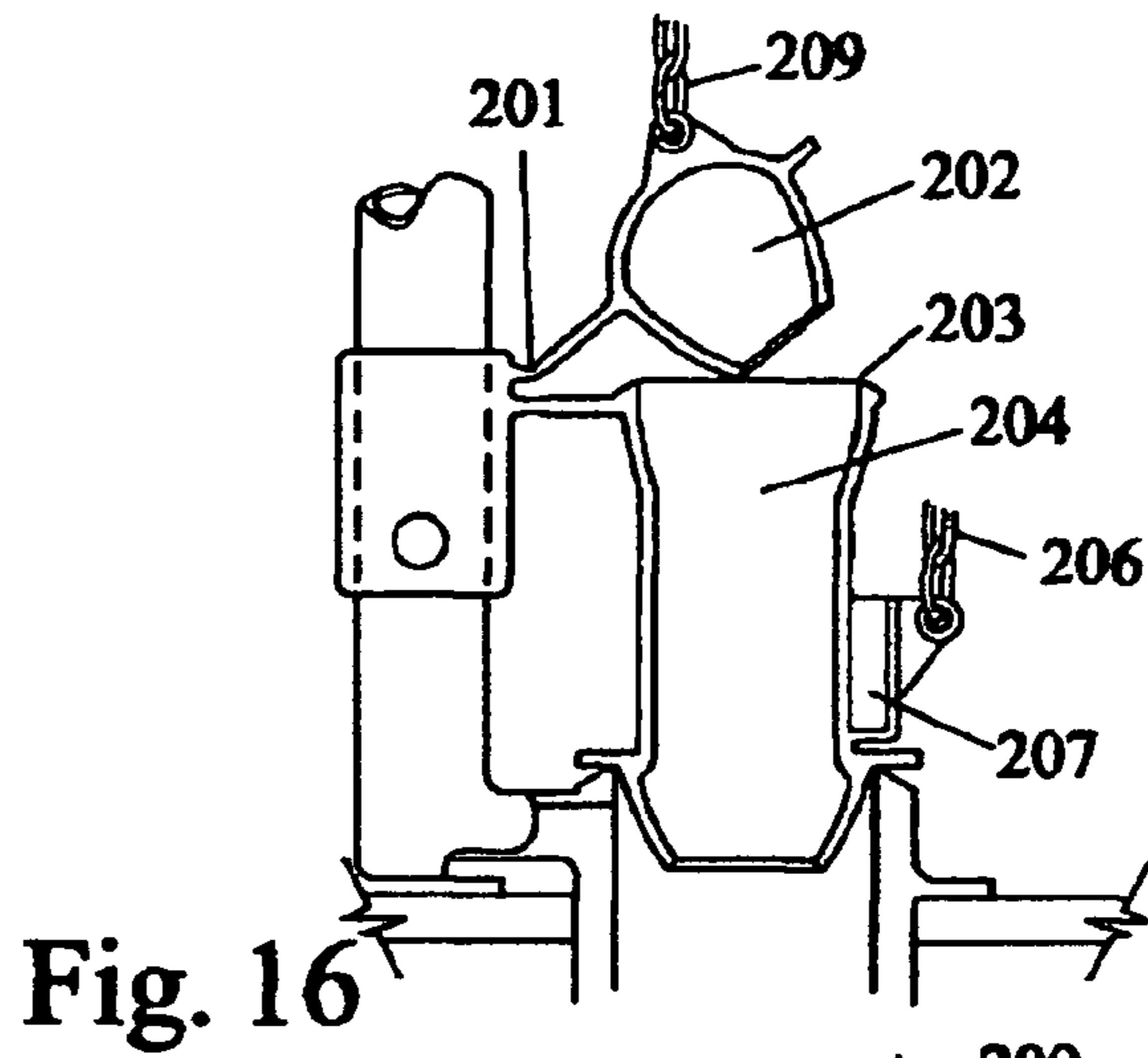
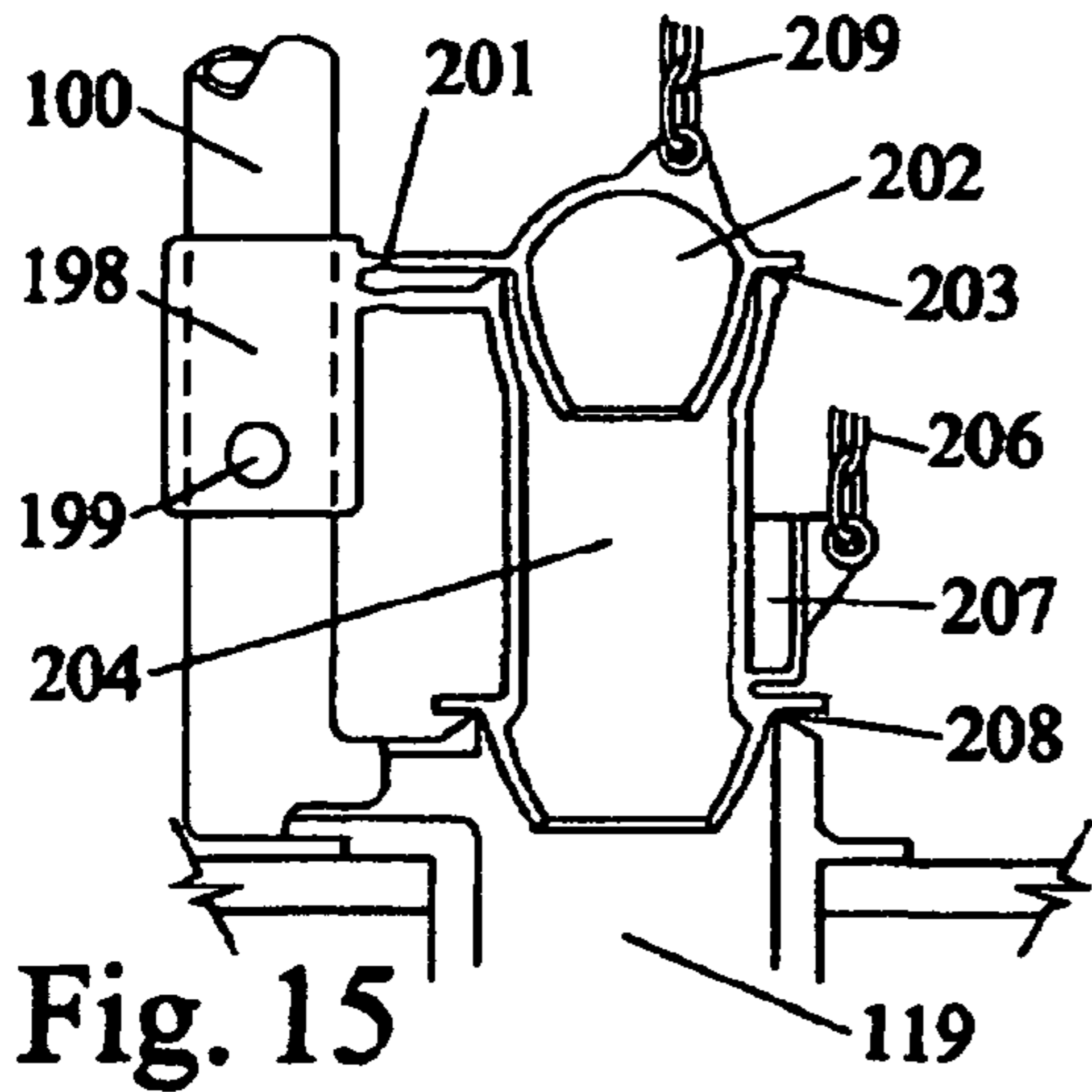

Fig. 14



1

FLUSHETTE PARTIAL AND FULL TOILET FLUSH DEVICES

Matter enclosed in heavy brackets [] appears in the original patent but forms no part of this reissue specification; matter printed in italics indicates the additions made by reissue.

CROSS-REFERENCE TO RELATED APPLICATIONS

Not Applicable

FEDERALLY SPONSORED RESEARCH

Not Applicable

SEQUENCE LISTING OR PROGRAM

Not Applicable

FIELD OF THE INVENTION

This invention relates to toilet flapper valves which can be installed as adaptor kits into existing toilets or installed as new equipment into new toilets to make such toilets capable of delivering a partial tank amount of water, or a full tank amount of water upon flushing activation.

BACKGROUND OF THE INVENTION

Currently a number of types of dual water quantity toilet flushing devices are available, but only as new toilet installations with completely new internal mechanisms or by performing a complete rebuild of the internal mechanisms in an existing type of standard or regular toilet either of which can be expensive to the average homeowner. It is obvious that a simple and easy to install and operate mechanism is needed at a low cost to provide the necessary incentives to aid in conserving our limited supply of urban water.

OBJECTS OF THE INVENTION

It is a main object of this invention to provide several types of toilet flapper valves which are simple and easy to install and operate and provide a choice of at least two different volumes of water upon flushing a toilet in which these flapper valves are installed.

It is another object of this invention to provide several types of selectable water volume flapper valves which are adjustable as to water volume delivered and can be easily substituted for parts in existing toilets.

It is an additional object of this invention to provide several types of selectable flushing water volume flapper valves which can be easily installed as new equipment in new toilets.

OPERATING PRINCIPALS AND PREFERRED EMBODIMENT

The preferred embodiment of this Flushette invention is a two section flapper valve assembly, made of a flexible, resilient material, with the lower section (herein referred to as a flapper valve discharge tube riser) being tall and hollow and approximately half the height of the maximum amount of water in the toilet tank, with the said lower section pivoting or bending about a point on a clamp-on bracket attached onto a regular type overflow tube in a currently regular type toilet

2

and acting as a flapper valve on a regular type discharge tube seat, and with an upper section consisting of a currently standard type flapper valve, sealing on the top of the flapper valve discharge tube riser lower section, with upper section arms attached to and pivoting or bending near the pivot point of the lower section arms, with either the upper flapper valve section being operated alone for a partial water volume flush or both the upper and lower flapper valve sections being operated together for a full water volume flush and with a counter balance float on the opposite end of the tall, hollow, flapper valve arms or with weight added to the front of the flapper valve discharge tube riser section to assist the flapper valve discharge tube riser section to seal firmly on its seat. An added, optional, feature is having the flapper valve discharge tube riser lower section, made to expand or contract, especially in its vertical dimension, to alter the proportion of water flushed in the partial and full flush operations, plus having the counter balance float also made to expand and contract to alter the downward pressure of the flapper valve discharge tube riser section on its seat on the top of the discharge tube.

DESCRIPTION OF FIGURES

FIG. 1 is a cross section cut-away view of a typical Flushette flapper valve assembly in a currently standard toilet tank, with a discharge tube, leading to a currently standard toilet bowl (not shown) and with a standard toilet overflow tube, with a clamp-on pivot bracket, attached, pointing out its pivot point, where arms, of an optional, two-segment, volume adjustable, flapper valve discharge tube riser section, (upper segment, and lower segment, 115) are attached and with an optional, volume adjustable float, 106, with its lower segment, 109, screwed into its upper segment for volume adjustment, having a gasket seal, 107, and lock nut, 108, and a flat grip, 111, for adjustment turning. Also shown are float attachments, 104, for attaching the optional float, 106, onto the back end, 103, of the arms, 114, of the flapper valve discharge tube riser upper segment, 125, and pivot points, 112, on the top of the flapper valve discharge tube riser arms, 114, onto which fit arms, 113, of a currently standard type flapper valve, 116, which here constitutes the upper section flapper valve, which seals, 117, on the top of the flapper valve discharge tube riser lower section, (115, lower segment, 125, upper segment). Also shown are a gasket seal, 121, between the upper, 125, and lower, 115, segments of the flapper valve discharge tube riser section and a lock nut, 122, securing the adjustment position of the two segments. Also illustrated is a weight pocket, 118, which can be used to assist the flapper valve discharge tube riser to seal on its seat, 123.

FIG. 2 is a cross section cut-away of a toilet tank with the same Flushette parts as in FIG. 1, excepting that a lengthening adjustment has been made to the lower section, the flapper valve discharge tube riser (upper segment, 125, and lower segment, 115) by extending the lower segment, 115, outward, with a re-tightening of a lock nut, 122, on a gasket seal, 121, and making a lengthening, volume increasing, adjustment to the float, 106, by way of extending its lower segment, 109, using the flap grip, 111, and re-tightening its lock nut, 108, onto its gasket seal, 107, and raising the position of the flapper valve and float assembly on the overflow tube, 100, by loosening, re-positioning and re-tightening the clamp-on bracket, 102.

FIG. 3 is a cutaway front view of a typical toilet tank, 124, showing the key elements of a typical Flushette two section flapper valve installation, with the upper section being a currently typical toilet flapper valve, 116, and the lower section

being a two-segment flapper valve discharge tube riser (lower segment, 115, upper segment, 125) with a regular type flush handle, 127, an inside actuator arm, 129, with a flapper valve chain, 134, and a flapper valve discharge tube riser chain, 133, shown, along with a regular water level float, 131, and a water level, 132. A flapper valve clamp-on bracket, 102, having a pivot, 101, fastened onto a typical toilet overflow tube, 100, and with arms, 114, of a two segment (lower segment, 115, upper segment, 125) flapper valve discharge tube riser, with arms, 114, fitted over a pivot point, 101, and on the arms, 114, are a second set of pivots, 112, made to receive the arms, 113, of a currently typical flapper valve, 116, which seals on a seat, 117, on the top segment, 125, of the flapper valve discharge tube riser, while the lower segment, 115, of the flapper valve discharge tube riser seals on a seat, 123, on a regular toilet discharge tube, 119, counter-balanced by a float, 106, or by weights added to a weight pocket, 118, on the flapper valve discharge tube riser, which is on the top of a typical toilet discharge tube, 119, and with a chain attachment point, 135, on the typical toilet flapper valve, 109, and a chain attachment point, 136, on the two segment flapper valve discharge tube riser. This arrangement of elements provides that a small amount of resistance and release can be felt in the flushing handle, 127, during a downward push when the currently typical flapper valve, 116, is lifted, causing a partial flush and when the flushing handle, 127, is pushed further downward, much more resistance and release is felt when the flapper valve discharge tube riser and the regular flapper valve are lifted together, to cause a full water volume flush of the toilet.

FIG. 4 is a cutaway front view of a toilet tank showing the same key elements of a Flushette toilet flapper valve installation as shown in FIG. 1, FIG. 2 and FIG. 3, excepting that the regular type flapper valve, 116, has been lifted off its seat, 117, on top of the upper segment, 125, of the flapper valve discharge tube riser, by a downward movement of the toilet flush handle, 127, lifting the inside actuator arm, 129, which lifts the flapper valve, 116, by way of a chain, 134, while slack on another chain, 133, is taken up, leaving the two-segment (115, lower segment and, 125, upper segment) flapper valve discharge tube riser on its seat, 123, on top of a typical toilet discharge tube, 119, which allows the water between the level, 132, in FIG. 3, and the level, 128, in this figure, to flow down through the flapper valve discharge tube riser (115, lower segment and, 125, upper segment) and through the discharge tube, 119, to the toilet bowl (not shown).

FIG. 5 is a cutaway front view of a regular toilet tank showing the same key elements of a Flushette toilet flapper valve installation as shown in FIG. 1, FIG. 2, FIG. 3 and FIG. 4, excepting that the two segment (115, lower segment 125, upper segment) flapper valve discharge tube riser section has been lifted off of its seat, 123, at the top of the discharge tube, 119, allowing the water in the toilet tank in this figure to drop, from level, 132, in FIG. 3, to the water level, 137, in this figure, which is the level of the seat, 123, and flow down the discharge tube, 119, to the toilet bowl (not shown). Note that the typical flapper valve, 116, which seals on its seat, 117, at the top of the two segment (125, upper segment, 115, lower segment) flapper valve discharge tube riser section, remains against its seat, 117, as the two segment flapper valve discharge tube riser is lifted by the inside actuator arm, 129, and the chain, 133, while the counter-balance float, 106, has dropped, because of the lift of the arm and chain and is unaffected by the drop in water level, 137.

FIG. 6 is an isometric view of a counter-balance float, 106, which is also shown as item 106 in FIG. 1, FIG. 2, FIG. 3 and FIG. 5, pointing out attachment members, 104, which fit to the ends of the arms, item 103, in FIG. 1, and FIG. 7, and also

pointing out the float volume enlargement and reduction segment, 109, (See FIG. 1 and FIG. 2, items 106, 107, 108, 109 and 111). Note that the float displacement should be approximately equal to the displacement of the flapper valve discharge tube riser and the typical flapper valve shown in other figures herein.

FIG. 7 is a cutaway side view of a typical toilet tank showing a Flushette installation where a flapper valve clamp-on bracket, 102, is attached to a regular type overflow tube, 100, with said flapper valve clamp-on bracket, 102, having a pivot, 101, onto which fit the arms, 114, (shown without counter-balance float or weights) of a single segment flapper valve discharge tube riser, 141, which seals onto a seat, 151, at the top of a discharge tube, 119, which leads to a toilet bowl (not shown) and a flapper valve pivot, 112, to which are attached arms of a regular type flapper valve, 116, which is operated by chain, 139, and seals onto a seat, 148, at the top of said single segment flapper valve discharge tube riser, 141, and seals off water flow to the discharge tube, 119, which conducts water to a toilet bowl (not shown). Note that a regular toilet flush operating handle, 142, is shown, attached to a regular inside arm, 138, with a flapper valve discharge tube riser chain, 146, having a certain amount of slack shown at its lower end, attached to the single segment flapper valve discharge tube riser, 141, and a chain, 144, attached to a typical flapper valve, 116, which fits onto and seals the top seat, 148, on the single segment flapper valve discharge tube riser, 141, and that the water level, 143, is controlled by a regular type toilet float, through a regular fill valve and fill tube, all within a toilet tank, 147. Note that a counter-balance float, such as that shown as item 106 in FIG. 1, FIG. 2, FIG. 3 and FIG. 6, is not attached to the arm ends, 103, but weights are added to the weight pocket, 149, to act as a floatation counter balance and assist the single segment flapper valve discharge tube riser, 141, to stay firmly on its seat, 151.

FIG. 8 is an isometric view of the key elements of a typical Flushette installation, such as that shown in FIG. 7, pointing out a regular toilet overflow tube, 100, a flapper valve pivot clamp-on bracket, 102, attached to the overflow tube, 100, a pivot, 101, on the flapper valve pivot clamp-on bracket, 102, over which are fitted arms, 114, of a single segment flapper valve discharge tube riser, 141, which has a seat, 148, on its top surface, onto which seals a regular type flapper valve, 116, which swings on pivots, 112, on the top of the arms, 114, of the flapper valve discharge tube riser, 141, which itself seals on a seat, 151, at the top of a toilet discharge tube, 119, which leads to a toilet bowl (not shown). Note that weights in a weight pocket, 149, substitute for a float, such as that shown in FIG. 6, which may be optionally attached to arm ends, 103.

FIG. 9 is a cutaway front view of a regular toilet tank, 159, showing another Flushette flapper valve arrangement in static, non-flushed, full toilet tank position, with water level, 166, and with a typical single segment flapper valve discharge tube riser, 171, having a regular flapper valve, 168, on its top, and having a pivot beam clamp-on bracket, 154, in addition to a flapper valve clamp-on bracket (not shown in this figure, but shown as item 102 in FIG. 8), attached to an overflow tube, 100, with a pivot beam, 156, pivoting on a pivot point, 162, and with a drive rod, 164, between an inside actuator arm, 163, and the pivot beam, 156, with a flapper valve chain, 157, to lift a typical flapper valve, 168, off of its seat, 169, which is on the top of a single segment flapper valve discharge tube riser, 171, when a toilet flushing handle, 127, is lifted upward, which lowers the end of the inside actuator arm, 163. Note that the flapper valve discharge tube riser chain, 167, goes slack (See item 167 in FIG. 10) when the outside flush handle, 127, is lifted upward and the actuator arm, 163, moves down-

5

ward, not lifting the flapper valve discharge tube riser off of its seat, **123**, and not letting water flow down the discharge tube, **119**, by way of that seat, **123**. Also shown is another typical type of commonly used toilet float, **158**, and fill tube, **161**, illustrating that the Flushette parts will adapt to most kinds of currently typical toilets. The main operating difference between the assembly shown in this figure and those shown in previous figures is that a partial flush is achieved when the toilet flushing handle, **127**, is lifted upward and a full flush is achieved when the toilet flushing handle, **127**, is pushed downward.

FIG. **10** is a cutaway front view of the same toilet tank, **159**, as in FIG. **9**, showing the Flushette assembly, excepting that the toilet flushing handle, **127**, has been actuated upward, moving the inside actuator arm, **163**, downward, which causes a drive rod, **164**, to push down one end, **172**, of a pivot beam, **156**, which pivots on a pivot point, **162**, on a pivot beam clamp-on bracket, **154**, attached to an overflow tube, **100**, causing the other end of the pivot beam, **145**, to lift upward, pulling on the flapper valve chain, **157**, which raises a typical flapper valve, **168**, off of its seat, **169**, on the top of a single segment flapper valve discharge tube riser, **171**, allowing only the water between the level of item **166**, in FIG. **9**, and the level, **173**, in this figure to flow down through the flapper valve discharge tube riser, and into the toilet discharge tube, **119**, for a partial flush, and because the water in the tank has dropped to a new water level, **173**, the float, **158**, is actuating the fill valve at the top of a fill tube, **161**, and refilling the toilet tank, **159**, from level, **173**, back up to the level shown as **166**, in FIG. **9**. Note that a second chain, **167**, attached to a single segment flapper valve discharge tube riser, **171**, is slack and not raising the single segment flapper valve discharge tube riser, **171**, off its seat, **123**, at the top of the discharge tube, **119**.

FIG. **11** is a cutaway front view of the same toilet tank as in FIG. **9** and FIG. **10**, showing the Flushette flapper valve assembly, excepting that the toilet flushing handle, **127**, has been pushed downward, moving the inside actuator arm, **163**, upward, causing a chain, **167**, to raise the single segment flapper valve discharge tube riser, **171**, off of its seat, **123**, and allowing water in the toilet tank, **159**, to flow down through the toilet tank discharge tube, **119**, creating a full flush, and a new, lower, water level, **174**, whereupon a currently standard type toilet float, **158**, actuates a fill valve at the top of a fill tube, **161**, refilling the toilet tank. Note that a rod, **164**, has lifted one end of the pivot beam, **156**, which pivots on a pivot point, **162**, on the pivot beam clamp-on bracket, **154**, attached to the typical overflow tube, **100**, slackening the chain, **157**, attached to the typical flapper valve, **168**, and that the typical flapper valve, **168**, because of the lifting of the single segment flapper valve discharge tube riser, **171**, has remained on its seat, **169**, on the top of the single segment flapper valve discharge tube riser, **171**, causing the upper, typical flapper valve, **168**, and the lower, single segment flapper valve discharge tube riser, **171**, to act together as a single flapper valve unit.

FIG. **12** is an isometric view of the key elements of a Flushette installation as illustrated in FIG. **9**, FIG. **10** and FIG. **11**, using a pivot beam clamp-on bracket, **154**, attached to a typical overflow tube, **100**, in a toilet, with the pivot beam clamp-on bracket, **154**, having a pivot point, **149**, upon which a pivot beam, **156**, with holes, **150**, is mounted to facilitate the desired actions of actuating the toilet flushing handle upward to partially flush a toilet or actuating the toilet flushing handle downward to fully flush the same toilet, as illustrated in FIG. **9**, FIG. **10** and FIG. **11**. Also illustrated are a regular type flapper valve, **168**, a single segment flapper valve discharge

6

tube riser, **171**, and its seat, **127**, at the top of a regular toilet discharge tube leading to a toilet bowl (not shown). Note that the ends, **103**, of the arms attached to the single segment flapper valve discharge tube riser, **171**, protrude in such a way as to allow the fitting of a counter-balance float, such as the one shown as item **106** in FIG. **6**, if space allows, or if there is limited space, weights are added to a weight pocket, **179**, to assist the flapper valve discharge tube riser to seal on its seat, **127**.

FIG. **13** is a cutaway view looking down on a set of dual flushing handles in the wall of a toilet, **188**, such as shown in the isometric view of FIG. **14**, with a first inside actuator arm, **181**, connected to and activated by a full flush outside handle, **191**, and a second inside actuator arm, **182**, connected to and activated by a light flush outside handle, **189**, with a spacer, **184**, between the two inside actuator arms, **181**, and **182**, and a push-on retainer, **192**, pushed onto a shaft, **183**, which runs between the light flush outside handle, **189**, and the second actuator arm, **182**, to hold the arms onto the shaft and with a nut, **185**, on a toilet tank through-hull fitting, **187**, to hold the assembly in place while a second, tubular shaft, **186**, runs between the full flush outside handle, **191**, and the first inside actuator arm, **181**.

FIG. **14** is an isometric view of a Flushette assembly mounted on an overflow tube, **100**, within a toilet tank, **188**, operated by two separate flush handles, and held in place by a through hull toilet tank fitting, **187**, a nut, **185** and a push-on retainer, **192**, with an outside light flush handle, **189**, driving a shaft, **183**, which drives a second inside actuator arm, **182**, which moves a flapper valve chain, **194**, to lift a regular type flapper valve, **168**, and a full flush outside handle, **191**, driving a tubular shaft (not visible in this view), which drives a first inside actuator arm, **181**, which moves a flapper valve discharge tube riser chain, **196**, and an attached flapper valve discharge tube riser, **171**, on a toilet discharge tube, **119**, with a spacer, **184**, between the two inside actuator arms, **181**, and **182**. Actuating only the outside light flush handle, **189**, initiates a partial, or light, flush amount of water, while actuating both outside handles together or the full flush outside handle, **191**, alone initiates a full flush amount of water.

FIG. **15** is a cutaway view of a Flushette device molded as a single flexible, resilient piece with a mounting bracket, **198**, having round, shaft like protrusions, **199**, on each side, fitted over a toilet overflow tube, **100**, with flex sections, **201**, in the arm holding an upper flapper valve section, **202**, and a lower flapper valve discharge tube riser section, **204**, which has a seat at its top, **203**, onto which seals the upper flapper valve section, **202**, and with the flapper valve discharge tube riser section, **204**, sealing on a seat, **208**, at the top of a toilet discharge tube, **119**. Also shown are an upper flapper valve activating chain, **209**, and a flapper valve discharge tube riser activating chain, **206**, along with a weights pocket, **207**, for holding counter balance weights to assist the flapper valve discharge tube riser, **204**, to stay firmly on its seat, **208**.

FIG. **16** is a cutaway view of a similar single piece flexible, resilient Flushette device as shown in FIG. **15**, with a flex point, **201**, a chain, **209**, an upper flapper valve section, **202**, a seat, **203**, at the top of a flapper valve discharge tube riser, **204**, with a chain, **206**, attached just above a weight pocket, **207**, excepting that the upper flapper valve chain, **209**, has been activated to lift the flapper valve section, **202**, to allow water to flow down through the flapper valve discharge tube riser section, **204**, and into a toilet bowl (not shown).

FIG. **17** is a similar single piece flexible, resilient Flushette device as those shown in FIG. **15** and FIG. **16**, except that the chain, **206**, has lifted the tall hollow flapper valve, **204**, off of its seat, **208**, causing bending at the flex point, **201**, and

slackening the upper flapper valve chain, 209, which leaves the upper flapper valve section, 202, on its seat, 203, at the top of the flapper valve discharge tube riser section, 204, which allows water to flow down over the seat, 208, and into a toilet bowl (not shown) by way of the toilet discharge tube, 119.

FIG. 18 is a side view of a single piece, molded, flexible, resilient Flushette device, similar to those shown in FIG. 15, FIG. 16, and FIG. 17, excepting that a counter balance float, 214, has been added to the assembly, on a mounting bracket, 198, having round protrusions, 199, on its sides over which are fitted arms, 216, which extend out and become a yoke, 217, having slots, 213, on both yoke arms, with interferences along the edges of the slots, into which are fitted double round, near figure eight shaped protrusions, 212, extending from the sides of the float, 214, with notches, 211, in the arms, 216, at the opposite end from the float, 214, and protrusions, 210, on the sides of the flapper valve discharge tube riser, 204, for the purpose of transferring the upward pressure from the float, 214, through the pivot point, 199, and onto the flapper valve discharge tube riser, 204, as the float, 214, tries to rise in water and the arms, 216, pivot on the round protrusions, 199, on the mounting bracket, 198. Note that the double round, near figure eight shaped protrusions, 212, on the float, 214, and the interferences in the slots, 213, in the yoke, 217, provide means to make adjustment to floatation pressure to counter balance the flapper valve discharge tube riser section, 204, and assist in keeping it on its seat, 208. Also shown are a chain, 209, on the upper flapper valve, 202, the upper flapper valve seat, 203, on the top of the flapper valve discharge tube riser, 204, another chain, 206, on the flapper valve discharge tube riser, 204, and a toilet discharge tube, 119, leading to a toilet bowl (not shown).

FIG. 19 is a side view of a single piece flexible, resilient Flushette device as shown in FIG. 18, excepting that the flapper valve discharge tube riser section, 204, of the device has been lifted by its chain, 206, also lifting the upper flapper valve, 202, by its position on the top of the flapper valve discharge tube riser section, 204, with its chain, 209, going slack and adding weight to assist in keeping the upper flapper valve section, 202, seated on top of the flapper valve discharge tube riser section, 204, while the float, 203, is pushed downward and exerts pressure upward by its tendency to float, putting pressure through the double round near figure eight protrusions, 201, on the sides of the float and into the yoke, 217, and the arms, 212, through the pivots, 199, to the notches, 211, and the protrusions, 210, on the sides of the flapper valve discharge tube riser section, 204, tending to push it back down onto its seat, 208, on the toilet discharge tube, 119. Also note that the flapper valve discharge tube riser section, 204, and the upper flapper valve section, 202, act together as a single flapper valve, and being raised off of the seat, 208, at the top of the toilet discharge tube, 119, allows a full tank of water to flow down the toilet discharge tube, 119, and into a toilet bowl (not shown). Note that lifting only the upper flapper valve chain, 209, without lifting the flapper valve discharge tube riser chain, 206, allows only a partial tank of water to flow down through the flapper valve dis-

charge tube riser, 204, and through the toilet discharge tube, 119, and into a toilet bowl (not shown).

I claim:

5 [1. A dual flush flapper valve apparatus comprising; a lower hollow segment having an upper open top and an open bottom, said open bottom adapted to seal a valve seat of a known toilet discharge tube, an upper segment engaged with said open top of said lower segment, a clamp on pivot bracket adapted to receive and be clamped onto a standpipe of a known toilet discharge outlet, said upper segment being pivotally attached to said bracket to allow swinging movement of said upper and lower segments between a sealing and a non-sealing disposition with respect to said toilet discharge tube, said upper segment having an open top forming a valve seat adapted to receive a conventional flapper valve in sealing engagement therewith, an adjustable float cantilevered to said bracket on a side opposite to said upper and lower segments, said adjustable float comprising a lower portion adjustably attached to an upper portion, said bracket having pivot points thereon to accept pivot arms of a conventional flapper valve.]

[2. A dual flush toilet flapper valve as in claim 1, having a pocket into which can be placed weights to help hold the flapper valve segments on the toilet discharge tube.]

3. A dual flush flapper valve apparatus comprising:

a riser segment comprising a lower hollow segment having an upper open top and an open bottom, said open bottom adapted to seal a valve seat of a known toilet discharge tube and an upper segment engaged with said open top of said lower segment, said upper segment having an open top forming a valve seat adapted to receive a conventional flapper valve in sealing engagement therewith,

a clamp on pivot bracket adapted to receive and be clamped unto a standpipe of a known toilet discharge outlet, said upper segment being pivotally attached to said bracket to allow swinging movement of said upper and lower segments between a sealing and non-sealing disposition with respect to said toilet discharge tube, said bracket having pivot points to accept pivot arms of said conventional flapper valve, and an adjustable float cantilevered to said bracket on a side opposite to said upper and lower segments, said adjustable float comprising a lower portion adjustably attached to an upper portion.

4. A dual flush toilet flapper valve as in claim 3, having a pocket into which can be placed weights to help hold the flapper valve segments on the toilet discharge tube.

5. A dual flush toilet discharge valve apparatus as in claim 3, having an adjustable float cantilevered to said bracket on a side opposite to said riser segment, said adjustable float comprising a lower portion adjustably attached to an upper portion.

6. A dual flush toilet discharge valve apparatus as in claim 3, having a pocket into which can be placed weights to help hold the valve segments on the toilet discharge tube.

* * * * *