

US00RE44723E

(19) **United States**
(12) **Reissued Patent**
Keshav et al.

(10) **Patent Number:** **US RE44,723 E**
(45) **Date of Reissued Patent:** **Jan. 21, 2014**

(54) **REGULATING FILE ACCESS RATES ACCORDING TO FILE TYPE**
(75) Inventors: **Srinivasan Keshav**, Waterloo (CA); **Rosen Sharma**, Mountain View, CA (US)
(73) Assignee: **Digital Asset Enterprises, L.L.C.**, Wilmington, DE (US)

5,325,530 A 6/1994 Mohrmann
5,437,032 A 7/1995 Wolf et al.
5,528,753 A 6/1996 Fortin
5,566,334 A 10/1996 Loader
5,572,680 A 11/1996 Ikeda et al.
5,584,023 A 12/1996 Hsu
5,603,020 A 2/1997 Hashimoto et al.
5,615,400 A 3/1997 Cowsar et al.
5,623,492 A 4/1997 Teraslinna

(Continued)

(21) Appl. No.: **11/818,544**

FOREIGN PATENT DOCUMENTS

(22) Filed: **Jun. 14, 2007**
(Under 37 CFR 1.47)

JP 64-002145 1/1989
WO WO 99/39261 8/1999
WO WO-9939261 A1 8/1999

Related U.S. Patent Documents

Reissue of:

(64) Patent No.: **6,907,421**
Issued: **Jun. 14, 2005**
Appl. No.: **09/572,672**
Filed: **May 16, 2000**

OTHER PUBLICATIONS

Keshav, S., *An Engineering Approach to Computer Networking: ATM Networks, the Internet, and the Telephone Network*, Reading, MA, Addison-Wesley, 1997, pp. vii-xi, 85-115, 209-355, 395-444.

(Continued)

(51) **Int. Cl.**
G06F 17/30 (2006.01)
G06F 15/16 (2006.01)

Primary Examiner — Apu Mofiz
Assistant Examiner — Chelcie Daye
(74) *Attorney, Agent, or Firm* — Perkins Coie LLP

(52) **U.S. Cl.**
USPC **707/713; 709/249**

(58) **Field of Classification Search**
USPC **707/713, 781, 1, 2; 709/249**
See application file for complete search history.

(57) **ABSTRACT**

File access rates of processes are regulated according to file type. An association table stores entries associating processes to be regulated with specific access rates for various file types. System calls that access files are intercepted, and a system call wrapper executes. The system call wrapper determines the type of file that is being accessed by the process. The system call wrapper examines the association table in order to determine if the calling process is associated with an access rate for the file type being accessed. If so, the system call wrapper regulates access to the file according to the appropriate rate.

(56) **References Cited**

U.S. PATENT DOCUMENTS

3,377,624 A 4/1968 Nelson et al.
4,177,510 A 12/1979 Appell et al.
5,189,667 A 2/1993 Esaki et al.
5,212,793 A 5/1993 Donica et al.
5,226,160 A 7/1993 Waldron et al.
5,249,290 A 9/1993 Heizer
5,263,147 A 11/1993 Francisco et al.
5,279,039 A 1/1994 Anderson et al.

21 Claims, 5 Drawing Sheets

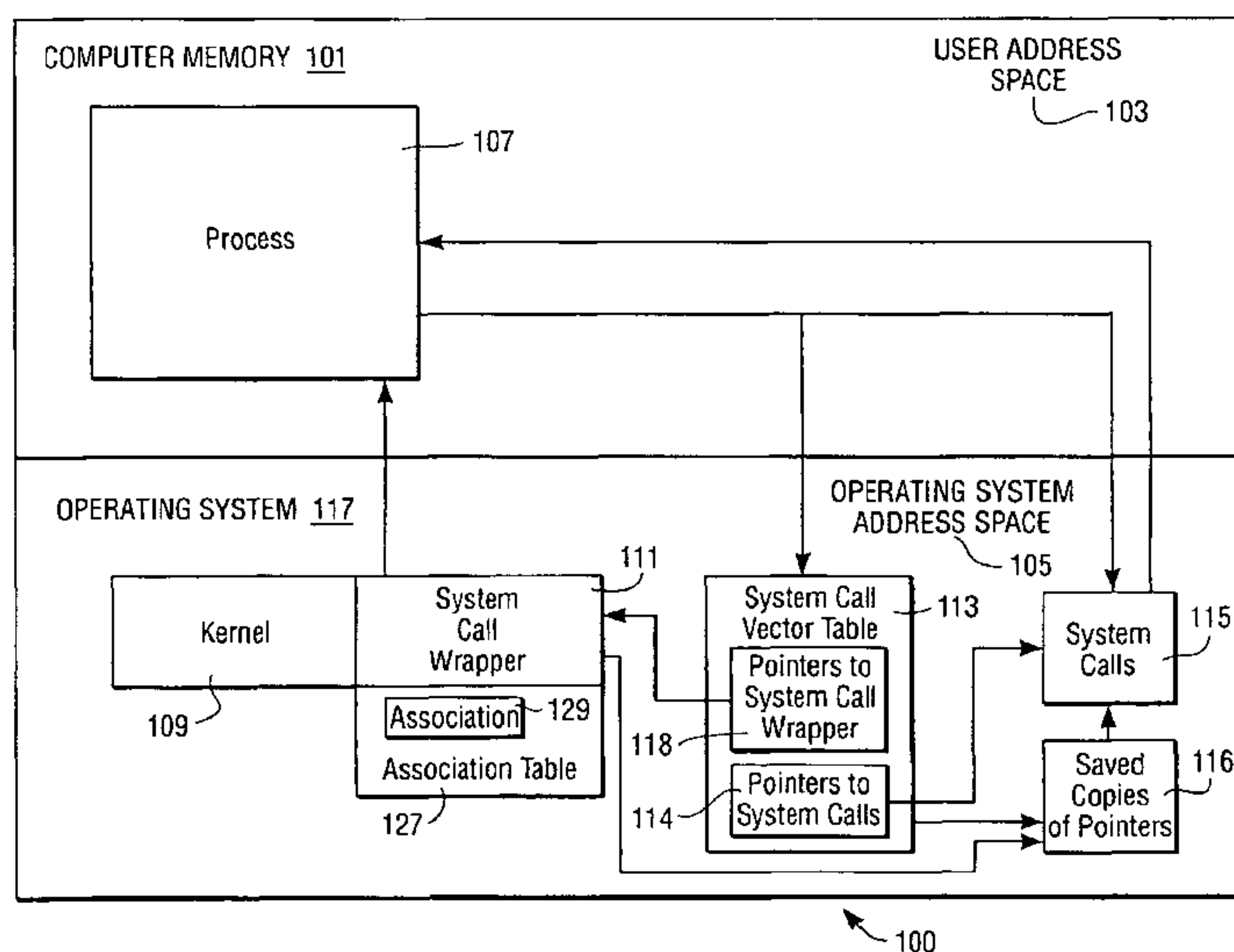

(56)

References Cited

U.S. PATENT DOCUMENTS

5,636,371 A	6/1997	Yu	6,189,046 B1	2/2001	Moore et al.
5,640,595 A	6/1997	Baugher et al.	6,192,389 B1	2/2001	Ault et al.
5,692,047 A	11/1997	McManis	6,192,512 B1	2/2001	Chess
5,706,097 A	1/1998	Schelling et al.	6,230,203 B1	5/2001	Koperda et al.
5,706,453 A	1/1998	Cheng et al.	6,240,463 B1	5/2001	Benmohamed et al.
5,708,774 A	1/1998	Boden	6,243,825 B1	6/2001	Gamache et al.
5,719,854 A	2/1998	Choudhury et al.	6,247,057 B1	6/2001	Barrera, III
5,727,147 A	3/1998	Van Hoff	6,247,068 B1	6/2001	Kyle
5,727,203 A	3/1998	Hapner et al.	6,259,699 B1	7/2001	Opalka et al.
5,742,772 A	4/1998	Sreenan	6,266,678 B1 *	7/2001	McDevitt et al. 707/201
5,748,614 A	5/1998	Wallmeier	6,269,404 B1	7/2001	Hart et al.
5,752,003 A	5/1998	Hart	6,279,039 B1	8/2001	Bhat et al.
5,761,477 A	6/1998	Wahbe et al.	6,279,040 B1	8/2001	Ma et al.
5,764,889 A	6/1998	Ault et al.	6,282,581 B1	8/2001	Moore et al.
5,781,550 A	7/1998	Templin et al.	6,282,703 B1	8/2001	Meth et al.
5,799,173 A	8/1998	Gossler et al.	6,286,047 B1	9/2001	Ramanathan et al.
5,809,527 A	9/1998	Cooper et al.	6,298,479 B1	10/2001	Chessin et al.
5,828,893 A	10/1998	Weid et al.	6,308,216 B1	10/2001	Goldszmidt et al.
5,838,686 A	11/1998	Ozkan	6,314,558 B1	11/2001	Angel et al.
5,838,916 A	11/1998	Domenikos et al.	6,327,622 B1	12/2001	Jindal et al.
5,842,002 A	11/1998	Schnurer et al.	6,336,138 B1	1/2002	Caswell et al.
5,845,129 A	12/1998	Wendorf et al.	6,351,775 B1	2/2002	Yu
5,850,399 A	12/1998	Ganmukhi et al.	6,353,616 B1	3/2002	Elwalid et al.
5,860,004 A	1/1999	Fowler et al.	6,363,053 B1	3/2002	Schuster et al.
5,864,683 A *	1/1999	Boebert et al. 709/249	6,366,958 B1	4/2002	Ainsworth et al.
5,889,956 A	3/1999	Hauser et al.	6,370,583 B1	4/2002	Fishler et al.
5,889,996 A	3/1999	Adams	6,374,292 B1	4/2002	Srivastava et al.
5,892,968 A	4/1999	Iwasaki et al.	6,381,228 B1	4/2002	Prieto, Jr. et al.
5,905,730 A	5/1999	Yang et al.	6,385,638 B1	5/2002	Baker-Harvey
5,905,859 A	5/1999	Holloway et al.	6,385,722 B1	5/2002	Connelly et al.
5,913,024 A	6/1999	Green et al.	6,389,448 B1	5/2002	Primak et al.
5,915,085 A	6/1999	Koved	6,393,484 B1	5/2002	Massarani
5,915,095 A	6/1999	Miskowiec	6,425,003 B1	7/2002	Herzog et al.
5,918,018 A	6/1999	Gooderum et al.	6,430,622 B1	8/2002	Aiken, Jr. et al.
5,920,699 A	7/1999	Bare	6,434,631 B1	8/2002	Bruno et al.
5,933,603 A	8/1999	Vahalia et al.	6,434,742 B1	8/2002	Koepele, Jr.
5,937,159 A	8/1999	Meyers et al.	6,438,134 B1	8/2002	Chow et al.
5,944,795 A	8/1999	Civanlar	6,442,164 B1	8/2002	Wu
5,953,685 A *	9/1999	Bogin et al. 702/136	6,449,647 B1	9/2002	Colby et al.
5,956,481 A	9/1999	Walsh et al.	6,449,652 B1	9/2002	Blumenau et al.
5,961,582 A	10/1999	Gaines	6,457,008 B1	9/2002	Rhee et al.
5,961,583 A	10/1999	Van Fleet	6,463,454 B1	10/2002	Lumelsky et al.
5,978,373 A	11/1999	Hoff et al.	6,463,459 B1	10/2002	Orr et al.
5,982,748 A	11/1999	Yin et al.	6,466,985 B1	10/2002	Goyal et al.
5,987,242 A	11/1999	Bentley et al.	6,470,398 B1	10/2002	Zargham et al.
5,987,524 A	11/1999	Yoshida et al.	6,484,173 B1	11/2002	O'Hare et al.
5,987,608 A	11/1999	Roskind	6,487,578 B2	11/2002	Ranganathan
5,991,812 A	11/1999	Srinivasan	6,487,663 B1	11/2002	Jaisimha et al.
5,999,963 A	12/1999	Bruno et al.	6,490,670 B1	12/2002	Collins et al.
6,016,318 A	1/2000	Tomoike	6,496,847 B1	12/2002	Bugnion et al.
6,018,527 A	1/2000	Yin et al.	6,499,137 B1	12/2002	Hunt
6,023,721 A	2/2000	Cummings	6,499,652 B1	12/2002	Flynn et al.
6,038,608 A	3/2000	Katsumnata	6,529,950 B1	3/2003	Lumelsky et al.
6,038,609 A	3/2000	Geulen	6,529,985 B1	3/2003	Deianov et al.
6,047,325 A	4/2000	Jain et al.	6,542,167 B1	4/2003	Darlet et al.
6,055,617 A	4/2000	Kingsbury	6,553,413 B1	4/2003	Leughton et al.
6,055,637 A	4/2000	Hudson et al.	6,560,613 B1	5/2003	Gylfason et al.
6,061,349 A	5/2000	Coile et al.	6,578,055 B1	6/2003	Hutchison et al.
6,065,118 A	5/2000	Bull et al.	6,578,068 B1	6/2003	Bowman-Amuah
6,075,791 A	6/2000	Chiussi et al.	6,580,721 B1	6/2003	Beshai
6,075,938 A	6/2000	Bugnion et al.	6,590,588 B2	7/2003	Lincke et al.
6,078,929 A	6/2000	Rao	6,622,159 B1	9/2003	Chao et al.
6,078,957 A	6/2000	Adelman et al.	6,647,422 B2	11/2003	Wesinger et al.
6,086,623 A	7/2000	Broome et al.	6,658,571 B1	12/2003	O'Brien et al.
6,092,178 A	7/2000	Jindal et al.	6,691,312 B1	2/2004	Sen et al.
6,094,674 A	7/2000	Hattori et al.	6,711,607 B1	3/2004	Goyal
6,101,543 A	8/2000	Alden et al.	6,723,568 B1	4/2004	Liu et al.
6,108,701 A	8/2000	Davies et al.	6,725,456 B1	4/2004	Bruno et al.
6,108,759 A	8/2000	Orcutt et al.	6,732,211 B1	5/2004	Goyal et al.
6,122,673 A	9/2000	Basak et al.	6,754,716 B1	6/2004	Sharma et al.
6,154,776 A	11/2000	Martin	6,760,775 B1	7/2004	Anerousis et al.
6,154,778 A	11/2000	Koistinen et al.	6,779,016 B1	8/2004	Aziz et al.
6,161,139 A	12/2000	Win et al.	6,785,728 B1	8/2004	Schneider et al.
6,167,520 A	12/2000	Touboul	6,820,117 B1	11/2004	Johnson
6,172,981 B1	1/2001	Cox et al.	6,859,835 B1	2/2005	Hipp
			6,907,421 B1	6/2005	Keshav et al.
			6,909,691 B1	6/2005	Goyal et al.
			6,912,590 B1	6/2005	Lundback et al.
			6,948,003 B1	9/2005	Newman et al.

(56)

References Cited

U.S. PATENT DOCUMENTS

6,968,389	B1	11/2005	Menditto et al.
6,976,258	B1	12/2005	Goyal et al.
6,981,029	B1	12/2005	Menditto et al.
6,985,937	B1	1/2006	Keshav et al.
7,117,354	B1	10/2006	Browning et al.
7,143,024	B1	11/2006	Goyal et al.
7,219,354	B1	5/2007	Huang et al.
7,343,421	B1	3/2008	Goyal
RE42,214	E	3/2011	Goyal et al.
2003/0061338	A1	3/2003	Stelliga

OTHER PUBLICATIONS

Stevens, R. W., *Unix Network Programming vol. 1 Networking APIs: Sockets and XTI*, Upper Saddle River, NJ, Prentice Hall, 1998, pp. v-xiv, 29-53, 85-110, 727-760.

Tanenbaum, A. S. and Woodhull, A. S., *Operating Systems: Design and Implementation*, Upper Saddle River, NJ, Prentice Hall, 1997, pp. vii-xiv, 1-46, 401-454.

Rubini, A., *Linux Device Drivers*, Sebastopol, CA, O'Reilly & Associates, Inc., 1998, pp. v-x, 13-40.

Goyal, P., et al., "A Hierarchical CPU Scheduler for Multimedia Operating Systems," *Proceedings of the Second Symposium on Operating Systems Design and Implementations (OSDI'96)*, Seattle, WA, Oct. 1996, 15 pages.

Laurie, B. and Laurie, P., *Apache The Definitive Guide*, Sebastopol, CA, O'Reilly & Associates, Inc., Feb. 1999, pp. v-viii, 43-74.

Aho, A. V. and Ullman J. D., *Principles of Compiler Design*, Reading, MA, 1977, pp. vii-x, 359-362, 519-522.

Jonsson, J., "Exploring the Importance of Preprocessing Operations in Real-Time Multiprocessor Scheduling," *Proc. of the IEEE Real-Time Systems Symposium—Work-in-Progress session*, San Francisco, CA, Dec. 4, 1997, pp. 31-34.

Rusling, D. A., *Processes*, [online], [retrieved on Dec. 7, 1999]. Retrieved from the Internet: URL: <http://www.ceba.gov/about.saw/linux/tlk-html/node44.htm>.

Rusling, D. A., *Linux Processes*, [online], [retrieved on Dec. 7, 1999]. Retrieved from the Internet: URL: <http://www.ceba.gov/about.saw/linux/tlk-html/node45.html>.

Rusling, D. A., *Identifiers*, [online], [retrieved on Dec. 7, 1999]. Retrieved from the Internet: URL: <http://www.ceba.gov/about.saw/linux/tlk-html/node46.html>.

Rusling, D. A., *Scheduling*, [online], [retrieved on Dec. 7, 1999]. Retrieved from the Internet: URL: <http://www.ceba.gov/about.saw/linux/tlk-html/node47.html>.

Rusling, D. A., *Scheduling in Multiprocessor Systems*, [online], [retrieved on Dec. 7, 1999]. Retrieved from the Internet: URL: <http://www.ceba.gov/about.saw/linux/tlk-html/node48.html>.

Rusling, D. A., *Files*, [online], [retrieved on Dec. 7, 1999]. Retrieved from the Internet: URL: <http://www.ceba.gov/about.saw/linux/tlk-html/node49.html>.

Goyal, P. et al., "Start-time Fair Queuing: A Scheduling Algorithm for Integrated Services Packet Switching Networks," *Proceedings of ACM SIGCOMM '96*, San Francisco, CA, Aug. 1996, 14 pages.

Janosi, T., "Notes on 'A Hierarchical CPU Scheduler for Multimedia Operating Systems' by Pawan Goyal, Xingang Guo and Harrick Vin," [online], [retrieved on May 8, 2000]. Retrieved from the Internet: URL: <http://cs.cornell.edu/Info/Courses/Spring-97/CS614/goy.htm>.

Goyal, P., "Packet Scheduling Algorithms for Integrated Services Networks," PhD Dissertation, University of Texas, Austin, TX, Aug. 1997.

Boehm, B., "Managing Software Productivity and Reuse," *IEEE Computer*, vol. 32, No. 9, Sep. 1999, 3 pages.

Corbato, F. J. et al. "An Experimental Timesharing System," *Proceedings of the American Federation of Information Processing Societies Spring Joint Computer Conference*, San Francisco, CA, May 1-3, 1962, pp. 335-344.

Deutsch, P. and Grant, C.A., "A Flexible Measurement Tool for Software Systems," *Information Processing 71 (Proc. of the IFIP Congress)*, 1971, pp. 320-326.

Edijali, G., et al., "History-based Access Control for Mobile Code," *Fifth ACM Conference on Computer and Communication Security*, Nov. 3-5, 1998, 19 pages.

Erlingsson, U. and Schneider, F. B., "SASI Enforcement of Security Policies: A Retrospective," *Proc. New Security Paradigms Workshop*, Apr. 2, 1999, pp. 1-17.

Erlingsson, U. and Schneider, F. B., *IRM Enforcement of Java Stack Inspection*, [online], Feb. 19, 2000, [retrieved on Apr. 2, 2002]. Retrieved from the Internet: URL: <http://cs-tr.cs.cornell.edu/Dienst/UI2.0/ShowPage/ncstrl.cornell/TR2000-1786>.

Evans, D. and Twyman, A., "Flexible Policy-Directed Code Safety," *Proc. of 1999 IEEE Symposium on Security and Privacy*, Oakland, CA, May 9-12, 1999, pp. 1-14.

Fraser, T. et al., "Hardening COTS Software with Generic Software Wrappers," *Proc. of 1999 IEEE Symposium on Security and Privacy*, 1999, 15 pages.

Goldberg, I. et al., "A Secure Environment for Untrusted Helper Applications (Confining the Wily Hacker)," *Proc. of the Sixth Usenix Unix Security Symposium*, San Jose, CA, Jul. 1996, 14 pages.

Goldberg, R. P., "Survey of Virtual Machine Research," *IEEE Computer*, Jun. 1974, pp. 34-45.

Pandey, R. and Hashii, B., "Providing Fine-Grained Access Control for Mobile Programs Through Binary Editing," *Technical Report TR98 08*, University of California, Davis, CA, 1998, pp. 1-22.

Ritchie, D. M., "The Evolution of the Unix Time-Sharing System," *AT&T Bell Laboratories Technical Journal* 63, No. 6, Part 2, Oct. 1984, (originally printed 1979), 11 pages.

Saltzer, J., H. and Schroeder, M. D., *The Protection of Information in Computer Systems*, [online], 1973, [retrieved on Apr. 2, 2002]. Retrieved from the Internet: URL: <http://www.cs.virginia.edu/about.evans/cs551/saltzer>.

Wahbe, R., et al., "Efficient Software-Based Fault Isolation," *Proc. of the Symposium on Operating System Principles*, 1993, 14 pages.

Plummer, D. C., *An Ethernet Address Resolution Protocol—or—Converting Network Protocol Addresses to 48.bit Ethernet Address for Transmission on Ethernet Hardware*, Nov. 1982, [online], [retrieved on Jan. 17, 2000]. Retrieved from the Internet: URL: <http://www.msg.net/kadow/answers/extras/rfc/rfc826.tx>.

Huang, X. W. et al., "The Entrapid Protocol Development Environment," *Proceedings of IEEE Infocom'99*, Mar. 1999, 9 pages.

Duffield, N.G., et al., "A Flexible Model for Resource Management in Virtual Private Networks," *Computer Communication Review Conference, Computer Communication, ACM SIGCOMM '99 Conference*, Cambridge, MA, Aug. 30, 1999-Sep. 3, 1999, pp. 95-108.

Campbell, A. T. and Keshav, S., "Quality of Service in Distributed Systems," *Computer Communications* 21, 1998, pp. 291-293.

Bach, M. J., *The Design of the Unix® Operating System*, New Delhi, Prentice-Hall of India, 1989, pp. v-x, 19-37.

McDougall, R., et al., "Resource Management," Upper Saddle River, NJ, Prentice Hall, 1999, pp. iii-xix, 135-191.

Rijsinghani, A., RFC 1624, May 1994, [online], [retrieved Feb. 2, 2000]. Retrieved from the internet: URL: <http://www.faqs.org/rfcs/rfc1624.html>.

Mallory, T and Kullberg, A., RFC 1141, Jan. 1990 [online], [retrieved Feb. 2, 2000]. Retrieved from the Internet: URL: <http://www.faqs.org/rfcs/rfc1141.html>.

Egevang, K. and Francis P., RFC 1631, May 1994 [online], [retrieved on Feb. 2, 2000]. Retrieved from the Internet: URL: <http://www.faqs.org/rfcs/rfc1631.html>.

Goyal, P. et al., "Generalized Guaranteed Rate Scheduling Algorithms: A Framework," *IEEE/ACM Transactions*, vol. 5, Issue: 4, Aug. 1997; pp. 561-571.

Symbol Table, [online] copyright 1997, 1998, [Retrieved on Apr. 4, 2003] Retrieved from the internet < URL: http://216.239.33.100/search?q=cache:eASXk8qC_AC:www.caldera.com/developers/gabi/1998-04-29/ch4.s..., pp. 1-5.

U.S. Appl. No. 09/576,393, filed May 22, 2000, Keshav et al.

U.S. Appl. No. 09/747,664, filed Dec. 22, 2000, Huang et al.

U.S. Appl. No. 09/687,031, filed Oct. 12, 2000, Gylfason et al.

Goyal et al., "Start-time Fair Queuing: A Scheduling Algorithm for Integrated Services Packet Switching Networks," *IEEE/ACM Transactions on Networking*, vol. 5, No. 5, Oct. 1997, pp. 690-704.

(56)

References Cited

OTHER PUBLICATIONS

Mitra et al., "Hierarchical Virtual Partitioning—Algorithms for Virtual Private Networking", Bell Labs Technical Journal, Spring 1997, pp. 68-81.

Berkeley Software Distribution, "man page: setpgid", Feb. 1, 1994, 2 pp., [Retrieved on Oct. 13, 2005], Retrieved from the Internet <URL: <http://www.neosoft.com/neosoft/man/setpgid.2.html>>.

Berkeley Software Distribution, "man page: setsid", Feb. 1, 1994, 2 pp., [Retrieved on Oct. 13, 2005], Retrieved from the Internet <URL: <http://www.neosoft.com/neosoft/man/setsid.2.html>>.

Frost, J., "Unix Signals and Process Groups", Aug. 17, 1994, 2 pp., [Retrieved on Oct. 13, 2005], Retrieved from the Internet <URL: <http://www.cs.ucsb.edu/~almeroth/classes/W99.276/assignment1/signals.html>>.

Stevens, Richard W., "Advanced Programming in the Unix® Environment", 1993, pp. 237-246, 282-285, Addison Wesley Longman, Inc., USA.

Bhatti, N., Friedrich, R., "Web server support for tiered services", Network, IEEE, vol. 13, Issue 5, pp. 64-71, Sep.-Oct. 1999.

United States Patent and Trademark Office, Non-Final Office Action, U.S. Appl. No. 09/572,672, mailed Mar. 15, 2004, 32 pages.

United States Patent and Trademark Office, Notice of Allowance, U.S. Appl. No. 09/572,672, mailed Jan. 4, 2005, 13 pages.

United States Patent and Trademark Office, Supplemental Notice of Allowability, U.S. Appl. No. 09/572,672, mailed Feb. 9, 2005, 2 pages.

United States Patent and Trademark Office, Non-Final Office Action, U.S. Appl. No. 09/633,575, mailed Dec. 17, 2003, 33 pages.

United States Patent and Trademark Office, Final Office Action, U.S. Appl. No. 09/633,575, mailed Sep. 27, 2004, 38 pages.

United States Patent and Trademark Office, Notice of Allowance, U.S. Appl. No. 09/633,575, mailed Dec. 20, 2004, 7 pages.

United States Patent and Trademark Office, Non-Final Office Action, U.S. Appl. No. 09/611,877, mailed Feb. 4, 2004, 10 pages.

United States Patent and Trademark Office, Non-Final Office Action, U.S. Appl. No. 09/611,877, mailed Nov. 3, 2004, 8 pages.

United States Patent and Trademark Office, Non-Final Office Action, U.S. Appl. No. 09/611,877, mailed Mar. 15, 2005, 12 pages.

United States Patent and Trademark Office, Final Office Action, U.S. Appl. No. 09/611,877, mailed Aug. 11, 2005, 9 pages.

United States Patent and Trademark Office, Non-Final Office Action, U.S. Appl. No. 09/611,877, mailed Dec. 20, 2005, 8 pages.

United States Patent and Trademark Office, Final Office Action, U.S. Appl. No. 09/611,877, mailed Jun. 20, 2006, 9 pages.

United States Patent and Trademark Office, Notice of Allowance, U.S. Appl. No. 09/611,877, mailed Sep. 25, 2006, 5 pages.

United States Patent and Trademark Office, Non-Final Office Action, U.S. Appl. No. 09/452,286, mailed Apr. 28, 2003, 23 pages.

United States Patent and Trademark Office, Non-Final Office Action, U.S. Appl. No. 09/452,286, mailed Oct. 23, 2003, 33 pages.

United States Patent and Trademark Office, Final Office Action, U.S. Appl. No. 09/452,286, mailed Mar. 9, 2004, 34 pages.

United States Patent and Trademark Office, Non-Final Office Action, U.S. Appl. No. 09/452,286, mailed Oct. 14, 2004, 22 pages.

United States Patent and Trademark Office, Final Office Action, U.S. Appl. No. 09/452,286, mailed Mar. 15, 2005, 11 pages.

United States Patent and Trademark Office, Notice of Allowance, U.S. Appl. No. 09/452,286, mailed Jul. 8, 2005, 4 pages.

United States Patent and Trademark Office, Notice of Allowance, U.S. Appl. No. 11/956,246, mailed Apr. 6, 2010, 9 pages.

United States Patent and Trademark Office, Notice of Allowance, U.S. Appl. No. 11/956,246, mailed Aug. 23, 2010, 4 pages.

United States Patent and Trademark Office, Non-Final Office Action, U.S. Appl. No. 09/569,371, mailed Jul. 18, 2003, 14 pages.

United States Patent and Trademark Office, Final Office Action, U.S. Appl. No. 09/569,371, mailed Jan. 8, 2004, 11 pages.

United States Patent and Trademark Office, Non-Final Office Action, U.S. Appl. No. 09/569,371, mailed May 10, 2004, 11 pages.

United States Patent and Trademark Office, Non-Final Office Action, U.S. Appl. No. 09/569,371, mailed Jan. 25, 2005, 13 pages.

United States Patent and Trademark Office, Notice of Allowance, U.S. Appl. No. 09/569,371, mailed Jul. 11, 2005, 7 pages.

United States Patent and Trademark Office, Non-Final Office Action, U.S. Appl. No. 09/747,687, mailed Oct. 1, 2003, 11 pages.

United States Patent and Trademark Office, Non-Final Office Action, U.S. Appl. No. 09/747,687, mailed Mar. 25, 2004, 14 pages.

United States Patent and Trademark Office, Final Office Action, U.S. Appl. No. 09/747,687, mailed Dec. 1, 2004, 15 pages.

United States Patent and Trademark Office, Non-Final Office Action, U.S. Appl. No. 09/747,687, mailed May 4, 2005, 14 pages.

United States Patent and Trademark Office, Final Office Action, U.S. Appl. No. 09/747,687, mailed Nov. 1, 2005, 11 pages.

United States Patent and Trademark Office, Non-Final Office Action, U.S. Appl. No. 09/747,687, mailed Apr. 18, 2006, 10 pages.

United States Patent and Trademark Office Final Office Action, U.S. Appl. No. 09/747,687, mailed Oct. 18, 2006, 14 pages.

United States Patent and Trademark Office, Notice of Allowance, U.S. Appl. No. 09/747,687, mailed Feb. 12, 2007, 9 pages.

United States Patent and Trademark Office, Notice of Allowance, U.S. Appl. No. 09/499,098, mailed Sep. 24, 2002, 6 pages.

United States Patent and Trademark Office, Non-Final Office Action, U.S. Appl. No. 09/500,212, mailed Mar. 15, 2002, 16 pages.

United States Patent and Trademark Office, Non-Final Office Action, U.S. Appl. No. 09/500,212, mailed Sep. 9, 2002, 20 pages.

United States Patent and Trademark Office, Notice of Allowance, U.S. Appl. No. 09/500,212, mailed Dec. 31, 2002, 7 pages.

United States Patent and Trademark Office, Non-Final Office Action, U.S. Appl. No. 09/502,155, mailed Apr. 14, 2003, 11 pages.

United States Patent and Trademark Office, Final Office Action, U.S. Appl. No. 09/502,155, mailed Jul. 28, 2003, 10 pages.

United States Patent and Trademark Office, Notice of Allowance, U.S. Appl. No. 09/502,155, mailed Oct. 27, 2003, 5 pages.

United States Patent and Trademark Office, Notice of Allowance, U.S. Appl. No. 09/502,155, mailed Mar. 8, 2004, 7 pages.

United States Patent and Trademark Office, Notice of Allowance, U.S. Appl. No. 09/664,914, mailed Dec. 12, 2003, 5 pages.

United States Patent and Trademark Office, Supplemental Notice of Allowability, U.S. Appl. No. 09/664,914, mailed Dec. 29, 2003, 2 pages.

United States Patent and Trademark Office, Non-Final Office Action, U.S. Appl. No. 11/971,778, mailed Oct. 12, 2010, 17 pages.

United States Patent and Trademark Office, Notice of Allowance, U.S. Appl. No. 11/971,778, mailed Feb. 24, 2011, 5 pages.

United States Patent and Trademark Office, Non-Final Office Action, U.S. Appl. No. 12/467,137, mailed Feb. 26, 2010, 13 pages.

United States Patent and Trademark Office, Final Office Action, U.S. Appl. No. 12/467,137, mailed Oct. 15, 2010, 26 pages.

United States Patent and Trademark Office, Advisory Action, U.S. Appl. No. 12/467,137, mailed Jan. 18, 2011, 4 pages.

Pending U.S. Appl. No. 09/452,286, entitled "Providing Quality of Service Guarantees to Virtual Hosts," filed Nov. 30, 1999.

Pending U.S. Appl. No. 09/499,098, entitled "Selective Interception of System Calls," filed Feb. 4, 2000.

Pending U.S. Appl. No. 09/498,450, entitled "Dynamic Scheduling of Task Streams in a Multiple-Resource System to Ensure Task Stream Quality of Service," filed Feb. 4, 2000.

Pending U.S. Appl. No. 09/500,212, entitled "Disambiguating File Descriptors," filed Feb. 8, 2000.

Pending U.S. Appl. No. 09/502,155, entitled "Restricting Communication Between Network Devices on a Common Network," filed Feb. 11, 2000.

Pending U.S. Appl. No. 09/503,975, entitled "Restricting Communication of Selected Processes to a Set of Specific Network Addresses," filed Feb. 14, 2000.

Pending U.S. Appl. No. 09/526,980, entitled "Enabling a Service Provider to Provide Intranet Services," filed Mar. 15, 2000.

Pending U.S. Appl. No. 09/569,371, entitled "Dynamically Modifying the Resources of a Virtual Server," filed May 11, 2000.

Saltzer, J., H. and Schroeder, M. D., The Protection of Information in Computer Systems, [online], 1973, [retrieved on Apr. 2, 2002]. Retrieved from the Internet: URL: <http://www.cs.virginia.edu/~evans/cs551/saltzer>.

(56)

References Cited

OTHER PUBLICATIONS

McDougall, R., et al., *Resource Management*, Upper Saddle River, NJ, Prentice Hall, 1999, pp. iii-xix, 135-191.

Goyal, Pawan et al., *Generalized Guaranteed Rate Scheduling Algorithms: A Framework*, IEEE/ACM Transactions, vol. 5, Issue: 4, Aug. 1997; pp. 561-571.

* cited by examiner

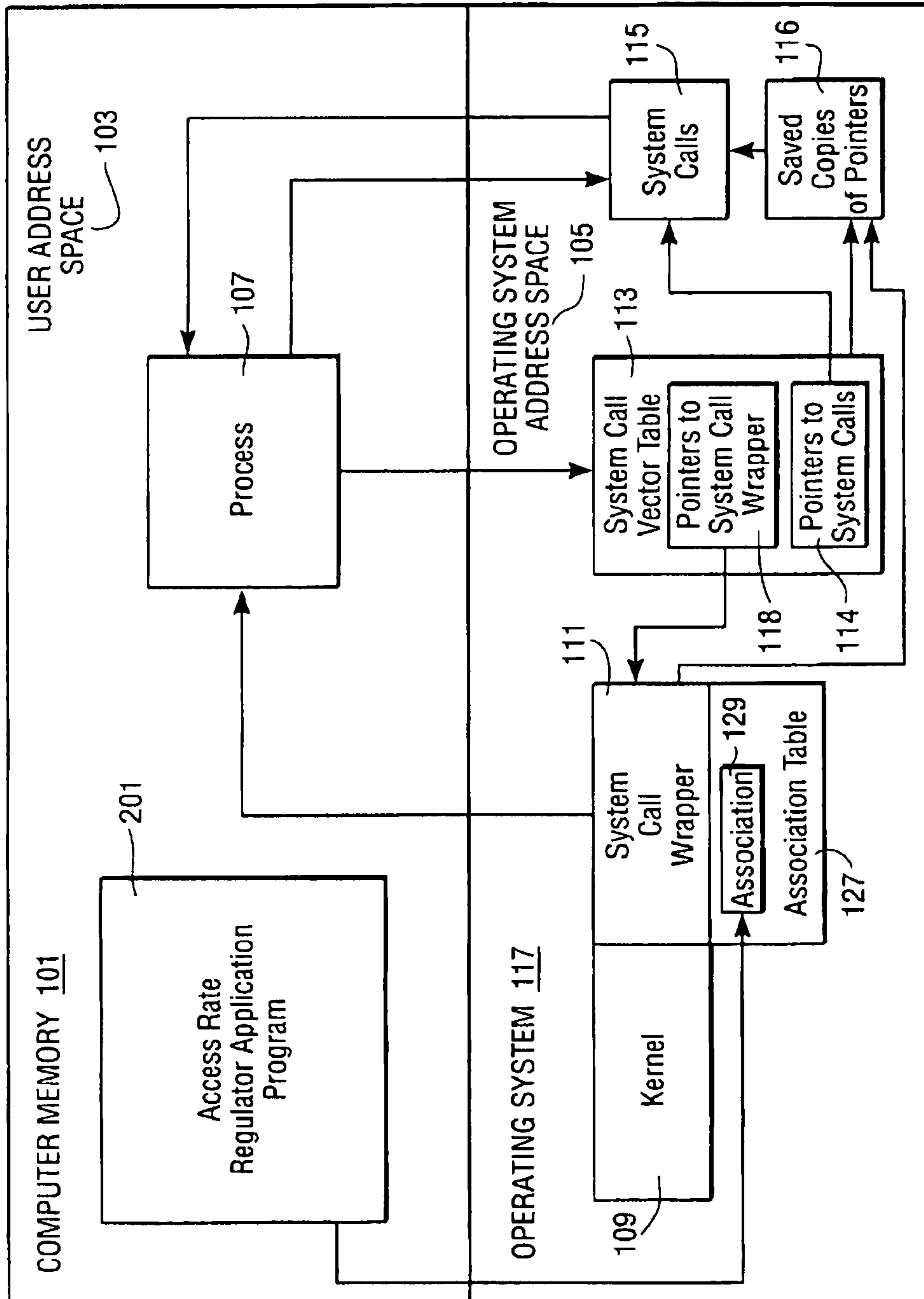

FIG. 2

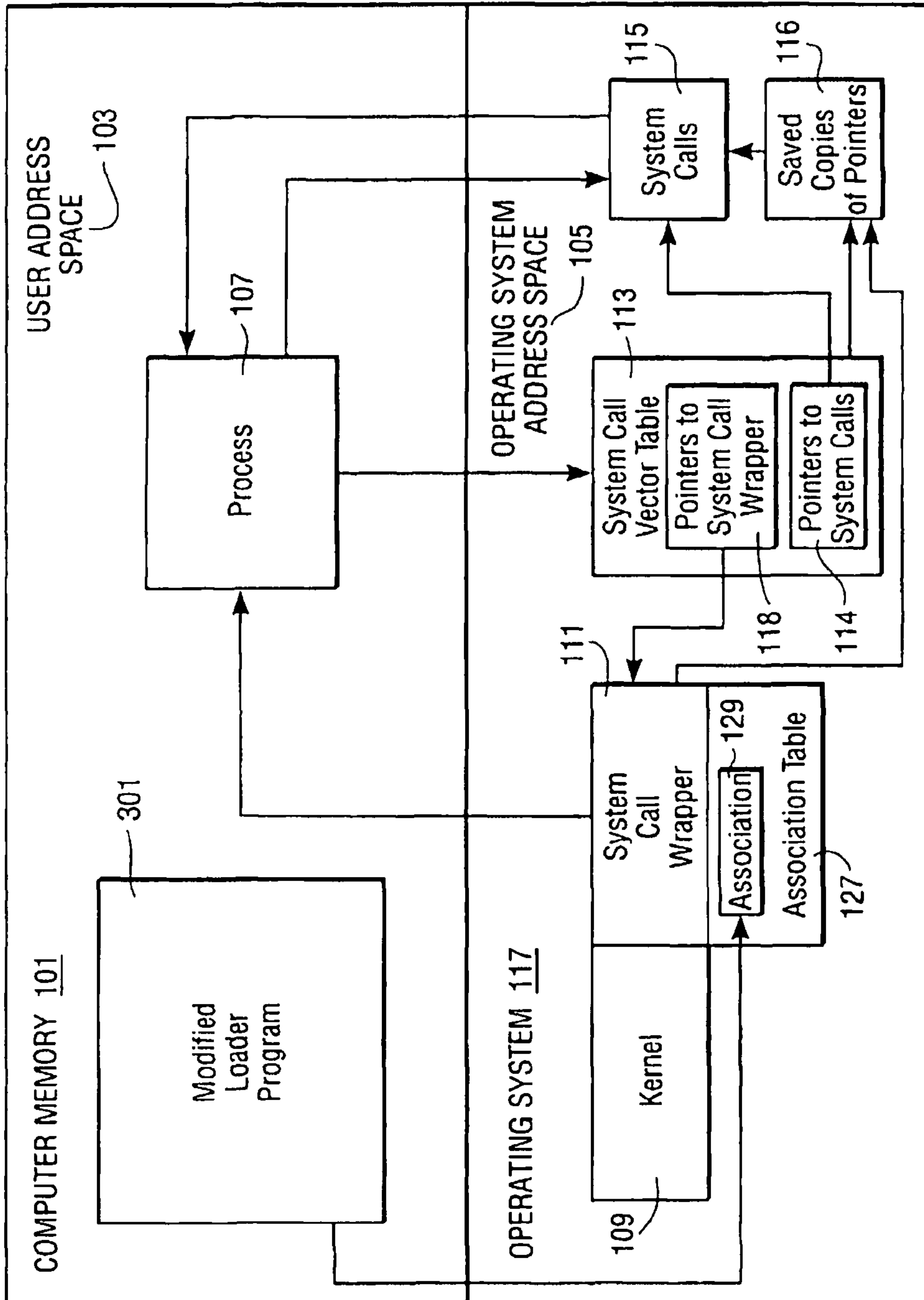

FIG. 3

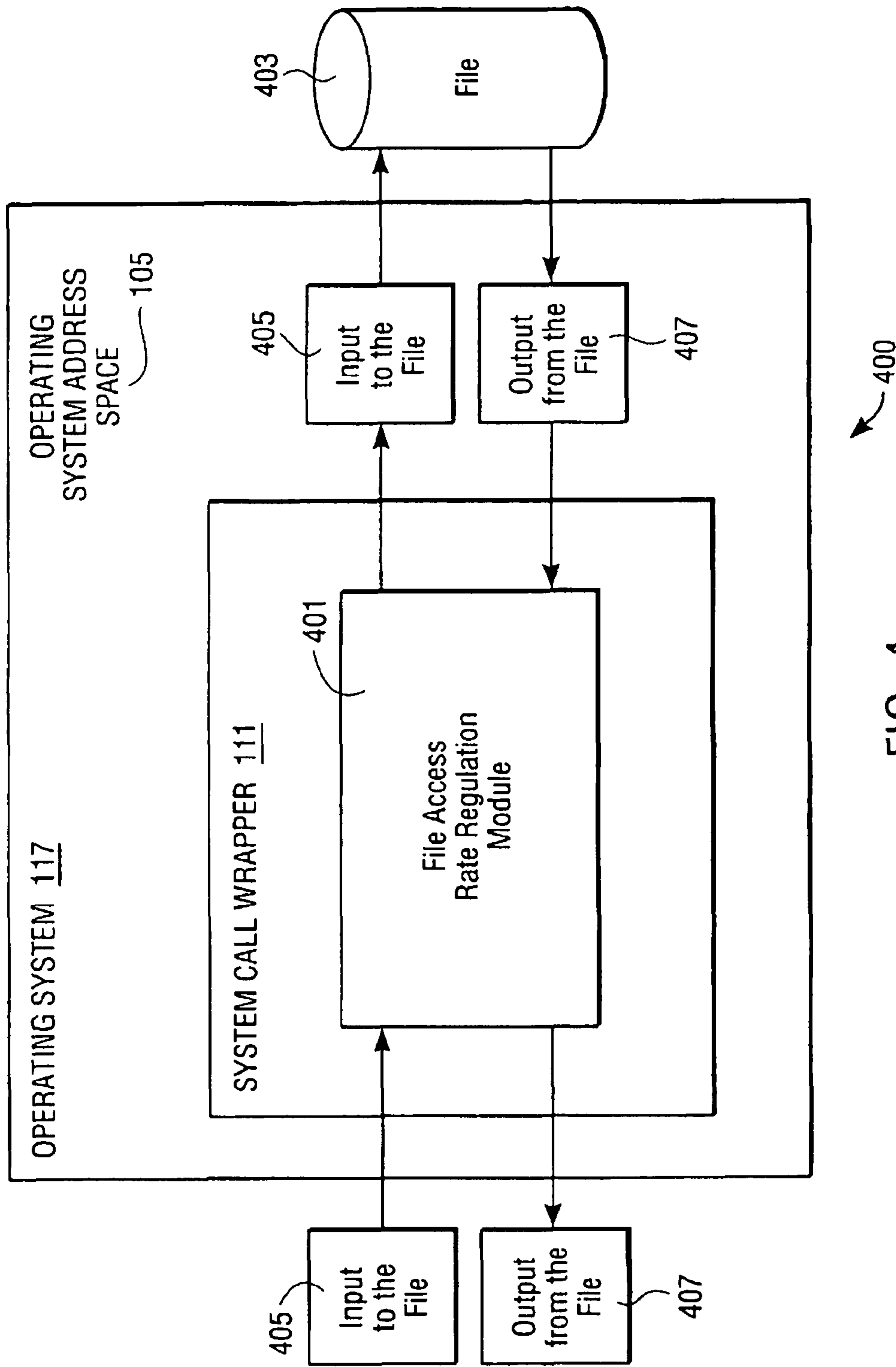

FIG. 4

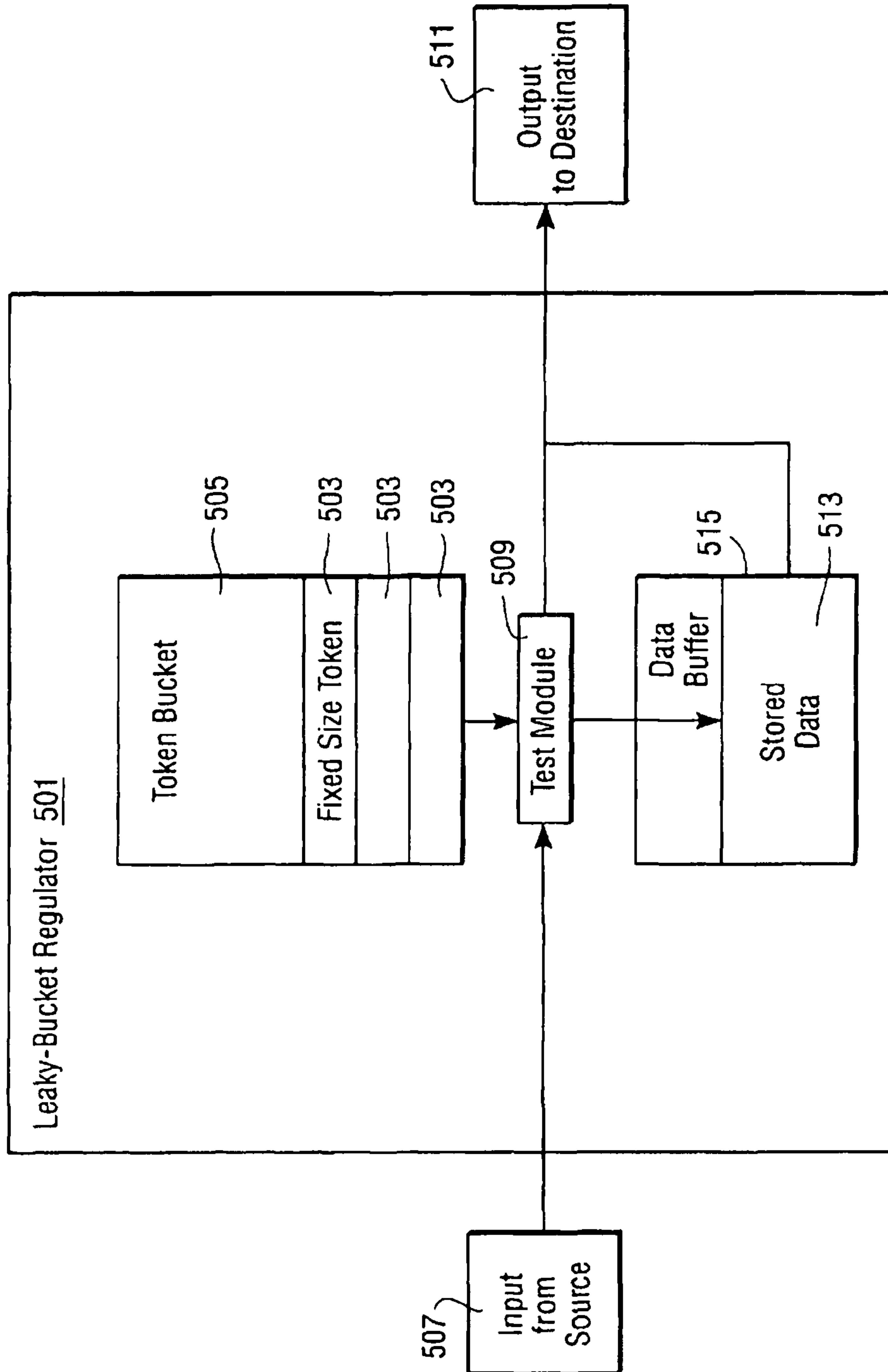

FIG. 5

**REGULATING FILE ACCESS RATES
ACCORDING TO FILE TYPE**

Matter enclosed in heavy brackets [] appears in the original patent but forms no part of this reissue specification; matter printed in italics indicates the additions made by reissue.

CROSS REFERENCE TO RELATED
APPLICATIONS

This application is a reissue application for U.S. Pat. No. 6,907,421, issued from U.S. patent application Ser. No. 09/572,672 filed on May 16, 2000, which incorporates by reference the entirety of the following patent applications: U.S. patent application Ser. No. 09/500,212, now U.S. Pat. No. 6,560,613 entitled "Disambiguating File Descriptors," filed on Feb. 8, 2000; U.S. patent application Ser. No. 09/499,098, now U.S. Pat. No. 6,529,985 entitled "Selective Interception of System Calls," filed on Feb. 4, 2000; and U.S. patent application Ser. No. 09/452,286, now pending entitled "Providing Quality of Service Guarantees to Virtual Hosts," filed on Nov. 30, 1999. The incorporated applications have the same assignee as the present application.

BACKGROUND

1. Field of Invention

The present invention relates generally to regulating access rates in a computer system, and specifically to regulating file access rates of software processes according to file type.

2. Background of Invention

Multitasking operating systems such as UNIX® and Microsoft WINDOWS NT® are widely utilized in commercial computing systems. Among their many commercial uses, these operating systems are commonly deployed on Internet and other network server computers. With the popularity and success of the Internet, server computer operating systems are currently of great commercial importance.

One function of a multitasking operating system is to allocate system resources to the multiple software processes that simultaneously execute under the control of the operating system. Control over the allocation of system resources by an operating system is commercially useful for a number of reasons. Multitasking operating systems are commonly used on Internet web servers by Internet Service Providers (ISP's). Where an ISP provides host services to multiple customers on a single physical computer, it is desirable to allot to each virtual host a specific amount of computer resources appropriate to the needs of the customer, and preferably based upon the amount paid for the services.

For example, suppose two customers purchase host services from an ISP. The first customer is a large corporation providing financial services to thousands of clients internationally. The financial services host requires fast file access, as well as prompt response time to all client requests. Of course, the first customer is willing to compensate the ISP appropriately for providing such a level of host services. The second customer is a sole proprietorship that sells floral arrangements locally. The second customer has a very limited budget, but only requires minimal computer resources. Clearly, it is desirable for the ISP to allocate different percentages of the system resources to the two separate virtual hosts provided by the ISP for the two separate customers.

In the example above, the ISP may wish to provide the financial services host with the ability to access files at the rate

of 1,000 bytes per second, but to allow the florist to access files at the rate of only 150 bytes per second. These different access rates would be based upon the different needs of the two customers, and the corresponding different compensation schemes of each. As multitasking operating systems operate today, it would be impossible for the ISP to regulate the file access rates of the different customers. Each process associated with either virtual host simply accesses the file system at the same unregulated rate, and thus it is impossible for the ISP to guarantee or restrict access rates based upon customer need and corresponding financial arrangement. What is needed is a method that facilitates the regulation of the rate at which individual processes access the file system of a multitasking operating system.

Many commercially popular operating systems such as UNIX® and Microsoft WINDOWS NT® treat communication channels as files. In such an operating system, when a process instructs the operating system to create a communication channel, the operating system returns a file descriptor. The communication channel is subsequently accessed via the file descriptor, in a similar manner as a file stored on media.

Communication channels and files stored on media are inherently different, despite the fact that both are accessed via file descriptors. It is often desirable to for an ISP to allow a single process to access files stored on media at one rate, and to access communication channels at another. For example, a customer of the ISP may need to receive and respond to client requests very quickly, but need only an average access time for files stored on the system storage device(s). Such a customer would require (and be willing to pay for) a fast communication channel access rate, but only need (and be willing to pay for) a slower access rate to files stored on media.

Multitasking operating systems today are not capable of regulating the file access rates of different processes generally, much less facilitating different access rates for specific processes based on file type. Currently, each process accesses both files stored on media and communication channels at unregulated rates, not controlled by the operating system. Thus, it is impossible for the ISP to provide customers with different access rates for files stored on media and for communication channels, based upon customer need and corresponding financial arrangement. What is further needed is a method that not only facilitates the regulation of the rate at which individual processes access the file system of a multitasking operating system, but which also allows processes to be regulated to different access rates for different file types.

It is further desirable to not only be able to set separate access rates for communication channels and files stored on media, but to be able set separate access rates for file types generally. Under some operating systems, entities other than communication channels and files stored on media are treated as files, and hence need separate access rates. For example, under the UNIX® operating system, hardware devices are treated as files. For the same reasons that it is desirable to set separate access rates for communication channels and files stored on media, it is further desirable to be able to set a separate access rate for any type of file. Accordingly, what is needed is a method to set separate access rates for individual processes according to file type.

SUMMARY OF INVENTION

The present invention allows regulation of the file access rates of processes according to file type. An association data structure stores associations between processes to be regulated and specific access rates for various file types. In order to regulate processes to their associated access rates, system

calls that access files are intercepted. When a process to be regulated makes a system call that accesses a file, the system call is intercepted, and a system call wrapper executes instead. The system call wrapper determines the type of file that is being accessed by the process. The system call wrapper examines the association table in order to determine if the calling process is associated with an access rate for that file type. If not, then the process is not to be regulated for that file type, in which case the system call wrapper simply allows the file access to proceed. Otherwise, the system call wrapper regulates the rate of the access to the file according to the appropriate rate.

The features and advantages described in this summary and the following detailed description are not all-inclusive, and particularly, many additional features and advantages will be apparent to one of ordinary skill in the art in view of the drawings, specification, and claims hereof. Moreover, it should be noted that the language used in the specification has been principally selected for readability and instructional purposes, and may not have been selected to delineate or circumscribe the inventive subject matter, resort to the claims being necessary to determine such inventive subject matter.

BRIEF DESCRIPTION OF THE DRAWINGS

FIG. 1 is a block diagram providing a high level overview of a system for regulating file access rates of processes based upon file type, according to one embodiment of the present invention.

FIG. 2 is a block diagram illustrating a system for managing an association table by an access rate regulator program, according to one embodiment of the present invention.

FIG. 3 is a block diagram illustrating a system for managing an association table by a modified loader program, according to another embodiment of the present invention.

FIG. 4 is a block diagram illustrating a system for regulating file access rate, according to one embodiment of the present invention.

FIG. 5 is a block diagram illustrating a leaky-bucket regulator according to one embodiment of the present invention.

The figures depict embodiments of the present invention for purposes of illustration only. One skilled in the art will readily recognize from the following discussion that alternative embodiments of the structures and methods illustrated herein may be employed without departing from the principles of the invention described herein.

DETAILED DESCRIPTION OF THE PREFERRED EMBODIMENTS

I. System Overview

FIG. 1 illustrates a high level overview of a system 100 for regulating file access rates of processes 107 based upon file type according to one embodiment of the present invention. A computer memory 101 includes user address space 103 and operating system address space 105. A process 107 executes in user address space 103. Although FIG. 1 illustrates only a single process 107 executing in user address space 103, it is to be understood that within a given computer memory 101, multiple processes 107 can execute simultaneously.

Preferably, a data structure for storing associations 129 between processes 107 and access rates for file types is inserted into the operating system 117. In one embodiment, the data structure is an association table 127, but in other embodiments other data structures are utilized, for example a linked list. In one embodiment, the association table 127 (or

other data structure) is dynamically loaded into the operating system kernel 109, while the kernel 109 is active. In another embodiment, the association table 127 is stored in user address space 103. The maintenance and use of the association table 127 is discussed in detail below.

In order to regulate file access rates, system calls 115 that access files are intercepted. A system call wrapper 111 is utilized in order to intercept system calls 115. In one embodiment, the system call wrapper 111 is dynamically loaded into the operating system kernel 109, while the kernel 109 is active. In another embodiment, the system call wrapper is loaded in user address space 103. The system call wrapper 111 is preferably in the form of object code, the functional features of which are described in detail below.

Pointers 114 to system calls 115 are located in an operating system call vector table 113. It is to be understood that the term "system call vector table" as used herein denotes an area in operating system address space 105 in which there are stored the addresses of system calls. In the UNIX® operating system, this part of the operating system is called the "system call vector table," and that term is used in this specification. Other operating systems employ different terminology to denote the same system component. A system call vector table by any other name is still within the scope of the present invention.

A copy 116 is made of a pointer 114 to each system call 115 to be intercepted. These copies 116 of pointers 114 are preferably stored in operating system address space 105, but in an alternative embodiment are stored in user address space 103.

Once the copies 116 have been made and saved, the pointers 114 in the system call vector table 113 to the system calls 115 to be intercepted are replaced with pointers 118 to the system call wrapper 111, such that when a system call 115 to be intercepted is made, the system call wrapper 111 executes instead. In one embodiment, this copying, storing, and replacing of pointers is performed by the system call wrapper 111. In other embodiments, copying, storing, and replacing of pointers is performed by a pointer management module executing in either operating system address space 105 or user address space 103 as desired. The pointer management module can either be a stand alone program, or a component of a larger application program as desired.

Executing alternative code when a system call 115 is made comprises intercepting the system call 115. The steps of inserting a system call wrapper 111 into the operating system 117, making a copy 116 of an operating system pointer 114 to a system call 115, and replacing the operating system pointer 114 with a pointer 118 to the system call wrapper 111 facilitate interception of a system call 115. When a system call 115 to be intercepted is made, the operating system 117 uses the pointer 118 in the system call vector table 113 to the system call wrapper 111 to execute the system call wrapper 111.

It is to be understood that only system calls 115 that access files need be intercepted, and thus only pointers 114 to system calls 115 to be intercepted are replaced with pointers 118 to the system call wrapper 111. Pointers 114 to system calls 115 which are not to be intercepted are not replaced. Thus, when a non-intercepted system call 115 is made, the system call 115 executes, not the system call wrapper 111.

In one embodiment, a single system call wrapper 111 is loaded into operating system address space 105. Thus, whenever any process 107 makes a system call 115 to be intercepted, the system call wrapper 111 executes. In another embodiment, techniques described in the "Selective Interception of System Calls" application are used to associate a specific system call wrapper 111 with each process to be regulated.

Processes **107** execute in user address space **103** under control of the operating system **117**, and make system calls **115**. When a process makes a system call **115** that accesses a file, the system call wrapper **111** determines the type of the file being accessed. The system call wrapper **111** also examines the association table **127** to determine whether the process **107** that made the system call **115** is associated with an access rate for that file type. If so, the system call wrapper **111** regulates the file access rate appropriately. Otherwise, the access is allowed to proceed normally. Note that even in the embodiment in which processes **107** to be regulated are associated with individual system call wrappers **111**, the system call wrapper still determines if the process **107** is associated with a rate for the file type being accessed, because an individual process **107** may be regulated for some file types and not for others.

II. Storing Associations by a Regulator Program

FIG. 2 illustrates one embodiment of a system **200** for regulating file access rates of processes **107** based upon file type. In the embodiment illustrated by FIG. 2, the association table **127** is managed by an access rate regulator program **201**.

The access rate regulator program **201** modifies the operating system **117** of the computer to include the association table **127**. Preferably, the regulator program **201** loads the association table **127** into the kernel **109** of the operating system **117** while the kernel is active.

For each process **107** to be regulated, the regulator program **201** stores, in the association table **127**, an association **129** between the process **107** and an access rate for at least one file type. For example, suppose a process **107** associated with a financial services host is to be regulated to 1,000 bytes per second for files stored on media, and to 1,400 bytes per second for communication channels. The regulator program **201** would store two associations for the process **107**, the first indicating the access rate for files stored on media (1,000 bytes per second), and the second the access rate for communication channels (1,400 bytes per second). Of course, the regulator program **201** can add, modify, and delete associations **129** from the association table **127**, as desired.

III. Storing Associations by a Loader Program

FIG. 3 illustrates another embodiment of a system **300** for regulating file access rates of processes **107** based upon file type. In the embodiment illustrated by FIG. 3, processes **107** to be regulated are loaded by the modified loader program **301**, which also stores the associations **129**.

A loader program is an operating system utility that is used to execute computer programs that are stored on static media. Typically, a loader program loads an executable image from static media into user address space **103** of computer memory **101**, and then initiates execution of the loaded image by transferring execution to the first instruction thereof.

Like a standard loader program, the modified loader **301** loads executable images from static media into user address space **103**. Additionally, the modified loader program **301** stores, in the association table **127**, at least one association **129** between the process **107** and a file access rate. Thus, whenever a process **107** to be regulated is loaded, the association table **127** is updated as needed.

In other embodiments, in addition to storing associations, the modified loader program **301** uses methodology described in detail in the "Selective Interception of System Calls" application in order to associate an individual system call wrapper **111** with the loaded process **107**. In different

embodiments, the system call wrapper **111** associated with the process is loaded into process address space of the process, user address space **103**, or operating system address space **105** as described in the "Selective Interception of System Calls" application. In each of these embodiments, whenever the process **107** makes a system call **115** to be intercepted (i.e., a system call **115** that accesses a file) the system call wrapper **111** associated with the process **107** executes, and proceeds to manage the regulation of the file access rate. Regulation of file access rate by system call wrappers **111** generally is discussed in detail below.

IV. Determining the File Type

When a system call wrapper **111** executes, the system call wrapper determines the type of the file being accessed. Once the file type has been determined, the system call wrapper **111** examines the association table **127** to determine whether the process **107** that made the system call **115** is associated with an access rate for that file type. If so, the system call wrapper **111** regulates the file access rate appropriately. Otherwise, access of files of that type by the process **107** is not to be regulated, so the access is allowed to proceed normally. In one embodiment, the determination is made using methodology described in the "Disambiguating File Descriptors" application. Other techniques such as file extension or file name can also be used as desired.

V. Regulating the Access Rate

FIG. 4 illustrates one embodiment of a system **400** for regulating file access rate. After determining the file type being accessed, the system call wrapper **111** executes a file access rate regulation module **401** in order to regulate the access rate of the file **403** by the process **107**. In one embodiment, the file access rate regulation module **401** executes in operating system address space **105**, as illustrated in FIG. 4. In another embodiment, the file access rate regulation module **401** executes in user address space **103**. The file access rate regulation module **401** can either be a section of the system call wrapper (as illustrated), a stand alone program, or a component of a larger application program as desired. In any case, the file access rate regulation module **401** applies a known rate regulation technique to the access of the file **403** by the process **107**. More specifically, data being written to the file **403** by the process (input to the file **405**) is routed through the file access rate regulation module **401**. The file access rate regulation module **401** controls the rate at which the input **405** is sent to the file **403** by the process. Likewise, data read by the process **107** from the file (output from the file **407**) is also routed through the file access rate regulation module **401**, which controls the rate at which the output **407** is sent to the process **107**.

Many techniques for regulating access rate are known. In one embodiment, the file access rate regulation module **401** uses a leaky-bucket regulator to regulate the access rate. A leaky-bucket regulator is one specific example of a technique for regulating access rates. A leaky-bucket regulator is described in An Engineering Approach to Computer Networking, Srinivasan Keshav, 1997, Addison Wesley, Chapter 7, at pp 403-405, which is incorporated herein by reference.

FIG. 5 illustrates a leaky-bucket regulator **501**. As illustrated in FIG. 5, the leaky-bucket regulator **501** stores fixed sized tokens **503** in a data structure known as a token (or leaky) bucket **505**. Each token **503** constitutes permission for the regulator **501** to send a certain number of bits to a destination. The regulator **501** adds tokens **503** to the bucket **505** at

a fixed rate, R. The bucket 505 overflows if the number of tokens 503 crosses some threshold, called its depth, D.

Data arrives at the regulator 501 as input 507 from a source. A test module 509 examines the bucket 505, to determine the sum of the sizes of the tokens 503 therein. The regulator 501 only sends the data as output to a destination 511 if the sum equals or exceeds the size of the data. When data is sent as output 511, the regulator 501 removes tokens 503 corresponding to the output 511 size from the token bucket 505.

If the sum is less than the size of the input 507, the input 507 is held as stored data 513 in a data buffer 515. Once the bucket 505 contains sufficient tokens 503, the stored data 513 is sent as output 511.

A leaky-bucket regulator 501 limits the size of a burst of output 511 to a little more D. The size can be slightly greater than D because tokens 503 may be added to the bucket 505 while output 511 equal in size to D is being sent. Over the long term, the rate at which output 511 is sent by the regulator 501 is limited by the rate R at which tokens 503 are added to the bucket 505. Thus, the leaky-bucket regulator 501 can be used to regulate a process 107 to an access rate for a file type by setting R to that access rate.

For example, suppose the system call wrapper 111 determines that the file access write for a process 107 is 1,000 bytes per second. The system call wrapper passes the rate to the leaky-bucket regulator 501, which proceeds to set R to the rate. Thus, the regulator 501 adds 1,000 byte tokens 503 to a bucket 505 at a rate of once per second. The system call wrapper 111 then routes the communication between the process 107 and the file through the regulator 501, which regulates the access rate to 1,000 bytes per second.

Note that if the process 107 is writing data to a file 403, the input to the file 403 becomes the input 507 to the leaky bucket regulator 501, and the output 511 from the leaky bucket regulator 501 is sent to the file 403. On the other hand, if the process 107 is reading data from a file 403, the output from the file 403 becomes the input 507 to the leaky bucket regulator 501, and the output 511 from the leaky bucket regulator 501 is sent to the process 107.

In other embodiments, other access rate techniques are employed by the file access rate regulation module 401, for example moving average, jumping average, or peak rate.

As will be understood by those familiar with the art, the invention may be embodied in other specific forms without departing from the spirit or essential characteristics thereof. Likewise, the particular capitalization or naming of the modules, protocols, features, attributes or any other aspect is not mandatory or significant, and the mechanisms that implement the invention or its features may have different names or formats. Accordingly, the disclosure of the present invention is intended to be illustrative, but not limiting, of the scope of the invention, which is set forth in the following claims.

What is claimed is:

1. A computer-implemented method for regulating file access rates of processes according to file type, the computer-implemented method comprising:

intercepting a system call that attempts to access a file;
determining whether a process that made the intercepted system call is associated with an access rate corresponding to a type of the file being accessed;
in response to the attempt to access the file by the process, determining the associated access rate for the type of the file being accessed; and
regulating the process to access of the file at the determined rate.

2. The method of claim 1 further comprising:
storing an association between a selected process and the access rate for at least one file type.

3. The method of claim 2 wherein:
storing the association is performed by a process executing in user address space.

4. The method of claim 1 further comprising:
selecting a process to associate with an access rate for at least one file type;

loading the selected process into process address space by a modified loader program; and
storing, by the modified loader program, an association between the selected process and the access rate for at least one file type.

5. The method of claim 1 further comprising:
associating at least two different access rates with a single process, each access rate corresponding to a different file type.

6. The method of claim 1 further comprising:
associating at least two different access rates with at least two different processes.

7. The method of claim 1 wherein:
in response to the determination that the process is associated with the access rate, regulating the process to access of the file at the associated rate.

8. The method of claim 1, further comprising:
determining the type of the file being accessed.

9. The method of claim 1, further comprising:
associating at least one process with the access rate for at least one file access type.

10. A computer-readable program product for regulating file rates of processes according to file type, the computer-readable program product comprising:

program code for intercepting a system call that attempts to access a file;

program code for determining whether a process that made the intercepted system call is associated with an access rate corresponding to a type of the file being accessed;

program code for, in response to the attempt to access the file by the process, determining the associated access rate for the type of the file being accessed;

program code for regulating the process to access of the file at the determined rate; and

a computer readable medium on which the program codes are stored.

11. The computer-readable program product of claim 10 further comprising:

program code for storing an association between a selected process and an access rate for at least one file type.

12. The *non-transitory* computer-readable [program product] medium of claim 10 further comprising:

program code for selecting a process to associate with the access rate for at least one file type;

program code for loading the selected process into process address space; and
program code for storing an association between the selected process and the access rate for at least one file type.

13. The *non-transitory* computer-readable [program product] medium of claim 10 further comprising:

program code for associating at least two different access rates with a single process, each access rate corresponding to a different file type.

14. The *non-transitory* computer-readable [program product] medium of claim 10 further comprising:

program code for associating at least two different access rates with at least two different processes.

9

15. The *non-transitory* computer-readable [program product] *medium* of claim 10 further comprising:

program code for, in response to the determination that the process is associated with the access rate, regulating the process to access of the file at the associated rate.

16. The *non-transitory* computer-readable [program product] *medium* of claim 10 further comprising:

program code for determining the type of the file being accessed.

17. The computer-readable program product of claim 10 further comprising:

program code for associating at least one process with the access rate for at least one file type.

18. A computer implemented system for regulating file access rates of processes according to file type, the system comprising:

an interception module, for intercepting system calls that access files, the interception module being coupled to a determination module;

at least one system call wrapper, for determining whether a process that made an intercepted system call is associated with an access rate corresponding to a type of the file being accessed, the system call wrapper being coupled to the interception module;

the determination module for, in response to an attempt to access a file by the process, determining the associated access rate for the type of the file being accessed; and

10

coupled to the determination module, a file access rate regulation module, for regulating the process to access of the file at the determined rate.

19. The computer system of claim 18 further comprising: a selection module for selecting the process to associate with the access rate for at least one file type, the selection module being coupled to the determination module; and a modified loader program for loading the selected process into process address space, and for storing the association between the selected process and the access rate for at least one file type, the modified loader program being coupled to the selection module.

20. The computer system of claim 18 further comprising: a storage module, for storing the association between a selected process and the access rate for at least one file type, the storage module being coupled to the determination module.

21. A computer-implemented method for regulating file access rates of processes according to file type, the method comprising:

associating processes with rates for accessing files of specific types;

detecting attempts by processes to access files by intercepting system calls that access files;

determining associated access rates for the types of files being accessed; and

regulating processes to access [of] the files at the associated rates.

* * * * *