

US00RE44693E

(19) **United States**
 (12) **Reissued Patent**
Köster et al.

(10) **Patent Number:** **US RE44,693 E**
 (45) **Date of Reissued Patent:** **Jan. 7, 2014**

(54) **BEADS BOUND TO A SOLID SUPPORT AND TO NUCLEIC ACIDS**

(75) Inventors: **Hubert Köster**, Berlin (DE); **David M. Lough**, Cambridge, MA (US)

(73) Assignee: **Sequenom, Inc.**, San Diego, CA (US)

(21) Appl. No.: **12/507,124**

(22) Filed: **Jul. 22, 2009**

Related U.S. Patent Documents

Reissue of:

(64) Patent No.: **6,133,436**
 Issued: **Oct. 17, 2000**
 Appl. No.: **08/933,792**
 Filed: **Sep. 19, 1997**

U.S. Applications:

(63) Continuation of application No. 10/277,021, filed on Oct. 17, 2002, now Pat. No. Re. 41,005, which is a continuation-in-part of application No. 08/746,036, filed on Nov. 6, 1996, now Pat. No. 5,900,481.

(51) **Int. Cl.**
C12Q 1/68 (2006.01)
C07H 21/04 (2006.01)
C07H 21/00 (2006.01)

(52) **U.S. Cl.**
 USPC **435/6.11**; 435/6.1; 435/6.12; 435/288.4;
 436/501; 536/23.1; 536/24.3; 536/25.4; 502/233;
 525/332.2

(58) **Field of Classification Search**
 CPC B01J 2219/00646; B01J 2219/00648
 See application file for complete search history.

(56) **References Cited**

U.S. PATENT DOCUMENTS

4,139,346 A	2/1979	Rabbani
4,582,789 A	4/1986	Sheldon, III et al.
4,683,194 A	7/1987	Saiki et al.
4,683,195 A	7/1987	Mullis et al.
4,725,677 A	2/1988	Koster et al.
4,729,947 A	3/1988	Middendorf et al.
4,749,742 A	6/1988	Elmore
4,757,141 A	7/1988	Fung et al.
4,794,150 A	12/1988	Steel
4,797,355 A	1/1989	Stabinsky
4,806,546 A	2/1989	Carrico et al.
4,855,225 A	8/1989	Fung et al.
4,882,127 A	11/1989	Rosenthal et al.
4,948,882 A	8/1990	Ruth
4,983,521 A	1/1991	Lingappa et al.
4,994,373 A	2/1991	Stavrianopoulos et al.
5,003,059 A	3/1991	Brennan
5,037,882 A	8/1991	Steel
5,045,694 A	9/1991	Beavis et al.
5,064,754 A	11/1991	Mills

5,077,210 A	12/1991	Eigler et al.
5,082,935 A	1/1992	Cruickshank
5,118,605 A	6/1992	Urdea
5,118,937 A	6/1992	Hillenkamp et al.
5,135,870 A	8/1992	Williams et al.
5,149,625 A	9/1992	Church et al.
5,198,531 A	3/1993	Webber et al.
5,210,412 A	5/1993	Levis et al.
5,221,518 A	6/1993	Mills
5,234,824 A	8/1993	Mullis
5,237,016 A	8/1993	Ghosh et al.
5,242,974 A	9/1993	Holmes
5,283,342 A	2/1994	Gustavson et al.
5,288,644 A	2/1994	Beavis et al.
5,380,489 A	1/1995	Sutton et al.
5,380,833 A	1/1995	Urdea
5,410,068 A	4/1995	Coull et al.
5,430,136 A	7/1995	Urdea et al.
5,436,327 A	7/1995	Southern et al.
5,474,895 A	12/1995	Ishii et al.
5,478,893 A	12/1995	Ghosh et al.
5,484,701 A	1/1996	Cocuzza et al.
5,492,821 A	2/1996	Callstrom et al.
5,503,980 A	4/1996	Cantor
5,506,348 A	4/1996	Pieles
5,512,439 A	4/1996	Hornes et al.
5,514,548 A	5/1996	Krebber et al.
5,516,635 A	5/1996	Ekins et al.
5,527,675 A	6/1996	Coull et al.

(Continued)

FOREIGN PATENT DOCUMENTS

DE	3930312	4/1990
DE	4011991	10/1990

(Continued)

OTHER PUBLICATIONS

Dolitzky, Y. et al "Synthesis, characterization and use of immobilized polyacrolein microspheres in diagnostics . . ." Anal. Biochem. (1994) vol. 220, pp. 257-267.*

(Continued)

Primary Examiner — Leigh Maier

(74) *Attorney, Agent, or Firm* — Grant Anderson LLP

(57) **ABSTRACT**

Novel compositions comprised of at least one bead conjugated to a solid support and further conjugated to at least one nucleic acid and preferred methods for making the novel compositions are described. As compared to "flat" surfaces, beads linked to a solid support provide an increased surface area for immobilization of nucleic acids. Furthermore, by selecting a bead with the desired functionality, a practitioner can select a functionalization chemistry for immobilizing nucleic acids, which is different from the chemistry of the solid support.

11 Claims, 14 Drawing Sheets

(56)

References Cited

U.S. PATENT DOCUMENTS

5,541,313 A 7/1996 Ruth
 5,545,539 A 8/1996 Miller
 5,547,835 A 8/1996 Koster et al.
 5,552,535 A 9/1996 McLean et al.
 5,571,902 A 11/1996 Ravikumar et al.
 5,580,733 A 12/1996 Levis et al.
 5,583,042 A 12/1996 Roth
 5,601,982 A 2/1997 Sargent et al.
 5,604,097 A 2/1997 Brenner
 5,605,798 A 2/1997 Koster
 5,612,474 A 3/1997 Patel
 5,616,698 A 4/1997 Krepinsky et al.
 5,616,700 A 4/1997 Reddy et al.
 5,622,824 A 4/1997 Koster
 5,624,711 A 4/1997 Sundberg et al.
 5,631,134 A 5/1997 Cantor
 5,635,598 A 6/1997 Lebl et al.
 5,639,633 A 6/1997 Callstrom et al.
 5,641,862 A 6/1997 Rutter et al.
 5,643,722 A 7/1997 Rothschild et al.
 5,643,798 A 7/1997 Beavis et al.
 5,648,462 A 7/1997 Funakoshi et al.
 5,648,480 A 7/1997 Letsinger et al.
 5,650,277 A 7/1997 Navot et al.
 5,652,358 A 7/1997 Ptleiderer et al.
 5,663,242 A 9/1997 Ghosh et al.
 5,668,266 A 9/1997 Ruth
 5,670,322 A 9/1997 Eggers et al.
 5,677,195 A 10/1997 Winkler et al.
 5,679,773 A 10/1997 Holmes
 5,691,141 A 11/1997 Koster
 5,700,642 A * 12/1997 Monforte et al. 435/6
 5,726,243 A 3/1998 Fields
 5,736,625 A 4/1998 Callstrom et al.
 5,736,626 A 4/1998 Mullah et al.
 5,742,049 A 4/1998 Holle et al.
 5,795,714 A 8/1998 Cantor et al.
 5,830,655 A 11/1998 Monforte et al.
 5,864,137 A 1/1999 Becker et al.
 5,869,242 A 2/1999 Kamb
 5,900,481 A 5/1999 Lough et al.
 6,133,436 A 10/2000 Koster
 6,376,044 B1 4/2002 Jarrell et al.
 RE41,005 E 11/2009 Koster

WO WO 89/12624 11/1989
 WO WO 90/01564 2/1990
 WO WO 90/03382 4/1990
 WO WO 90/07582 7/1990
 WO WO 90/15883 12/1990
 WO WO 91/06678 5/1991
 WO WO 91/08307 * 6/1991
 WO WO 91/13075 9/1991
 WO WO 91/17427 11/1991
 WO WO 92/03575 3/1992
 WO WO 92/04465 3/1992
 WO WO 92/07096 4/1992
 WO WO 92/07879 5/1992
 WO WO 92/10092 6/1992
 WO WO 92/10743 6/1992
 WO WO 92/13629 8/1992
 WO WO 92/15712 9/1992
 WO WO 93/06925 4/1993
 WO WO 93/08472 4/1993
 WO WO 93/09668 5/1993
 WO WO 93/20236 10/1993
 WO WO 94/11421 5/1994
 WO WO 94/11529 5/1994
 WO WO 94/11530 5/1994
 WO WO 94/11735 5/1994
 WO WO 94/16101 7/1994
 WO WO 94/19693 9/1994
 WO WO 94/21822 9/1994
 WO WO 95/04524 2/1995
 WO WO 95/30773 11/1995
 WO WO 95/31429 11/1995
 WO WO 96/01836 1/1996
 WO WO 96/37630 5/1996
 WO WO 96/19587 6/1996
 WO WO 96/29431 9/1996
 WO WO 96/32504 10/1996
 WO WO 96/36731 11/1996
 WO WO 96/36732 11/1996
 WO WO 97/08306 3/1997
 WO WO 97/16699 5/1997
 WO WO 97/33000 9/1997
 WO WO 97/37041 10/1997
 WO WO 97/42348 11/1997
 WO WO 97/43617 11/1997
 WO WO 98/12355 3/1998
 WO WO 98/20019 5/1998
 WO WO 98/20020 5/1998
 WO WO 98/20166 5/1998
 WO WO 98/54751 12/1998

FOREIGN PATENT DOCUMENTS

EP 0215669 3/1987
 EP 0217403 4/1987
 EP 0219695 4/1987
 EP 0253578 1/1988
 EP 0264036 4/1988
 EP 0360677 3/1990
 EP 0420053 9/1990
 EP 0392546 10/1990
 EP 0396116 11/1990
 EP 0412883 2/1991
 EP 0440193 8/1991
 EP 0455905 11/1991
 EP 0456304 11/1991
 EP 0544450 11/1991
 EP 544450 * 11/1992
 EP 0684315 11/1995
 EP 0701001 3/1996
 EP 0937097 8/1999
 GB 2017105 3/1979
 GB 2017105 10/1979
 JP 63-230086 9/1988
 JP 2215399 8/1990
 JP 6294796 10/1994
 WO WO 84/02579 7/1984
 WO WO 88/10313 12/1988
 WO WO 89/09282 10/1989
 WO WO 89/09406 10/1989

OTHER PUBLICATIONS

Urdea, M. et al "A comparison of non-radioisotopic hybridization assay ..." Nucleic Acid Res. (1988) vol. 16, No. 11, pp. 4937-4956.*
 Van Ness, J. et al "A versatile solid support system for oligodeoxynucleotide ..." Nucleic Acid Res. (1991) vol. 19, No. 12, pp. 3345-3349.*
 E-mail on Oct. 26, 2005 from Aaron Scalia to Bruce Grant.
 Albretsen et al., "Applications of Magnetic Beads with Covalently Attached Oligonucleotides in Hybridization: Isolation and Detection of Specific Measles Virus mRNA from a Crude Cell Lysate", Anal. Biochem., 189:40-50, 1990.
 Alderton et al., Magnetic bead purification of M13 DNA sequencing templates, Anal. Biochem. 201:166-169 (1992).
 Allin, S.M. and Shuttleworth, S.J., "The Preparation and First Application of a Polymer Supported "Evans" Oxazolidinone", Tetrahedron Lett., 37(44):8023-8026 (1996).
 Arlinghaus et al., Applications of resonance ionization spectroscopy for semiconductor, environmental and biomedical analysis, and for DNA sequencing, SPIE, vol. 1435, Opt. Methods Ultrasensitive Detect. Anal. Tech. Appl. pp. 26-35 (1991).
 Arshady, R, Beaded polymer supports and gels: 1. Manufacturing techniques, Journal of Chromatography, 586:181-197 (1991).
 Arshady, R, Beaded polymer supports and gels: 11. Physico-chemical criteria and functionalization, Journal of Chromatography, 586:199-219 (1991).

(56)

References Cited

OTHER PUBLICATIONS

- Backes, B.J. et al., "Activation Method to Prepare a Highly Reactive Acylsulfonamide "Safety Catch" Linker for Solid-Phase Synthesis" 118:3055-3056 (1996).
- Bains, DNA sequencing by mass spectrometry: Outline of a potential future application, *Chimicaoggi* 9:13-16 (1991).
- Bains, Setting a sequence to sequence a sequence, *Biotechnology* 10:757-758 (1992).
- Bannwarth, Solid-phase synthesis of oligodeoxynucleotides containing phosphoramidate internucleotide linkages and their specific chemical cleavage, *Helvetica Chimica Acta* 71:1517-1527 (1988).
- Barrell, DNA sequencing: present limitations and prospects for the future, *FASEB J.* 5:40-45 (1991).
- Batista-Viera et al., A new method for reversible immobilization of thiol biomolecules based on solid-phase bound thiol-sulfonate groups, *App. Biochem and Biotech.* 31:175-195 (1991).
- Beaucage et al., The synthesis of modified oligonucleotides by the phosphoramidite approach and their applications, *Tetrahedron* 49:6123-6194 (1993).
- Beck and Koster, Applications of dioxetane chemiluminescent probes to molecular biology, *Anal. Chem.* 62:2258-2270 (1990).
- Beck et al., Chemiluminescent detection of DNA: application of DNA sequencing and hybridization, *Nucleic Acids Res.* 17(13):5115-5123 (1989).
- Bray, A.M. et al., "Direct Cleavage of Peptides from a Solid Support into Aqueous Buffer. Application in Simultaneous Multiple Peptide Synthesis", *J. Org. Chem.*, 56:6659-6666 (1991).
- Brennan et al., New methods to sequence DNA by mass spectrometry, *SPIE*, vol. 1206, *New Technol. Cytom. Mol. Biol.* pp. 60-77 (1990).
- Broude et al., Enhanced DNA sequencing by hybridization, *Proc. Natl. Acad. Sci.* 91:3072-3076 (1994).
- Brown et al., A single-bead decode strategy using electrospray ionization mass spectrometry and a new photolabile linker: 3-Amino-3-(2-nitrophenyl)propionic acid, *Molec. Diversity* 1:4-12 (1995).
- Burgess, K. et al., "An Approach to Photolabile, Fluorescent Protecting Groups", *J. Org. Chem.*, 62:5165-5168 (1997).
- Certified English language translation of "Correspondence between R. Mandrand and Mr. Daniel dated; Mar. 14, May 3, and Dec. 5, 1977".
- Certified English language translation of International PCT Publication WO 92/104465. (1992).
- Certified English language translation of the Statement of Grounds Opposition "Annex 1—Grounds." Original French Language Document dated May 7, 2002.
- Chen and Seeburg, Supercoil sequencing: A fast and simple method for sequencing plasmid DNA, *DNA* 4(2):165-170 (1985).
- Chrissey et al., Covalent attachment of synthetic DNA to self-assembled monolayer films, *Nucl. Acids Res.* 24:3031-3039 (1996).
- Chrissey et al., Fabrication of patterned DNA surfaces, *Nucl. Acids Res.* 24:3040-3047 (1996).
- Christensen, L. et al "Solid-phase synthesis of peptide nucleic acids" *J. Pept. Res.* (1995) vol. 3, pp. 175-183.
- Church et al. "Multiplex DNA Sequencing", *Science* 240:185-188 (1988).
- Communication of Notice of Opposition (R. 57(1) EPC), with Grounds of Opposition, dated Jun. 24, 2002, for European Patent EP 0 937 097 B1.
- Correspondence between R. Mandrand and Mr. Daniel dated; Mar. 14, May 3, and Dec. 5, 1977.
- Correspondence regarding vol. of wells in 611F96 plates. Email Dated Oct. 26, 2005.
- Crain, "Mass spectrometric techniques in nucleic acid research", *Mass Spear. Rev.* 9:505-554 (1990).
- Curtis et al., *IEEE Transactions on Nanobioscience*, 3(1):61-65 (2004).
- Damha, Masad J. et al.; An Improved Procedure for Derivatization of Controlled-Pore Glass Beads for Solid-Phase Oligonucleotide Synthesis, *Nucleic Acids Research* 18(13):3813-3821 (1990).
- DeGrado, W.F. and Kaiser, E.T., "Polymer-Bound Oxime Esters as Supports for Solid-Phase Peptide Synthesis. Preparation of Protected Peptide Fragments", *J. Org. Chem.*, 45:1295-1300 (1980).
- Derwent Publications, WPI Acc. No. #85-224987/198942, citing International PCT Application No. WO 89/09406 published Oct. 5, 1989.
- Derwent Publications, WPI Acc. No. #88-311964/198844, citing Japanese Patent No. JP63230086 published Sep. 26, 1988.
- Derwent Publications, WPI Acc. No. #90-108917/199015, citing European Patent No. EP0360677 published Mar. 28, 1990.
- Derwent Publications, WPI Acc. No. #90-133198/199018, citing German Patent No. DE3930312 published Apr. 26, 1990.
- Derwent Publications, WPI Acc. No. #90-302767/199040, citing Japanese Patent No. JP221 5399 published Aug. 28, 1990.
- Derwent Publications, WPI Acc. No. #90-321790/199043, citing German Patent No. DE4011991 published Oct. 18, 1990.
- Dolitzky et al. , "Synthesis, Characterization, and Use of Immobilized Polyacrolein Microspheres in Diagnostics: A Model Determination of α_1 -Antitrypsin in Human Serum", *Anal. Biochem.*, 220:257-267, 1994.
- Drmanac, et al., Sequencing of megabase plus DNA by hybridization: Theory of the method, *Genomics* 4:114-128 (1989).
- Eckstein and Goody, Synthesis and properties of diastereoisomers of adenosine 5'-(0-1-thiotriphosphate) and adenosine 5'-(0-2-thiotriphosphate), *Biochemistry* 15(81):1685-1691 (1976).
- Eckstein, F., Phosphorothioate analogues of nucleotides, *Accounts Chem. Res.* 12:204-210 (1979).
- Eckstein, Nucleoside phosphorothioates, *Ann. Rev. Biochem.* 54:367-402 (1985).
- European Patent Office Decision Dated: Mar. 11, 2008 for European Patent No. 0 937 097 based on PCT/US97/20194.
- Frank and Koster, DNA chain length and the influence of base composition on electrophoretic mobility of oligodeoxyribonucleotides in polyacrylamide-gels, *Nucl. Acids Res.* 6:2069-2087 (1979).
- Fu et al., "A DNA sequencing strategy that requires only five bases of known terminal sequencing for priming", *Proc. Natl. Acad. Sci.* 92:10162-10166 (1995).
- Fujita et al., Surprising lability of biotin-streptavidin bond during transcription of biotinylated DNA bound to paramagnetic beads, *BioTechniques* 14:608-617 (1993).
- Gait, M.J., ed., "Oligonucleotide Synthesis : A Practical Approach", IRL Practical Approach Series, IRL Press, Oxford, 1984, Table of contents only.
- Gayo, L.M. and Suto, M.J., "Traceless Linker: Oxidative Activation and Displacement of a Sulfur-Based Linker", *Tetrahedron Lett.*, 38(2):211-214 (1997).
- Gehring et al., "Enzyme-linked immunomagnetic electrochemical detection of Salmonella typhimurium", *J. Immun. Methods*, 195:15-25, 1996.
- Ghosh and Musso, Covalent attachment to solid supports, *Nucl. Acids Res.* 15:5353-5372 (1987).
- Gildea et al., A versatile acid-labile linker for modification of synthetic biomolecules, *Tetrahedron Letters* 31:7095-7398 (1990).
- Goldmacher et al., Photoactivation of toxin conjugates, *Bioconjugate Chem.* 3:104-107, (1992).
- Greene, *Protective Groups in Organic Synthesis*, 2nd Edition, Wiley & Sons, Table of Contents (1991).
- Han, Y. et al., "Silicon Directed ipso-Substitution of Polymer Bound Arylsilanes: Preparation of Biaryls via the Suzuki Cross-Coupling Reaction", *Tetrahedron Lett.*, 37(16):2703-2706 (1996).
- Hayashi et al., Immobilization of thiol proteases onto porous poly-(vinyl alcohol) beads, *Polymer Journal*, 25:5, 489-497 (1993).
- Hazum et al., A photocleavable protecting group for the thiol function of cysteine, *Pept., Proc. Eur. Pept. Symp.*, 16th, Brunfeldt, K (Ed), pp. 105-110 (1981).
- Hermanson, *Bioconjugate Techniques*, Academic Press (1996), TOC only.
- Higuchi et al., A general method of in vitro preparation and mutagenesis of DNA fragments: Study of protein and DNA interactions, *Nucleic Acids Res.* 16:7351-7367 (1988).
- Higuchi et al., Kinetic PCR analysis: Real-time monitoring of DNA amplification reactions, *BioTechnology* 11:1026-1030 (1993).

(56)

References Cited

OTHER PUBLICATIONS

- Hillenkamp and Ehring, Laser desorption mass spectrometry Part 1: Basic mechanisms and techniques, *Mass Spectrometry in the Biological Sciences: A tutorial*, pp. 165-179 (1992).
- Hillenkamp et al., "Matrix Assisted UV Laser Desorption/ionization: A New Approach to Mass Spectrometry of Large Biomolecules", *Bio Mass Spectr.*, Burlingame and McCloskey (eds.), pp. 49-61, Elsevier Science Publishers B.V., Amsterdam (1989).
- Hobbs and Eckstein, A general method for the synthesis of 2'-azido-2'-deoxy- and 2'-amino-2'-deoxyribofuranoxyl purines, *J. Org. Chem.* 42:714-719 (1976).
- Homes and Korsnes, Magnetic DNA hybridization of oligonucleotide probes attached to superparamagnetic beads and their use in the isolation of Poly(A) mRNA from eukaryotic cells, *GATA* 7:145-150, (1990).
- Hultman et al., Direct solid phase sequencing of genomic and plasmid DNA using magnetic beads as solid support, *Nucl. Acids Res.* 17:4937-4946 (1989).
- Huth-Fehre et al., Matrix-assisted laser desorption mass spectrometry of oligodeoxythymidic acids, *Rapid Communications in Mass Spectrometry* 6(3):209-213 (1992).
- Hyman, A new method of sequencing DNA, *Anal. Biochem.* 174:423-436 (1988).
- Innis et al., editors, *PCR Protocols: A guide to methods and applications*, Academic Press, San Diego (1990), TOC only.
- Innis et al., DNA sequencing with *Thermus aquaticus* DNA polymerase and direct sequencing of polymerase chain reaction-amplified DNA, *Proc. Natl. Acad. Sci. USA* 85:9436-9440 (1988).
- Jacobson, et al., Applications of mass spectrometry to DNA sequencing, *GATA* 8:223-229 (1991).
- Jett et al., "High-Speed DNA Sequencing: An Approach Based Upon fluorescence Detection of Single Molecules", *J. Bio Struct & Dynam.* 7(2):301-09 (1989).
- Jurinke, C. et al., "Recovery of Nucleic Acids from Immobilized Biotin-Streptavidin Complexes using Ammonium Hydroxide and Applications in MALDI-TOF Mass Spectrometry", *Anal. Chem.*, 69:904-910 (1997).
- Kaldor, S.W. et al., "Use of Solid Supported Nucleophiles and Electrophiles for the Purification of Non-Peptide Small Molecule Libraries", *Tetrahedron Lett.*, 37(40):7193-7196 (1996).
- Khrapko et al., "A method for DNA sequencing by hybridization with oligonucleotide matrix", *J. DNA Sequencing and Mapping* 1:375-388 (1991).
- Khrapko et al., An oligonucleotide hybridization approach to DNA sequencing, *FEB* 256(1,2):118-122 (1989).
- Kirpekar et al., "7-deaza purine bases offer a higher ion stability in the analysis of DNA by matrix-assisted laser desorption/ionization mass spectrometry" *Rapid Commun. Mass Spectrom.* 9:525-531 (1995).
- Koster et al. Oligonucleotide synthesis and multiplex DNA sequencing using chemiluminescent detection, *Nucl. Acids Res.*, Symposium Series No. 24:318-321 (1991).
- Koster et al., "A strategy for rapid and efficient DNA sequencing by mass spectrometry", *Nature Bio* 14:1123-1128 (1996).
- Koster et al., N-acyl protecting groups for deoxynucleotides: A quantitative and comparative study, *Tetrahedron* 37:363-369 (1981).
- Koster et al., Well-defined insoluble primers for the enzymatic synthesis of oligo- and polynucleotides, *Hoppe Seylers Z. Physiol. Chem.* 359(11):1579-1589 (1978).
- Koster, H. et al., "Polymer Support Oligonucleotide Synthesis—XV: Synthesis of Oligodeoxynucleotides on Controlled Pore Glass (CPG) using Phosphate and a new Phosphotriester Approach", *Tetrahedron*, 40(1):103-112 (1984).
- Koster, H. et al., "Some Improvements in the Synthesis of DNA of Biological Interest", *Nucl. Acids Res.*, Symposium Ser. 7:39-59 (1980).
- Kozal et al., "Extensive polymorphisms observed in HIV-1 clade B protease gene using high-density oligonucleotide arrays", *Nature Medicine* 2(7):753-759 (1996).
- Kumar, G. and Poonian, M.S., "Improvements in Oligodeoxyribonucleotide Synthesis: Methyl N,N-Dialkylphosphoramidite Dimer Units for Solid Support Phosphite Methodology", *J. Org. Chem.*, 49:4905-4912 (1984).
- Kussmann, et al., Matrix-assisted laser desorption/ionization mass spectrometry sample preparation techniques designed for various peptide and protein analytes, *J. Mass Spec.* 32:593-601 (1997).
- Labeit et al., Laboratory methods: A new method of DNA sequencing using α -thiotriphosphates, *DNA* 5:173-177 (1986).
- Lamture et al., Direct detection of nucleic acid hybridization on the surface of a charge coupled device, *Nucl. Acids Res.* 22:2121-2125 (1994).
- Landegren et al., "DNA Diagnostics—Molecular techniques and automation", *Science* 242:229-237 (1988).
- Leznoff, C.C. and Wong, J.Y., "The Use of Polymer Supports in Organic Synthesis. The Synthesis of Monotriyl Ethers of Symmetrical Diols", *Can. J. Chem.*, 50:2892-2893 (1972).
- Li et al., "Analysis of single mammalian cell lysates by mass spectrometry", *J. Am. Chem. Soc.* 118:11662-11663 (1996).
- Li et al., "High-Resolution MALDI Fourier Transform Mass Spectrometry of Oligonucleotides", *Anal Chem* 68(13):2090-2096 (1996).
- Little et al., "Direct detection of synthetic and biologically generated double-stranded DNA by MALDI-TOF MS", *J. Mass Spec* 17:1-8 (1997).
- Little et al., "MALDI on a Chip: Analysis of Arrays of Low-Femtomole to Subfemtomole Quantities of Synthetic Oligonucleotides and DNA Diagnostic Products Dispensed by a Piezoelectric Pipet", *Anal chem* 69:4540-4546 (1997).
- Little et al., "Mass spectrometry from miniaturized arrays for full comparative DNA analysis", *Nature Med* 3(12):1413-1416 (1997).
- Livanah, O. et al. "Three-dimensional structures of avidin and the avidin-biotin complex," *PNAS* (1993) vol. 90, pp. 5076-5080.
- Lloyd-Williams, P. et al., "Convergent Solid-Phase Peptide Synthesis", *Tetrahedron*, 49(48):11065-11133 (1993).
- Locasio and Gaitan "Integrated Silicon Microheating Elements using Silicon-on-Plastic Drop in Functionality," *Proceedings uTAS 2000 Conference*; Twente, The Netherlands, Proceeding microTAS Conference, Netherlands May 14-18, 2000. Conference Article.
- Lorsbach, B.A. et al., "Reissert-Based "Traceless" Solid-Phase Synthesis: Isoquinoline, and Isoxazoline-Containing Heterocycles", *J. Org. Chem.*, 61:8716-8717 (1996).
- Lund et al., Assessment of methods for covalent binding of nucleic acids to magnetic beads, Dynabeadstm and the characteristics of the bound nucleic acids in hybridization reactions, *Nucl. Acids Res.* 16:10861-10880 (1988).
- Manoharan et al., A 2'-O-thiol tether in the ribose moiety of nucleic acids for conjugation chemistry, *Gene*, 149:147-156 (1994).
- Mansion, J.E., *Harrap's Shorter French and English Dictionary*. 1967, pp. P:26 and W:II-W12, Part One, French-English, Ed. Ledesert and Ledesert, Pub. Bordas, Paris in association with George G. Harrap & Company Ltd.
- Margel et al., "Surface Modification. I. Polyacrolein Microspheres Covalently Bonded onto Polyethylene", *J. Poly. Sci.*, 30:1103-1110, 1992.
- Matteucci et al., Synthesis of deoxyoligonucleotides on a polymer support, *J. A. Chem. Soc.* 103:3185-3191, 1981.
- Maxam and Gilbert, Sequencing end-labeled DNA with base-specific chemical cleavages, *Methods in Enzymology* 65:499-560 (1980).
- McCray and Trentham, "Properties and uses of photoreactive caged compounds", *Annu. Rev. Biophys. Biophys. Chem.* 18:239-270 (1989).
- Minutes and associated documents regarding European Patent Office Opposition Proceedings conducted Feb. 14, 2008.
- Molecular Cloning: A laboratory manual*, 2nd, ed., Ch. 11: Synthetic oligonucleotide probes, Sambrook, Cold Spring Harbor Laboratory Press New York, pp. 11.1-11.61(1989).
- Morphy, J.R. et al., "A Novel Linker Strategy for Solid-Phase Synthesis", *Tetrahedron Lett.*, 371181:3209-3212 (1996).
- Morrison and Boyd, *Organic Chemistry*, 5th ed., 1987, p. 1.
- Murray, "DNA sequencing by mass spectrometry", *J. Mass. Spect.* 31:1203-1215 (1996).

(56)

References Cited

OTHER PUBLICATIONS

- Nakamaye et al., "Direct sequencing of polymerase chain reaction amplified DNA fragments through the incorporation of deoxynucleoside α -thiotriphosphates", *Nucleic Acids Res.* 16(21):9947-9959 (1988).
- Nelson et al., "Volatilization of High Molecular Weight DNA by Pulsed Laser Ablation of Frozen Aqueous Solutions", *Science* 246:1585-1587 (1989).
- Nelson et al., Time-of-flight mass spectrometry of nucleic acids by laser ablation and ionization from a frozen aqueous matrix, *Rapid Communications in Mass Spectrometry* 4:348-351 (1990).
- Newlander, K.A. et al., "Simple Silyl Linker for the Solid Phase Organic Synthesis of Aryl-Containing Molecules", *J. Org. Chem.*, 62:6726-6732 (1997).
- Newton et al., The production of PCR products with 5' single-stranded tails using primers that incorporate novel phosphoramidite intermediates, *Nucl. Acids. Res.* 21:1155-1162 (1993).
- Nikiforov and Rogers, The use of 96-well polystyrene plates for DNA hybridization-based assays: An evaluation of different approaches to oligonucleotide immobilization, *Anal. Biochem.* 227:201-209 (1995).
- Nordhoff et al., "Ion stability of nucleic acids in infrared matrix-assisted laser desorption/ionization mass spectrometry", *Nucl. Acids Res.* 21(15):3347-3357 (1993).
- Nordoff et al., "Matrix-assisted laser desorption/ionization mass spectrometry of nucleic acids with wavelength in the ultraviolet and infrared", *Rapid Comm. Mass Spectrom.* 6:771-776 (1992).
- Norton, J.C. et al., "Targeting Peptide Nucleic Acid-Protein Conjugates to Structural Features within Duplex DNA", *Bioorg. Med. Chem.*, 3(4):437-445 (1995).
- O'Donnell-Maloney et al., "The development of microfabricated arrays for DNA sequencing and analysis" TIBTECH, 14:401-407 (1996).
- O'Donnell et al., "High-Density, Covalent Attachment of DNA to Siliccn Wafers for Analysis by MALDI-TOF Mass Spectrometry", *Analytical Chemistry* 69(13):2438-2443 (1997).
- O'Donnell et al., "MassArray as an Enabling Technology for the Industrial-Scale Analysis of DNA", *Genetic Engineering News* 17(21):39-41, (1997).
- O'Donnell-Maloney et al., "Microfabrication and array technologies for DNA sequencing and diagnostics", *Genetic Analysis: Biomolecular Engineering* 13:151-157 (1996).
- Olejnik, J. et al., "Photocleavable biotin phosphoramidite for 5'-end-labelling, affinity purification and phosphorylation of synthetic oligonucleotides", *Nucl. Acids Res.*, 24(2):361-366 (1996).
- Oligonucleotides and Analoues, A Practical Approach, F. Eckstein, editor, IRL Press Oxford, Table of Contents (1991).
- Oligonucleotides and Analoues: A Practical Approach, Eckstein, ed., Oxford University Press Ch. 3, pp. 49-59, 137-139, 255-259 (1991).
- Opponent Letter, Nov. 2, 2005.
- Opposition Division Communication Re: Opponent Opposition, Jun. 7, 2004.
- Opposition Division Preliminary Opinion, Apr. 2, 2003.
- Opposition Division Second Opinion, Mar. 18, 2004.
- Opposition Proceedings New Main request, May 24, 2004.
- Opposition Proceedings New Main request, Oct. 13, 2003.
- Overberg et al., "Laser Desorption Mass Spectrometry. Part II Performance and Applications of Matrix-Assisted Laser Desorption/Ionization of Large Biomolecules", *Mass Spect in the Biolog Science: A Tutorial* 181-197 (1992).
- Patek, M. and Lebl, M., "Safety-Catch Anchoring Linkage for Synthesis of Peptide Amides by Boc / Fmoc Strategy", *Tetrahedron Lett.*, 32(31):3891-3894 (1991).
- Patentee's Observations on the Opposition filed with the European Patent Office on Jan. 3, 2003.
- Pieles et al., Matrix-assisted laser desorption ionization time-of-flight mass spectrometry: a powerful tool for the mass and sequence analysis of natural and modified oligonucleotides, *Nucleic Acids Res.* 21(14):3191-3196 (1993).
- Pierce Catalog, pp. T123-T154, 1994.
- Pierce ImmunoTechnology Catalog, p. 57 (1993).
- Plunkett, M.J. and Ellman, WA., "A Silicon-Based Linker for Traceless Solid-Phase Synthesis", *J. Org. Chem.*, 60:6006-6007 (1995).
- Pon, et al., Derivation of controlled pore glass beads for solid phase oligonucleotide synthesis, *BioTechniques*, 6:8, 770-775 (1988).
- Raftery, et al., Characterization of a mutant recombinant S100 protein using electrospray ionization mass spectrometry. *Rapid Comm. Mass Spec.* 11:405-409 (1997).
- Rasmussen et al., Covalent immobilization of DNA onto polystyrene microwells: The molecules are only bound at the 5'end, *Anal. Biochem.* 198:138-142 (1991).
- Response to Oral Proceedings Summons, Nov. 7, 2005.
- Rink, "Solid-phase synthesis of protected peptide fragments using a trialkoxy-diphenyl-methlester resin", *Tetrahedron Lett.* 28:3787-3790 (1987).
- Rolfs et al., PCR: Clinical Diagnostics and Research, Springer—Verlag (1992), TOC only.
- Routledge, A. et al., "The Use of a Dithiane Protected Benzoin Photolabile Safety Catch Linker for Solid Phase Synthesis", *Tetrahedron Lett.*, 38(7):1227-1230 (1997).
- Running and Urdea, A procedure for productive coupling of synthetic oligonucleotides to polystyrene microtiter wells for hybridization capture, *Biotechniques* 8:276-277 (1990).
- Ruppert et al., "A rapid and high throughput method for plasmid isolations", Presented: Automation in Mapping and DNA Sequencing Conference, Aug. 31-Sep. 2, 1994.
- Ruppert et al., "Preparation of plasmid DNA as Sequencing Templates in a Microliter Plate Format" Paper presented, Cold Spring Harbor Laboratory, N.Y., USA May 10-14, 1995.
- Ruppert et al., A filtration Method for plasmid isolation using microtitre filter plates, *Anal. Biochem.*, 230:130-134, (1995).
- Saiki et al., Genetic analysis of amplified DNA with immobilized sequence-specific oligonucleotide probes, *Proc. Natl. Acad. Sci.* 86:6230-6234 (1989).
- Salmon, S.E. et al., "Discovery of Biologically Active Peptides in Random Libraries: Solution Phase Testing after Staged Orthogonal Release from Resin Beads", *Proc. Natl. Acad. Sci. USA*, 90:11708-11712 (1993).
- Sanger et al., DNA sequencing with chain-terminating inhibitors, *Proc. Natl. Acad. Sci.* 74:5463-67 (1977).
- Sasaki et al., Introduction of an azide group into some uridine derivatives via 2',3'-benzoxonium and 2',3'-azidonium intermediates, *J. Org. Chem.* 41:3138-3143 (1976).
- Schneider and Chait, Increased stability of nucleic acids containing 7-deaza-guanosine and 7-deaza-adenosine may enable rapid DNA sequencing by matrix-assisted laser desorption mass spectrometry, *Nucleic Acids Res.* 23(9):1570-1575 (1995).
- Schram, Karl H., "Mass Spectrometry of Nucleic Acid Components", *Bio Appl of Mass Spect.* 34:203-287 (1990).
- Schriemer et al., "Combining Avidin-Biotin Chemistry with Matrix-Assisted Laser Desorption/Ionization Mass Spectrometry", *Anal. Chem.*, 68:3382-3387, 1996.
- Senter et al., Novel photocleavable protein crosslinking reagents and their use in the preparation of antibody-toxin conjugates, *Photochem. Photobiol.* 42:231-237, (1985).
- Sequenom Advances the Industrial Genomics Revolution with the Launch of Its DNA MassArray™ Automated Process Line", Press Release: Sep. 28, 1998, <http://www.sequenom.com/pressrelease.htm>.
- Sequenom Reports DNA MassArray™ Technology More Sensitive Than Electrophoretic Methods in Detecting Gene Mutations: Automated DNA Analysis System Can Speed Up Microsatellite Analyses", Press Release: Dec. 15, 1997, <http://www.sequenom.com/pressrelease.htm>.
- Sequenom Reports On Use of Its DNA MassArray™ Technology to Analyze Genes Associated with Alzheimer's Disease and Arteriosclerosis: Technology Has Applications in Drug Development", Press Release: Sep. 22, 1997, <http://www.sequenom.com/pressrelease.htm>.
- Sequenom Signs Agreement With Bruker-Franzen Analytik to Develop Mass Spectrometer for DNA Massarray Analysis, Press Release: Jan. 12, 1998, <http://www.sequenom.com/pressrelease.htm>.

(56)

References Cited

OTHER PUBLICATIONS

Sequenom Uses DNA MassArraytm to Sequence Section of Human Cancer-Related p53 Gene, Press Release: Mar. 27, 1998, <http://www.sequenom.com/pressrelease.htm>.

Shaler et al., "Analysis of enzymatic DNA sequencing reactions by matrix-assisted laser desorption/ionization time-of-flight mass spectrometry", *Rapid Commun Mass Spectrom* 9(10):942-947 (1995).

Shaler et al., "Effect of Impurities on the matrix-Assisted Laser Desorption Mass Spectra of Single-Stranded Oligodeoxynucleotides", *Anal. chem.* 68:576-579 (1996).

Siegert et al., "Matrix-assisted laser desorption/ionization time-of-flight mass spectrometry for the detection of polymerase chain reaction products containing 7-deazapurine moieties", *Analytical Biochemistry* 243:55-65 (1996).

Singh et al., Oligonucleotides, part 5 +: synthesis and fluorescence studies of DNA oligomers d(AT)₅ containing adenines covalently linked at C-8 with dansyl fluorophore, *Nucleic Acids Res.* 18(11):3339-3345 (1990).

Sinha et al., b-cyanoethyl N,N-dialkylamino/N-morpholinomonochloro phosphoramidites, new phosphitylating agents facilitating ease of deprotection and work-up of synthesized oligonucleotides, *Tetrahedron Lett.* 24:5843-5846 (1983).

Sinha et al., Polymer support oligonucleotide synthesis XVIII: use of ,S-cyanoethyl-N,N-dialkylamino-/N-morpholino phosphoramidite of deoxynucleosides for the synthesis of DNA fragments simplifying deprotection and isolation of the final product, *Nucleic Acids Res.* 12:4539-4557 (1984).

Slim et al., Configurationally defined phosphorothioate-containing oligoribonucleotides in the study of the mechanism of cleavage of hammerhead ribozymes, *Nucleic Acids Res.* 19:1183-1188 (1991).

Sproat et al., The synthesis of protected 5'-amino-2',5'-dideoxyribonucleoside-3'-O-phosphoramidites applications of 5'-amino-oligodeoxyribonucleotides, *Nucleic Acids Res.*, 15:6181-6196 (1987).

Sproat et al., The synthesis of protected 5'-mercapto-2',5'-dideoxyribonucleoside-3'-O-phosphoramidites; uses of 5'-mercapto-oligodeoxyribonucleotides, *Nucleic Acids Res.*; 15:4837-4848 (1987).

Stahl et al., Solid Phase DNA Sequencing using the Biotin-Avidin System, *Nucleic Acids Research*, vol. 16, No. 7, pp. 3025-3039 (1988).

Stedman's Medical Dictionary, 26th Edition, 1995, pp. 375-376.

Strezoska et al., DNA sequencing by hybridization: 100 bases read by a non-gel-based method, *Proc. Natl. Acad. Sci.* 88:10089-10093 (1991).

Taber's Cyclopedic Medical Dictionary, 14th edition, 1983, p. 321.

Tang et al., "Matrix-assisted laser desorption/ionization mass spectrometry of immobilized duplex DNA probes", *Nucleic Acids Research* 23:3126-3131 (1995).

Tang et al., Detection of 500-nucleotide DNA by laser desorption mass spectrometry, *Rapid Commun. Mass Spectrom.* 8:727-730 (1994).

Thuong and Asseline, Oligonucleotides attached to intercalators, photoreactive and cleavage agents, *Oligonucleotides and Analogues: A Practical Approach*, Eckstein, edr., Oxford University Press Ch. 12, pp. 283-308 (1991).

Tong et al., Solid-phase method for the purification of DNA sequencing reactions, *Anal. Chem.* 64:2672-2677, (1992).

van Maarseveen, J.II. et al., "Solid Phase Ring-Closing Metathesis: Cyclization / Cleavage Approach towards a Seven Membered Cycloolefin", *Tetrahedron Lett.*, 37(45):8249-8252 (1996).

Vorm, et al., Improved resolution and very high sensitivity in MALDI TOF of matrix surfaces made by fast evaporation, *Anal. Chem.* 66:3281-3287 (1994).

Wahlberg, J. et al "Automated magnetic preparation of DNA . . ." *Electrophoresis* (1992) vol. 13, pp. 547-551.

Wang, Solid phase synthesis of protected peptides via photolytic cleavage of the amethylphenacyl ester anchoring linkage, *J. Org. Chem.* 41(20):3258-3261 (1976).

Wellhoner et al., Uptake and concentration of bioactive macromolecules by K562 cells via the transferrin cycle utilizing an acid-labile transferrin conjugate, *J. Biol. Chem.* 256:4309-4314, (1991).

Wentrup, *Reactive Molecules*, John Wiley & Sons, Table of Contents (1984).

Williams, Time of flight mass spectrometry of DNA laser-ablated from frozen aqueous solutions: applications to the Human Genome Project, *Intl. J. Mass Spectrom. and Ion Processes* 131:335-344 (1994).

Wolter et al., Negative Ion FAB mass spectrometric analysis of non-charged key intermediates in oligonucleotide synthesis: Rapid identification of partially protected dinucleoside monophosphates, *Biomedical Environmental Mass Spectrometry* 14:111-116 (1987).

Wong, Conjugation of proteins to solid matrices, *Chemistry of Protein Conjugation and Cross-Linking* 12:295-317 (1993).

Wu et al., "Matrix-assisted Laser Desorption Time-of-flight Mass Spectrometry of Oligonucleotides Using 3-Hydroxypicolinic Acid as an Ultraviolet-sensitive Matrix", *Rapid Comm. Mass Spec* 7:142-146 (1993).

Wu et al., "Time-of-Flight Mass Spectrometry of Underivatized Single-Stranded DNA Oligomers by Matrix-Assisted Laser Desorption", *Anal. Chem.* 66:1637-1645 (1994).

Yates, III, Mass spectrometry and the age of the proteome, *J. Mass Spec.* 33:1-19 (1998).

Yen et al., Synthesis of water-soluble copolymers containing photocleavable bonds, *Makromol. Chem.* 190:69-82 (1989).

Zhang et al., Single-base mutational analysis of cancer and genetic diseases using membrane bound modified oligonucleotides, *Nucl. Acids Res.* 19:3929-3933 (1991).

Zimmermann et al., Automated preparation and purification of M13 templates for DNA sequencing, *Meth. Mol. Cell. Biol.* 1:29-34 (1989).

Zuckermann et al., Efficient methods for attachment of thiol specific probes to the 3'-ends of synthetic oligodeoxyribonucleotides, *Nucleic Acids Research*, 15:13, 5305-5321 (1987).

* cited by examiner

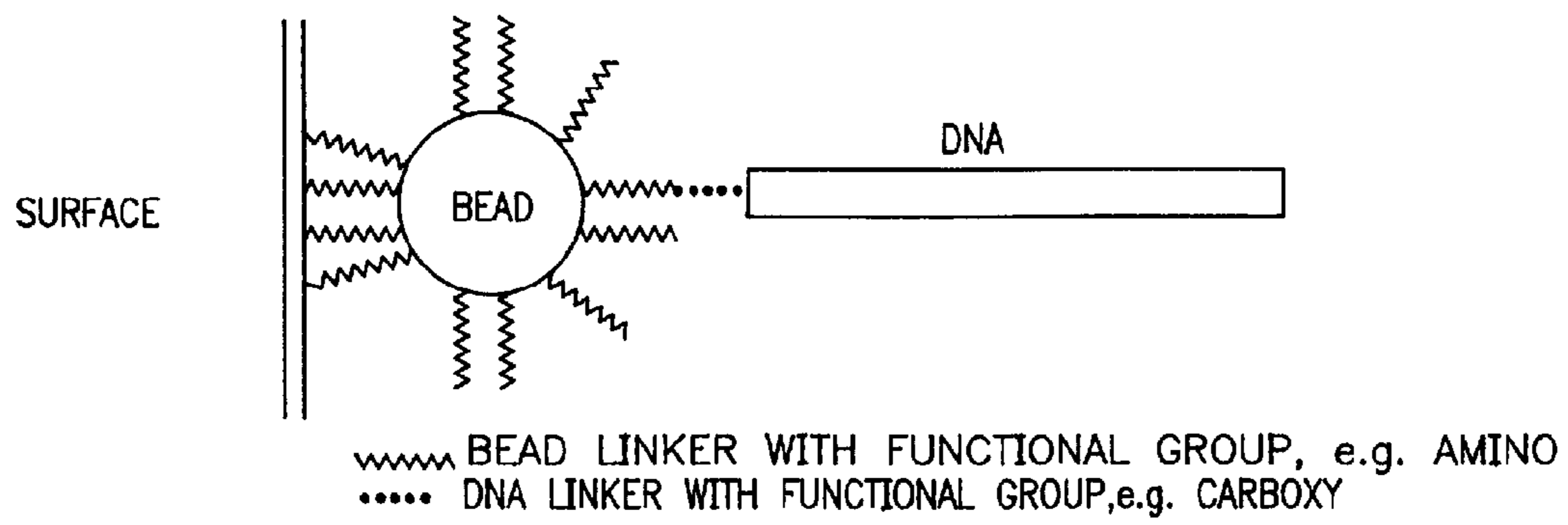

FIG. 1

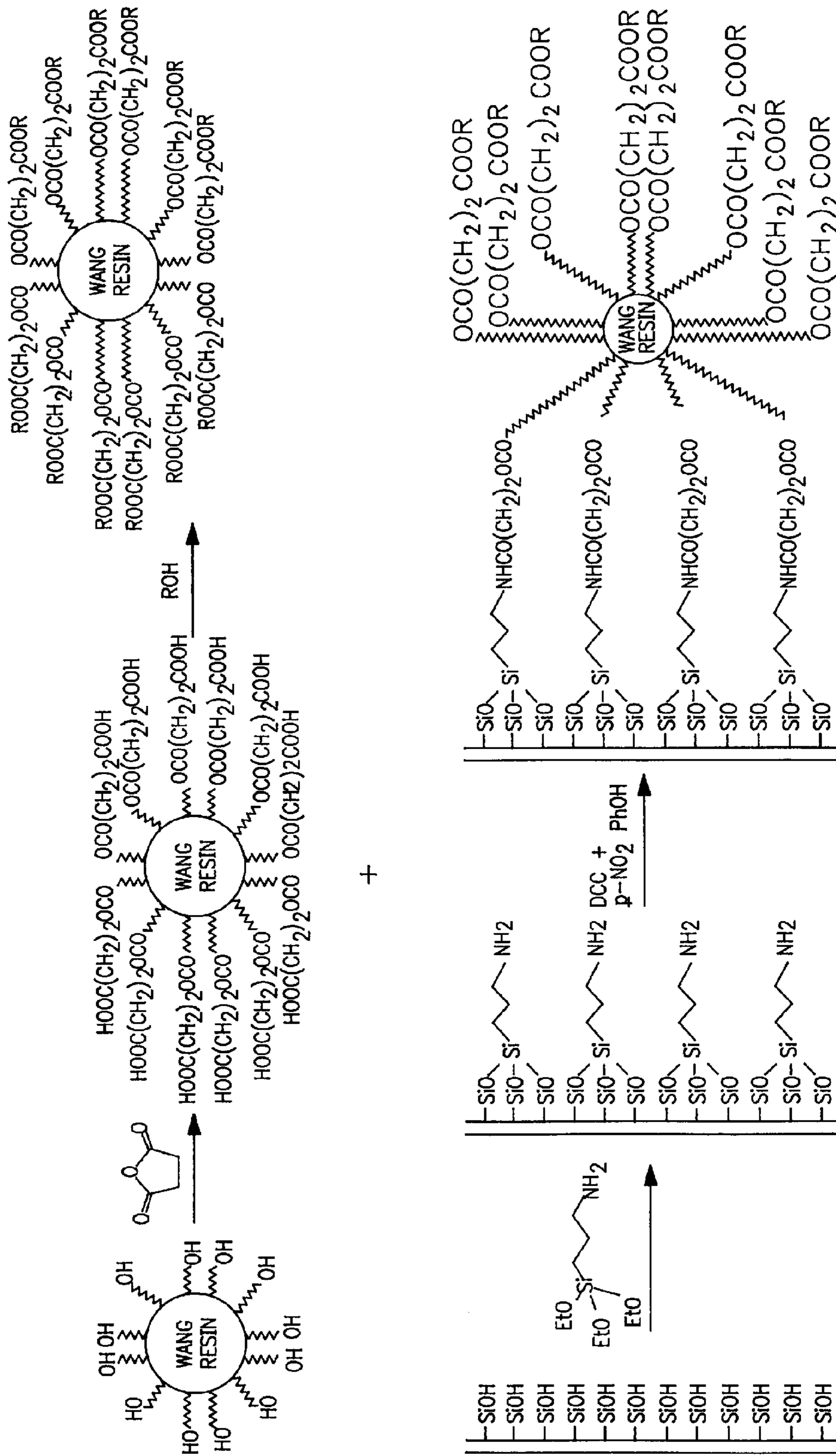
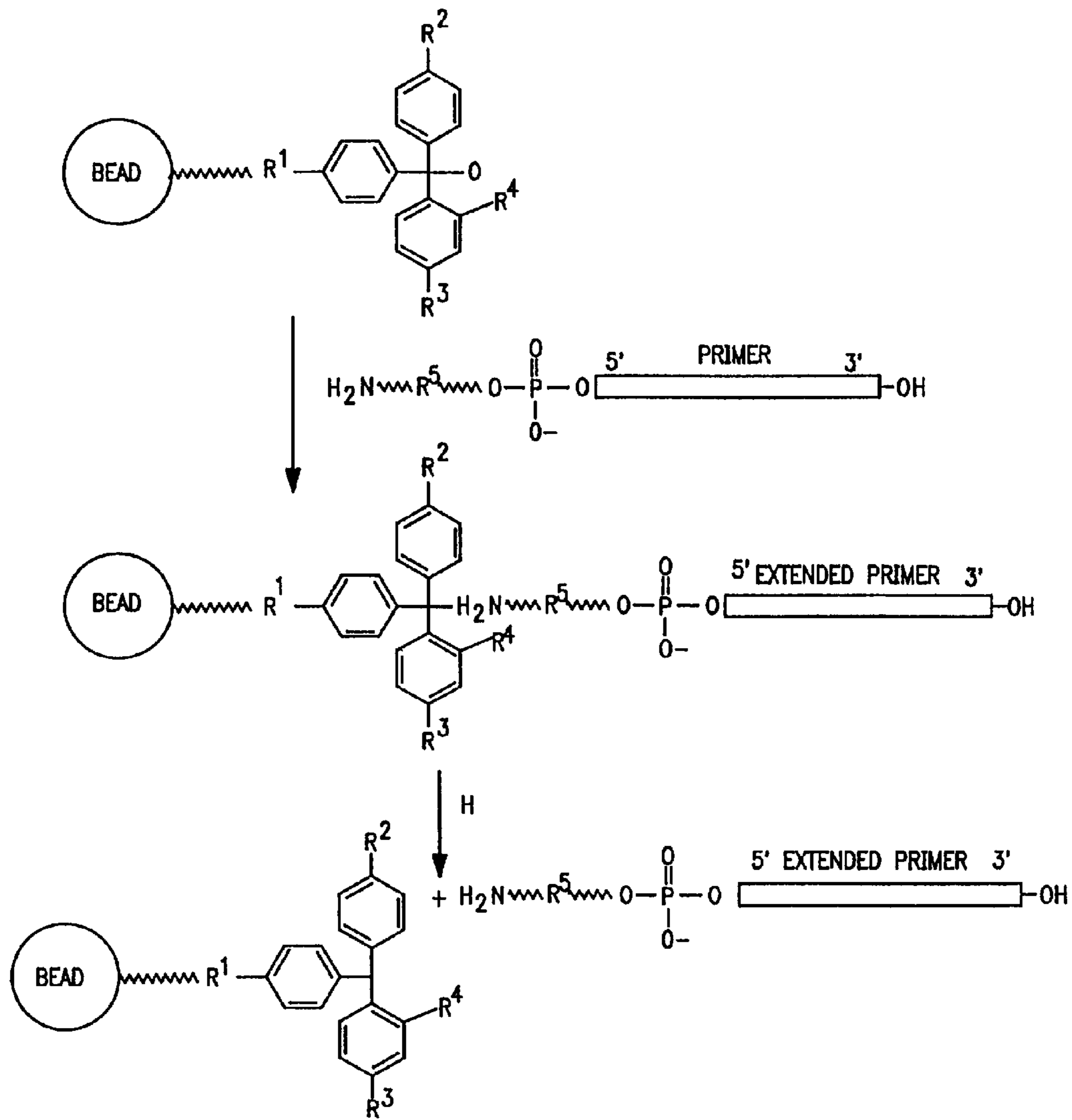

FIG. 2



$\text{R}^1 = \text{COO}; (\text{CH}_2)_n$; (para or meta)
 $\text{R}^2 = \text{MeO}; \text{H}$
 $\text{R}^3 = \text{MeO}; \text{H}$
 $\text{R}^4 = \text{Cl}; \text{H}$
 $\text{R}^5 = (\text{CH}_2)_n; (\text{CH}_2)_n \text{CONH}(\text{CH}_2)_n$

FIG. 3

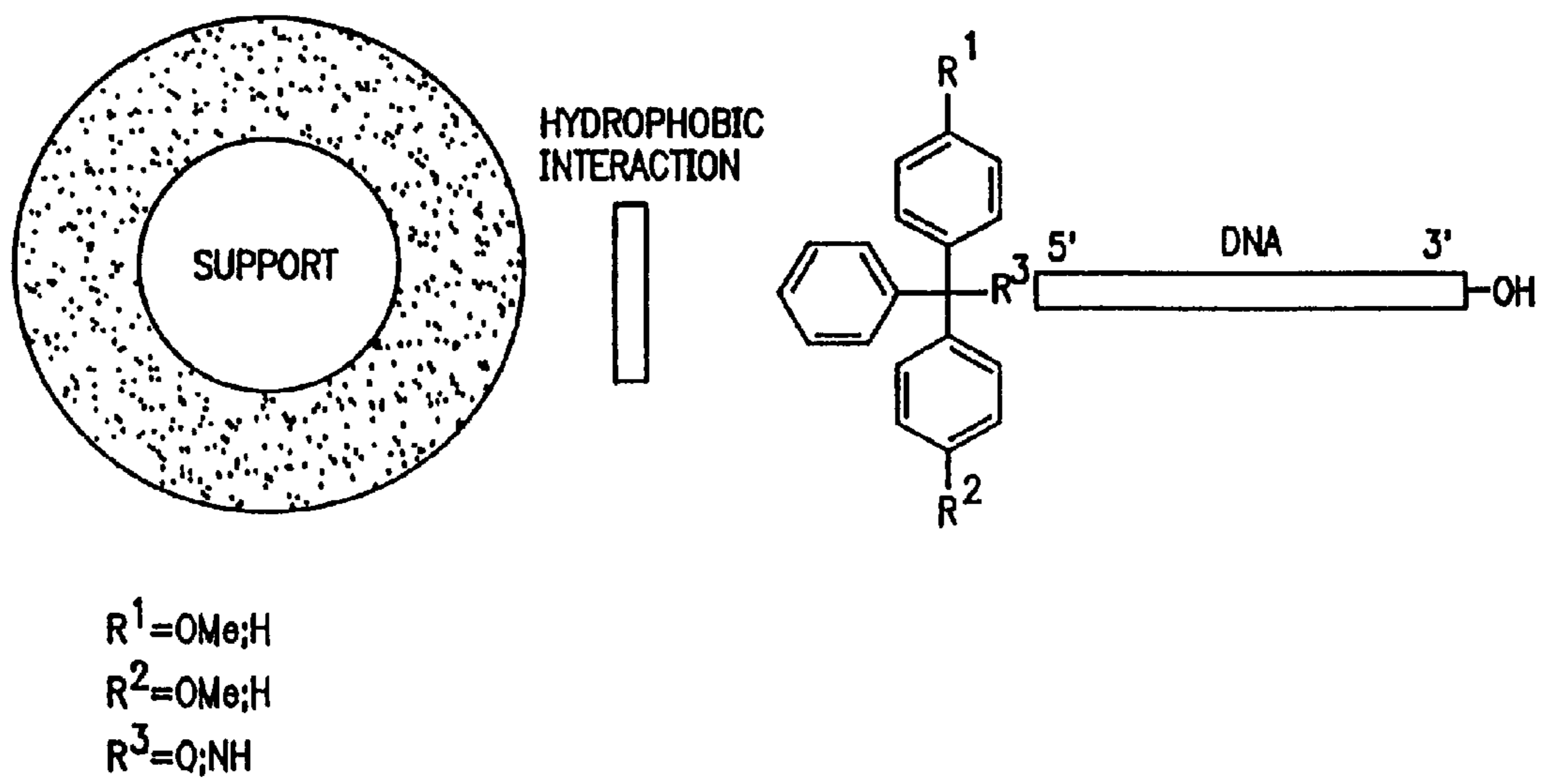

FIG. 4

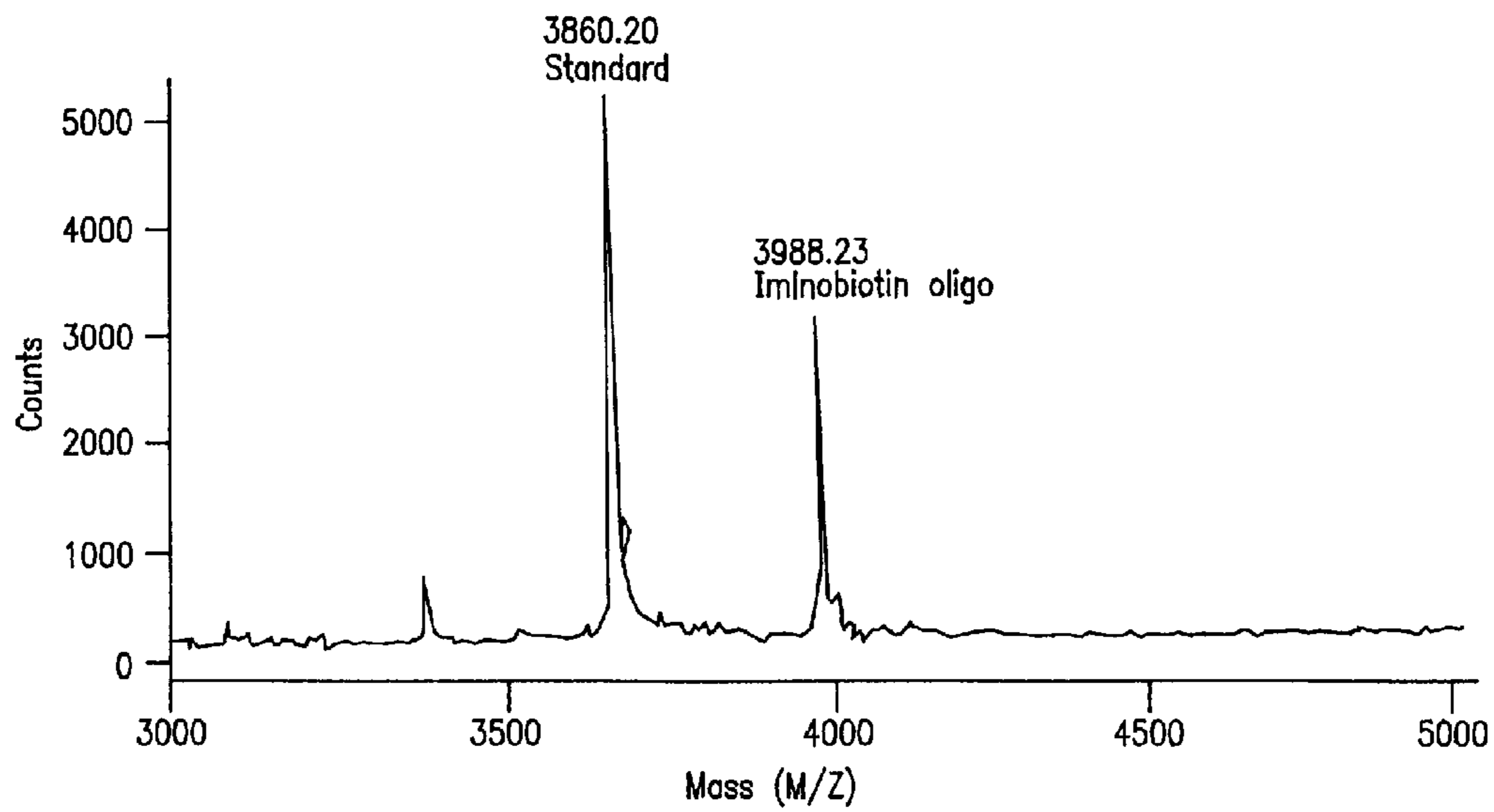

FIG. 5

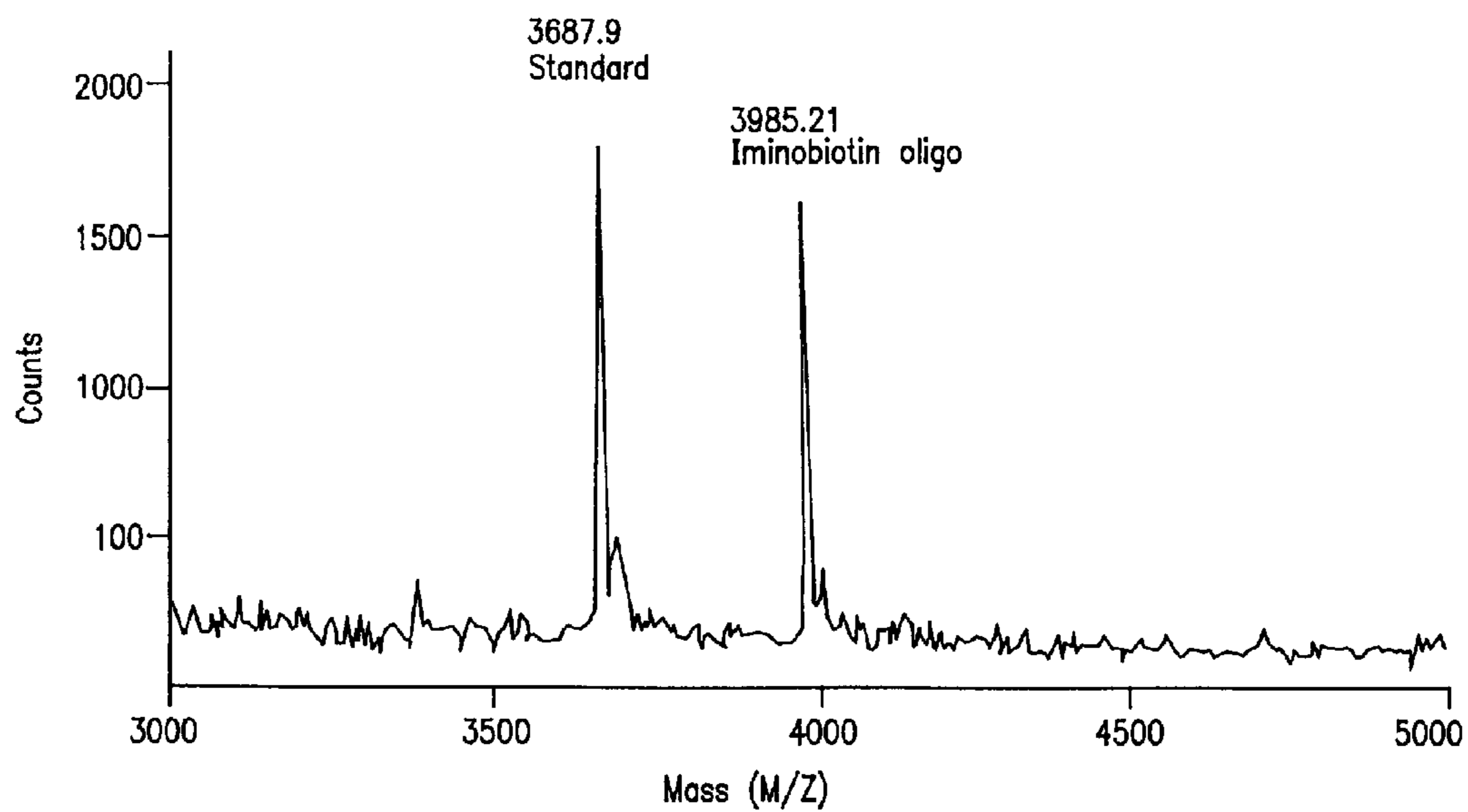

FIG. 6

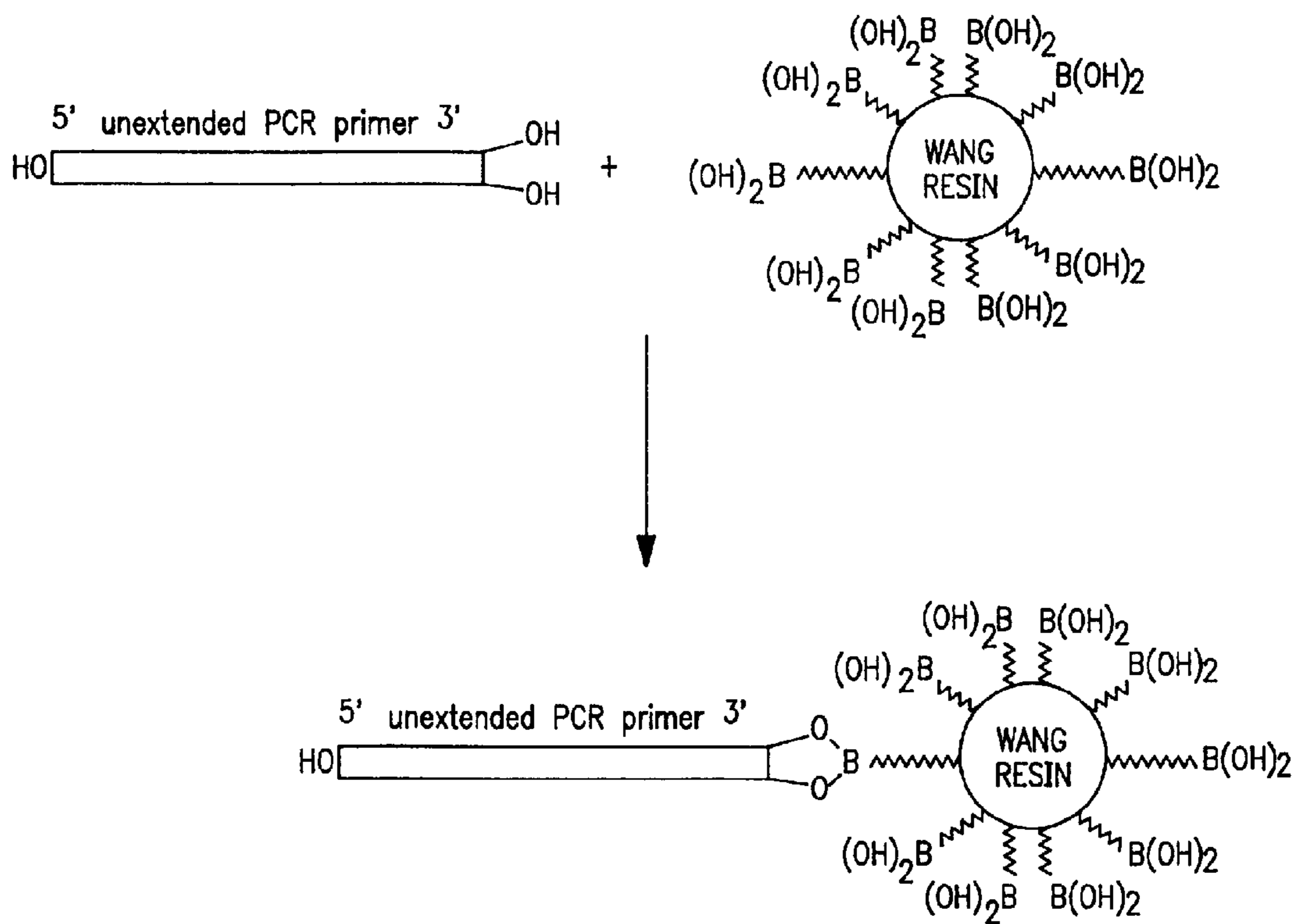

FIG. 7

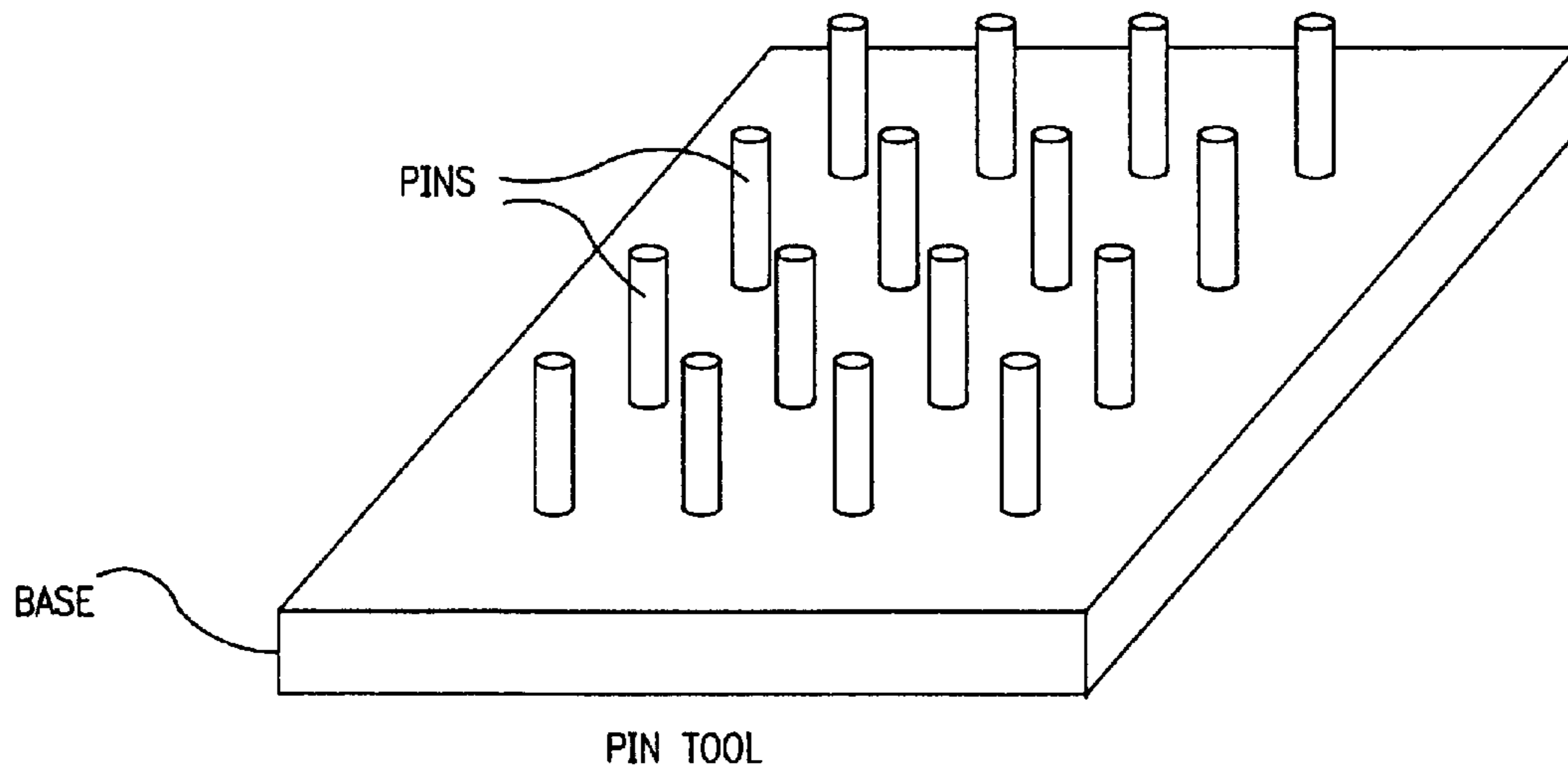

FIG. 8

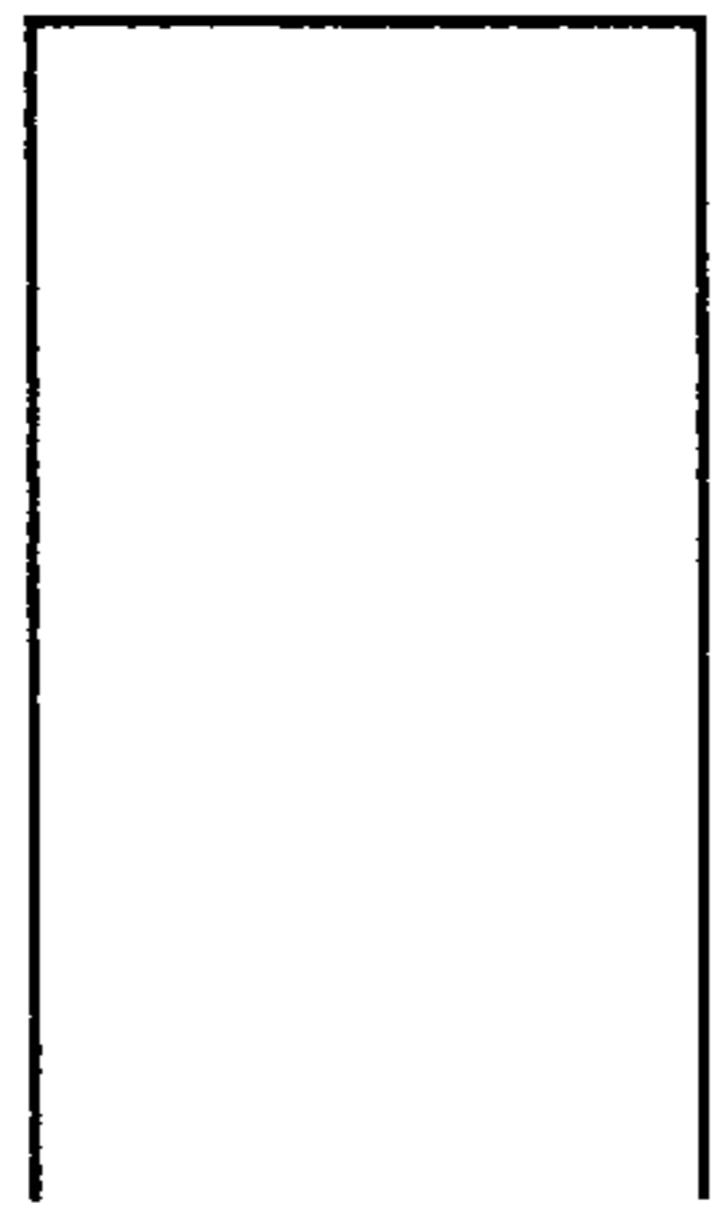

FIG. 9A

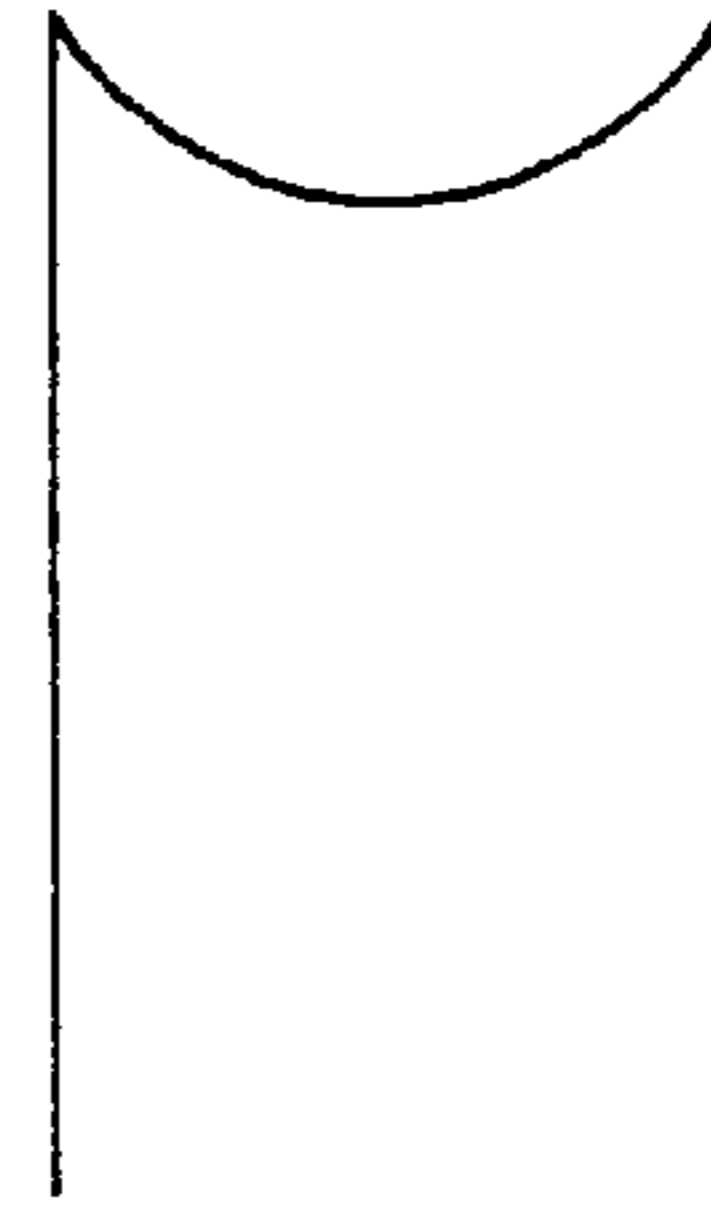

FIG. 9B

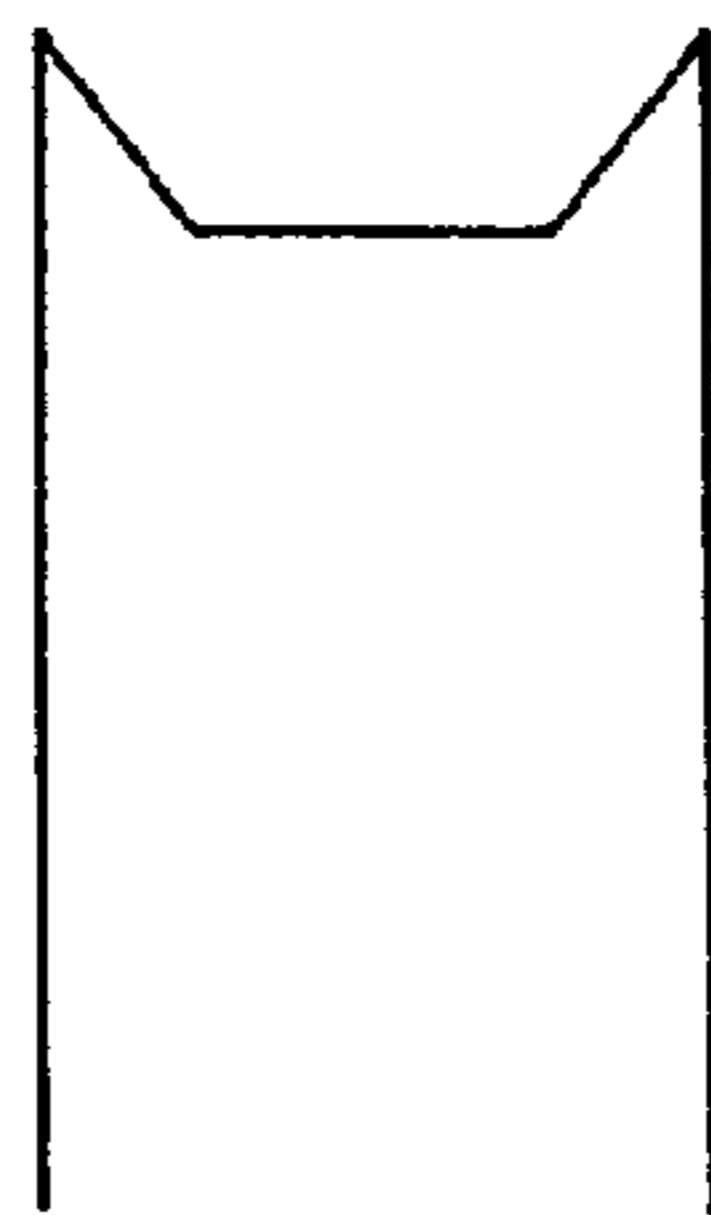

FIG. 9C

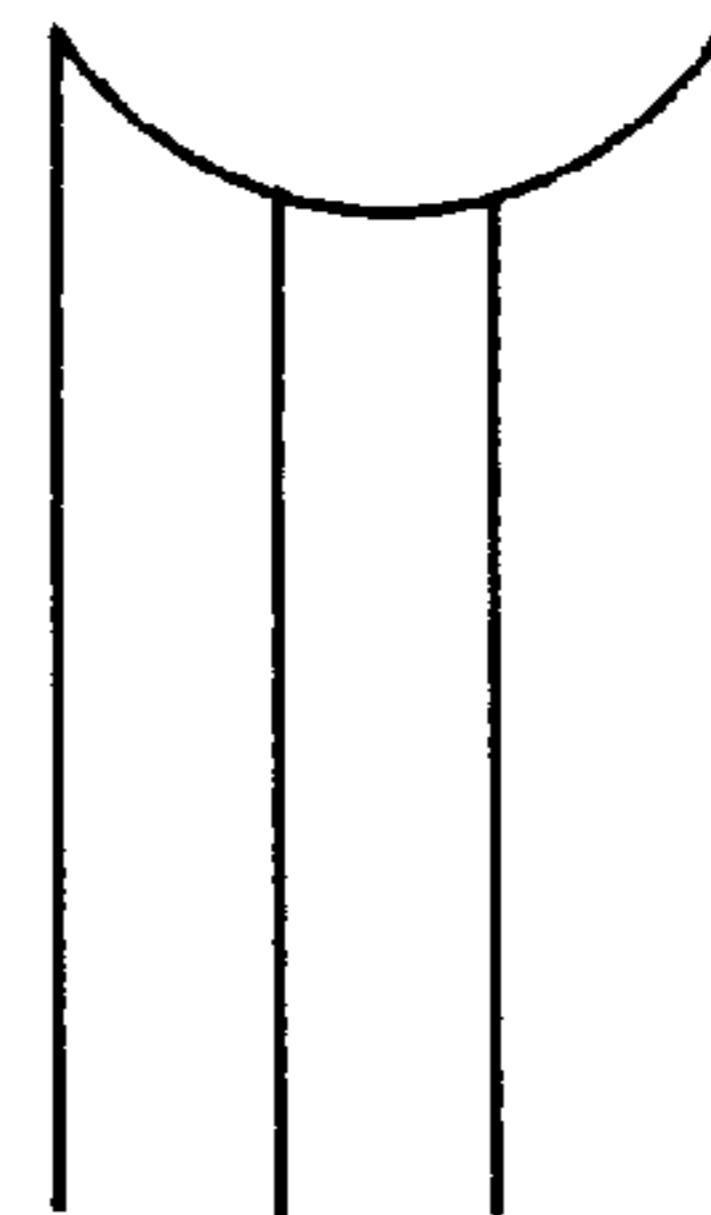

FIG. 9D

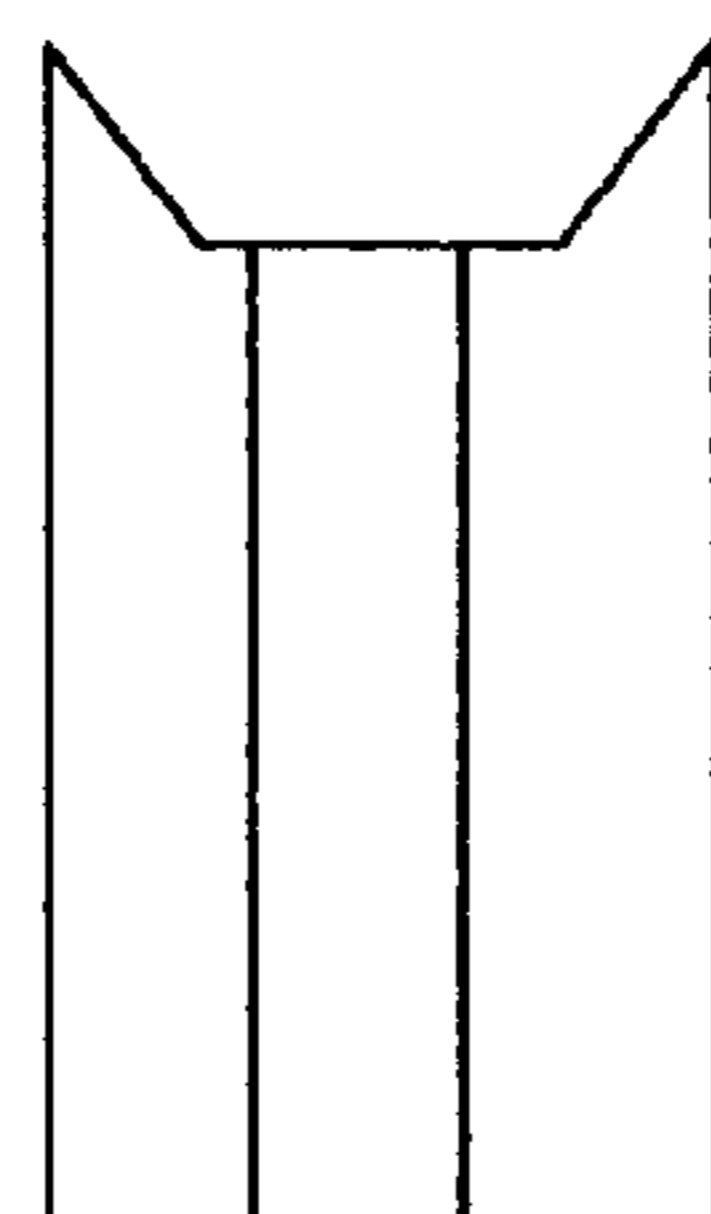

FIG. 9E

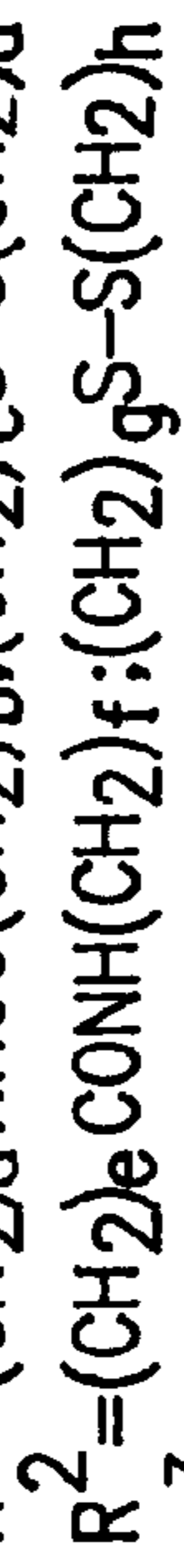
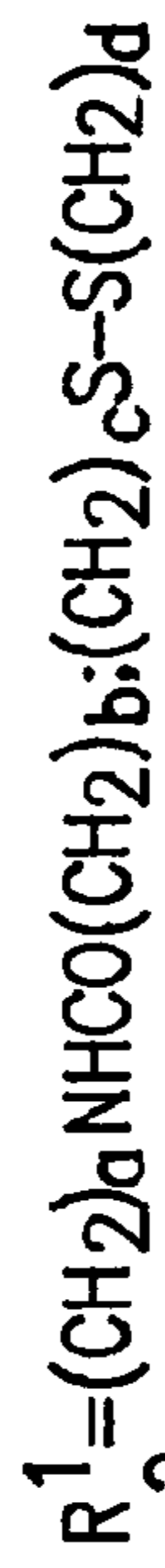
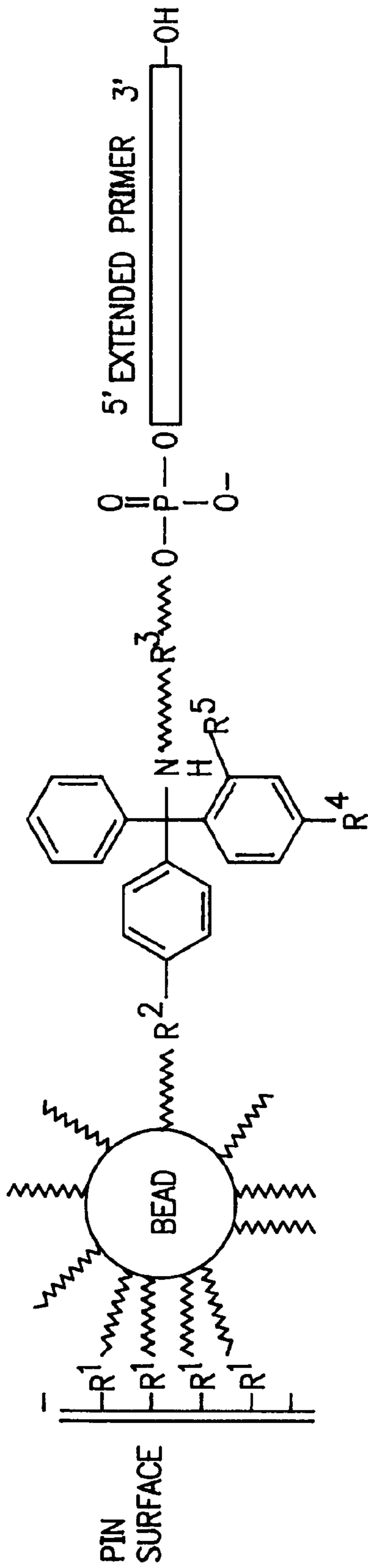

FIG. 10

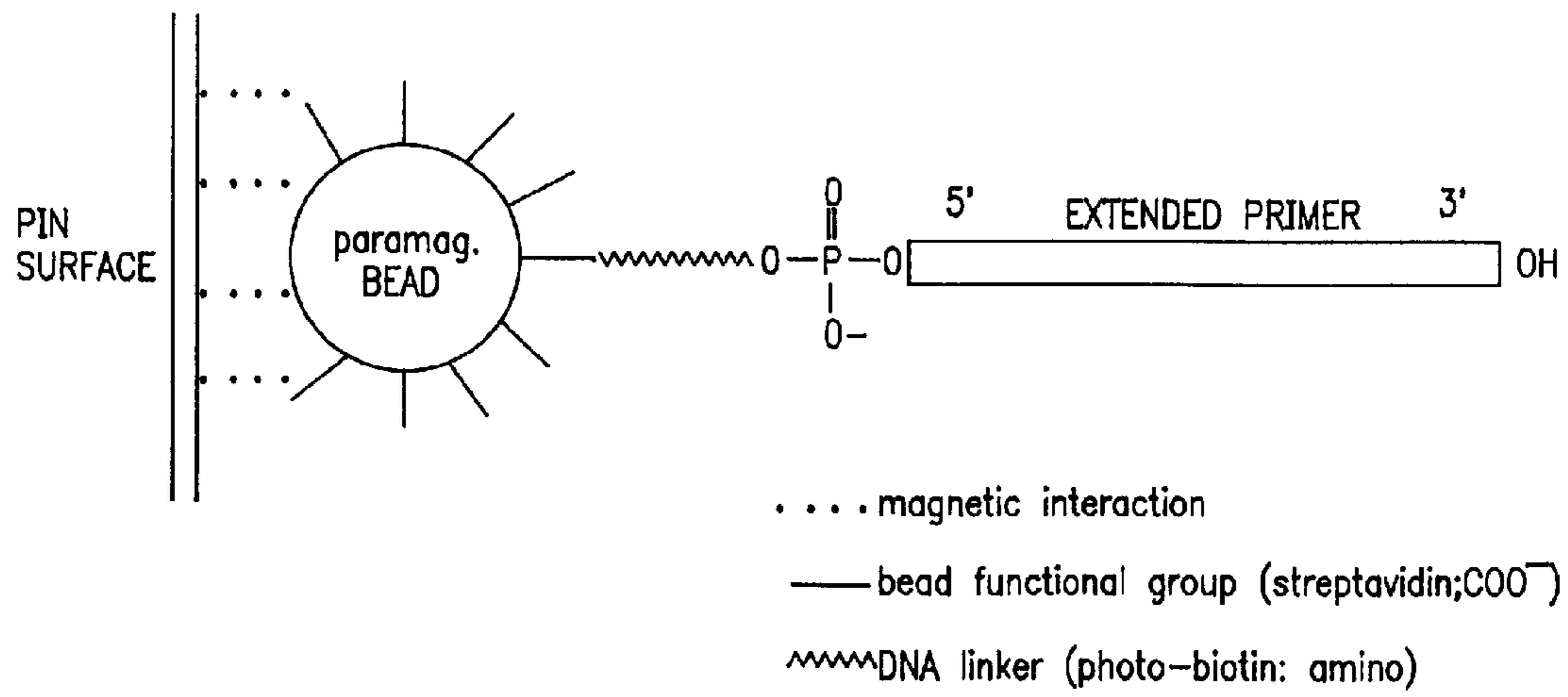

FIG. 11

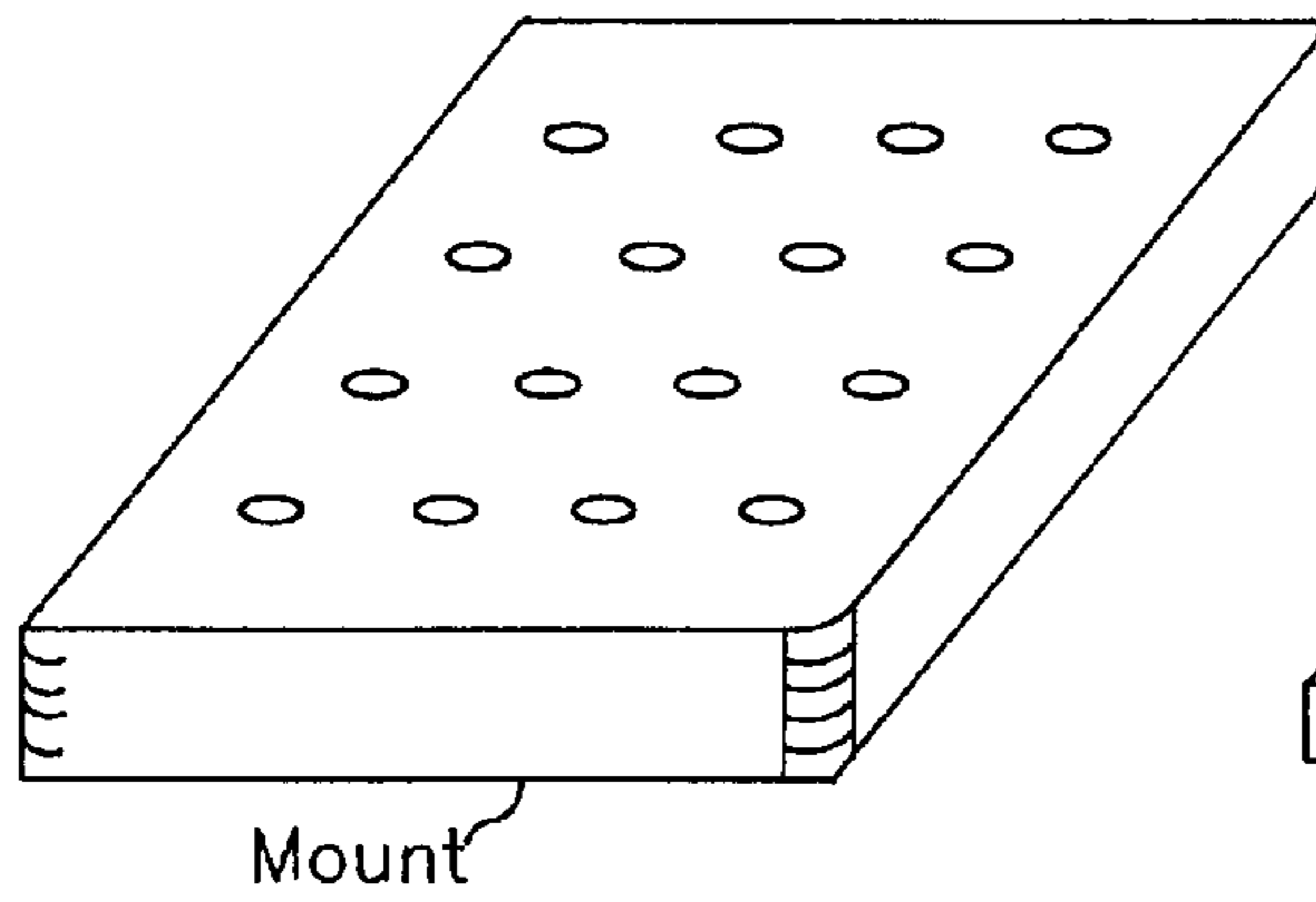

FIG. 12A

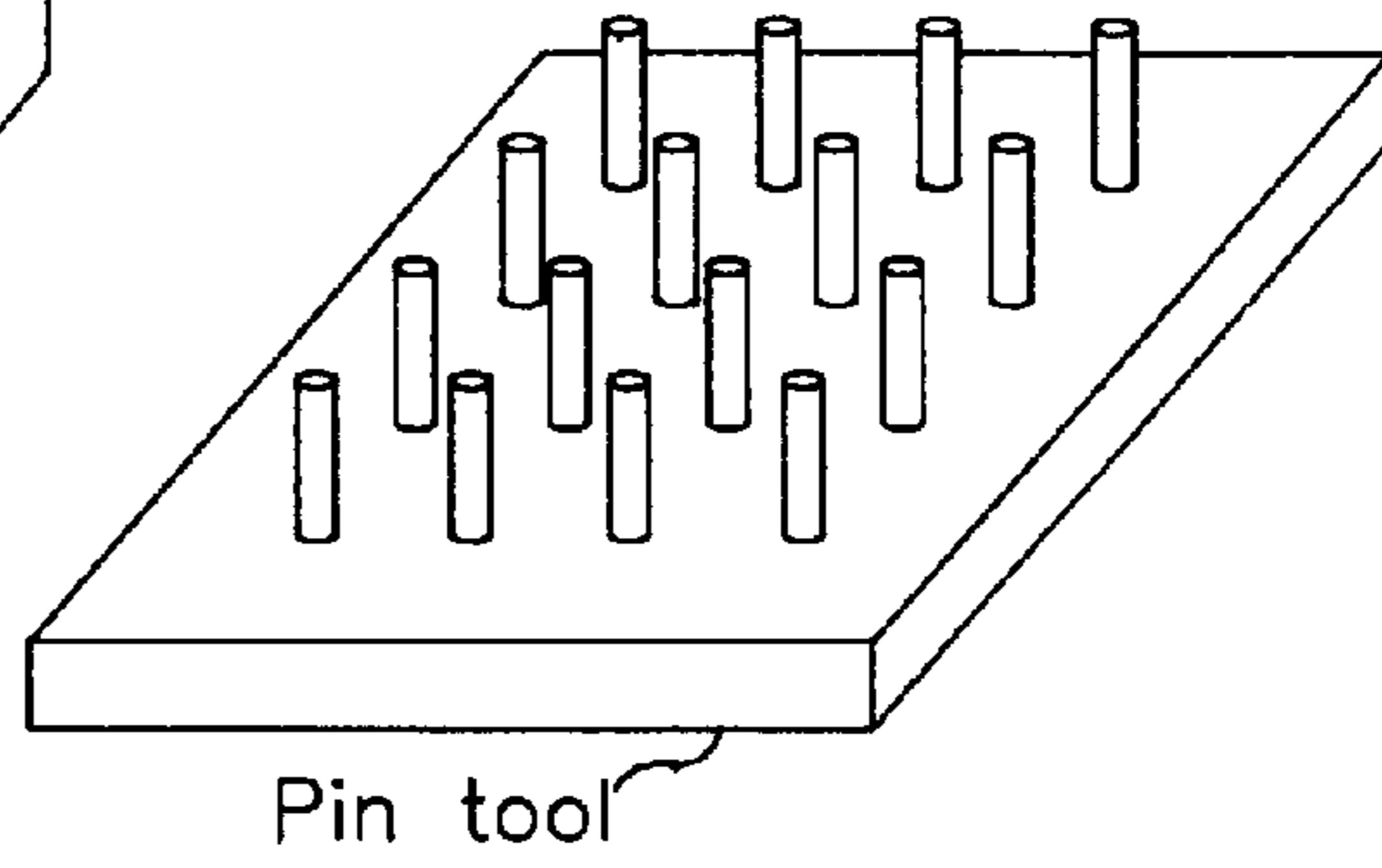

FIG. 12B

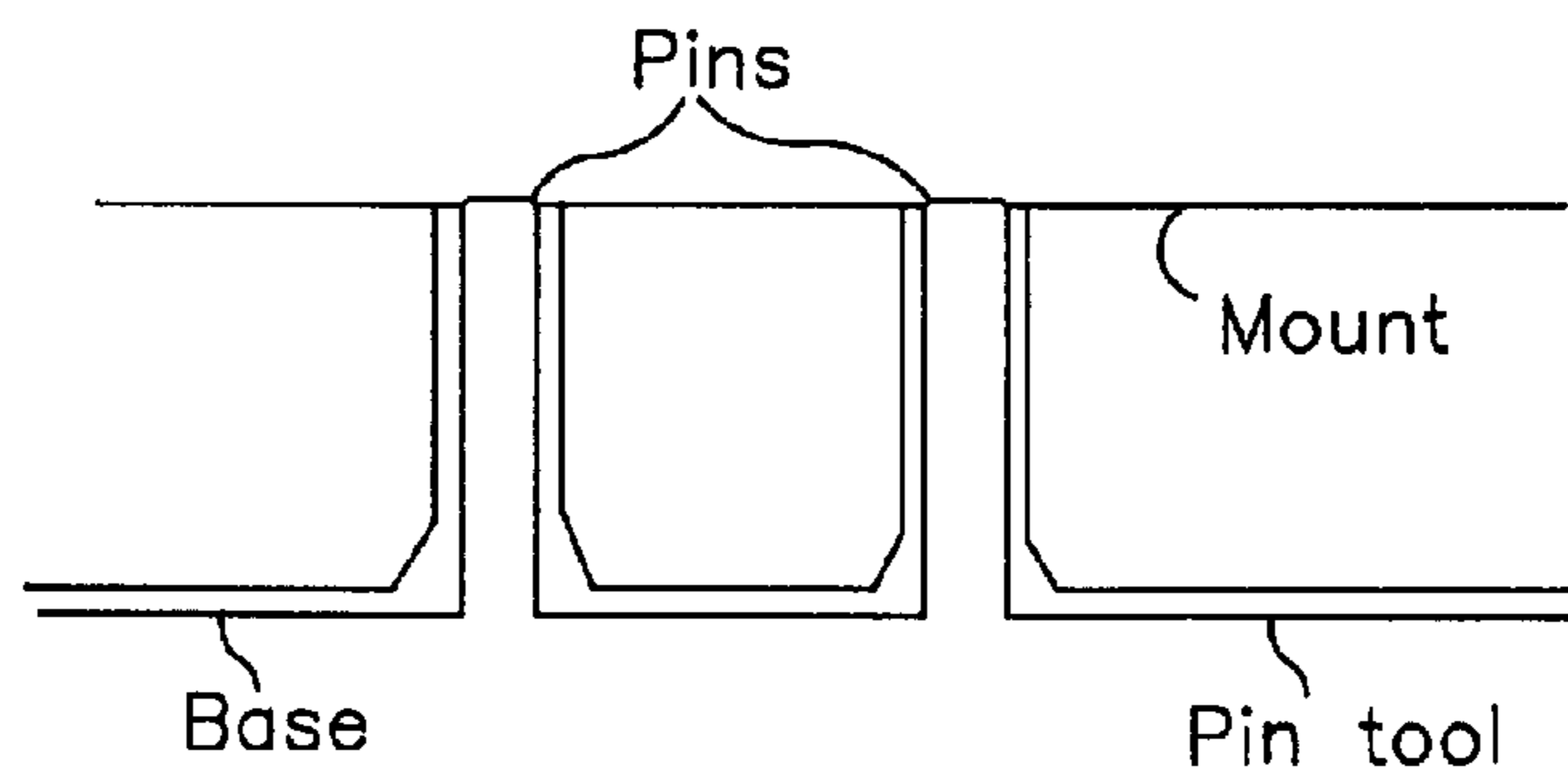

FIG. 12C

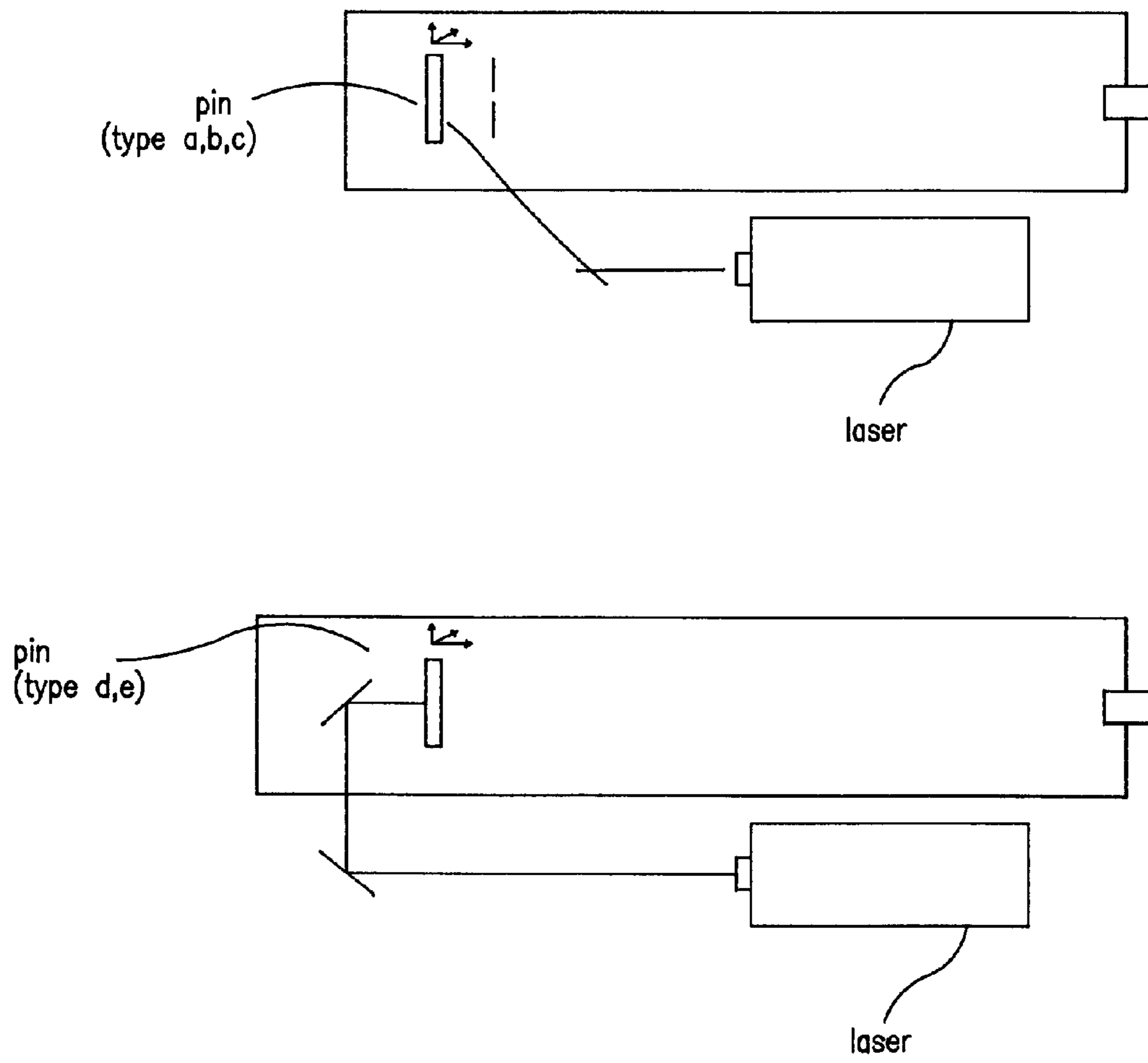

FIG. 13

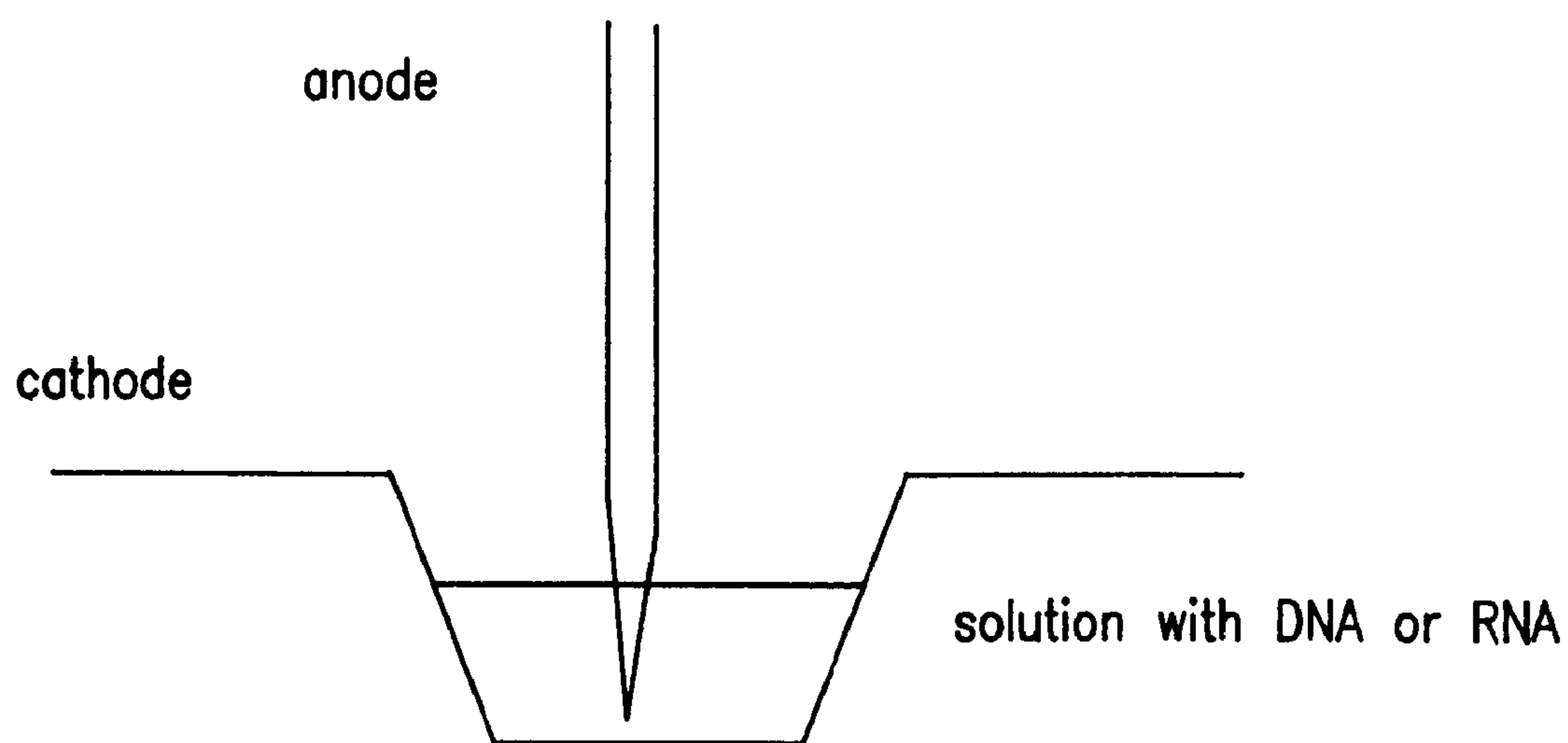
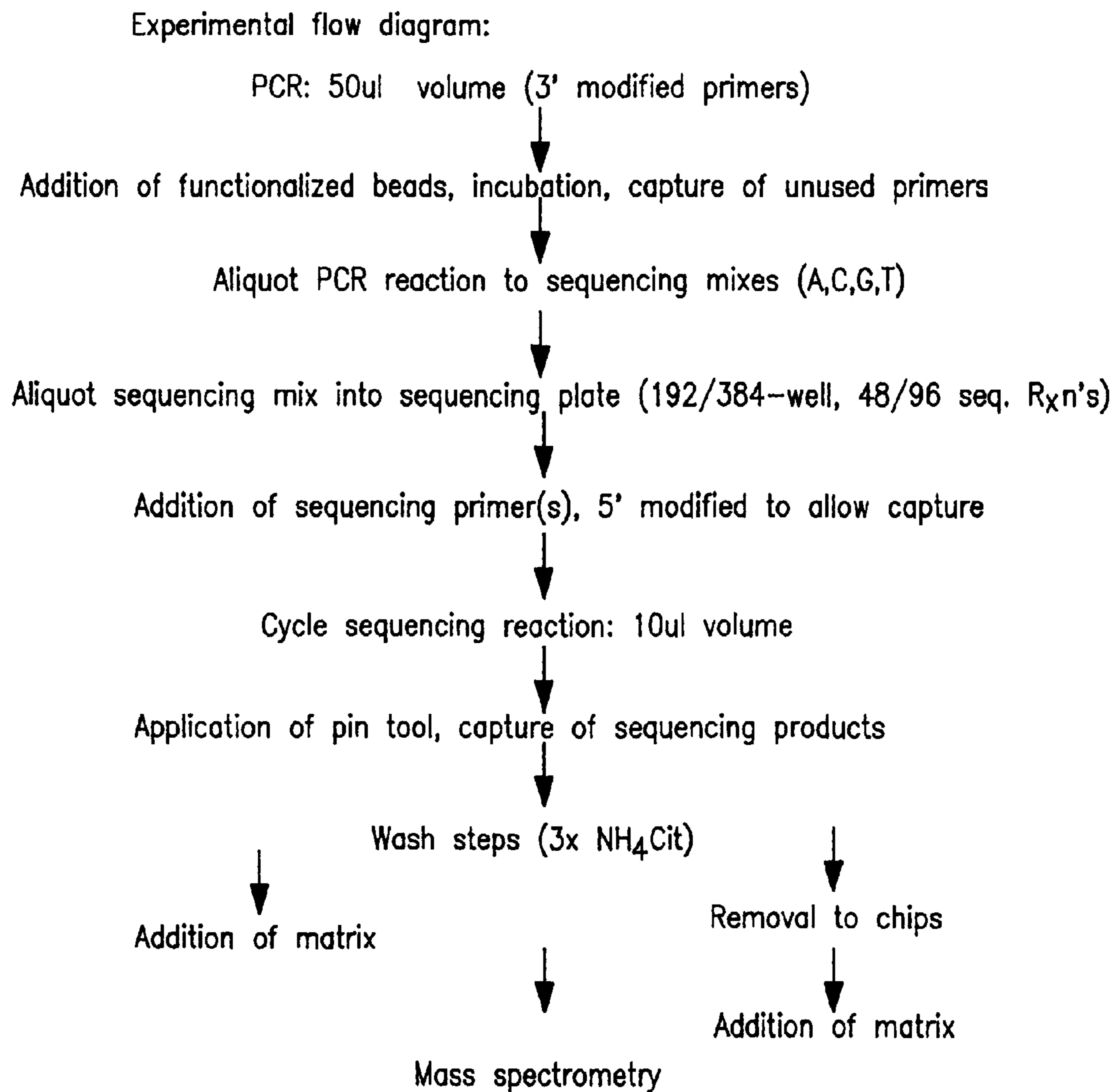

FIG. 14

**FIG. 15**

BEADS BOUND TO A SOLID SUPPORT AND TO NUCLEIC ACIDS

Matter enclosed in heavy brackets [] appears in the original patent but forms no part of this reissue specification; matter printed in italics indicates the additions made by reissue.

RELATED APPLICATIONS

Notice: More than one reissue application has been filed for the reissue of U.S. Pat. No. 6,133,436. The reissue applications are application Ser. No. 12/507,124 (the present application), and Ser. No. 10/277,021. The present application is a continuation reissue application of parent reissue application Ser. No. 10/277,021, filed Oct. 17, 2002, now U.S. Pat. No. RE41005.

This application is a continuation-in-part of U.S. Ser. No. 08/746,036 now U.S. Pat. No. 5,900,481 filed Nov. 6, 1996, entitled "Bead Linkers for Immobilizing Nucleic Acids to Solid Supports", [now U.S. Pat. No. 5,900,481,] the teachings of which are incorporated herein by reference.

BACKGROUND OF THE INVENTION

In the fields of molecular biology and biochemistry, as well as in the diagnosis of diseases, nucleic acid hybridization has become a powerful tool for the detection, isolation, and analysis of specific oligonucleotide sequences. Typically, such hybridization assays utilize an oligodeoxynucleotide probe that has been immobilized on a solid support; as for example in the reverse dot blot procedure (Saiki, R. K., Walsh, P. S., Levenson, C. H., and Erlich, H. A. (1989) Proc. Natl. Acad. Sci. USA 86, 6230). More recently, arrays of immobilized DNA probes attached to a solid surface have been developed for sequencing by hybridization (SBH) (Drmanac, R., Labat, I., Brukner, I., and Crkvenjakov, R. (1989) Genomics, 4, 114-128), (Strezoska, Z., Paunesku, T., Radosavljevic, D., Labat, I., Drmanac, R., and Crkvenjakov, R. (1991) Proc. Natl. Acad. Sci. USA, 88, 10089-10093). SBH uses an ordered array of immobilized oligodeoxynucleotides on a solid support. A sample of unknown DNA is applied to the array, and the hybridization pattern is observed and analyzed to produce many short bits of sequence information simultaneously. An enhanced version of SBH, termed positional SBH (PSBH), has been developed which uses duplex probes containing single-stranded 3'- or 5'-overhangs. (Broude, N. E., Sano, T., Smith, C. L., and Cantor, C. R. (1994) Proc. Natl. Acad. Sci. USA, 91, 3072-3076). It is now possible to combine a PSBH capture approach with conventional Sanger sequencing to produce sequencing ladders detectable, for example by gel electrophoresis (Fu, D., Broude, N. E., Köster, H., Smith, C. L., and Cantor, C. R. (1995) Proc. Natl. Acad. Sci. USA, 92, 10162-10166).

For the arrays utilized in these schemes, there are a number of criteria which must be met for successful performance. For example, the immobilized DNA must be stable and not desorb during hybridization, washing, or analysis. In addition, the density of the immobilized oligodeoxynucleotide must be sufficient for the ensuing analyses. However, there must be minimal non-specific binding of DNA to the surface. In addition, the immobilization process should not interfere with the ability of immobilized probes to hybridize. For the majority of applications, it is best for only one point of the DNA to be immobilized, ideally a terminus.

In recent years, a number of methods for the covalent immobilization of DNA to solid supports have been developed which attempt to meet all the criteria listed above. For example, appropriately modified DNA has been covalently attached to flat surfaces functionalized with amino acids, (Running, J. A., and Urdea, M. S. (1990) Biotechniques, 8, 276-277), (Newton, C. R., et al., (1993) Nucl. Acids Res., 21, 1155-1162.), (Nikiforov, T. T., and Rogers, Y. H. (1995) Anal Biochem., 227, 201-209) carboxyl groups, (Zhang, Y., et al., (1991) Nucl. Acids Res., 19, 3929-3933), epoxy groups (Lamtore, J. B., et al., (1994) Nucl. Acids Res. 22, 2121-2125), (Eggers, M. D., et al., (1994) BioTechniques, 17, 516-524) or amino groups (Rasmussen, S. R., et al., (1991) Anal. Biochem., 198, 138-142). Although many of these methods were quite successful for their respective applications, when used to link nucleic acids to two-dimensional (flat) supports, the density of the immobilized oligodeoxynucleotide is often insufficient for the ensuing analyses (Lamtore, J. B., et al., (1994) Nucl. Acids Res. 22, 2121-2125, Eggers, M. D., et al., (1994) BioTechniques, 17, 516-524).

SUMMARY OF THE INVENTION

In one aspect, the invention features novel compositions comprised of at least one bead conjugated to a solid support and further conjugated to at least one nucleic acid. The bead can be comprised of any of a variety of materials and may be swellable or nonswellable. Preferably the bead is made of a material selected from the group consisting of: silica gel, glass, magnet, Wang resin (4-(hydroxymethyl) phenoxymethylcopoly(styrene—1% divinylbenzene(DVB) resin), metal, plastic, cellulose, dextran cross-linked with epichlorohydrin (e.g., Sephadex^R), and agarose (e.g., Sepharose^R). In a preferred embodiment, the bead is of a size in the range of about 1 to about 100 μm in diameter. In another preferred embodiment, the solid support is selected from the group consisting of: a bead, capillary, plate, membrane, wafer, comb, pin, a wafer with pits, an array of pits or nanoliter wells.

In another aspect, the invention features preferred conjugation means for making the novel compositions. In a preferred embodiment, a covalent amide bond is formed between the bead and the insoluble support. In a particularly preferred embodiment, the covalent amide bond is formed by reacting a carboxyl-functionalized bead with an amino-functionalized solid support; or a carboxyl-functionalized support with an amino-functionalized bead.

In a further aspect, the invention features methods for isolating target nucleic acids from a sample or reaction mixture by a conjugation means described herein. In a particularly preferred method, the nucleic acids are directly analyzed by mass spectrometry.

In a final aspect, the invention features kits containing reagents for performing the conjugations and thereby immobilizing nucleic acids to an insoluble support via a bead linker.

As compared to "flat" surfaces, beads linked to a solid support provide an increased surface area for immobilization of nucleic acids. Furthermore, by selecting a bead with the desired functionality, a practitioner can select a functionalization chemistry for immobilizing nucleic acids, which is different from the chemistry of the solid support.

The above and further features and advantages of the instant invention will become clearer from the following Detailed Description and claims.

BRIEF DESCRIPTION OF THE DRAWINGS

FIG. 1 is a schematic showing the covalent attachment of a bead to a solid support and DNA to the bead.

3

FIG. 2 is a schematic showing the covalent attachment of Wang resin (4—(hydroxymethyl)phenoxyethylcopoly(styrene—1% divinylbenzene(DVB) resin)) beads to a solid support as described in Example 1.

FIG. 3 is a schematic representation of nucleic acid immobilization via covalent bifunctional trityl linkers as described in Example 2.

FIG. 4 is a schematic representation of nucleic acid immobilization via hydrophobic trityl linkers as described in Example 3.

FIG. 5 shows a MALDI-TOF mass spectrum of a supernatant of the matrix treated Dynabeads containing bound oligo (5' iminobiotin-TGCACCTGACTC, SEQ. ID. No. 1). An internal standard (CTGTGGTCGTGC, SEQ. ID. No. 2) was included in the matrix.

FIG. 6 shows a MALDI-TOF mass spectrum of a supernatant of biotin treated Dynabeads containing bound oligo (5' iminobiotin-TGCACCTGACTC, SEQ. ID. No. 1). An internal standard (CTGTGGTCGTGC, SEQ. ID. No. 2) was included in the matrix.

FIG. 7 schematically depicts conjugation of an unextended primer to a bead via reaction of a 2', 3'-diol on the primer with boronic acid functionalized beads.

FIG. 8 schematically depicts a pin tool apparatus.

FIG. 9 depicts various pin conformations. FIG. 9A shows a solid pin with a straight head. FIG. 9B shows a solid pin with a concave head. FIG. 9C shows a solid pin with a truncated pyramidal head. FIG. 9D shows a pin with a concave head and a hollowed center (through which can be inserted an optical fibre). FIG. 9E shows a pin with a truncated pyramidal head and a hollowed center.

FIG. 10 is a schematic representation of the conjugation of beads (activated carboxyl) to pins (amino-functionalized) via amide bonds, and attachment of DNA (via an acid-cleavable linker) to beads. A disulfide linker conjugating the beads to the pins and a thioether conjugation between the bead and the trityl group permits selective cleavage of the beads (with DNA still attached) from the pin surface.

FIG. 11 is a schematic representation of paramagnetic beads functionalized with streptavidin to pins via a magnetic interaction and attachment of DNA (via a linker (e.g. modified biotin or photocleavable biotin) to allow selective cleavage of the DNA from the beads.

FIGS. 12 A-C schematically represent a pintool apparatus and mount, each separately and a cross section of the mount and tool installed.

FIG. 13 is a schematic representation of mass spectrometry geometries for the pin conformations shown in FIGS. 9A-E.

FIG. 14 schematically depicts a pintool onto which a voltage is applied. When an electrical field is applied, nucleic acids are attracted to the anode. This system purifies nucleic acids, since uncharged molecules would remain in solution, while positively charged molecules are attracted towards the cathode.

FIG. 15 shows a flow chart of the steps involved in sequencing by mass spectrometry using post-biology capture.

DETAILED DESCRIPTION OF THE INVENTION

In general, the invention relates to use of functionalized beads for the immobilization of nucleic acids, wherein the beads are stably associated with a solid support.

FIG. 1 depicts a bead conjugated to a solid support through one or more covalent or non-covalent bonds. Nucleic acids can be immobilized on the functionalized bead before, during or after the bead is conjugated to the solid support. As used herein, the term "nucleic acid" refers to single stranded and/or

4

double stranded polynucleotides such as deoxyribonucleic acid (DNA), and ribonucleic acid (RNA) as well as analogs or derivatives of either RNA or DNA. Also included in the term "nucleic acid" are analogs of nucleic acids such as peptide nucleic acid (PNA), phosphorothioate DNA, and the like.

Preferred nucleic acids for use in the subject invention are derivatized to contain at least one reactive moiety. Preferably the reactive moiety is at the 3' or 5' end. Alternatively, a nucleic acid can be synthesized with a modified base. In addition, modification of the sugar moiety of a nucleotide at positions other than the 3' and 5' position is possible through conventional methods. Also, nucleic acid bases can be modified, e.g., by using N7- or N9-deazapurine nucleosides or by modification of C-5 of dT with a linker arm, e.g., as described in F. Eckstein, ed., "Oligonucleotides and Analogues: A Practical Approach," IRL Press (1991). Alternatively, backbone-modified nucleic acids (e.g., phosphoramidate DNA) can be used so that a reactive group can be attached to the nitrogen center provided by the modified phosphate backbone.

In preferred embodiments, modification of a nucleic acid, e.g., as described above, does not substantially impair the ability of the nucleic acid or nucleic acid sequence to hybridize to its complement. Thus, any modification should preferably avoid substantially modifying the functionalities of the nucleic acid which are responsible for Watson-Crick base pairing. The nucleic acid can be modified such that a non-terminal reactive group is present, and the nucleic acid, when immobilized to the support, is capable of self-complementary base pairing to form a "hairpin" structure having a duplex region.

Examples of insoluble supports for use in the instant invention include beads (silica gel, controlled pore glass, magnetic beads, biomagnetic separation beads such as Dynabeads^R, Wang resin; Merrifield resin, which is chloromethylated copolystyrene—divinylbenzene(DVB) resin, Sephadex^R/Sephacrose^R beads, cellulose beads, etc.), capillaries, flat supports such as glass fiber filters, glass surfaces, metal surfaces (steel, gold, silver, aluminum, silicon and copper), plastic materials including multiwell plates or membranes (e.g., of polyethylene, polypropylene, polyamide, polyvinylidenedifluoride), wafers, combs, pins or needles (e.g., arrays of pins suitable for combinatorial synthesis or analysis) or beads in an array of pits or nanoliter wells of flat surfaces such as wafers (e.g. silicon wafers), wafers with pits with or without filter bottoms.

An appropriate "bead" for use in the instant invention includes any three dimensional structure that can be conjugated to a solid support and provides an increased surface area for binding of DNA. Preferably the bead is of a size in the range of about 1 to about 100 μm in diameter. For use in the invention, a bead can be made of virtually any insoluble or solid material. For example, the bead can be comprised of silica gel, glass (e.g. controlled-pore glass (CPG)), nylon, Wang resin, Merrifield resin, Sephadex^R/Sephacrose^R, cellulose, magnetic beads, Dynabeads^R, a metal surface (e.g. steel, gold, silver, aluminum, silicon and copper), a plastic material (e.g., polyethylene, polypropylene, polyamide, polyester, polyvinylidenedifluoride (PVDF)) and the like. Beads can be swellable, e.g., polymeric beads such as Wang resin, or non-swallowable (e.g., CPG).

As used herein, the term "conjugated" refers to ionic or covalent attachment. Preferred conjugation means include: streptavidin- or avidin- to biotin interaction; hydrophobic interaction; magnetic interaction (e.g. using functionalized Dynabeads); polar interactions, such as "wetting" associations between two polar surfaces or between oligo/polyethylene glycol; formation of a covalent bond, such as an amide

5

bond, disulfide bond, thioether bond, or via crosslinking agents; and via an acid-labile linker. In a preferred embodiment for conjugating nucleic acids to beads, the conjugating means introduces a variable spacer between the beads and the nucleic acids. In another preferred embodiment, the conjugation is photocleavable (e.g. streptavidin- or avidin- to biotin interaction can be cleaved by a laser, for example for mass spectrometry).

Appropriate cross-linking agents for use in the invention include a variety of agents that are capable of reacting with a functional group present on a surface of the bead, insoluble support and or nucleic acid and with a functional group present in the nucleic acid and/or bead, respectively. Reagents capable of such reactivity include homo- and hetero-bifunctional reagents, many of which are known in the art. Hetero-bifunctional reagents are preferred. A preferred bifunctional cross-linking agent is N-succinimidyl(4-iodoacetyl) aminobenzoate (SIAB). However, other crosslinking agents, including, without limitation, dimaleimide, dithio-bis-nitrobenzoic acid (DTNB), N-succinimidyl-S-acetyl-thioacetate (SATA), N-succinimidyl-3-(2-pyridyldithio) propionate (SPDP), succinimidyl 4-(N-maleimidomethyl) cyclohexane-1-carboxylate (SMCC) and 6-hydrazinonicotinamide (HYNIC) may also be used in the novel process. In certain embodiments, the cross-linking agent can be selected to provide a selectively cleavable bond when the nucleic acid molecule is immobilized on the insoluble support. For example, a photolabile cross-linker such as 3-amino-(2-nitrophenyl)propionic acid (Brown et al. (1995) *Molecular Diversity* 4:12 and Rothschild et al (1996) *Nucleic Acids Res.* 24:351-66) can be employed to provide a means for cleaving the nucleic acid from the beads or insoluble (e.g., solid) support, if desired. For further examples of cross-linking reagents, see, e.g., S. S. Wong, "Chemistry of Protein Conjugation and Cross-Linking," CRC Press (1991), and G. T. Hermanson, "Bioconjugate Techniques," Academic Press (1995).

In one preferred embodiment, a covalent amide bond is formed between a bead and a insoluble support by reacting a carboxyl-functionalized bead with an amino-functionalized solid support (e.g., as described in Example 1, below, by reacting a carboxyl-functionalized Wang resin with an amino-functionalized silicon surface). Alternatively, a carboxyl-functionalized support can be reacted with an amino-functionalized bead, which take advantage of an acid-cleavable bifunctional trityl protection scheme employed for nucleic acid attachment. The bifunctional trityl linker can also be attached to the 4-nitrophenyl active ester on a resin (e.g. Wang resin) via an amino group as well as from a carboxy group via an amino resin.

In the bifunctional trityl approach, the beads may require treatment with a volatile acid (e.g. formic acid, trifluoroacetic acid, etc.) to ensure that the nucleic acid is cleaved and can be removed. In which case, the nucleic acid may be deposited as a beadless patch at the bottom of a well in the solid support or on the flat surface of the solid support. After addition of matrix solution, the nucleic acid can then be desorbed into the mass spectrometer, for example.

The hydrophobic trityl linkers can also be exploited as acid-labile linkers by using a volatile acid or an appropriate matrix solution (e.g. a matrix solution containing, for example, 3-hydroxypicolinic acid (3-HPA) to cleave the aminolink trityl group from the nucleic acid molecule). Also, the acid lability can be changed. For example, trityl, monomethoxy, dimethoxy- or trimethoxytrityl can be changed to the appropriate p-substituted and even more acid labile tritylamine derivatives of the nucleic acids (i.e. trityl

6

ether and tritylamine bonds to the nucleic acid can be made). Therefore, the nucleic acid may be removed from the hydrophobic linker, for example, by disrupting the hydrophobic attraction or by cleaving tritylether or tritylamine bonds under acidic or the usual mass spectrometry conditions (e.g. wherein the matrix, such as 3-HPA acts as an acid)

As pointed out above, the bead can also be associated with the solid support by non-covalent interactions. For example, a magnetic bead (e.g., a bead capable of being magnetized, e.g., a ferromagnetic bead) can be attracted to a magnetic solid support, and can be released from the support by removal of the magnetic field. Alternatively, the bead can be provided with an ionic or hydrophobic moiety, which can associate with, respectively, an ionic or hydrophobic moiety of the solid support. Also, a bead can be provided with a member of a specific binding pair, and become immobilized to a solid support provided with a complementary binding moiety. For example, a bead coated with avidin or streptavidin can be bound to a surface coated with biotin or derivatives of biotin such as imino-biotin. It will be appreciated that the binding members can be reversed, e.g., a biotin-coated bead can bind to a streptavidin-coated solid support. Other specific binding pairs contemplated for use in the invention include hormone-receptor, enzyme-substrate, nucleic acid-complementary nucleic acid, antibody-antigen and the like.

Examples of preferred binding pairs or linker/interactions are shown in the following Table 1

TABLE 1

LINKER/INTERACTION	EXAMPLES
streptavidin-biotin ^{a,c} /photolabile biotin ^b	biotinylated pin, avidin beads, photolabile biotin DNA
hydrophobic ^a	C18-coated pin, tritylated DNA
magnetic ^a	electromagnetic pin, streptavidin Dynabeads, biotin DNA
acid-labile linker ^b	glass pin, bifunctional trityl-linked DNA
amide bond(s) ^c	silicon wafer, Wang resin, amino-linked DNA
disulfide bond ^a	silicon wafer, beads are bound on the flat surface forming arrays or in arrays of nanoliter wells, thiol beads, thiolated DNA
photocleavable bond/linker thioether bond ^c	silicon wafer, beads are bound on the flat surface forming arrays or in arrays of nanoliter wells, thiolated DNA

^aThese interactions are reversible.

^bThese non-reversible interactions are rapidly cleaved.

^cUnless cleavable-linkers are incorporated at some point in the scheme, only the complement of the solid-bound DNA can be analysed in these schemes.

In a particularly preferred embodiment the bead is conjugated to the solid support and/or the nucleic acid is conjugated to the bead using an acid-labile bond. For example, use of a trityl linker, as further described in the following Examples 2 and 3, can provide a covalent or hydrophobic conjugation. Regardless of the nature of the conjugation, the trityl group is readily cleaved in acidic conditions.

A nucleic acid can be bound to a bead which is itself bound to a solid support, e.g., by any of the chemistries discussed above for the attachment of nucleic acids to solid supports, or attachment of beads to solid supports.

In certain embodiments, the invention contemplates the use of orthogonally-cleavable linkers for binding the bead to the solid support, and for binding the nucleic acid to the bead. Thus, a bead can be selectively cleaved from the surface without cleaving the nucleic acid from the bead, while the nucleic acid is cleaved from the bead at a later stage. For

example, a disulfide linker (which can be cleaved, using, e.g., DTT) could be employed to bind the bead to the solid surface, and a bead-nucleic acid linker involving an acid-cleavable bifunctional trityl group could be used to immobilize a nucleic acid to the bead. Alternatively the linkage of the nucleic acid could be cleaved while the linkage of the bead to the support remains intact.

A bead can be bound to a solid support through a linking group which can be selected to have a length and a chemical nature such that high-density binding of beads to the solid support, and/or high-density binding of nucleic acid to the beads, is promoted. Such a linking group would have a "tree-like" structure in providing a multiplicity of functional groups per attachment site on the solid support such as polylysine, polyglutamic acid, pentaerythrole and tris-hydroxy-aminomethane.

In certain embodiments, beads can be cross-linked to other beads, e.g., by use of homobifunctional crosslinking reagents. Cross-linked beads can provide additional mechanical strength compared to non-crosslinked beads.

The methods and compositions described herein, can be used to isolate (purify) target nucleic acids from biological samples (reactions). For example, the compositions and methods can be used to isolate particular nucleic acids, which are generated by cloning (Sambrook et al., *Molecular Cloning: A Laboratory Manual*, Cold Spring Harbor Laboratory Press, 1989), polymerase chain reaction (PCR) (C. R. Newton and A. Graham, PCR, BIOS Publishers, 1994), ligase chain reaction (LCR) (Wiedmann, M., et. al., (1994) PCR Methods Appl. Vol. 3, Pp. 57-64; F. Barany Proc. Natl. Acad. Sci USA 88, 189-93 (1991), strand displacement amplification (SDA) (G. Terrance Walker et al., *Nucleic Acids Res.* 22, 2670-77 (1994)) European Patent Publication Number 0 684 315 entitled "Strand Displacement Amplification Using Thermophilic Enzymes") and variations such as RT-PCR (Higuchi, et al., *Bio/Technology* 11:1026-1030 (1993)), allele-specific amplification (ASA), cycle sequencing and transcription based processes.

Further, the methods and compositions can be used to isolate or transfer particular nucleic acids during the performance of a particular reaction. For example, a PCR reaction can be performed to 'master' mix without addition of the dideoxynucleotides (d/ddNTPs) or sequencing primers. Aliquots can then be isolated via a conjugation means described herein and transferred, for example to a sequencing plate, where d/ddNTPs and primers can then be added to perform a sequencing reaction. Alternatively, the PCR can be split between A, C, G, and T master mixes. Aliquots can then be transferred to a sequencing plate and sequencing primers added.

For example, 0.4-0.5 pmol of PCR product can be used in a cycle-sequencing reaction using standard conditions, allowing each PCR to be used for 10 sequencing reactions (10x A, C, G, and T). The sequencing reactions can be carried out in a volume of 10 μ l containing 5-6 pmol of 5'-labeled sequencing primer in a standard 384 microwell plate allowing up to 96 sequencing reactions (3360 bases at 35 bases per reaction). Alternatively, a 192 microwell plate approximately 5x5 cm in a 12x16 format can be used. This format allows up to 48 sequencing reactions to be carried out per well, resulting in 1680 bases per plate (at 35 bases per reaction). The format of the sequencing plate will determine the dimensions of the transfer agent (e.g. pin-tool).

A pin tool in a 4x4 array (FIG. 8) can be applied to the wells of the sequencing plate and the sequencing products captured on functionalized beads as described herein, which are attached to the tips of the pins (≥ 1 pmol capacity). During

the capture/incubation step, the pins can be kept in motion (vertical, 1-2 mm travel) to mix the sequencing reaction and increase the efficiency of the capture.

Alternatively, the nucleic acid can be directly captured onto the pin-tool, for example, a linking functionality on the pin-tool can immobilize the nucleic acid upon contact. Further, immobilization can result from application to the pin-tool of an electrical field, as shown in FIG. 14. When a voltage is applied to the pin-tool, the nucleic acids are attracted to the anode. This system also purifies nucleic acids, since uncharged molecules remain in solution and positively charged molecules are attracted to the cathode. For more specificity, the pin-tool (with or without voltage), can be modified to contain a partially or fully single stranded oligonucleotide (e.g. about 5-12 base pairs). Only complementary nucleic acid sequences (e.g. in solution) are then specifically conjugated to the pins.

In yet a further embodiment, a PCR primer can be conjugated to the tip of a pin-tool. PCR can be performed with the solid phase (pin-tool)-bound primer and a primer in solution, so that the PCR product becomes attached to the pin-tool. The pin-tool with the amplification product can then be removed from the reaction and analyzed (e.g. by mass spectrometry).

Examples of different pin conformations are shown in FIG. 9. For example, FIGS. 9a, 9b. and 9c. show a solid pin configuration. FIGS. 9d. and 9e show pins with a channel or hole through the center, for example to accommodate an optic fibre for mass spectrometer detection. The pin can have a flat tip or any of a number of configurations, including nanowell, concave, convex, truncated conic or truncated pyramidal (e.g. size 4-800 μ across x100 μ depth). In a preferred embodiment, the individual pins are about 5 mm in length and about 1 mm in diameter. The pins and mounting plate can be made of polystyrene (e.g. one-piece injection moulded). Polystyrene is an ideal material to be functionalised and can be moulded with very high tolerances. The pins in a pin-tool apparatus may be collapsible (eg, controlled by a scissor-like mechanism), so that pins may be brought into closer proximity, reducing the overall size.

Captured nucleic acids can be analyzed by any of a variety of means including, for example, spectrometric techniques such as UV/VIS, IR, fluorescence, chemiluminescence, or NMR spectroscopy, mass spectrometry, or other methods known in the art, or combinations thereof. Preferred mass spectrometer formats include ionization (I) techniques, such as matrix assisted laser desorption (MALDI), continuous or pulsed electrospray (ESI) and related methods (e.g. Ionspray or Thermospray), or massive cluster impact (MCI); these ion sources can be matched with detection formats including linear or non-linear reflectron time-of-flight (TOF), single or multiple quadrupole, single or multiple magnetic sector, Fourier Transform ion cyclotron resonance (FTICR), ion trap, and combinations thereof (e.g., ion-trap/time-of-flight). For ionization, numerous matrix/wavelength combinations (MALDI) or solvent combinations (ESI) can be employed.

If conditions preclude direct analysis of captured DNA, then the DNA can be released and/or transferred. However, it may be important that the advantages of sample concentration are not lost at this stage. Ideally, the sample should be removed from the surface in as little a volume of eluent as possible, and without any loss of sample. Another alternative is to remove the beads (+sample) from the surface, where relevant, and measure the sample directly from the beads.

For example, for detection by mass spectrometry, the pin-tool can be withdrawn and washed several times, for example in ammonium citrate to condition the sample before addition of matrix. For example, the pins can simply be dipped into

matrix solution. The concentration of matrix can then be adjusted such that matrix solution only adheres to the very tip of the pin. Alternatively, the pintoole can be inverted and the matrix solution sprayed onto the tip of each pin by a micro-drop device. Further, the products can be cleaved from the pins, for example into a nanowell on a chip, prior to addition of matrix.

For analysis directly from the pins, a stainless steel 'mask' probe can be fitted over the pins in one scheme (FIG. 12) which can then be installed in the mass spectrometer.

Two mass spectrometer geometries for accommodating the pin-tool apparatus are proposed in FIG. 13. The first accommodates solid pins. In effect, the laser ablates a layer of material from the surface of the crystals, the resultant ions being accelerated and focused through the ion optics. The second geometry accommodates fibre optic pins in which the samples are lasered from behind. In effect, the laser is focused onto the pin-tool back plate and into a short optical fibre (about 100 μm in diameter and about 7 mm length to include thickness of the back plate). This geometry requires the volatilised sample to go through the depth of the matrix/bead mix, slowing and cooling down the ions resulting in a type of delayed extraction which should actually increase the resolution of the analysis.

The probe through which the pins are fitted can also be of various geometries. For example, a large probe with multiple holes, one for each pin, fitted over the pin-tool. The entire assembly is translated in the X-Y axes in the mass spectrometer. Alternatively, as a fixed probe with a single hole, which is large enough to give an adequate electric field, but small enough to fit between the pins. The pin-tool is then translated in all three axes with each pin being introduced through the hole for sequential analyses. This format is more suitable for the larger pin-tool (i.e. based on a standard 384 well microplate format). The two probes described above, are both suitable for the two mass spectrometer geometries described above.

FIG. 15 schematically depicts the steps involved in mass spectrometry sequencing by post biology capture as described above.

The methods of the invention are useful for providing spatially-addressable arrays of nucleic acids immobilized on beads, which are further attached to solid supports. Such spatially addressable or pre-addressable arrays are useful in a variety of processes (e.g., SBH, quality control, and DNA sequencing diagnostics). In another aspect, the invention provides combinatorial libraries of immobilized nucleic acids bound to beads, which are further bound to a solid support as described above.

In still another aspect, the invention provides a kit for immobilizing nucleic acids on beads, which are further bound to a solid support. In one embodiment, the kit comprises an appropriate amount of: i) beads, and/or ii) the insoluble support, and iii) conjugation means. The kits described herein can also optionally include appropriate buffers; containers for holding the reagents; and/or instructions for use.

The present invention is further illustrated by the following Examples, which are intended merely to further illustrate and should not be construed as limiting. The entire contents of all of the references (including literature references, issued patents, published patent applications, and co-pending patent applications) cited throughout this application are hereby expressly incorporated by reference.

EXAMPLE 1

Attachment of Resin Beads to a Silicon Surface

A silicon surface (e.g. of a silicon wafer) is derivatized with amino groups by treatment with 3-aminopropyltriethoxysi-

lane. Wang resin beads are treated with succinic anhydride to provide carboxyl-functionalized resin beads. The carboxyl-functionalized resin beads are then coupled to the amino-functionalized silicon surface with a coupling reagent (for example, dicyclohexylcarbodiimide (DCC)), in the presence of p-nitrophenol. The resin beads become covalently linked to the silicon surface, and the unreacted carboxyl groups of the resin are converted to the p-nitrophenyl ester (an activated ester suitable for coupling with a nucleic acid).

Alternatively, the carboxyl groups of the Wang resin are transformed to the p-nitrophenyl active esters prior to reacting with the amino-functionalized silicon surface.

Thus, resin beads can be rapidly and conveniently attached to a silicon surface, and can be simultaneously converted to a reactive form suitable for covalent attachment of nucleic acids.

EXAMPLE 2

Immobilization of Nucleic Acids on Solid Supports via an Acid-labile Covalent Bifunctional Trityl Linker

Aminolink DNA was prepared and purified according to standard methods. A portion (10 eq) was evaporated to dryness on a speedvac and suspended in anhydrous DMF/pyridine (9:1; 0.1 ml). To this was added the chlorotryl chloride resin (1 eq, 1.05 mol/mg loading) and the mixture was shaken for 24 hours. The loading was checked by taking a sample of the resin, detritylating this using 80% AcOH, and measuring the absorbance at 260nm. Loading was ca. 150 pmol/mg resin.

In 80% acetic acid, the half-life of cleavage was found to be substantially less than 5 minutes—this compares with trityl ether-based approaches of half-lives of 105 and 39 minutes for para and meta substituted bifunctional dimethoxytrityl linkers respectively. Preliminary results have also indicated that the 3-hydroxy picolinic acid matrix alone is sufficient to cleave the DNA from the chlorotryl resin during MALDI mass spectrometry.

EXAMPLE 3

Immobilization of Nucleic Acids on Solid Supports via Hydrophobic Trityl Linker

The primer contained a 5'-dimethoxytrityl group attached using routine trityl-on DNA synthesis.

C18 beads from an oligo purification cartridge (0.2 mg) placed in a filter tip was washed with acetonitrile, then the solution of DNA (50 ng in 25 l) was flushed through. This was then washed with 5% acetonitrile in ammonium citrate buffer (70 mM, 250 l). To remove the DNA from the C18, the beads were washed with 40% acetonitrile in water (10 l) and concentrated to ca 2 l on the Speedvac or directly subjected to MALDI mass spectrometry.

Alternatively C18 beads were first covalently attached to a silicon surface (e.g. a silicon wafer) or adsorbed to a flat surface by hydrophobic interaction.

The results showed that acetonitrile/water at levels of ca. >30% are enough to dissociate the hydrophobic interaction. Since the matrix used in MALDI contains 50% acetonitrile, the DNA can be released from the support and MALDIed successfully (with the trityl group removed during the MALDI process).

11

EXAMPLE 4

Attaching Beads to Silicon Chips

Amino derivatisation of silicon surface

The silicon wafers were washed with ethanol to remove surface debris and flamed over a bunsen burner until "red hot" to ensure oxidation of the surface. After cooling, the wafers were immersed in an anhydrous solution of 3-aminopropyltriethoxysilane in toluene (25%v/v) for 3 hours. The wafers were then washed with toluene (three times) then anhydrous dimethylacetamide (three times).

Activation of Wang resin beads

Vacuum-dried Wang resin beads (5g, 0.84mmol/g loading, 4.2 mmol, diameter 100-200 mesh), obtained from Novabiochem, were suspended in pyridine (40 ml) with DMAP (0.1 eq, 0.42 mmol, 51 mg). To this was added succinic anhydride (5 eq, 21 mmol, 2.10 g) and the reaction was shaken for 12 hours at room temperature. After this time, the beads were washed with dimethylformamide (three times), then pyridine (three times) and suspended in pyridine/dimethylformamide (1:1, 20 ml). 4-Nitrophenol (2 eq, 8.4 mmol, 1.40 g) was added and the condensation was activated by adding dicyclohexylcarbodiimide (DCC) (2 eq, 8.4 mmol, 1.73 g) and the reaction mixture was shaken for 12 hours. The beads were then washed with dimethylformamide, pyridine and hexane, and stored at 4 C.

Coupling of Beads to Silicon Wafers

The amino-derivatised silicon wafer is treated with a suspension of the 4-nitrophenol beads in dimethyl acetamide (DMA), and within five minutes, the beads are covalently linked to the surface. The coated surface can then be washed with DMA, ethanol and water, under which conditions the beads remain as a uniform monolayer. Care must be taken to avoid scratching the beaded surface. The beads can then be reacted with the amino-functionalised modified DNA.

EXAMPLE 5

Immobilization of Nucleic Acids on Solid Supports via Streptavidin-Iminobiotin

2-iminobiotin N-hydroxy-succinimid ester (Sigma) was conjugated to the oligonucleotides with a 3'- or 5'-amino linker following the conditions suggested by the manufacture. The completion of the reaction was confirmed by MALDI-TOF MS analysis and the product was purified by reverse phase HPLC.

For each reaction, 0.1 mg of streptavidin-coated magnetic beads (Dynabeads M-280 Streptavidin from Dynal) were incubated with 80 pmol of the corresponding oligo in the presence of 1M NaCl and 50 mM ammonium carbonate (pH 9.5) at room temperature for one hour. The beads with bound oligonucleotides were washed twice with 50 mM ammonium carbonate (pH 9.5). Then the beads were incubated in 2 µl of 3-HPA matrix at room temperature for 2 min. An aliquot of 0.5 µl of supernatant was applied to MALDI-TOF. For biotin displacement experiment, 1.6 nmol of free biotin (80 fold excess to the bound oligo) in 1 µl of 50 mM ammonium citrate was added to the beads. After a 5 min. incubation at room temperature, 1 µl of 3-HPA matrix was added and 0.5 µl of supernatant was applied to MALDI-TOF MS. To maximize the recovery of the bound iminobiotin oligo, the beads from the above treatment were again incubated with 2 µl of 3-HPA matrix and 0.5 µl of the supernatant was applied to MALDI-TOF MS.

12

Both matrix alone and free biotin treatment quantitatively released iminobiotin oligo off the streptavidin beads as shown in FIGS. 5 and 6. Almost no bound oligo was observed after the second treatment which confirmed the complete recovery

5 Equivalents

Those skilled in the art will recognize, or be able to ascertain using no more than routine experimentation, numerous equivalents to the specific procedures described herein. Such equivalents are considered to be within the scope of this invention and are covered by the following claims.

We claim:

1. A composition, comprising a bead conjugated to a solid copper support by covalent attachment and further conjugated to a nucleic acid, wherein the solid support is selected from the group consisting of multiwell plates, arrays of pits and multiwell supports comprising nanoliter wells] wherein the bead is bound to the solid support and the nucleic acid is bound to the bead using orthogonally cleavable linkers.

2. A composition of claim 1, wherein the bead is made from a material selected from the group consisting of: silica gel, glass, magnet, 4-(hydroxymethyl)phenoxyethylcopoly (styrene—1% divinylbenzene) resin, chloromethylated copolystyrene—divinylbenzene resin, metal, plastic, cellulose, dextran cross-linked with epichlorohydrin, and agarose.

3. A composition of claim 1, wherein the bead is swellable.

4. A composition of claim 1, wherein the bead is non-swellable.

5. A composition of claim 1, wherein the bead is in the range of 1 to 100 µm in diameter.

6. A composition of claim 1, wherein the nucleic acid is DNA.

7. A composition of claim 1, wherein the nucleic acid is RNA.

8. A process of making a bead conjugated to a solid support and further conjugated to a nucleic acid, comprising the steps of conjugating a bead to a nucleic acid; and conjugating a bead to a solid support, wherein the solid support is selected from the group consisting of multiwell plates, arrays of pits, and multiwell supports comprising nanoliter wells.]

9. A process of claim 8, wherein the bead is functionalized.]

10. A process of claim 9, wherein the bead is functionalized with carboxy functional groups.]

11. A process of claim 9, wherein the bead is functionalized with amino functional groups.]

12. A process of claim 9, wherein the bead is conjugated to the nucleic acid prior to conjugation of the bead to the solid support.]

13. A process of claim 9, wherein the bead is conjugated to the nucleic acid after the bead is conjugated to the solid support.]

14. A kit, comprising:

i) beads,

ii) an insoluble support, and

iii) conjugation means for linking nucleic acids to the beads and the beads to the support.]

15. The kit of claim 14, wherein the solid support is selected from the group consisting of: beads, capillaries, plates, membranes, wafers, combs, pins, wafers with arrays of pits, and supports with nanoliter wells.]

16. The kit of claim 14, wherein the bead is made from material selected from the group consisting of silica gel, glass, magnet, p-benzyloxybenzyl alcohol copolystyrene-divinyl benzene (DVB) resin, chlorotriethylchloride copolystyrene-DVB resin, chloromethylated copolystyrene-DVB resin, metal, plastic, cellulose, cross-linked dextran, and agarose gel.]

[17. A composition, comprising a bead conjugated to a solid support and further conjugated to a nucleic acid, wherein conjugation is effected with a crosslinking agent.]

[18. The method of claim 8, wherein conjugation is effected with a crosslinking agent.]

5

[19. A composition, comprising a bead conjugated to a solid support and further conjugated to a nucleic acid molecule comprising protein nucleic acid.]

[20. A composition, comprising a bead conjugated to a solid support and further conjugated to a nucleic acid, wherein conjugation is effected through a photocleavable linkage.]

10

[21. The composition of claim 20, wherein the linkage is cleaved by exposure to a laser.]

[22. The composition of claim 20, wherein the linkage is cleaved by exposure to electromagnetic radiation selected from ultraviolet, visible, infrared radiation or electromagnetic radiation generated by fluorescence or chemiluminescence, or combinations thereof.]

15

[23. A composition, comprising a bead conjugated to a solid support and further conjugated to a nucleic acid, wherein conjugation is effected through ionic linkages.]

20

24. The composition of claim 1, wherein the conjugation of the bead to the nucleic acid comprises a spacer.

25. The composition of claim 1, wherein the conjugation of the bead to the nucleic acid comprises streptavidin-biotin DNA.

25

26. The composition of claim 1, wherein the bead can be selectively cleaved from the solid surface without cleaving the nucleic acid from the bead.

30

27. The composition of claim 1, wherein the conjugation of the bead to the solid surface comprises a disulfide linker.

* * * * *