

US00RE44657E

(19) **United States**
(12) **Reissued Patent**
Miyake et al.

(10) **Patent Number:** **US RE44,657 E**
(45) **Date of Reissued Patent:** **Dec. 24, 2013**

(54) **SEMICONDUCTOR DEVICE**

438/30, 104, 158, 149, 151, 482, 710,
438/778; 345/204, 102, 211, 212

(75) Inventors: **Hiroyuki Miyake**, Kanagawa (JP);
Yutaka Shionoiri, Kanagawa (JP)

See application file for complete search history.

(73) Assignee: **Semiconductor Energy Laboratory**
Co., Ltd., Atsugi-shi, Kanagawa-ken
(JP)

(56) **References Cited**

U.S. PATENT DOCUMENTS

3,506,851 A 4/1970 Polkinghorn et al.
3,774,055 A 11/1973 Bapat

(Continued)

(21) Appl. No.: **13/471,870**

(22) Filed: **May 15, 2012**

FOREIGN PATENT DOCUMENTS

Related U.S. Patent Documents

Reissue of:

(64) Patent No.: **7,362,139**
Issued: **Apr. 22, 2008**
Appl. No.: **11/463,356**
Filed: **Aug. 9, 2006**

EP 0 055 136 6/1982
EP 0055136 A2 6/1982

(Continued)

U.S. Applications:

(60) Division of application No. 12/369,914, filed on Feb. 12, 2009, now Pat. No. Re. 43,401, which is a continuation of application No. 10/901,127, filed on Jul. 29, 2004, now Pat. No. 7,091,749, which is a continuation of application No. 10/202,861, filed on Jul. 26, 2002, now Pat. No. 6,788,108.

OTHER PUBLICATIONS

Foreign Communication in Singapore Application No. 200202969-2 dated Jun. 25, 2004 along with Australian Search Report dated Apr. 27, 2004 (8 pages).

(Continued)

(30) **Foreign Application Priority Data**

Jul. 30, 2001 (JP) 2001-229054

Primary Examiner — Vibol Tan

(74) *Attorney, Agent, or Firm* — Fish & Richardson P.C.

(51) **Int. Cl.**
G06F 3/038 (2013.01)
H01L 21/00 (2006.01)

(57) **ABSTRACT**

A circuit with a large load driving capability, which is structured by single polarity TFTs, is provided. With a capacitor (154) formed between a gate electrode and an output electrode of a TFT (152), the electric potential of the gate electrode of the TFT (152) is increased by a boot strap and normal output with respect to an input signal is obtained without amplitude attenuation of an output signal due to the TFT threshold value. In addition, a capacitor (155) formed between a gate electrode and an output electrode of a TFT (153) compensates for increasing the electric potential of the gate electrode of the TFT (152), and a larger load driving capability is obtained.

(52) **U.S. Cl.**
USPC **326/88**; 345/211; 345/212; 345/204;
345/94; 345/100; 257/E29.06; 257/E29.061;
257/E29.068; 257/E21.461; 438/104; 438/149;
438/151; 438/161; 326/81; 326/83

(58) **Field of Classification Search**
USPC 257/43, 84, 98, 411, E21.461, E29.068,
257/E29.095, E29.255, E29.273, E33.012;

24 Claims, 22 Drawing Sheets

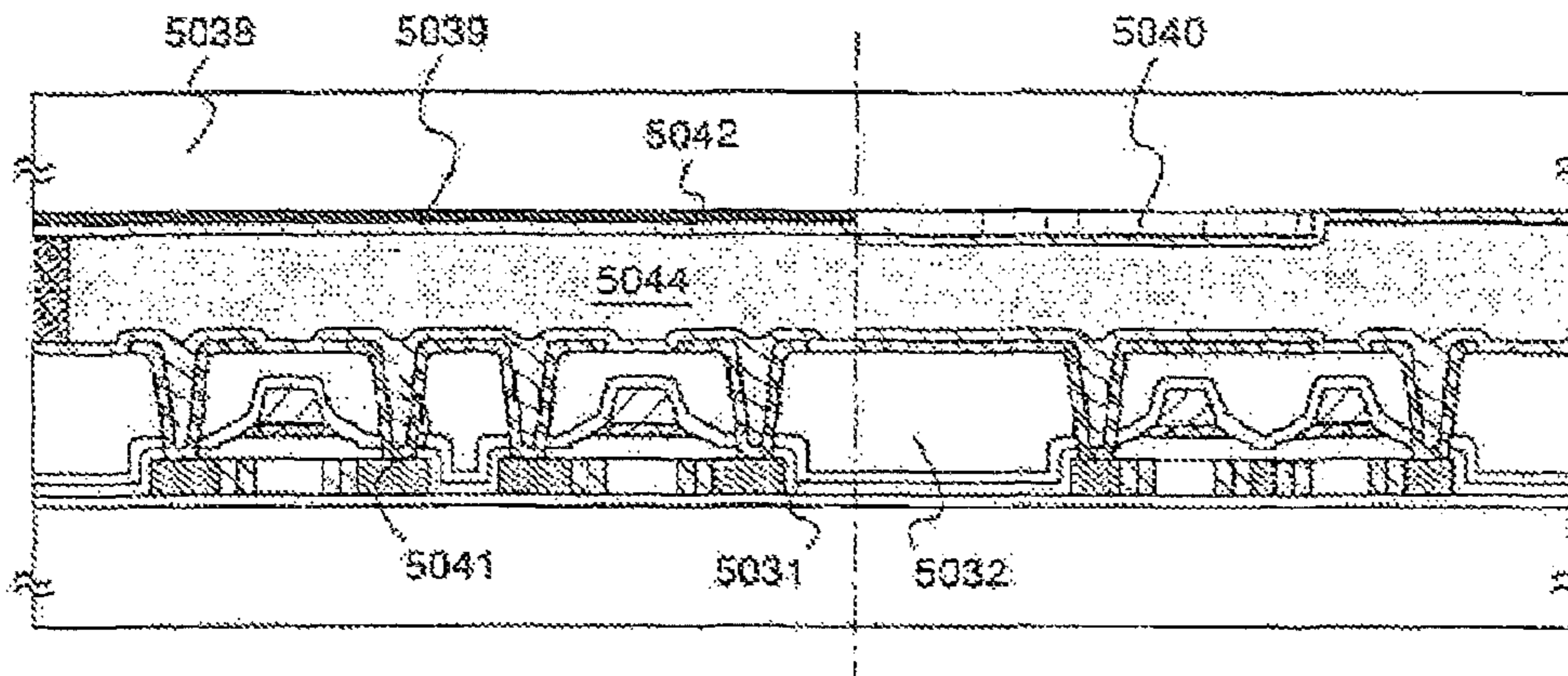

(56)

References Cited

FOREIGN PATENT DOCUMENTS

U.S. PATENT DOCUMENTS

3,898,479 A 8/1975 Proebsting
 4,090,096 A 5/1978 Nagami
 4,390,803 A 6/1983 Koike
 4,412,139 A 10/1983 Horninger
 4,443,714 A 4/1984 Nakano et al.
 4,582,395 A 4/1986 Morozumi
 4,633,105 A 12/1986 Tsujimoto
 4,804,870 A 2/1989 Mahmud
 4,959,697 A 9/1990 Shier et al.
 5,467,038 A 11/1995 Motley et al.
 5,548,143 A 8/1996 Lee
 5,643,826 A 7/1997 Ohtani et al.
 5,694,061 A 12/1997 Morosawa et al.
 5,870,071 A 2/1999 Kawahata
 5,889,291 A 3/1999 Koyama et al.
 5,949,271 A 9/1999 Fujikura
 5,949,398 A 9/1999 Kim
 5,952,991 A 9/1999 Akiyama
 6,040,810 A 3/2000 Nishimura
 6,049,228 A 4/2000 Moon
 6,091,393 A 7/2000 Park
 6,384,804 B1 5/2002 Dodabalapur et al.
 6,501,098 B2 12/2002 Yamazaki
 6,522,323 B1 2/2003 Sasaki et al.
 6,542,138 B1 4/2003 Shannon et al.
 6,686,899 B2 2/2004 Miyazawa et al.
 6,788,108 B2 9/2004 Miyake et al.
 6,813,332 B2 11/2004 Nagao et al.
 7,091,749 B2 8/2006 Miyake et al.
 7,307,463 B2 12/2007 Miyake et al.
 RE41,215 E 4/2010 Miyake et al.
 7,847,593 B2 12/2010 Yoshida
 2001/0002703 A1 6/2001 Koyama
 2001/0045565 A1 11/2001 Yamazaki
 2002/0011973 A1 1/2002 Komiya
 2002/0044208 A1 4/2002 Yamazaki et al.
 2002/0089496 A1 7/2002 Numao
 2002/0097212 A1 7/2002 Miyazawa et al.
 2002/0158666 A1 10/2002 Azami et al.
 2002/0167026 A1 11/2002 Azami et al.
 2002/0190326 A1 12/2002 Nagao et al.
 2003/0011584 A1 1/2003 Azami et al.
 2003/0020520 A1 1/2003 Miyake et al.
 2003/0034806 A1 2/2003 Azami
 2003/0052324 A1 3/2003 Kimura
 2003/0111677 A1 6/2003 Miyake
 2004/0252111 A1 12/2004 Cheon et al.
 2004/0257353 A1 12/2004 Imamura et al.

EP 1 063 630 12/2000
 EP 1063630 A2 12/2000
 EP 1 139 326 10/2001
 EP 1139326 A2 10/2001
 JP 55-156427 12/1980
 JP 55-156427 A 12/1980
 JP 56-093431 7/1981
 JP 56-093431 A 7/1981
 JP 57-106228 7/1982
 JP 57-106228 A 7/1982
 JP 57-132191 8/1982
 JP 57-132191 A 8/1982
 JP 59-16424 1/1984
 JP 59-016424 A 1/1984
 JP 60-140924 7/1985
 JP 600140924 A 7/1985
 JP 63-204815 8/1988
 JP 63-204815 A 8/1988
 JP 03-165171 7/1991
 JP 03-165171 A 7/1991
 JP 06-098081 4/1994
 JP 06-098081 A 4/1994
 JP 08-051219 2/1996
 JP 08-051219 A 2/1996
 JP 09-046216 2/1997
 JP 09-046216 A 2/1997
 JP 09-186312 7/1997
 JP 09-186312 A 7/1997
 JP 09-246936 9/1997
 JP 09-246936 A 9/1997
 JP 2000-106617 4/2000
 JP 2000-106617 A 4/2000
 JP 2001-005426 1/2001
 JP 2001-005426 A 1/2001
 JP 2001-109394 4/2001
 JP 2001-109394 A 4/2001
 JP 2001-133431 5/2001
 JP 2001-133431 A 5/2001
 JP 2002-176162 6/2002
 JP 2002-176162 A 6/2002
 JP 2002-251164 9/2002
 JP 2002-251164 A 9/2002

OTHER PUBLICATIONS

Japan Office Action (Application No. 2002-221125) mailed Jun. 8, 2004 and full English language translation, 6 pages.
 Office Action (U.S. Appl. No. 10/127,600) dated Oct. 22, 2004, 8 pages.
 Munehiro Azami et al.; U.S. Appl. No. 10/127,600; Office Action dated Oct. 22, 2004.
 US 6,646,476, Nov. 2003, Nagao (withdrawn).

Fig.1A

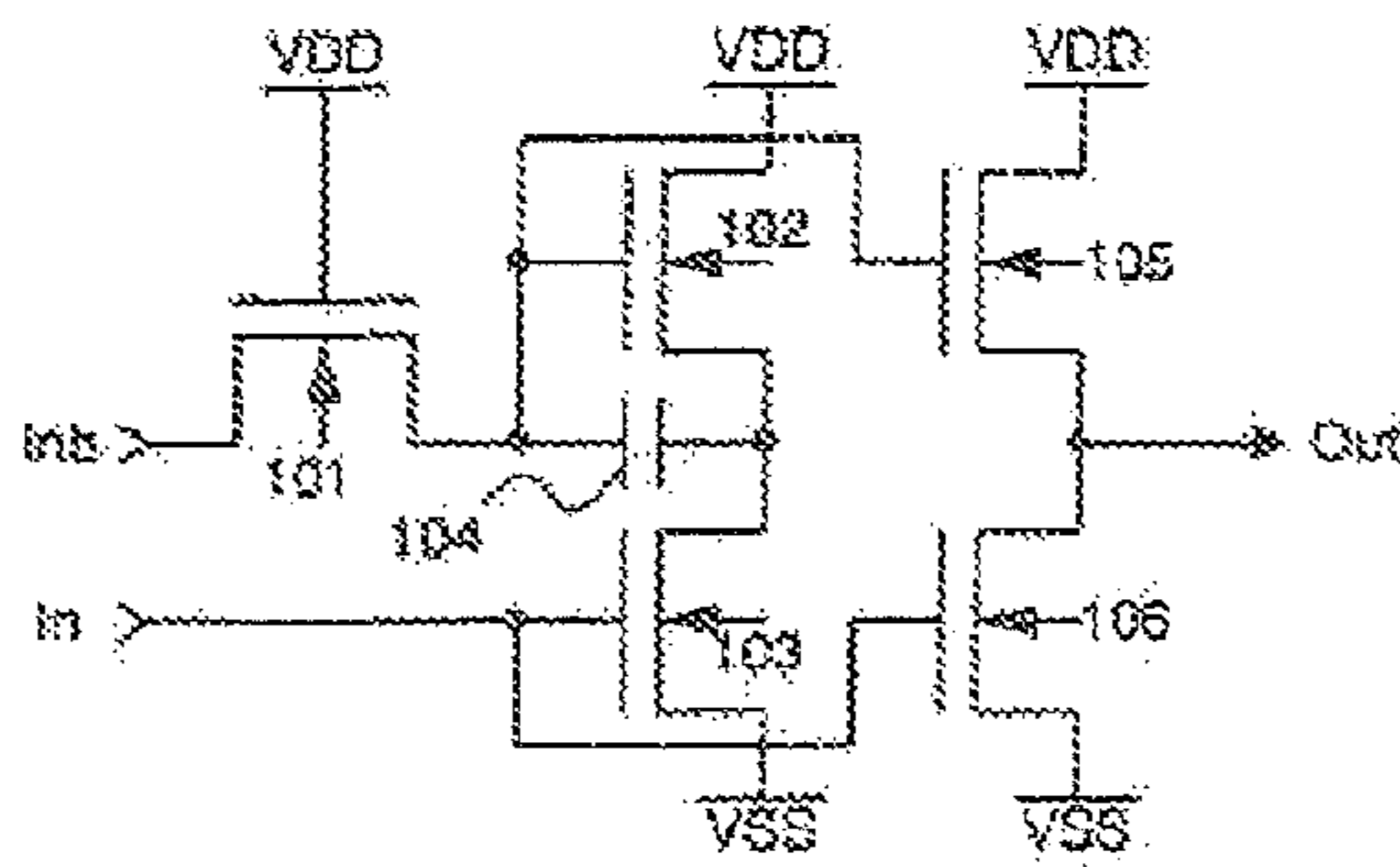

Fig.1B

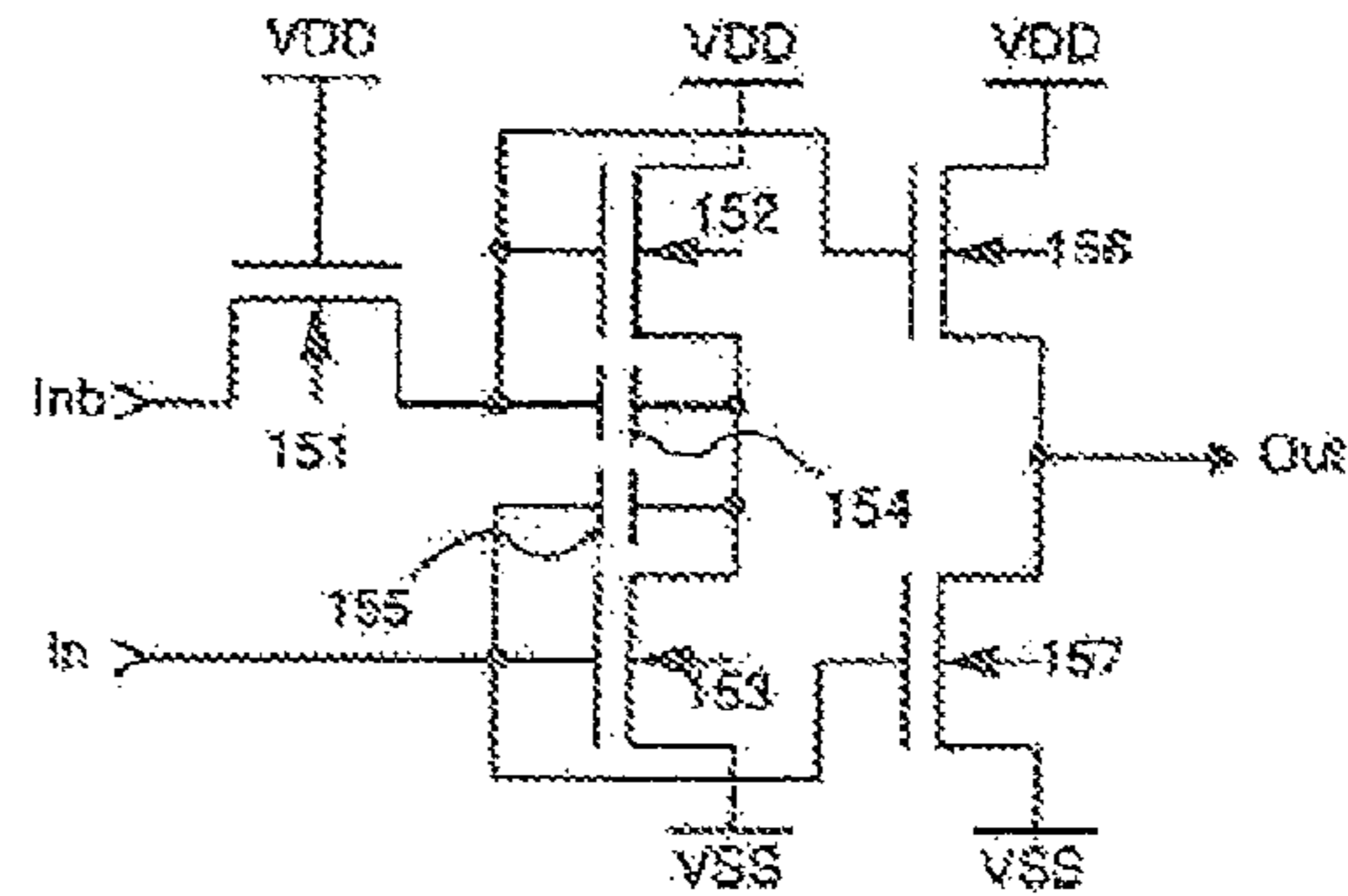

Fig.1C

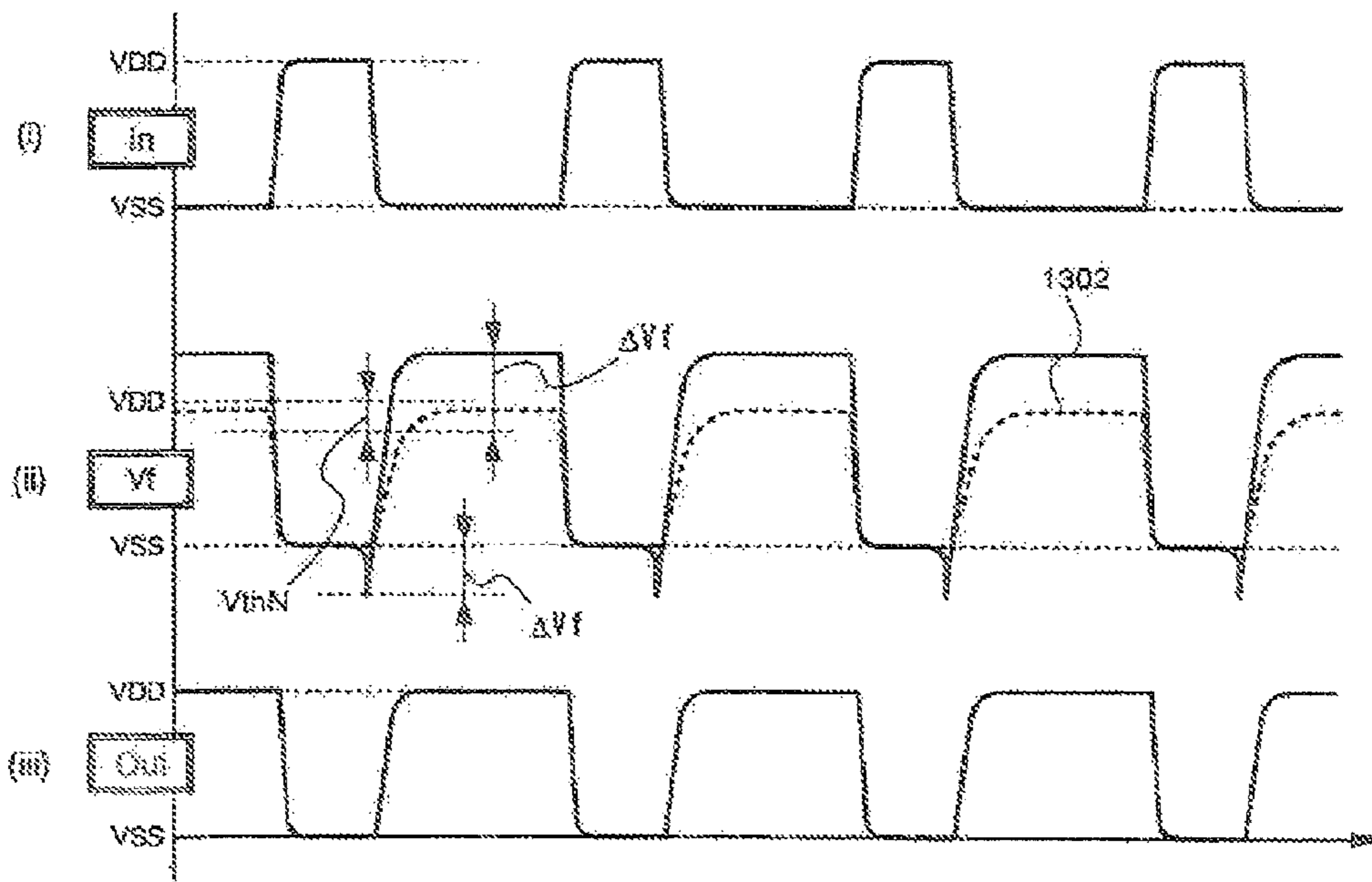

Fig.2A

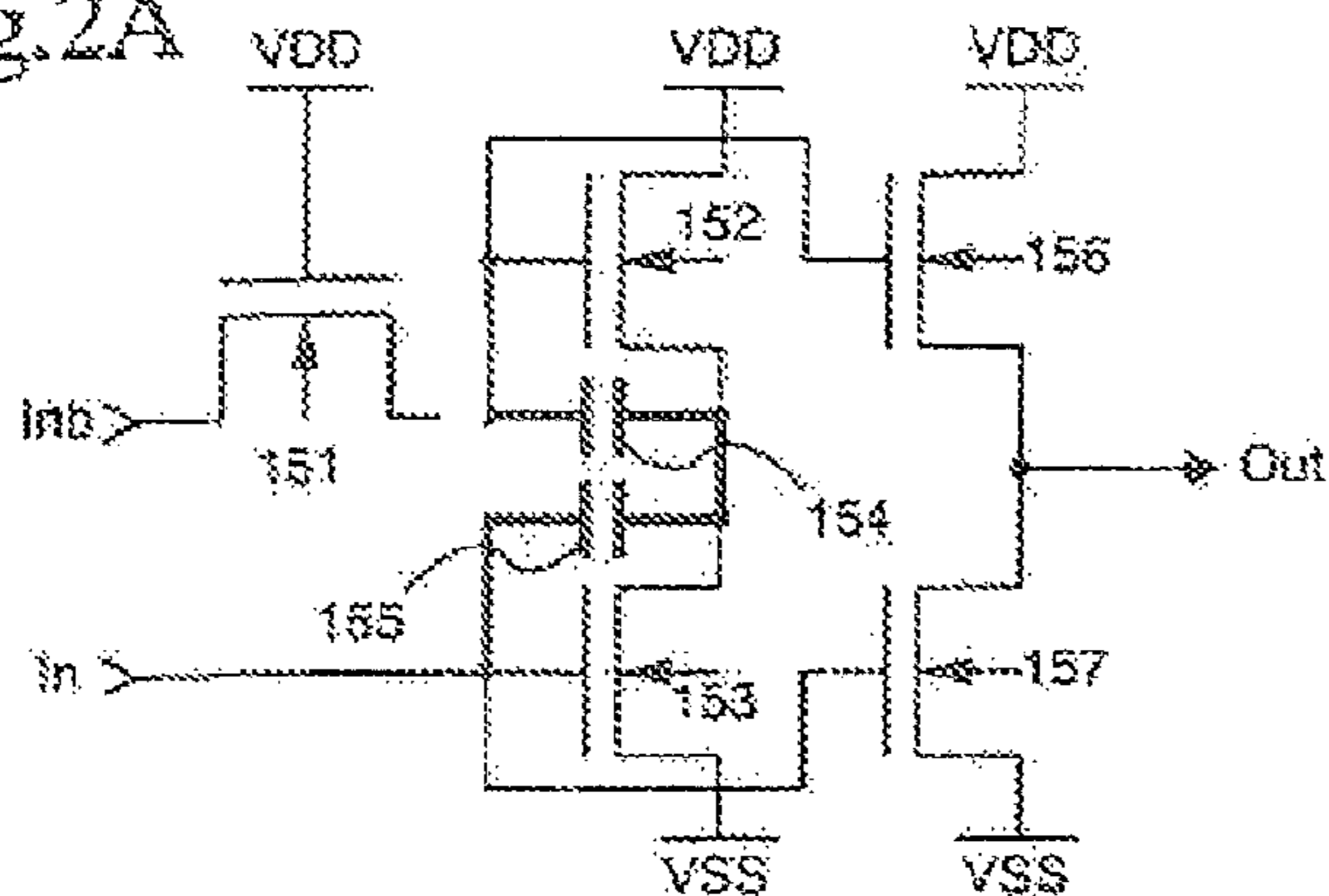

Fig.2B

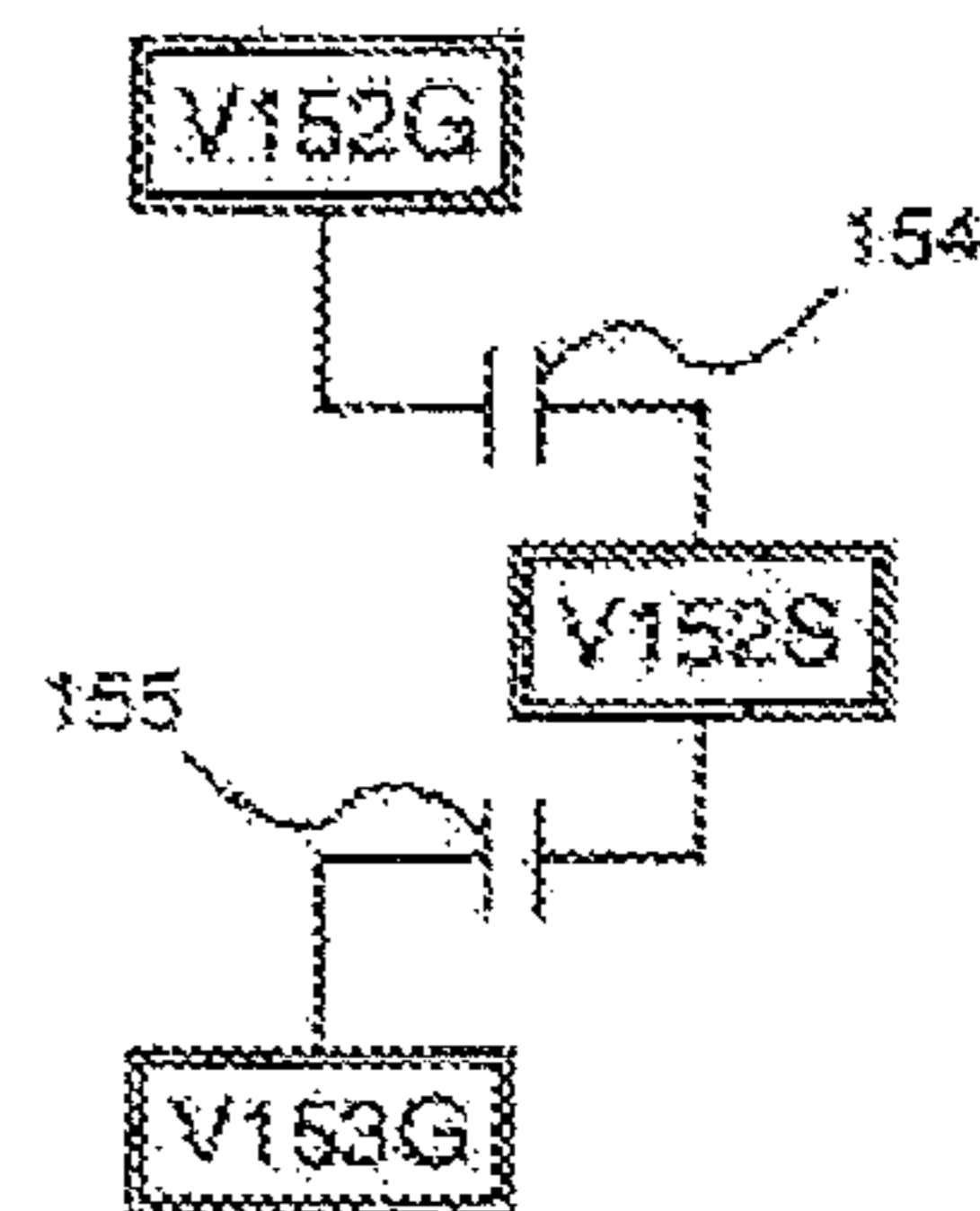

Fig.2C

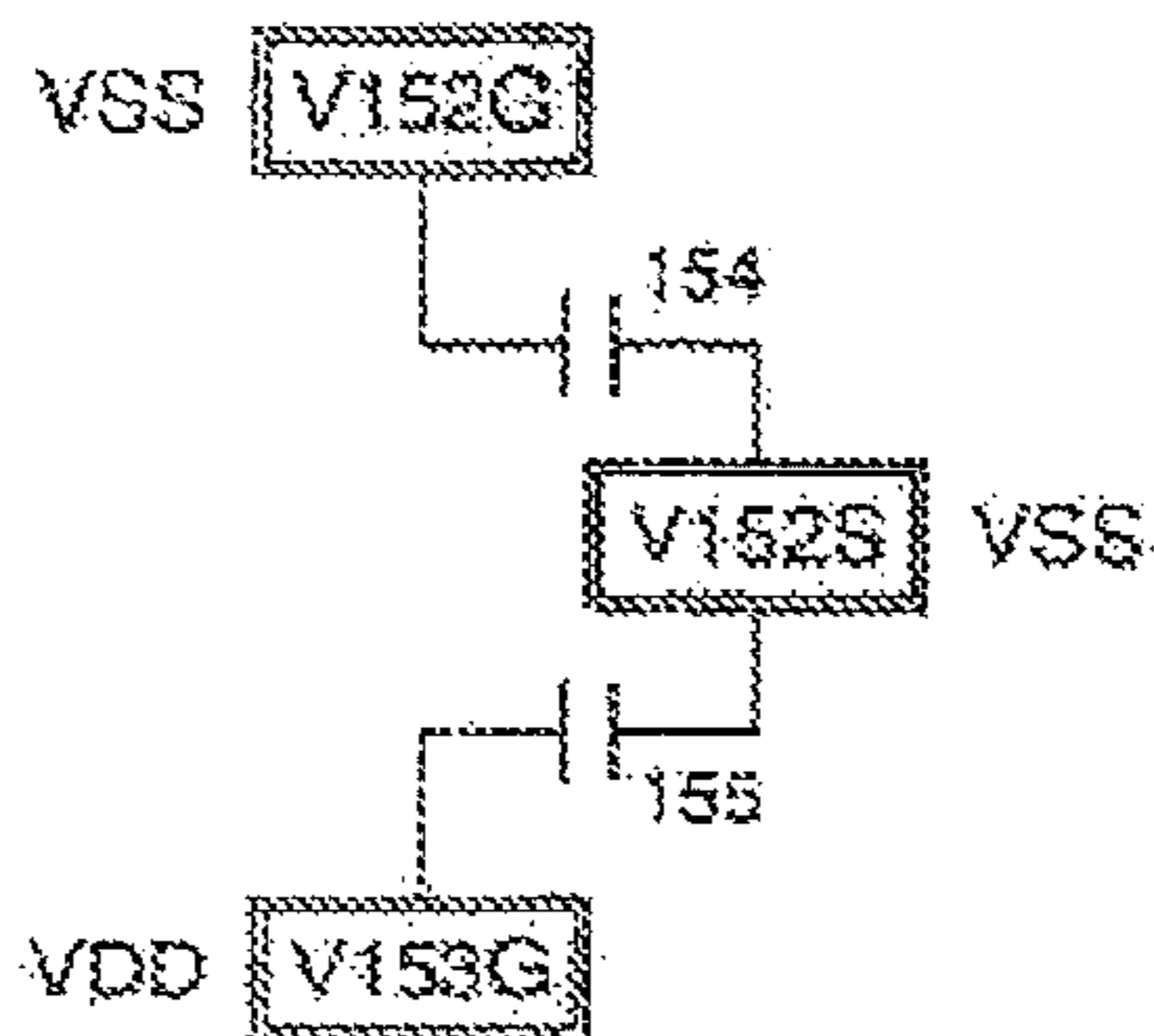

Fig.2D

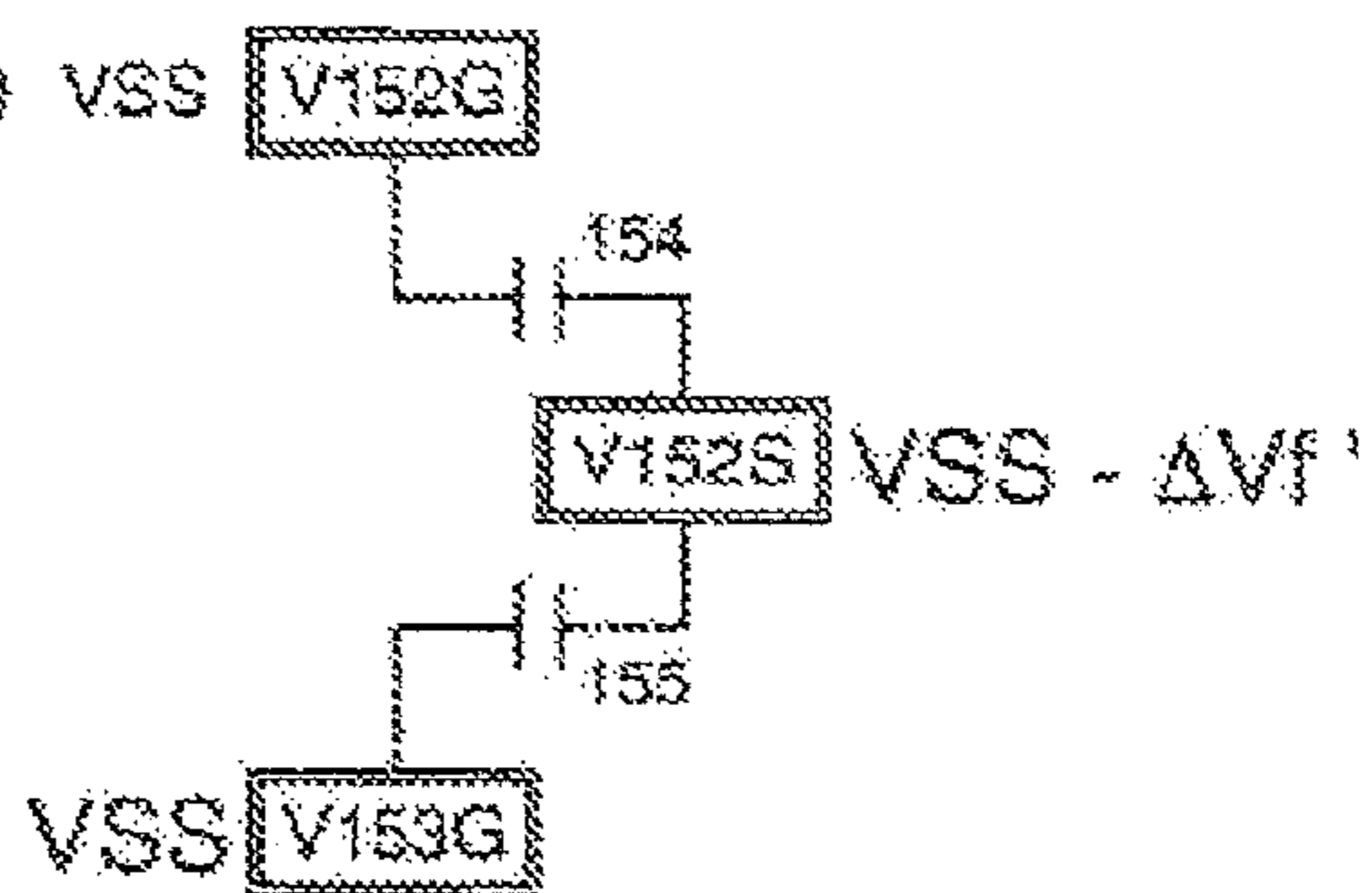

Fig.2E

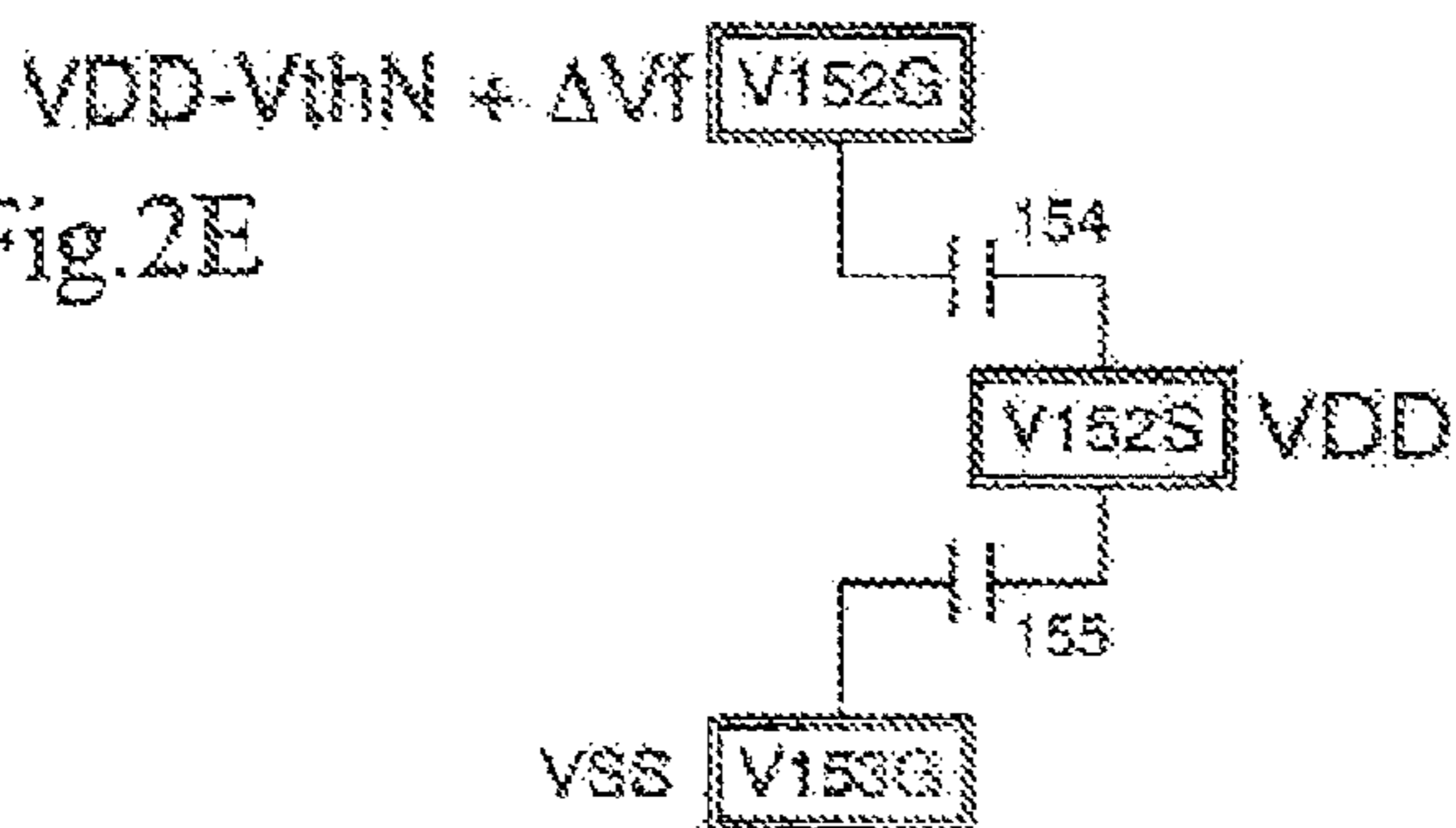

Fig.3

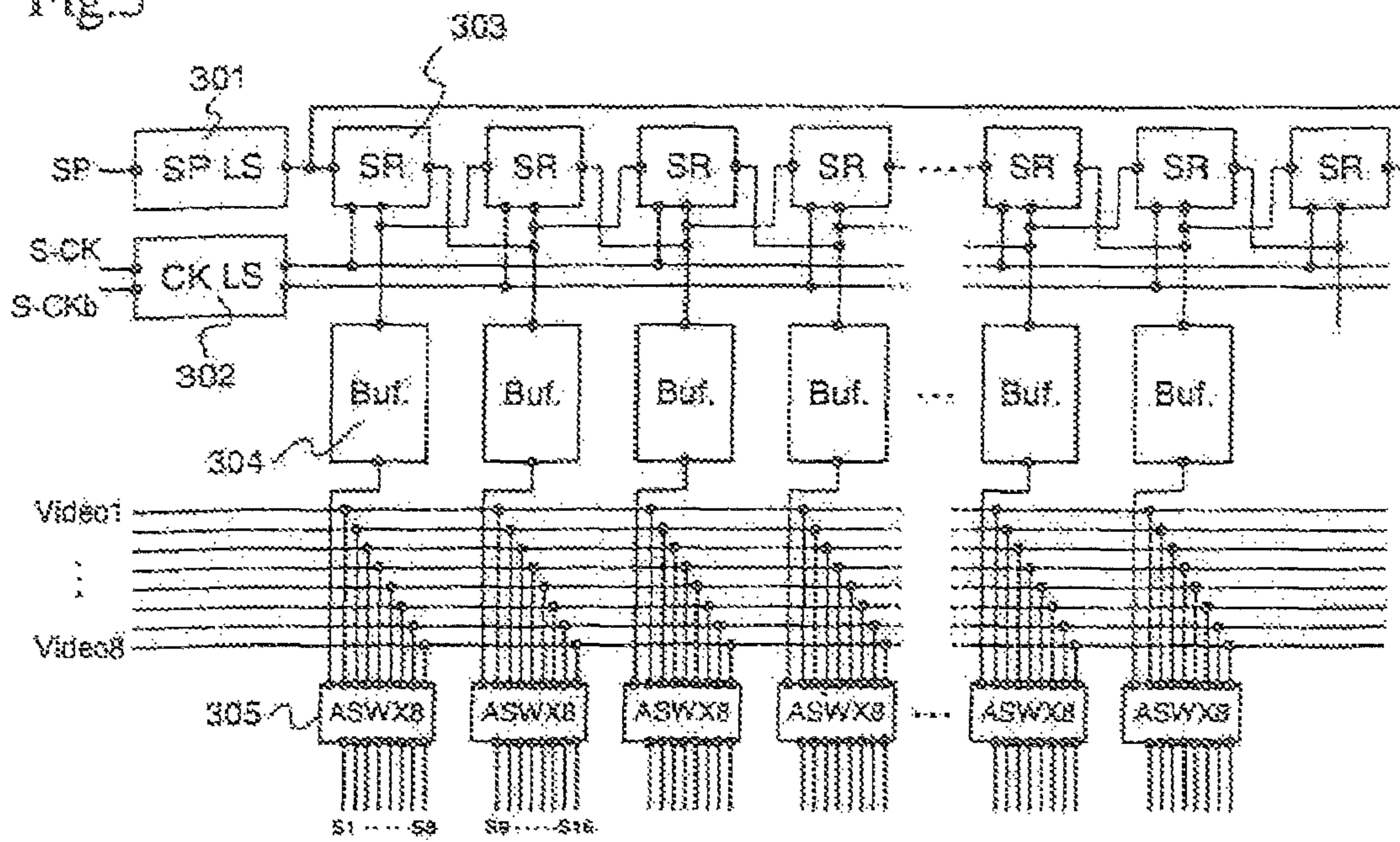

Fig. 4A

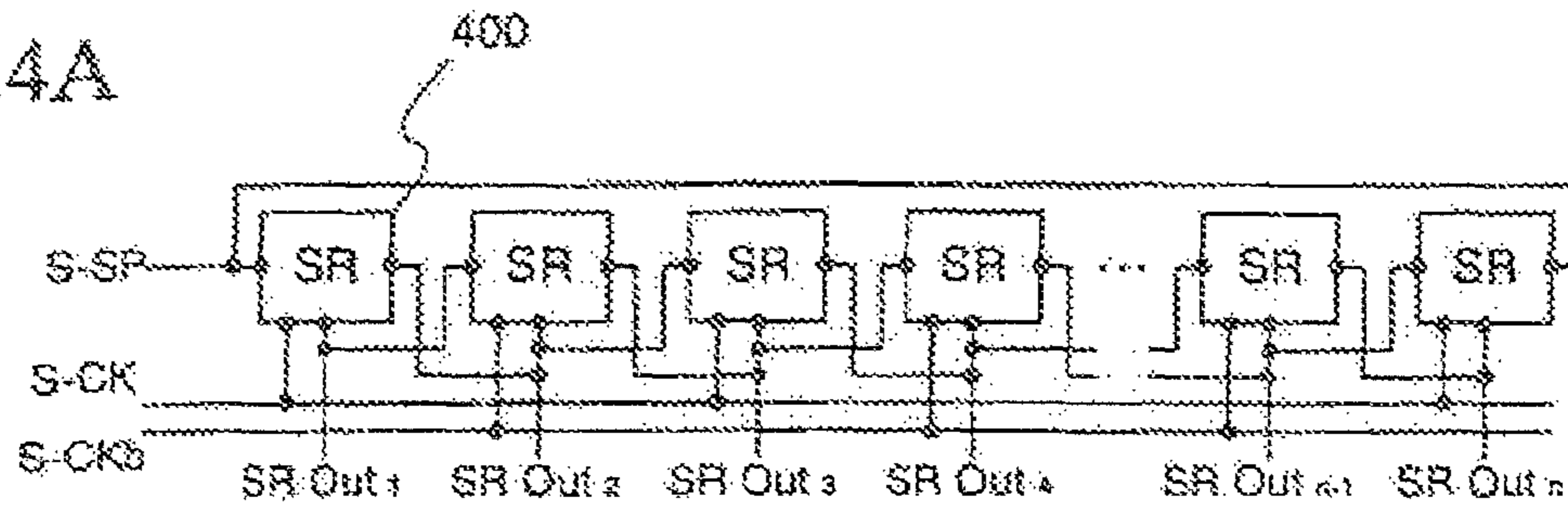
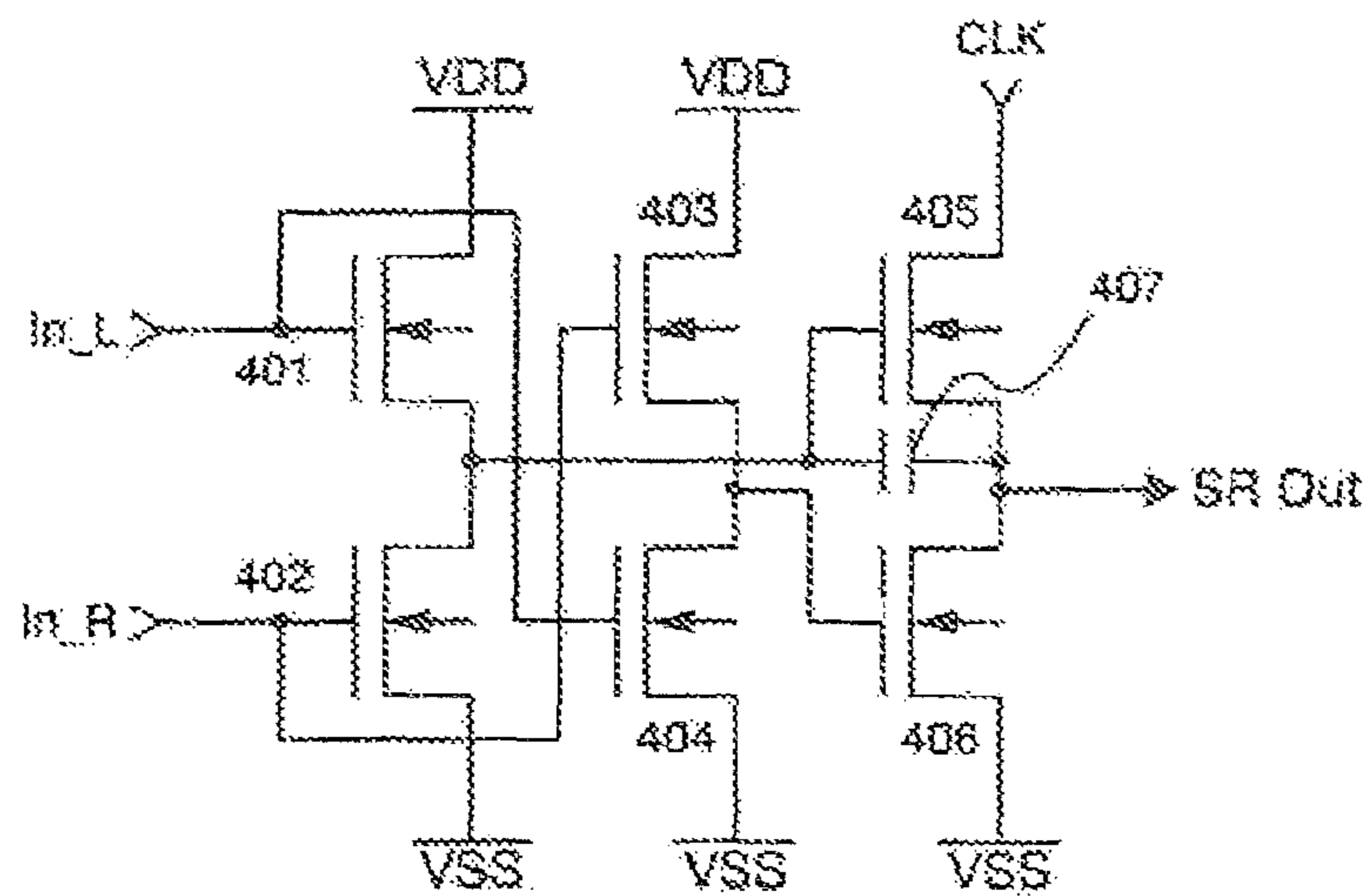
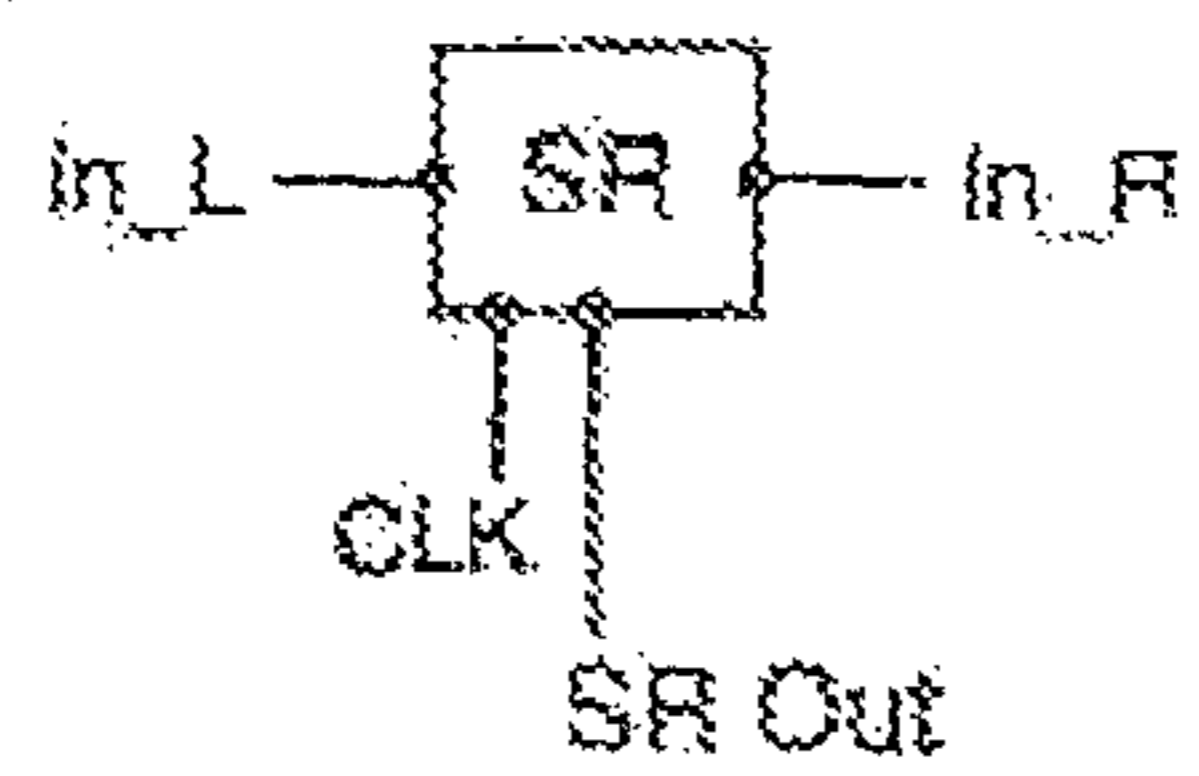
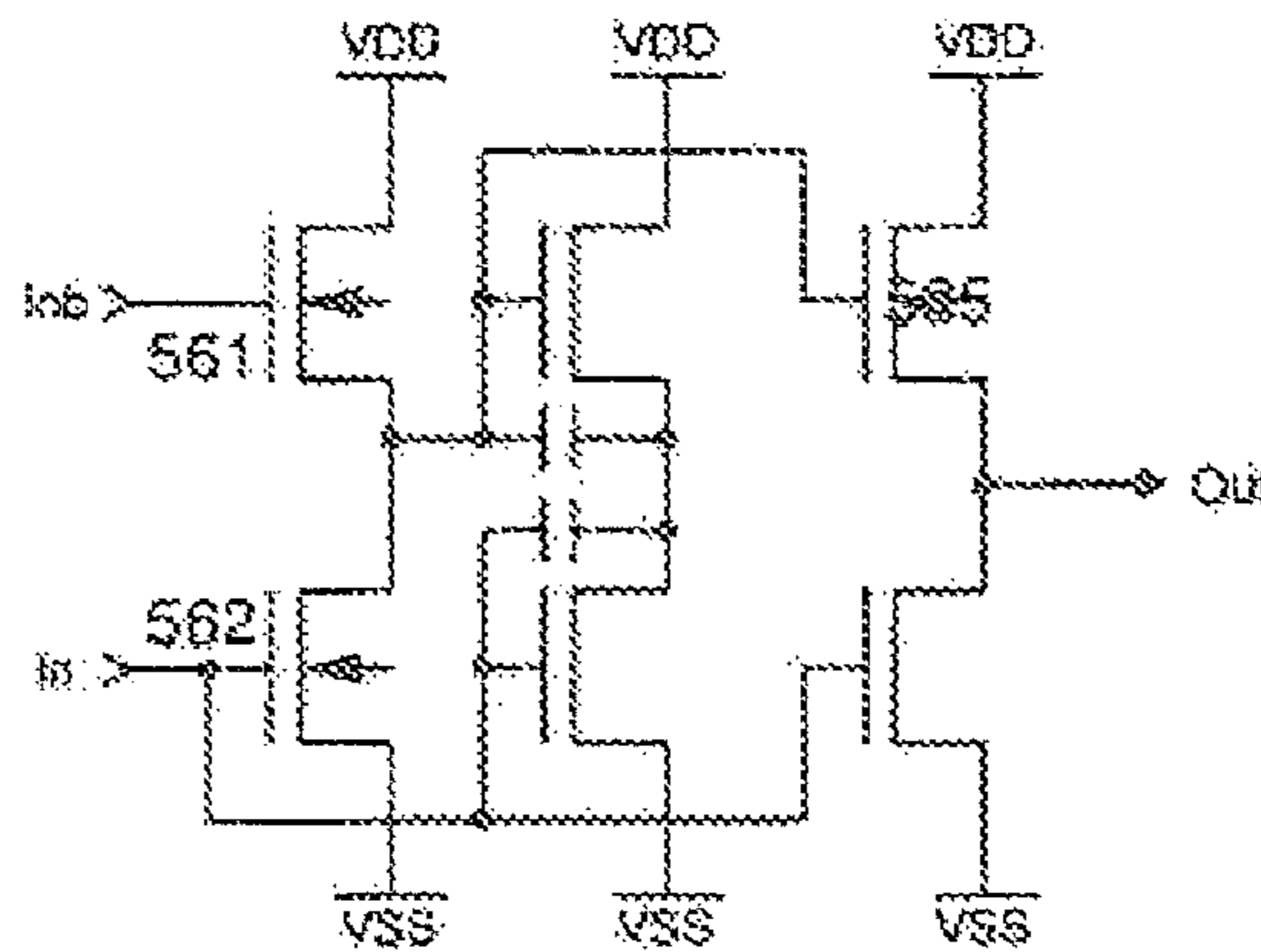
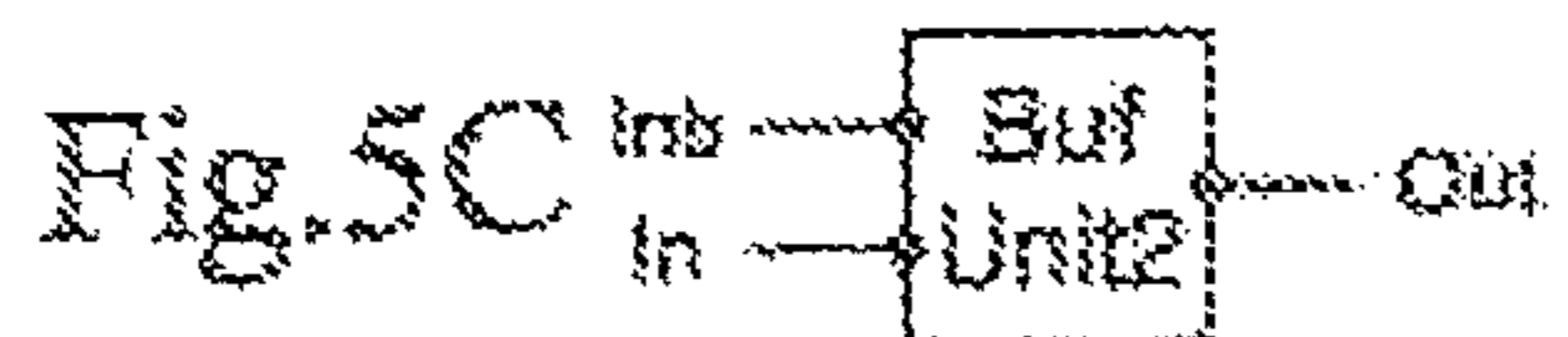
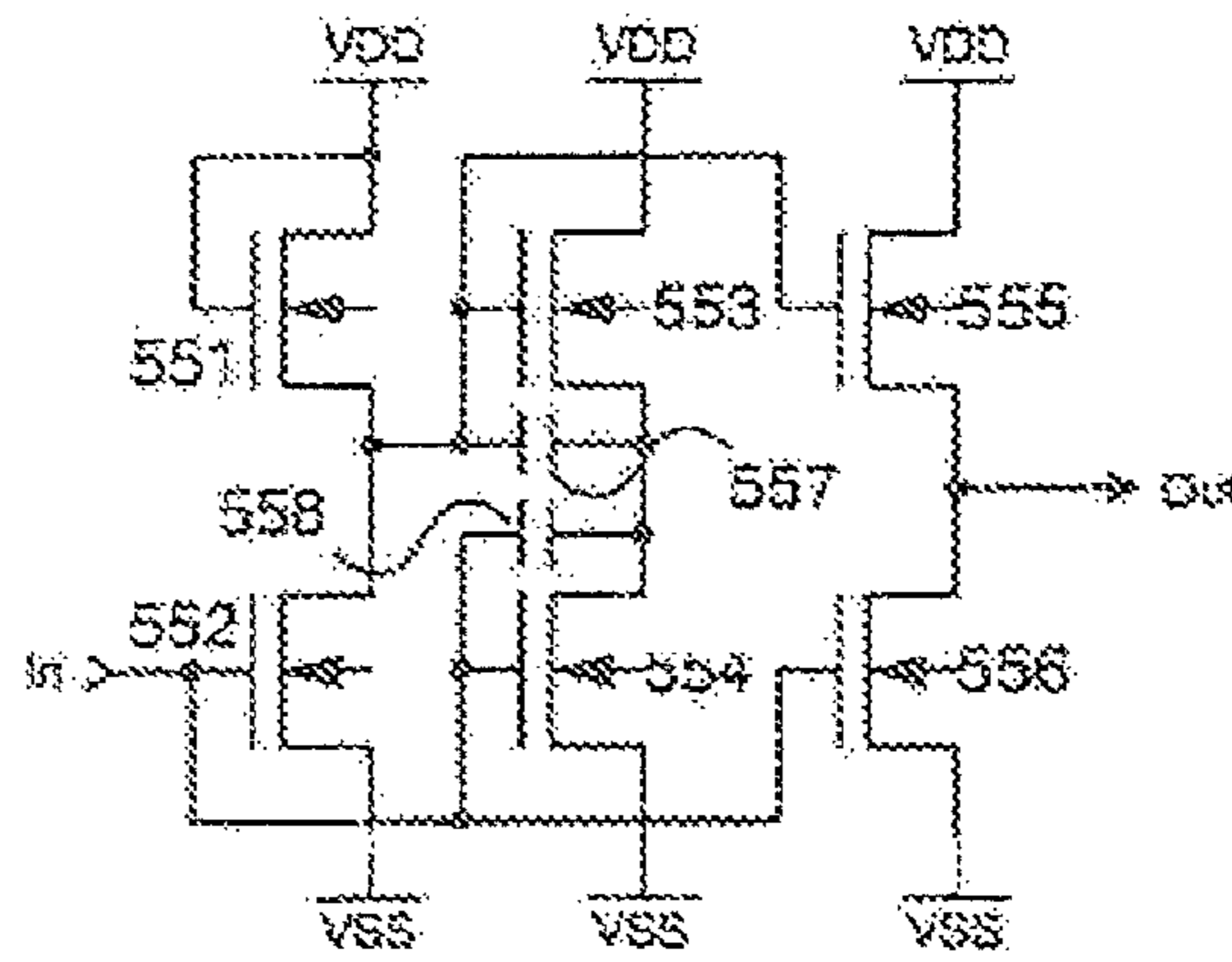
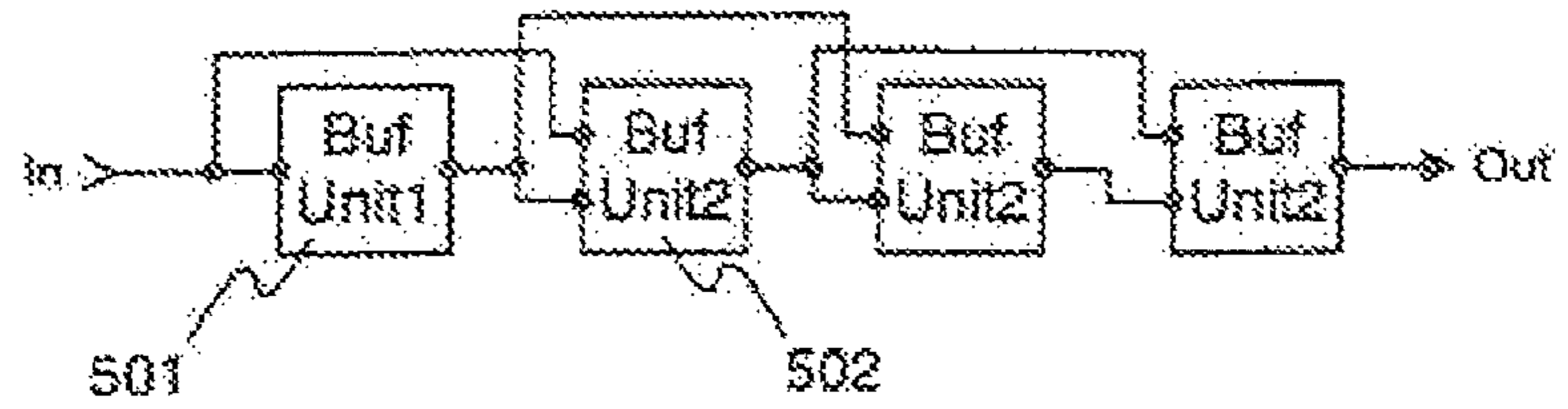
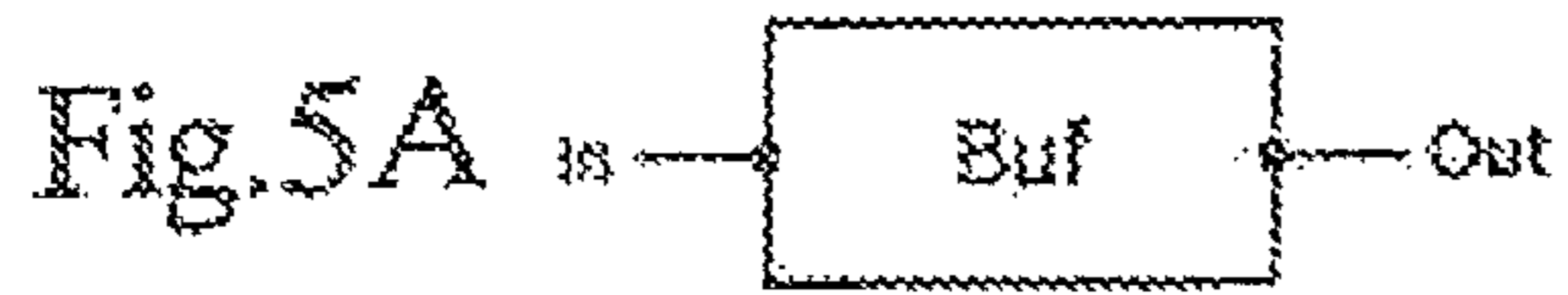
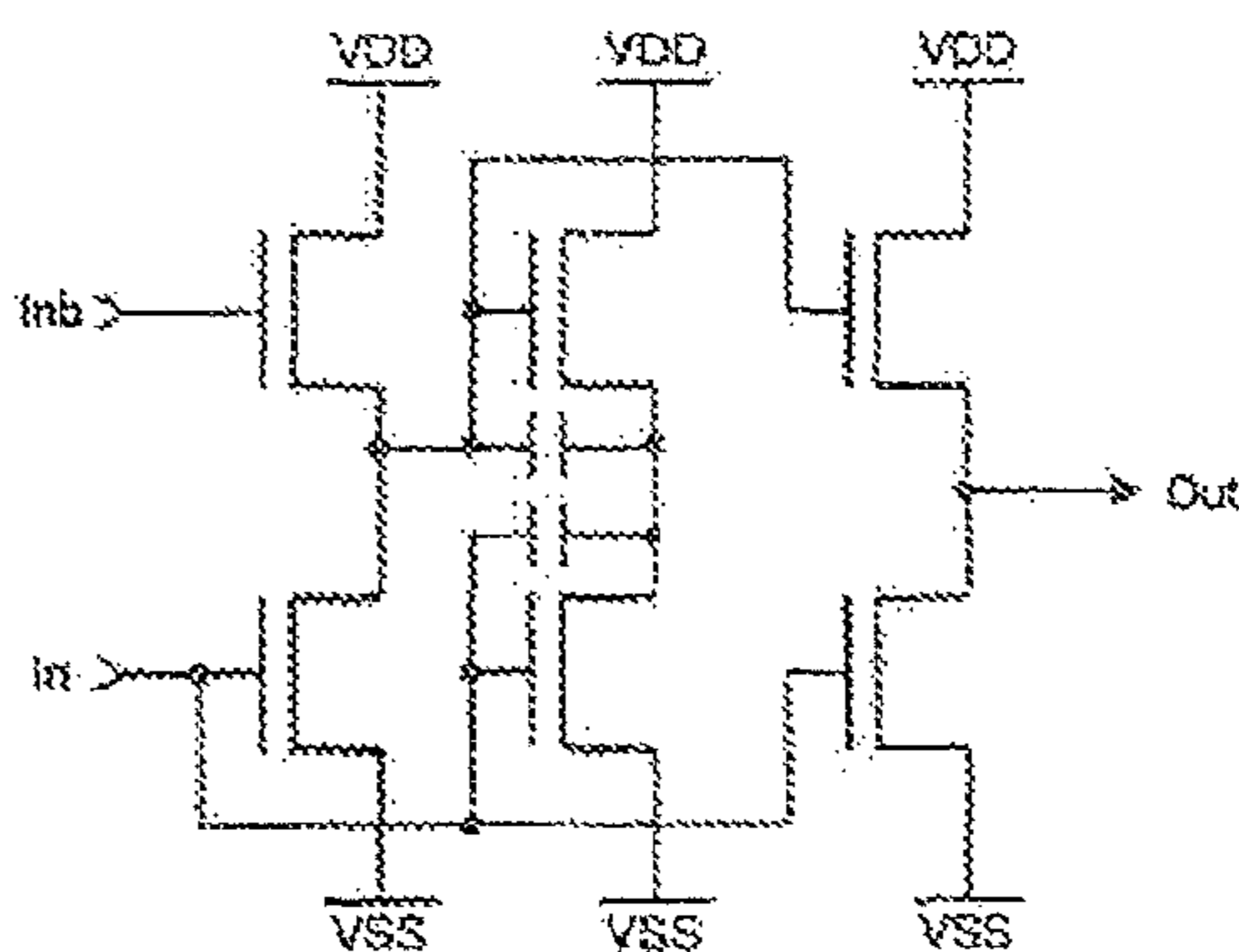
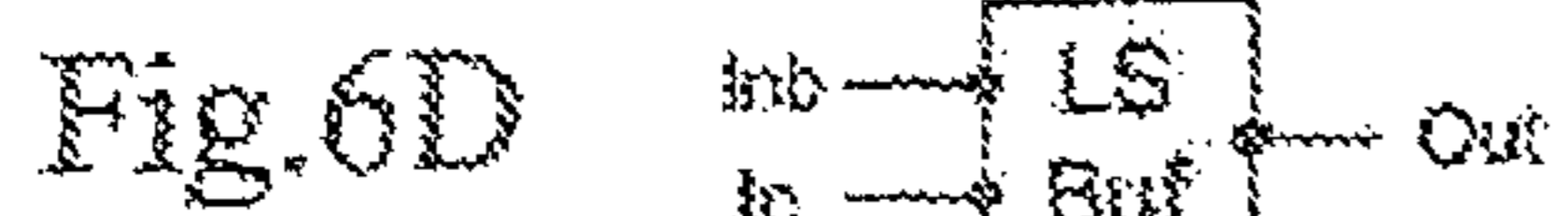
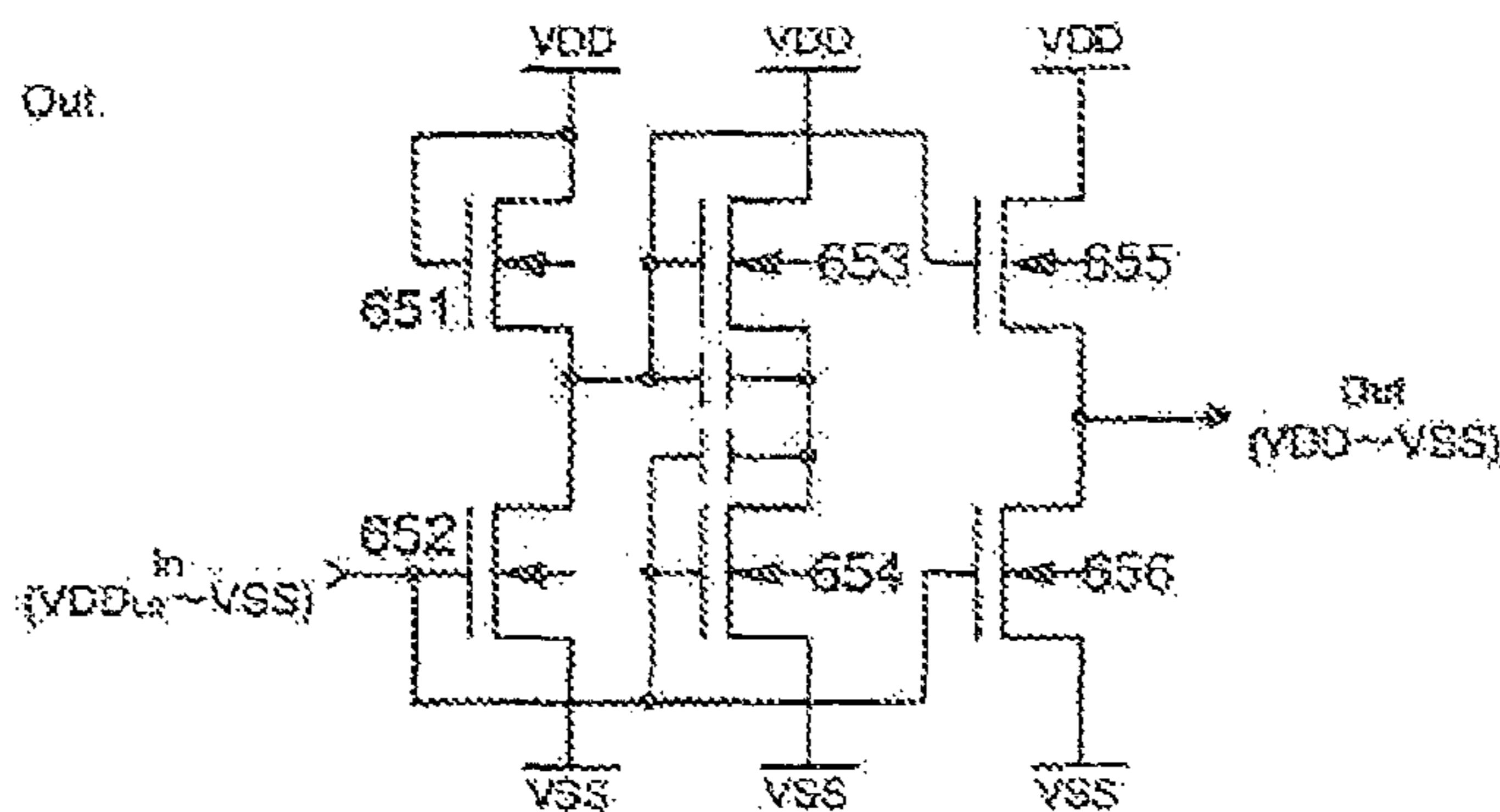
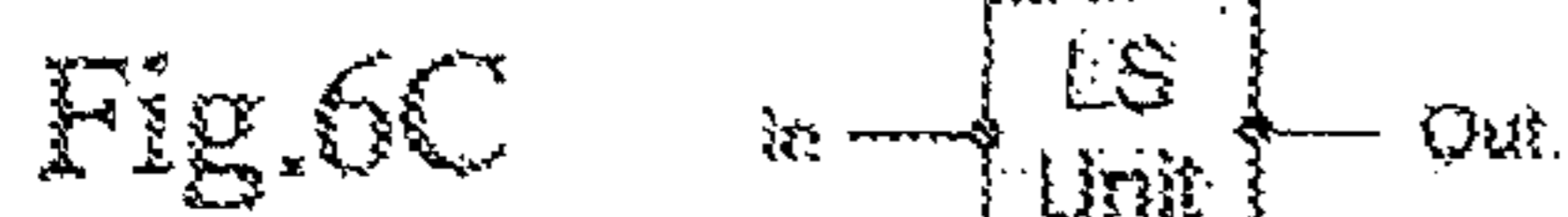
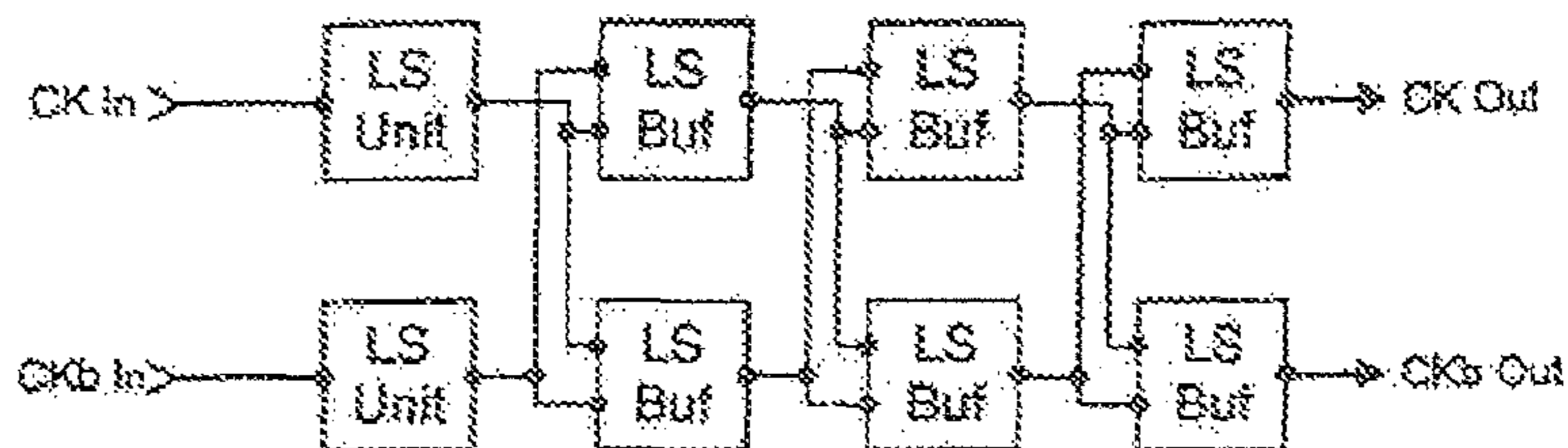
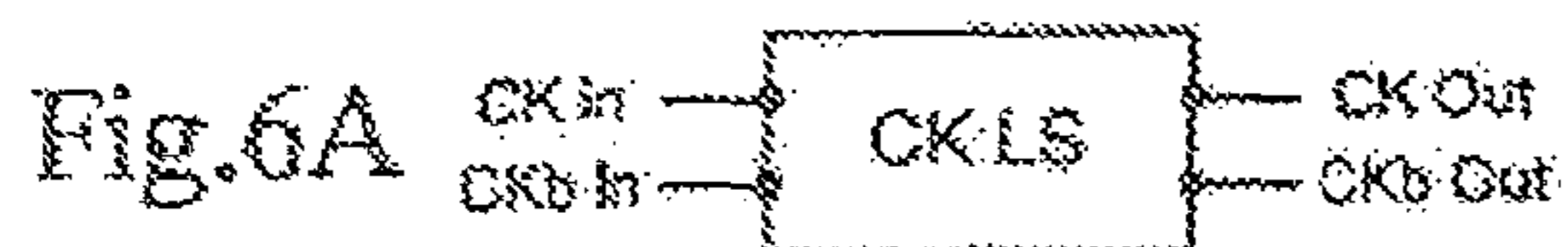

Fig. 4B







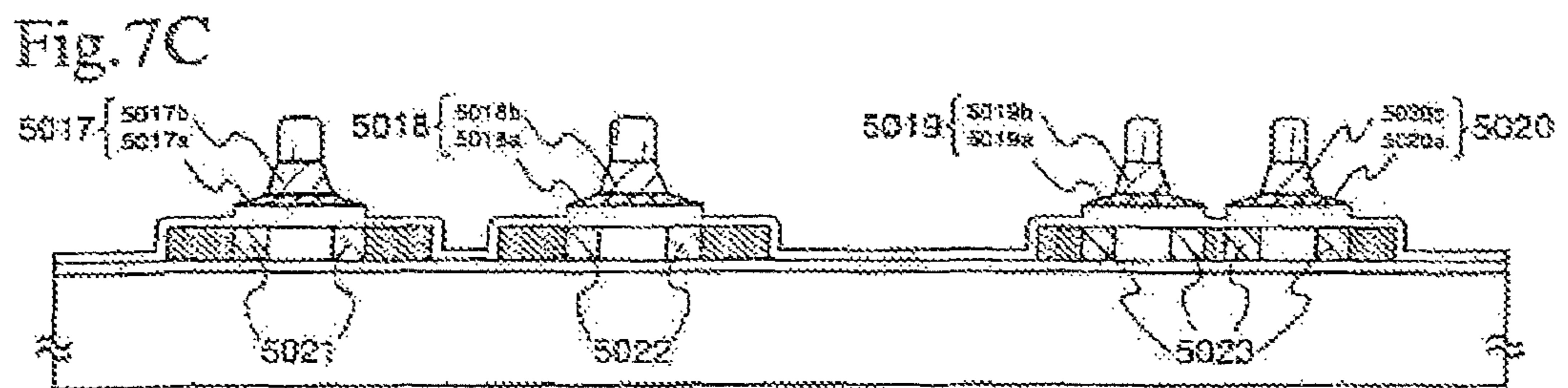
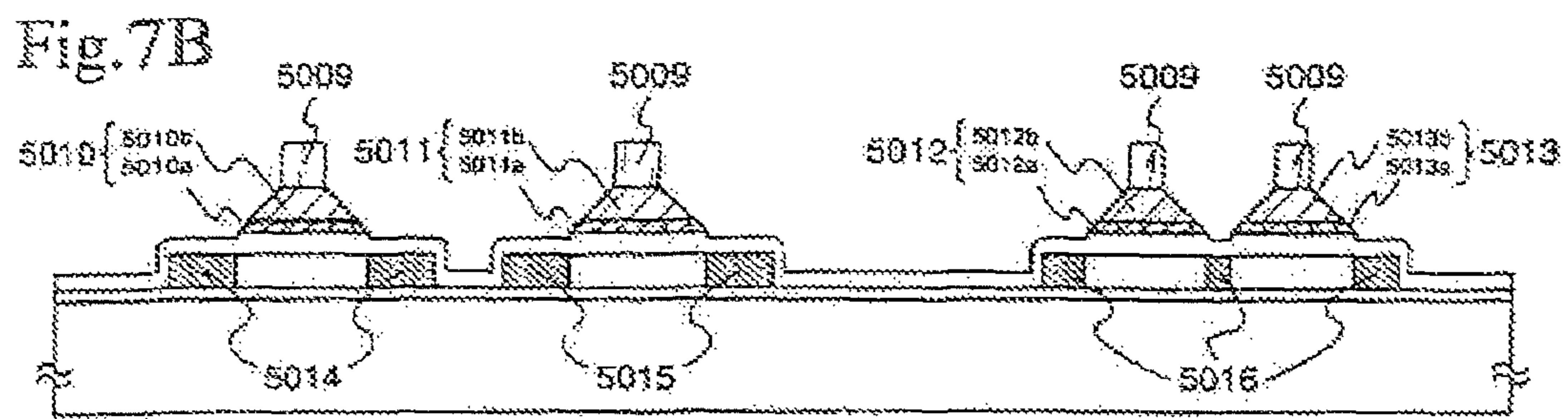
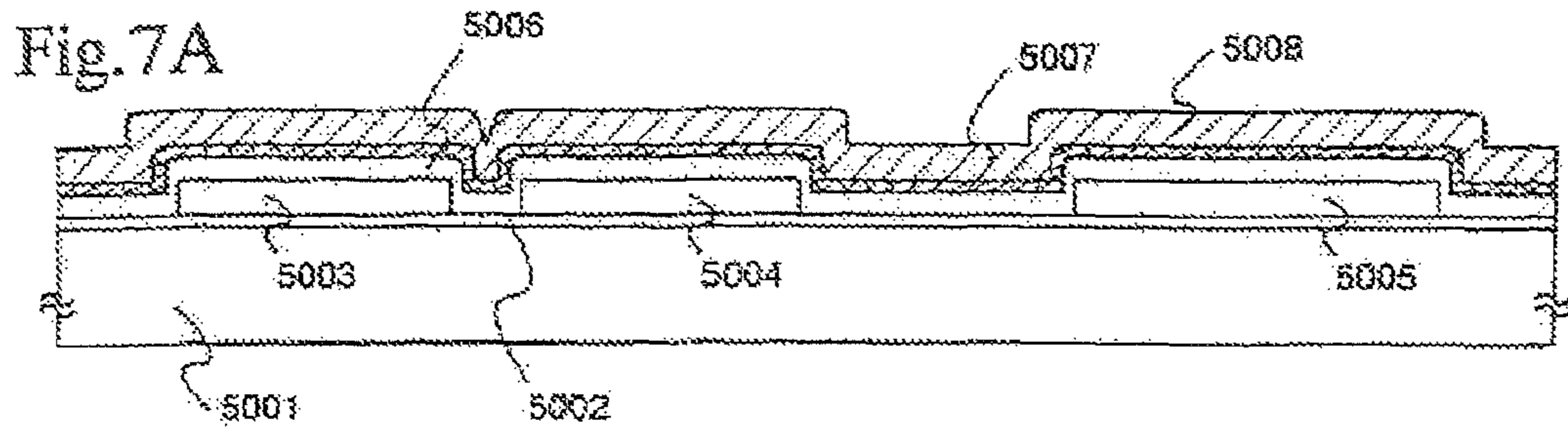

Fig. 8A

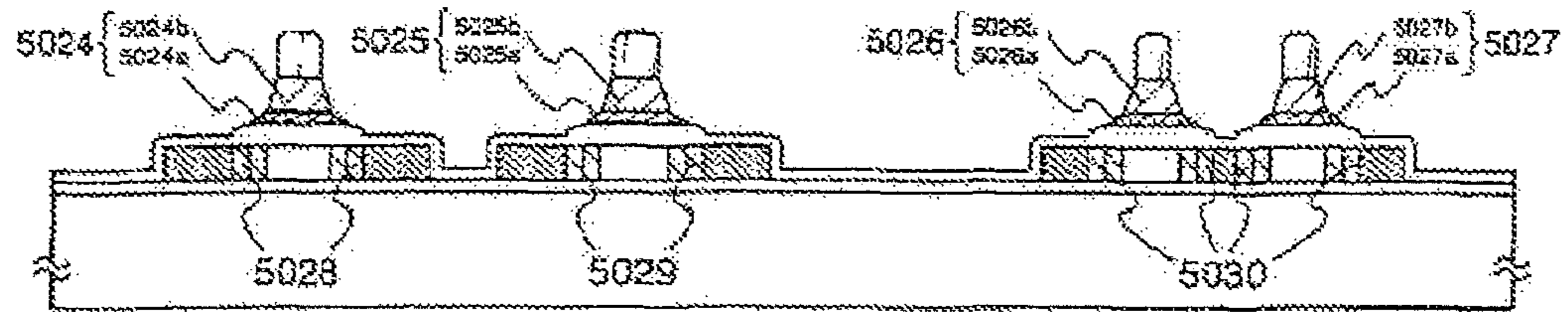

Fig. 8B

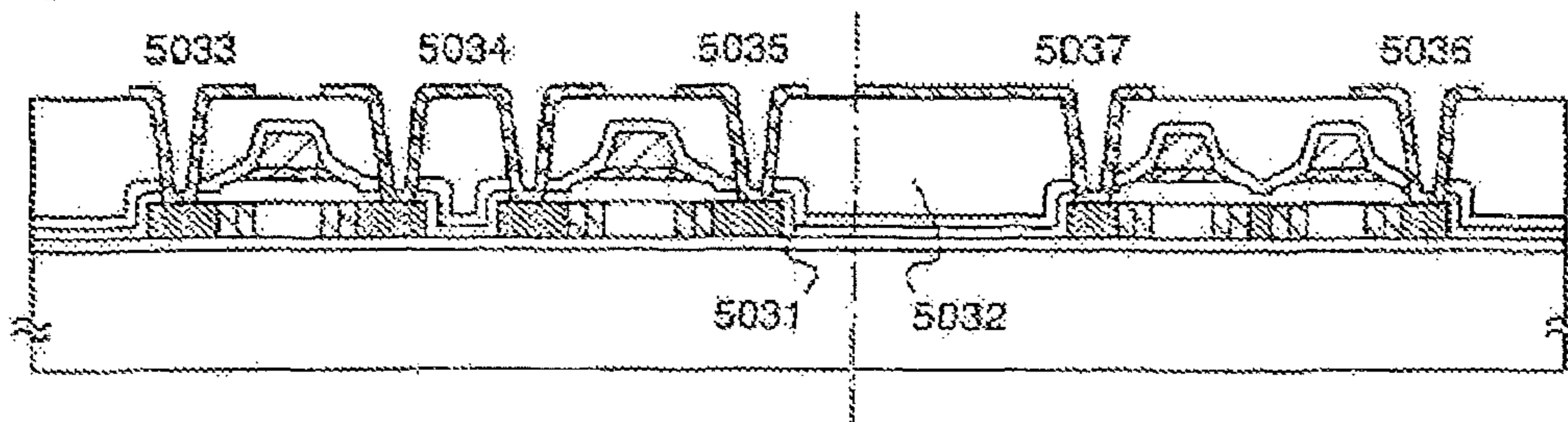

Fig. 8C

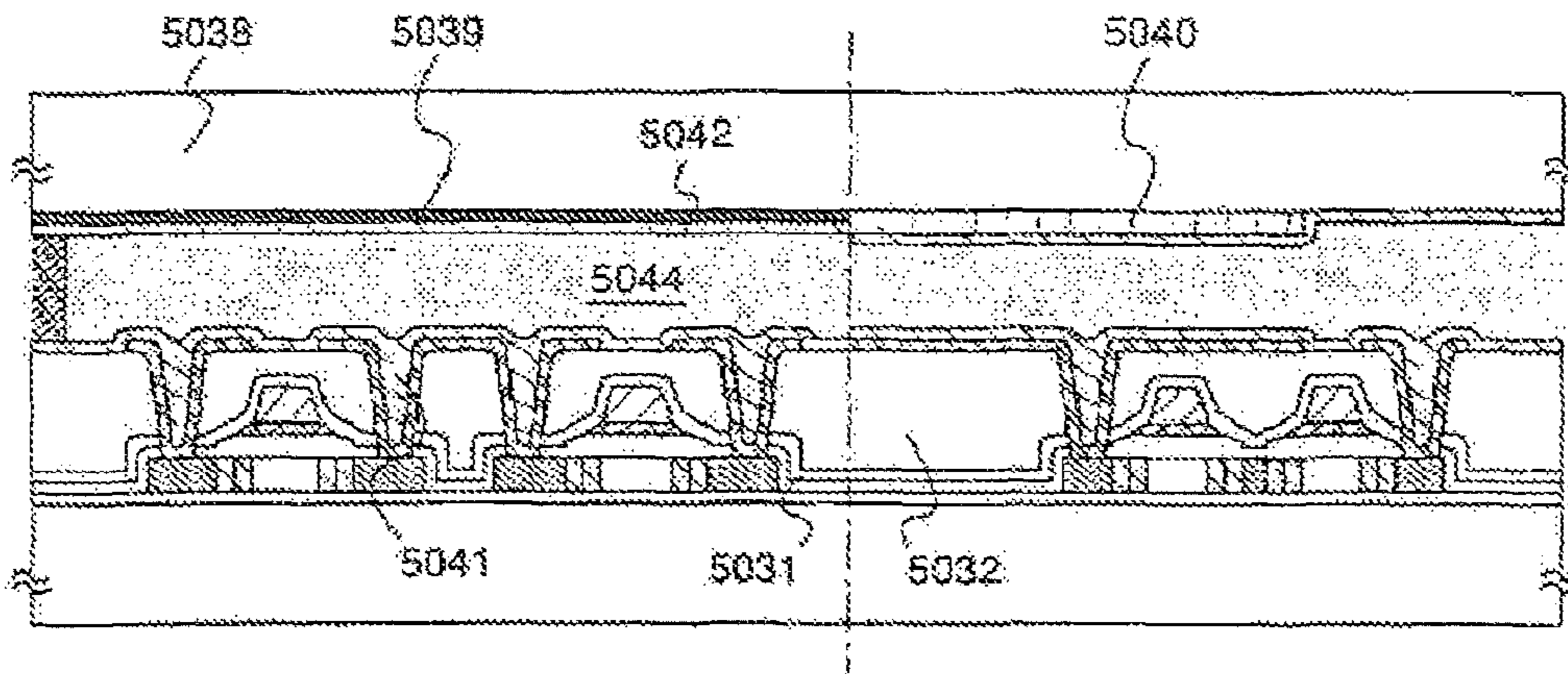

Fig. 9A

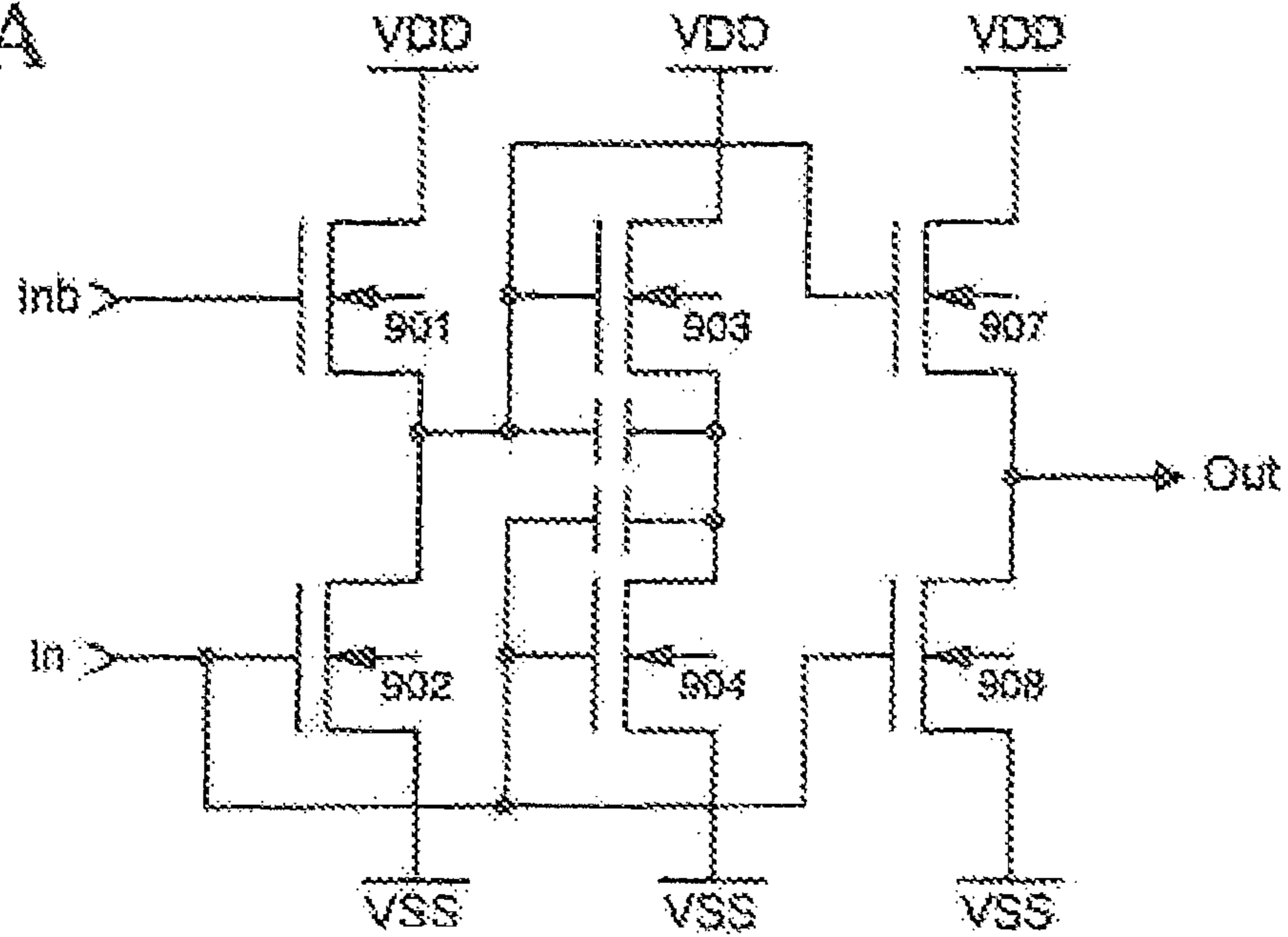

Fig. 9B

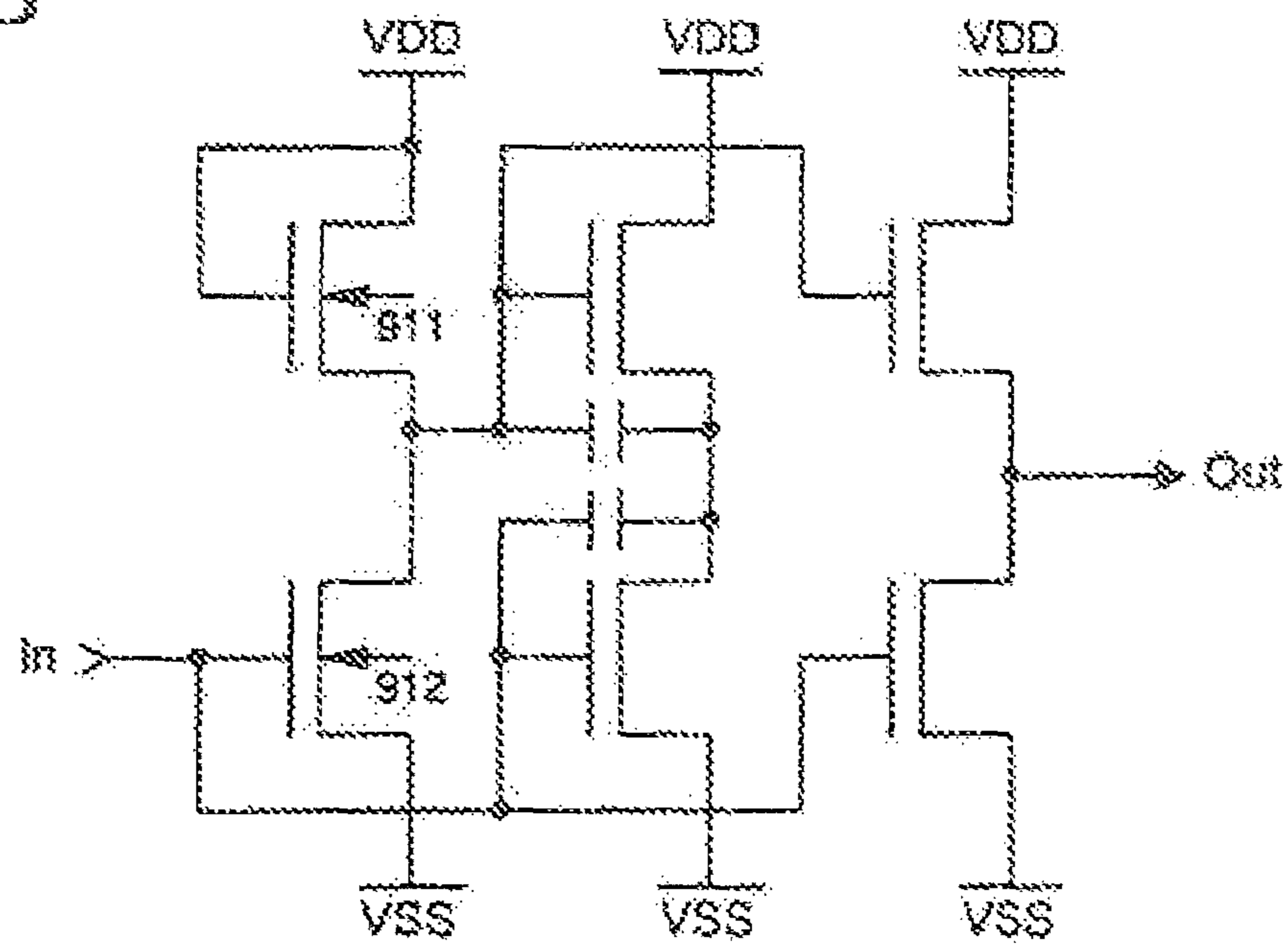

Fig. 10A

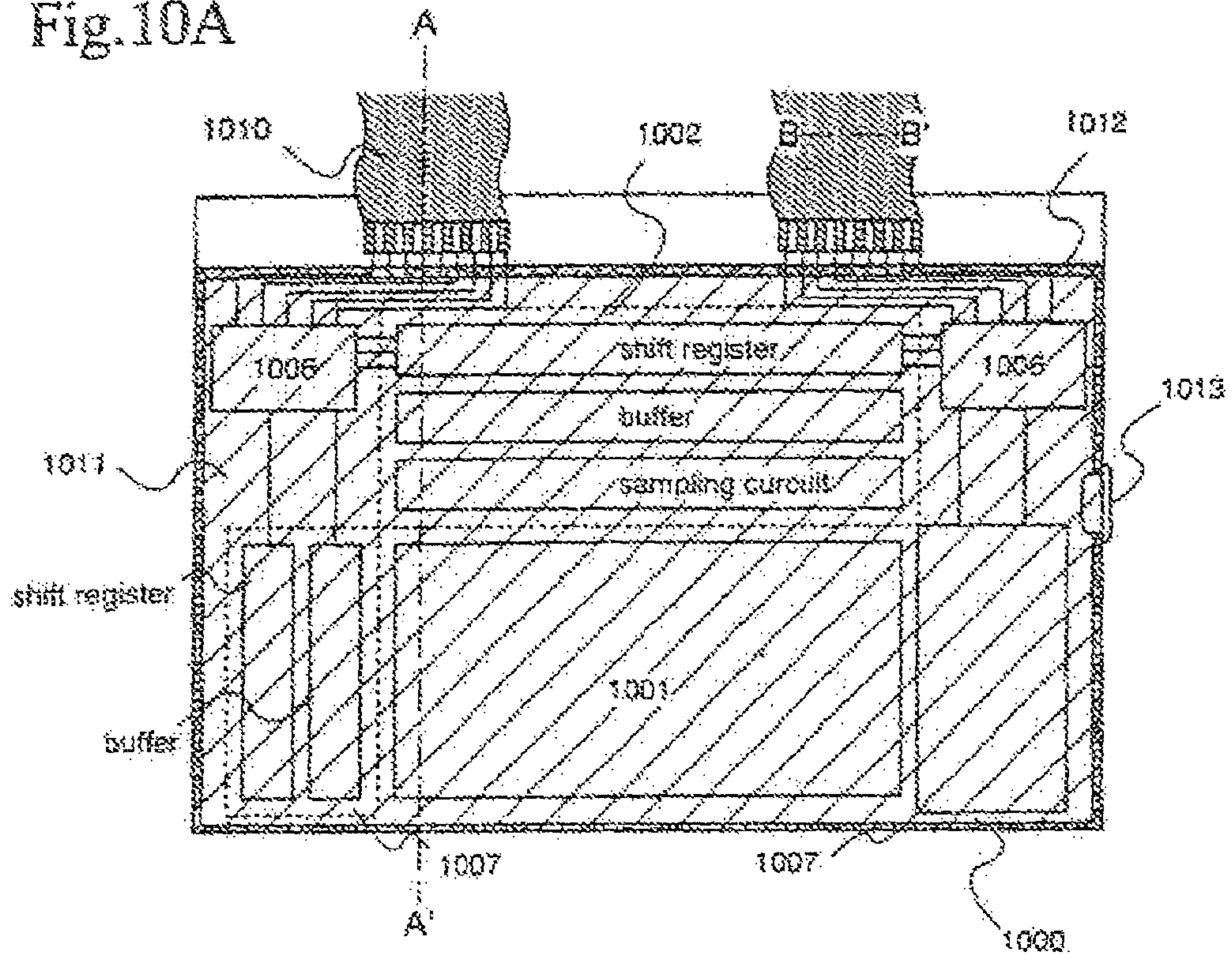

Fig. 10B

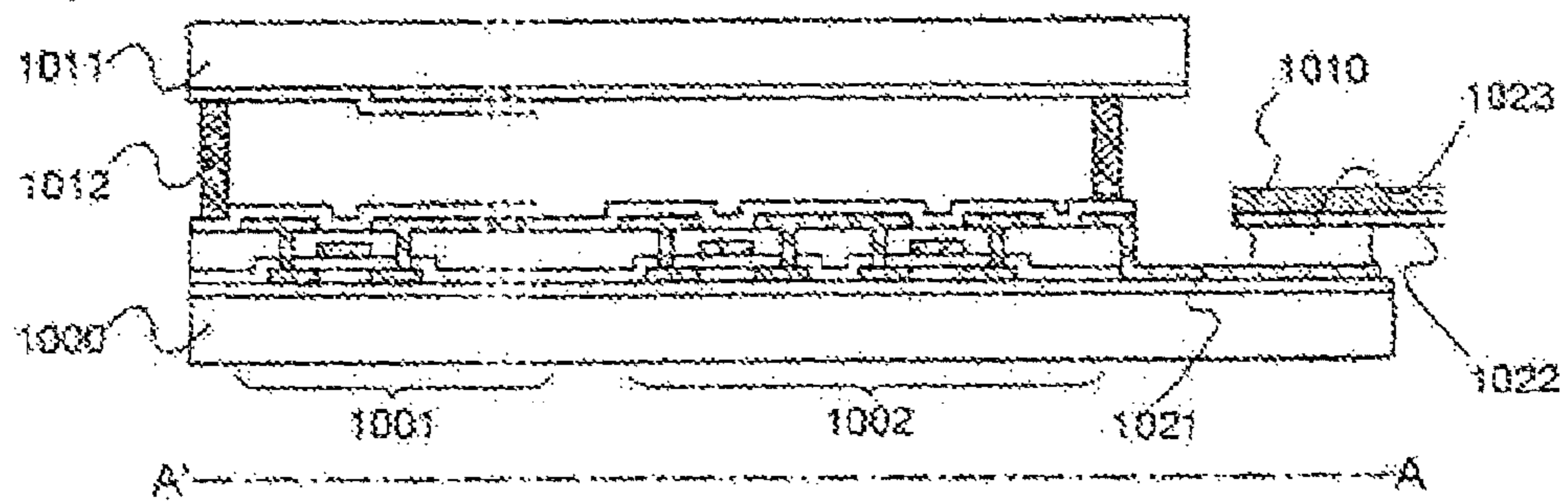
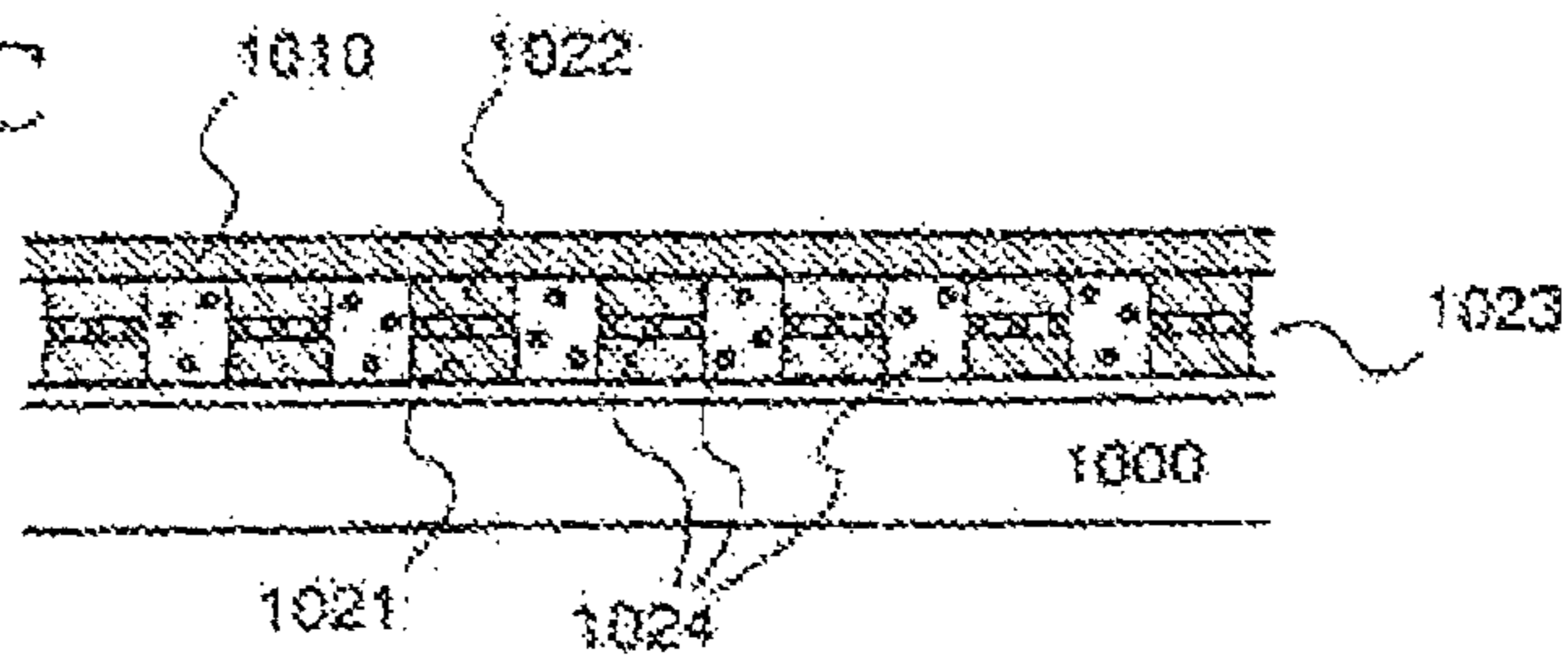

Fig. 10C



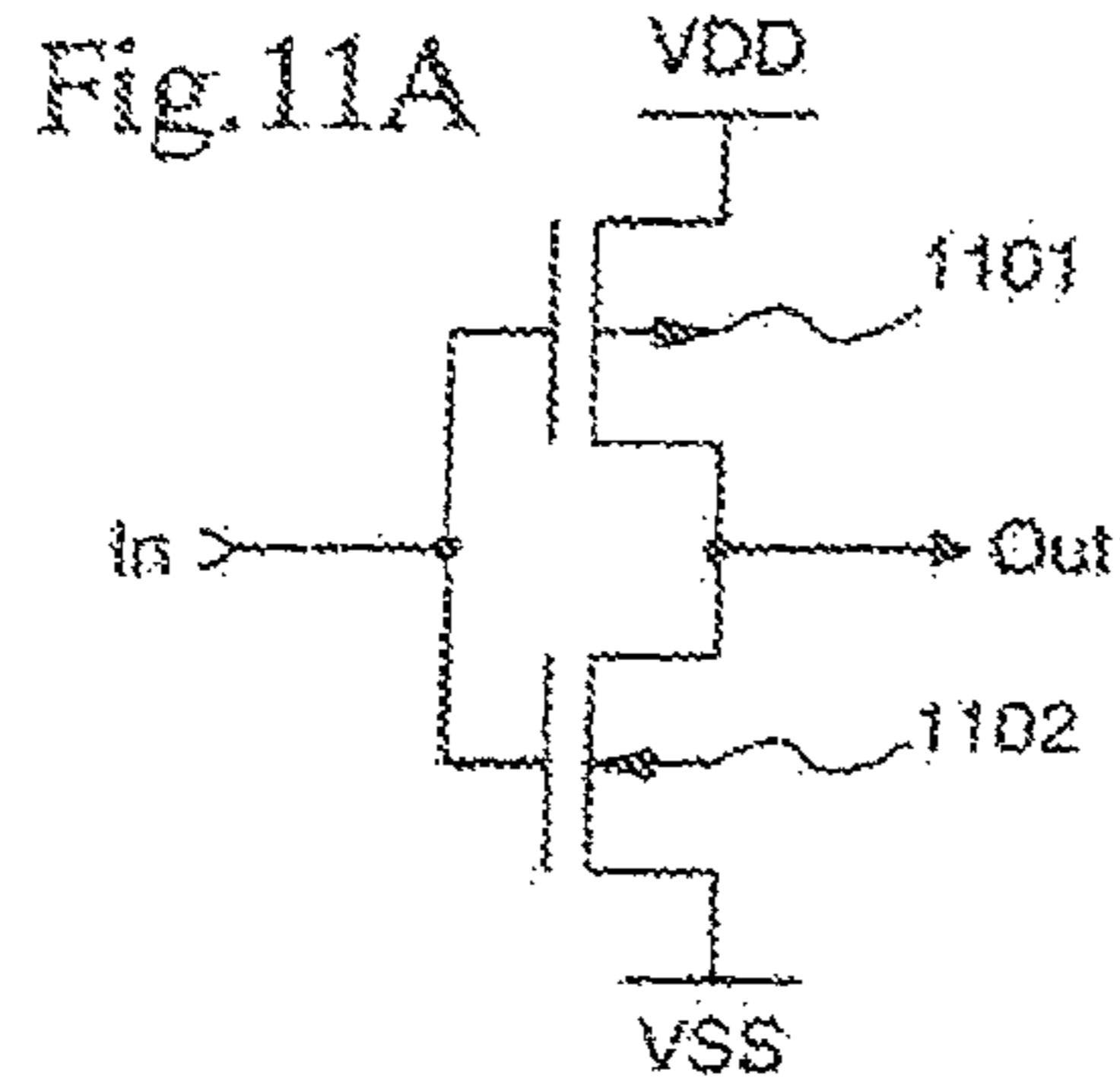

Fig. 11B

In	L	H
Out	H	L

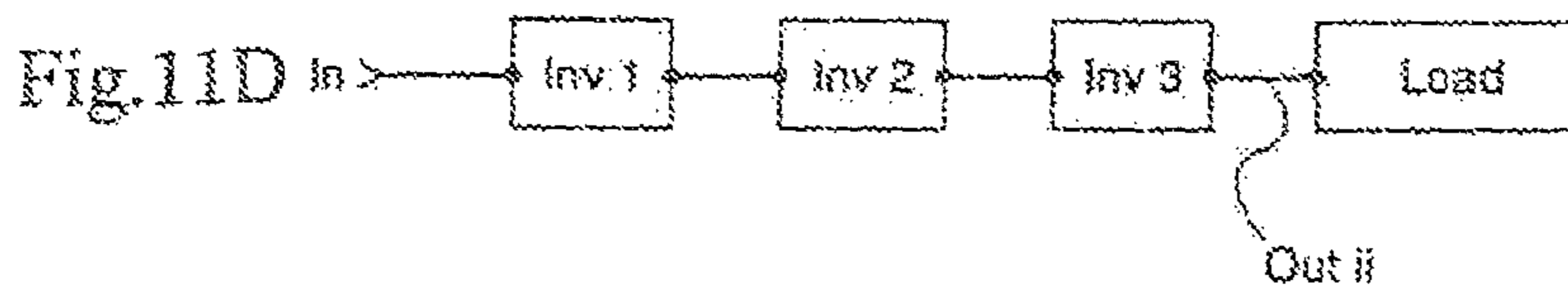
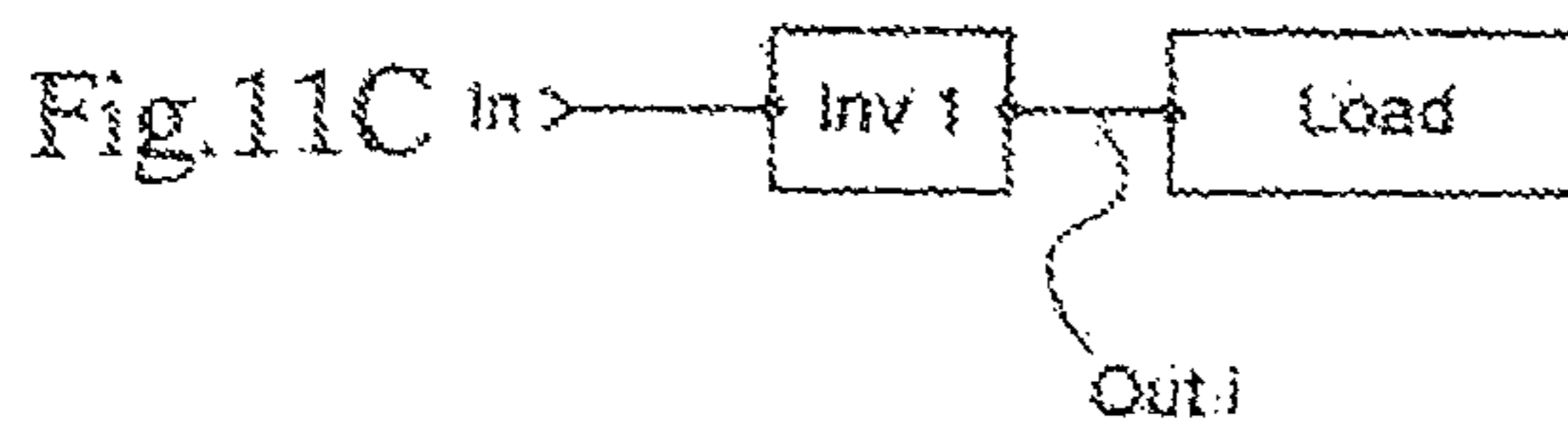

Fig. 11E

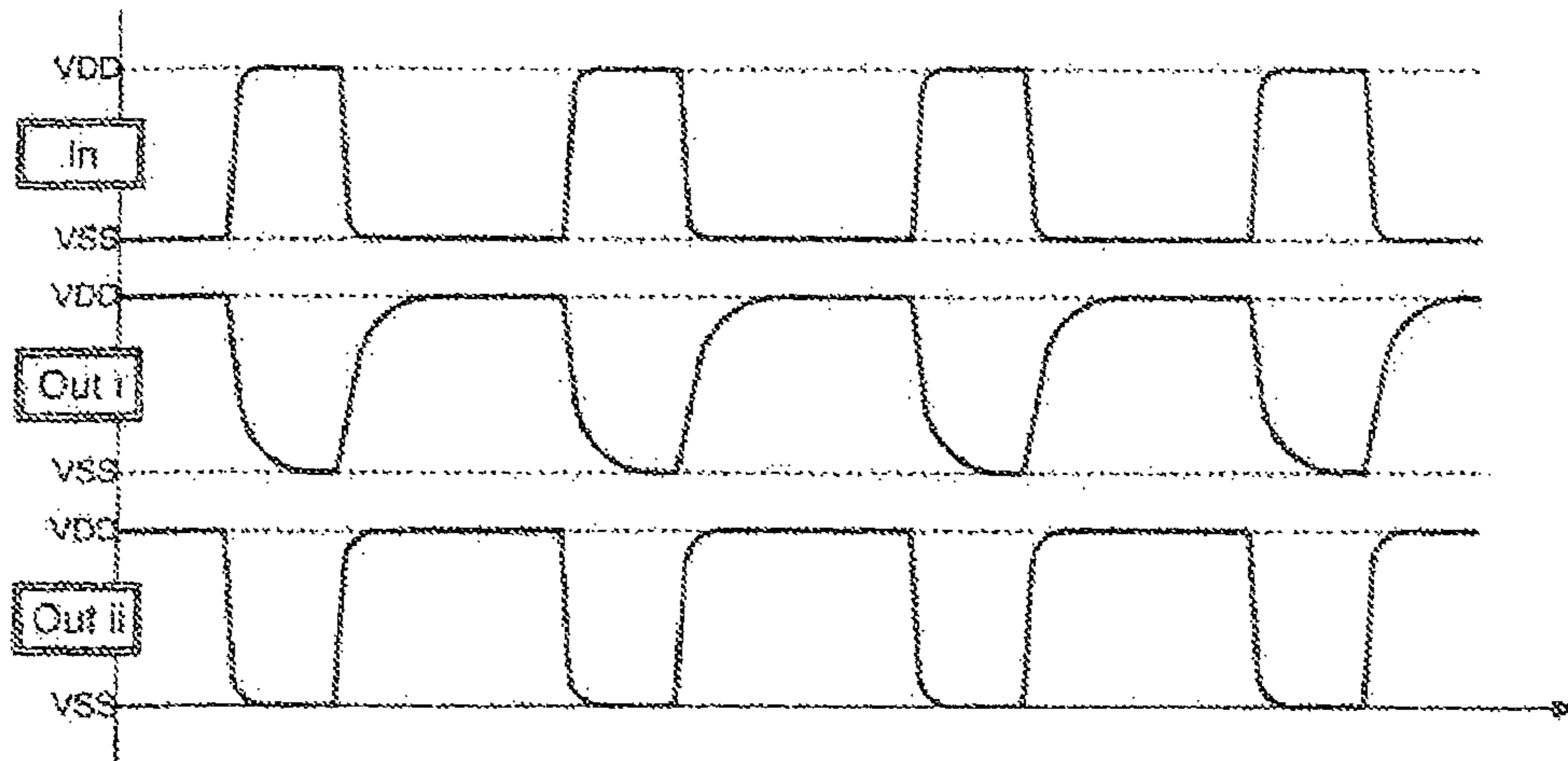

Fig.12A

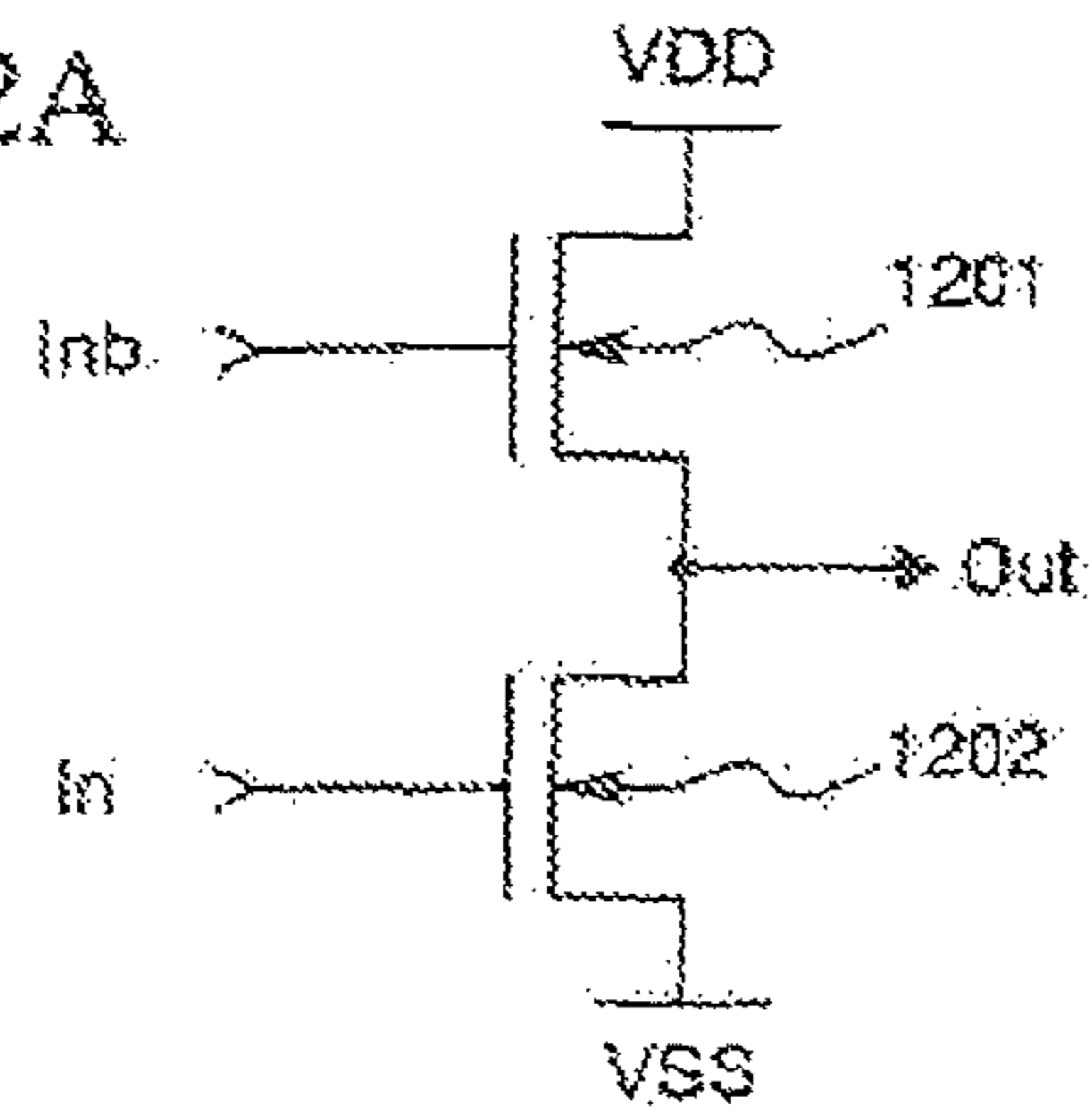

Fig.12B

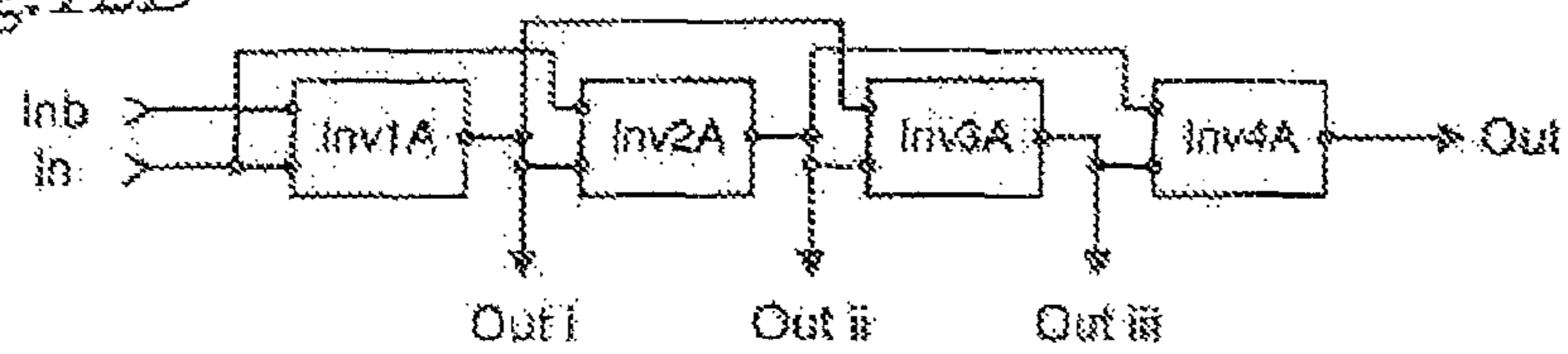

Fig.12C

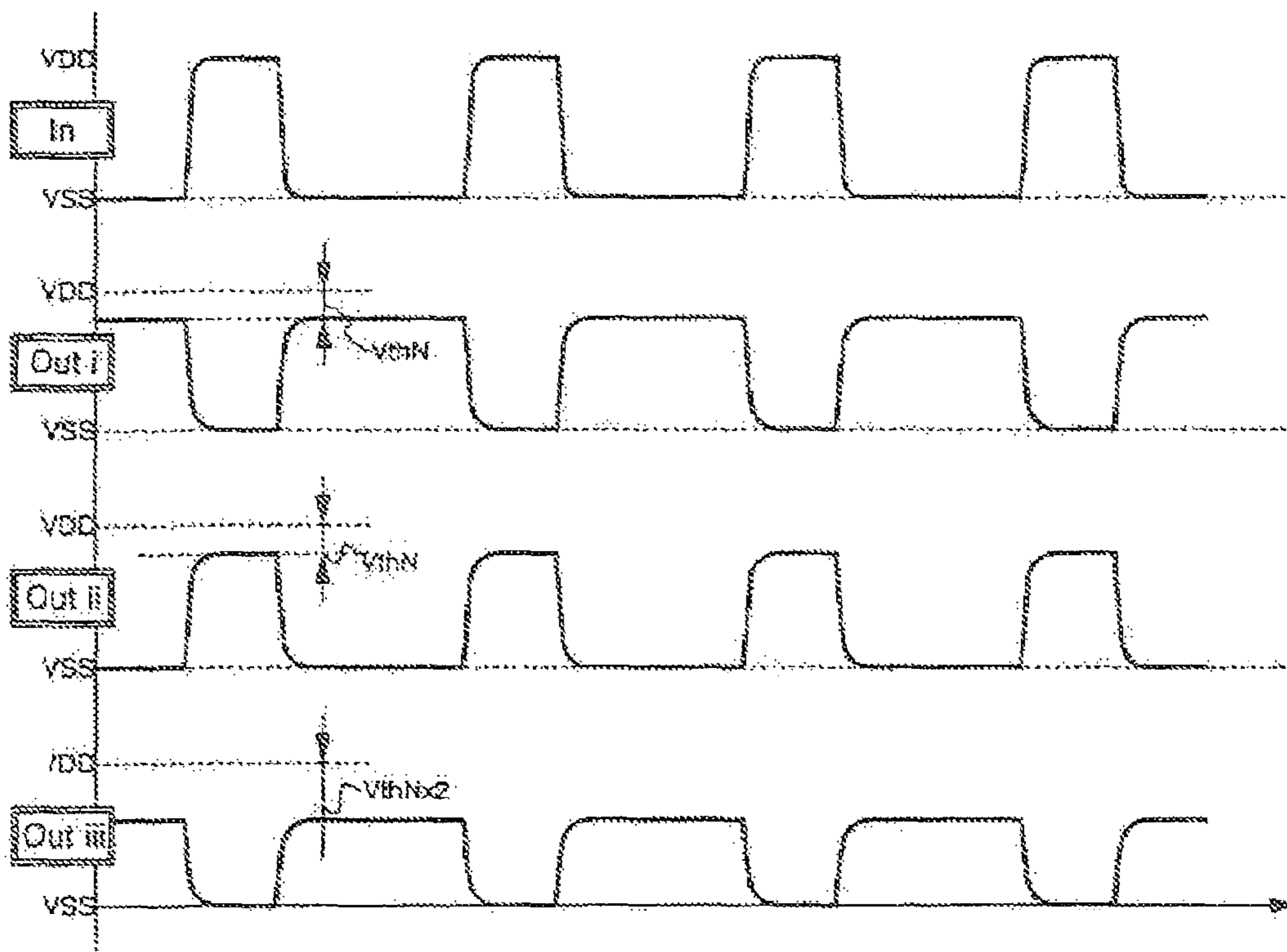

Fig. 13A

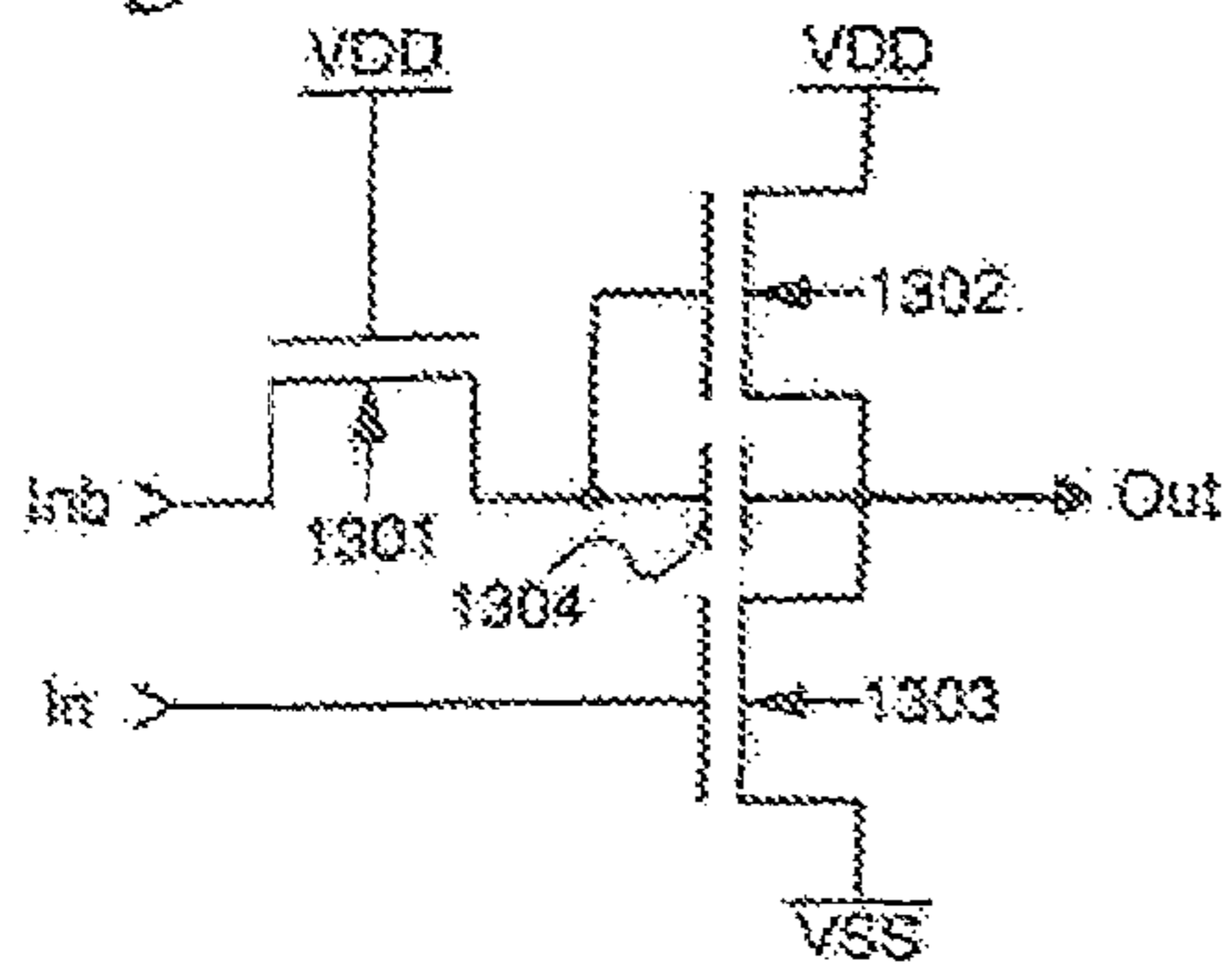

Fig. 13B

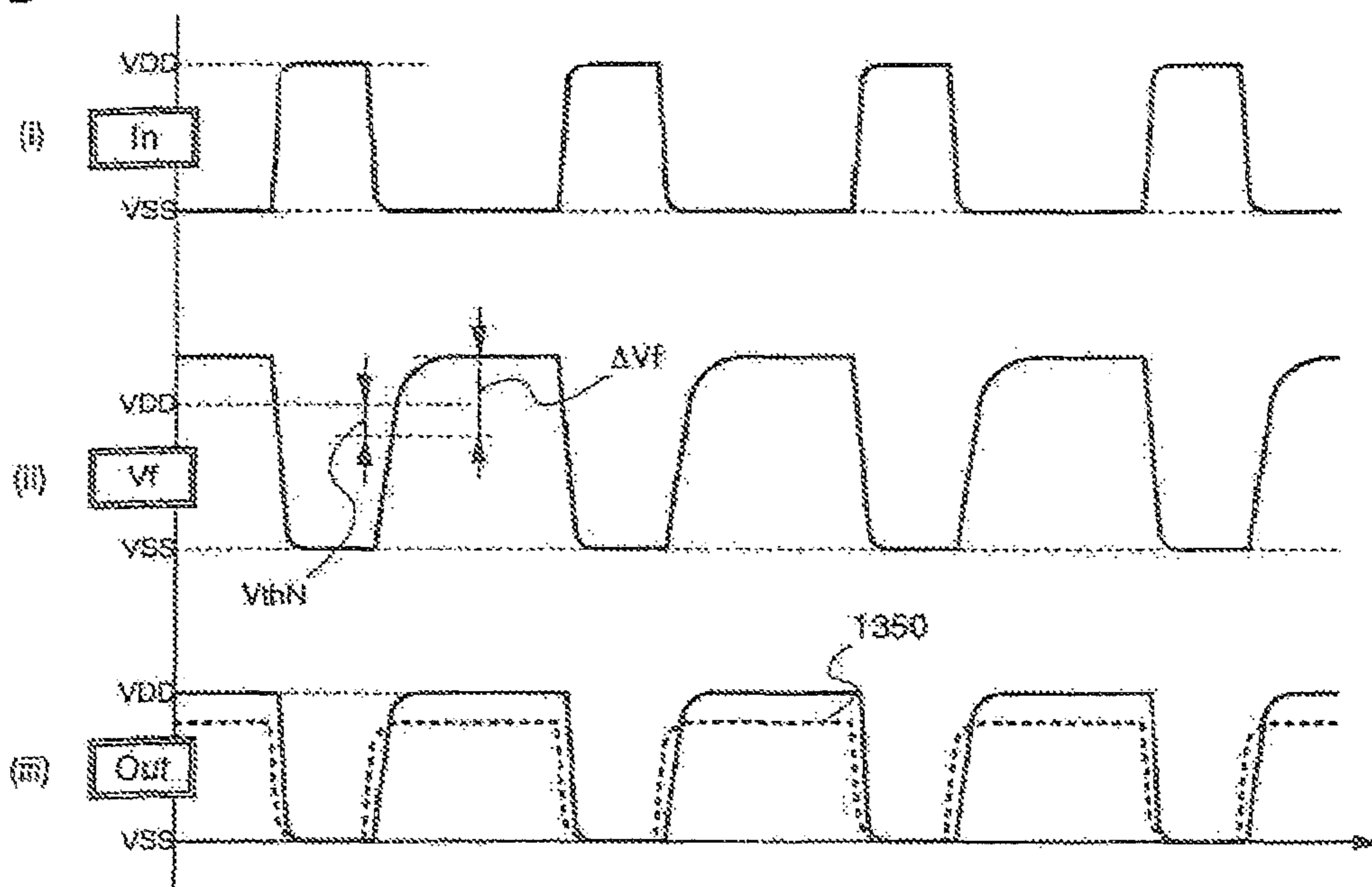

Fig. 14

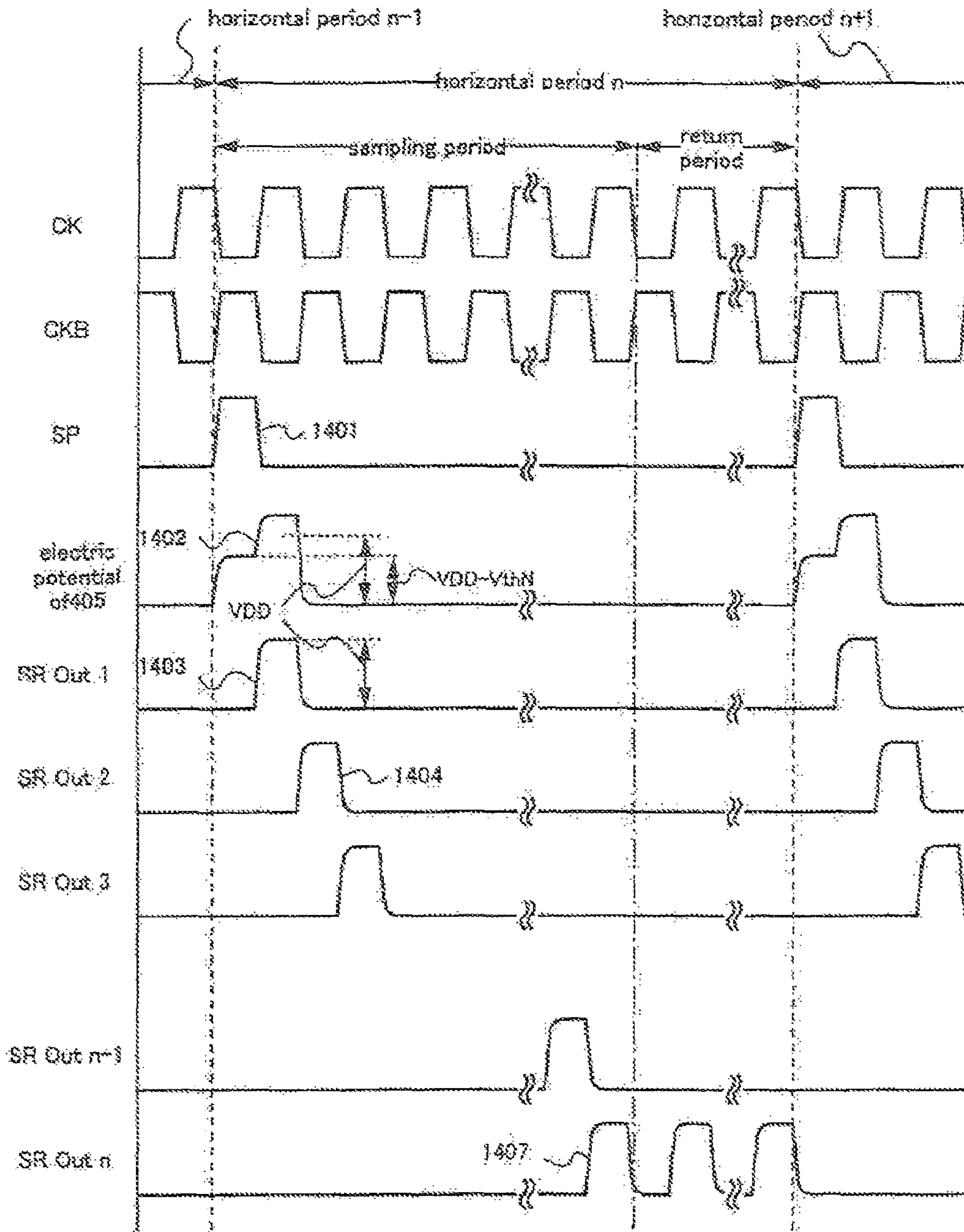

Fig. 15

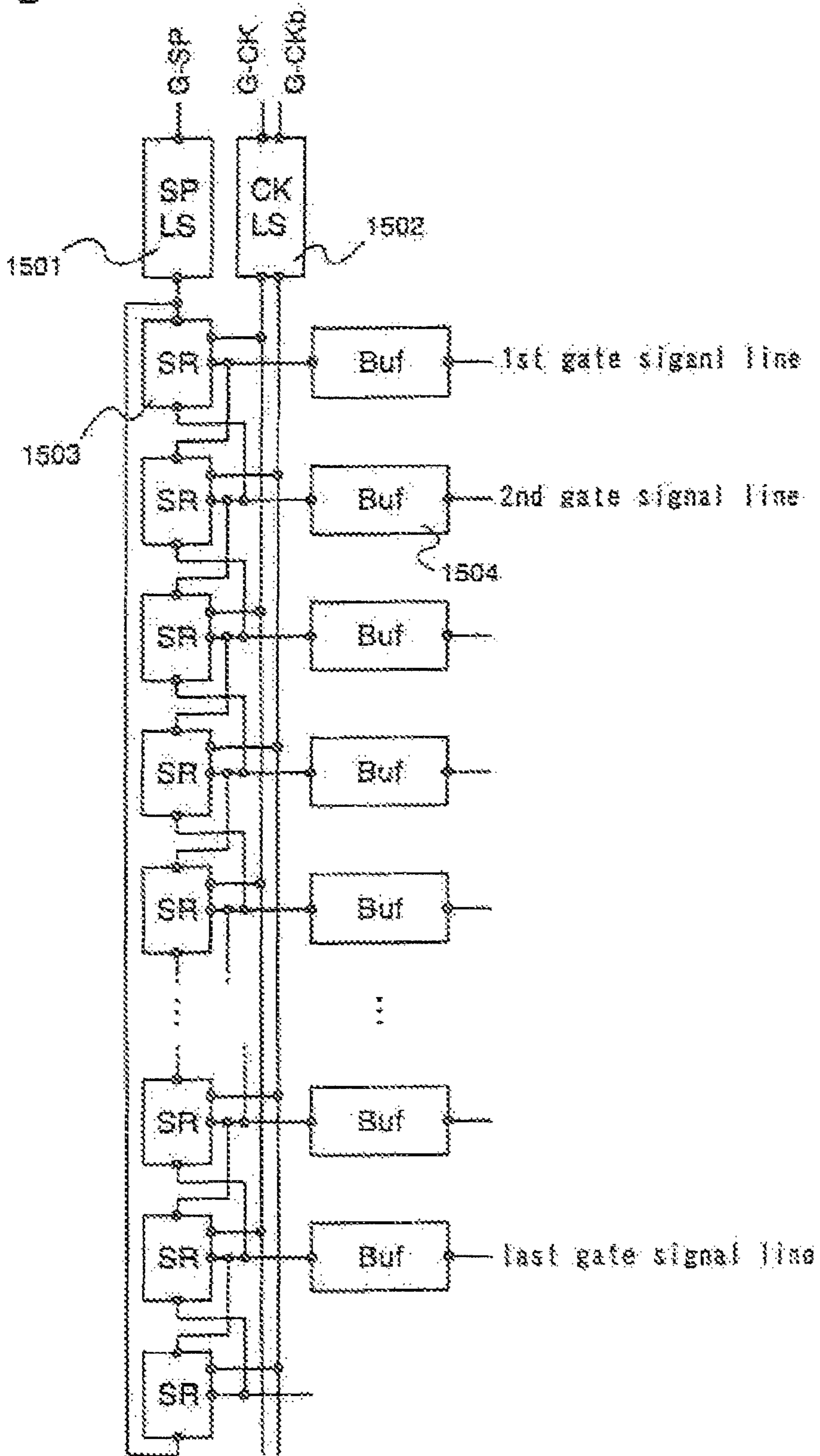

Fig. 16A

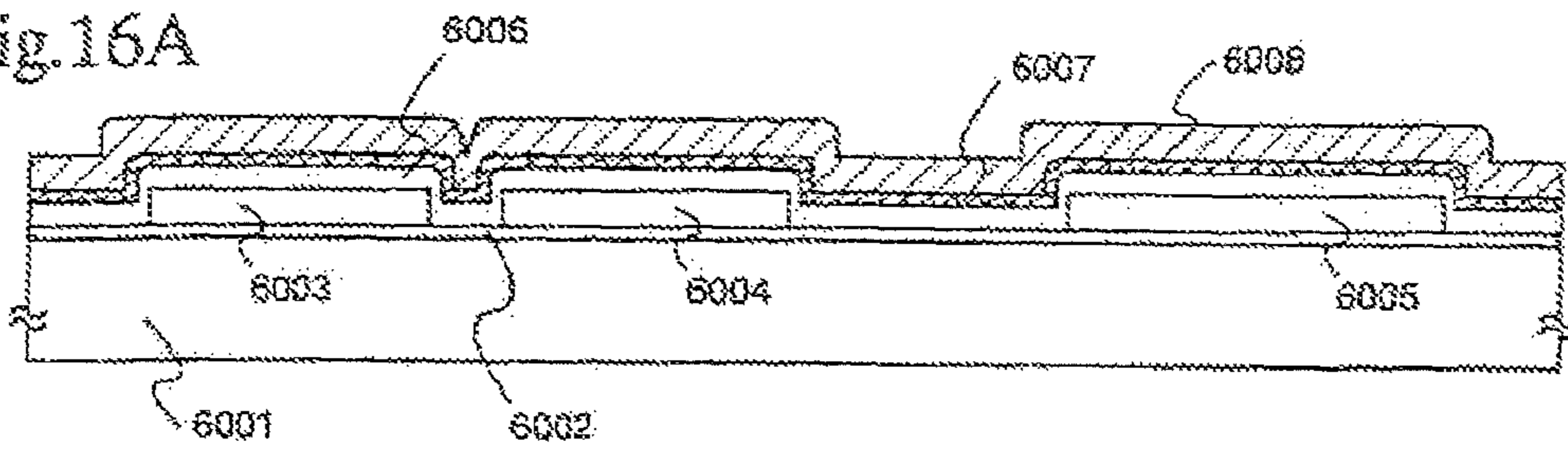

Fig. 16B

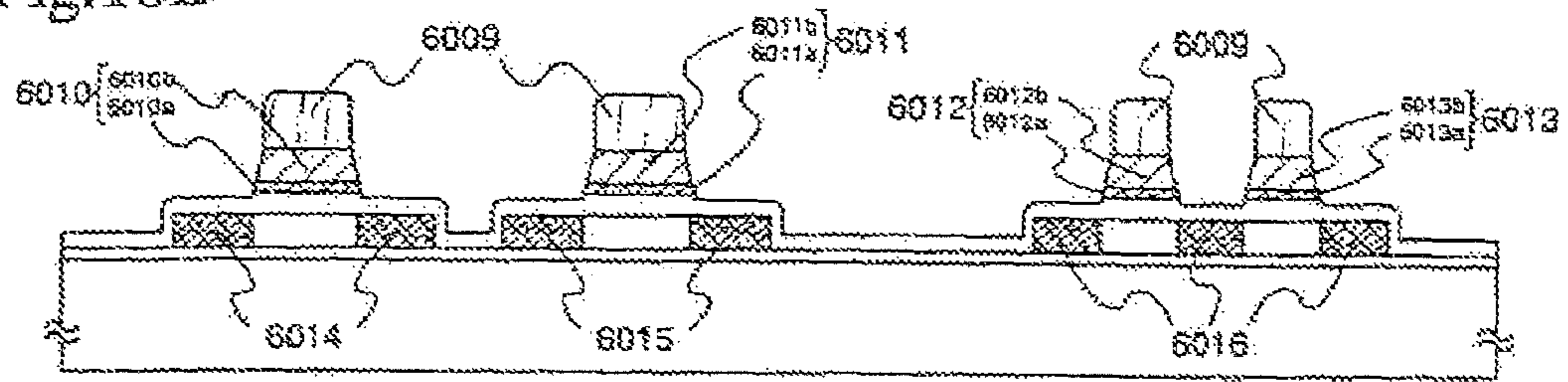

Fig. 16C

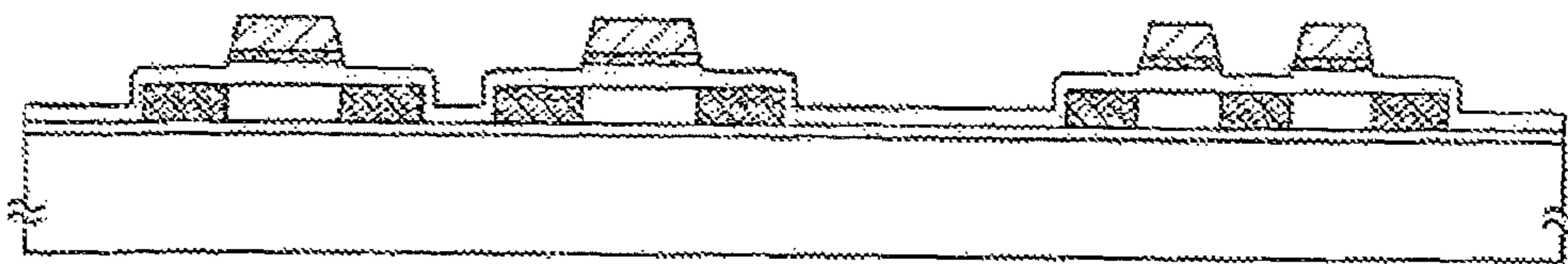

Fig.17A

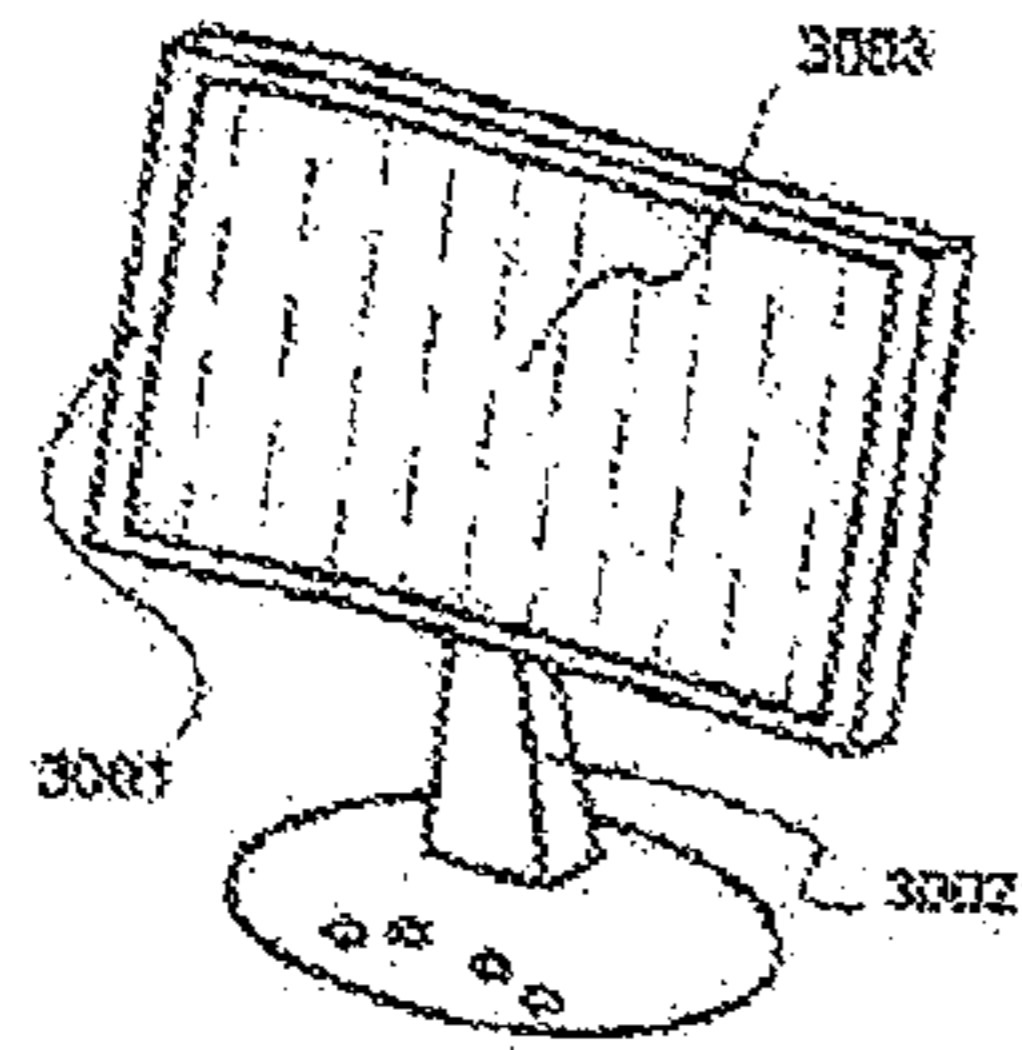

Fig.17B

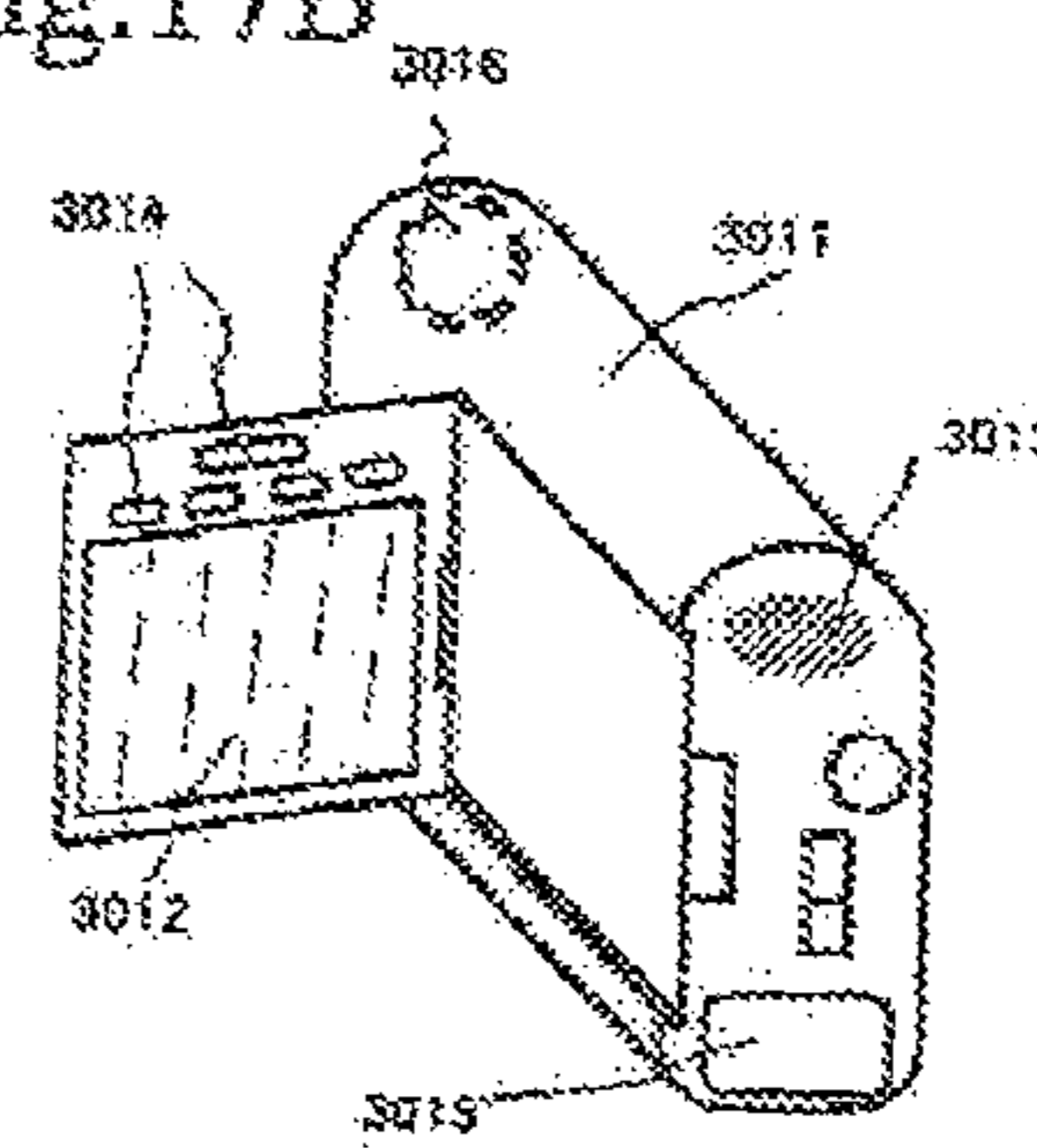

Fig.17C

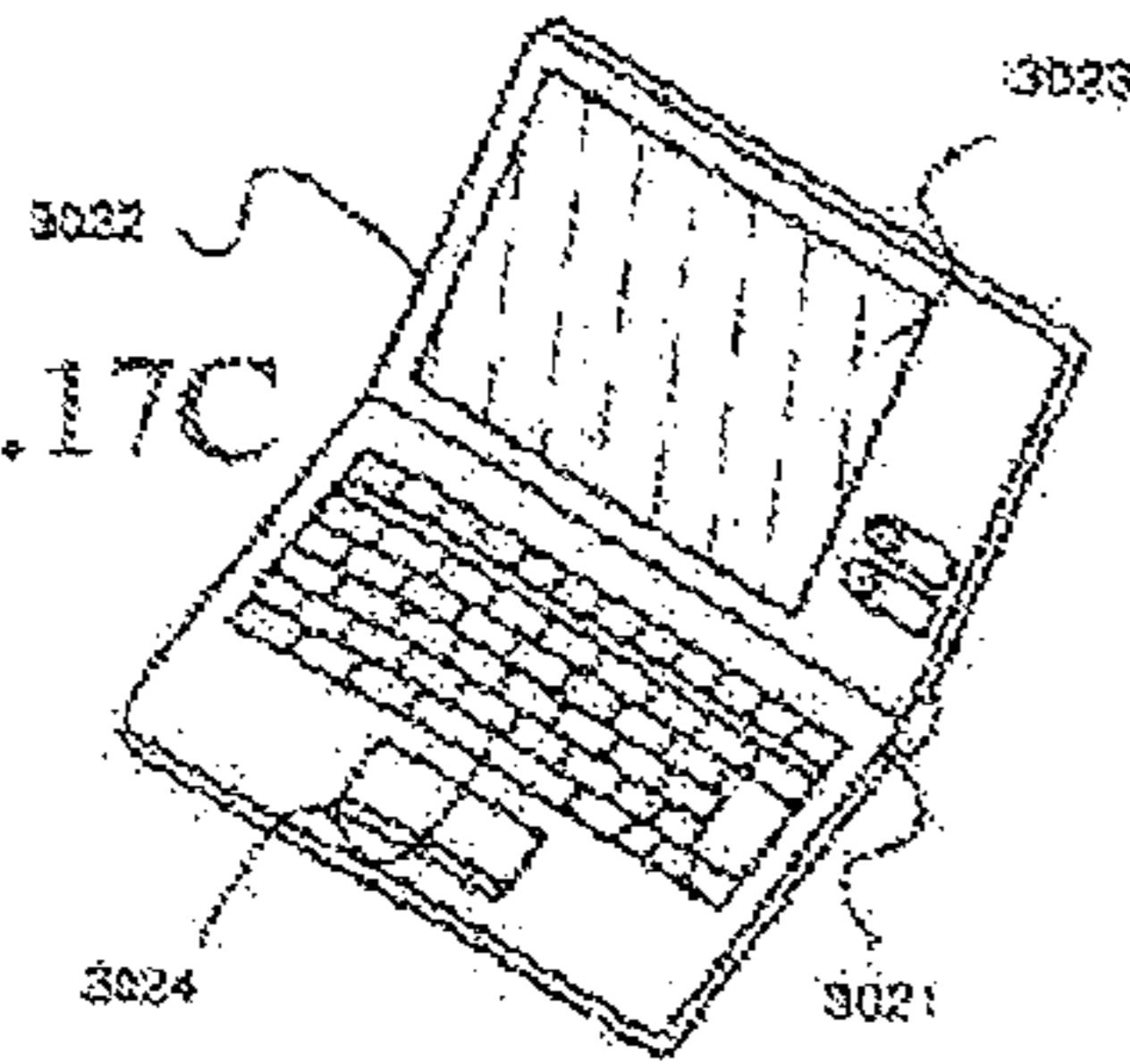

Fig.17D

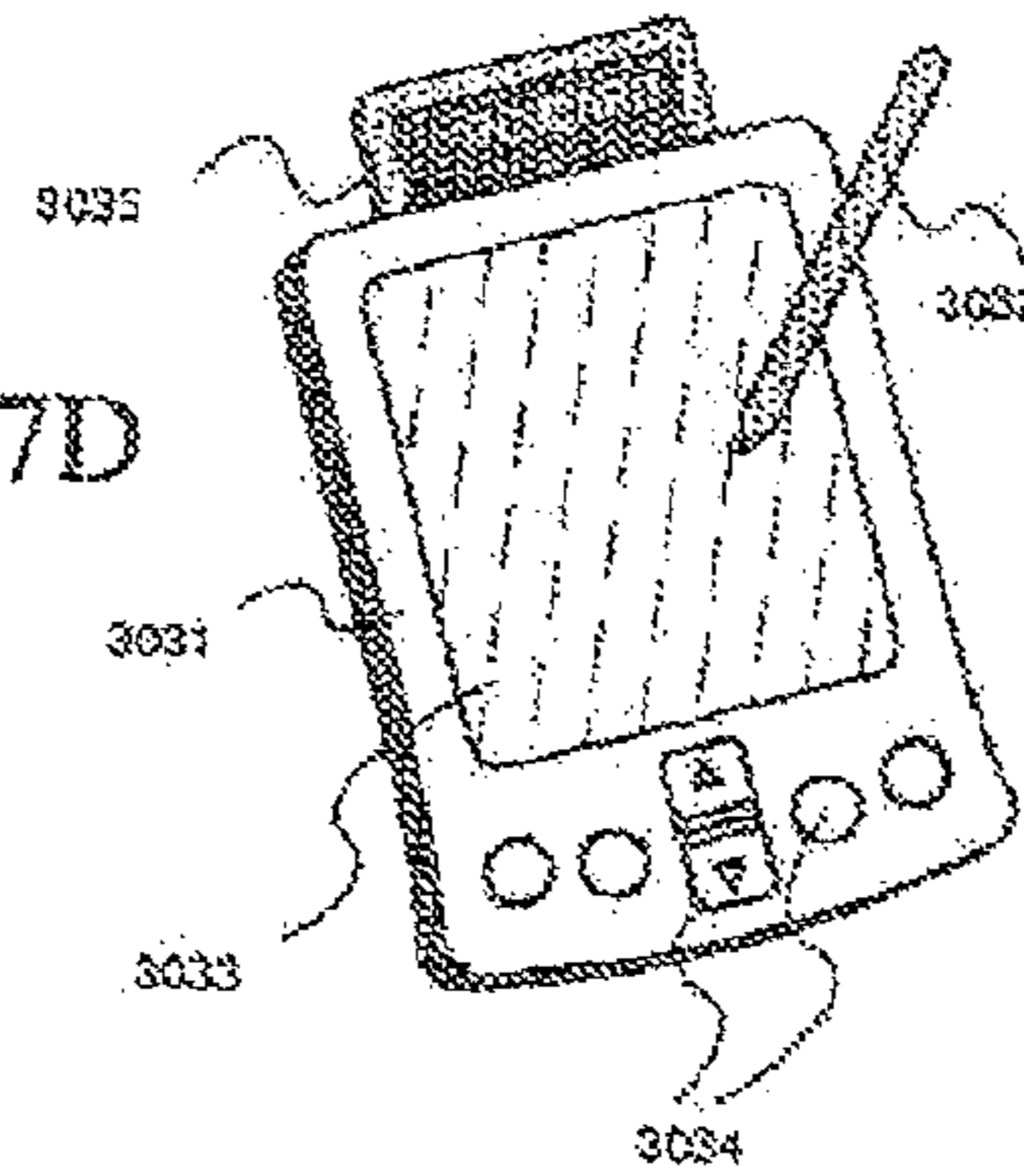

Fig.17E

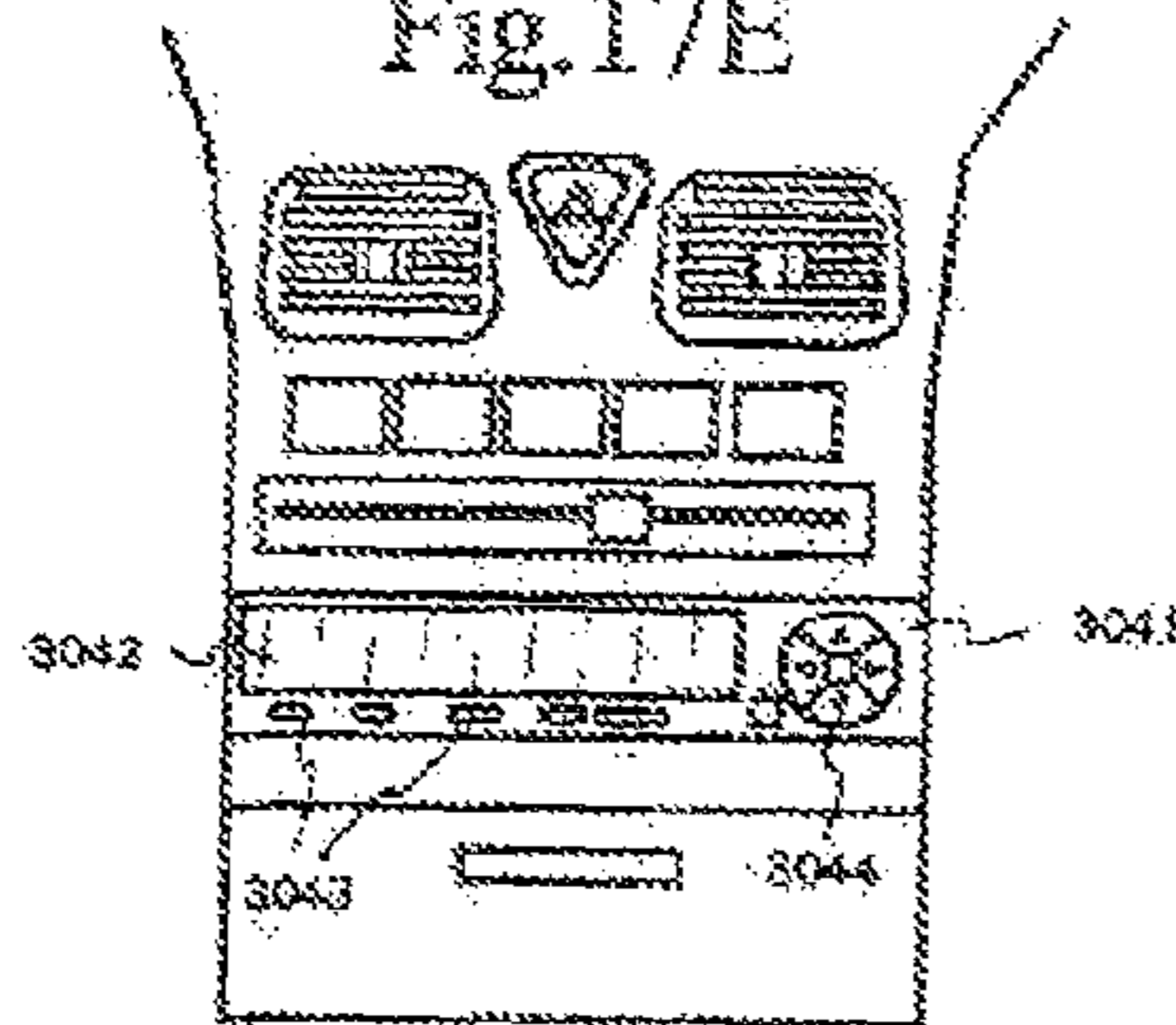

Fig.17F

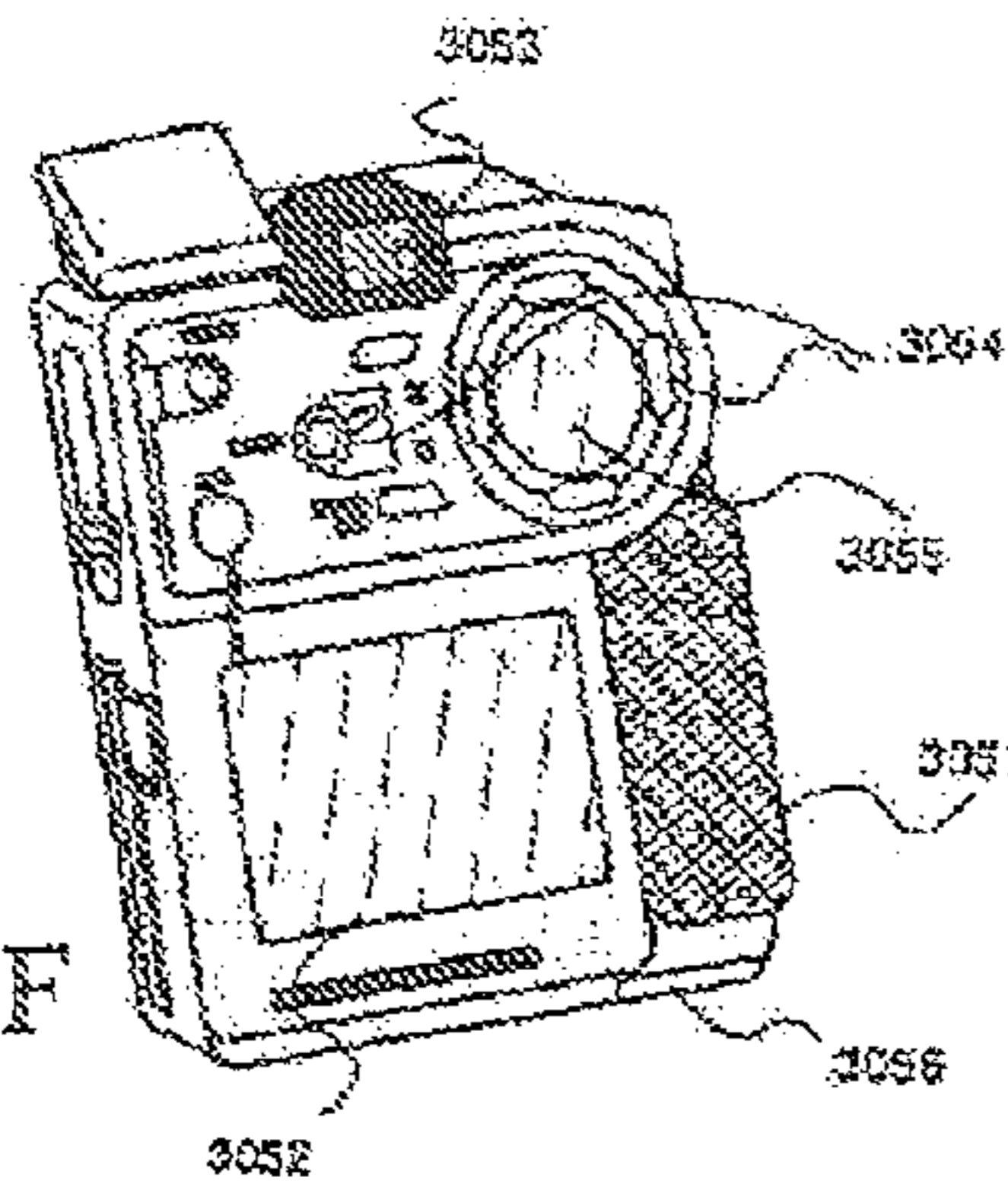
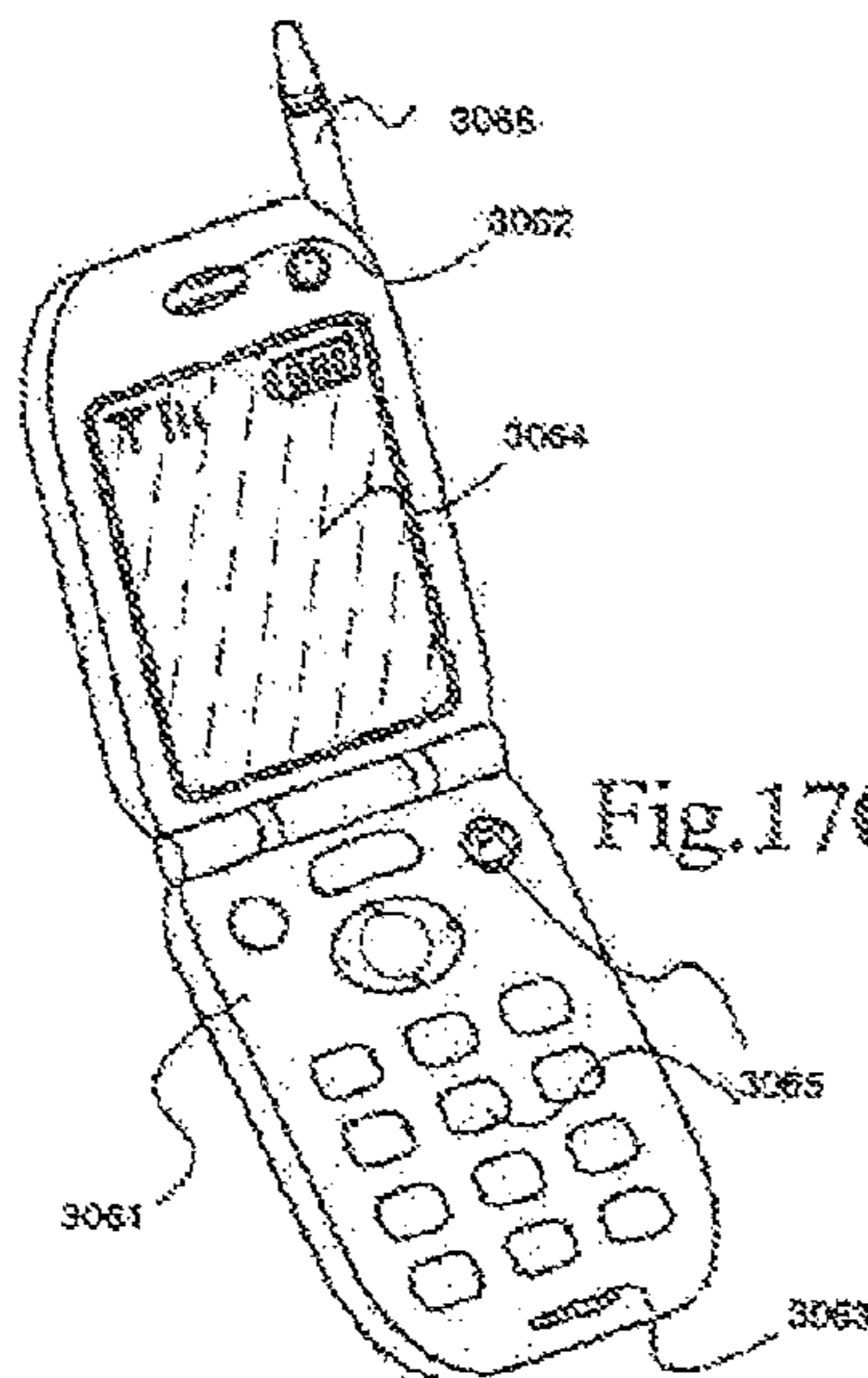

Fig.17G



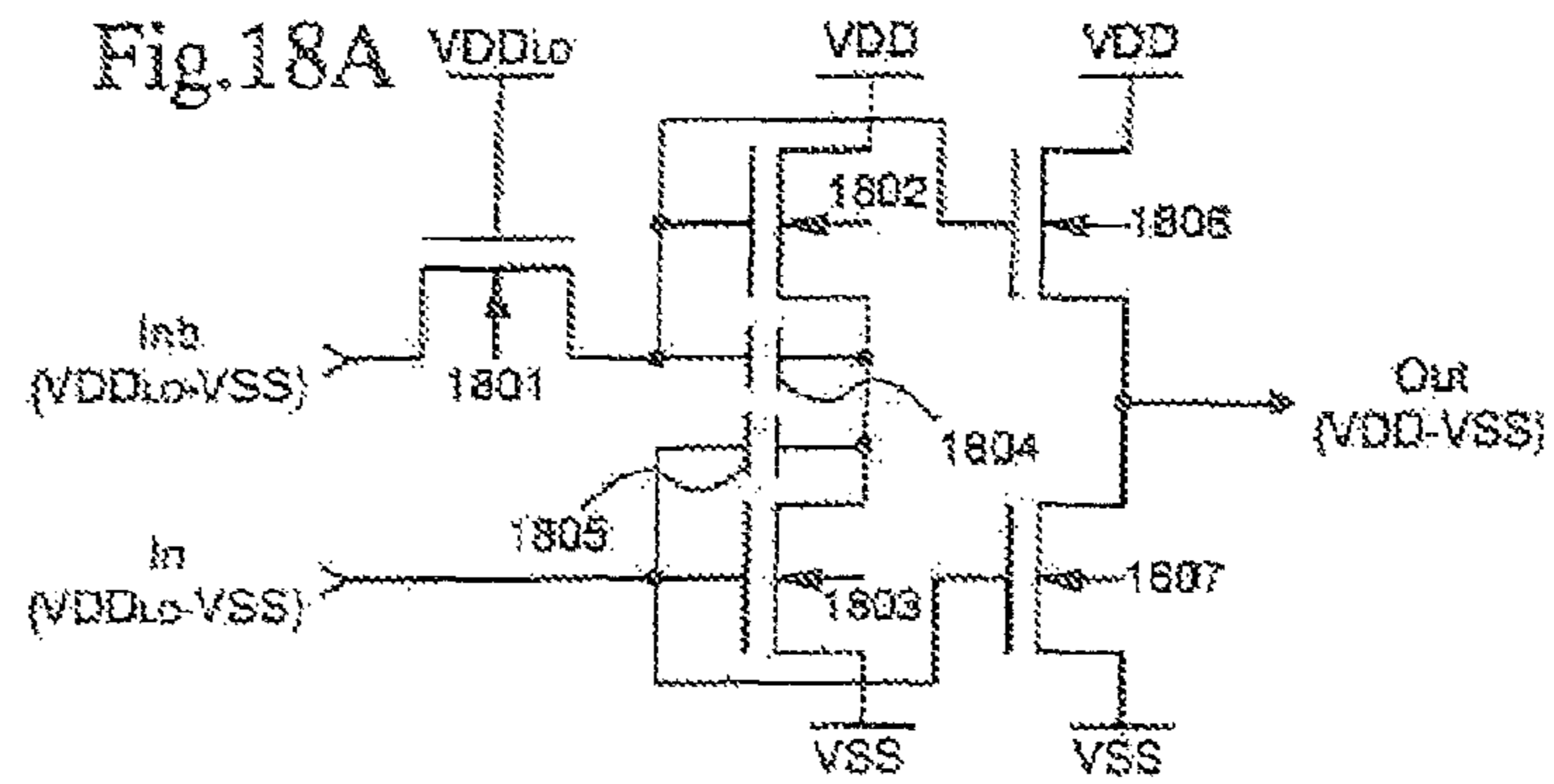

Fig.18B

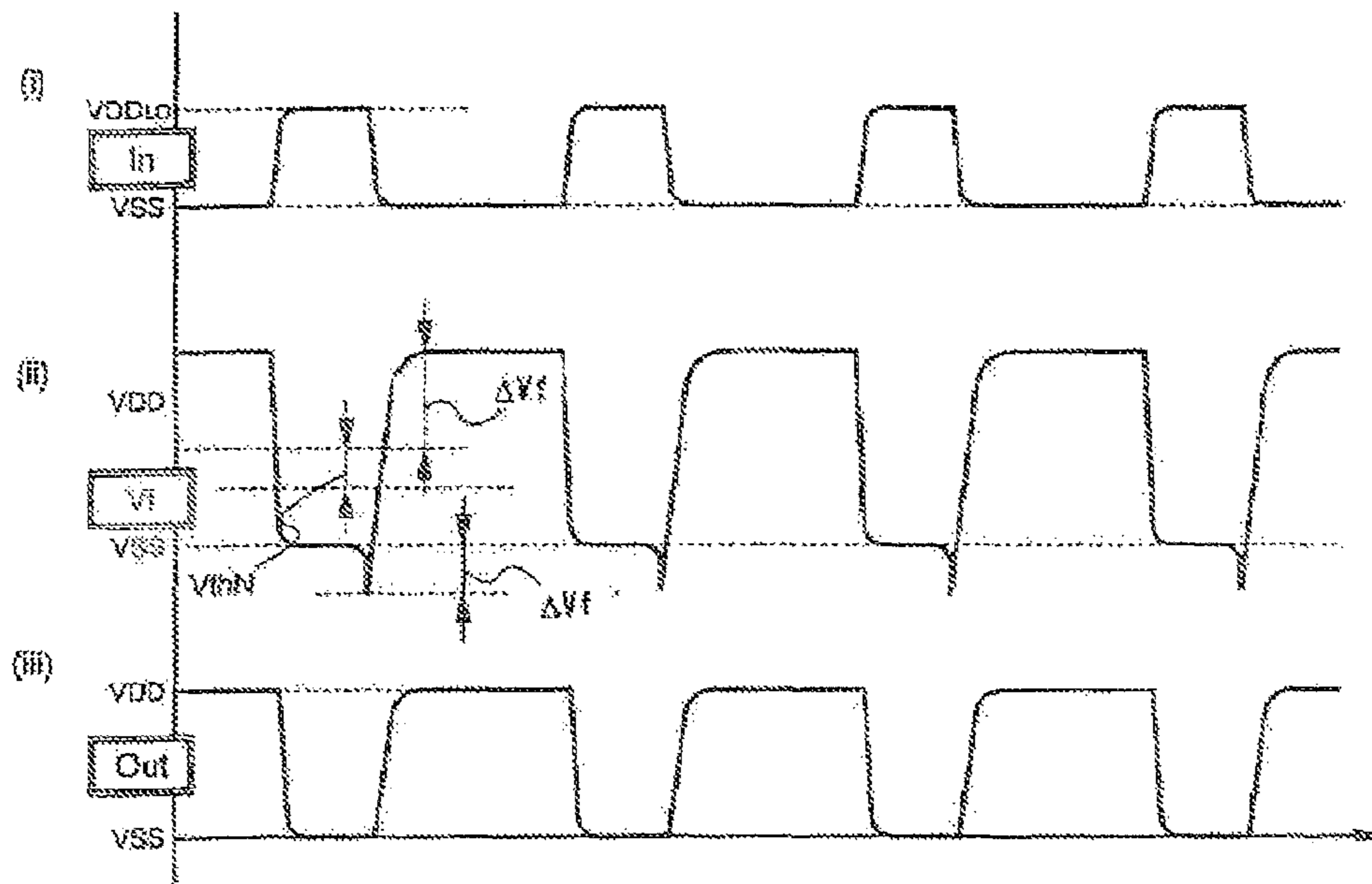

Fig.19A

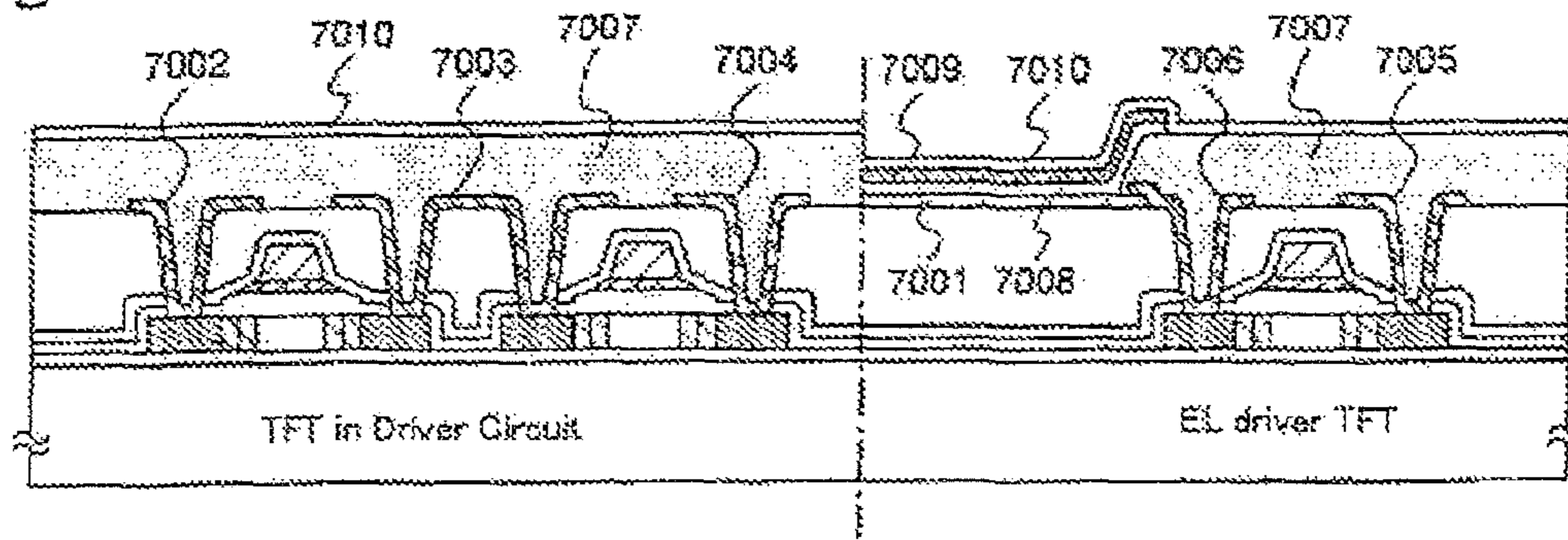

Fig.19B

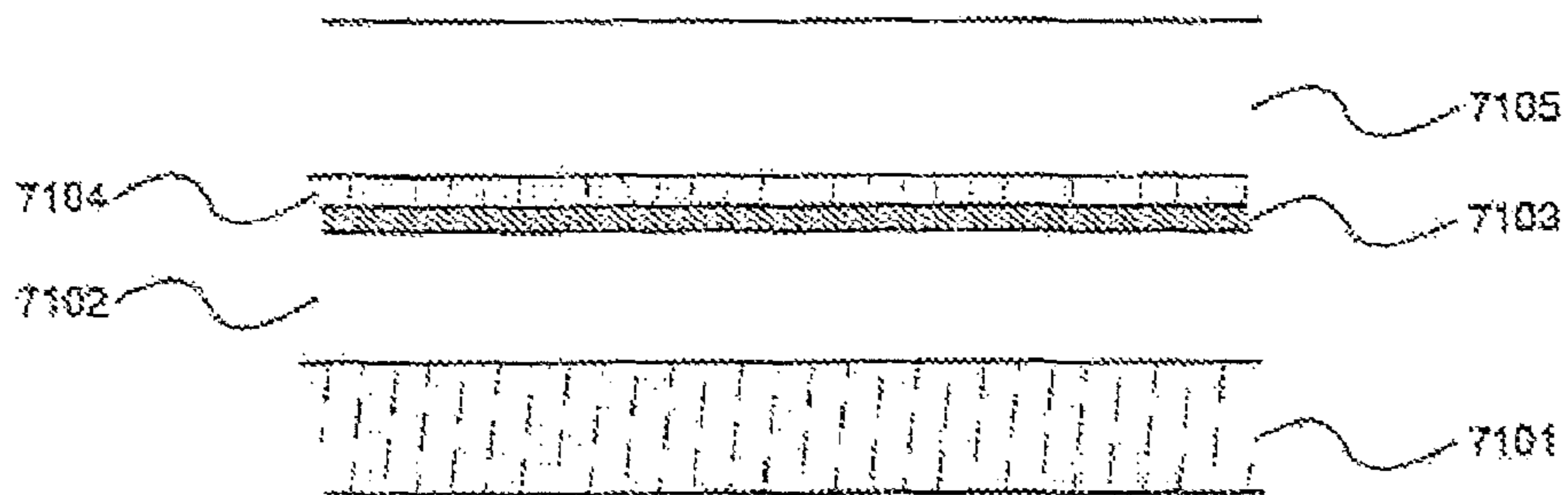

Fig.20A

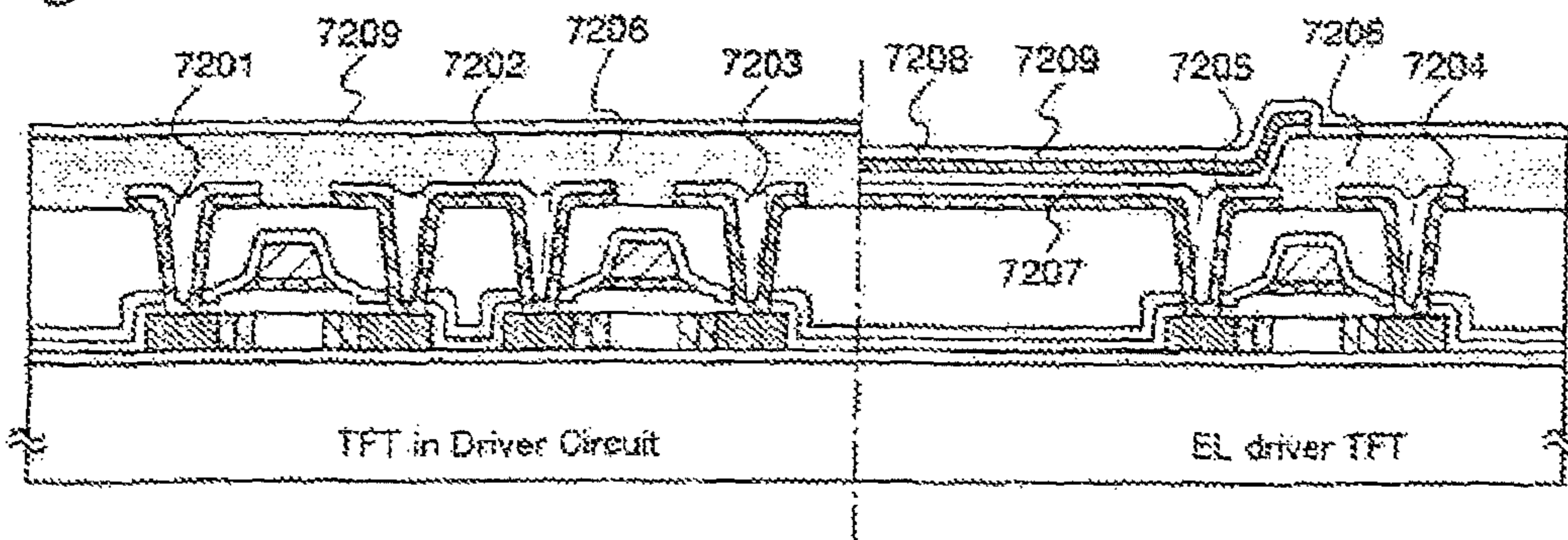

Fig.20B

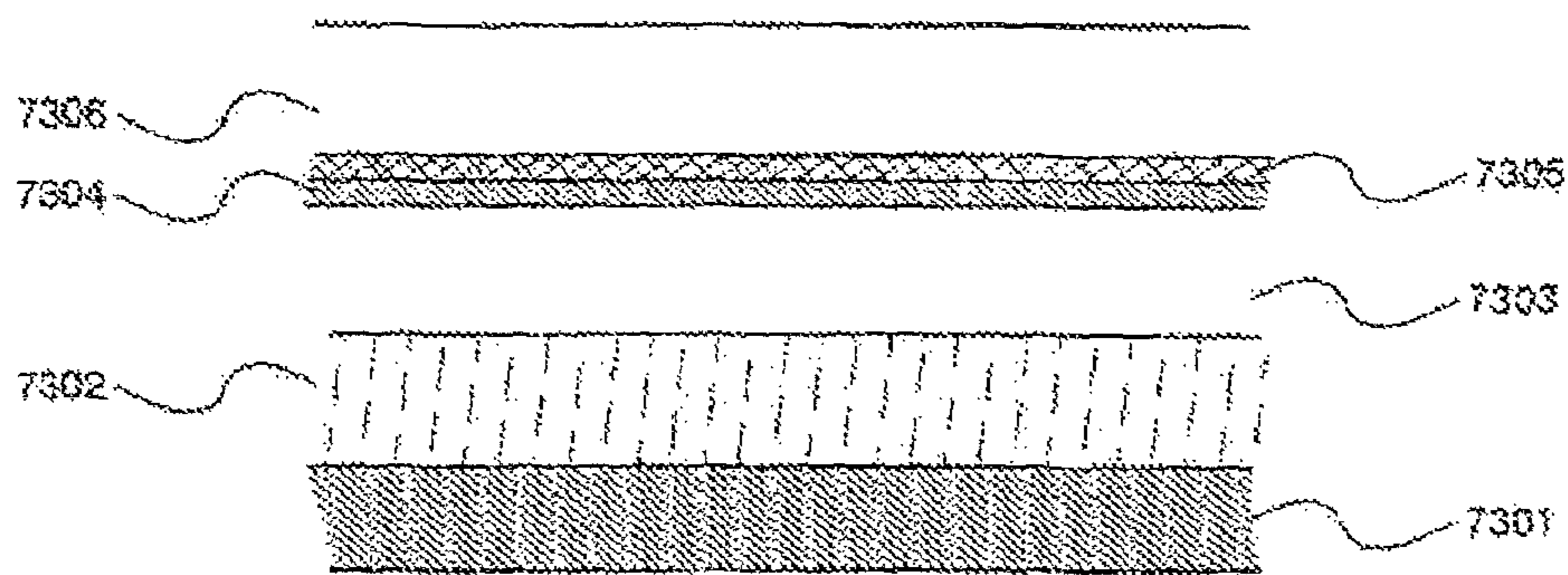

Fig. 21

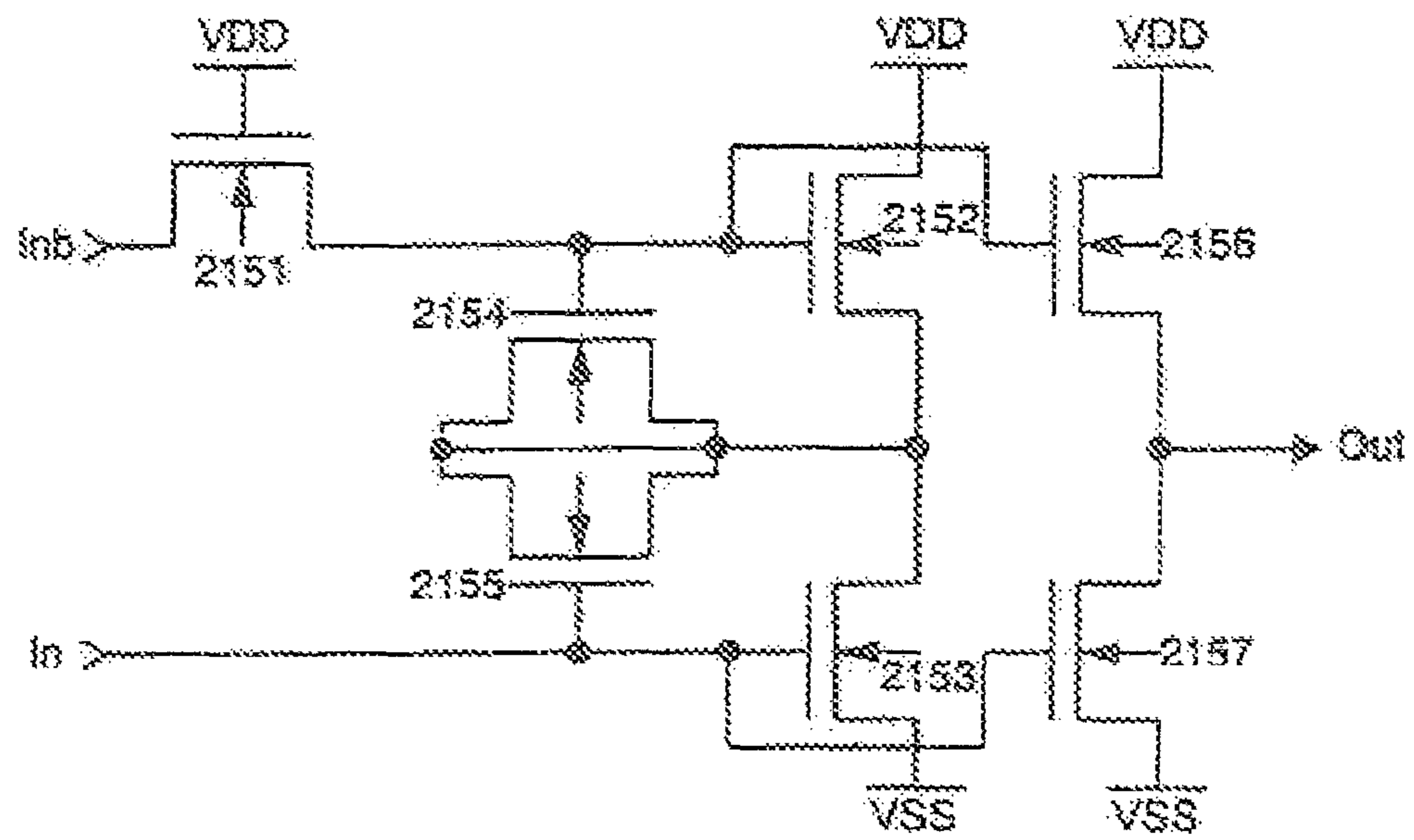

Fig.22A

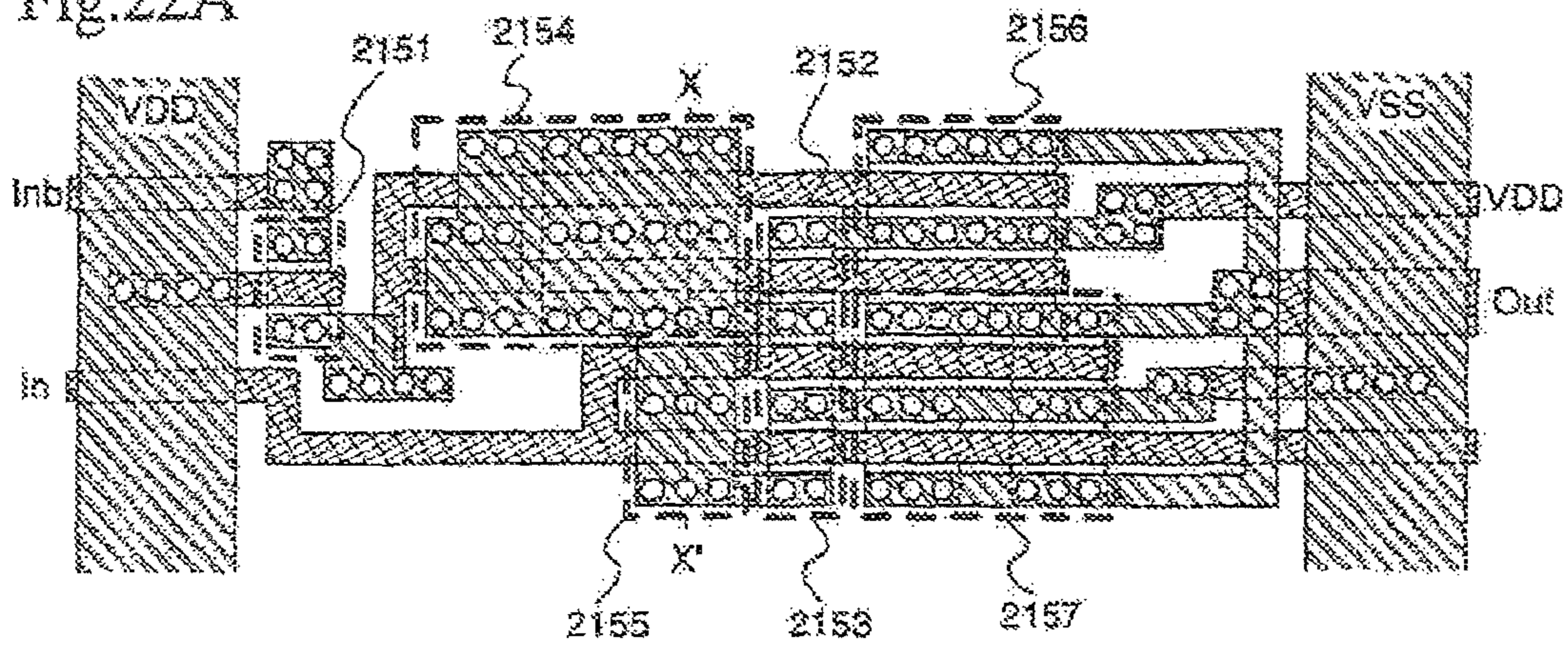

Fig.22B

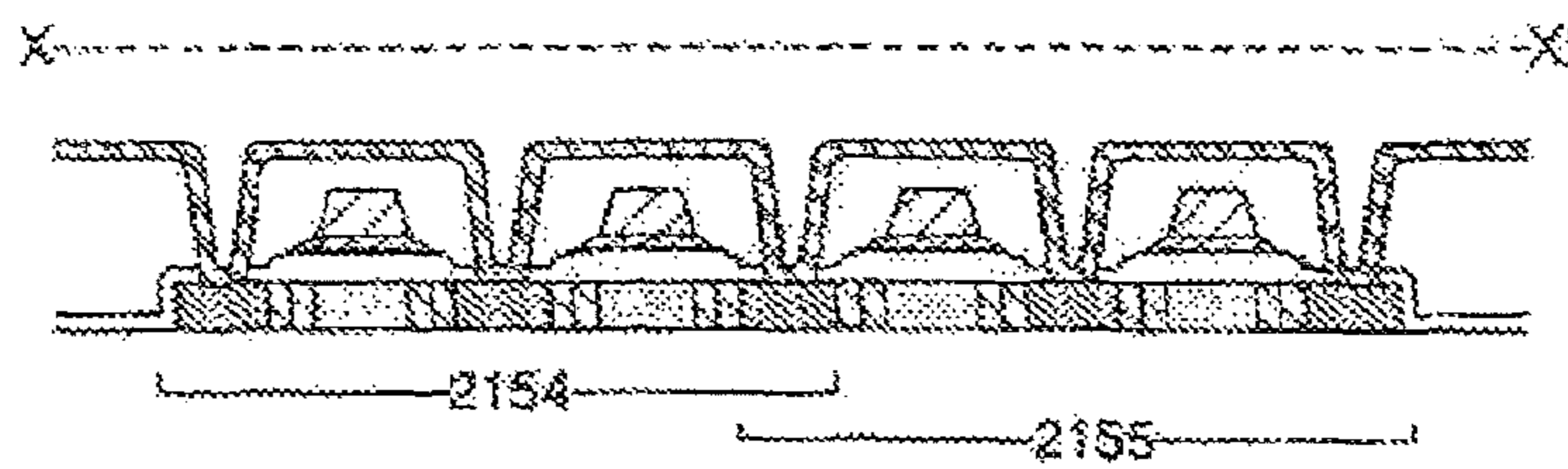
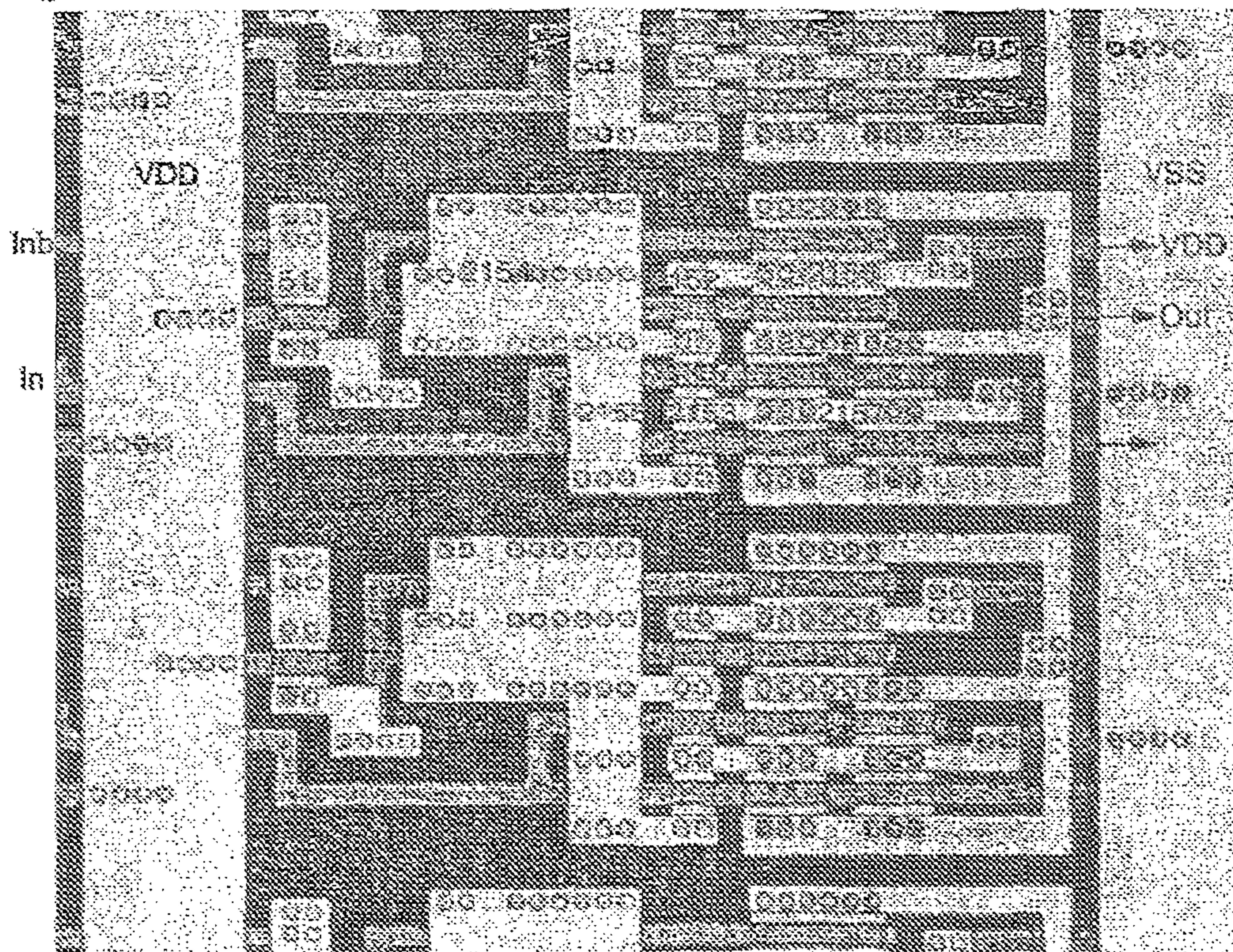

Fig.22C



SEMICONDUCTOR DEVICE

Matter enclosed in heavy brackets [] appears in the original patent but forms no part of this reissue specification; matter printed in italics indicates the additions made by reissue.

CROSS-REFERENCE TO RELATED APPLICATIONS

This application is a divisional reissue of U.S. application Ser. No. 12/369,914, filed Feb. 12, 2009, now U.S. Pat. No. Re. 43,401, which is a reissue application of U.S. application Ser. No. 11/463,356, filed Aug. 9, 2006, now U.S. Pat. No. 7,362,139, issued Apr. 22, 2008, which is a continuation of U.S. application Ser. No. 10/901,127, filed Jul. 29, 2004, now U.S. Pat. No. 7,091,749, issued Aug. 15, 2006, which is a continuation of U.S. application Ser. No. 10/202,861, filed Jul. 26, 2002, now U.S. Pat. No. 6,788,108, issued Sep. 7, 2004, and which claims the benefit of a foreign priority application filed in Japan as Serial No. 2001-229054 on Jul. 30, 2001. This application claims priority to each of these prior applications.

Notice: More than one reissue application has been filed for the reissue of U.S. Pat. No. 7,362,139. The reissue applications are the present application and application Ser. No. 12/369,914, all of which are divisional reissues of U.S. Pat. No. 7,362,139.

BACKGROUND OF THE INVENTION

1. Field of the Invention

The present invention relates to an inverter, buffer, and level shifter, and to a semiconductor device using them. Note that the term display device used within this specification includes a liquid crystal display device which employ liquid crystal elements in pixels, and a light emitting device which employ light emitting elements such as electroluminescence (EL) elements. The term semiconductor device indicates circuits that perform processing for inputting video signals into pixels disposed in the display device and displaying images. Pulse output circuits such as shift register, inverters, buffers, and level shifters, and amplification circuits such as amplifiers are included in the category of semiconductor devices.

2. Description of the Related Art

In recent years, display devices manufactured by forming semiconductor thin films on an insulator such as a glass substrate, in particular, active matrix display devices such as LCDs (liquid crystal displays) using thin film transistors (hereinafter referred to as TFTs), are being utilized in many manufactured products, and are spreading. The active matrix display devices using TFTs have from several hundred thousands to several million pixels arranged in a matrix shape, and display of images is performed by controlling the electric charge of each pixel with TFTs disposed in the respective pixels.

In addition, techniques related to polysilicon TFTs for TFTs have been developed recently, and a driver circuit using TFTs is formed in a peripheral region of a pixel portion on a substrate simultaneously with pixel TFTs structuring pixels. The techniques contribute greatly to making a device small size and to reducing electric power consumption, and accordingly, a display device has come to be indispensable for a portion such as a display portion of a mobile information terminal, which has remarkably been applied to the extensive fields in recent years.

In general, a CMOS circuit in which an n-channel TFT and a p-channel TFT are combined are used as a circuit for structuring semiconductor devices. A CMOS inverter is shown in FIG. 11A as one example of the CMOS circuit. A p-channel TFT 1101 and an n-channel TFT 1102 are combined, and an output signal is obtained by inverting the polarity of an input signal (see FIG. 11B).

Now, as shown in FIG. 11C, there is a state in which a certain load (Load) is attached to the later state of the CMOS inverter. If the load is excessive with respect to the size of the TFTs structuring the CMOS inverter at this point and a pulse is input from an input (In), there will be a case in which an output pulse, namely an output (Out i) of an inverter (Inv1) in FIG. 11C, is greatly dulled in both rise and fall of the pulse, compared to the waveform of the input signal, as shown in FIG. 11E. This is because the CMOS itself inverter does not have the capability of supplying a sufficient amount of electric charge for driving the load.

There normally is lot of weight given to low electric power consumption with semiconductor devices, and logical circuits are structured using relatively small size TFTs. On the other hand, display regions are becoming larger in size, and in addition, the number of pixels is increasing. The load due to the pixels is therefore large. As stated above, pulses are not output normally if a large load is present in the later stage of an inverter with a small driving capability.

A buffer is normally formed between a driver circuit portion and a pixel portion. Typically, a plurality of inverter stages are disposed in series as shown in FIG. 11D, and driving of the final load can be performed without problem by driving the inverters that are gradually increased in size. Compared to the structure of FIG. 11C, the waveform of an output (Out ii) of a buffer in the final stage (Inv4) is not greatly dulled and thus is output as a normal pulse, and the load in the later stage can be driven.

Display devices have come to be employed in the display portion of many types of electronic devices in recent years, and there is steady expansion in the number of fields in which display devices are used. Display devices are recently being actively employed even in relatively low cost electronic equipment, and therefore further cost reductions are desirable.

A multiple-layer structure is formed for a display device by repeatedly performing processes of film formation, exposure to light using a photomask, and etching. The extreme complexity of the processes therefore invites an increase in manufacturing costs. In addition, in the case in which the driver circuit and the pixel portion are formed integrally on the substrate as discussed above, some defects become a problem which affects the entire manufactured product, and has a large influence on yield.

A method in which the number of processes is reduced as much as possible, and manufacturing can be performed simply in a short period of time can be given as one method of achieving the cost reduction. A display device is manufactured with a structure that uses TFTs with a single polarity type, n-channel TFTs or p-channel TFTs, instead of a CMOS structure for the driver circuit. Processes for adding an impurity which imparts a conductivity to a semiconductor layer can thus be simply cut in half, and in addition, the number of photomasks can be reduced. This is extremely effective from the view point of cost-related merits.

A conventionally known single polarity type circuit is explained here.

FIG. 12A shows an example in which an inverter is structured by two n-channel TFTs. The inverter is a two input type

inverter with signals input to gate electrodes of TFTs **1201** and **1202**. An inverted signal of one input is used as the other input.

Operation of the inverter shown in FIG. **12A** is explained simply here. Note that the terms “gate electrode, input terminal, and output terminal”, and the terms “gate electrode, source region, and drain region” are used separately in this specification for the names of the three electrodes of the TFT in explaining the circuit structure and operation. This is because, although there are many cases in which the voltage between the gate and the source is considered in explaining TFT operation, it is difficult to clearly differentiate the source region and the drain region of the TFT based upon the structure of the TFT and the use of unified names may, instead of being helpful, lead to confusion developing. The terms input terminal and output terminal are used in explaining the input and output of signals. The input terminal or the output terminal is referred to as the source region, and the other is referred to as the drain region, in explaining the relationship of the electric potential between the electrodes of the TFT.

First, operation of the two input inverter of FIG. **12A** is explained. When H level is input to a first input (In) and L level is input to a second input (Inb), the TFT **1201** turns off and the TFT **1202** turns on. L level therefore appears in an output (Out) and the electric potential of the output becomes VSS. On the other hand, when L level is input to the first input (In), and H level is input to the second input (Inb), the TFT **1201** turns on the TFT **1202** turns off. H level therefore appears in the output (Out) to pulled up to the VDD side.

At this point, the electric potential is considered when the output (Out) become the H level.

The L level is input to the gate electrode of the TFT **1202** when the H level is input to the gate electrode of the TFT **1201** in FIG. **12A**. The TFT **1201** is therefore on, and the TFT **1202** is therefore off. Accordingly, the electric potential of the output (Out) begins to rise, and the voltage between the gate and the source of the TFT **1201** becomes equal to the threshold value V_{thN} when the electric potential of the output (Out) becomes $(VDD - V_{thN})$. That is, the TFT **1201** turns off at this instant, and therefore the electric potential of the output (Out) cannot rise any further.

A circuit in which a plurality of stages of the inverters shown FIG. **12A** are connected in series is shown in FIG. **12B**. The output of a certain stage becomes the input of the next stage with this type of circuit. As discussed above, waveforms in which the amplitude is attenuated by V_{thN} with respect to the Input signal appear in an output (Out i) of a first stage and an output (Out ii) of the next stage. An output (Out iii) of a third stage is additionally attenuated by V_{thN} compared with the first stage output (FIG. **12C**). Similarly, attenuation of the amplitude due to the threshold voltage continues to develop and overlap throughout the stages, the amplitude of the waveform shrinks rapidly, and the circuit cannot function as a satisfactory circuit.

A boot strap method is known in order to resolve this problem in structuring the circuit by using single polarity type TFTs. A basic circuit which functions by using the boot strap method is shown in FIG. **13A**.

FIG. **13A** is an inverter structured by three n-channel TFTs **1301** to **1303** and a capacitor means **1304**, as disclosed in JP 3092596 B. A signal is input to a gate electrode of the TFT **1303**, and the inverted signal of the signal is input to an input terminal of the TFT **1301**.

Operation is explained. The amplitude of the input signal is VDD to VSS here. Refer to FIG. **13A** and FIG. **13B**. FIG. **13B**

is a diagram showing an input signal (In), an electric potential (Vf) of a gate electrode of the TFT **1302**, and an output signal (Out).

When a H level signal is input to the input (In), and a L level signal is input to the inverted input (Inb), the electric potential of the gate electrode of the TFT **1301** is VDD to be in an on state, and therefore the electric potential of the gate electrode of the TFT **1302** is L level to turn off. On the other hand, the H level is input to the gate electrode of the TFT **1303** to turn on, and L level appears at the output (Out).

When a L level signal is input to the input (In), and an H level signal is input to the inverted input (Inb), the electric potential of the gate electrode of the TFT **1301** is VDD to be in an on state, and therefore the electric potential of the gate electrode of the TFT **1302** is H level. However, the electric potential of the gate electrode of the TFT **1301** is VDD, and therefore the electric potential of an output terminal of the TFT **1301**, that is the electric potential of the gate electrode of the TFT **1302**, becomes $(VDD - V_{thN})$ to place the TFT **1301** in an off state. The gate electrode of the TFT **1302** is thus placed in a floating state at this instant. On the other hand, the TFT **1303** turns off.

The voltage between the gate and the source of the TFT **1302** rises above the TFT threshold voltage, the TFT **1302** therefore turns on, and the electric potential of an output terminal of the TFT **1302** is pulled up the to VDD side. However, the electric potential of the gate electrode of the TFT **1302** is $(VDD - V_{thN})$ at this point, and the electric potential of the output terminal of the TFT **1302** can thus only increase to $(VDD - 2V_{thN})$.

The capacitor **1304** is formed between the output terminal and the gate electrode of the TFT **1302**, however, and the gate electrode of the TFT **1302** is in a floating state. Therefore the electric potential of the gate electrode of the TFT **1302** rises by ΔV_f shown in (ii) of FIG. **13B** due to capacitive coupling along with the rise in the electric potential of the output terminal of the TFT **1302**. The electric potential of the gate electrode of the TFT **1302** is thus greater than $VDD + V_{thN}$, and therefore the electric potential of the output terminal of the TFT **1302** then becomes equal to VDD. Note that a dotted line denoted by reference number **1350** in (iii) of FIG. **13B** is an output example in the case of using the inverter shown in FIGS. **12A** and **12B**.

The inverter shown in FIG. **13A** outputs an inverted signal without amplitude attenuation due to the threshold value of the TFT by the aforementioned procedure. A method of operating the electric potential of a node in a floating state by utilizing capacitive coupling between two nodes is referred to as a boot strap method.

It takes time for charging a load in the case in which the load attached to the later stage is large in an inverter that uses a boot strap method, and therefore the rise time becomes long. It is possible to increase the effect of the boot strap by making the capacitor **1304** larger. Conversely, however, a delay in the increase of the electric potential of the output with respect to the input becomes long if the capacitor is made too large, thus the size of the capacitor is limited.

The rise time become long, or the boot strap may not function sufficiently and the amplitude of the output signal may not be able to be normalized (specifically, H level may not be sufficiently brought up), in the cases in which the load attached to the later stage of the output is additionally large, the amplitude of the input signal is small (H level is low), the threshold value of the TFT is large, and parasitic capacitance

5

in the gate electrode of the TFT in a floating state is large during boot strap operations, and similar cases.

SUMMARY OF THE INVENTION

The present invention has been made in view of the above, and an object of the present invention is therefore to provide a circuit which with a high load driving capability, which is structured to make a rise time short and to make the amplitude of an output signal normal in cases stated above.

As shown in FIG. 1A, there is a structure in which two TFTs are added to the structure of FIG. 13A. The TFTs 1302 and 1303 in FIG. 13A have roles for boot strap operation and for electrical charge and discharge of a load of a latter stage. However, TFTs 102 and 103 contribute only to boot strap operations in the structure shown in FIG. 1A, and TFTs 105 and 106 are formed as TFTs that perform electric charge and discharge of a load. With such structure, it is possible to obtain good operation with no loss of function even in the case in which the load attached to a later stage becomes somewhat large.

In FIG. 1A, the electric potential of a gate electrode of the TFT 102 in a floating state is taken as V_1 , and the electric potential of an output electrode of the TFT 102 at this time is taken as V_2 . A capacitor 104 and a capacitance due to parasitic capacitance and the like exist in the gate electrode of the TFT 102, and their values are taken as C_1 and C_0 , respectively.

V_2 fluctuates from $V_2(0)$ to $V_2(1)$ (where $V_2(0) < V_2(1)$). If the value of this fluctuation is taken as ΔV_2 , the electric potential of V_1 also fluctuates from $V_1(0)$ to $V_1(1)$ (where $V_1(0) < V_1(1)$) due to capacitive coupling of C_1 . If the value of the fluctuation is taken as ΔV_1 , the relationship can be shown by the following equation:

$$\Delta V_1 = \Delta V_2 [C_1 / (C_0 + C_1)] \quad (\text{Eq. 1})$$

There are two ways for increasing ΔV_1 , namely increasing the amount of fluctuation in the electric potential of the gate electrode of the TFT 102 in a floating state: (1) increasing the value of $[C_1 / (C_0 + C_1)]$, and (2) increasing ΔV_2 . In the former case, the coupling capacitance C_1 between the gate electrode and the output electrode of the TFT 102 sufficiently is made large with respect to the parasitic capacitance C_0 . In the latter case, $\Delta V_2 = [V_2(1) - V_2(0)]$, and therefore a method of reducing $V_2(0)$ and a method of increasing $V_2(1)$ can be considered. It is difficult to increase $V_2(1)$ to be equal to or greater than VDD with this structure, and therefore the method of reducing $V_2(0)$ is employed.

The voltage between a gate and a source of the TFT 102 can be increased by reducing $V_2(0)$, and a larger amount of drain current can be made to flow. Shortening of the rise time can thus be expected.

In order to achieve such means, as shown in FIG. 1B, a capacitor means 155 is formed between a gate electrode and an output terminal of a TFT 153 in addition to a capacitor means 154 formed between a gate electrode and an output terminal of a TFT 152.

The load driving capability can be increased with such structure, and therefore the number of stages for buffers and the like can be made smaller, which lead to reduction in the surface area occupied by circuits.

The driver circuit and the pixel portion can be structured by using TFTs with the single polarity, and therefore a portion of processes for adding impurity elements to semiconductor layers can be omitted in a process of manufacturing a display device.

6

Structures of the present invention are described below.

A semiconductor device according to the present invention is characterized by comprising:

first and second transistors each comprising an input terminal electrically connected to a first electric power source;

third and fourth transistors each comprising an input terminal electrically connected to a second electric power source;

a voltage compensator circuit comprising: a fifth transistor comprising an output terminal electrically connected to a gate electrode of the first transistor and a gate electrode of the second transistor, and a capacitor between the output terminal of the fifth transistor and an output terminal of the first transistor;

a first signal input portion for inputting a first signal to a gate electrode of the third transistor and a gate electrode of the fourth transistor,

a second signal input portion for inputting a second signal to an input terminal of the fifth transistor; and

a signal output portion,

in which:

each of the first through the fifth transistors have the same conductivity type,

the output terminal of the first transistor and an output terminal of the third transistor are electrically connected,

an output terminal of the second transistor and an output terminal of the fourth transistor are electrically connected to the signal output portion,

a gate electrode of the fifth transistor is electrically connected to the first electric power source or to a third electric power source, and

the voltage compensator circuit compensates for amplitude attenuation of a signal output from the signal output portion.

A semiconductor device according to the present invention is characterized by comprising:

first and second transistors each comprising an input terminal electrically connected to a first electric power source;

third and fourth transistors each comprising an input terminal electrically connected to a second electric power source;

a voltage compensator circuit comprising: a fifth transistor comprising an output terminal electrically connected to a gate electrode of the first transistor and a gate electrode of the second transistor; a first capacitor between a gate electrode of the first transistor and an output terminal of the first transistor; and a second capacitor between a gate electrode of the third transistor and an output terminal of the third transistor;

a first signal input portion for inputting a first signal to a gate electrode of the third transistor and a gate electrode of the fourth transistor,

a second signal input portion for inputting a second signal to an input terminal of the fifth transistor; and

a signal output portion,

in which:

each of the first through the fifth transistors have the same conductivity type,

the output terminal of the first transistor and the output terminal of the third transistor are electrically connected,

an output terminal of the second transistor and an output terminal of the fourth transistor are electrically connected to the signal output portion,

7

a gate electrode of the fifth transistor is electrically connected to the first electric power source or to a third electric power source, and

the voltage compensator circuit compensates for amplitude attenuation of a signal output from the signal output portion.

The semiconductor device according to the present invention is characterized in that the capacitor is formed by:

two electrodes selected from the group consisting of an active layer, a gate electrode, and a wiring; and an insulating material between the two electrodes.

The semiconductor device according to the present invention is characterized in that one of the first and second capacitor means is formed by:

two electrodes selected from the group consisting of an active layer, a gate electrode, and a wiring; and an insulating material between the two electrodes.

The semiconductor device according to the present invention is characterized in that:

electric potential of the second electric power source is less than electric potential of the first electric power source when the conductivity type is n-channel, and

the electric potential of the second electric power source is more than the electric potential of the first electric power source when the conductivity type is p-channel.

The semiconductor device according to the present invention is characterized in that:

electric potential of the third electric power source is more than electric potential of the second electric power source and less than electric potential of the first electric power source when the conductivity type is n-channel, and

the electric potential of the third electric power source is less than the electric potential of the second electric power source and more than the electric potential of the first electric power source when the conductivity type is p-channel.

A semiconductor device according to the present invention is characterized by comprising:

first and second transistors each comprising an input terminal electrically connected to a first electric power source;

third and fourth transistors each comprising an input terminal electrically connected to a second electric power source;

a voltage compensator circuit comprising: a fifth transistor comprising an input terminal electrically connected to the first electric power source and an output terminal electrically connected to a gate electrode of the first transistor and a gate electrode of the second transistor; a sixth transistor comprising an input terminal electrically connected to the second electric power source and an output terminal electrically connected to the gate electrode of the first transistor and the gate electrode of the second transistor; and a capacitor between the gate electrode and an output terminal of the first transistor;

a first signal input portion for inputting a first signal to a gate electrode of the third transistor, a gate electrode of the fourth transistor, and a gate electrode of the sixth transistor,

a second signal input portion for inputting a second signal to an input terminal of the fifth transistor; and

a signal output portion,

in which:

each of the first through the sixth transistors have the same conductivity type,

8

the output terminal of the first transistor and an output terminal of the third transistor are electrically connected,

an output terminal of the second transistor and an output terminal of the fourth transistor are electrically connected to the signal output portion,

a gate electrode of the fifth transistor is electrically connected to the first electric power source or to a third electric power source, and

the voltage compensator circuit compensates for amplitude attenuation of a signal output from the signal output portion.

A semiconductor device according to the present invention is characterized by comprising:

first and second transistors each comprising an input terminal electrically connected to a first electric power source;

third and fourth transistors each comprising an input terminal electrically connected to a second electric power source;

a voltage compensator circuit comprising: a fifth transistor comprising an input terminal electrically connected to the first electric power source and an output terminal electrically connected to a gate electrode of the first transistor and a gate electrode of the second transistor; a sixth transistor comprising an input terminal electrically connected to the second electric power source and an output terminal electrically connected to the gate electrode of the first transistor and the gate electrode of the second transistor, a first capacitor between the gate electrode and an output terminal of the first transistor; and a second capacitor between a gate electrode and an output terminal of the first transistor;

a first signal input portion for inputting a first signal to the gate electrode of the third transistor, a gate electrode of the fourth transistor, and a gate electrode of the sixth transistor,

a second signal input portion for inputting a second signal to an input terminal of the fifth transistor; and

a signal output portion,

in which:

each of the first through the sixth transistors have the same conductivity type,

the output terminal of the first transistor and an output terminal of the third transistor are electrically connected,

an output terminal of the second transistor and an output terminal of the fourth transistor are electrically connected to the signal output portion,

a gate electrode of the fifth transistor is electrically connected to the first electric power source or to a third electric power source, and

the voltage compensator circuit compensates for amplitude attenuation of a signal output from the signal output portion.

The semiconductor device according to the present invention is characterized in that the capacitor is formed by:

two electrodes selected from the group consisting of an active layer, a gate electrode, and a wiring; and an insulating material between the two electrodes.

The semiconductor device according to the present invention is characterized in that one of the first and second capacitor means is formed by:

two electrodes selected from the group consisting of an active layer, a gate electrode, and a wiring; and an insulating material between the two electrodes.

The semiconductor device according to the present invention is characterized in that:

wherein electric potential of the second electric power source is less than electric potential of the first electric power source when the conductivity type is a n-channel, and

wherein the electric potential of the second electric power source is more than the electric potential of the first electric power source when the conductivity type is p-channel.

BRIEF DESCRIPTION OF THE DRAWINGS

In the accompanying drawings:

FIGS. 1A to 1C are diagrams showing an embodiment mode of the present invention;

FIGS. 2A to 2E are diagrams showing the electric potential of each node of the circuit shown in FIG. 1A to 1C during boot strap operation;

FIG. 3 is a diagram showing the structure of a source signal line driver circuit used in a display device manufactured by an embodiment;

FIGS. 4A and 4B are diagrams showing the structure of a shift register used in a display device manufactured by an embodiment;

FIGS. 5A to 5C are diagrams showing the structure of a buffer used in a display device manufactured by an embodiment;

FIGS. 6A to 6D are diagrams showing the structure of a level shifter used in a display device manufactured by an embodiment;

FIGS. 7A to 7C are diagrams showing an example of a process of manufacturing a display device;

FIGS. 8A to 8C are diagrams showing the example of a process of manufacturing a display device;

FIGS. 9A and 9B are diagrams showing an embodiment of the present invention;

FIGS. 10A to 10C are schematic and cross sectional diagrams of a display device;

FIGS. 11A to 11E are diagrams showing the relationship between CMOS inverter operation and load;

FIGS. 12A to 12C are diagrams showing inverter operation by single polarity TFTs;

FIGS. 13A and 13B are diagrams showing circuit operation in accordance with a boot strap method;

FIG. 14 is a diagram for explaining operational timing for a shift register;

FIG. 15 is a diagram showing the structure of a gate signal line driver circuit used in a display device manufactured by an embodiment;

FIGS. 16A to 16C are diagrams showing an example of a process of manufacturing a display device;

FIGS. 17A to 17G are diagrams showing examples of electronic equipment to which it is possible to apply the present invention;

FIGS. 18A and 18B are diagrams showing an embodiment using a level shifter of the present invention;

FIGS. 19A and 19B are diagrams showing an example of a process of manufacturing of a light emitting device;

FIGS. 20A and 20B are diagrams showing an example of a process of manufacturing of a light emitting device;

FIG. 21 is a diagram showing an embodiment of the present invention; and

FIGS. 22A to 22C are mask-layout diagrams of the structure shown in FIG. 21, and a photograph of a manufactured circuit.

DETAILED DESCRIPTION OF THE PREFERRED EMBODIMENTS

Embodiment Mode

Operation of the circuits shown in FIGS. 1A and 1B is explained. Basic circuit operation is explained using FIGS. 13A and 13B. The L level appears from a signal output portion (Out) when the H level is input to a first signal input portion (In) and the L level is input to a second signal input portion (Inb), and the H level appears from the signal output portion (Out) when the L level is input to the first signal input portion (In) and the H level is input to the second signal input portion (Inb). At this time, attenuation in the voltage amplitude caused by the TFT threshold value is compensated by using a boot strap method, and an output with a normal amplitude can be obtained. In addition, boot strap operations, and load charge and discharge operations are each performed by independent TFTs, and therefore high speed operation is possible, and a sufficient load driving capability can be achieved.

In addition, there is a specific operation at the instant of changing the signal input to the first signal input portion (In) from the H level to the L level in the structure of FIG. 1B. An explanation is as follows.

FIG. 1C is a diagram showing signal waveforms of respective portions related to operation of an inverter to which the present invention is applied. The operation is explained using FIGS. 1B and 1C. Note that the amplitude of the input signal is from VDD to VSS.

The H level is input to the first signal input portion (In), and TFTs 153 and 157 are placed in an on state. On the other hand, VDD is always input to a gate electrode of a TFT 151, and gate electrodes of TFTs 152 and 156 become the L level through the TFT 151 to be turn off when the L level is input to the second signal input portion (Inb). The L level therefore appears in the signal output portion (Out).

The signal input to the first signal input portion (In) then begins to become the L level from the H level. The TFT turns off when the electric potential falls below the threshold value of the TFT 153. An output terminal of the TFT 153 is therefore momentarily in a floating state. In addition, the electric potential of the signal input to the first signal input portion (In) drops, that is, the electric potential of a gate electrode of the TFT 153 drops. The electric potential of the output terminal of the TFT 153 in a floating state then drops by an amount denoted by ΔV_p , due to capacitive coupling by a capacitor 155 between the gate electrode and the output terminal of the TFT 153, as shown in FIG. 1C.

At the same time, the signal input to the second signal input portion (Inb) becomes the H level from the L level. The electric potential of the gate electrodes of the TFTs 152 and 156 therefore rises to be placed in a floating state when the electric potential becomes $(VDD - V_{thN})$.

the electric potential of an output terminal of the TFT 152 is $(VSS - \Delta V_p)$ here, and the voltage between a gate and a source of the TFT 152 becomes larger than the voltage between the gate and the source of the TFT 1302 in the circuit shown in FIG. 13A. That is, more electric current flows in the TFT 152 than in the TFT 1302.

The increase in the electric potential of the output terminal of the TFT 152 therefore becomes faster than the increase in the electric potential of the output terminal of the TFT 1302. Due to the boot strap, the speed, at which the electric potentials of the gate electrodes of the TFTs 152 and 156 lift up, also becomes faster than the speed at which the electric potential of the gate electrode of the TFT 1302 does.

11

The H level therefore appears at the signal output portion (Out), and the time for the increase in the electric potential becomes shorter than that of the circuit shown in FIG. 13A. In addition, the amount of electric current flowing in the TFTs 152 and 156 increases, and therefore the electric potential of the gate electrode of the TFT 152 can also increase to a higher value than (VDD+VthN) due to normal boot strap operations if the load attached to the output stage is large. In the case of the circuit using the conventional boot strap method shown in FIG. 13A, there are some cases where the electric potential of the gate electrode of the TFT 1302 in a floating state cannot be brought up to an electric potential that is higher than (VDD+VthN), as shown in the dotted line waveform in FIG. 1B, and therefore the amplitude of the output signal is also attenuated.

With FIGS. 2A and 2E, transitional operations at the instant of changing the signal input to the first signal input portion (In) from the H level to the L level are explained in detail.

FIG. 2A is similar to the circuit shown in FIG. 1B. It is noted that attention is paid to only the capacitor 154 and the capacitor 155, and changes in the electric potential at the nodes of both ends of the capacitors here.

FIG. 2B is a diagram showing an extraction of the capacitors 154 and 155. A node which is corresponding to the gate electrode of the TFT 152 is denoted by V152G, a node which is corresponding to the output terminal of the TFT 152 is denoted by V152S, and a node which is corresponding to a gate electrode of the TFT 153 is denoted by V153G.

FIG. 2C shows a state in which the H level is input to the first signal input portion (In), and the L level is input to the second signal input portion (Inb). The electric potential of the node V152G at this point is VSS, the electric potential of the node V152S is VSS, and the electric potential of the node V153G is VDD.

As shown in FIG. 2D, the signal input to the first signal input portion (In) then becomes the L level from the H level. The electric potential of the gate electrode of the TFT 153 therefore drops, and the TFT 153 turns off when the electric potential falls lower than the threshold value. The node V152S is then placed in a floating state. In addition, the electric potential of the node V153G also drops after falling below the threshold value of the TFT 153, and the electric potential becomes VSS. The electric potential of the node V152S drops by ΔV_f due to capacitive coupling by the capacitor 155 with the node 153G. The electric potential of the node V153G therefore becomes (VSS- ΔV_f), as shown in FIG. 2D.

At the same time, the signal input to the second signal input portion (Inb) becomes the H level from the L level. The TFT 152 thus turns on, and the node V152G is placed in a floating state when the electric potential of the node V152G becomes (VDD-VthN). Next, there is a further increase by ΔV_f due to the boot strap, and the electric potential of the node V152G becomes (VDD-VthN+ ΔV_f). The electric potential of the node V152S therefore increases to VDD. At the same time, the electric potential of the gate electrode of the TFT 156 also becomes equal to the electric potential of the node V152G, and therefore the H level increased normally to VDD appears in the signal output portion (Out).

It is possible to obtain a sufficient driving ability in accordance with the operations shown above in the present invention, even if there is a large load in a later stage. Note that a structure that uses p-channel TFTs may of course be employed although an example of a case in which the polarity of the TFTs is n-channel is explained in this Embodiment Mode.

12

EMBODIMENTS

Embodiments of the present invention are discussed below.

Embodiment 1

In the circuits shown in FIGS. 1A and 1B and explained in the Embodiment Mode, the role of placing the gate electrode of the TFT 102 in a floating state is accomplished by only the TFT 101. There is the fact discussed above that the gate electrode of the TFT 102 is placed in a floating state when the electric potential of the gate electrode of the TFT 102 becomes (VDD-VthN). If the H level of the input signal is not satisfy (VDD-VthN), the TFT 101 does not turn off, and therefore the gate electrode of the TFT 102 is not placed in a floating state, and accordingly the boot strap does not work.

The circuit shown in FIG. 9A is used in the above case. A difference between the circuits shown in FIG. 9A and in FIG. 1A is that two TFTs, a TFT 901 and a TFT 902, are used in order to place a gate electrode of a TFT 903 in a floating state. The above stated condition is considered with the circuit of FIG. 9A. The voltage amplitude of an input signal is VDD0 (Hi) to VSS(Lo), and the relationship among the electric potentials is:

$$VSS < V_{thN} < VDD0 < (VDD - V_{thN}) \quad (\text{Eq. 2}).$$

When the H level is input to the first signal input portion (In) and the L level is input to the second signal input portion (Inb), the TFT 902, a TFT 904, and a TFT 908 turn on. In addition, the TFT 901 turns off, and therefore the L level is input to a gate electrode of the TFT 903 and a gate electrode of a TFT 907 and the TFTs 903 and 907 turn off. The L level thus appears in the signal output portion (Out).

On the other hand, when the L level is input to the first signal input portion (In) and the H level is input to the second signal input portion (Inb), then the TFT 902, the TFT 904, and the TFT 908 turns off. Further, the TFT 901 turns on, and the electric potentials of the gate electrodes of the TFTs 903 and 907 increase. The electric potential of the gate electrode of the TFT 901 at this point is VDD0, and therefore a floating state arises with certainty when the electric potential of the gate electrodes of the TFTs 903 and 907 becomes (VDD0-VthN). The H level then appears normally in the signal output portion (Out) due to the boot strap, as shown in the Embodiment Mode.

The output with an amplitude of (VDD-VSS) can be obtained for input of signals with an amplitude of (VDD0-VSS) if the circuit shown in FIG. 9A is used. That is, the circuit can be made to function as a level shifter.

FIG. 9B is a similar circuit. A gate electrode of a TFT 911 is connected to an electric power source VDD, and signals are input only to a gate electrode of a TFT 912. It is thus possible to obtain similar operation to the circuit shown in FIG. 9A with a single input type circuit.

Embodiment 2

This embodiment gives a description on a method of manufacturing TFTs for driving circuit provided in a pixel portion and in the periphery of the pixel portion formed on the same substrate. Note that the processes of manufacturing a liquid crystal device is described as an example here, as mentioned above, there is not particular limitation on the liquid crystal display device.

First, as shown in FIG. 7A, a base film 5002 is formed from an insulating film such as a silicon oxide film, a silicon nitride film, and a silicon oxynitride film on a glass substrate 5001.

The substrate **5001** is formed of barium borosilicate glass typical example of which is Corning #7059 glass or Corning #1737 glass (product of Corning Incorporated), or of aluminoborosilicate glass. The base film **5002** is, for example, (now shown) a laminate of a silicon oxynitride film that is formed from SiH_4 , NH_3 , and N_2O by plasma CVD to a thickness of 10 to 200 nm (preferably 50 to 100 nm) and a silicon oxynitride hydride film formed from SiH_4 and N_2O by plasma CVD to a thickness of 50 to 200 nm (preferably 100 to 150 nm).

A semiconductor film having an amorphous structure is crystallized by laser crystallization or a known thermal crystallization method to form a crystalline semiconductor film. The crystalline semiconductor film makes island-like semiconductor layers **5003** to **5005**. The island-like semiconductor layers **5003** to **5005** each have a thickness of 25 to 80 nm (preferably 30 to 60 nm). No limitation is put on the choice of material of the crystalline semiconductor film but it is preferable to use silicon or a silicon germanium (SiGe) alloy.

When the crystalline semiconductor film is formed by laser crystallization, a pulse oscillation-type or continuous wave excimer laser, YAG laser, or YVO_4 laser is used. Laser light emitted from a laser as those given in the above is desirably collected into a linear beam by an optical system before irradiating the semiconductor film. Conditions of crystallization are set suitably by an operator. However, if an excimer laser is used, the pulse oscillation frequency is set to 30 Hz and the laser energy density is set to 100 to 400 mJ/cm^2 (typically 200 to 300 mJ/cm^2). If a YAG laser is used, second harmonic thereof is employed and the pulse oscillation frequency is set to 1 to 10 kHz while setting the laser energy density to 300 to 600 mJ/cm^2 (typically 350 to 500 mJ/cm^2). The laser light is collected into a linear beam having a width of 100 to 1000 μm , for example, 400 μm , to irradiate the entire substrate. The substrate is irradiated with the linear laser light with the beam overlapping each other at an overlap ratio of 80 to 98%.

Next, a gate insulating film **5006** is formed so as to cover the island-like semiconductor layers **5003** to **5005**. The gate insulating film **5006** is formed from an insulating film containing silicon by plasma CVD or sputtering to a thickness of 40 to 150 nm. In this embodiment, a silicon oxynitride film having a thickness of 120 nm is used. Needless to say, the gate insulating film is not limited to a silicon oxynitride film but may be a single layer or a laminate of other insulating films containing silicon. For example, if a silicon oxide film is used for the gate insulating film, the film is formed by plasma CVD in which TEOS (tetraethyl orthosilicate) is mixed with O_2 and the reaction pressure is set to 40 Pa, the substrate temperature to 300 to 400° C., the frequency is set high to 13.56 MHz , and the power density is set to 0.5 to 0.8 W/cm^2 for electric discharge. The silicon oxide film thus formed can provide the gate insulating film with excellent characteristics when it is subjected to subsequent thermal annealing at 400 to 500° C.

On the gate insulating film **5006**, a first conductive film **5007** and a second conductive film **5008** for forming gate electrodes are formed. In this embodiment, the first conductive film **5007** is a Ta film with a thickness of 50 to 100 nm and the second conductive film **5009** is a W film with a thickness of 100 to 300 nm (FIG. 7A).

The Ta film is formed by sputtering in which Ta as a target is sputtered with Ar. In this case, an appropriate amount of Xe or Kr is added to Ar to ease the internal stress of the Ta film and thus prevent the Ta film from peeling off. The resistivity of a Ta film in α phase is about 20 $\mu\Omega\text{cm}$ and is usable for a gate electrode. On the other hand, the resistivity of a Ta film in β phase is about 180 $\mu\Omega\text{cm}$ and is not suitable for a gate electrode. A Ta film in α phase can readily be obtained when

a base with a thickness of about 10 to 50 nm is formed from tantalum nitride (TaN) that has a crystal structure approximate to that of the α phase Ta film.

The W film is formed by sputtering with W as a target. Alternatively, the W film may be formed by thermal CVD using tungsten hexafluoride (WF_6). In either case, the W film has to have a low resistivity in order to use the W film as a gate electrode. A desirable resistivity of the W film is 20 $\mu\Omega\text{cm}$ or lower. The resistivity of the W film can be reduced by increasing the crystal grain size, but if there are too many impurity elements such as oxygen in the W film, crystallization is inhibited to raise the resistivity. Accordingly, when the W film is formed by sputtering a W target with a purity of 99.9999% is used and a great care is taken not to allow impurities in the air to mix in the W film being formed. As a result, the W film can have a resistivity of 9 to 20 $\mu\Omega\text{cm}$.

Although the first conductive film **5007** is a Ta film and the second conductive film **5008** is a W film in this embodiment, there is no particular limitation. The conductive films may be formed of any element selected from a group consisting of Ta, W, Mo, Al, and Cu, or of an alloy material or compound material mainly containing the elements listed above. A semiconductor film, typically a polycrystalline silicon film doped with an impurity element such as phosphorus, may be used instead. Other desirable combinations of materials for the first and second conductive films than the one shown in this embodiment include: tantalum nitride (TaN) for the first conductive film **5007** and W for the second conductive film **5008**; tantalum nitride (TaN) for the first conductive film **5007** and Al for the second conductive film **5008**; and tantalum nitride (TaN) for the first conductive film **5007** and Cu for the second conductive film **5008**.

Next, a resist mask **5009** is formed to carry out first etching treatment for forming electrodes and wiring lines. In this embodiment, ICP (inductively coupled plasma) etching is employed in which CF_4 and Cl_2 are mixed as etching gas and an RF (13.56 MHz) power of 500 W is given to a coiled electrode at a pressure of 1 Pa to generate plasma. The substrate side (sample stage) also receives an RF (13.56 MHz) power of 100 W so that a substantially negative self-bias voltage is applied. When the mixture of CF_4 and Cl_2 is used, the W film and the Ta film are etched to the same degree.

Under the above etching conditions, if the resist mask is properly shaped, the first conductive films and the second conductive film are tapered around the edges by the effect of the bias voltage applied to the substrate side. The angle of the tapered portions is 15° to 45°. In order to etch the conductive films without leaving any residue on the gate insulating film, the etching time is prolonged by about 10 to 20%. The selective ratio of the W film to the silicon oxynitride film is 2 to 4 (typically 3), and therefore a region where the silicon oxynitride film is exposed is etched by about 20 to 50 nm by the over-etching treatment. In this way, first shape conductive layers **5010** to **5013** comprising first conductive layers **5010a** to **5013a** and second conductive layers **5010b** to **5013b** are formed from the first conductive film and the second conductive film through the first etching treatment. At this point, regions of the gate insulating film **5006** that are not covered with the first shape conductive layers **5010** to **5013** are etched and thinned by about 20 to 50 nm. (FIG. 7B)

First doping treatment is conducted next for doping of an impurity element that gives the N-type conductivity (FIG. 7B). Ion doping or ion implanting is employed. In ion doping, the dose is set to 1×10^{13} to 5×10^{14} atoms/ cm^2 and the acceleration voltage is set to 60 to 100 keV. The impurity element that gives the N-type conductivity is an element belonging to Group 15, typically, phosphorus (P) or arsenic (As). Here,

phosphorus (P) is used. In this case, the conductive layers **5010** to **5013** serve as masks against the impurity element that gives the n-type conductivity, and first impurity regions **5014** to **5016** are formed in a self-aligning manner. The first impurity regions **5014** to **5016** each contain the impurity element that gives the N-type conductivity in a concentration of 1×10^{20} to 1×10^{21} atoms/cm³.

Next, as shown in FIG. 7C, a second etching process is performed. The ICP etching method is similarly used in which CF₄, Cl₂, and O₂ are mixed as the etching gases, and an RF power of 500 W is applied to a coil type electrode under a pressure of 1 Pa to generate plasma. An RF power of 50 W is applied to the side of the substrate (sample stage), and a low self bias voltage as compared with the first etching process is applied thereto. In accordance with the conditions, the W film as the second conductive layer is anisotropically etched, and the Ta film as the first conductive layer is anisotropically etched at an etching rate lower than the W film to form second shape conductive layers **5017** to **5020** (first conductive layers **5017a** to **5020a** and second conductive layers **5017b** to **5020b**). Reference number **5006** designates a gate insulating film, and regions which are not covered with the second shape conductive layers **5017** to **5020** are etched into a film thickness of about 20 to 50 nm, to form thin regions.

The reaction of the W film and the Ta film to etching by the mixture gas of CF₄ and Cl₂ can be deduced from the vapor pressure of radical or ion species generated and of reaction products. Comparing the vapor pressure among fluorides and chlorides of W and Ta, WF₆ that is a fluoride of W has an extremely high vapor pressure while the others, namely, WCl₅, TaF₅, and TaCl₅ have a vapor pressure about the same degree. Accordingly, the W film and the Ta film are both etched with the mixture gas of CF₄ and Cl₂. However, when appropriate amount of O₂ is added to this mixture gas, CF₄ and O₂ react to each other to be changed into CO and F, generating a large amount of F radicals or F ions. As a result, the W film whose fluoride has a high vapor pressure is etched at an increased etching rate. On the other hand, the etching rate of the Ta film is not increased much when F ions are increased in number. Since Ta is more easily oxidized than W, the addition of O₂ results in oxidation of the surface of the Ta film. The oxide of Ta does not react with fluorine or chlorine and therefore the etching rate of the Ta film is reduced further. Thus a difference in etching rate is introduced between the W film and the Ta film, so that the etching rate of the W film is set faster than the etching rate of the Ta film.

Then second doping treatment is conducted (FIG. 7C). In the second doping treatment, the film is doped with an impurity element that gives the N-type conductivity in a dose smaller than in the first doping treatment and at a high acceleration voltage. For example, the acceleration voltage is set to 70 to 120 KeV and the dose is set to 1×10^{13} atoms/cm² to form new impurity regions inside the first impurity regions that are formed in the island-like semiconductor layers in FIG. 7B. While the second conductive layers **5017b** to **5020b** are used as masks against the impurity element, regions under the first conductive layers **5017a** to **5020a** are also doped with the impurity element. Thus formed are second impurity regions **5021** to **5023** overlapping the first conductive layer.

Next, as shown in FIG. 8A, a third etching process is performed. In this embodiment, an ICP etching device is employed and Cl₂ is used as etching gas. Etching is conducted for 70 seconds, setting the flow rate of Cl₂ to 60 (sccm), and an RF power of 350 W is applied to a coil type electrode under a pressure of 1 Pa to generate plasma. An RF power is also applied to the side of the substrate (sample stage) so that a substantially negative self-bias voltage is applied. Through

the third etching process, the first conductive layer is etched to reduce the region, thereby third shape conductive layers **5024** to **5027** (first conductive layers **5024a** to **5027a** and second conductive layers **5024b** to **5027b**) are formed. A portion of the second impurity regions **5021** to **5023** include the third impurity regions **5028** to **5030** that are not covered with the first conductive layer.

Through the steps above, the impurity regions are formed in the respective island-like semiconductor layers. The third shape conductive layers **5024** to **5027** overlapping the island-like semiconductor layers function as gate electrodes of TFTs.

The impurity elements used to dope the island-like semiconductor layers in order to control the conductivity types are activated. The activation step is carried out by thermal annealing using an annealing furnace. Other activation adoptable methods include laser annealing and rapid thermal annealing (RTA). The thermal annealing is conducted in a nitrogen atmosphere with an oxygen concentration of 1 ppm or less, preferably 0.1 ppm or less, at 400 to 700° C., typically 500 to 600° C. In this embodiment, the substrate is subjected to heat treatment at 500° C. for four hours. However, if the wiring line material used for the third shape conductive layers **5024** to **5027** are weak against heat, the activation is desirably made after an interlayer insulating film (mainly containing silicon) is formed in order to protect the wiring lines and others.

Another heat treatment is conducted in an atmosphere containing 3 to 100% hydrogen at 300 to 450° C. for one to twelve hours, thereby hydrogenating the island-like semiconductor layers. The hydrogenation steps are to terminate dangling bonds in the semiconductor layers using thermally excited hydrogen. Alternatively, plasma hydrogenation (using hydrogen that is excited by plasma) may be employed.

As shown in FIG. 8B, a first interlayer insulating film **5031** is formed next from a silicon oxynitride film with a thickness of 100 to 200 nm. A second interlayer insulating film **5032** is formed thereon from an organic insulating material. Thereafter, contact holes are formed corresponding to the first interlayer insulating film **5031**, the second interlayer insulating film **5032**, and the gate insulating film **5006**. A film made of wiring lines material is formed, whereby connection wiring lines **5033** to **5036** and a pixel electrode **5037** are formed by patterning.

The second interlayer insulating film **5032** is a film made of an organic resin. Examples of the usable organic resin includes polyimide, polyamide, acrylic resin, and BCB (benzocyclobutene). Since planarization is a significant aspect of the role of the second interlayer insulating film **5032**, acrylic resin that can level the surface well is particularly preferable. In this embodiment, the acrylic film is thick enough to eliminate the level differences caused by the TFTs. An appropriate thickness of the film is 1 to 5 μm (preferably 2 to 4 μm).

The contact holes are formed by dry etching or wet etching, and include contact holes reaching the impurity regions **5014** to **5016** having the N-type conductivity, the source signal lines, the gate signal lines (now shown), power supply lines (not shown), and gate electrodes **5024** to **5026** (not shown) respectively.

Further, a lamination film of a three layer structure, in which a 100 nm thick Ti film, a 300 nm thick Al film containing Ti, and a 150 nm thick Ti film are formed in succession by sputtering wirings **5033** to **5036**. Of course, other conductive films may be used. As to the pixel electrode **5037**, in a case of that the display device is a reflect type, is formed by a material in high reflectivity. On the other hand, in a case of that the display device is a transmission type, the pixel electrode **5037**

is formed by using a material like Indium Tin Oxide (ITO) or the like that has transparent conductivity.

An opposing substrate **5038** is prepared next. A light shielding film is formed on the opposing substrate **5038**. The light shielding film is formed of a material such as chrome (Cr) into a thickness of 100 to 200 nm.

On the other side, an opposing electrode **5040** is formed in the pixel portion. The opposing electrode is formed by using a transparent conductive material such as ITO. Further, it is preferable that the film thickness of the opposing electrode be from 100 to 120 nm in order to maintain a high transmittivity of visible light.

Orientation films **5041** and **5042** are formed in the active matrix substrate and the opposing substrate. It is preferable that the film thickness of the orientation films **5041** and **5042** be from 30 to 80 nm. Furthermore, materials such as SE7992, for example, manufactured by Nissan Chemical Industries, Ltd., can be used for the orientation films. If an orientation film having a high pre-tilt angle is used, then the generation of disclination can be controlled at the same time as driving the liquid crystal display device by an active matrix method.

The orientation films **5041** and **5042** undergo a rubbing process next. It is preferable that the rubbing direction show a counterclockwise TN (twisted nematic) orientation when the liquid crystal display device is complete.

Although now shown in particular in the figures for Embodiment 2, it is also possible to increase the uniformity of a cell gap by distributing spacers within the pixels or by patterning. A photosensitive resin film is formed and patterned in Embodiment 2, thus forming spacers having a height of 4.0 μm .

The active matrix substrate and the opposing substrate are then bonded by using a sealant **5043**. The thermosetting sealant XN-21S manufactured by Mitsui Chemicals is used as the sealant. A filler is mixed into the sealant. Note that the height of the filler is set to 4.0 μm . After the sealant is hardened, the active matrix substrate and the opposing substrate are sectioned simultaneously into predetermined sizes.

Liquid crystals **5044** are injected next. Considering high speed response characteristics and the like, it is preferable to use a low viscosity liquid crystal material for the liquid crystals. A nematic liquid crystal material having an easily controlled orientation is used in Embodiment 2. High response speed ferroelectric liquid crystals and anti-ferroelectric liquid crystals may of course also be used.

In injection port is sealed by using a UV hardening resin or the like after liquid crystal injection is complete. A polarizing sheet is then attached by a known method. Lastly, a connector (flexible printed circuit: FPC) for connecting the elements formed on the substrate, or terminals pulled out from the circuits with external signal terminals is attached, completing a manufactured product (see FIG. **8C**). This state, one capable of being shipped as a finished product, is referred to as a liquid crystal device within this specification.

Further, the number of photomasks necessary for manufacturing the active matrix substrate can be kept to four (island shape semiconductor layer patten, first wiring pattern (gate wirings, island shape source wirings, capacitor wirings), contact hole pattern, and second wiring pattern (including pixel electrodes and connection electrodes)) in accordance with the processes disclosed in Embodiment 2. As a result, processing can be shortened, and this contributes to a reduction in manufacturing costs and to an increase in yield.

Embodiment 3

An example of manufacturing a display device which has the circuit as shown in the Embodiment Mode and Embodiment 1 is discussed in Embodiment 3.

A schematic diagram of the display device is shown in FIG. **10A**. A pixel portion **1001** is placed in a center portion of a substrate **1000**. A source signal line driver circuit **1002** for controlling source signal lines, and gate signal line driver circuits **1007** for controlling gate signal lines are formed in the periphery of the pixel portion **1001**. Although the gate signal line driver circuits **1007** are placed symmetrically on both side of the pixel portion **1001**, there may be a gate signal driver circuit on only one side thereof.

Signals input from the outside for driving the source signal line driver circuit **1002** and the gate signal line driver circuits **1007** are input through an FPC **1010**. The signals input from the FPC **1010** have small voltage amplitudes, and therefore undergo transformation of the voltage amplitudes by level shifters **1006**, and then, are input to the source signal line driver circuit **1002** and the gate signal line driver circuits **1007** in Embodiment 3.

FIG. **10B** illustrates a cross section taken along line A-A' of FIG. **10A**. The pixel portion **1001**, the source signal line driver circuit **1002**, the gate signal drive circuit (now shown) are formed on the substrate **1000**. The substrate **1000** and a counter substrate **1011** are attached each other by a sealant **1002**, liquid crystals are injected in the gap between the substrates. As shown in FIG. **10A**, the injection entrance is sealed by a sealant **1013** thereafter.

A lead-out wiring **1021** is electrically connected to an FPC side wiring **1022** of an FPC **1010** through an anisotropic conductive film **1023**. Further, as shown in FIG. **10C**, the anisotropic conductive film **1023** has conductive filter **1024**. The lead-out wiring **1021** on the substrate **1000** and the FPC side wiring **1022** on the FPC **1010** are electrically connected to each other through the conductive filler **1024** by heat-pressing the substrata **1000** and the FPC **1010**.

FIG. **3** is a diagram showing the structure of the source signal line driver circuit. The source signal line driver circuit has level shifters **301**, **302**, shift registers **303**, buffers **304**, sampling circuits **305**.

A source side clock signal (S-CK), a source side clock inverted signal (S-CKb), a source side start pulse (S-SP), analog image signals (Video **1-8**) are input to the source signal line driver circuit. Among these signals, the clock signal and the start pulse are input after undergoing amplitude transformation by the level shifters **301** and **302**. Note that although the analog image signals divided into 8 divisions are input in Embodiment 3, substantially there is no limitation when the display device is manufactured.

The structure of the shift registers is shown in FIG. **4**. A block denoted by reference numeral **400** in a block diagram of FIG. **4A** is a pulse output circuit for outputting one stage portion of sampling pulses. Shift registers of FIG. **4A** are structured by n stages (where n is a natural number, $1 < n$) of pulse output circuits.

FIG. **4B** is a diagram showing the structure of the pulse output circuit in detail. The pulse output circuit body is composed of TFTs **401** to **406**, and a capacitor **407**. In the k-th stage pulse output circuit (where k is a natural number, $1 < k < n$), output pulses from the (K-1)-th stage pulse output circuit are input to gate electrodes of the TFTs **401** and **404**, while output pulses from the (k+1)-th stage pulse output circuit are input to gate electrodes of the TFTs **402** and **403**, respectively. Note that start pulses (SP) are input to the gate electrodes of the TFTs **401** and **404** when $k=1$, namely in the initial stage pulse output circuit, and that start pulses (SP) are input to the gate electrodes of the TFTs **402** and **403** when $k=n$, namely in the final stage pulse output circuit.

Circuit operation is explained in detail here with reference to the timing chart shown in FIG. **14**. In the k-th stage pulse

output circuit, the output pulse from the (k-1)-th stage pulse output circuit is input to the gate electrodes of the TFTs 401 and 404 to become H level (a start pulse is input if k=1, namely for the initial stage), and the TFTs 401 turn on (refer to FIG. 14, reference number 1401). The electric potential of a gate electrode of the TFT 405 is pulled up to the VDD side (FIG. 14, reference numeral 1402), and the TFT 401 turns off to the gate electrode of the TFT 405 placed in a floating state when the electric potential becomes $VDD - V_{thN}$. The voltage between a gate and a source of the TFT 405 is greater than the threshold value at this point, and the TFT 405 turns on. On the other hand, pulses are not input to the gate electrodes of the TFTs 402 and 403 to remain at L level and the TFTs 402 and 403 are therefore in an off state. The electric potential of a gate electrode of the TFT 406 is therefore L level to be turned off. The electric potential of an output terminal (SR out) of the pulse output circuit is thus pulled up to the VDD side in accordance with the clock signal becoming H level (S-CK or S-CKb) input to an input electrode of the TFT 405 (FIG. 14, reference numeral 1403). In this state, however, the electric potential of the output terminal (SR out) of the pulse output circuit drops further by the threshold value with respect to the electric potential ($VDD - V_{thN}$) of the gate electrode of the TFT 405, and only an increase to $[VDD - 2(V_{thN})]$ is obtained.

The capacitor 407 is formed between the gate electrode and the output electrode of the TFT 405 here, and in addition, the gate electrode of the TFT 405 is in a floating state. The electric potential of the gate electrode of the TFT 405 is therefore further pulled up from ($VDD - V_{thN}$) by the capacitor 407 in accordance with the rise in the electric potential of the output terminal (SR out) of the pulse output circuit, namely the rise in the electric potential of the output electrode of the TFT 405. In accordance with this operation, the final electric potential of the gate electrode of the TFT 405 becomes higher than ($VDD + V_{thN}$) (FIG. 14, reference number 1402). The electric potential of the output terminal (SR out) of the pulse output circuit is not influenced by the threshold value of the TFT 405, and increases normally to VDD (FIG. 14, reference numeral 1403).

Similarly a pulse is output from the (k+1)-th stage pulse output circuit (FIG. 14, reference numeral 1404). The output pulse of the (k+1)-th stage is returned to the k-th stage and is input to the gate electrodes of the TFTs 402 and 403. The electric potentials of the gate electrodes of the TFTs 402 and 403 become H level, and the TFTs 402 and 403 turn on. The electric potential of the gate electrode of the TFT 405 is pulled down to the VSS side, and the TFT 405 turns off. Simultaneously, the electric potential of the gate electrode of the 406 becomes H level, and the TFT 406 turns on. The electric potential of the output terminal (SR out) of the k-stage pulse output circuit becomes L level.

Pulses with the amplitude between $VDD - VSS$ are then output one after another by similar operations up through the final stage. Circuit operation is also similar for reverse direction scanning.

In the final stage, a pulse is not returned from the next stage, and therefore the clock signal continues to be output through the TFT 405 (FIG. 14, reference numeral 1407). The output pulses from the pulse output circuit of the final stage therefore cannot be used as sampling pulses. Similarly, the output pulses from the initial stage are final output pulses in the case of the reverse direction scanning, and therefore cannot be used as sampling pulses. In the circuit shown in Embodiment 3, the shift register is therefore structured by pulse output circuits with two more stages than the necessary number of stages. The pulse output circuits at both ends are handled as

dummy stages. Even so, it is necessary to stop the final output by some method before the next horizontal period begins, and therefore the final output is stopped at the point where the start pulse for the next horizontal period is input by using the start pulse as the input for the initial stage and the period input for the final stage period.

FIG. 5 shows the structure of the buffers 304. As shown in FIG. 5A, this is a structure having four stages. Only the first stage is a single input, single output type (Buf Unit 1) 501. The second and subsequent stages are two input, two output types (Buf Unit 2) 502.

The circuit structure of the initial stage unit (Buf Unit 1) is shown in FIG. 5B. Signals are input to gate electrodes of TFTs 552, 554 and 556. A gate electrode of a TFT 551 is connected to an input electrode. When H level is input to the gate electrodes of the TFTs 552, 554 and 556 to become in an on state, then the electric potential of gate electrodes of TFTs 553 and 555 become L level, and as a result, an output terminal (out) becomes L level. When L level is input to the gate electrodes of the TFTs 552, 554 and 556, the TFTs 552, 554 and 556 turn off. Since the gate electrode and an input electrode of the TFT 551 are connected and the TFT 551 is normally on, the electric potential of the gate electrodes of the TFT 553 and 555 increase. Similarly to the case of the above-stated shift register, there is capacitive coupling due to a capacitor 557, and the output therefore becomes H level. When the signals input from an input terminal (In) change from H level to L level, the capacitor 558 is used to reduce the electric potential of the output electrode of the TFT 553 once, as described in the Embodiment Mode.

Note the relationship between the TFT 551 and the TFT 552 is as follows: the gate electrode and the input electrode of the TFT 551 are connected, and therefore both the TFT 551 and the TFT 552 are in an on state when the TFT 552 turns on. It is necessary for the electric potential of the gate electrodes of the TFT 553 and 555 to become L level in this state, and therefore it is necessary to design the channel width of the TFT 551 to be smaller than that of the TFT 552. It is sufficient to have the capability for changing the gate electrodes of the TFT 553 and 555, and therefore the channel width of the TFT 551 may be set to a minimum value. Furthermore, it is possible to obtain no increase in electric current consumption in a period during which the TFT 552 is on, due to the penetration path among power supply VDD, the TFT 551, the TFT 552, and power supply VSS, by making the TFT 551 smaller.

FIG. 5C shows the structure of the unit (Buf Unit 2) used in the second and later stages. Input to the gate electrode of the TFT 562 is similar to that of the initial stage, and in addition, the previous stage input is used as an inverted input to the gate electrode of the TFT 561. The TFTs 561 and 562 are thus exclusively on and off, respectively, and the penetration path among power supply VDD, the TFT 561, the TFT 562, and power supply VSS can be eliminated in the structure of FIG. 5B.

FIG. 6 shows structures of a clock signal level shifter (CKLS) and a start pulse level shifter (SPLS) used in the display device of Embodiment 3. The basic structure has four stages, a level shifter for an initial stage, and buffers for the second and the following stages, which are similar to the aforementioned buffer circuits. A signal with the amplitude of $VDD_{LO} - VSS$ is input, and an output signal with amplitude of $VDD - VSS$ is obtained (where $|VDD_{LO}| < |VDD|$ here).

Regarding the clock signal level shifter, the initial stage is one input, one output type, while the second and the subsequent stages are two input, one output types. The mutual inputs are also used as inverted inputs.

The start pulse level shifter has a similar structure to that of the aforementioned buffer.

The circuit structure of the unit used for the initial stage of the level shifter is shown in FIG. 6C, while the circuit structure the unit used for the second and the subsequent stages is shown in FIG. 6D. The circuit structure and operation are similar to those shown in FIGS. 5B and 5C, respectively. The only difference is that the amplitude of the signal input to the initial stage is $VDD_{LO}-VSS$.

The TFT **652**, **654**, **656** turn on when the H level signal is input from an input terminal (IN) (in the case in which the absolute value $|VDD_{LO}-VSS|$ of the amplitude of the input signal is certainly greater than the absolute value $|V_{thN}|$ of the threshold value of the TFT **652**, **654**, **656**). The electric potential of gate electrodes of TFTs **653** and **654** is pulled down to the VSS side, and therefore L level appears at an output terminal (out). On the other hand, when the signal input to the gate electrode of the TFT **652** is L level, then the TFTs **652**, **654**, and **656** turn off, and the electric potential of the gate electrodes of the TFT **653** and **655** is pulled up to the VDD side, through the TFT **651**. Subsequent operations are similar to those of the aforementioned buffer.

This level shifter with the above structure has a characteristic that the input signal is not directly input to the gate electrode for controlling the TFT **651** connected to the high electric potential side (VDD side). Consequently, the electric potential of the gate electrodes of the TFTs **653** and **655** can be pulled up, no matter what the threshold value of the TFT **651** is, even if the amplitude of the input signal is small. A high amplitude transformation gain is therefore obtained.

FIG. 15 is a diagram showing the circuit structure of a gate signal line driver circuit. The gate signal line driver circuit has a level shifter **1501** used for start pulse, a level shifter **1502** used for a clock signal, a shift register **1503** and a buffer **1504**.

A gate side clock signal (G-CK), a gate side clock inverted signal (G-CKb), and a gate side start pulse (G-SP) are input to the gate signal line driver circuit. The input signals are input after undergoing amplitude transformation by level shifters **1501** and **1502**.

Note that the shift register **1503**, the buffer **1504**, the start pulse level shifter **1501**, and the clock signal level shifter **1502** are similar to those used in the source signal line driver circuit, and therefore an explanation of their structure and operation is omitted here.

The display device manufactured by using the driver circuit introduced here and pixels shown in Embodiment 2 is structured by only single polarity TFTs, and therefore a portion of a doping process during manufacturing can be eliminated. In addition, it becomes possible to reduce the number of photomasks. It is also possible to resolve the problem of an increase in current consumption due to an expanded signal amplitude by using circuits that apply the bootstrap method, as discussed above.

Embodiment 4

Although an example of a case in which the pixels and the driver circuits in the periphery are structured by using n-channel TFTs is explained in Embodiment 2, it is also possible to implement the present invention by using p-channel TFTs.

In the case of n-channel TFTs, impurity regions referred to a overlap regions are formed to overlap gate electrodes in order to control hot carrier degradation and the like. In contrast, there is little influence due to hot carrier degradation in the case of p-channel TFTs, and therefore it is not particularly necessary to form overlap regions. It is therefore possible to perform manufacturing by simpler process steps.

A base film **6002** is formed on an insulating substrate **6001** such as glass, island-shaped semiconductor layers **6003** to **6005**, a gate insulating film **6006**, and conductive layers **6007** and **6008** are then formed as shown in FIG. 16A in accordance with Embodiment 2. Although The conductive layers **6007** and **6008** are shown here as a laminate structure, a single layer structure may also be used without any particular problems.

Next, as shown in FIG. 16B, a mask **6009** is formed from resist, and a first etching process is performed. Anisotropic etching is performed in Embodiment 2 by utilizing selectivity due to the materials of the conductive layers with the laminate structure. However, it is not particularly necessary to form regions that become overlap regions here, and therefore normal etching may be performed. A region that becomes thinner by an amount on the order of 20 to 50 nm due to etching at this point is formed in the gate insulating film **6006**.

A first doping process for adding an impurity element that imparts p-type conductivity to the island shape semiconductor layers is performed next. Conductive layers **6010** to **6013** are used as masks against the impurity element, and the impurity regions **6014** to **6016** are formed in a self-aligning manner. Boron (B) and the like are typically used as the impurity element that imparts p-type conductivity. The impurity regions **6014** to **6016** are formed by an ion doping using diborane (B^2H_6) here, and the impurity concentration within the semiconductor layers is set from 2×10^{20} to 2×10^{21} atoms/cm³.

The resist mask is then removed, and the state of FIG. 16C is obtained. Manufacturing then continues in accordance with the steps from FIG. 8B onward in Embodiment 2.

Embodiment 5

Although a circuit shown in FIG. 18A has a similar structure to that of the inverter circuit shown in FIGS. 1A and 1B, electric potential applied to a gate electrode of a TFT **1801** is $VDD_{LO} (< VDD)$, and the amplitude of an input signal is from VDD_{LO} to VSS.

Operation is now explained. The electric potential of gate electrodes of TFTs **1803** and **1807** becomes H level to turn the TFTs **1803** and **1807** on when the H level is input to a first signal input portion (In). At the same time, L level is input to a second signal input portion (Inb). VDD_{LO} is input to the gate electrode of the TFT **1801** to turn the TFT **1801** on, and therefore the electric potential of gate electrodes of TFTs **1802** and **1806** becomes the L level to turn the TFTs **1802** and **1806** off. Thus, L level appears in a signal output portion (Out).

On the other hand, the electric potential of the gate electrode of the TFTs **1803** and **1807** becomes the L level to turn the TFTs **1803** and **1807** off when the L level is input to the first signal input portion (In).

Operation at the instant that the signal input to the first signal input portion (In) switches from the H level to the L level is explained here. The electric potential of the signal input to the first signal input portion (In) begins to fall from the H level, and the voltage between a gate and a source of the TFT **1803** and the voltage between a gate and a source of the TFT **1807** soon fall below the threshold value of the TFTs **1803** and **1807** to turn them off. At this time, output terminals of the TFTs **1803** and **1807** are placed in a floating state. In addition, the electric potential of the gate electrodes of the TFTs **1803** and **1807** continues to drop, and the electric potential of the output terminal of the TFT **1803** also drops as shown by ΔV_f in (ii) of FIG. 18B due to capacitive coupling by a capacitor **1805** between the gate electrode and the output terminal of the TFT **1803**.

On the other hand, the signal input to the second signal input portion (Inb) switches from the L level to the H level. The electric potential of the gate electrodes of the TFTs **1802** and **1806** therefore rises, and reaches $(VDD_{LO}-V_{thN})$ to be placed in a floating state.

The voltage between a gate and a source of the TFT **1802** and the voltage between a gate and a source of the TFT **1806** at this point become large than V_{thN} to turn the TFTs **1802** and **1806** on. The electric potential of output terminals of the TFTs **1802** and **1806** therefore rises.

Accompanying the increase in the electric potential of the output terminal of the TFT **1802** due to the capacitive coupling by the capacitor **1804** between the gate electrode and the output terminal of the TFT **1802**, the electric potential of the gate electrode of the TFT **1802** in the floating state rises again to $(VDD_{LO}-V_{thN}+\Delta V_f)$.

The electric potential of the gate electrode of the TFT **1806** therefore also rises to $(VDD_{LO}-V_{thN}+\Delta V_f)$ at the same time, and the H level at the signal output portion (Out) rises normally to VDD.

The circuit shown in FIG. **18A** obtains output with an amplitude from VDD to VSS for input of a signal with an amplitude between VDD_{LO} and VSS, and therefore can be used as a level shifter.

Embodiment 6

A method of manufacturing a light emitting device using light emitting elements such as EL elements in a pixel portion is explained in Embodiment 6.

In accordance with the manufacturing processes disclosed in Embodiment 2, films up through a first interlayer insulating film and a second interlayer insulating film are formed as shown in FIGS. **8A** and **8B**.

Contact holes are then opened as shown in FIG. **19A**. The contact holes are formed by using dry etching or wet etching in order to reach n-type impurity regions, source signal lines, gate signal lines, electric current supply lines, and gate electrodes, respectively.

Next, a transparent conductive film, typically ITO, is formed and patterned into a predetermined shape as an EL element anode **7001**. A laminate film made from Ti, Al containing Ti, and Ti is formed, and patterned into a predetermined shape to form wiring electrodes **7002** to **7005** and a pixel electrode **7006**. The film thickness of each of the laminate film may be set similarly to those of Embodiment 2. The pixel electrode **7006** is formed so as to overlap with the anode **7001** already formed and exhibit contact.

An insulating film containing silicon (typically a silicon oxide film) is formed next, an opening portion is formed in a location which is corresponding to the anode **7001** of the EL element, and a third interlayer insulating film **7007** is formed. A sidewall with a tapered shape can easily be formed here by using wet etching in forming the opening portion. Note that EL layer deterioration, cut step, and the like, which are caused by steps, become conspicuous problems in the case in which the sidewalls do not have a sufficiently smooth tapered shape, and it is therefore necessary to exert caution.

After an EL layer **7008** is formed next, an EL element cathode **7009** is formed from cesium (Cs) with a thickness equal to or less than 2 nm and silver (Ag) with a thickness equal to or less than 10 nm. Light generated in the EL layer is transmitted through the cathode **7009** to be emitted by making the film thickness of the cathode **7009** of the EL element extremely thin.

A protective film **7010** is formed next in order to protect the EL element. After work for attaching an FPC and the like is then performed, the light emitting device is complete.

The detailed structure of the EL element is the light emitting device shown in FIG. **19A** is shown in FIG. **19B** in Embodiment 6. The anode **7101** of the EL element is made from a transparent conductive film, typically ITO. Reference numeral **7102** denotes an EL layer containing a light emitting layer. The cathode of the EL element is made from a Cs film **7103** and an Ag film **7104** each having an extremely thin thickness. Reference numeral **7105** denotes a protective film.

Light generated in an EL layer **7102** is emitted in an upward direction after transmitting through the Cs film **7103** and the Ag film **7104** constituting the cathode by forming the cathode of the EL element with an extremely thin film thickness. That is, the surface area of the light emitting area is not overwhelmed by a region where TFTs are formed, and therefore an aperture ratio of nearly 100% can be achieved.

Embodiment 7

A manufacturing process of a light emitting device by a method that differs from Embodiment 6 is explained in Embodiment 7.

In accordance with the manufacturing process disclosed in Embodiment 2, films up through a first interlayer insulating film and a second interlayer insulating film are formed as shown in FIGS. **8A** and **8B**.

Contact holes are then opened as shown in FIG. **20A**. The contact holes are formed by using dry etching or wet etching in order to reach n-type impurity regions, source signal lines, gate signal lines, electric current supply lines, and gate electrodes, respectively.

Wirings **7201** to **7204** are then formed, and a pixel electrode **7205** which serves as an anode of an EL element is formed as a laminate film made from Ti, Al containing Ti, Ti, and, a transparent conductive film.

An insulating film containing silicon (typically a silicon oxide film) is formed next, an opening portion is formed in a location which is corresponding to the anode of the EL element, and a third interlayer insulating film **7206** is formed. A sidewall with a tapered shape can easily be formed here by using wet etching in forming the opening portion. Note that EL layer deterioration, cut step, and the like caused by steps become conspicuous problems in the case in which the sidewalls do not have a sufficiently smooth tapered shape, and it is therefore necessary to exert caution.

After an EL layer **7207** is formed next, an EL element cathode **7208** is formed from cesium (Cs) with a thickness equal to or less than 2 nm, and silver (Ag) with a thickness equal to or less than 10 nm. Light generated in the EL layer is transmitted through the cathode **7208** to be emitted by making the film thickness of the cathode **7208** the EL element extremely thin.

A protective film **7209** is formed next in order to protect the EL element. After work for attaching an FPC and the like is then performed, the light emitting device is complete.

The detailed structure of the EL element in the light emitting device shown in FIG. **20A** is shown in FIG. **20B**. The anode of the EL element is made from a metallic film **7301** which is a laminate film of Ti, Al containing Ti, and Ti, and a transparent conductive film **7302**, typically ITO. Reference numeral **7303** denotes an EL layer containing a light emitting layer. The cathode of the EL element is made from a Cs film **7304** and an Ag film **7305** each having an extremely thin thickness. Reference numeral **7306** denotes a protective film.

25

The light emitting device manufactured in accordance with Embodiment 7 has an advantage that an aperture ratio of nearly 100% can be achieved, similar to the display device disclosed in Embodiment 6. In addition, it is possible to perform patterning of the metallic film made from a laminate of Ti, Al containing Ti, Ti, and the transparent conductive film by using a common photomask in forming the wirings and the pixel electrode. It therefore becomes possible to reduce the number of photomasks and to simplify processing.

Embodiment 8

In the present invention, capacitor means formed in order to perform boot strap operations may utilize a capacitance between a gate and a source of a TFT, and the capacitor means may also be formed by a pair of electrodes of two materials selected from a wiring, a gate electrode, an active layer, and the like, and an insulating layer sandwiched between the pair of electrodes.

FIG. 21 shows a structure in which capacitor means 2154 and 2155 are formed similarly to TFTs. A source region and a drain region of a TFT are mutually connected to function as capacitor means in which a gate electrode and a channel forming region below are taken as an electrode pair and a gate insulating film is taken as an insulating film. In addition, the gate electrode and a wiring material connected to a source region and a drain region may be taken as an electrode pair, and an interlayer insulating film between the gate material and the wiring material may be taken as an insulating film to function as the capacitor means.

An example of a mask layout, in the case of manufacturing an actual circuit as the structure shown in FIG. 21, is shown in FIG. 22A. It is noted that electric power sources, signals input from respective input terminals, signals output from respective output terminals, reference numerals for TFTs, and the like all correspond to the circuit diagram shown in FIG. 21.

FIG. 22B is a diagram showing a cross sectional diagram of FIG. 22A cut along a line segment X-X'. The source regions and the drain regions of the respective TFTs are connected by a wiring material formed over the TFTs 2154 and 2155.

FIG. 22C shows a photograph of an actual circuit manufactured by using the mask layout shown in FIG. 22A. It is noted that reference numerals and other symbols used in the photograph correspond to those in FIG. 21 and FIG. 22A.

Embodiment 9

The present invention can be applied to fabrication of a display device used for various electronic devices. Such electronic devices include a portable information terminal (electronic notebook, mobile computer, cellular phone, etc.), a video camera, a digital camera, a personal computer, a television, cellular phone, and the like. FIG. 17 shows examples of those.

FIG. 17A shows a liquid crystal display device or an OLED display which is constituted by a housing 3001, a supporting stand 3002, a display portion 3003, and the like. The present invention can be applied to the fabrication of the display portion 3003.

FIG. 17B shows a video camera which is constituted by a main body 3011, a display portion 3012, an audio input portion 3013, and operation switch 3014, a battery 3015, an image receiving portion 3016, and the like. The present invention can be applied to the fabrication of the display portion 3012.

FIG. 17C shows a notebook personal computer which is constituted by a main body 3021, a housing 3022, a display

26

portion 3023, a keyboard 3024, and the like. The present invention can be applied to the fabrication of the display portion 3023.

FIG. 17D shows a portable information terminal which is constituted by a main body 3031, a stylus 3032, a display portion 3033, an operation button 3034, an external interface 3035, and the like. The present invention can be applied to the fabrication of the display portion 3033.

FIG. 17E shows a sound reproducing system, specifically an on-vehicle audio apparatus, which is constituted by a main body 3041, a display portion 3042, operation switches 3043 and 3044, and the like. The present invention can be applied to the fabrication of the display portion 3042. Additionally, although the on-vehicle audio apparatus is illustrated in this example, the invention can also be used for a portable or household audio apparatus.

FIG. 17F shows a digital camera which is constituted by a main body 3051, a display portion (A) 3052, an eyepiece portion 3053, an operation switch 3054, a display portion (B) 3055, a battery 3056, and the like. The present invention can be applied to the fabrication of the display portion (A) 3052 and the display portion (B) 3055.

FIG. 17G shows a cellular phone which is constituted by a main body 3061, an audio output portion 3062, an audio input portion 3063, a display portion 3064, an operation switch 3065, an antenna 3066, and the like. The present invention can be applied to the fabrication of the display portion 3064.

Note that, the examples set forth above are merely examples, and the present invention is not limited to these applications.

With the present invention, it becomes possible to construct a semiconductor device and a pixel portion by using single polarity TFTs.

Further, operational reliability can be increased and the surface area occupied by circuits can be reduced, by making the load driving ability very high as a buffer circuit used in a driver circuit.

In addition, when a display device is manufactured by using single polarity TFTs, it becomes possible to omit a portion of processing steps for adding impurities and to contribute to reducing the costs for manufacturing the display device.

What is claimed is:

[1. A semiconductor device comprising:

- 45 first and second transistors each comprising an input terminal electrically connected to a first electric power source;
- third and fourth transistors each comprising an input terminal electrically connected to a second electric power source;
- 50 a fifth transistor comprising an output terminal electrically connected to a gate electrode of the first transistor and a gate electrode of the second transistor;
- a first capacitor between a gate electrode of the first transistor and an output terminal of the first transistor; and
- a second capacitor between a gate electrode of the third transistor and an output terminal of the third transistor;
- wherein each of the first through the fifth transistors have the same conductivity type,
- 55 wherein an output terminal of the first transistor and an output terminal of the third transistor are electrically connected,
- wherein an output terminal of the second transistor and an output terminal of the fourth transistor are electrically connected.]

[2. A semiconductor device according to claim 1, wherein one of the first and second capacitor means is formed by:

two electrodes selected from the group consisting of an active layer, a gate electrode, and a wiring; and an insulating material between the two electrodes.]

[3. A semiconductor device according to claim 1, wherein electric potential of the second electric power source is less than electric potential of the first electric power source when the conductivity type is n-channel, and

wherein the electric potential of the second electric power source is more than the electric potential of the first electric power source when the conductivity type is p-channel.]

[4. A semiconductor device according to claim 1, wherein the semiconductor device comprises at least one selected from the group consisting of an inverter, a buffer, a level shifter, and an amplifier.]

[5. A semiconductor device according to claim 1, wherein the semiconductor device is incorporated into a display device comprising a liquid crystal element or an light emitting element.]

[6. A semiconductor device according to claim 1, wherein the semiconductor device is incorporated into an electronic device selected from the group consisting of a computer, a video camera, and a digital camera.]

[7. A semiconductor device comprising:

first and second transistors each comprising an input terminal electrically connected to a first electric power source;

third and fourth transistors each comprising an input terminal electrically connected to a second electric power source;

a fifth transistor comprising an input terminal electrically connected to the first electric power source or to a third electric power source and an output terminal electrically connected to a gate electrode of the first transistor and a gate electrode of the second transistor;

a sixth transistor comprising an input terminal electrically connected to the second electric power source and an output terminal electrically connected to the gate electrode of the first transistor and the gate electrode of the second transistor;

wherein each of the first through the sixth transistors have the same conductivity type,

wherein the output terminal of the first transistor and an output terminal of the third transistor are electrically connected, and

wherein an output terminal of the second transistor and an output terminal of the fourth transistor are electrically connected.]

[8. A semiconductor device according to claim 7, further comprising a capacitor between the gate electrode and an output terminal of the first transistor.]

[9. A semiconductor device according to claim 8, wherein the capacitor is formed by:

two electrodes selected from the group consisting of an active layer, a gate electrode, and a wiring; and an insulating material between the two electrodes.]

[10. A semiconductor device according to claim 7, further comprising a first capacitor between the gate electrode and an output terminal of the first transistor; and a second capacitor between a gate electrode and an output terminal of the third transistor.]

[11. A semiconductor device according to claim 10, wherein one of the first and second capacitor means is formed by:

two electrodes selected from the group consisting of an active layer, a gate electrode, and a wiring; and an insulating material between the two electrodes.]

[12. A semiconductor device according to claim 7, further comprising a first signal input portion for inputting a first signal to a gate electrode of the third transistor, a gate electrode of the fourth transistor, and a gate electrode of the sixth transistor;

a second signal input portion for inputting a second signal to a gate electrode of the fifth transistor; and

a signal output portion for outputting a third signal from an output terminal of the second transistor and an output terminal of the fourth transistor.]

[13. A semiconductor device according to claim 7, wherein electric potential of the second electric power source is less than electric potential of the first electric power source when the conductivity type is n-channel, and

wherein the electric potential of the second electric power source is more than the electric potential of the first electric power source when the conductivity type is p-channel.]

[14. A semiconductor device according to claim 7, wherein the semiconductor device comprises at least one selected from the group consisting of an inverter, a buffer, a level shifter, and an amplifier.]

[15. A semiconductor device according to claim 7, wherein the semiconductor device is incorporated into a display device comprising a liquid crystal element or an light emitting element.]

[16. A semiconductor device according to claim 7, wherein the semiconductor device is incorporated into an electronic device selected from the group consisting of a computer, a video camera, and a digital camera.]

[17. A semiconductor device comprising a pixel portion and a driver circuit, the driver circuit comprising:

first and second transistors each comprising an input terminal electrically connected to a first electric power source;

third and fourth transistors each comprising an input terminal electrically connected to a second electric power source;

a fifth transistor comprising an output terminal electrically connected to a gate electrode of the first transistor and a gate electrode of the second transistor;

a first capacitor between a gate electrode of the first transistor and an output terminal of the first transistor; and a second capacitor between a gate electrode of the third transistor and an output terminal of the third transistor;

wherein each of the first through the fifth transistors have the same conductivity type,

wherein an output terminal of the first transistor and an output terminal of the third transistor are electrically connected,

wherein an output terminal of the second transistor and an output terminal of the fourth transistor are electrically connected.]

[18. A semiconductor device according to claim 17, wherein one of the first and second capacitor means is formed by:

two electrodes selected from the group consisting of an active layer, a gate electrode, and a wiring; and an insulating material between the two electrodes.]

29

[19. A semiconductor device according to claim 17, wherein electric potential of the second electric power source is less than electric potential of the first electric power source when the conductivity type is n-channel, and

wherein the electric potential of the second electric power source is more than the electric potential of the first electric power source when the conductivity type is p-channel.]

[20. A semiconductor device according to claim 17, wherein the semiconductor device comprises at least one selected from the group consisting of an inverter, a buffer, a level shifter, and an amplifier.]

[21. A semiconductor device according to claim 17, wherein the semiconductor device is a display device comprising a liquid crystal element or an light emitting element.]

[22. A semiconductor device according to claim 17, wherein the semiconductor device is an electronic device selected from the group consisting of a computer, a video camera, and a digital camera.]

[23. A semiconductor device comprising a pixel portion and a driver circuit, the driver circuit comprising:

first and second transistors each comprising an input terminal electrically connected to a first electric power source;

third and fourth transistors each comprising an input terminal electrically connected to a second electric power source;

a fifth transistor comprising an input terminal electrically connected to the first electric power source or to a third electric power source and an output terminal electrically connected to a gate electrode of the first transistor and a gate electrode of the second transistor;

a sixth transistor comprising an input terminal electrically connected to the second electric power source and an output terminal electrically connected to the gate electrode of the first transistor and the gate electrode of the second transistor;

wherein each of the first through the sixth transistors have the same conductivity type,

wherein the output terminal of the first transistor and an output terminal of the third transistor are electrically connected, and

wherein an output terminal of the second transistor and an output terminal of the fourth transistor are electrically connected.]

[24. A semiconductor device according to claim 23, further comprising a capacitor between the gate electrode and an output terminal of the first transistor.]

[25. A semiconductor device according to claim 24, wherein the capacitor is formed by:

two electrodes selected from the group consisting of an active layer, a gate electrode, and a wiring; and an insulating material between the two electrodes.]

[26. A semiconductor device according to claim 23, further comprising a first capacitor between the gate electrode and an output terminal of the first transistor; and a second capacitor between a gate electrode and an output terminal of the third transistor.]

[27. A semiconductor device according to claim 26, wherein one of the first and second capacitor means is formed by:

two electrodes selected from the group consisting of an active layer, a gate electrode, and a wiring; and an insulating material between the two electrodes.]

[28. A semiconductor device according to claim 23, further comprising a first signal input portion for inputting a first

30

signal to a gate electrode of the third transistor, a gate electrode of the fourth transistor, and a gate electrode of the sixth transistor;

a second signal input portion for inputting a second signal to a gate electrode of the fifth transistor; and

a signal output portion for outputting a third signal from an output terminal of the second transistor and an output terminal of the fourth transistor.]

[29. A semiconductor device according to claim 23, wherein electric potential of the second electric power source is less than electric potential of the first electric power source when the conductivity type is n-channel, and

wherein the electric potential of the second electric power source is more than the electric potential of the first electric power source when the conductivity type is p-channel.]

[30. A semiconductor device according to claim 23, wherein the semiconductor device comprises at least one selected from the group consisting of an inverter, a buffer, a level shifter, and an amplifier.]

[31. A semiconductor device according to claim 23, wherein the semiconductor device is a display device comprising a liquid crystal element or an light emitting element.]

[32. A semiconductor device according to claim 23, wherein the semiconductor device is an electronic device selected from the group consisting of a computer, a video camera, and a digital camera.]

33. *A display device comprising:*

a pixel portion over a first substrate;

a gate signal line driver circuit over the first substrate, the gate signal line driver circuit comprising:

first and second thin film transistors each comprising one of source and drain electrically connected to each other,

third and fourth thin film transistors each comprising a gate electrically connected to each other,

a fifth thin film transistor comprising another one of source and drain electrically connected to a gate of the first thin film transistor and a gate of the second thin film transistor,

a sixth thin film transistor comprising another one of source and drain electrically connected to the gate of the first thin film transistor and the gate of the second thin film transistor, and

a capacitor between a gate of the first thin film transistor and another one of source and drain of the first thin film transistor,

wherein the first through the sixth thin film transistors have the same conductivity type, and

wherein the another one of source and drain of the first thin film transistor and another one of source and drain of the third thin film transistor are electrically connected to each other;

a second substrate opposed to the first substrate with a sealant interposed therebetween; and

a liquid crystal provided in a space enclosed by the first substrate, the second substrate and the sealant,

wherein the gate signal line driver circuit is overlapped with the liquid crystal.

34. *A display device according to claim 33, wherein another one of source and drain of the second thin film transistor and another one of source and drain of the fourth thin film transistor are electrically connected to each other.*

35. *A display device according to claim 33, wherein the one of source and drain of the first thin film transistor and the one*

31

of source and drain of the second thin film transistor are electrically connected to a first electric power source.

36. A display device according to claim 33, wherein the third and fourth thin film transistors each comprise one of source and drain electrically connected to a second electric power source.

37. A display device according to claim 33 further comprising a second capacitor between a gate of the third thin film transistor and the another one of source and drain of the third thin film transistor.

38. A display device according to claim 33, wherein the display device is incorporated into an electronic device selected from the group consisting of a computer, a video camera, and a digital camera.

39. A display device comprising:

a pixel portion over a first substrate;

a source signal line driver circuit over the first substrate, the source signal line driver circuit comprising:

first and second thin film transistors each comprising one of source and drain electrically connected to each other;

third and fourth thin film transistors each comprising a gate electrically connected to each other;

a fifth thin film transistor comprising another one of source and drain electrically connected to a gate of the first thin film transistor and a gate of the second thin film transistor;

a sixth thin film transistor comprising another one of source and drain electrically connected to the gate of the first thin film transistor and the gate of the second thin film transistor; and

a capacitor between a gate of the first thin film transistor and another one of source and drain of the first thin film transistor;

wherein the first through the sixth thin film transistors have the same conductivity type, and

wherein the another one of source and drain of the first thin film transistor and another one of source and drain of the third thin film transistor are electrically connected to each other;

a second substrate opposed to the first substrate with a sealant interposed therebetween; and

a liquid crystal provided in a space enclosed by the first substrate, the second substrate and the sealant, wherein the source signal line driver circuit is overlapped with the liquid crystal.

40. A display device according to claim 39, wherein another one of source and drain of the second thin film transistor and another one of source and drain of the fourth thin film transistor are electrically connected to each other.

41. A display device according to claim 39, wherein the one of source and drain of the first thin film transistor and the one of source and drain of the second thin film transistor are electrically connected to a first electric power source.

42. A display device according to claim 39, wherein the third and fourth thin film transistors each comprise one of source and drain electrically connected to a second electric power source.

43. A display device according to claim 39 further comprising a second capacitor between a gate of the third thin film transistor and the another one of source and drain of the third thin film transistor.

44. A display device according to claim 39, wherein the display device is incorporated into an electronic device selected from the group consisting of a computer, a video camera, and a digital camera.

32

45. A display device comprising:

a pixel portion over a first substrate;

a gate signal line driver circuit over the first substrate, the gate signal line driver circuit comprising:

first and second thin film transistors each comprising one of source and drain electrically connected to each other;

third and fourth thin film transistors each comprising a gate electrically connected to each other;

a fifth thin film transistor comprising another one of source and drain electrically connected to a gate of the first thin film transistor and a gate of the second thin film transistor; and

a capacitor between a gate of the first thin film transistor and another one of source and drain of the first thin film transistor;

wherein the first through the fifth thin film transistors have the same conductivity type, and

wherein the another one of source and drain of the first thin film transistor and another one of source and drain of the third thin film transistor are electrically connected to each other;

a second substrate opposed to the first substrate with a sealant interposed therebetween; and

a liquid crystal provided in a space enclosed by the first substrate, the second substrate and the sealant, wherein the gate signal line driver circuit is overlapped with the liquid crystal.

46. A display device according to claim 45, wherein another one of source and drain of the second thin film transistor and another one of source and drain of the fourth thin film transistor are electrically connected to each other.

47. A display device according to claim 45, wherein the one of source and drain of the first thin film transistor and the one of source and drain of the second thin film transistor are electrically connected to a first electric power source.

48. A display device according to claim 45, wherein the third and fourth thin film transistors each comprise one of source and drain electrically connected to a second electric power source.

49. A display device according to claim 45 further comprising a second capacitor between a gate of the third thin film transistor and the another one of source and drain of the third thin film transistor.

50. A display device according to claim 45, wherein the display device is incorporated into an electronic device selected from the group consisting of a computer, a video camera, and a digital camera.

51. A display device comprising:

a pixel portion over a first substrate;

a source signal line driver circuit over the first substrate, the source signal line driver circuit comprising:

first and second thin film transistors each comprising one of source and drain electrically connected to each other;

third and fourth thin film transistors each comprising a gate electrically connected to each other;

a fifth thin film transistor comprising another one of source and drain electrically connected to a gate of the first thin film transistor and a gate of the second thin film transistor; and

a capacitor between a gate of the first thin film transistor and another one of source and drain of the first thin film transistor;

wherein the first through the fifth thin film transistors have the same conductivity type, and

wherein the another one of source and drain of the first thin film transistor and another one of source and drain of the third thin film transistor are electrically connected to each other;

a second substrate opposed to the first substrate with a sealant interposed therebetween; and

a liquid crystal provided in a space enclosed by the first substrate, the second substrate and the sealant, wherein the source signal line driver circuit is overlapped with the liquid crystal.

52. A display device according to claim 51, wherein another one of source and drain of the second thin film transistor and another one of source and drain of the fourth thin film transistor are electrically connected to each other.

53. A display device according to claim 51, wherein the one of source and drain of the first thin film transistor and the one of source and drain of the second thin film transistor are electrically connected to a first electric power source.

54. A display device according to claim 51, wherein the third and fourth thin film transistors each comprise one of source and drain electrically connected to a second electric power source.

55. A display device according to claim 51 further comprising a second capacitor between a gate of the third thin film transistor and the another one of source and drain of the third thin film transistor.

56. A display device according to claim 51, wherein the display device is incorporated into an electronic device selected from the group consisting of a computer, a video camera, and a digital camera.

* * * * *

UNITED STATES PATENT AND TRADEMARK OFFICE
CERTIFICATE OF CORRECTION

PATENT NO. : RE44,657 E
APPLICATION NO. : 13/471870
DATED : December 24, 2013
INVENTOR(S) : Hiroyuki Miyake and Yutaka Shionoiri

Page 1 of 3

It is certified that error appears in the above-identified patent and that said Letters Patent is hereby corrected as shown below:

In the Specification

Column 1, line 43, replace “register” with --registers--;

Column 2, line 9, replace “state” with --stage--;

Column 3, line 29, after “on” insert --and--;

Column 3, line 38, replace “beings” with --begins--;

Column 3, line 49, replace “Input” with --input--;

Column 4, line 43, replace “number” with --numeral--;

Column 4, line 61, after “time” insert --may--;

Column 5, line 18, replace “electric” with --electrical--;

Column 5, line 19, after “structure,” replace “iT” with --it--;

Column 5, line 27, before “the like” replace “an” with --and--;

Column 5, line 39, before “fluctuation” insert --the--;

Column 5, line 45, replace “therefor” with --therefore--;

Column 6, line 13, after “transistor” replace “,” with --;--;

Column 6, line 18, after “transistor” replace “,” with --;--;

Column 6, line 55, after “transistor” replace “,” with --;--;

Column 7, line 61, after “transistor” replace “,” with --;--;

Signed and Sealed this
Second Day of September, 2014



Michelle K. Lee
Deputy Director of the United States Patent and Trademark Office

U.S. Pat. No. RE44,657 E

Column 8, line 31, after “transistor” replace “,” with --;--;

Column 8, line 38, after “transistor” replace “,” with --;--;

Column 9, line 5, before “n-channel” delete “a”;

Column 10, line 39, after “TFT” insert --153--;

Column 10, line 55, before “electric” replace “the” with --The--;

Column 11, line 16, after “2A” replace “and” with --to--;

Column 11, line 46, replace “153G” with --V153G--;

Column 12, line 37, replace “turns” with --turn--;

Column 12, line 61, after “manufacturing” insert --of--;

Column 12, line 63, replace “not” with --no--;

Column 13, line 4, replace “now” with --not--;

Column 13, line 35, replace “beam” with --beams--;

Column 14, line 13, after “sputtering” insert --,--;

Column 14, line 44, replace “films” with --film--;

Column 14, line 50, replace “radio” with --ratio--;

Column 14, line 60, replace “an” with --and--;

Column 15, line 3, replace “n-type” with --N-type--;

Column 15, line 21, replace “number” with --numeral--;

Column 15, line 31, after “pressure” insert --of--;

Column 15, line 34, before “appropriate” insert --an--;

Column 15, line 41, replace “oxidation” with --oxidization--;

Column 15, line 52, replace “KeV” with --keV--;

Column 16, line 57, replace “now” with --not--;

Column 17, line 15, replace “SE7992” with --SE7792--;

Column 17, line 25, replace “now” with --not--;

Column 17, line 52, after “crystal” insert --display--;

Column 17, line 55, replace “patter” with --pattern--;

Column 18, line 9, after “circuit” insert --formed--;

Column 18, line 20, replace “now” with --not--;

Column 18, line 29, replace “filter” with --filler--;

Column 18, line 33, replace “substrata” with --substrate--;

Column 18, line 57, replace “(K-1) th” with --(k-1)-th--;

Column 19, line 4, after “401” insert --and 404--;

Column 19, line 5, replace “number” with --numeral--;

Column 19, line 36, replace “number” with --numeral--;

Column 19, lines 49-50, before “406 becomes” insert --TFT--;

Column 20, line 32, after “Note” insert --that--;

Column 20, line 40, replace “changing” with --charging--;

Column 20, line 47, replace “Bud” with --Buf--;

Column 20, line 64, after “stage is” insert --a--;

Column 21, line 8, replace “to” with --in--;

Column 21, line 62, replace “a” with --as--;

Column 22, line 24, before “ion” delete “an”;

Column 22, line 35, replace “sown” with --shown--;

Column 22, lines 49-50, replace “electrode” with --electrodes--;

Column 23, line 8, replace “large” with --larger--;

Column 24, line 4, after “element” replace “is” with --in--;

Column 24, line 39, after “and” delete “,”;

Column 25, line 62, replace “and” with --an--;

Column 26, line 22, replace “(13)” with --(B)--.