

US00RE44568E

(19) **United States**
(12) **Reissued Patent**
Stepp

(10) **Patent Number:** **US RE44,568 E**
(45) **Date of Reissued Patent:** **Nov. 5, 2013**

(54) **GUN SAFE DOOR STORAGE SYSTEM**
(75) Inventor: **Richard E. Stepp**, Springville, UT (US)
(73) Assignee: **Prosteel Security Products, Inc.**, Provo, UT (US)
(21) Appl. No.: **12/854,762**

3,997,219 A 12/1976 Phelps
4,057,180 A 11/1977 Whittaker
4,095,860 A 6/1978 Henson
4,099,808 A 7/1978 Oakley
4,197,951 A 4/1980 Shassere
4,236,772 A 12/1980 Henson
4,304,447 A 12/1981 Ellwood
4,396,240 A 8/1983 Henson

(Continued)

(22) Filed: **Aug. 11, 2010**

FOREIGN PATENT DOCUMENTS

EP 0962731 12/1999

Related U.S. Patent Documents

Reissue of:

(64) Patent No.: **7,409,790**
Issued: **Aug. 12, 2008**
Appl. No.: **11/674,484**
Filed: **Feb. 13, 2007**

OTHER PUBLICATIONS

Photographs from 2002 Shooting, Hunting, Outdoor Trade Show and Conference ("SHOT Show"—Owned and Sponsored by National Shooting Sports Foundation), DPMS safe on p. 5 of 6.

(Continued)

U.S. Applications:

(63) Continuation-in-part of application No. 10/971,584, filed on Oct. 22, 2004, now Pat. No. 7,877,920.
(60) Provisional application No. 60/513,967, filed on Oct. 24, 2003.

Primary Examiner — J. Woodrow Eldred

(74) *Attorney, Agent, or Firm* — Ostrager Chong Flaherty & Broitman P.C.

(51) **Int. Cl.**
F41A 17/00 (2006.01)
A47F 7/00 (2006.01)

(57) **ABSTRACT**

(52) **U.S. Cl.**
USPC **42/70.01**; 42/70.11; 211/4; 211/64;
109/51; 109/50; 206/315.11

A gun safe door storage system is permanently affixed to an interior surface of a gun safe door. The door storage system comprises a plurality of integrated pouches or pockets and a rack arranged such that the pouches or pockets are accessible even when the rack is holding rifles or rifle parts, such as barrels. Substantially all of the available space on the interior surface of the door is filled with pockets or pouches. The pouches or pockets are affixed to a backing material having strength and weight sufficient to prevent sagging. The backing material is permanently affixed to the interior surface of the gun safe door. The rack comprises a barrel support and a stock support mounted permanently on the interior surface of the gun safe door over the pouches or pockets.

(58) **Field of Classification Search**
USPC 42/70.1, 70.11; 211/4, 64; 109/51;
206/315.11

See application file for complete search history.

(56) **References Cited**

U.S. PATENT DOCUMENTS

3,421,632 A 1/1969 Wood
3,822,925 A 7/1974 Osroff
3,918,670 A 11/1975 Doherty

33 Claims, 6 Drawing Sheets

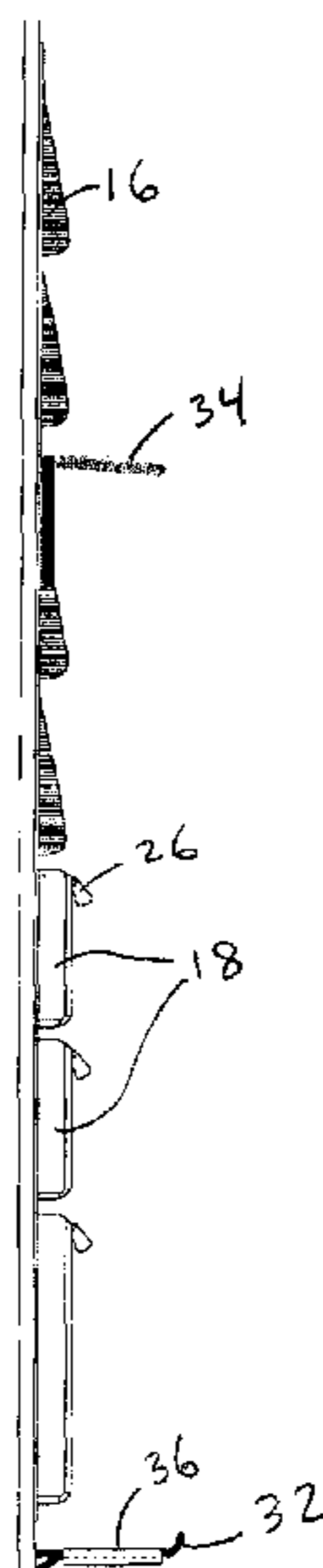

(56)

References Cited

U.S. PATENT DOCUMENTS

4,502,742 A 3/1985 Neff
 4,585,127 A 4/1986 Benedict
 D287,550 S 1/1987 Tocchi
 4,776,650 A 10/1988 Ferenzi
 4,796,762 A 1/1989 Law
 D300,398 S 3/1989 Krugman
 4,859,084 A 8/1989 Kaumeyer
 D305,153 S 12/1989 Elderkin
 4,949,843 A 8/1990 Stokes
 4,953,765 A 9/1990 Little
 4,978,001 A 12/1990 Nelson
 4,986,427 A 1/1991 Law
 5,076,442 A 12/1991 Hakeem
 5,078,279 A 1/1992 Hancock
 5,158,186 A 10/1992 Krut
 5,163,745 A 11/1992 Zagata
 D335,233 S 5/1993 Long
 D337,467 S 7/1993 Schmidt
 5,246,103 A 9/1993 Hicks
 D343,970 S 2/1994 Campbell
 5,282,539 A 2/1994 Saathoff
 D354,412 S 1/1995 Emery
 5,477,967 A 12/1995 Voorhees
 5,495,969 A 3/1996 Cardenas
 5,511,873 A 4/1996 Mech
 5,626,379 A 5/1997 Scott
 5,645,178 A 7/1997 Conley, Jr.
 5,685,624 A 11/1997 Lee
 5,695,073 A 12/1997 Klein
 5,758,936 A 6/1998 Baughan
 5,797,500 A 8/1998 Lacoste
 5,887,730 A 3/1999 St. George
 5,894,940 A 4/1999 Gusdorf
 5,957,308 A 9/1999 Zierenberg
 6,042,207 A 3/2000 Crosby
 D429,897 S 8/2000 Rogman
 D429,938 S 8/2000 Allen
 6,098,815 A 8/2000 Nesser
 6,126,021 A 10/2000 Wilhite
 6,138,841 A 10/2000 Klein
 6,238,030 B1 5/2001 Matselboba
 6,302,052 B1 10/2001 Sauerwein
 6,361,130 B1 3/2002 Kardy
 6,386,379 B1 5/2002 Battaglia
 6,394,287 B2 5/2002 Cabrera
 6,464,086 B1 10/2002 Klein
 6,467,613 B2 10/2002 Felsenthal

6,533,127 B1 3/2003 Klein
 6,581,786 B1 6/2003 King
 D499,286 S 12/2004 Harwanko
 D501,106 S 1/2005 Suero, Jr.
 6,857,528 B2 2/2005 Klein
 6,868,975 B2 3/2005 Sells
 6,997,526 B2 2/2006 Leimkuehler
 7,198,835 B2 4/2007 Anderson
 7,478,892 B2 1/2009 Punzel
 2003/0011291 A1 1/2003 Moreno-Olguin
 2003/0085188 A1 5/2003 Klein
 2003/0213720 A1 11/2003 Nesselrodt
 2004/0124116 A1 7/2004 Long
 2004/0130250 A1 7/2004 Cleveland
 2004/0140235 A1 7/2004 Cleveland
 2004/0140280 A1 7/2004 Cleveland
 2004/0183416 A1 9/2004 Becke
 2004/0222125 A1 11/2004 Meing
 2005/0133473 A1 6/2005 Lesperance
 2006/0186071 A1 8/2006 Rowan
 2006/0186775 A1 8/2006 Becke

OTHER PUBLICATIONS

Heritage Safe Co. 1999 Brochure, page displaying safes and inside of safes.
 Buckmasters Online Magazine, "New Products," web page url <http://www.buckmasters.com/Buckmasters_Links/New_Products/NPSentryRU9889.html>, p. 1, printout dated Oct. 18, 2004.
 Liberty Safe, "About Liberty Safe," web page url <<http://www.libertysafe.com/about.lasso?-Token.link=4in1flex>>, p. 1, printout dated Oct. 18, 2004.
 Arizona Safe Keeper, "Gun Safe Accessories," web page url <<http://www.arizonasafekeeper.com/skpistol.html>>, p. 1, printout dated Oct. 18, 2004.
 Sentry Group, "Gun Safe/Executive Safe Owner's Manual," web page url <<http://www.sentrysafe.com/pdfs/ownersmanuals/172752.pdf>>.
 Browning, "G28F Gold Series Gun Safe with "Duo-Plus"," web page url <http://browning.com/products/catalog/safes/detail.asp?cat_id=160&type_id=42741&value=001F>, printout dated Feb. 5, 2007, manufactured by ProSteel, the Assignee herein.
 Browning, "Safe-hold System Accessories," web page url <http://www.browning.com/products/catalog/safes/detail.asp?cat_id=154&type_id=401&value=004F> printout dated Feb. 5, 2007.
 Cannon Safe, "Door Panel Pistol Kit," web page url <<http://www.cannonsafe.com/safespecialorder/>>, printout dated Feb. 4, 2007.
 Liberty Safe, "Door-Mounted Pistol Pockets," web page url <[http://www.libertysafe.com/accessory.lasso?type=pistol pocket](http://www.libertysafe.com/accessory.lasso?type=pistol%20pocket)>, printout dated Feb. 4, 2007.

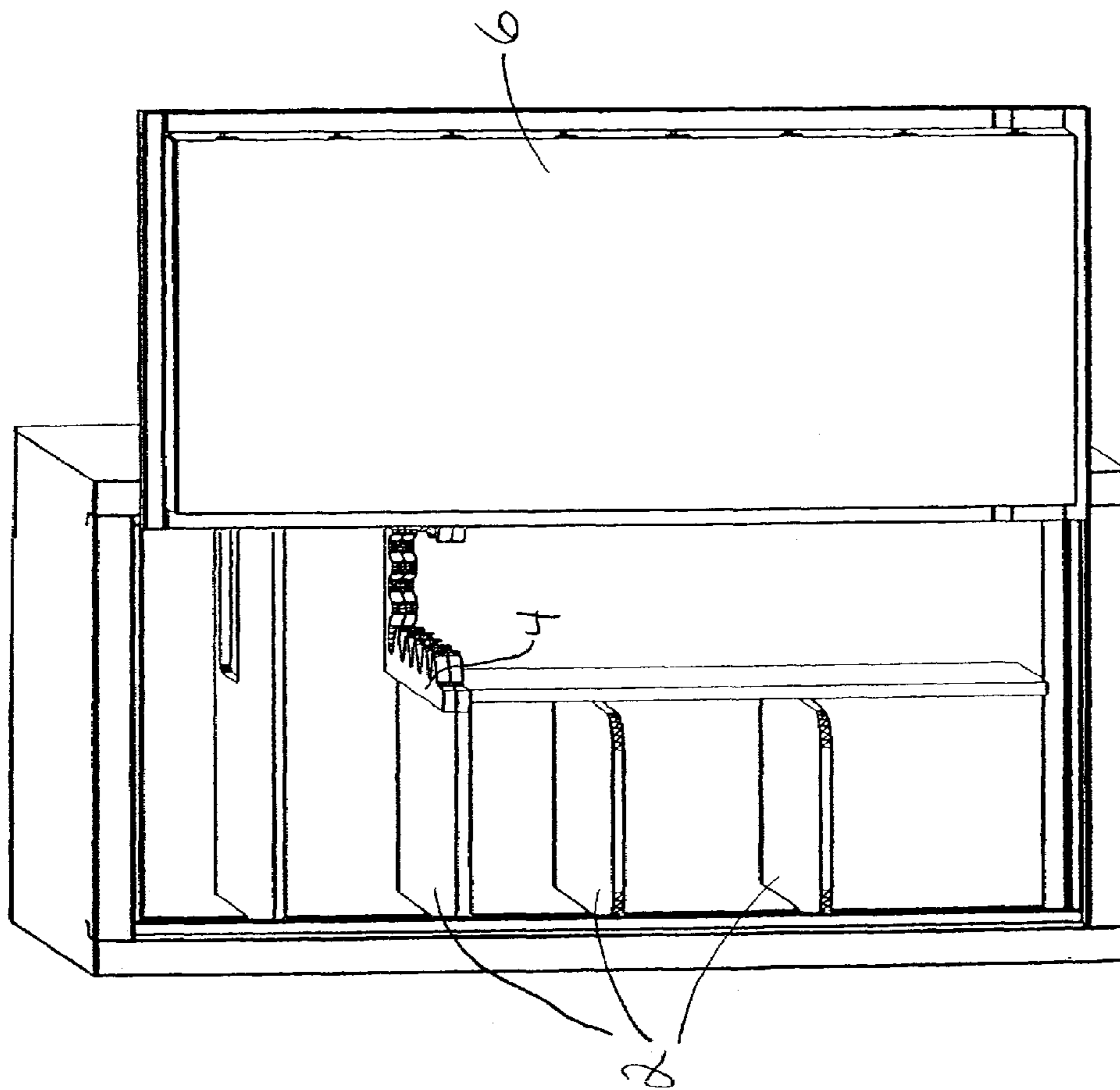

FIG. 1
(PRIOR ART)

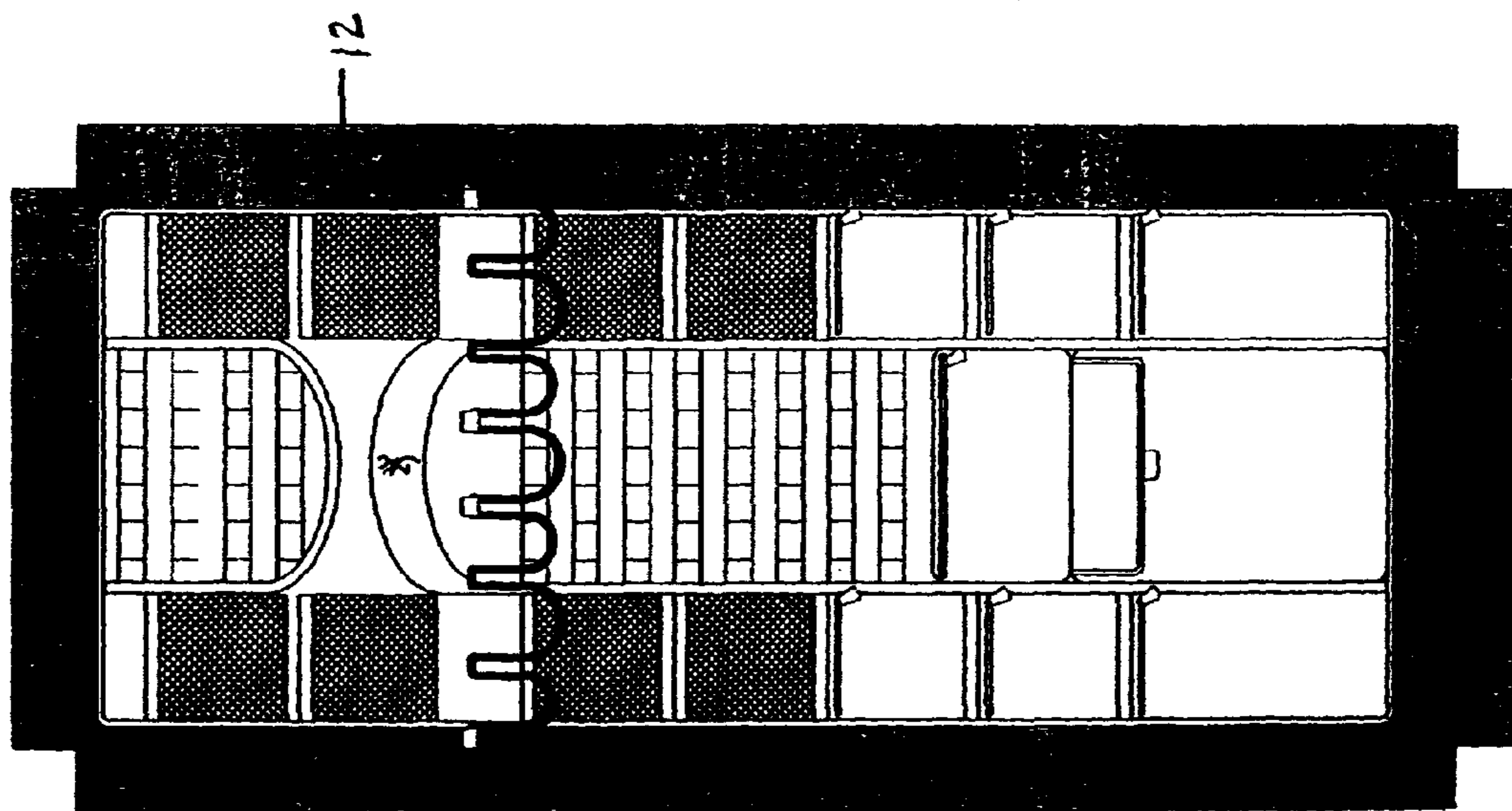

FIG. 2

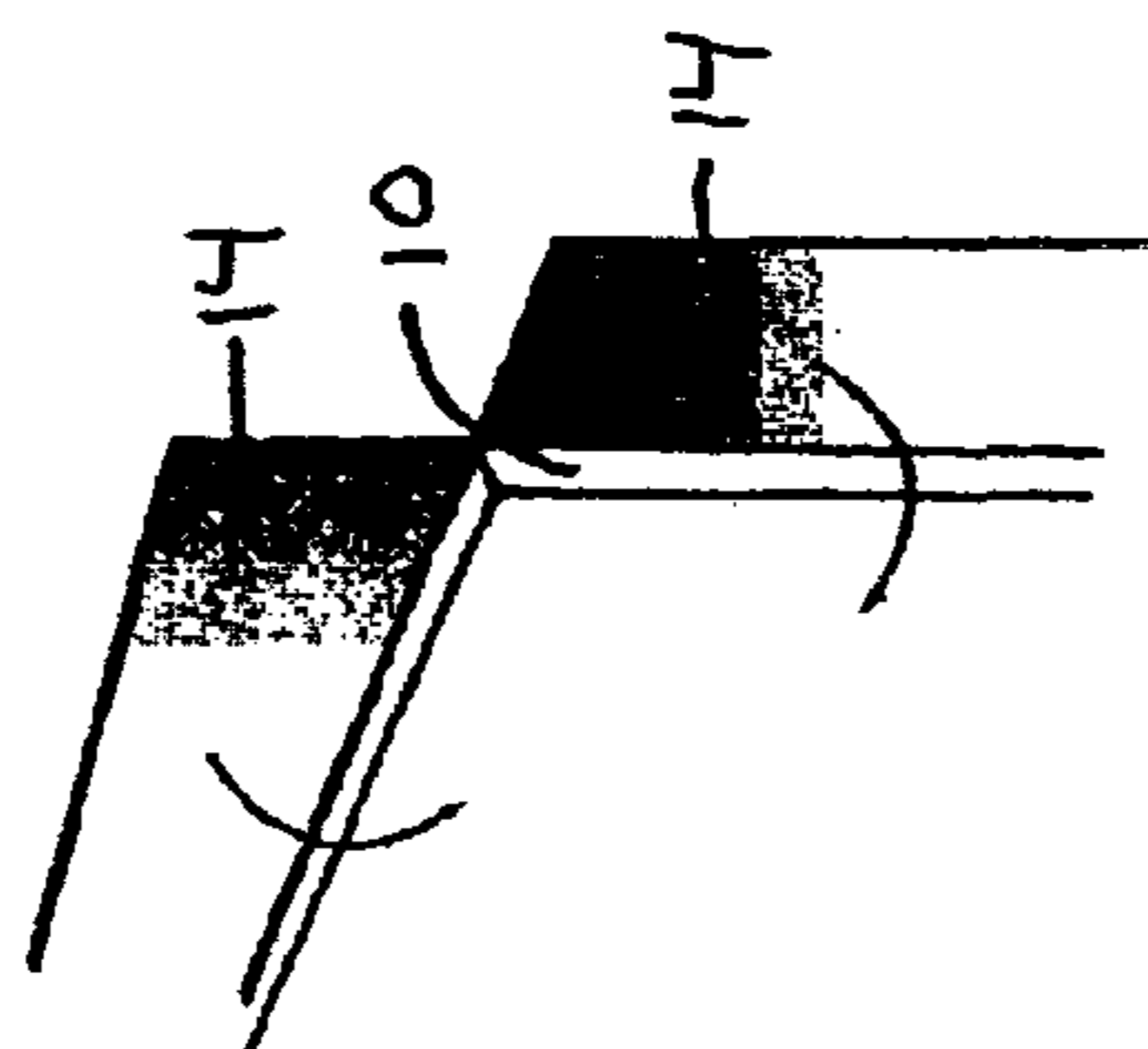

FIG. 3

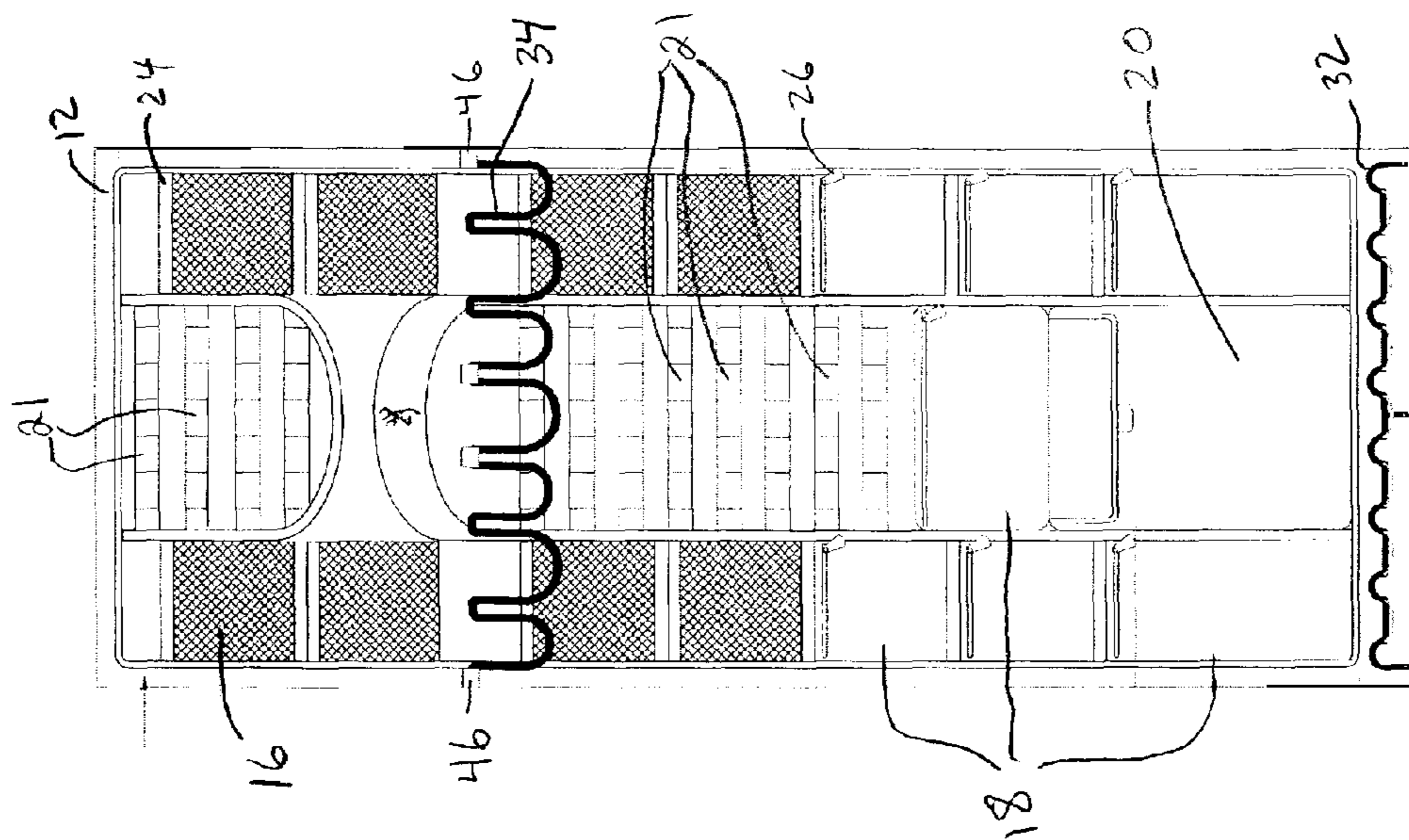

FIG. 4

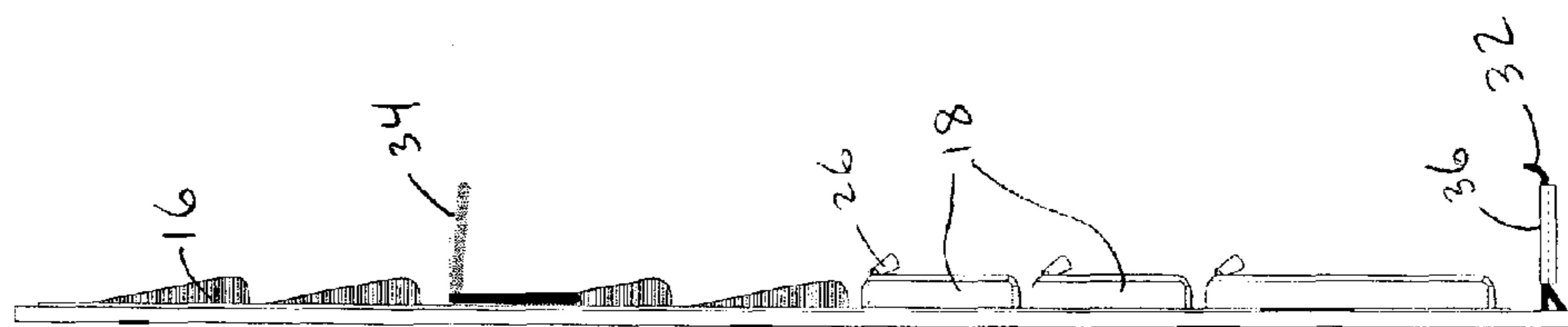

FIG. 5

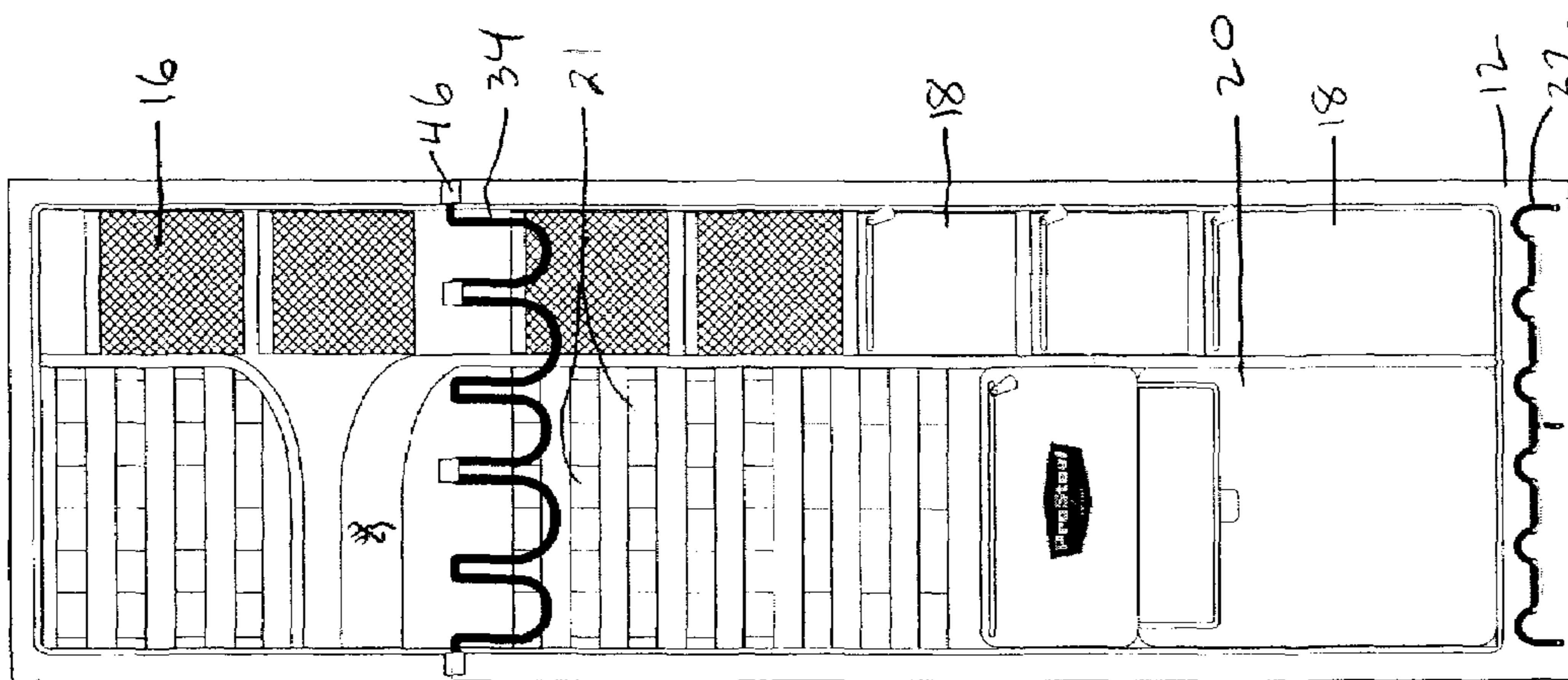

FIG. 6

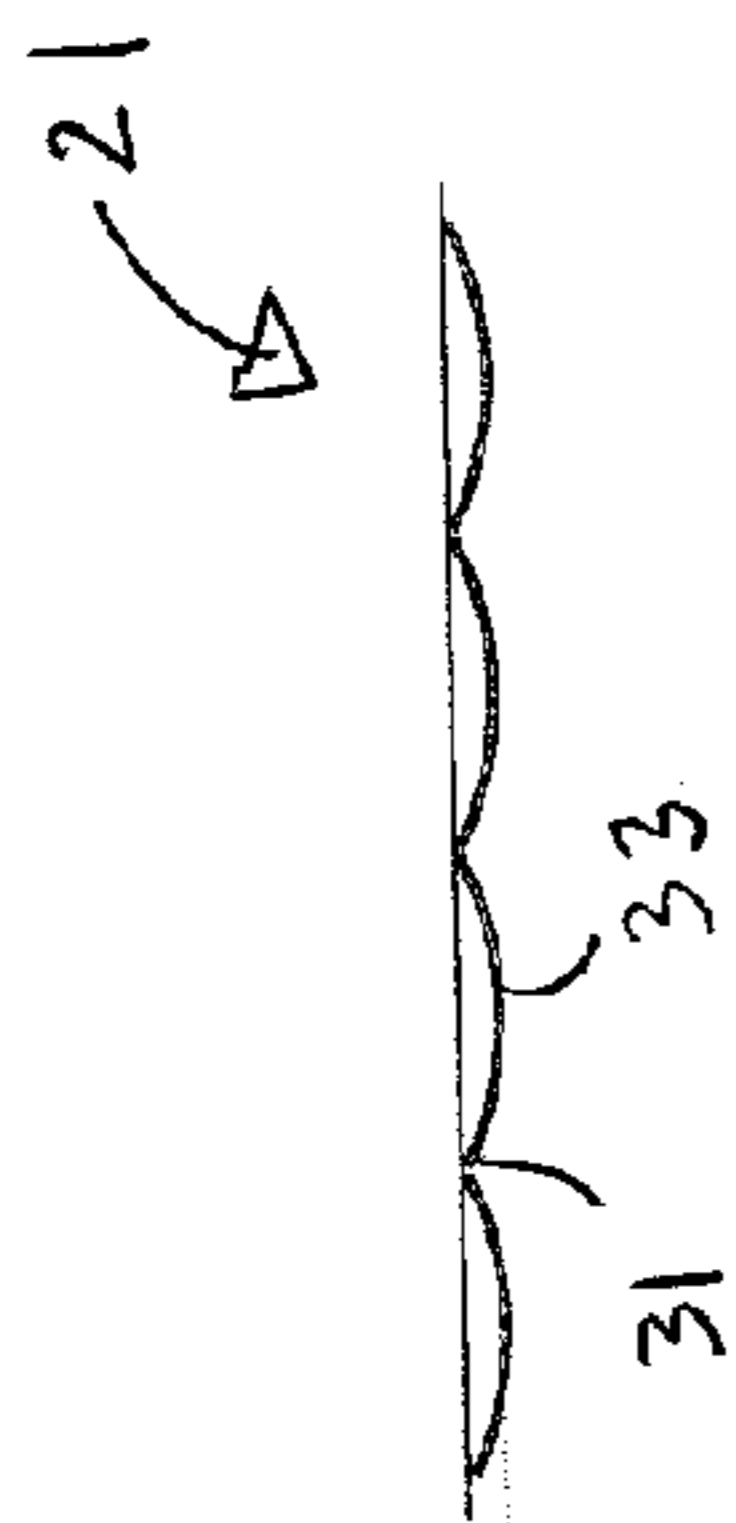

FIG. 8

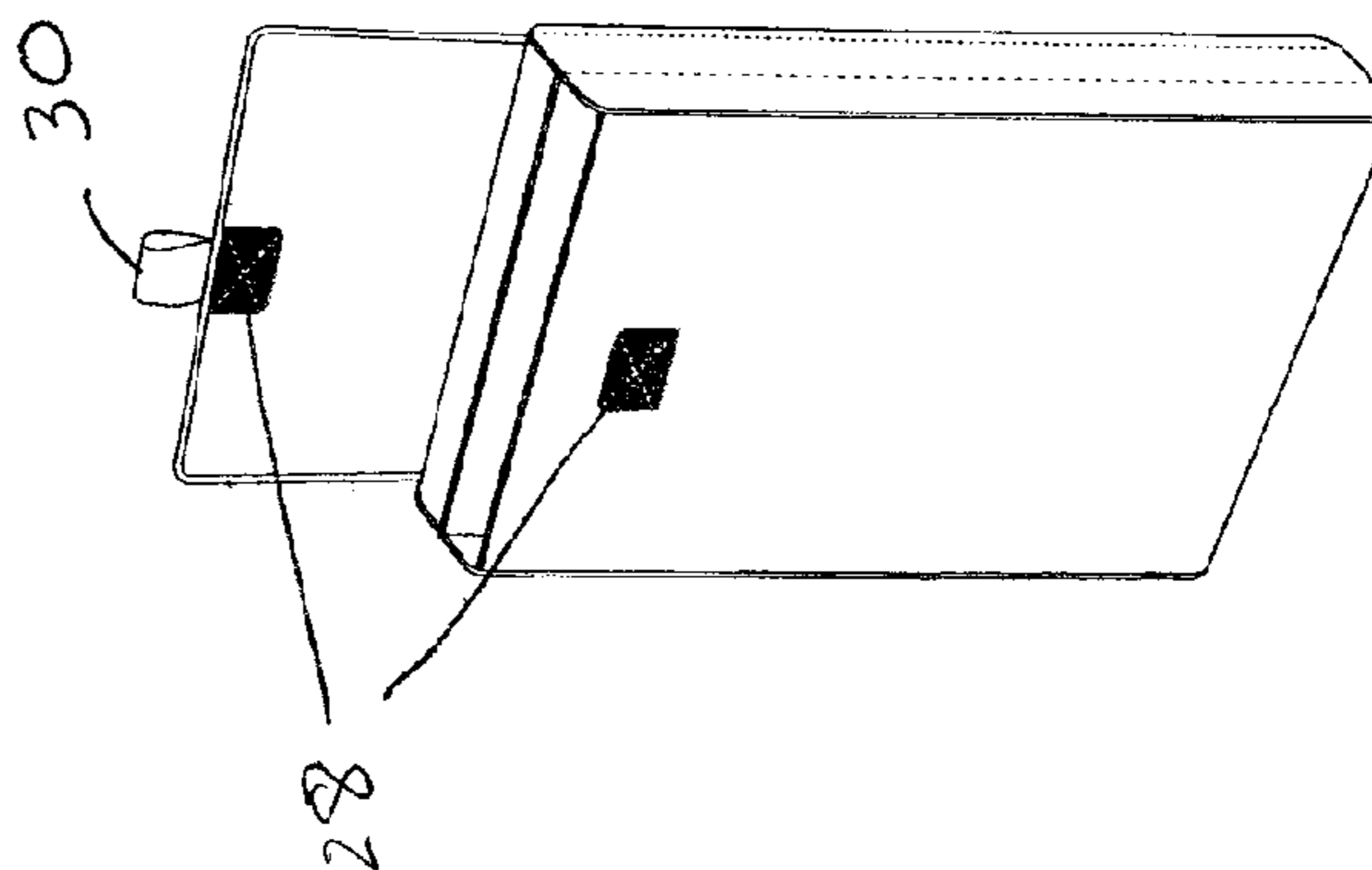

FIG. 7A

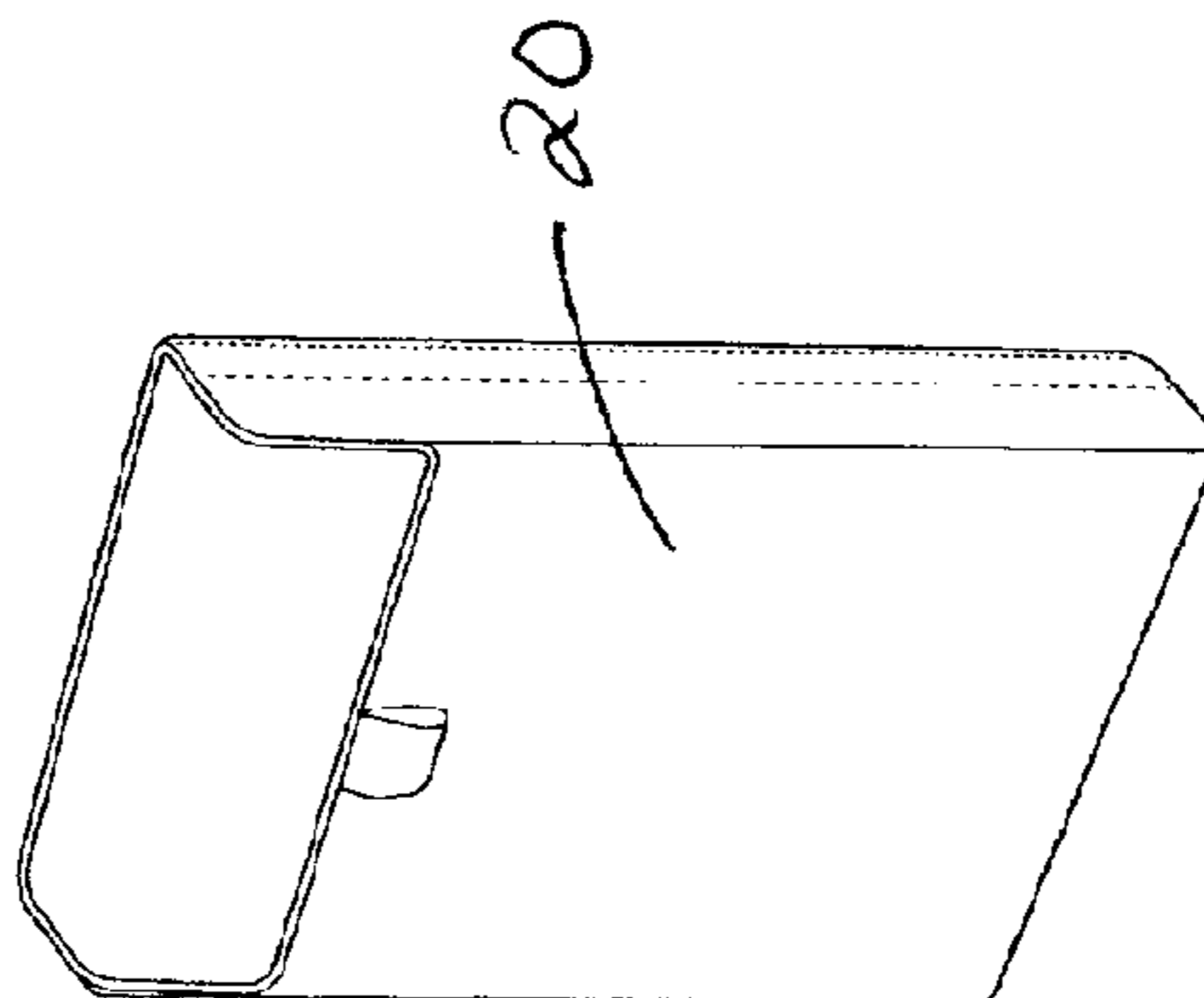

FIG. 7B

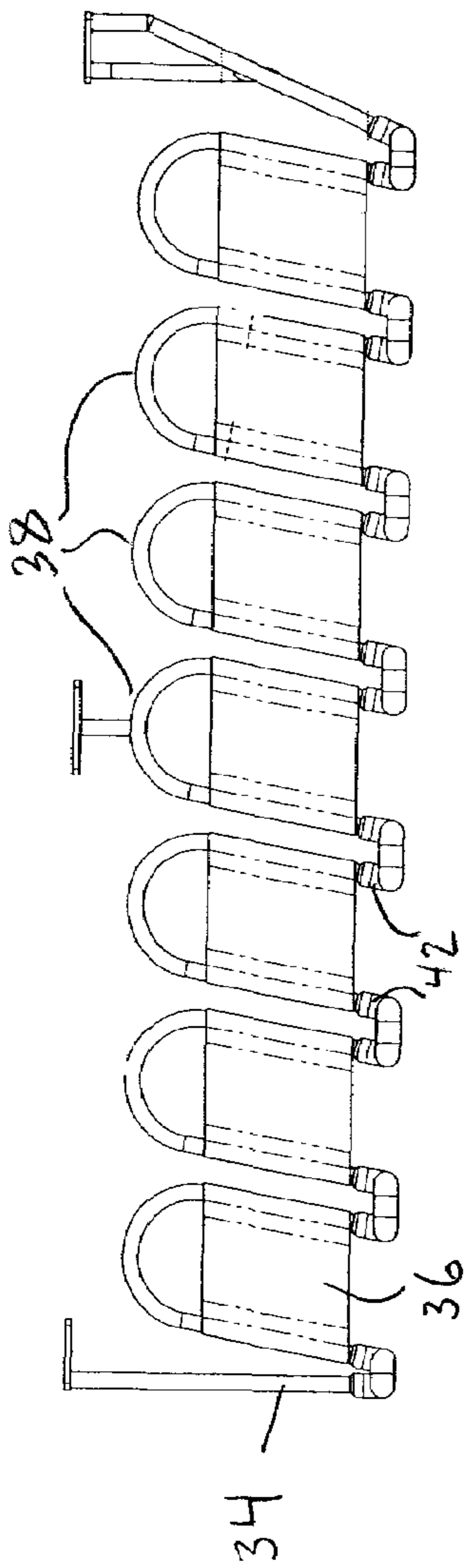

FIG. 9

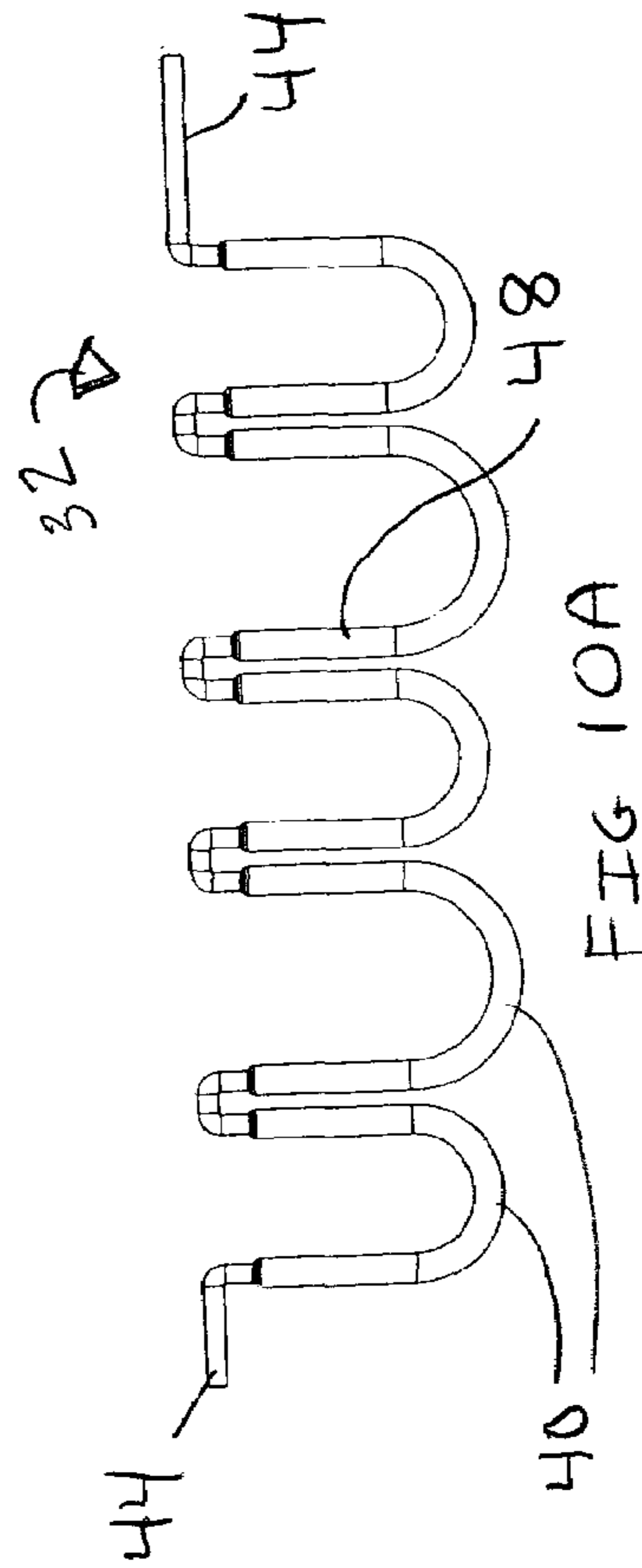

FIG. 10A

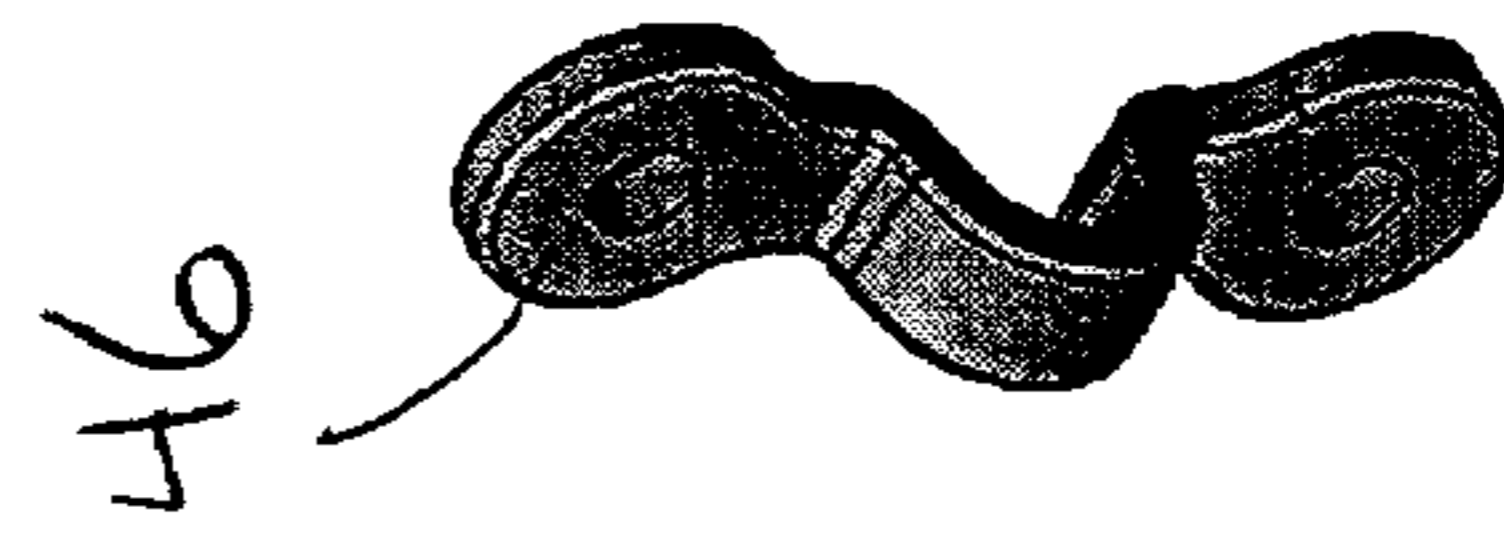

FIG. 10B

GUN SAFE DOOR STORAGE SYSTEM

Matter enclosed in heavy brackets [] appears in the original patent but forms no part of this reissue specification; matter printed in italics indicates the additions made by reissue.

RELATED APPLICATIONS

This application is a continuation-in-part of commonly-owned and U.S. patent application Ser. No. 10/971,584, filed Oct. 22, 2004 *now U.S. Pat. No. 7,877,920*, which claims priority from U.S. Provisional Patent Application No. 60/513,967 filed on Oct. 24, 2003, the disclosures of which are incorporated in their entireties by reference herein.

FIELD OF INVENTION

This invention generally relates to an apparatus for holding firearms and other items on the door of a gun safe. More specifically, the invention relates to a gun safe door storage system for rifles, guns, and firearm supplies and accessories.

BACKGROUND OF INVENTION

The use of gun safes for storing and preventing unauthorized access to firearms and firearm supplies (such as ammunition) and accessories is well known. An example of a prior art gun safe is shown in FIG. 1. The interior of such prior art gun safes generally includes several shelves 2 and a rack 4 for storing rifles in a vertical position. Because the storage components are all located in the interior portion of the gun safe, the gun safe's door 6 must be substantially opened to provide access to the firearms, supplies and accessories stored therein (not shown), and a user would have to reach into the gun safe to remove any of the items stored therein.

It is also known to attach devices to the interior surface of a safe door in order provide additional means for storing firearms, supplies and accessories. For example, U.S. Pat. No. 5,957,308 to Zierenberg discloses a system for hanging pistols on the interior surface of a safe door, including a retrofittable (or removable) panel hung over the top edge of the door made from a hook-and-loop type material (such as VELCRO) and removable fabric holsters or pouches for holding pistols or other valuables also made from a hook-and-loop type material, such that the pouches are easily movable.

Other means for storing firearms, supplies or accessories on the interior surface of a gun safe door are disclosed in the Sentry® FIRE-SAFE® Gun Safes (e.g., Model GT8423). The Sentry® safes include an optional restraint cord system consisting of a bungee cord secured to the interior surface of the door in a zig-zag pattern around pegs secured through the interior surface of the door. Alternatively, hooks may be secured to the interior surface of the door for hanging items, such as spare gun barrels, pistols, binoculars, etc. The Sentry® safes may also include a door pocket recessed into the door's interior surface.

However, none of the prior art provides a means for storing rifles on the door of a gun safe to provide easier access and to reduce the risk of damage (e.g., nicks and scratches) to the rifles. As used herein, the term "rifle" generally refers to a firearm with an elongated barrel and a stock having a butt. Thus, the term "rifle" refers not only to rifles but also includes shotguns, carbines and other similar firearms. It is a broad object of the invention to provide a gun safe door storage system that provides easy access to rifles, minimizes risk of

damage to rifles, and also provides a wide range of storage options for firearm supplies and accessories to efficiently maximize the use of space on the interior surface of a gun safe door.

SUMMARY OF INVENTION

In the present invention, the foregoing purposes, as well as others that will be apparent, are achieved generally by providing a gun safe door storage system that is permanently affixed to an interior surface of a gun safe door. The door storage system comprises a plurality of integrated pouches or pockets and a rifle rack arranged such that the pouches or pockets are accessible even when the rifle rack is holding rifles. Substantially all of the available space on the interior surface of the door is filled with pockets or pouches. The pouches or pockets are affixed to a backing material having strength and weight sufficient to prevent sagging. The backing material is permanently affixed to the interior surface of the gun safe door.

A rifle rack comprising a barrel support and a stock support is mounted permanently on the interior surface of the gun safe door over the pouches or pockets. The stock support is mounted on a lower portion of gun safe door and comprises one or more butt recesses or slings for receiving and securing the butt end of a rifle stock. The barrel support is mounted on an upper portion of the gun safe door at a distance above the stock support. The barrel support has one or more barrel holes or other means for receiving and securing a rifle barrel.

BRIEF DESCRIPTION OF DRAWINGS

FIG. 1 is a front elevational view of a prior art gun safe with the safe door in an open position.

FIG. 2 is a front elevational view of a gun safe door storage system prior to attachment to an interior panel of a gun safe door.

FIG. 3 is a rear, right and top side perspective view of the door storage system prior to attachment to an interior panel of a gun safe door.

FIG. 4 is a front elevational view of a gun safe door storage system after attachment to an interior panel of a gun safe door.

FIG. 5 is a side view of the gun safe door storage system shown in FIG. 4.

FIG. 6 is an alternate embodiment of a gun safe door storage system.

FIG. 7A is a perspective view of a pocket for use in a gun safe door storage system, in an open position.

FIG. 7B is a perspective view of a pocket for use in a gun safe door storage system, in a closed position.

FIG. 8 is a top view of a strap for use in a gun safe door storage system.

FIG. 9 is a perspective view of a stock support for use with the door storage system of FIG. 4.

FIG. 10A is a perspective view of a barrel support for use with the door storage system of FIG. 4.

FIG. 10B is a perspective view of a bracket for attaching the barrel support of FIG. 10A to the door storage system of FIG. 4.

DESCRIPTION OF PREFERRED EMBODIMENTS

A gun safe door storage system is shown in FIGS. 2-5. Referring to FIGS. 2 and 3, the interior portion of a gun safe door typically includes an interior panel 10 made from a sturdy material, such as sheet rock or sheet metal. The door

storage system comprises a backing material **12** of sufficient size to cover the entire interior panel **10** of the gun safe door, and has flaps **14** extending past the top, bottom and side edges of the interior panel **10**. The flaps **14** wrap around the edges of the interior panel **10** (as indicated by the arrows in FIG. **3**) and are affixed to the opposite side of the interior panel **10**. The backing material **12** (including the flaps **14**) is preferably affixed to the interior panel **10** by adhesive (hot-melt or pressure-sensitive), but may also be affixed by staples or other means of permanently affixing a flexible sheet on a flat surface, or any combination thereof. The backing material **12** is preferably Oxford Cloth (available from Wujiang Liufeng Silk Cloth Corporation Ltd., Jiangsu Province, China) or a heavy nylon material. A thin (preferably about 1/8 inch thick) plastic stiffener material is typically attached to one side of the Oxford Cloth by adhesive or stitching. Any other material that provides sufficient strength and durability to prevent sagging when the door storage system is in use may be used.

Referring now to FIGS. **4** and **5**, the door storage system is permanently affixed to and integrated into a gun safe door. The door storage system comprises a plurality of integrated pouches or pockets **16**, **18**, **20**, straps **21** and a rifle rack **22** arranged such that the pouches, pockets and straps are accessible even when the rifle rack is holding rifles (not shown). Substantially all of the available space on the interior surface of the door is filled with pockets, pouches and straps. The pouches, pockets and straps **16**, **18**, **20**, **21** are affixed to the backing material **12**, preferably by stitching or adhesive. It should be understood that the pockets, pouches and straps shown in FIGS. **2-5** are just one example of the types of pockets, pouches and straps that may be used. Many different size and shape pockets, pouches and straps may be selected and arranged in any configuration depending on the intended use and the size of the gun safe door. For example, an alternate arrangement on a smaller gun safe door is shown in FIG. **6**.

As shown in FIGS. **4** and **5**, a mesh pocket **16** comprises a mesh material affixed to the backing material **12** on the sides and gathered and affixed at the bottom, typically by stitching. An elastic band **24** is disposed at the top and affixed to the backing material **12** only on the sides such that the band can be pulled away from the backing material to provide access to the pocket **16**. When not in use, the elastic band **24** is flush with the surface of the backing material **12** (see FIG. **5**). The mesh material may be provided in varying sizes depending on the desired size of the pocket **16**.

Pockets **18** and **20** comprise a pre-formed pouch affixed to the backing material **12**, typically by stitching. The pouch may be provided in varying sizes and shapes depending on the desired size and use of the pouches. The pouches may be closed with a zipper closure device, having a zipper pull **26** or a hook-and-loop closure device **28**, such as VELCRO. A pouch having a VELCRO closure device **28** and a loop pull **30** to facilitate opening and closing the pouch is shown in FIGS. **7A** (open) and **7B** (closed).

Straps **21** comprise a material that may or may not be elastic. For example, a heavy nylon belt or a flat elastic strap may be used, or any combination thereof. The material is affixed to the backing material **12** in spaced-apart vertical lines **31** by adhesive or stitching. The fabric material is gathered between the vertical lines to form a plurality of loops **33** to holding various firearm accessories and supplies. (See FIG. **8**). The vertical lines **31** may be spaced at any interval depending on the desired end use.

Referring again to FIGS. **4** and **5**, a rifle rack comprises a barrel support **32** and a stock support **34**, each separately and permanently mounted to the interior panel **10** of the gun safe door through the backing material **12**. The barrel and stock

supports may be of the types disclosed in co-pending U.S. application Ser. No. 10/971,584 (the disclosure of which is incorporated by reference herein in its entirety). Alternatively, the stock support **34** and barrel support **32** may be made from a metal or metal alloy, such as stainless steel, rod bent and formed into a plurality of U-shaped holders **38**, **40** (see FIGS. **9** and **10**). The open ends of the U-shaped holders of the stock support **34** face outward from the interior panel **10** when the stock support **34** is installed onto the interior panel **10**. A mesh or nylon sling material **36** is attached between the outer prongs **42** of the U-shaped holders **38** for receiving and securing the butt end of a rifle stock. Use of this type of butt support is less expensive because it uses less material, and is easy to manufacture and install onto the interior panel **10**.

The barrel support **32** is mounted on an upper portion of the gun safe door at a distance above the stock support such that the open ends of the U-shaped holders are disposed adjacent the interior panel **10**. This permits the closed end of the U-shaped holders to receive and secure a rifle barrel. Each end of the barrel support **32** extends to form a pin **44** that is used for mounting the barrel support **32** onto the interior panel **10**. The pins fit into brackets **46** mounted on both sides of the door to permit the barrel support **32** to pivot 180 degrees. (See FIG. **10A**) Thus, when there are no rifles in the rack, the barrel support **32** can lay flat against the backing material **12**. The barrel support may also be installed without this pivoting feature.

The U-shaped holders **40** are dimensioned to allow rifle barrels to be easily inserted or removed therefrom and to securely hold rifle barrels as the safe door opens and closes. Each U-shaped holder **40** is positioned on the barrel support **32** so that it registers with a corresponding U-shaped holder **38** in the stock support **34** when the barrel support and stock support are mounted on the interior panel **12**. Each U-shaped holder **40** coacts with a corresponding U-shaped holder **38** to receive, secure and hold a rifle upright on the rifle rack. Preferably, each U-shaped holder **40** is provided with a vinyl dip cover **48** or other material suitable for securing and protecting rifle barrels.

The barrel and stock supports **32**, **34** may be affixed to the interior panel **10** by gluing, welding, riveting or with fasteners, preferably self tapping sheet metal screws that anchor into steel Z bars (not shown) that are attached to the safe door.

The barrel support **32** is positioned above the stock support **34** at a height sufficient to allow the barrel support and butt support to securely hold rifles of the size generally used by sportsmen, hunters and gun enthusiasts but still allow rifles to be easily placed into or removed from the rifle rack. In the embodiment shown in FIG. **4**, the distance between the barrel support **32** and stock support **34** is about thirty-six inches. However, it is to be understood that barrel supports and stock supports separated by a greater distance or lesser distance that allow the rifle rack to be used with longer or shorter rifles, or to hold rifle parts, such as barrels, is within the scope of the present invention. A rifle (not shown) is stored in the rifle rack by first inserting the rifle barrel into a U-shaped holder **40** of the barrel support **32** from below and then placing the rifle butt into a corresponding U-shaped holder **38** of the stock support **34**.

Although the invention has been described with reference to preferred embodiments, it will be appreciated by one of ordinary skill in the art that numerous modifications are possible in light of the above disclosure. For example, in an alternate embodiment (not shown) the butt support comprises a unitary structure having one or more butt recesses. In addition, one or more barrel holes may be provided with a locking

5

means to limit access to particular rifles. In another alternate embodiment (not shown), the barrel support may be split cross-wise into two or more pieces that are mounted on the safe door at different heights above the stock support. This would enable rifles of varying lengths, or rifle parts, such as barrels, to be stored on the rifle rack. All such variations and modifications are intended to be within the scope and spirit of the invention.

I claim:

1. A storage system for use in a gun safe having a door with an interior surface, the system comprising:

a backing material permanently affixed to the interior surface of the door;

a plurality of pockets permanently affixed to the backing material; and

a rack affixed to the interior surface of the door over the backing material and the plurality of pockets, such that space on the interior surface of the door is maximized

2. A storage system according to claim 1, wherein the rack comprises:

a barrel support affixed to the interior surface of the door over the backing material and the plurality of pockets; and

a stock support affixed to the interior surface of the door over the backing material and the plurality of pockets.

3. A storage system according to claim 2, wherein the barrel support is positioned on the interior surface of the door at a height above the stock support.

4. A storage system according to claim 3, wherein the height is sufficient to store rifles in the rack.

5. A storage system according to claim 1, wherein the plurality of pockets are selected from the group consisting of gathered and sewed pockets and pre-formed pockets.

6. A storage system according to claim 5, wherein the gathered and sewed pockets comprise a mesh material affixed to the backing material on three sides and an elastic top band.

7. A storage system according to claim 1, further comprising a plurality of straps affixed to the backing material to form horizontal loops for storage.

8. A gun safe having a door with an interior surface, comprising:

a backing material permanently affixed to the interior surface of the door;

a plurality of pockets permanently affixed to the backing material; and

a rack affixed to the interior surface of the door over the backing material and the plurality of pockets, such that space on the interior surface of the door is maximized.

9. A gun safe according to claim 8, wherein the rack comprises:

a barrel support affixed to the interior surface of the door over the backing material and the plurality of pockets; and

a stock support affixed to the interior surface of the door over the backing material and the plurality of pockets.

10. A gun safe according to claim 9, wherein the barrel support is positioned on the interior surface of the door at a height above the stock support.

11. A gun safe according to claim 10, wherein the height is sufficient to store rifles in the rack.

12. A gun safe according to claim 8, wherein the plurality of pockets are selected from the group consisting of gathered and sewed pockets and pre-formed pockets.

13. A gun safe according to claim 12, wherein the gathered and sewed pockets comprise a mesh material affixed to the backing material on three sides and an elastic top band.

6

14. A gun safe according to claim 8, further comprising a plurality of straps affixed to the backing material to form horizontal loops for storage.

15. A method for storing items in a gun safe have a door with an interior surface, the method comprising the steps of: permanently affixing a backing material to the interior surface of the door;

permanently affixing a plurality of pockets to the backing material; and

affixing a rack to the interior surface of the door over the backing material and the plurality of pockets, such that space on the interior surface of the door is maximized.

16. A method according to claim 15, wherein the backing material is permanently affixed to the interior surface of the door by applying adhesive between the interior surface of the door and the backing material.

17. A method according to claim 15, wherein the pockets are affixed to the backing material by stitching around a border of each of the pockets.

18. A method according to claim 15, further comprising the step of permanently affixing a strap in a generally horizontal disposition across the interior surface of the door to provide additional storage options.

19. *A storage system for use in a gun safe having a door with an interior panel, the system comprising: a backing material permanently affixed to the interior panel of the door; a plurality of pockets permanently affixed to the backing material; and a rack positioned on the interior panel of the door for holding at least one rifle, the backing material covering an entire inner surface of the interior panel and comprising flaps extending past and wrapped around a top edge, a bottom edge and side edges of the interior panel, the flaps being secured to the interior panel on a surface opposite the inner surface.*

20. *A storage system according to claim 19, further comprising a plurality of straps permanently affixed to the backing material such that a substantial portion of the surface area of the inner surface of the interior panel is filled with pockets and straps.*

21. *A storage system according to claim 19, wherein the rifle rack comprises a stock support positioned on a lower portion of the inner surface of the interior panel and comprising at least one butt recess disposed at an acute angle relative to the interior surface of the safe door, and a barrel support positioned on an upper portion of the interior surface of the interior panel, each of the stock support and the barrel support having an outer edge extending away from the inner surface at a right angle and tapering to an acute angle relative to the inner surface to form a cut-away portion in the outer edge of each of the barrel support and the stock support.*

22. *A storage system for use in a gun safe having a door with an interior panel, the system comprising: a backing material covering an entire inner surface of the interior panel, the backing material comprising storage elements filling a substantial portion of the surface area of the inner surface of the interior panel and flaps extending past and wrapped around a top edge, a bottom edge and side edges of the interior panel, the flaps being secured to the interior panel on a surface opposite the inner surface; and a rack positioned on the interior panel for holding at least one rifle.*

23. *A storage system according to claim 22, wherein the storage elements comprise a plurality of pockets and straps permanently affixed to the backing material.*

24. *A storage system according to claim 22, wherein the rack comprises a stock support positioned on a lower portion of the inner surface of the interior panel and a barrel support positioned on an upper portion of the inner surface.*

7

25. A storage system for use in a gun safe having a door with an interior panel, the system comprising: a backing material covering an entire inner surface of the interior panel, the backing material comprising flaps extending past and wrapped around a top edge, a bottom edge and side edges of the interior panel, the flaps being secured to the interior panel on a surface opposite the inner surface; the backing material comprising storage elements filling a substantial portion of the surface area of an inner surface of the interior panel.

26. A storage system according to claim 25, wherein the storage elements comprise a plurality of pockets and straps permanently affixed to the backing material.

27. A storage system according to claim 25, further comprising a stock support positioned on a lower portion of the inner surface of the interior panel and a barrel support positioned on an upper portion of the inner surface to secure a rifle to the inner surface of the interior panel.

28. A method for storing items in a gun safe having a door with an interior panel, the door being hingedly attached to a first side frame of the gun safe, the method comprising:

covering an inner surface of the interior panel with a backing material comprising flaps that extend past a top edge, a bottom edge and side edges of the interior panel and a plurality of pockets and straps permanently affixed to backing material, such that substantially the entire inner surface is covered with pockets and straps;

wrapping the flaps around the top edge, the bottom edge and the side edges;

securing the flaps to the interior panel on a surface opposite the inner surface.

8

29. A method according to claim 28, further comprising positioning a stock support on a lower portion of the inner surface of the interior panel and a barrel support on an upper portion of the inner surface to secure a rifle to the inner surface.

30. A gun safe comprising: a door having an interior panel; a backing material affixed to the interior panel and covering an entire inner surface of the interior panel, the backing material comprising flaps extending past and wrapped around a top edge, a bottom edge and side edges of the interior panel, the flaps being secured to the interior panel on a surface opposite the inner surface; a plurality of pockets permanently affixed to the backing material; and a rack positioned on the interior panel for holding at least one rifle.

31. A gun safe according to claim 30, further comprising a plurality of straps permanently affixed to the backing material such that a substantial portion of the surface area of the inner surface of the interior panel is filled with pockets and straps.

32. A gun safe comprising a door having an interior panel; a backing material covering an entire inner surface of the interior panel, the backing material comprising flaps extending past and wrapped around a top edge, a bottom edge and side edges of the interior panel, the flaps being secured to the interior panel on a surface opposite the inner surface; the backing material comprising storage elements filling a substantial portion the surface area of the inner surface of the interior panel.

33. A gun safe according to claim 32, wherein the storage elements comprise a plurality of pockets and straps permanently affixed to the backing material.

* * * * *