

US00RE44501E

(19) **United States**
(12) **Reissued Patent**
Janna et al.

(10) **Patent Number:** **US RE44,501 E**
(45) **Date of Reissued Patent:** **Sep. 17, 2013**

(54) **HINDFOOT NAIL**
(75) Inventors: **Sied W. Janna**, Memphis, TN (US);
William Stewart, Memphis, TN (US);
Roy W. Sanders, Tampa, FL (US)
(73) Assignee: **Smith & Nephew, Inc.**, Memphis, TN
(US)

3,918,100 A 11/1975 Shaw et al.
3,937,223 A 2/1976 Roth
3,960,151 A 6/1976 Kuhn
4,135,507 A 1/1979 Harris
4,146,936 A 4/1979 Aoyagi et al.
4,186,448 A 2/1980 Brekke

(Continued)

FOREIGN PATENT DOCUMENTS

(21) Appl. No.: **12/855,377**
(22) Filed: **Aug. 12, 2010**

CH 669898 4/1989
DE 1949923 4/1971

(Continued)

Related U.S. Patent Documents

Reissue of:

(64) Patent No.: **7,410,488**
Issued: **Aug. 12, 2008**
Appl. No.: **11/061,699**
Filed: **Feb. 18, 2005**

McKellop, et al., Development and Clinical Performance of a Reversible Titanium Alloy Femoral Intramedullary Nail, Scientific Exhibit #3512, American Academy of Orthopaedic Surgeons, 58th Annual Meeting, Mar. 7-11, 1991.

(Continued)

(51) **Int. Cl.**
A61B 17/58 (2006.01)

(52) **U.S. Cl.**
USPC **606/62**

(58) **Field of Classification Search**
USPC 606/62-68; 623/21.18
See application file for complete search history.

Primary Examiner — Kevin T Truong
Assistant Examiner — Michael Araj
(74) *Attorney, Agent, or Firm* — Fish & Richardson P.C.

(56) **References Cited**

U.S. PATENT DOCUMENTS

2,136,471 A 11/1938 Schneider
2,952,254 A 9/1960 Keating
2,987,062 A 6/1961 Ellison
3,272,204 A 9/1966 Artandi et al.
3,463,158 A 8/1969 Schmitt et al.
3,531,561 A 9/1970 Trehu
3,596,656 A 8/1971 Kaute
3,636,956 A 1/1972 Schneider
3,739,773 A 6/1973 Schmitt et al.
3,876,068 A 4/1975 Sonnino
3,892,649 A 7/1975 Phillips et al.
3,902,497 A 9/1975 Casey

(57) **ABSTRACT**

The present invention relates to a nail and fastener assembly for use in providing a stable construct for optimal fixation of the hindfoot and to methods for implanting the nail and fastener assembly. One embodiment of the nail and fastener assembly provides additional fixation, for example, in the form of one or more threaded bores, to hold the fasteners in a fixed position. Another embodiment provides angled bores to allow multi-planar and multi-axial implantation of the fasteners. In some instances, the fasteners may cross one or more articulating surfaces of the foot. For example, the fastener may traverse one or more of the calcaneo-cuboid and the talo-calcaneal articulating surfaces to aid in more secure stabilization of the hindfoot.

22 Claims, 6 Drawing Sheets

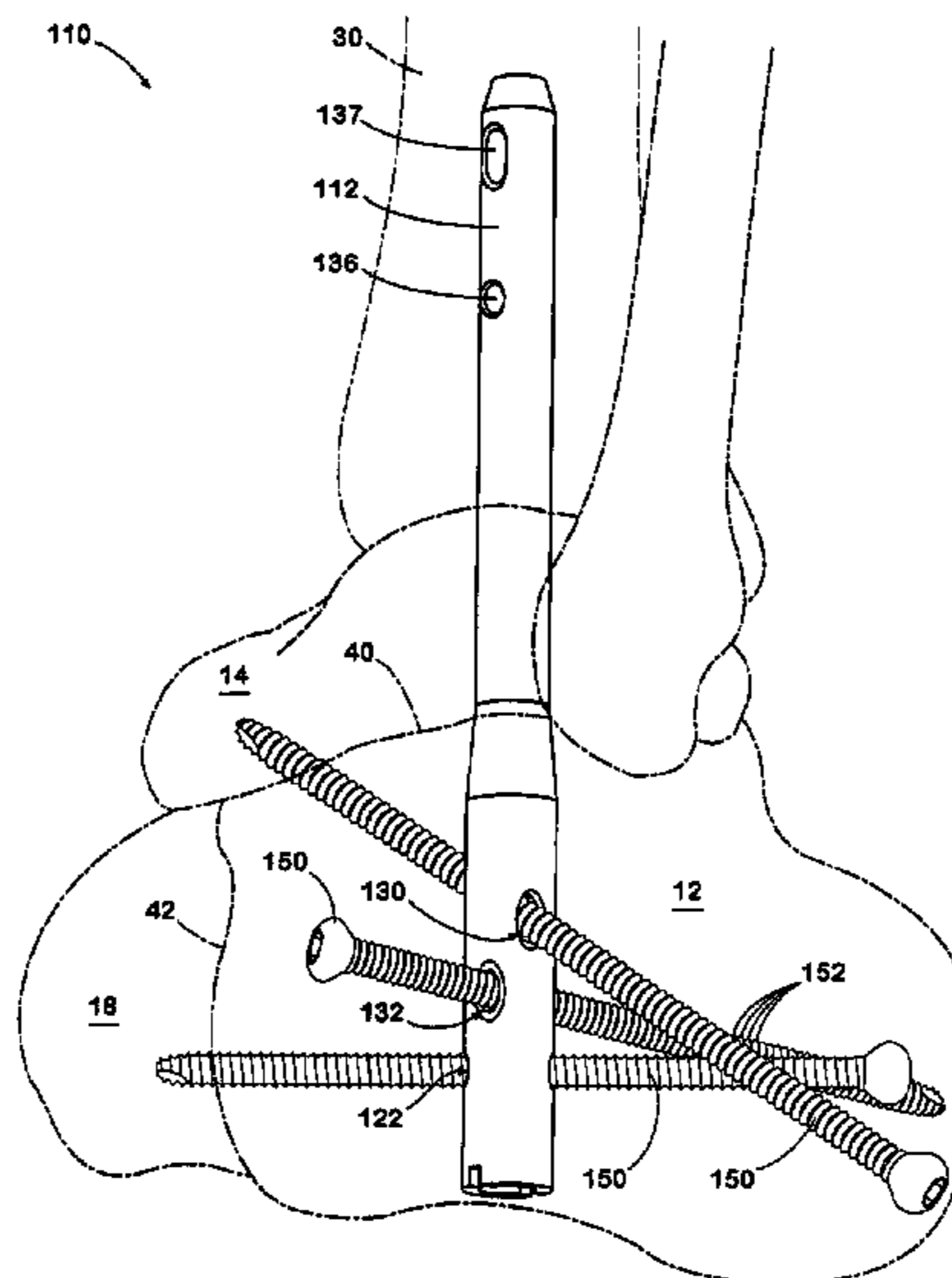

(56)

References Cited

U.S. PATENT DOCUMENTS			
4,191,185	A	3/1980	Lemieux
4,192,021	A	3/1980	Deibig et al.
4,219,015	A	8/1980	Steinemann
4,279,249	A	7/1981	Vert et al.
4,280,233	A	7/1981	Raab
4,292,694	A	10/1981	Koeneman
4,338,926	A	7/1982	Kummer et al.
4,429,690	A	2/1984	Angelino-Pievani
4,457,301	A	7/1984	Walker
4,465,065	A	8/1984	Gotfried
4,475,545	A	10/1984	Ender
4,503,847	A	3/1985	Mouradian
4,522,202	A	6/1985	Otte et al.
4,523,591	A	6/1985	Kaplan et al.
4,550,449	A	11/1985	Tunc
4,612,923	A	9/1986	Kronenthal
4,622,959	A	11/1986	Marcus
4,644,943	A	2/1987	Thompson et al.
4,655,203	A	4/1987	Tormala et al.
4,705,027	A	11/1987	Klaue
4,733,654	A	3/1988	Marino
4,751,183	A	6/1988	Sonneborn et al.
4,756,307	A	7/1988	Crowninshield
4,776,330	A	10/1988	Chapman et al.
4,781,183	A	11/1988	Casey et al.
4,790,302	A	12/1988	Colwill et al.
4,846,162	A	7/1989	Moehring
4,851,008	A	7/1989	Johnson
4,863,475	A	9/1989	Andersen et al.
4,875,474	A	10/1989	Border
4,875,475	A	10/1989	Comte et al.
4,895,572	A	1/1990	Chernoff
4,896,661	A	1/1990	Bogert et al.
4,898,186	A	2/1990	Ikada et al.
4,911,153	A	3/1990	Border
4,919,666	A	4/1990	Buchhorn et al.
4,943,292	A	7/1990	Foux
4,968,317	A	11/1990	Tormala et al.
4,973,333	A	11/1990	Treharne
4,976,258	A	12/1990	Richter et al.
4,989,186	A	1/1991	Ricker
5,009,664	A	4/1991	Sievers
5,034,013	A	7/1991	Kyle et al.
5,035,697	A	7/1991	Frigg
5,041,114	A	8/1991	Chapman et al.
5,057,110	A	10/1991	Kranz et al.
5,057,111	A	10/1991	Park
5,066,296	A	11/1991	Chapman et al.
5,084,050	A	1/1992	Draenert
5,084,051	A	1/1992	Tormala et al.
5,108,399	A	4/1992	Eitenmuller et al.
5,112,333	A	5/1992	Fixel
5,123,911	A	6/1992	Granger et al.
5,127,913	A	7/1992	Thomas, Jr.
5,190,546	A	3/1993	Jervis
5,201,735	A	4/1993	Chapman et al.
5,236,431	A	8/1993	Gogolewski et al.
5,248,313	A	9/1993	Greene et al.
5,250,049	A	10/1993	Michael
5,263,431	A	11/1993	Wood
5,269,784	A	12/1993	Mast
5,275,601	A	1/1994	Gogolewski et al.
5,292,695	A	3/1994	Galloway
5,413,577	A	5/1995	Pollock
5,441,500	A	8/1995	Seidel et al.
5,458,654	A	10/1995	Tepic
5,472,444	A	12/1995	Huebner et al.
5,484,438	A	1/1996	Pennig
5,501,695	A	3/1996	Anspach et al.
5,514,137	A	5/1996	Coutts
5,520,690	A	5/1996	Errico et al.
5,549,610	A	8/1996	Russell et al.
5,569,250	A	10/1996	Sarver et al.
5,584,836	A	12/1996	Ballintyn et al.
5,603,715	A	2/1997	Kessler
5,618,286	A		
5,653,709	A		
5,658,287	A		
5,662,472	A		
5,720,766	A		
5,725,541	A		
5,730,744	A		
5,741,266	A		
5,741,282	A		
5,743,914	A		
5,766,174	A		
5,776,194	A		
5,792,400	A		
5,810,821	A		
5,836,949	A		
5,855,579	A		
5,868,746	A		
5,871,484	A		
5,876,402	A		
5,879,389	A		
5,895,390	A		
5,927,978	A		
5,928,267	A		
5,935,127	A		
6,004,323	A		
6,015,937	A		
6,019,761	A		
6,053,918	A		
6,106,528	A		
6,120,504	A		
6,123,708	A		
6,168,595	B1		
6,197,029	B1		
6,228,086	B1		
6,248,108	B1		
6,261,291	B1		
6,270,304	B1		
6,270,499	B1		
6,296,645	B1		
6,309,392	B1		
6,319,253	B1		
6,368,319	B1		
6,383,187	B2		
6,443,954	B1		
6,488,684	B2		
6,514,253	B1		
6,524,314	B1		
6,527,775	B1		
6,572,620	B1		
6,572,655	B1		
6,579,293	B1		
6,602,255	B1		
6,605,090	B1		
6,626,906	B1		
6,673,116	B2		
6,706,046	B2		
6,709,436	B1		
6,730,093	B2		
6,755,834	B2		
6,783,529	B2		
6,786,908	B2		
6,926,720	B2		
6,951,561	B2		
7,655,009	B2		
2001/0021851	A1		
2001/0031966	A1		
2001/0037112	A1		
2002/0029041	A1		
2002/0062128	A1		
2002/0072748	A1		
2002/0133156	A1		
2002/0133158	A1		
2002/0151898	A1		
2003/0009219	A1		
2003/0018336	A1		
2003/0055428	A1		
2003/0069581	A1		
2003/0078583	A1		
2003/0097131	A1		
4/1997			Brinker
8/1997			Frigg
8/1997			Hofmann et al.
9/1997			Grutzner
2/1998			Zang et al.
3/1998			Anspach, III et al.
3/1998			Justin et al.
4/1998			Moran et al.
4/1998			Anspach, III et al.
4/1998			Skiba
6/1998			Perry
7/1998			Mikol et al.
8/1998			Talja et al.
9/1998			Vandewalle
11/1998			Campbell, Jr. et al.
1/1999			James et al.
2/1999			Sarver et al.
2/1999			Spievack et al.
3/1999			Errico et al.
3/1999			Koshino
4/1999			Moran et al.
7/1999			Muller
7/1999			Bonutti et al.
8/1999			Border
12/1999			Park et al.
1/2000			Bränemark
2/2000			Gustilo
4/2000			Spievack
8/2000			Durham et al.
9/2000			Brumback et al.
9/2000			Kilpela et al.
1/2001			Durham et al.
3/2001			Fujimori et al.
5/2001			Wahl et al.
6/2001			Törmälä et al.
7/2001			Talaber et al.
8/2001			Freedland
8/2001			Leu et al.
10/2001			Hover et al.
10/2001			Alexander et al.
11/2001			Ackeret et al.
4/2002			Schaefer
5/2002			Törmälä et al.
9/2002			Bramlet et al.
12/2002			Sterghos et al.
2/2003			Yao
2/2003			Dean et al.
3/2003			Warburton
6/2003			Schon et al.
6/2003			Johnson
6/2003			Chandran
8/2003			Campbell et al.
8/2003			Trieu et al.
9/2003			Young
1/2004			Reiley
3/2004			Orbay et al.
3/2004			Sturgeon et al.
5/2004			Saint Martin
6/2004			Amis
8/2004			Hover et al.
9/2004			Hover et al.
8/2005			Castaneda
10/2005			Warren et al.
2/2010			Grusin
9/2001			Eberlein et al.
10/2001			Tormala et al.
11/2001			Brace et al.
3/2002			Hover et al.
5/2002			Amis
6/2002			Robioneck
9/2002			Cole
9/2002			Saint Martin
10/2002			Sohnngen et al.
1/2003			Seyr et al.
1/2003			Vandewalle
3/2003			Swanson
4/2003			Stinson et al.
4/2003			Biedermann et al.
5/2003			Schon et al.

2003/0195515 A1 10/2003 Sohngen
 2003/0199876 A1 10/2003 Brace et al.
 2004/0030342 A1 2/2004 Trieu et al.
 2004/0092942 A1 5/2004 Reiley
 2004/0097935 A1 5/2004 Richelsoph et al.
 2004/0127899 A1 7/2004 Konieczynski et al.
 2004/0127900 A1 7/2004 Konieczynski et al.
 2004/0127904 A1 7/2004 Konieczynski et al.
 2004/0158252 A1 8/2004 Prager et al.
 2004/0260290 A1 12/2004 Zander et al.
 2005/0101958 A1 5/2005 Adam
 2005/0187550 A1 8/2005 Grusin
 2005/0261555 A1 11/2005 Guzman et al.
 2006/0100623 A1 5/2006 Pennig
 2006/0173457 A1 8/2006 Tornier
 2007/0123878 A1 5/2007 Shaver et al.
 2008/0015587 A1 1/2008 Munoz
 2008/0287949 A1 11/2008 Keith et al.

FOREIGN PATENT DOCUMENTS

DE 196 29 011 A1 1/1998
 DE 19629011 1/1998
 DE 19945611 9/2001
 DE 203 00 987 U1 4/2003
 DE 20300987 5/2003
 DE 203 09 399 U1 8/2003
 DE 20309399 10/2003
 DE 19945611 11/2005
 EP 0 299 004 B1 1/1989
 EP 0 355 411 A1 2/1990
 EP 0355411 2/1990
 EP 0 491 983 A1 7/1992
 EP 0 583 442 B1 2/1994
 EP 0299004 3/1994
 EP 0491983 3/1996
 EP 0 710 091 B2 5/1996
 EP 0710091 5/1996
 EP 0583442 10/1996
 EP 1 415 604 A1 5/2004
 EP 1415604 5/2004
 FR 2710835 4/1995
 SU 1692566 11/1991
 SU 1692566 A1 11/1991
 WO WO 96/35387 11/1996
 WO WO 98/41161 9/1998
 WO WO 98/46169 10/1998
 WO WO98/41161 12/1998
 WO WO 00/61018 10/2000
 WO WO00/61018 6/2002
 WO WO 03/017822 3/2003

OTHER PUBLICATIONS

Raiha, 'Biodegradable Implants as Intramedullary Nails. A Survey of Recent Studies and an Introduction to Their Use,' *Clinical Materials*, 10:35-39 (1992).
 Hofmann, 'Editorial Biodegradable Implants in Orthopaedic Surgery,' *Clinical Materials*, 10:1 Table of Contents (1992).
 "Alta Modular Trauma System . . . The leading edge in fracture management technology . . . The alta® tibial/humeral rod module for reamed and non-reamed procedures," 10 pages, Jan. 1992.
 Kato, et al., 'The Weakest Link in the Bone Plate Fracture System: Changes with Time, Clinical and Laboratory Performance of Bone Plates,' ASTM STP 1217, ed. By Harvey and Games, pp. 85-94, (1994).
 Nazre, et al., 'Theoretical Strength Comparison of Bioabsorbable (PLLA) Plates and Conventional Stainless Steel and Titanium Plates Used in Internal Fracture Fixation,' *Clinical and Laboratory Performance of Bone Plates*, ASTM STP 1217, J.P. Harvey, Jr., and R. F. Games, Eds., American Society for Testing and Materials, Philadelphia, 1994, pp. 53-64.
 Yeadon, et al., 'Influence of Axially Flexible Plates on Bone Healing: A Biomedical Study in Canine Femora,' CMBES 20 CCGB Vancouver 1994, pp. 34-35.

Rommens, et al., "Retrograde locked nailing of humeral shaft fractures: A review of 39 patients," *J. Bone Joint Surg. Br.*, 77(4):667, (1995) <http://www.ncbi.nlm.nih.gov/entrez/query.fcgi?cmd=Retrieve&db=PubMed&dopt=Abstra> . . .
 Biomet, Inc. Brochure 'Uniflex® Surgical Technique,' pp. 1-12, 1995.
 Biomet, Inc. Medical Products Brochure, Uniflex® Nailing System, pp. 1-14 (1995).
 Biomet, Inc. Medical Products Brochure, Trauma Systems Uniflex™ Tibial Nail System, 4 pages (1995).
 Biomet, Inc. Brochure 'Uniflex® Surgical Technique,' pp. 1-16, 1995.
 Biomet Inc. Vector Intertrochanteric Nail, Version Two, 19 pages, 1995.
 Biomet Inc., Biomet Retrograde Femoral Nail, 6 pages, 1995.
 Biomet Inc., Biomet Retrograde Femoral Nail Surgical Technique, 12 pages, 1995.
 Biomet Inc., AIM™ Titanium Femoral Nail, 11 pages, 1995.
 Biomet, Inc., Vector Intertrochanteric Nail, Version One, 18 pages, 1995.
 Biomet Medical Products Inc. 'Interlocking Nail,' 14 pages, 1995.
 Ferguson, et al., 'Finite element stress analysis of a hybrid fracture fixation plate,' *Med. Eng. Phys.*, 10(5):241-250, 1996.
 Foux, et al., 'Improved Fracture Healing with Less Rigid Plates A Biomedical Study in Dogs,' *Clinical Orthopaedics and Related Research*, 339:232-245, 1997.
 Simon, et al., 'Bioresorbable Fracture Fixation in Orthopedics: a Comprehensive Review. Part II. Clinical Studies,' *The American Journal of Orthopedics*, pp. 754-762, (Nov. 1997).
 Smith & Nephew Brochure entitled "Intramedullary Supracondylar Nail Surgical Technique," by David Seligson, M.D., et al., pp. 1-29 (Mar. 1998).
<http://www.biometmerck.com/english/products/tratima/ankle/htm>, on page, Jan. 6, 2005.,
 Orthofix Retrograde Nailing System, 'The long and the short of it,' Orthofix Always Innovating Brochure, 10 pages, 2002.
 Orthofix Operative Technique Brochure entitled 'The Ankle Arthrodesis Nail,' by Profs. Dr. D. Pennig, 16 pages, 2002.
 Two sheets of schematic drawings of nail marked as 'Drawing Printed 81006321B,' and one sheet of 'Period Sales Analysis by Planner' showing first sale date of Sep. 2003.
 DePuy website paper entitled the VersaNail System: A Versatile Ankle Fusion Option, pp. 1-3 (copyright 2002-2004).
 Dr. Rodriguez's www.chicagofootandanklesurgery.com (Ante Fusion) web page, pp. 1-3 (Mar. 11, 2005 <http://www.cfaas.com/anklefusion.htm>).
 Encore: True/Fix® Proximal Humeral Nail web page, pp. 1-2, Jan. 19, 2005 http://www.encoremed.com/orthopedics/products/trauma/proximal_humeral_nail.html.
 EBI Products website paper entitled "Excellence By Innovation" one page (undated), Sep. 2010.
 Brochure of Intramedullary Nail. One Nail . . . Diaphyseal Fractures. URTN System Introduction, The Titanium Unreamed Tibial Nail System: the next generation in Unreamed Tibial Nails from Synthes and the AO/ASIF, one page, Sep. 28, 2010.
 Parts List, undated, Sep. 28, 2010.
 EBI Products website paper entitled "Excellence By Innovation" one page, May 30, 2012.
 Brochure of Intramedullary Nail. One Nail . . . Diaphyseal Fractures, May 30, 2012.
 Parts List, undated, May 30, 2012.
 URTN System Introduction, The Titanium Unreamed Tibial Nail System: the next generation in Unreamed Tibial Nails from Synthes and the AO/ASIF, one page, May 30, 2012.
 Ordway, Craig B., AIM Titanium Femoral Nail System Surgical Technique, Ace Medical Company, pp. 1-8, 1994.
 Brochure entitled "Stryker T2™ Proximal Humeral Nailing System Operative Technique" Stryker Trauma®, 20 pages, 2003.
 Office Action for U.S. Appl. No. 13/614,006, mailed Mar. 19, 2013.
 Office Action for U.S. Appl. No. 13/483,742, mailed Mar. 28, 2013.

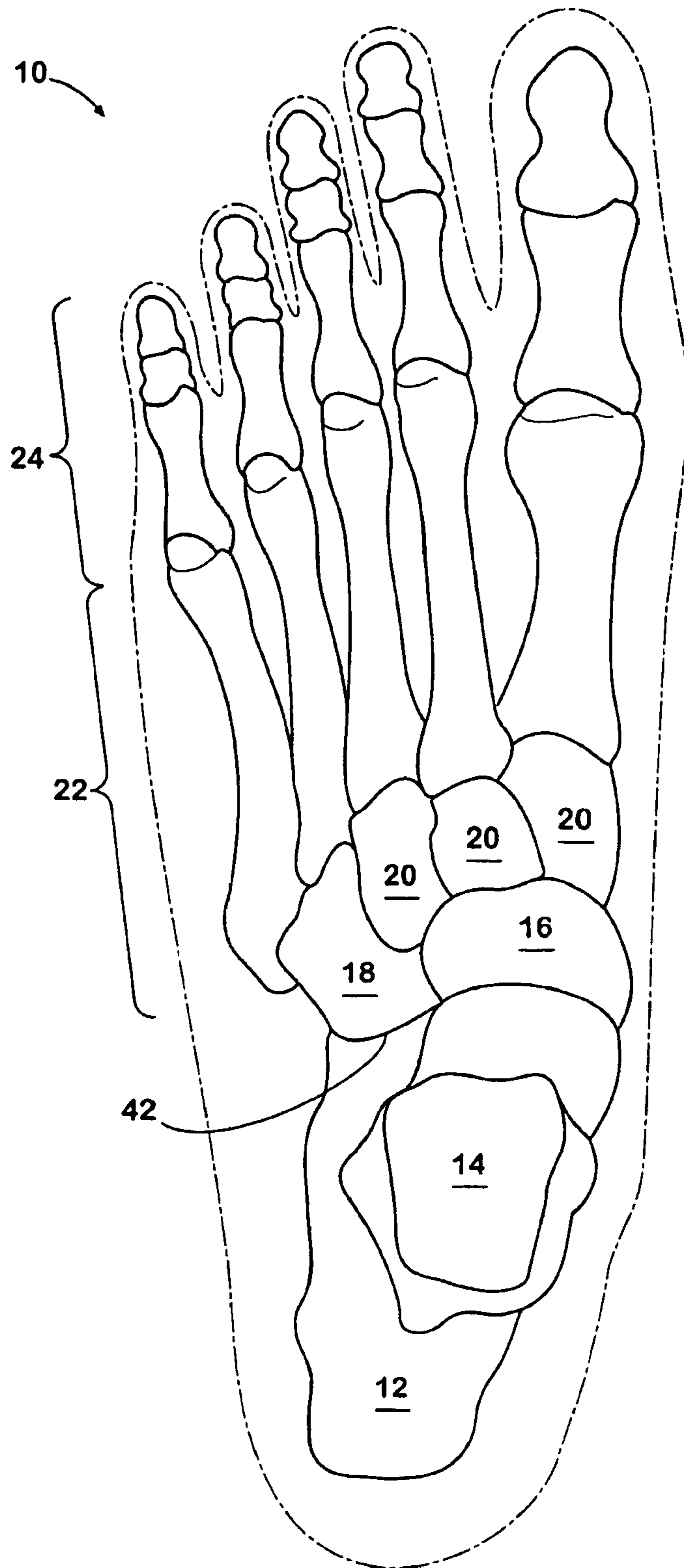

FIG 1

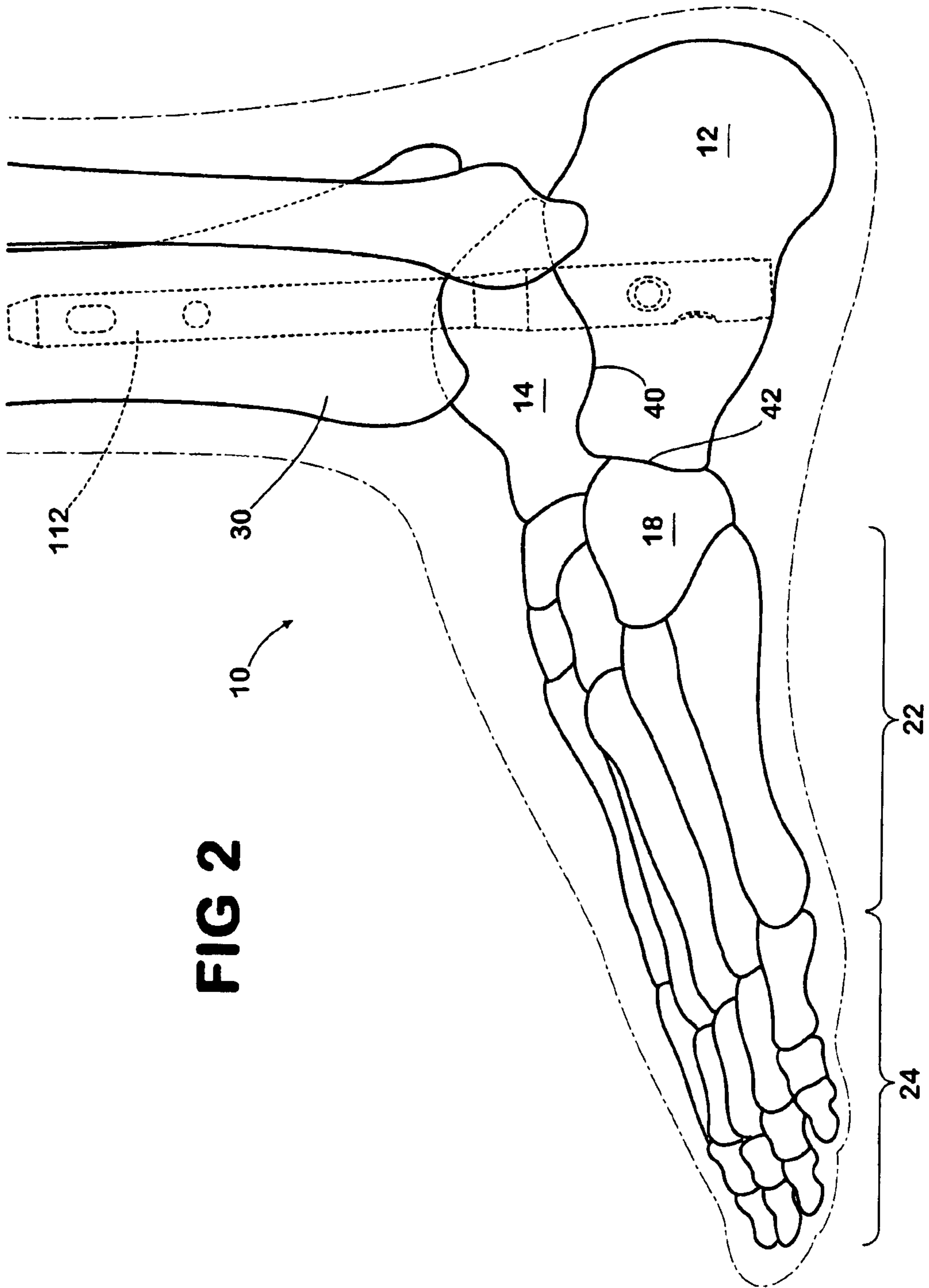

FIG 2

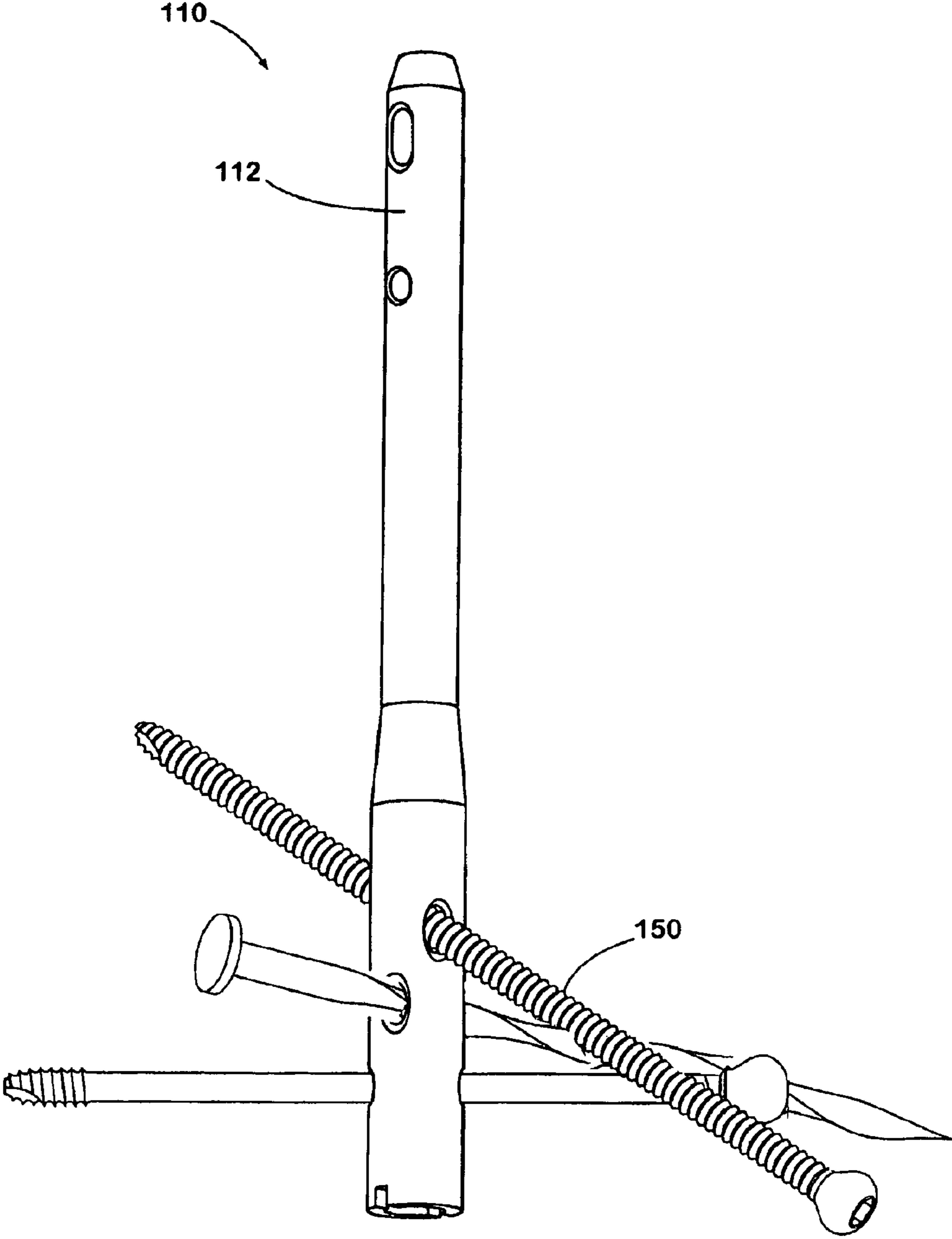

FIG 3

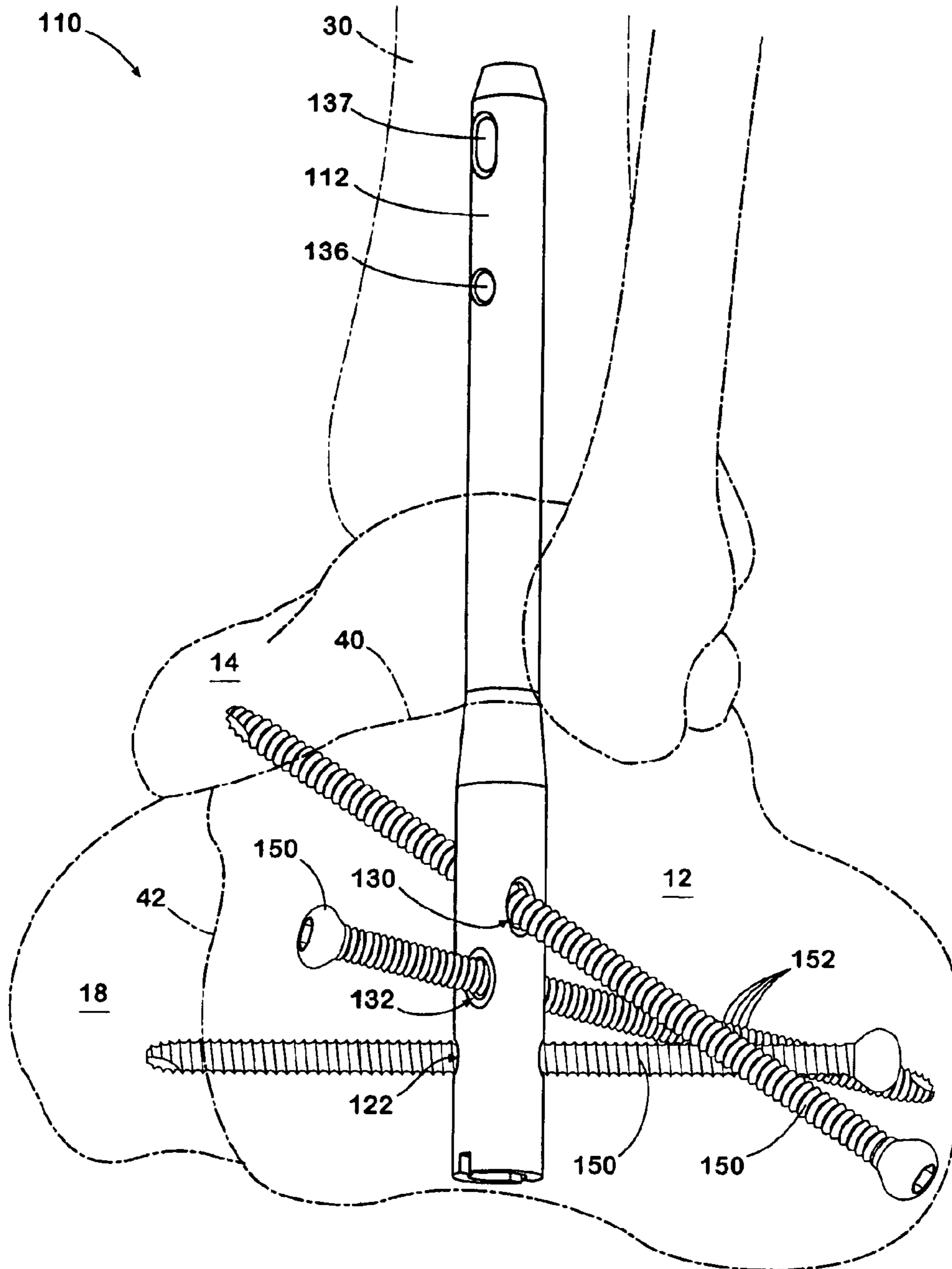

FIG 3A

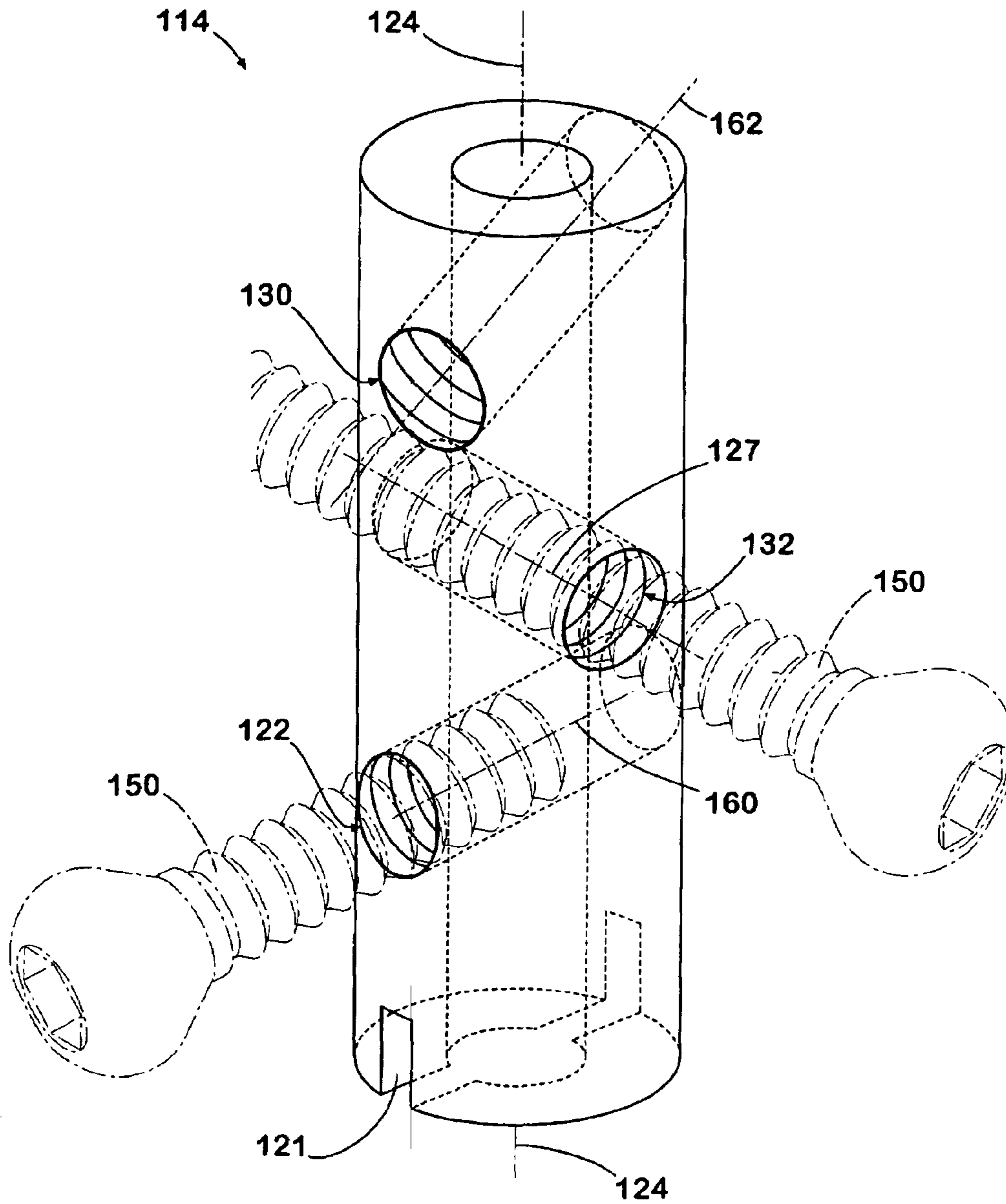

FIG 6

1

HINDFOOT NAIL

Matter enclosed in heavy brackets [] appears in the original patent but forms no part of this reissue specification; matter printed in italics indicates the additions made by reissue.

FIELD OF THE INVENTION

The invention relates to nail and fastener assemblies that provide stable fixation of the hindfoot.

BACKGROUND

Serious ankle problems can be caused by a number of conditions, such as arthritis (e.g., osteoarthritis, rheumatoid arthritis), diabetes, trauma, accidents, or severe deformation. One solution is to replace the ankle joint with an implant or ankle prosthesis. However, prostheses often fail due to subsidence, wear, and loosening within a few years following implantation. There are also anatomical considerations that make such implants non-feasible in some cases. Poor results with prostheses have led many surgeons to abandon implant arthroplasty in more serious cases and return to ankle arthrodesis—fusing the joint to ultimately result in bone fusion. Often, by the time fusion is selected as the best option, there is minimal motion at the joint prior to surgery.

Ankle fusion typically involves using screws and pins to hold the bone together. In a typical fusion surgery, the ankle joint is fused, allowing the tibia (shinbone) to grow together or fuse with the talus bone, the bone of the ankle that articulates with the tibia and fibula, and the calcaneus, the bone that forms the ankle joint. A long ankle arthrodesis “nail” may be inserted through the heel and fixed into place with screws or pins. Often, one or more screws or pins are inserted into the calcaneus, the bone at the lower back part of the foot forming the heel, which provides more stability.

Many of the currently available ankle fusion systems are less than optimal. One reason is because the screws or pins used to fuse the foot bones are secured only into the foot bones themselves; they are not secured to the ankle arthrodesis nail through which they are received. In some instances, an unsecured screw or pin can dislodge itself from the patient’s bone and migrate out over years of use. Thus, there is a need in the art to provide a better solution to reduce the risk of migration.

Another reason that many of the currently available fusion systems are less than optimal is because they do not have angled fastener-receiving holes that allow for multi-planar fixation. Alternatively, dangled holes are present, they are not provided at optimal angle ranges for securing and immobilizing the ankle.

In some commercially available systems, the center of the fastener-receiving hole opening(s) in the ankle arthrodesis nail is perpendicular to the longitudinal axis of the nail, such that when the fastener is inserted, it is also perpendicular to the nail. This does not allow the surgeon to achieve purchase into preferred bones of the foot, but instead, limits the surgeon to securing the fastener into the calcaneus (the heel bone). Such systems also fail to provide the option of inserting fasteners in multiple axes to provide a more stable fixation system.

Moreover, fusion systems typically include one or more fasteners that engage only one foot bone in use. The fasteners do not cross articulating surfaces. It would be advantageous to provide a system that allows one or more fasteners to cross

2

one or more articulating surfaces of the bones in the foot in order to provide more stability.

Another disadvantage of some fusion systems is that they do not provide nails with reinforced distal portions. If the nail is the same diameter throughout its length, but there are fastener holes in the distal portion, the implant may be weaker at that portion due to increased stresses from the patient’s weight. Thus, there is a need for a fusion system that provides greater rigidity and stability in use.

Accordingly, it would be advantageous to provide a nail and fastener assembly that addresses many of the problems that have not been solved by currently-available systems.

SUMMARY

The present invention comprehends various embodiments of nail and fastener assemblies, which may be employed, among other things, for use in providing a stable construct for optimal fixation of the hindfoot. It also comprehends various methods for implanting the nail and fastener assemblies.

Because bone quality is typically poor in patients who are candidates for this procedure, it is beneficial for a system to include a nail that provides additional fixation to hold the fasteners, which may be screws, pins, partially threaded screws, fasteners having a surface with threads or blades of various pitches, shapes, and rotations about the fastener, helical blades, bolts, or any other structure capable of holding and/or engaging bone, in a fixed position. It is also beneficial for a system to provide the option of stabilizing various articulating surfaces of the foot.

Accordingly, certain embodiments of the present invention provide fusion systems with fixation features between the nail and fastener that secure the fastener into the nail. Other embodiments provide a fusion system with one or more openings of the nail that receive fasteners at various angles, allowing one or more fastener to cross one or more articulating surfaces of the foot to provide for multi-planar and multi-axial implantation of the fasteners. Certain structures provide a fusion system with a fastener that crosses one or more of the talo-calcaneal and the calcaneo-cuboid articulating surfaces. Other embodiments combine these features or aspects of them.

One structure according to certain embodiments of the invention includes a hindfoot nail with a threaded fastener-receiving hole. Other structures include angled fastener-receiving bores, and further structures include assemblies adapted to fuse articulating surfaces of a patient’s foot. Methods of the invention provide methods for at least partially fusing certain bones of the patient’s hindfoot.

Certain devices of the present invention accomplish these results in a number of ways, some of which are discussed in detail below, with reference to the drawings.

BRIEF DESCRIPTION OF THE DRAWINGS

FIG. 1 shows a dorsal view of the anatomy of the foot.

FIG. 2 shows a side view of a foot having an implanted nail according to one embodiment of the invention.

FIG. 3 shows a perspective view of one embodiment of a nail and fastener assembly.

FIG. 3A shows a perspective hind view of a foot having an implanted nail and fastener assembly according to another embodiment of the invention.

FIG. 4 shows a side view of a nail according to one embodiment of the invention.

FIG. 4A shows a cross-sectional view of the nail of FIG. 4.

FIG. 5 shows another cross-sectional view of the nail of FIG. 4.

FIG. 6 shows a cross-sectional schematic view of the threaded angled bores of the nail of FIG. 4 showing fasteners (in phantom) inserted.

DETAILED DESCRIPTION OF THE DRAWINGS

Anatomy of the Foot and Ankle:

There are twenty-six bones in the human foot **10**, shown in FIGS. 1 and 2. There are seven tarsal bones: the bone that forms the heel is the calcaneus **12**; the talus **14** connects to and supports the tibia **30** (shown in FIG. 2) at the ankle. The five other tarsal bones are the navicular **16**, the cuboid **18**, and three cuneiforms **20**, which form the middle of the foot. Next, five metatarsals **22** form the lower portion of the instep of the foot. The metatarsals **22** radiate out to the phalanges **24**, which are the toe bones.

Of the tarsal bones, the talus **14** and the calcaneus **12** are the largest and are adjacent to each other. Also adjacent to the calcaneus **12** is the cuboid **18**. The calcaneus **12** and the talus **14** define an articulating surface **40** between the two bones (the talo-calcaneal articulating surface), and the calcaneus **12** and the cuboid **18** also define an articulating surface **42** (the calcaneo-cuboid articulating surface). Some or all of these, or combinations of them, are the foot bones and articulating surfaces that can be of particular interest to certain embodiments of the present invention.

Fusion System:

FIGS. 3 and 3A each show a fusion assembly **110** according to embodiments of the invention. Assembly **110** features a nail **112** and one or more fasteners **150**. In FIG. 3, some fasteners **150** are shown as partially threaded and partially smooth or fully threaded. In FIG. 3A, all fasteners **150** are shown having threads **152**. In short, a surgeon may choose to use a combination of any type of fasteners.

As shown in FIG. 2, nail **112** is adapted to be implanted into a patient's tibial canal. The fasteners **150** are adapted to be inserted through and received by the nail **112** and secure to particular bones of the foot. Different nails **112** are typically provided for the left and right sides of a patient's body to account for differing angles.

As shown in FIG. 4, nail **112** has a distal portion **114** and a proximal portion **116**. As best seen in FIGS. 2 and 3A, part of the proximal portion engages the tibia and part of the distal portion engages the calcaneus. Nail **112**, as is the case with other components of embodiments disclosed herein, can be formed of Titanium, Titanium alloys, Surgical Steel alloys, or other desired material. Distal portion **114** is shown having a greater outer diameter relative to the proximal portion **116** and may be considered, if desired, also to include a frustoconical transition segment between the portion with the greater outer diameter and the smaller outer diameter. However, distal portion **114** need not necessarily have a greater outer diameter than other portions of the nail **112**.

Nail **112** can be also cannulated, if desired. One form of such cannulation is shown in FIGS. 4-5 and can be accomplished by gundrilling or other appropriate techniques. Such cannulation enhances the ability of the nail **112** to be inserted using a closed surgical procedure, such as over a guide wire or rod. Cannulation in the distal portion **114** or portions of it, can be of greater diameter than cannulation in the proximal portion **116** or portions of it, as desired.

At the distal portion **114** is a driving end **118** that has an instrument-receiving portion **120**. Instrument-receiving portion **120** may include any type of connecting portion, such as a threaded bore **119** (shown in FIG. 5) that is adapted to

receive and fasten to implantation instruments. Instrument-receiving portion **120** may also have an optional keyway **121** (shown in FIG. 6) that can provide additional stabilization with respect to implantation instruments. Other options for connecting the instrument-receiving portion **120** to implantation instruments may be a ball and detent mechanism, a dovetail and slot configuration, a lock and key configuration, or any other stable locking mechanism.

Because distal portion **114** of nail **112** (which again may, if desired, contain some or all of the frustoconical transition shown in FIGS. 4-5) may include one or more angled fastener holes **122**, **130**, distal portion **114** may be provided with an outer diameter that is larger than the diameter at proximal portion **116**. In the particular embodiment shown in FIGS. 4-5, the greater outer diameter can in some ways be considered to provide favorable properties such as any or all of increased resistance to bending, rigidity, strength, stability, durability and enhanced reception and/or retention of fasteners.

One aspect of embodiments of the present invention is that one or more fasteners are received by and secured to a nail, as well as being secured to the patient's bone. See, e.g., FIG. 3A. One structure used to accomplish the securing of the fastener to the nail can be a threaded bore and threaded fastener combination. In this example, the nail can have a threaded bore **128** and the fastener can have corresponding threads **152** at or near the portion received by the nail.

In the specific embodiment shown in FIG. 3A, the fastener is a threaded screw **150**. Threads **152** may be provided in any number of shapes (e.g., trapezoidal teeth, triangular teeth, square teeth), pitches, and rotations (e.g., tightly wound around fastener or "loosely" wound such that there is a greater distance between each thread). The screw threads and the threads of the nail need not have the same shape, pitch, or rotation, although they typically will.

In an alternate embodiment (not shown), the fastener is a partially threaded screw. Again, the threads may be provided in any number of shapes, pitches, and rotations. In this example, the threads are preferably located at or near the portion where the threads are secured into nail to prevent their migration.

In a further embodiment, the fastener has a series of cutting edges that engage a patient's bone. Cutting edges may be cutting blades, helical blades, spikes, or any other structure capable of holding and/or engaging bone. Cutting edges may cover all or just a portion of fastener. Alternatively, fastener may feature a bolt, a moly bolt, a tension spring, or any other structure capable of holding and/or engaging bone.

In use, the threaded bore **128** is adapted to receive and secure a corresponding structure on fastener with respect to nail **112**, as well as allow fastener to engage with bone. One or more openings in the nail **112** may be provided as threaded bores. It is also possible to provide a nail **112** having a combination of threaded and non-threaded bores (the non-threaded bore structure is described below). It is also possible to provide openings in the nail that are partially threaded and partially non-threaded.

One optional feature that may be provided with assembly **110** is an insert or bushing (not shown) to prevent rotation of the fastener. See pending S&N application Ser. No. 10/999, 572, filed Nov. 30, 2004 and titled "Humeral Nail," the entire contents of which are hereby incorporated by this reference. This feature may provide a function similar to fastener anchors that can be used to hang a picture on a wall, i.e., the insert interferes with the rotation of the fastener in the nail and can prevent it from wobbling or threading out, without interfering with the ability of the fastener to insert into the nail at

5

a range of angles. The insert may be used in connection with a threaded or non-threaded bore. It may be secured with respect to nail by the threads, by a rib and locking ring configuration, by injecting a biologic or bone cement through the cannulation as each fastener is inserted, by an interference fit, or any other securing means.

A further aspect of some embodiments of the present invention is that fusion of the hindfoot can be established by connecting and stabilizing certain articulating surfaces of the foot. In one specific embodiment, the talus **14** and the calcaneus **12** are connected to one another by a fastener that crosses the talo-calcaneal articulating surface when implanted. In another specific embodiment, the cuboid **18** and the calcaneus **12** are connected to one another by a fastener that crosses the calcaneo-cuboid articulating surface when implanted. This may be done by specifically targeting these bones using an assembly **110** with angled holes or bores according to one embodiment of the present invention, as shown in FIG. **3A**. This particular embodiment provides for multi-planar (and if desired, multi-axial) fixation. The nail may also be adapted to be secured to the tibia **30** for additional stability.

One particularly beneficial aspect of providing angled fastener holes **122**, **130** is that they are provided such that any fastener received therein can target specific bones. In one structure according to certain embodiments of the invention, the fasteners are pin-like or substantially smooth. In another structure, the fasteners may have a portion that is threaded (or that contains cutting blades, helically shaped structures having any angle relative to the fastener axis, or other fastening structure to engage bone) that are adapted to secure to a patient's bone, and a portion that is at least partially smooth. These fasteners may be referred to as compression screws, an example of which is shown in FIG. **3**.

Compression screws have a portion adapted to attach to a patient's bone, as well as an at least partially smooth portion that articulates with the nail for sliding compression. The at least partially smooth surface is allowed to "slide" within the nail, such that when the patient applies pressure to the implant (for example, if the implant is a weight-bearing implant in the foot, the patient applies pressure when stepping down), the fastener compresses the bones together. The bone fragments are allowed to slide and bear on each other for better healing and fusion of the site.

In certain embodiments, the portion that cooperates with a patient's bone is adapted to cooperate with the calcaneus, and in other embodiments, the portion that cooperates with a patient's bone is adapted to cross one or more articulating surfaces of the foot.

Alternatively, angled fastener holes may have internal threads **128**. In use, internal threads **128** of nail **112** cooperate with fastener threads **152** of fasteners **150** to secure the fasteners into the nail **112**, as well as into the patient's bone. For ease of reference, fasteners will be referred to as fasteners **150** (which are shown as threaded screws) throughout the remainder of this application, although it is understood that fasteners may take any of the above-described forms, such as compression screws, pins, partially threaded screws, and so forth. See e.g. FIG. **3**.

In embodiments in which the fastener is adapted to cross articulating surfaces, fastener holes **122**, **130** are provided at optimal angles that allow the surgeon to achieve fastener attachment into particular bones of the foot, such as the calcaneus **12**, the talus **14**, and the cuboid **18**. Angled fastener holes **122**, **130** are oriented so that fasteners **150** can be inserted into the nail **112** and cross one or more of the articulating surfaces **40** and **42** of the foot bones.

6

For example, consider nail **112** having a central longitudinal axis **124** as shown in FIGS. **4-5**. At least one angled fastener hole **122** is positioned at an angle θ that is between about 45° and about 135° off of the central longitudinal axis **124**. (In other words, when a fastener is inserted through the hole **122**, the fastener itself creates an axis **160** that forms an angle of between about 45° and about 135° with the central longitudinal axis **124**, as shown in FIG. **4A**.) In a particular embodiment, at least one angled fastener hole **122** is positioned at an angle between about 65° and about 115° off of the central longitudinal axis **124**. In an even more preferred embodiment, the angled fastener hole **122** is positioned at an angle between about 80° and about 90° off of the central longitudinal axis **124**, and most preferably, at about 85° off of the central longitudinal axis **124**.

Central longitudinal axis **124** also intersects a plurality of planes. One cross-section defined by central longitudinal axis **124** is central plane **125**, which is the plane in the page of the paper. This cross-sectional view is shown in FIG. **4A**. In addition to its angled orientation with respect to central longitudinal axis **124**, angled fastener hole **122** may also be disposed at an angle that is rotated off of the plane **125** of the paper. (In other words, when a fastener is inserted through hole **122**, the fastener forms a second plane that is not aligned with plane **125** and would either extend from or retreat into plane **125** of the paper.) In one embodiment, fastener **150** may either be rotated about $0-45^\circ$ into the plane **125** of the page or rotated about $0-45^\circ$ out of the plane **125** of the page. In one embodiment, angled fastener hole **122** is rotated about $2-30^\circ$ off of plane **125**. In a further embodiment, it is rotated about $5-15^\circ$ off of plane **125**, and is most preferably, about 10° off of plane **125**. (This angle may be in either the medial or the lateral direction.)

In certain embodiments, angled fastener hole **122** is adapted to receive a fastener that targets the cuboid **18** in use, or that at least partially traverses the calcaneo-cuboid articulating surface **42**, as shown in FIG. **3**.

A second angled fastener hole **130** may also be positioned on the distal portion **114** of nail **112**. This angled fastener hole **130** may be positioned at an angle α that is between about 25° and about 135° off of the central longitudinal axis **124**, such that a fastener inserted therein forms axis **162**. In a particular embodiment, second angled fastener hole **130** is positioned at an angle between about 45° and about 115° off of the central longitudinal axis **124**. In an even more preferred embodiment, second angled fastener hole **130** is positioned at an angle between about 50° and about 75° off of the central longitudinal axis **124**, and most preferably, second angled fastener hole **130** is positioned at about 55° off of the central longitudinal axis **124**.

In addition to its angled orientation with respect to central longitudinal axis **124**, second angled fastener hole **130** may also be rotated at an angle off of plane **125**. For example, angled fastener hole **130** may be rotated about $0-45^\circ$ off of plane **125**, as shown in FIG. **6**. In one embodiment, angled fastener hole **130** is rotated about $2-30^\circ$ off of plane **125**. In a further embodiment, it is rotated about $5-15^\circ$ off of plane **125**, and is most preferably, about 10° off of plane **125**. (Again, this angle may also be in either the medial or the lateral direction. It is preferred, although not required, that angled fastener hole **122** be about 10° in the opposite direction of angled fastener hole **130**.)

In certain embodiments, second angled fastener hole **130** is adapted to receive a fastener that targets the talus **14** in use, or that at least partially traverses the talo-calcaneal articulating surface **40**, as shown in FIG. **3**.

There may be provided a third fastener hole **132**, which also has internal threads **128**, but that may or may not be provided at an angle. Consider nail **112** with a horizontal axis **127** that is perpendicular to the central longitudinal axis **124** and that defines a horizontal plane perpendicular to plane **125** (i.e., extending out from the page). FIG. **5** shows the nail of FIG. **4** cut through a plane that extends perpendicular to plane **125** and then rotated 90° to illustrate the threaded bore of fastener hole **132**.

In one embodiment, fastener hole **132** is disposed through distal portion **114** of nail **112** in the horizontal plane, give or take a few degrees. When fastener **150** is inserted through fastener hole **132**, the fastener creates an axis that forms an angle of between about 80°-100°, and preferably about 90° with the central longitudinal axis **124**, as shown in FIG. **3**. In certain embodiments, the third fastener hole **132** is a transverse fastener that targets the calcaneus **12**.

In use, a surgeon may choose to use one or more of threaded holes **122**, **130**, **132**, or any combination thereof. For example, a surgeon may only need to use hole **122**. In other cases, for example, if more stability is needed, the surgeon will also use **130** and/or hole **132**. Alternatively, a surgeon may only use hole **132**, but again, may use additional holes for additional stability.

Fasteners **150** may be provided in any number of lengths, although it is preferable that at least one fastener be provided in a length that allows it cross one of more of articulating surfaces **40** and **42**. Exemplary fastener lengths may be between 50 to 110 mm.

There may also be one or more static locking holes **136** or a dynamic compression slots **137** at the proximal portion **116** of nail **112**. These openings **136**, **137** are provided for rotational stability of assembly **110** and are typically not threaded or angled, although they can be angled and/or threaded as desired. Although the present inventors believe that it would not be good surgical practice to fix the fasteners to the holes in the proximal portion of nail **112** by threads because the nail **112** should not be overconstrained, it is understood that there could be instances when such fixation would be desired, and threaded upper holes are considered within the scope of this invention.

The surgeon may choose between static or dynamic locking by placing a fastener, pin, or small nail through either a static hole **136** or dynamic slot **137** and into the tibia **30**. It is preferred that one of each opening **136**, **137** be provided in order to give the surgeon the most flexibility, although this is not required.

Method:

A surgeon first chooses the properly-sized nail **112**. (Nails are typically provided in 10-50 cm lengths.) The choice is based on the length of the ankle from the bottom of the calcaneus to a suitable fixation point on the tibia. In essence, the goal is to fuse the nail **112** with the calcaneus **12** and the tibia **30** to immobilize the ankle joint. Typically, the surgeon will remove cartilage from the ankle to encourage the bones to fuse.

Although the surgery may be performed as a closed procedure (i.e., minimally invasive) and it is often preferable for it to be that way due to ease of healing, some surgeons may also wish to remove cartilage from between the bones prior to the procedure, which is often performed using open surgical techniques. In short, embodiments of the invention lend themselves to use during either type of procedure.

In one embodiment of the procedure, the surgeon makes an incision into the non-weight bearing part of the sole of the foot (i.e., the fatty tissue part of the heel) in line with the tibial planar axis. The surgeon may insert a guide wire into the tibial

canal to assist reaming and the placement of nail **112**. Once the canal has been reamed to an appropriate diameter and depth, the nail **112** is driven into the center (marrow) portion of the tibia **30**, typically using one or more of the instrument-receiving portion **120** or the keyway **121** for securing the implant instrumentation. Preferably, the surgeon uses a C-arm or other image intensifier to insert the nail **112** over a guide wire or rod in a closed surgical procedure as well as to insert the related fasteners.

Instrumentation may also be used to hold and guide drill bits to prepare other bones for receiving fasteners. Similar instrumentation may be used to hold and place a fastener. The fastener can be rotated into place, hammered, or otherwise inserted as desired. In some instances, guide wires may be used to place the fastener as well.

If the surgeon plans to aid the fusion process by inserting a fastener that will cross the calcaneo-cuboid articulating surface **42**, the surgeon will insert the fastener through the posterior aspect of the calcaneus, through the opening in the nail, and into the cuboid to target that junction. In the embodiment shown, the surgeon would place fastener **150** into the most inferior angled fastener hole **122**. The threads of fastener **150** cooperate with internal threads **128**, as well as achieve purchase into the calcaneus **12** and cuboid **18**. Alternatively, a compression screw, a pin, an at least partially threaded screw, or other embodiments may be used. In any event, this fastener will typically have a relatively "shallow" angle, being inserted at the calcaneus and at least partially crossing the calcaneo-cuboid articulating surface **42**.

Once the first fastener is inserted, the surgeon may gently tap the driving end **118** of the nail **112** to achieve compression of the ankle. If the surgeon plans to place a transverse fastener (in this case, a fastener that will cooperate with the calcaneus **12**), the fastener may be inserted through third fastener hole **132** in either the medial to lateral or lateral to medial direction. Even though this fastener is not necessarily strictly horizontal, it tends to be the most horizontally-located of the fasteners.

Next, if the surgeon plans to aid the fusion process by inserting a fastener that will cross the talo-calcaneal articulating surface **40**, the surgeon will insert a fastener into the posterior of the calcaneus, through an opening of the nail, and into the talus to target that junction. In the embodiment shown, the surgeon would place fastener **150** into the superior angled fastener hole **130**. The threads of fastener **150** will cooperate with internal threads **128**, as well as achieve purchase into the calcaneus **12** and talus **14**. Alternatively, a compression screw, a pin, an at least partially threaded screw, or other embodiments may be used. In any event, this fastener tends to be the most steeply angled of the three (assuming that all three fasteners are used). Assuming the patient's foot is standing on a horizontal surface, this fastener will have a relatively steep "upward" angle to at least partially cross the talo-calcaneal articulating surface **40**.

This procedure has been described as if the surgeon is using three fasteners, although it should be understood that a surgeon may choose to use fewer or more fasteners and that nails according to structures of this invention may also have fewer or more fastener-receiving bores.

After the nail and junction fasteners have been properly placed in the patient's foot, the surgeon will secure the nail **112** with a fastener at the proximal portion **116** of the nail **112**. The surgeon may choose between static or dynamic locking by placing the fastener through either a static hole **136** or a dynamic slot **137** in nail **112**.

Changes and modifications, additions and deletions may be made to the structures and methods recited above and

shown in the drawings without departing from the scope or spirit of the invention and the following claims.

What is claimed is:

1. A method for at least partially fusing a patient's calcaneo-cuboid articulating surface and talo-calcaneal articulating surface in a hindfoot fusion process, the method comprising:

(a) providing a nail having a proximal portion and a distal portion, the distal portion having a first angled fastener-receiving hole and a second angled fastener-receiving hole;

(b) providing a first fastener adapted to be received in the first angled fastener-receiving hole and a second fastener adapted to be received in the second angled fastener-receiving hole;

(c) implanting the nail into a patient's tibial canal;

(d) inserting the first fastener through the first angled fastener-receiving hole in the nail, such that the first fastener at least partially crosses the patient's calcaneo-cuboid articulating surface; and

(e) inserting the second fastener through the second angled fastener-receiving hole in the nail, such that the second fastener at least partially crosses the talo-calcaneal articulating surface.

2. The method of claim 1, wherein at least one of the first fastener-receiving hole and the second fastener-receiving hole is at least partially threaded.

3. A method of ankle arthrodesis on a patient, the patient having a tibia, a cuboid, a talus, and a calcaneus, the tibia having a tibial canal, the method comprising the steps of:

a. selecting a properly sized nail;

b. reaming the tibial canal;

c. inserting the nail into the tibial canal;

d. inserting a first fastener into the calcaneus, through the nail, and into the cuboid; and

e. inserting a second fastener into the calcaneus, through the nail, and into the talus, wherein a tip portion of the second fastener achieves purchase within the talus.

4. The method of claim 3, further comprising the step of removing cartilage from one or more bones.

5. The method of claim 3, further comprising the step of incising a non-weight bearing part of a sole of the patient's foot.

6. The method of claim 3, further comprising the step of inserting a guide wire into the tibial canal.

7. The method of claim 3, further comprising the step of inserting a transverse fastener into the calcaneus and the nail.

8. A method for fusing bones in a hindfoot fusion process, comprising:

providing a nail having a proximal portion and a distal portion and a central longitudinal axis extending therebetween, the distal portion defining at least two fastener-receiving holes, each of the holes defining a through axis offset and non-perpendicular to the nail axis, the through axes being non-parallel;

providing at least two fasteners;

implanting the nail into a patient's tibial canal; and inserting one of the fastener through one of the holes in the nail and inserting the other fastener through the other of the holes in the nail, wherein inserting one of the fasteners comprises inserting the one of the fasteners into the talus.

9. The method of claim 8 wherein inserting the other fastener comprises inserting the other fastener into the cuboid.

10. A method for fusing bones in a hindfoot fusion process, comprising:

providing a nail having a proximal portion and a distal portion and a central longitudinal axis extending therebetween, the distal portion defining at least two fastener-receiving holes, each of the holes defining a through axis offset and non-perpendicular to the nail axis, the through axes being non-parallel and constrained to non-parallel planes;

providing at least two fasteners;

implanting the nail into a patient's tibial canal; and

inserting one of the fasteners through one of the holes in the nail and inserting the other fastener through the other of the holes in the nail.

11. A method of ankle arthrodesis on a patient, the patient having a tibia, a cuboid, a talus, and a calcaneus, the tibia having a tibial canal, the method comprising:

reaming the tibial canal;

inserting a nail into the tibial canal;

inserting a first fastener into the calcaneus, through the nail, and directed toward the cuboid; and

inserting a second fastener into the calcaneus, through the nail, and into the talus, wherein the first and second fasteners are non-parallel and a tip portion of the second fastener terminates within the talus.

12. The method of claim 11 further comprising providing the first fastener with sufficient length to engage the cuboid.

13. The method of claim 12 wherein inserting the second fastener comprises inserting the second fastener into the cuboid.

14. The method of claim 11 further comprising providing the nail with two holes, each for receiving one of the fasteners, the holes having non-parallel through axes.

15. The method of claim 14 wherein providing the nail comprises the through axes being constrained to non-parallel planes.

16. The method of claim 14 wherein providing the nail comprises the distal portion defining a third hole between the two fastener-receiving holes relative to a central longitudinal axis of the nail.

17. The method of claim 16 further comprising providing a third fastener and inserting the third fastener through the third hole in the nail.

18. A method for fusing bones in a hindfoot fusion process, comprising:

providing a nail having a proximal portion and a distal portion and a central longitudinal axis extending therebetween, the distal portion defining three fastener-receiving holes, at least two of the holes defining through axes offset and non-perpendicular to the nail axis, the third hole being positioned between the at least two of the holes relative to the longitudinal axis;

providing three fasteners;

implanting the nail into a patient's tibial canal; and inserting the fasteners each through one of the holes in the nail, wherein one of the fasteners is inserted into the talus.

19. The method of claim 18 wherein another of the fasteners is inserted into the cuboid.

20. A method of ankle arthrodesis on a patient, the patient having a tibia, a cuboid, a talus, and a calcaneus, the tibia having a tibial canal, the method comprising:

reaming the tibial canal;

inserting a nail into the tibial canal;

inserting a first fastener into the calcaneus, through the nail, and directed toward the cuboid;

inserting a second fastener into the calcaneus, through the nail, and into the talus, wherein a tip portion of the second fastener terminates within the talus; and

inserting a third fastener between the first and second fastener relative to a longitudinal axis of the nail.

21. The method of claim 20 further comprising providing the nail with three holes, each hole for receiving one of the fasteners, the holes for receiving the first and second fasteners having non-parallel through axes constrained to non-parallel planes.

22. The method of claim 21 wherein providing the nail comprises the third hole being about perpendicular to the nail axis.

10

* * * * *

UNITED STATES PATENT AND TRADEMARK OFFICE
CERTIFICATE OF CORRECTION

PATENT NO. : RE44,501 E
APPLICATION NO. : 12/855377
DATED : September 17, 2013
INVENTOR(S) : Janna et al.

Page 1 of 1

It is certified that error appears in the above-identified patent and that said Letters Patent is hereby corrected as shown below:

In the Specification

Please insert Line 8 (approx.) in Column 1 as follows:

--Notice: More than one reissue application has been filed for the reissue of U.S. Patent No. 7,410,488. The reissue applications are U.S. Reissue Patent Application Serial No. 13/614,006, filed on September 13, 2012, now U.S. Reissue Patent No. RE46,008 E, issued May 24, 2016, which is a continuation reissue application of U.S. Reissue Patent Application Serial No. 13/483,742, filed on May 30, 2012, now U.S. Reissue Patent No. RE46,078 E, issued July 26, 2016, which is a divisional reissue application of U.S. Reissue Patent Application Serial No. 12/855,377 (the present application), filed on August 12, 2010, now U.S. Reissue Patent No. RE44,501 E, issued September 17, 2013.--

Signed and Sealed this
Fifth Day of June, 2018

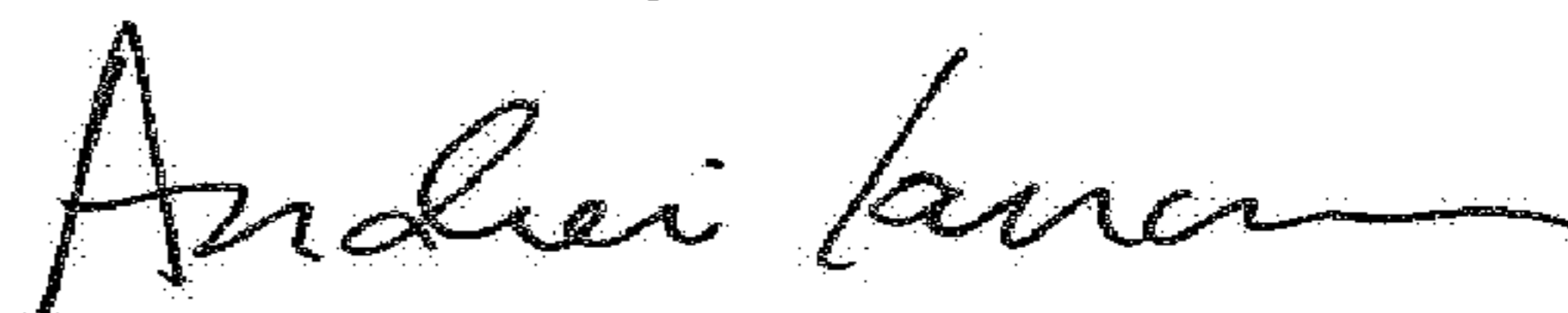

Andrei Iancu
Director of the United States Patent and Trademark Office