

US00RE44423E

(19) **United States**  
(12) **Reissued Patent**  
**Kawashima**

(10) **Patent Number:** **US RE44,423 E**  
(45) **Date of Reissued Patent:** **Aug. 13, 2013**

(54) **METHOD OF MANUFACTURING A QUARTZ CRYSTAL UNIT**

(75) Inventor: **Hirofumi Kawashima**, Tokyo (JP)

(73) Assignee: **Piedek Technical Laboratory** (JP)

(21) Appl. No.: **11/805,861**

(22) Filed: **May 24, 2007**

**Related U.S. Patent Documents**

Reissue of:

(64) Patent No.: **6,898,832**  
Issued: **May 31, 2005**  
Appl. No.: **10/278,203**  
Filed: **Oct. 22, 2002**

(30) **Foreign Application Priority Data**

Oct. 31, 2001 (JP) ..... 2001-334978  
Mar. 6, 2002 (JP) ..... 2002-060827

(51) **Int. Cl.**  
**H04L 17/00** (2006.01)  
**H01L 41/04** (2006.01)  
**H01L 41/08** (2006.01)

(52) **U.S. Cl.**  
USPC ..... **29/25.35**; 29/593; 29/594; 29/831;  
29/896.22; 29/830; 310/370

(58) **Field of Classification Search**  
USPC ..... 29/25.35, 594, 593, 896.22, 830,  
29/831; 324/727; 310/319, 361, 348, 370,  
310/313 R; 216/79, 80, 59  
See application file for complete search history.

(56) **References Cited**

**U.S. PATENT DOCUMENTS**

3,683,213 A \* 8/1972 Staudte ..... 310/370 X

4,099,078 A \* 7/1978 Shibata et al. .... 310/370 X  
4,284,946 A \* 8/1981 Sharrow ..... 324/727  
4,384,232 A \* 5/1983 Debely ..... 310/370  
4,437,773 A \* 3/1984 Dinger et al. .... 310/361 X  
5,334,900 A \* 8/1994 Kawashima ..... 310/370  
5,607,236 A \* 3/1997 Takagi et al. .... 310/370 X  
5,929,723 A \* 7/1999 Kimura et al. .... 310/313 R

**FOREIGN PATENT DOCUMENTS**

JP 56065517 A \* 5/1893  
JP 53032690 A \* 3/1978 ..... 310/370 X  
JP 55125460 A \* 9/1980 ..... 324/727  
JP 56065517 6/1981  
JP 00044092 7/2000  
JP 00223992 8/2000  
JP 2000223992 A \* 8/2000  
WO WO 0044092 \* 7/2000

\* cited by examiner

*Primary Examiner* — A. Dexter Tugbang

(74) *Attorney, Agent, or Firm* — Adams & Wilks

(57) **ABSTRACT**

In a method for manufacturing a quartz crystal unit, a quartz crystal tuning fork resonator is formed by etching a quartz crystal wafer to form a quartz crystal tuning fork base, quartz crystal tuning fork tines connected to the quartz crystal tuning fork base, and a groove having stepped portions in at least one of opposite main surfaces of each of the quartz crystal tuning fork tines. A first electrode is disposed on at least one of the stepped portions of each of the grooves and a second electrode is disposed on each of side surfaces of each of the quartz crystal tuning fork tines. A frequency of oscillation of the quartz crystal tuning fork resonator is adjusted at least twice and in different steps. The quartz crystal tuning fork resonator is then mounted in a case and an open end of the case is covered with a lid.

**49 Claims, 26 Drawing Sheets**

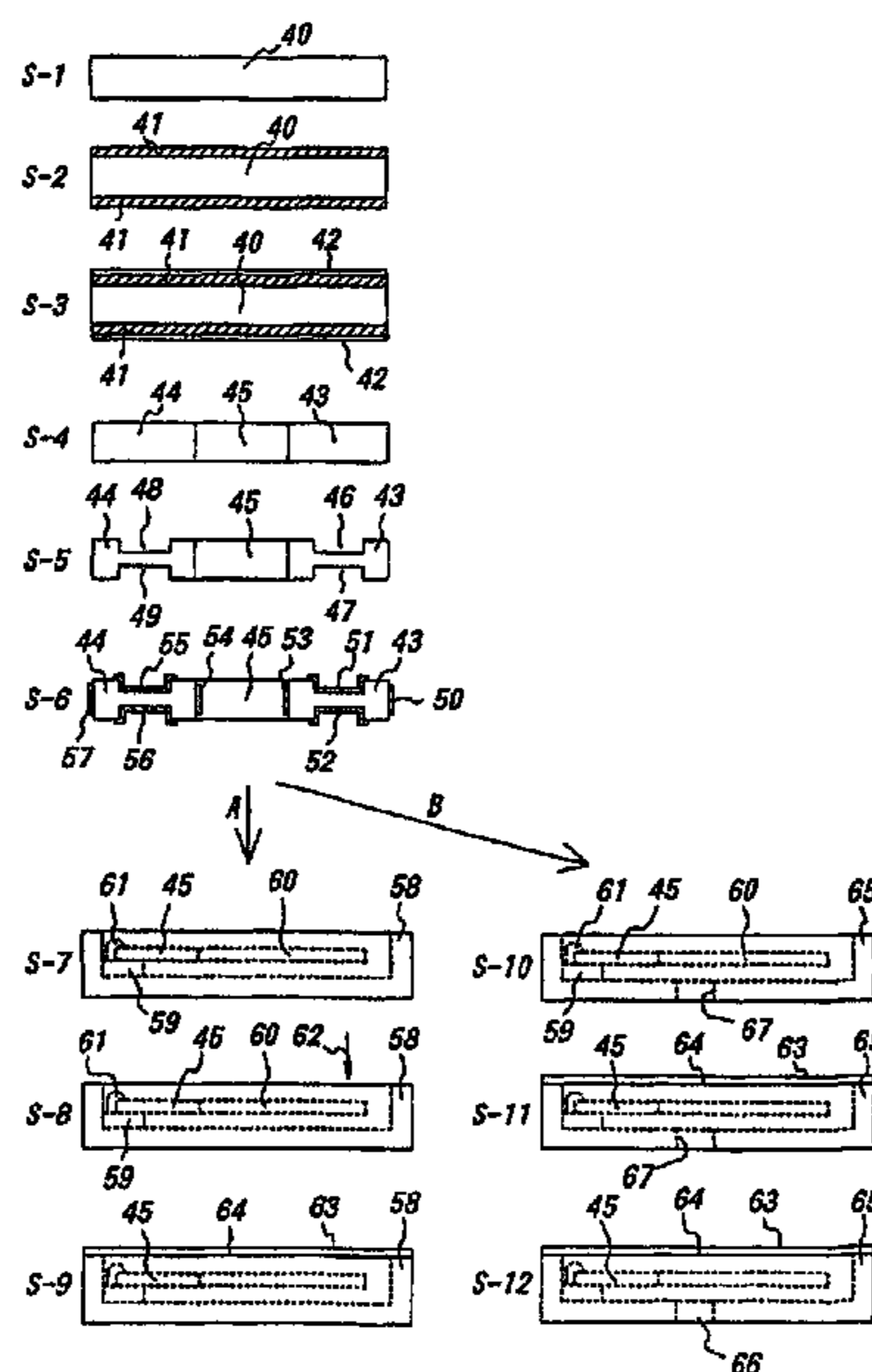

FIG. 1a

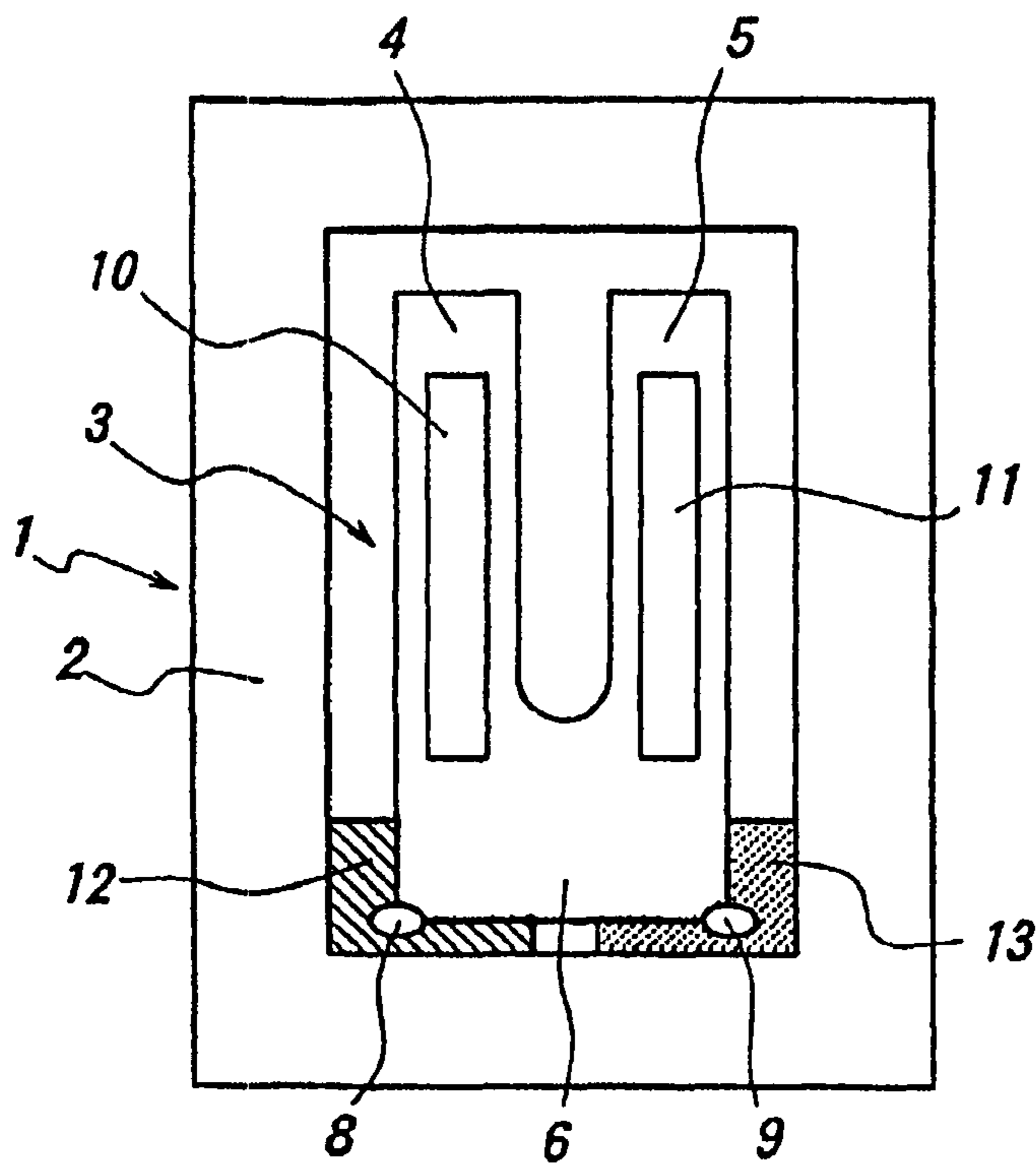

FIG. 1b

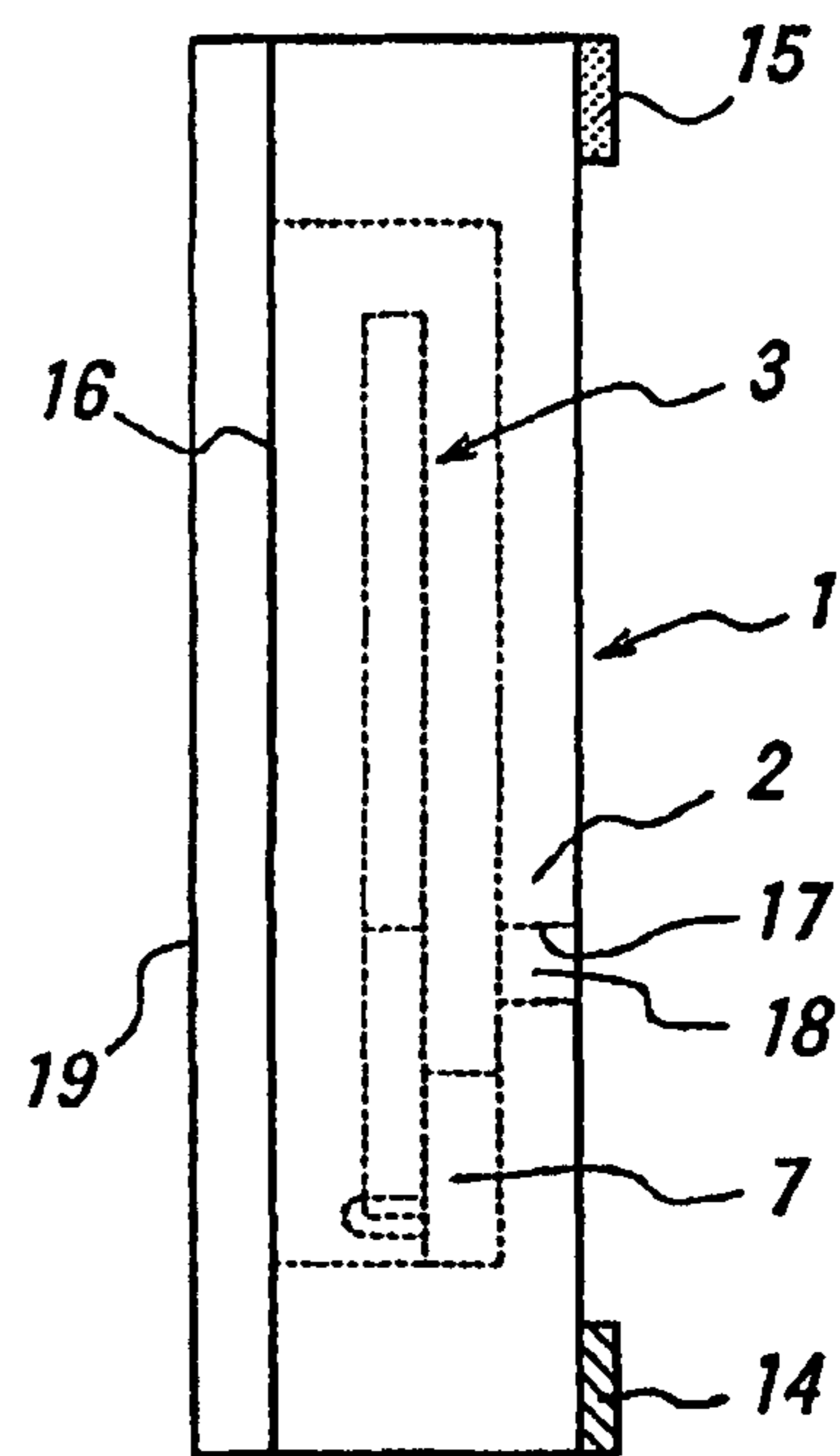

FIG. 2

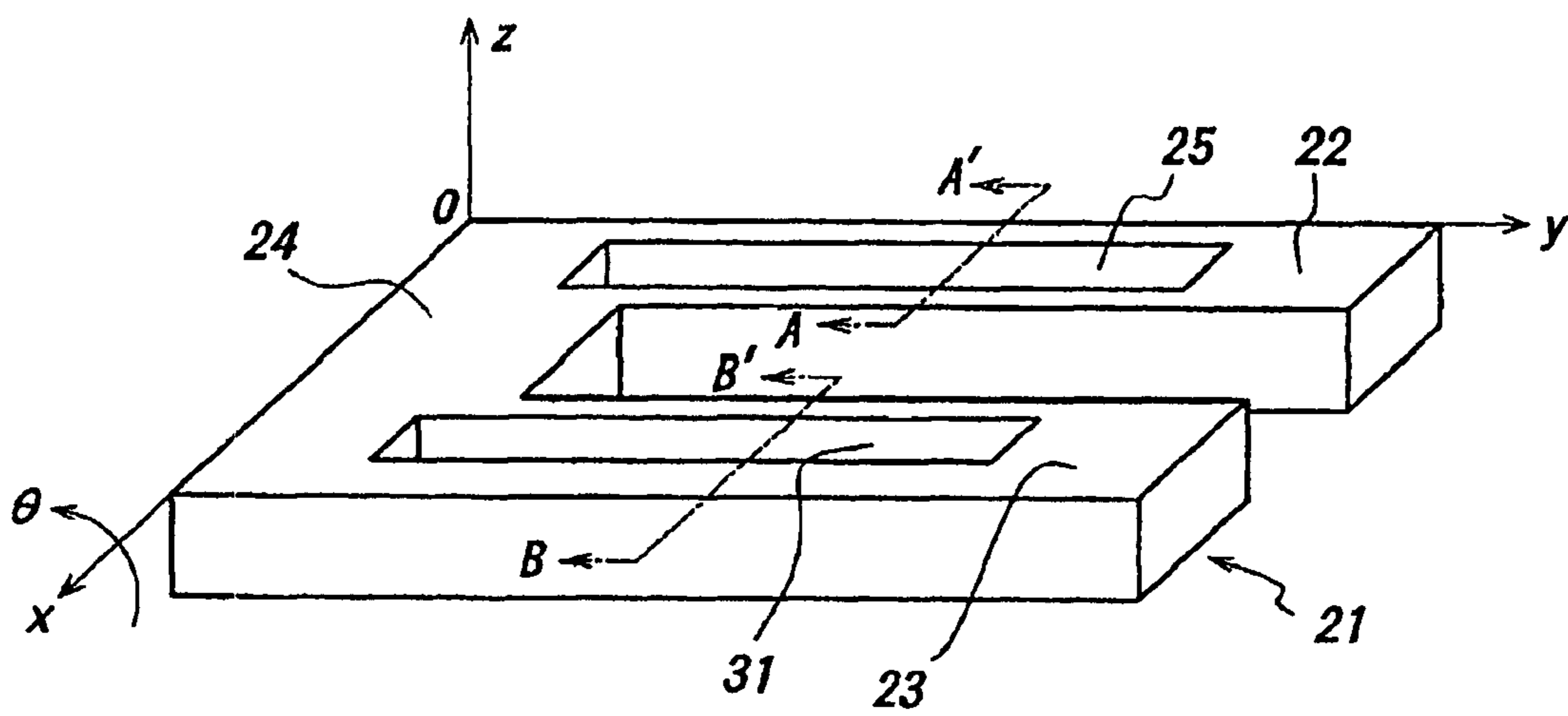

FIG. 3

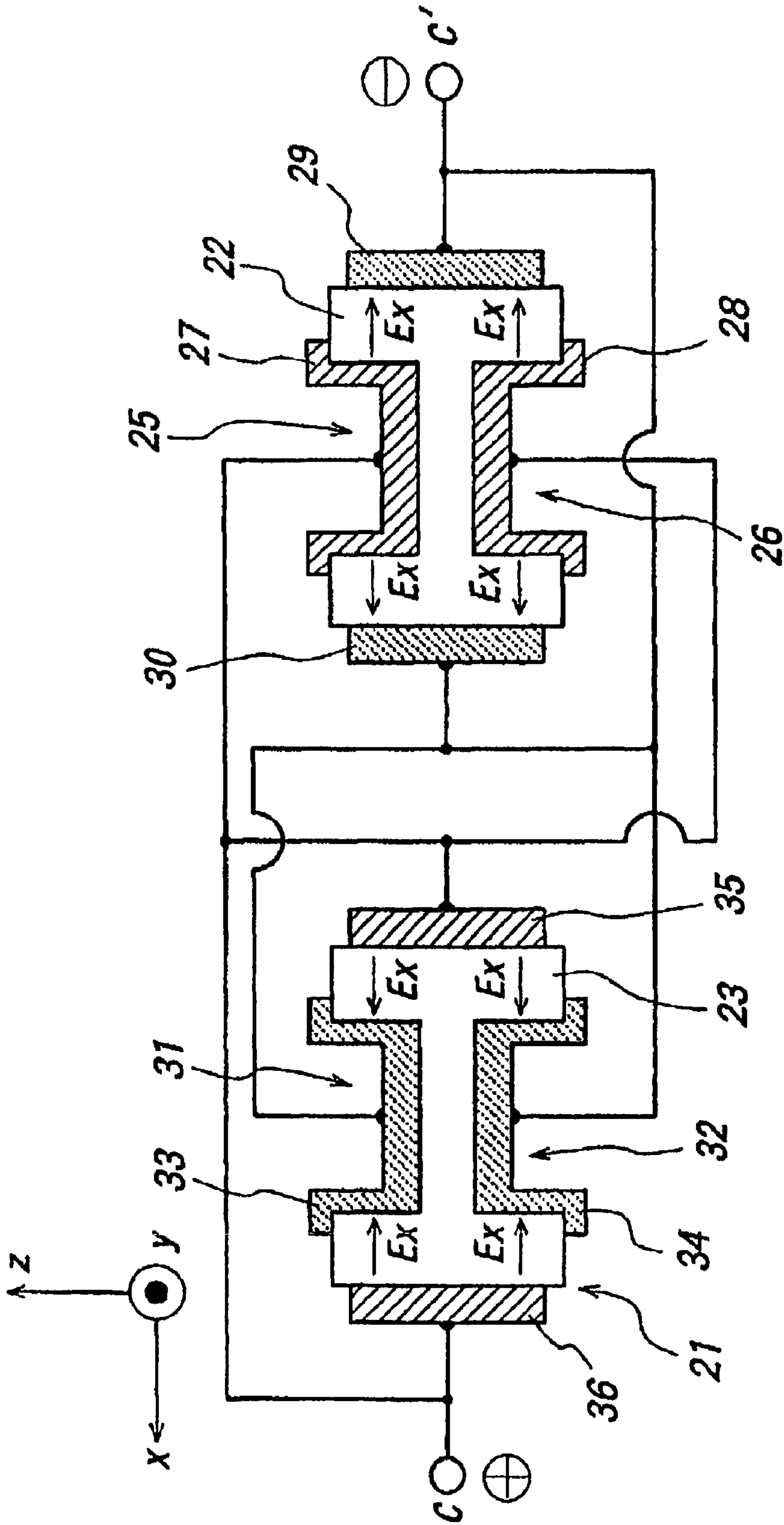
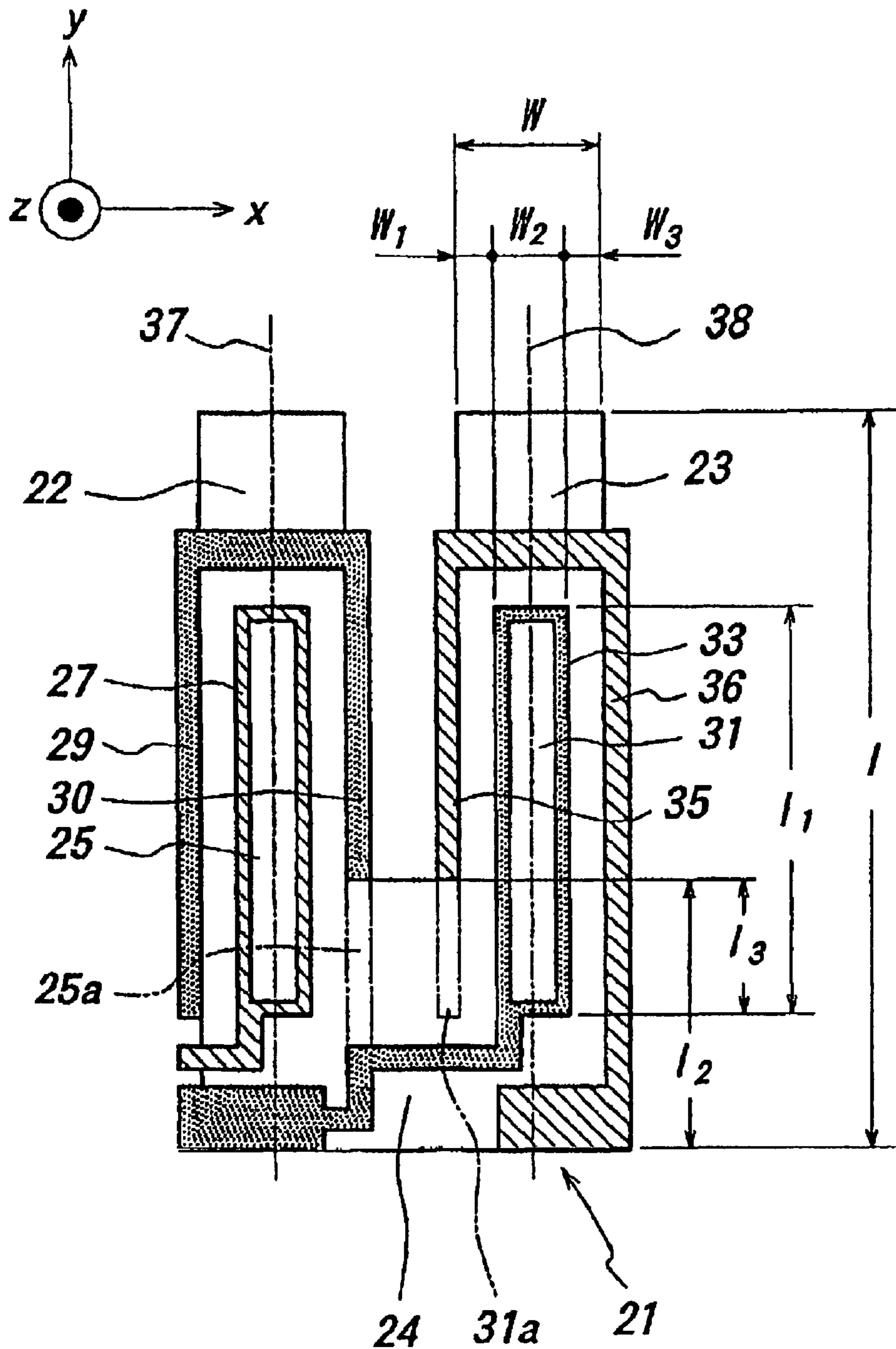

FIG. 4



**FIG. 5**

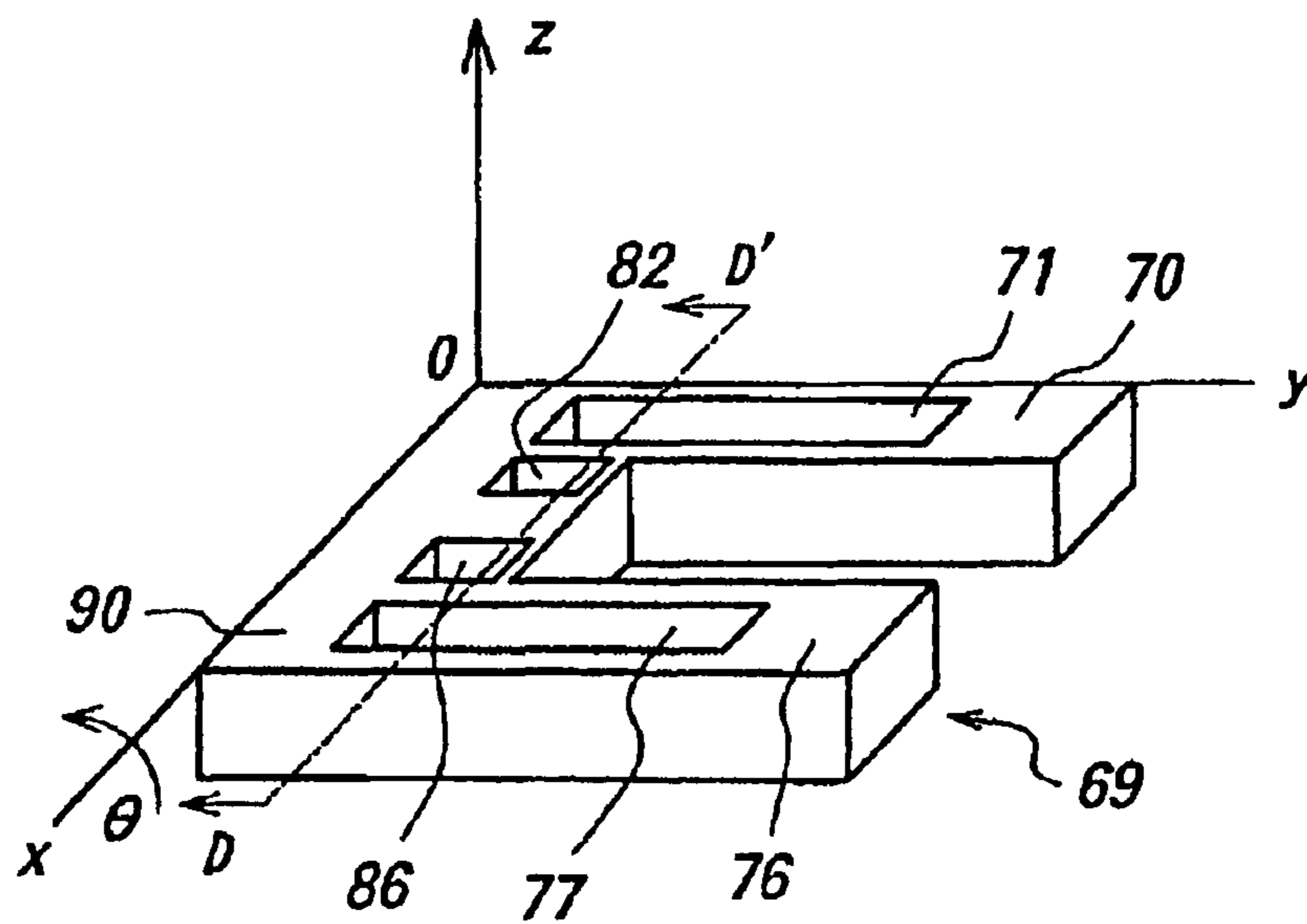

FIG. 6

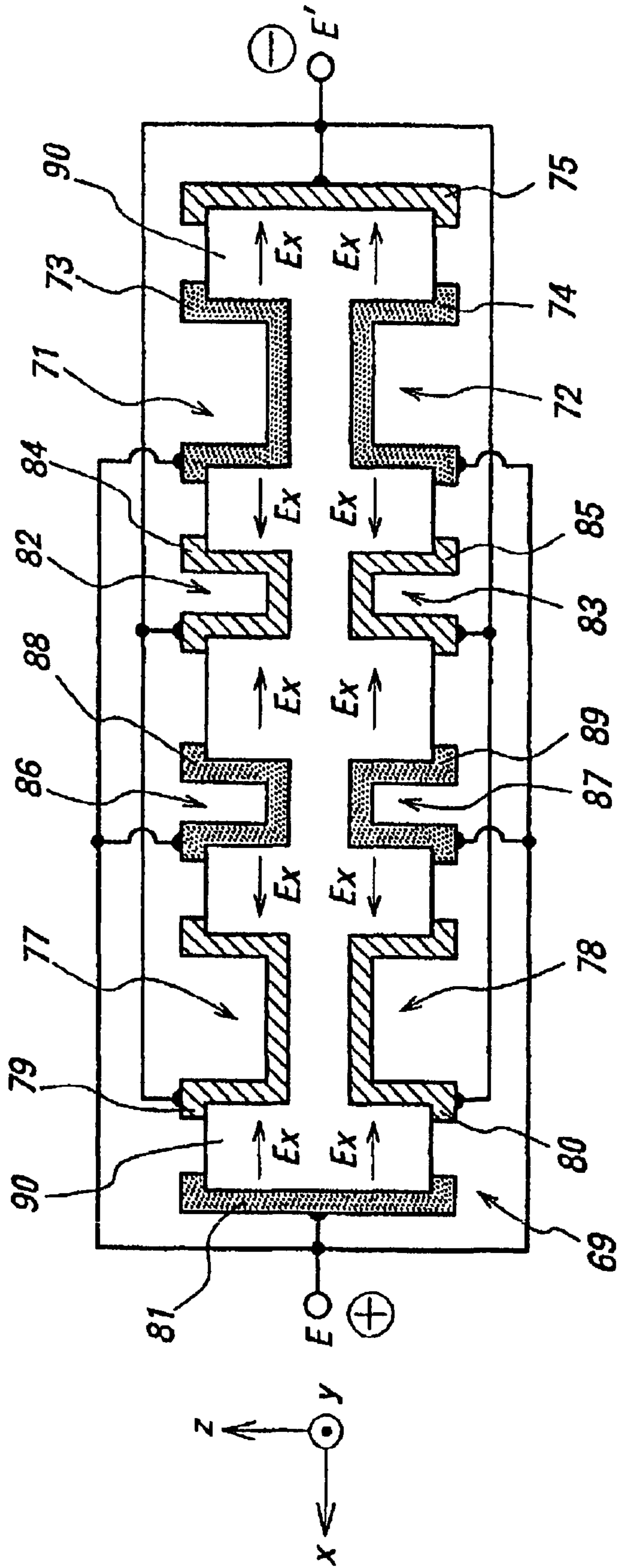
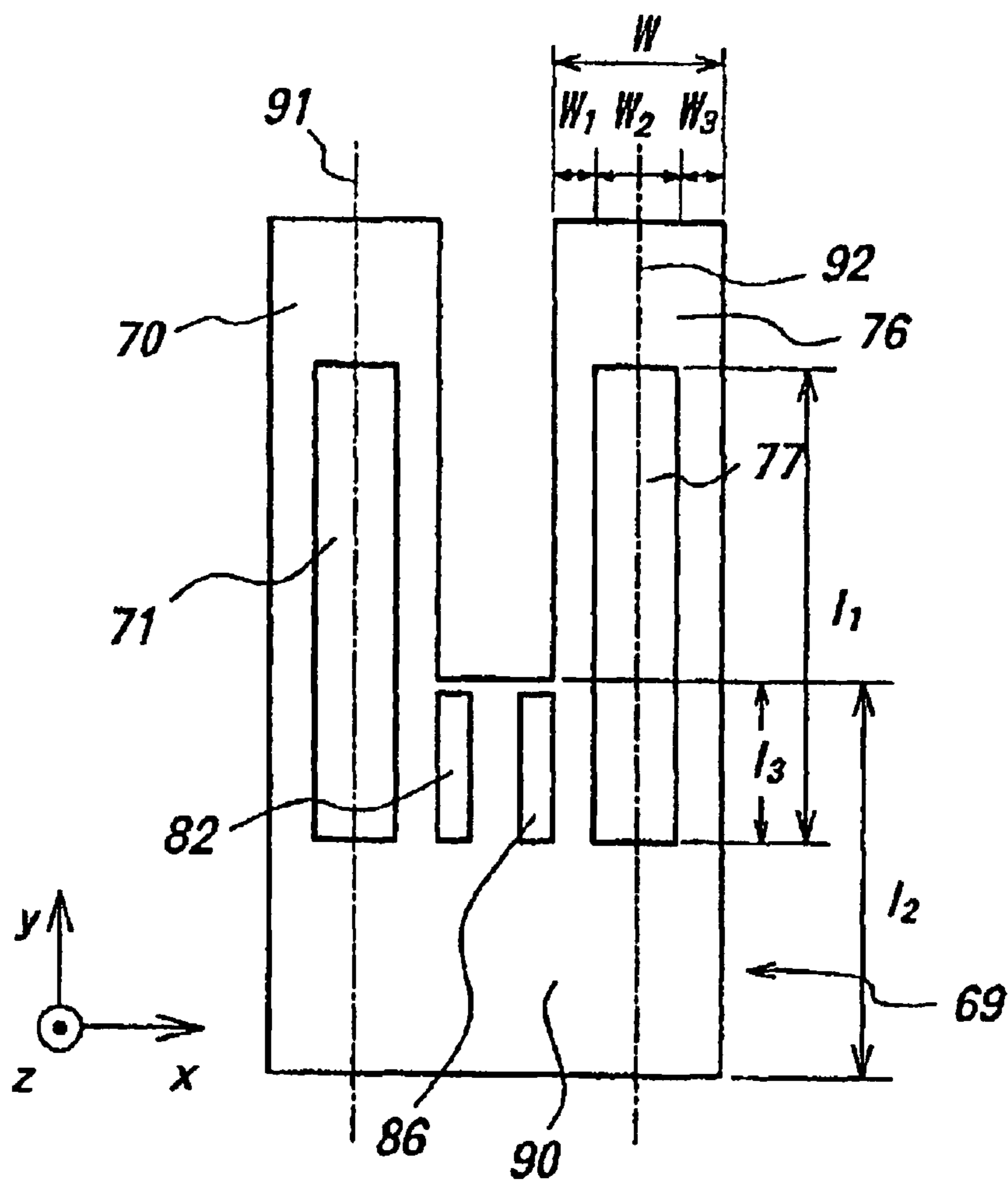
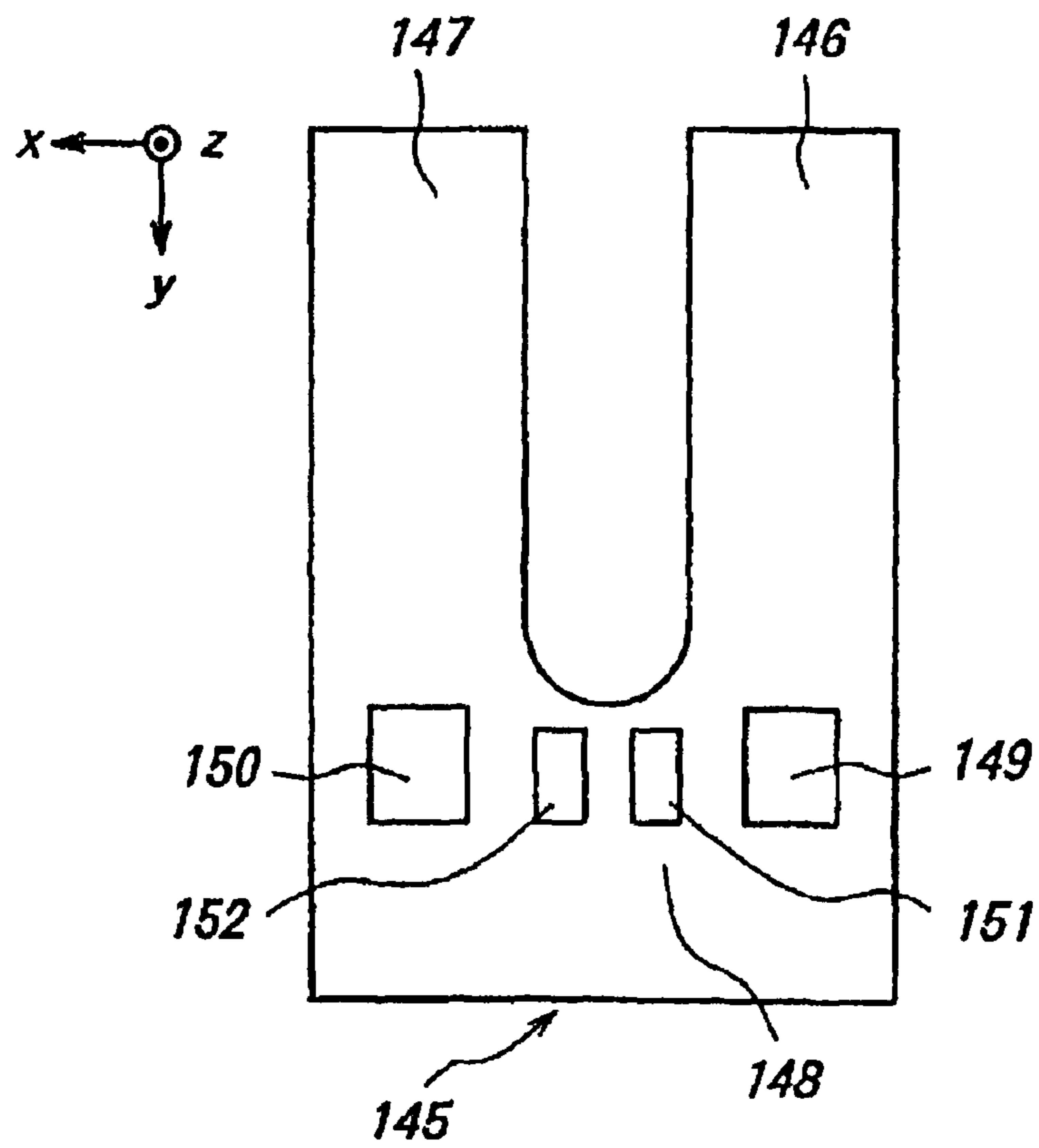

FIG. 7





**FIG. 8**



**FIG. 9**

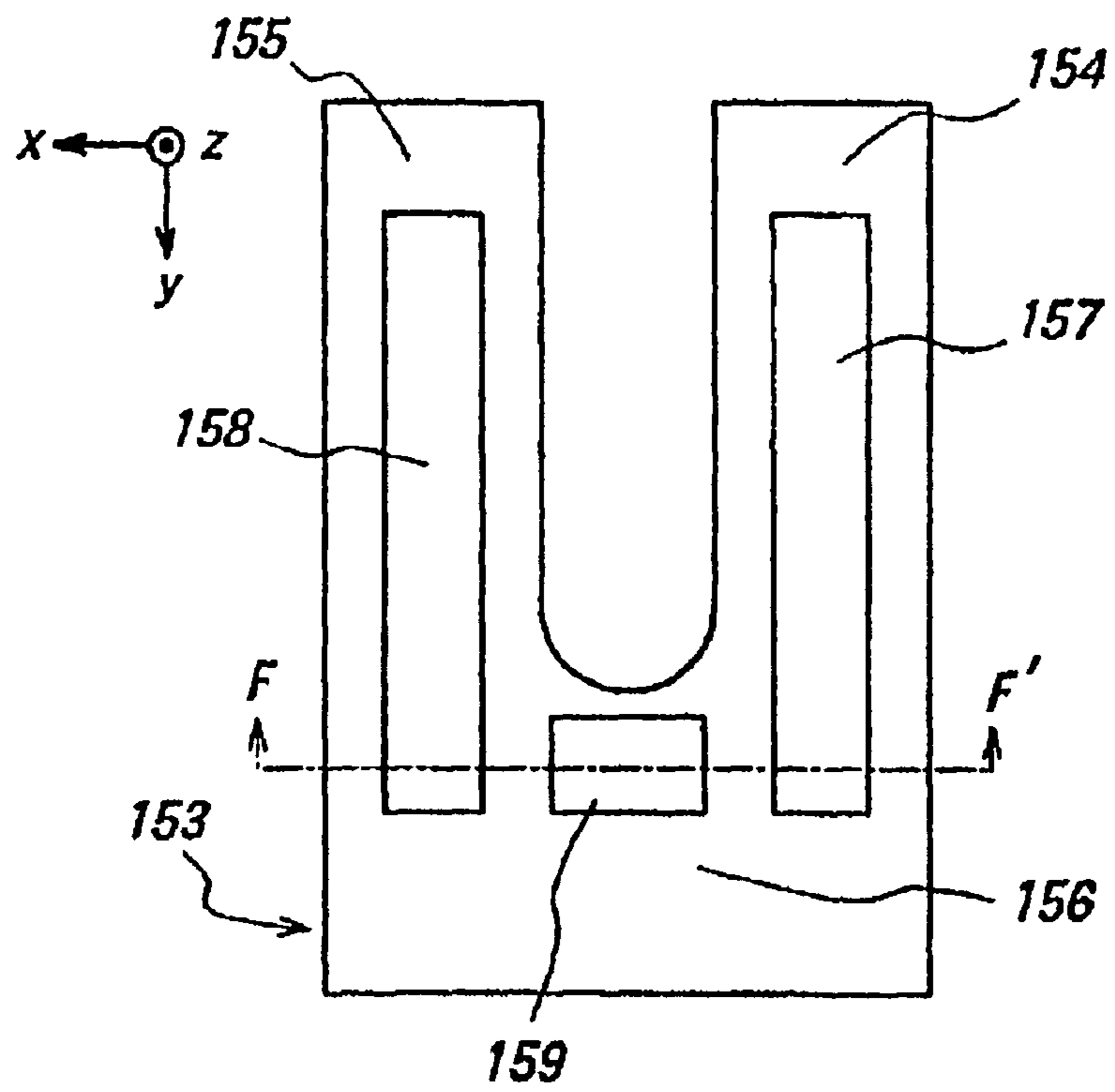
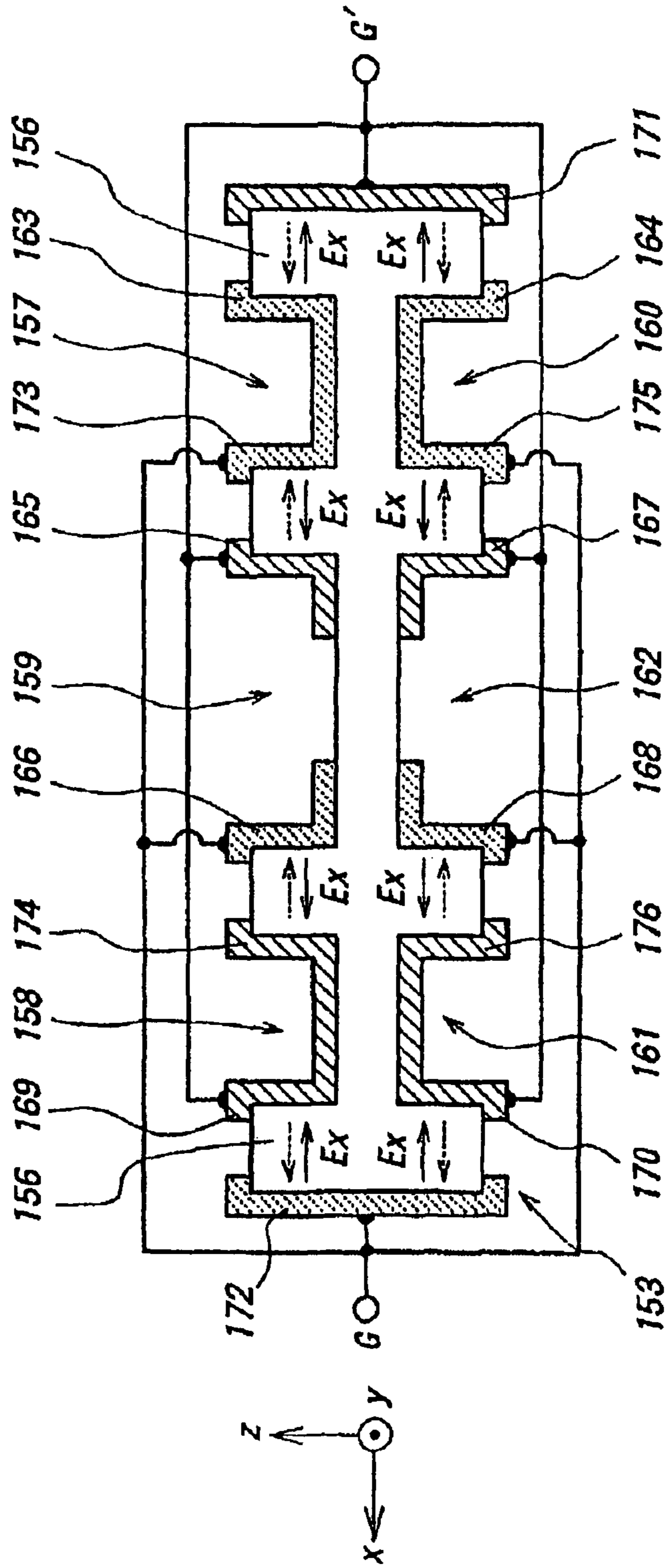
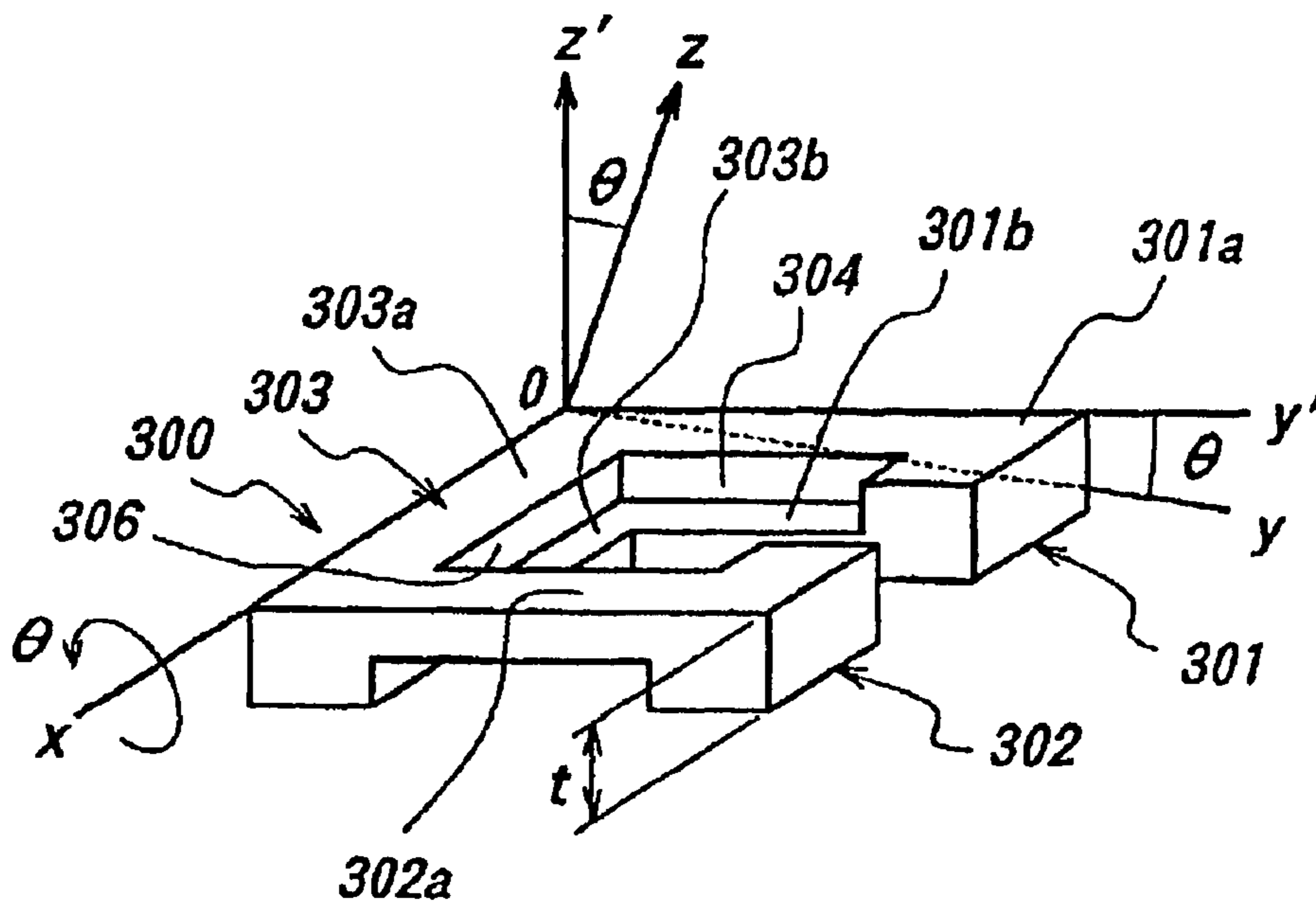

FIG. 10



**FIG. 11**



**FIG. 12**

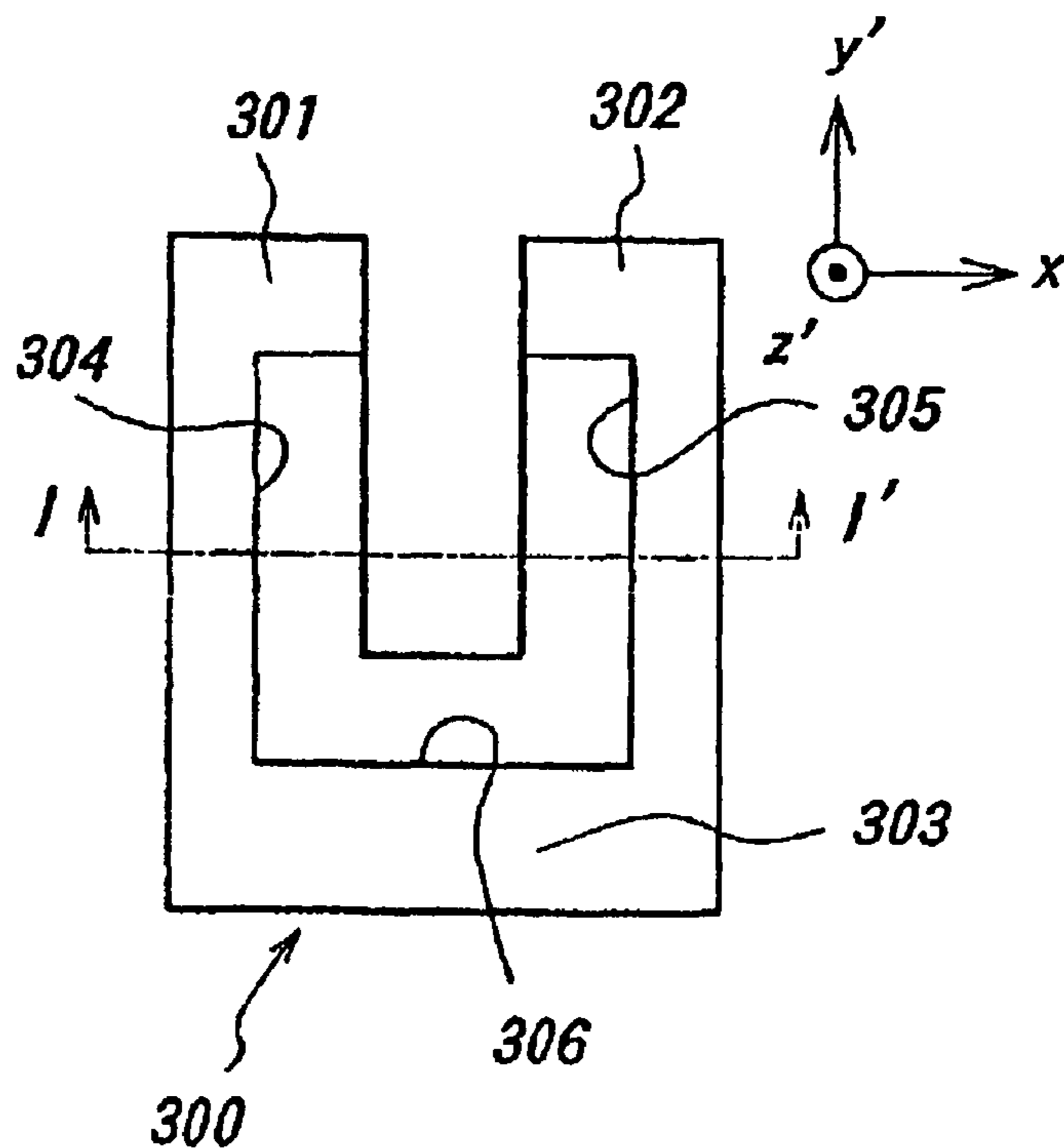
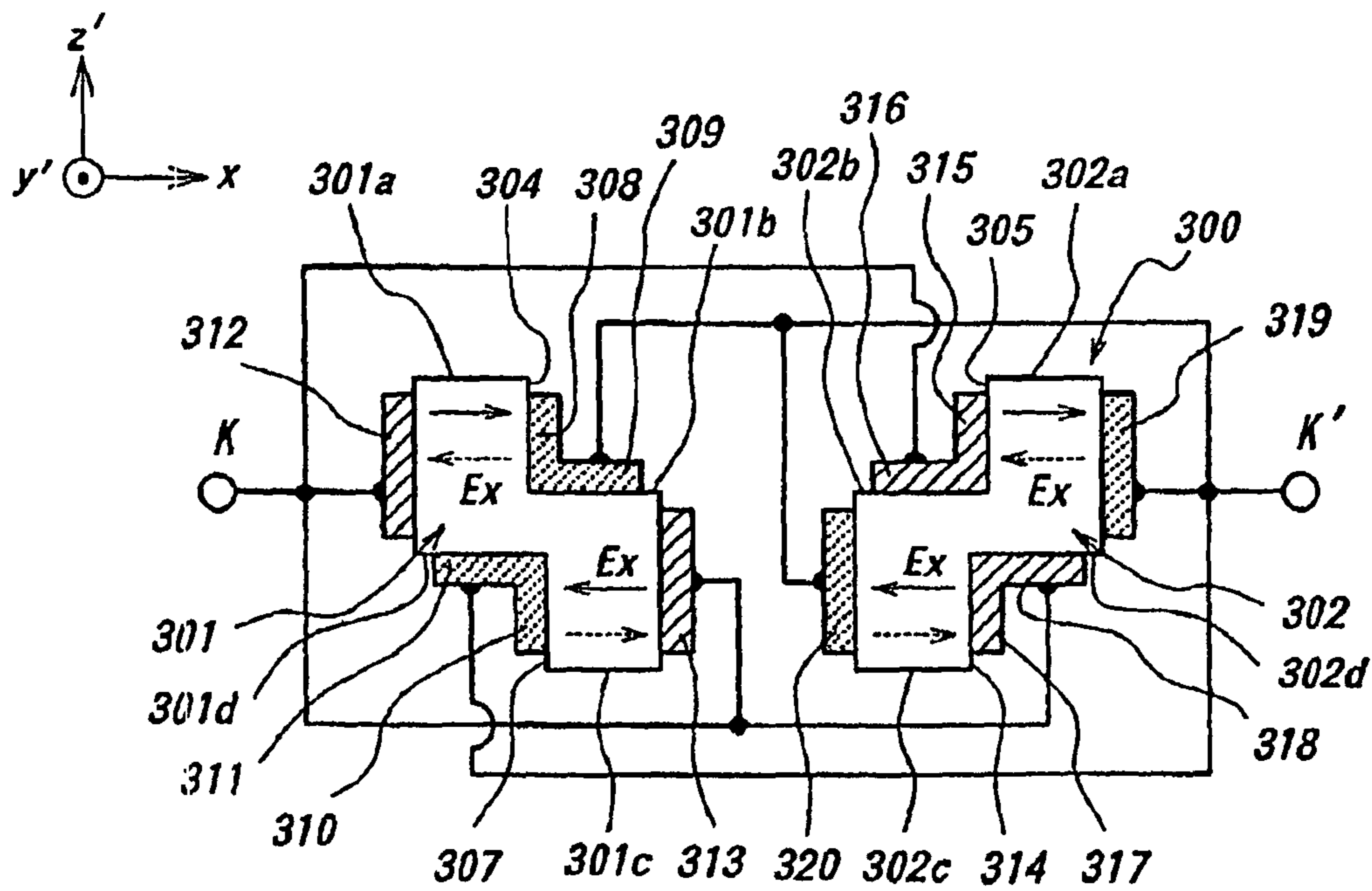
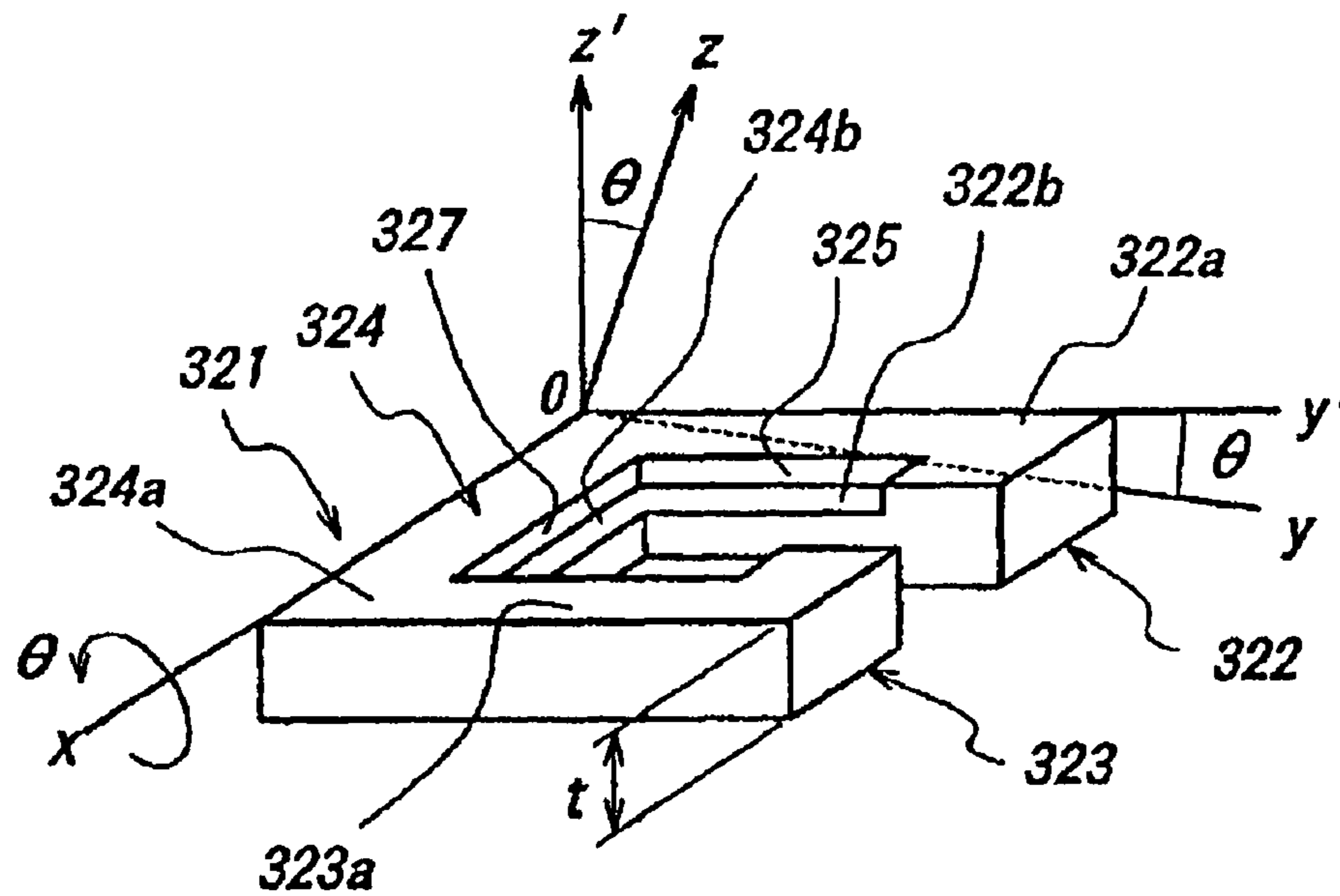

FIG. 13



**FIG. 14**



**FIG. 15**

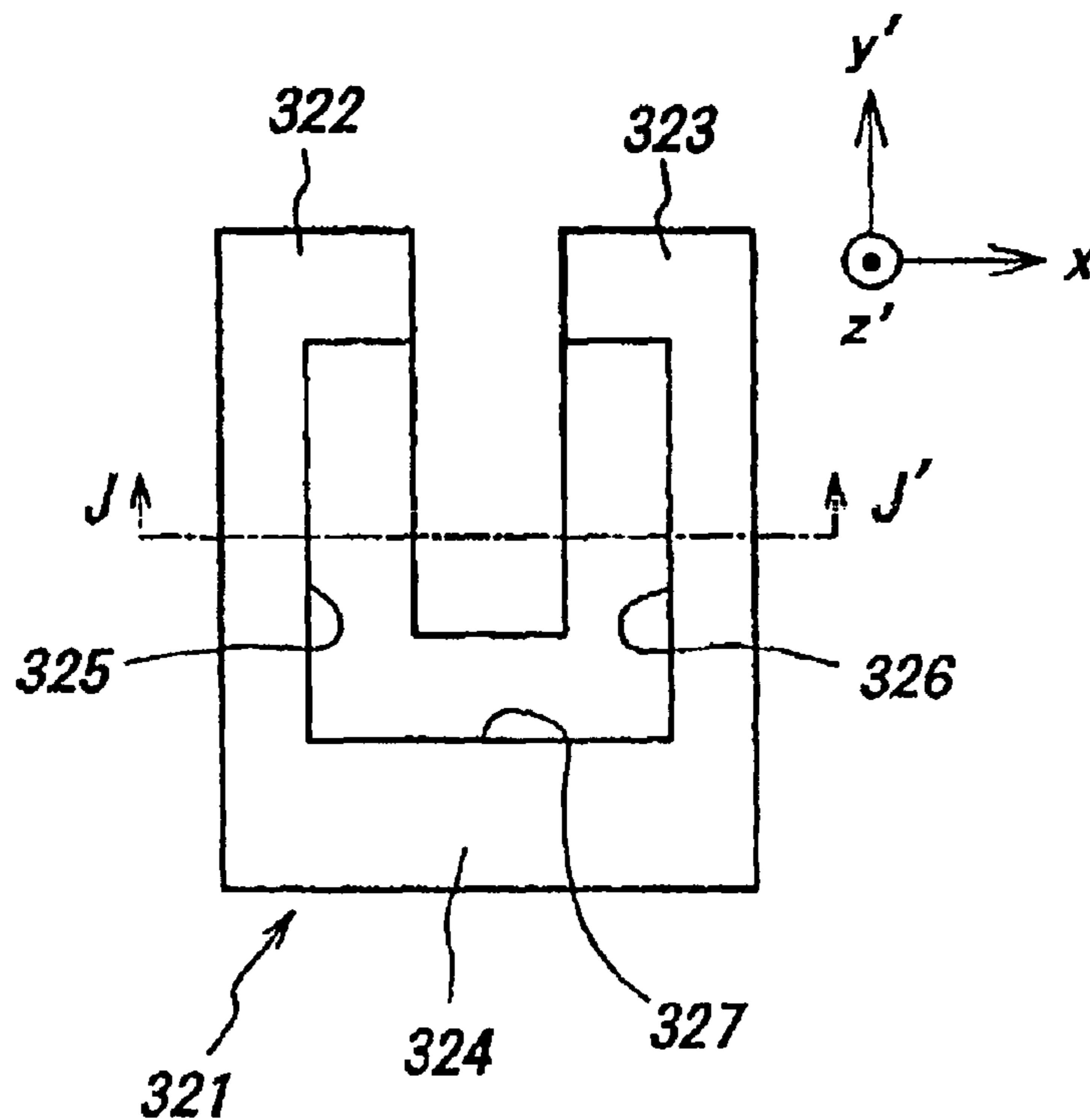
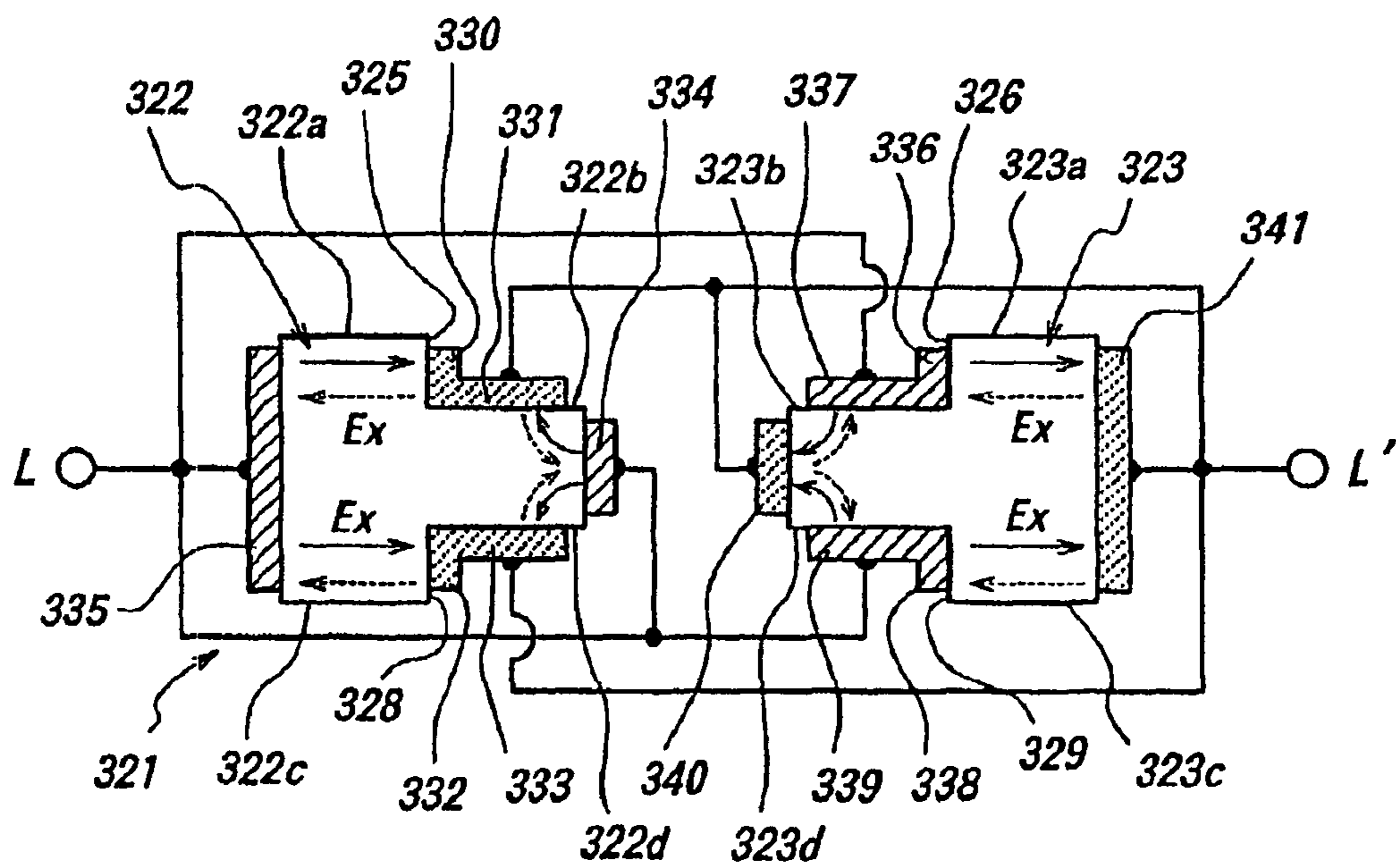
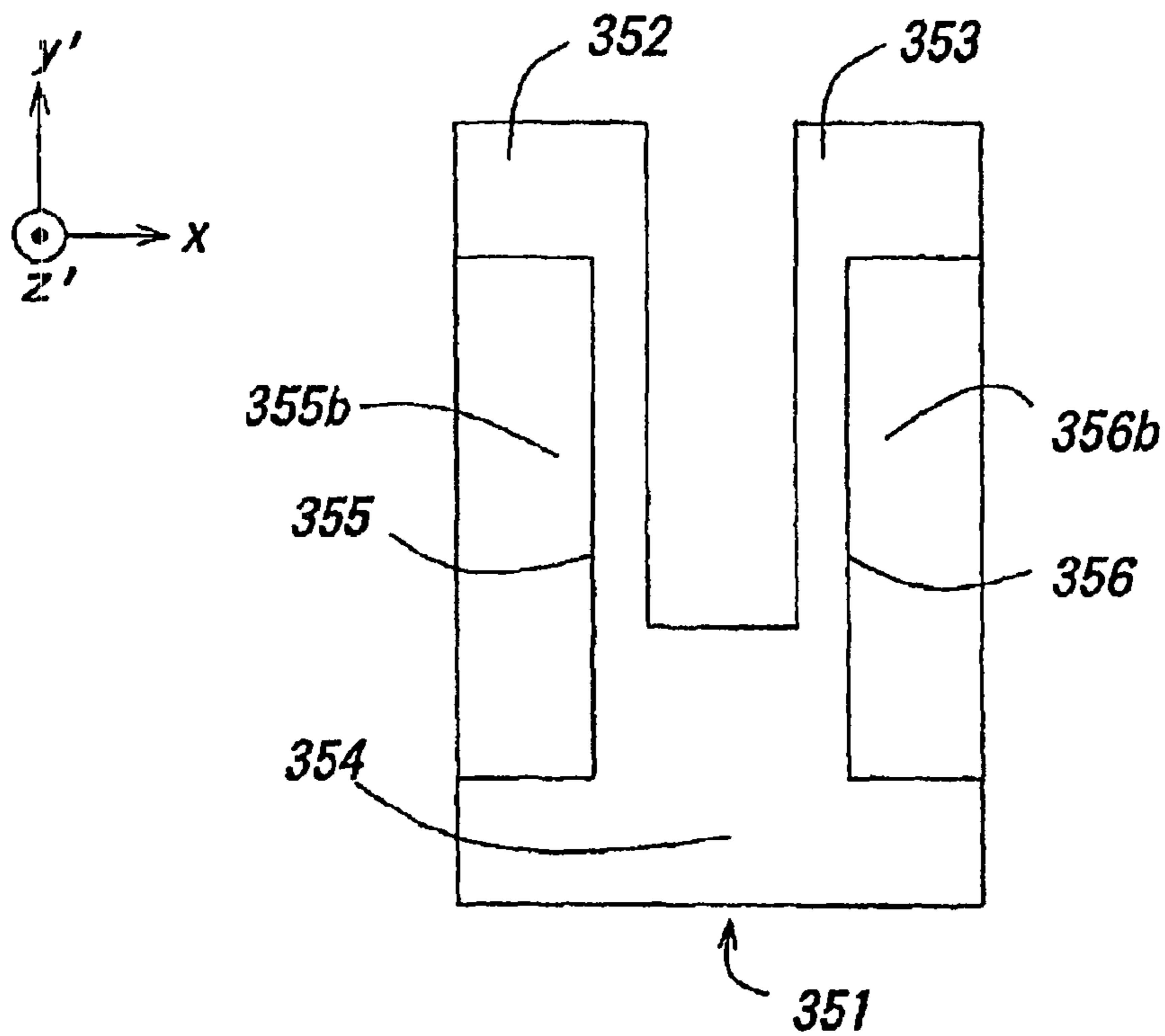

FIG. 16



**FIG. 17**



**FIG. 18**

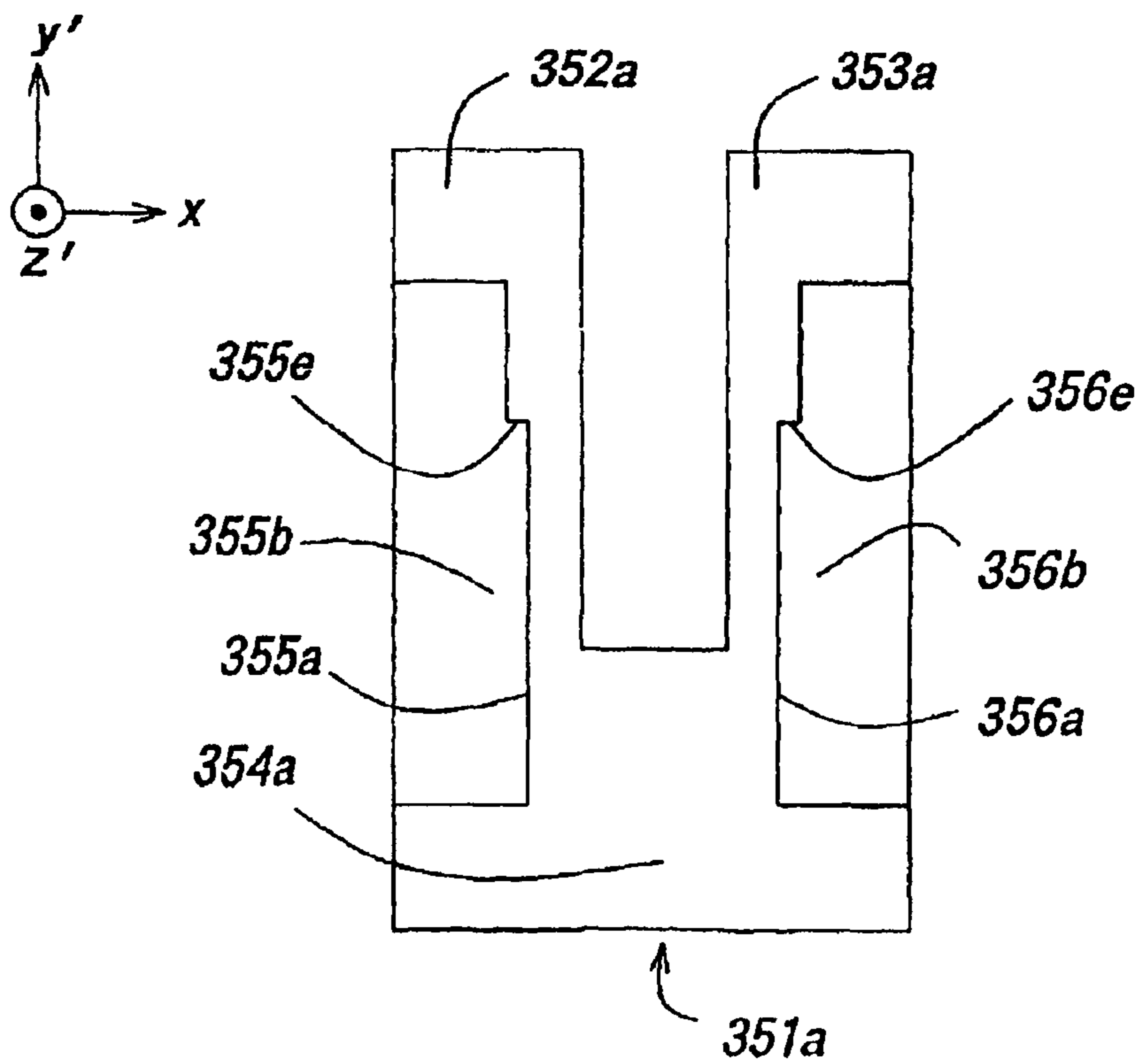



**FIG. 19**

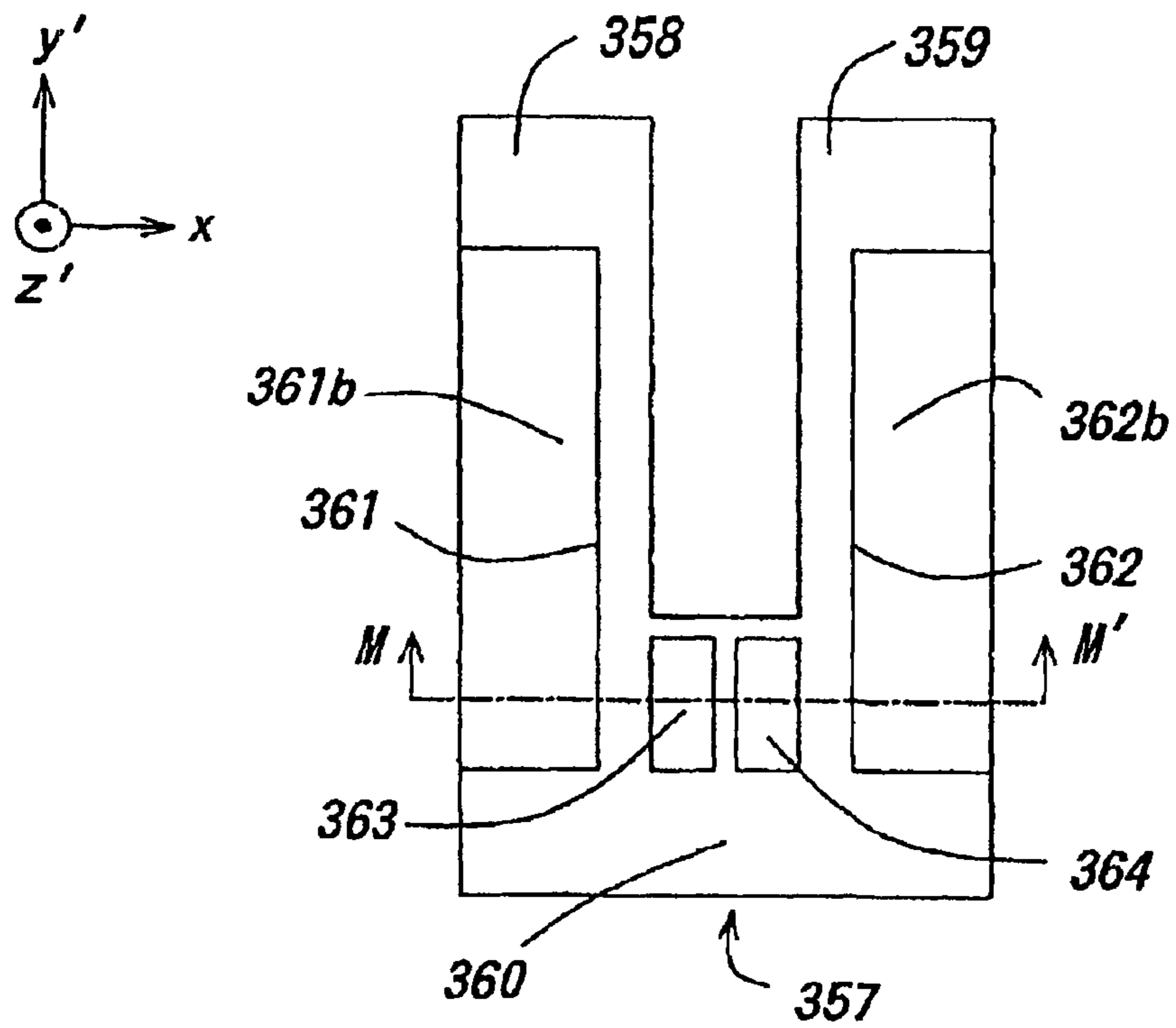
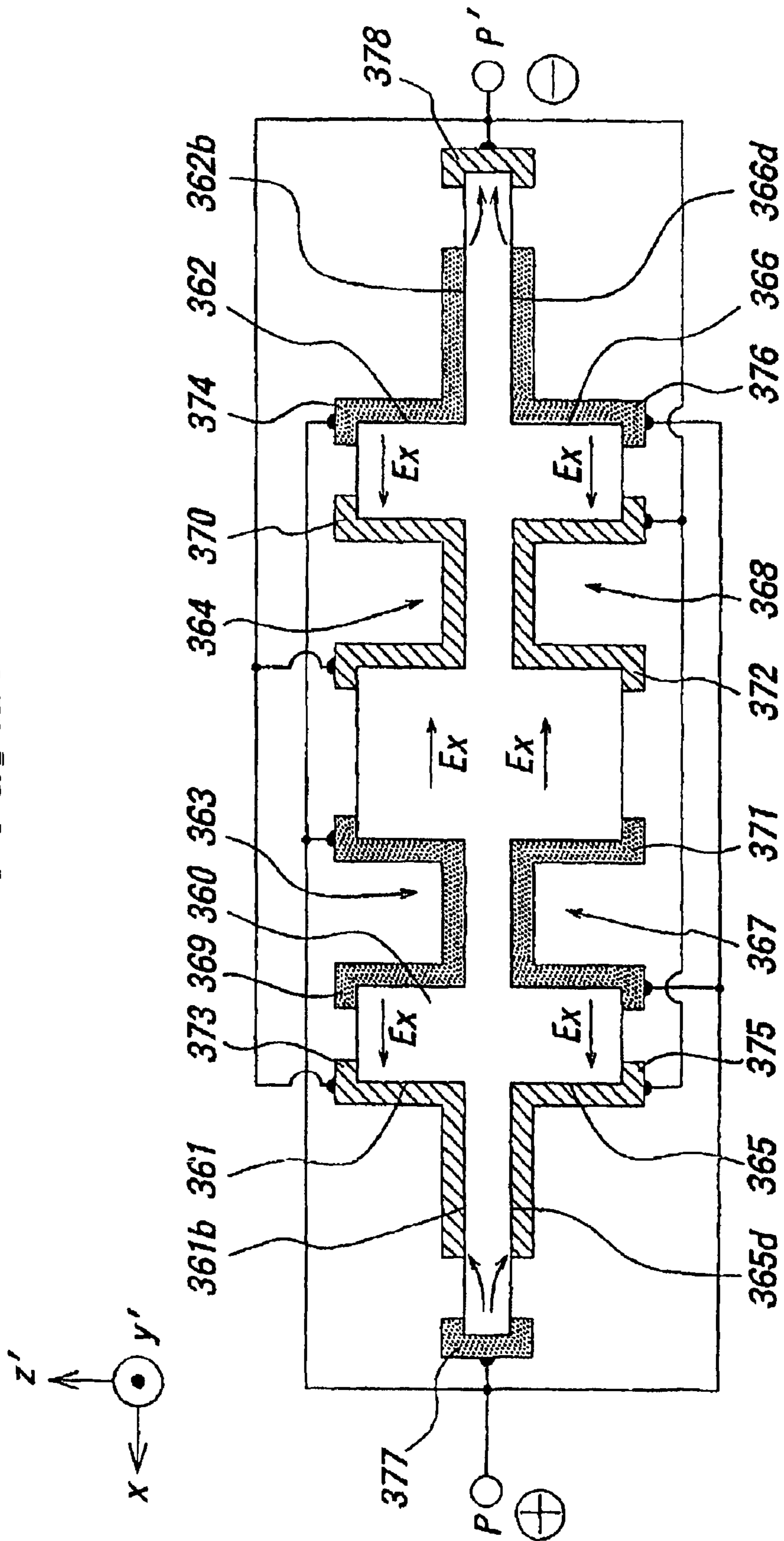
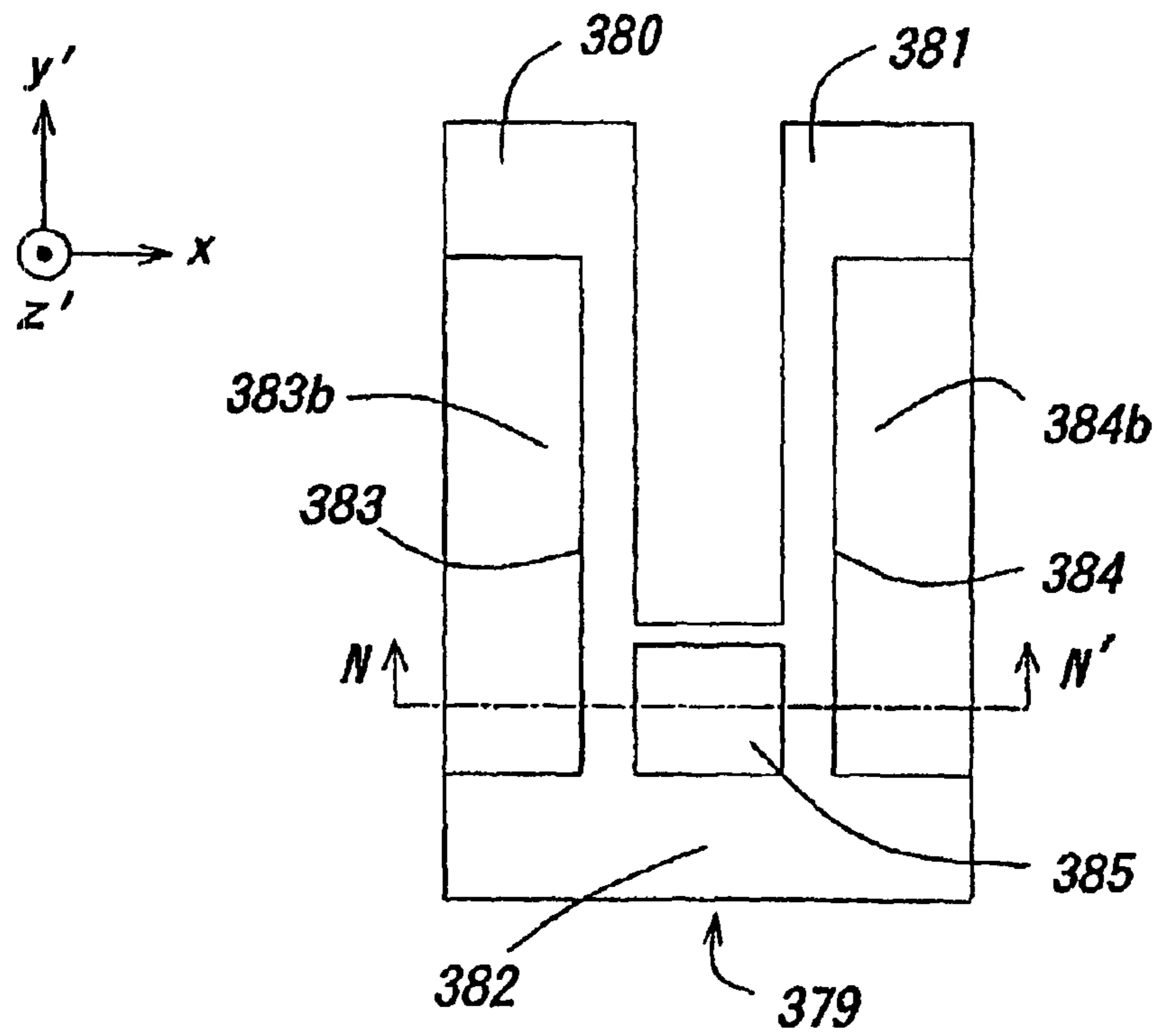

FIG. 20



**FIG. 21**



**FIG. 22**

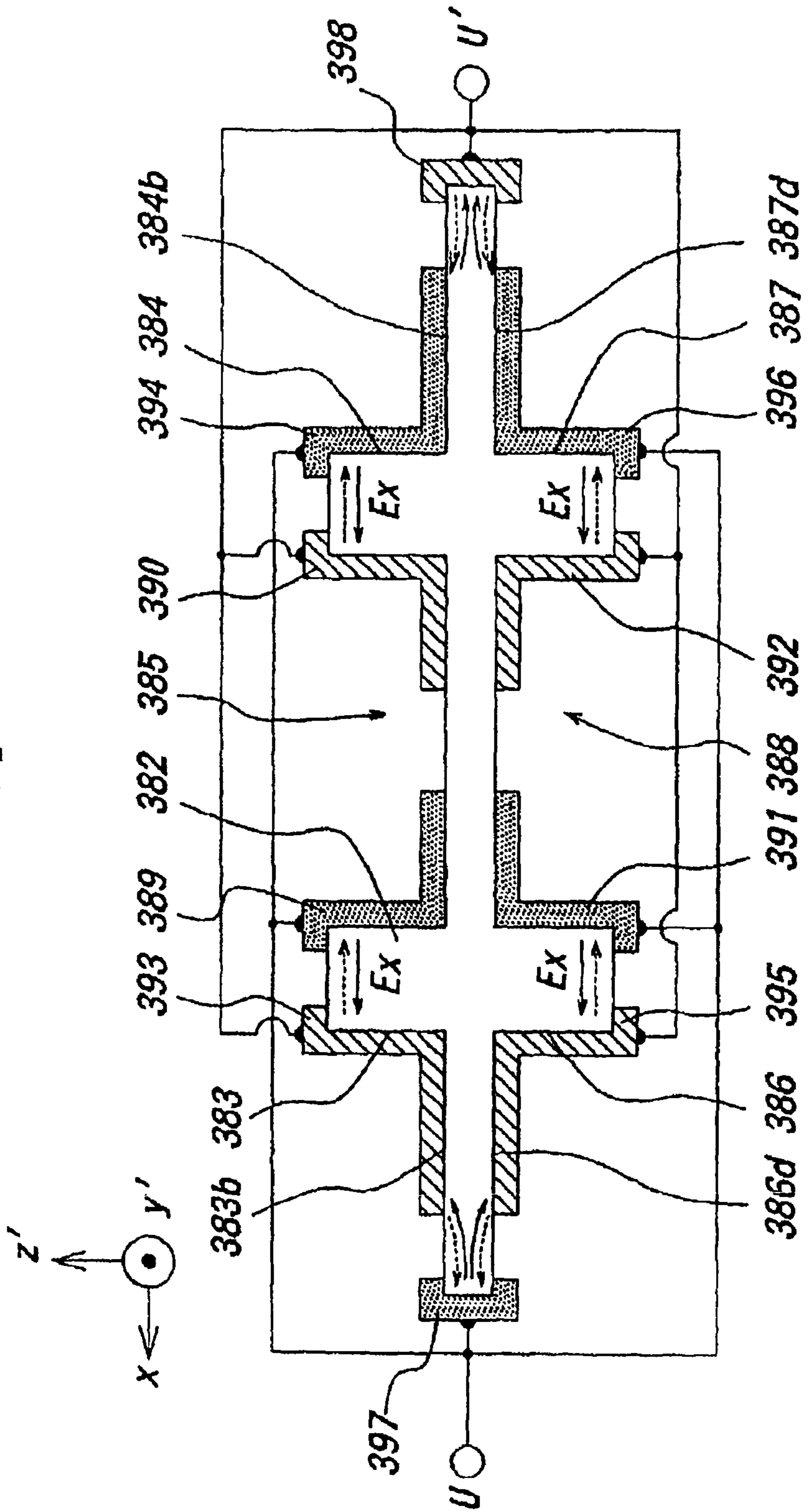
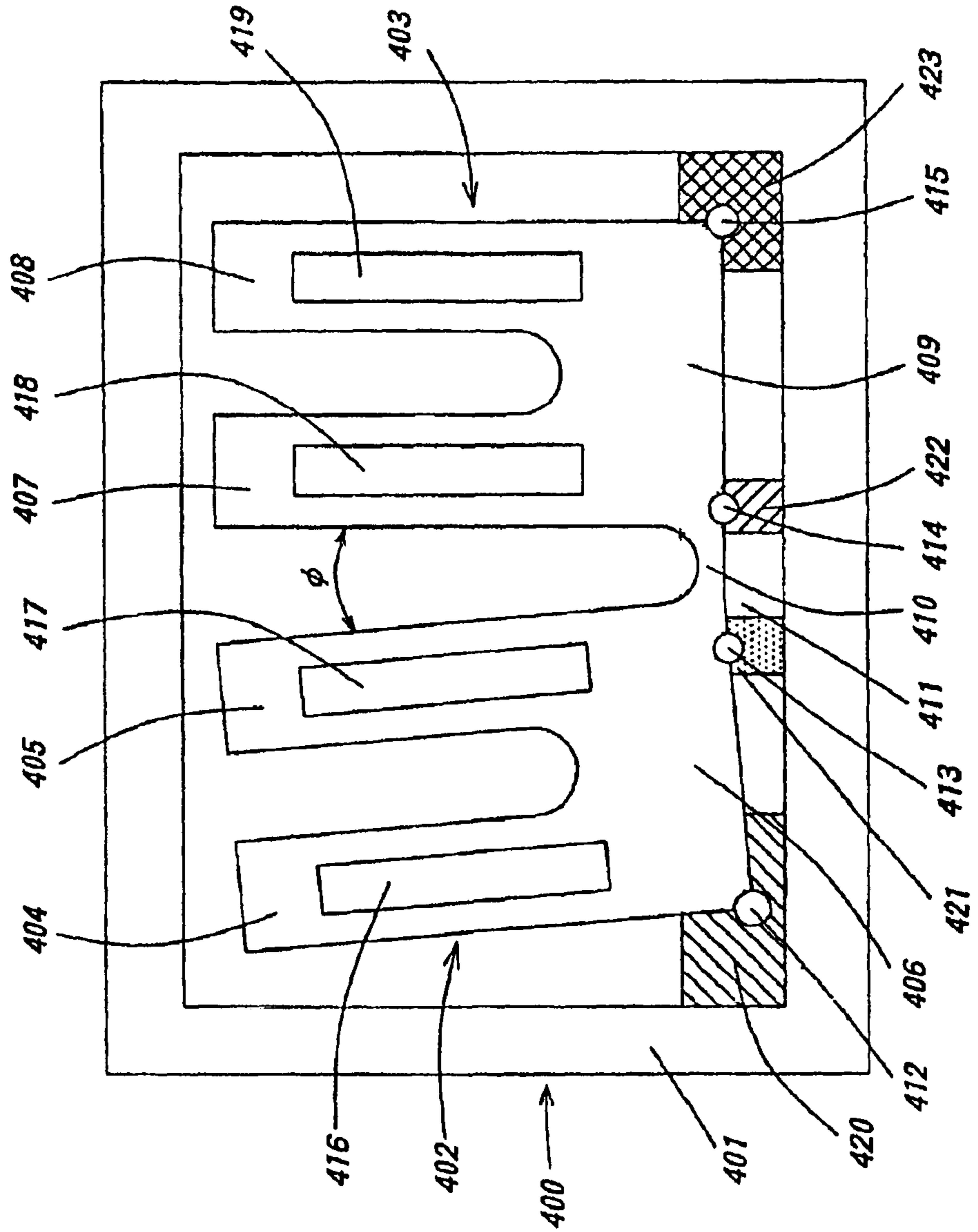
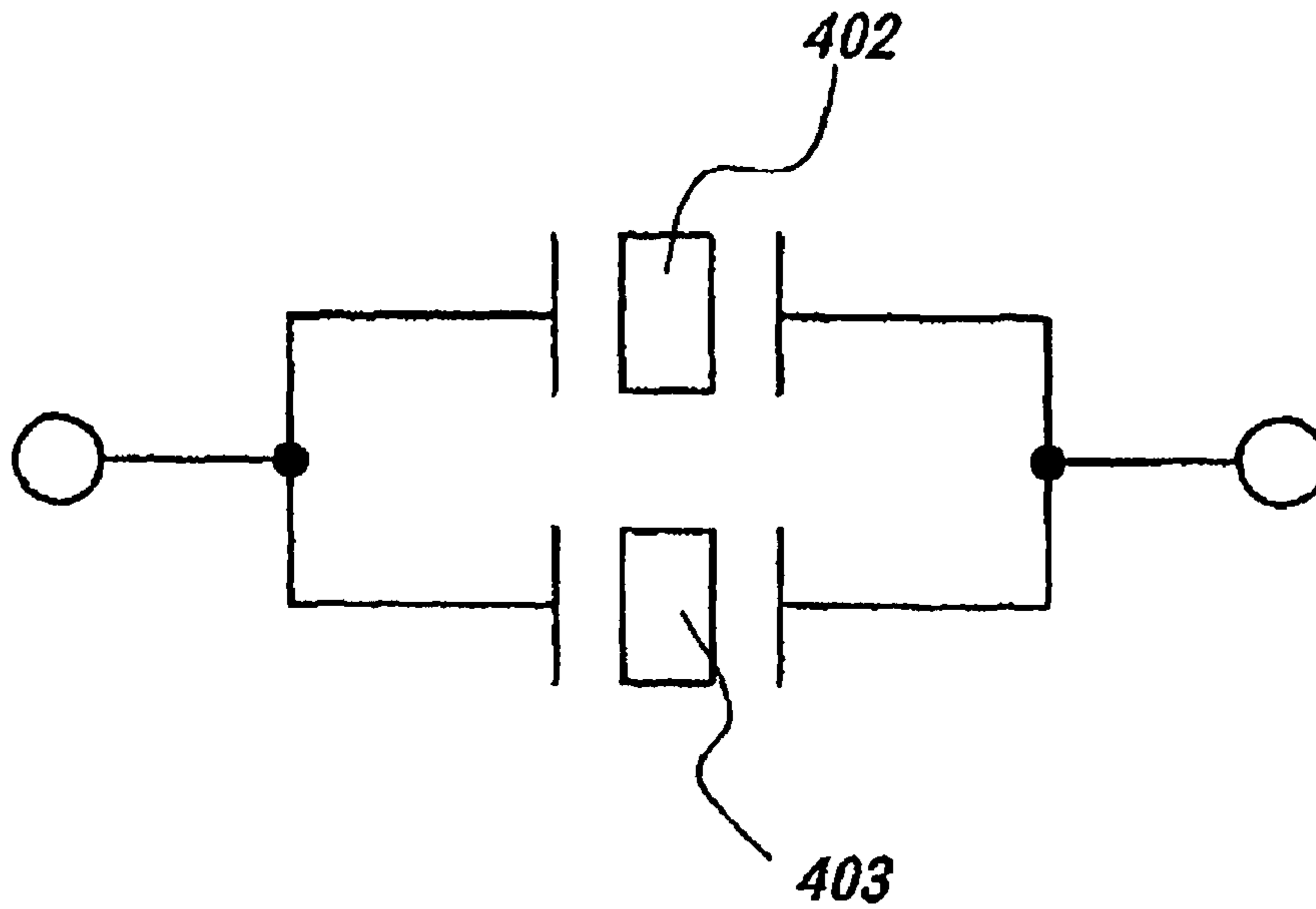

FIG. 23



**FIG. 24**



**FIG. 25**

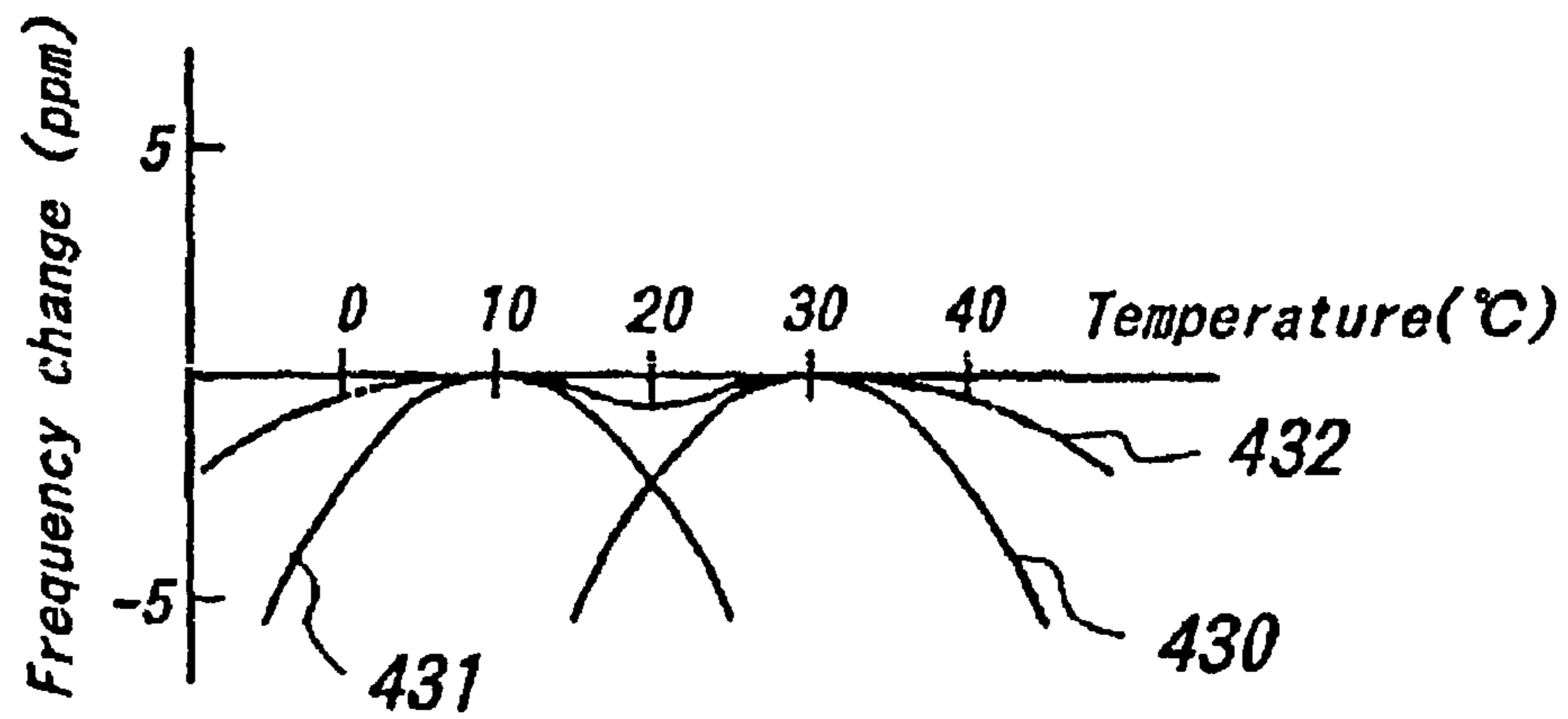

FIG. 26

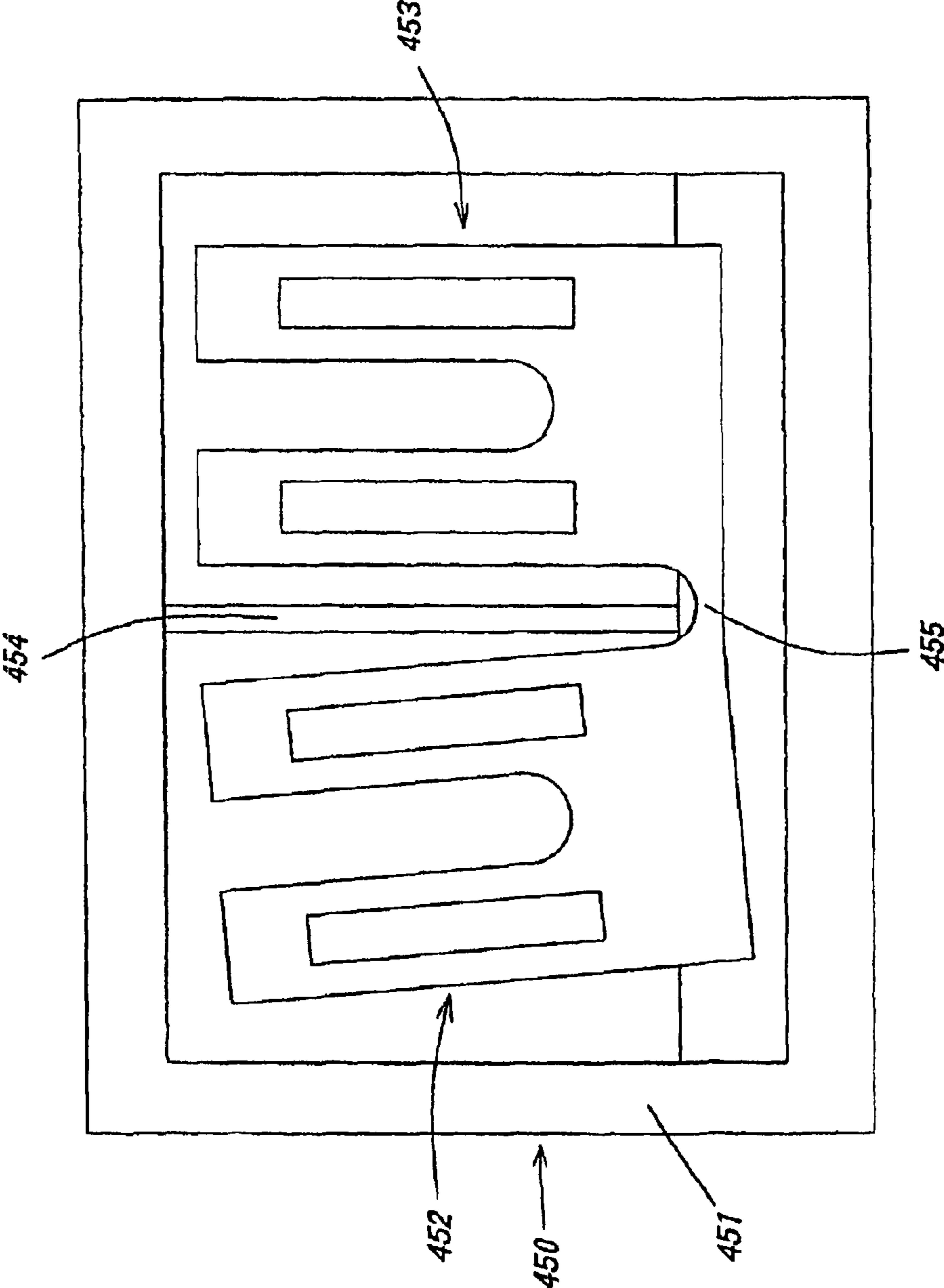
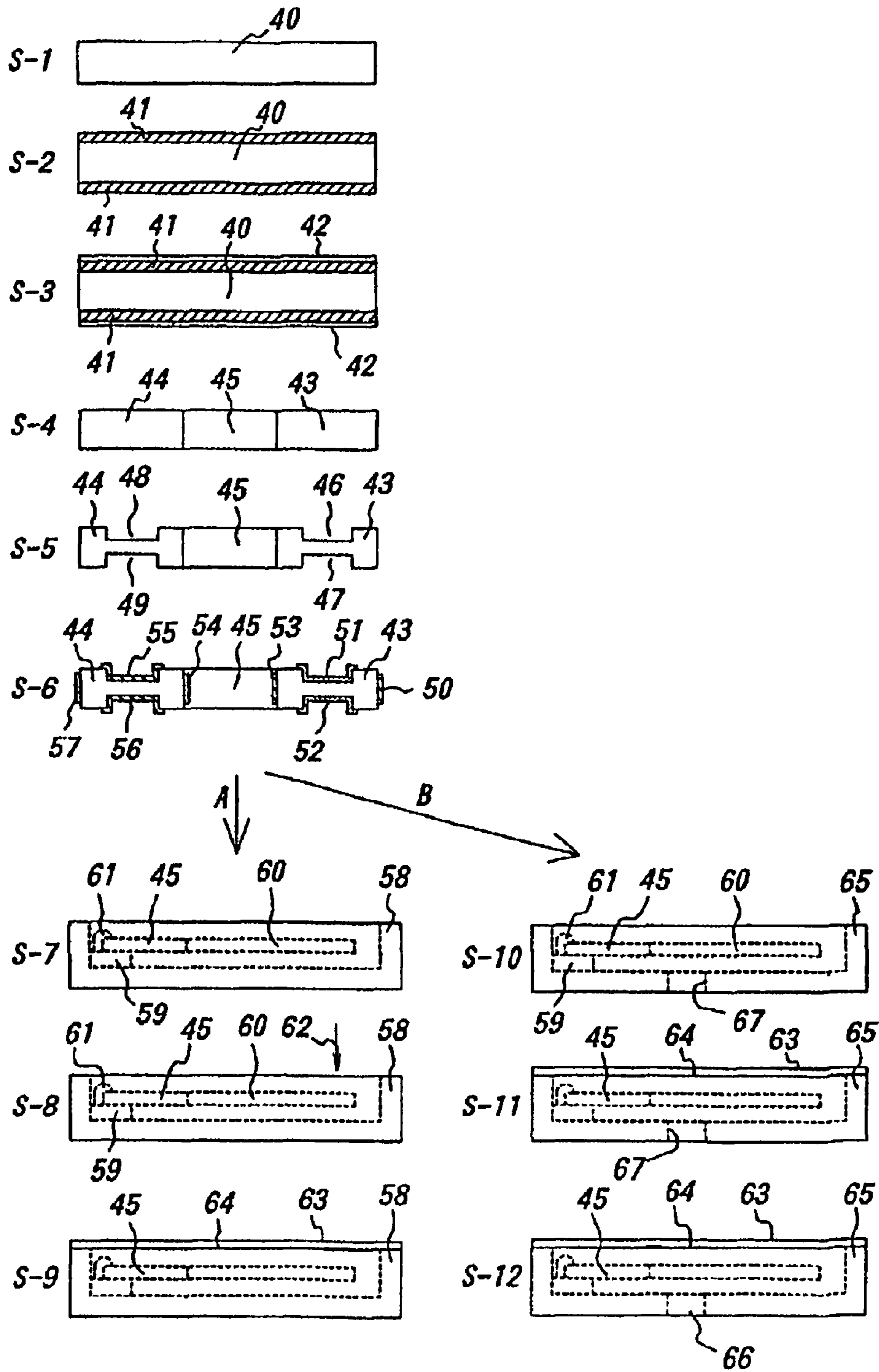

FIG. 27





**FIG. 28a**

*Prior Art*

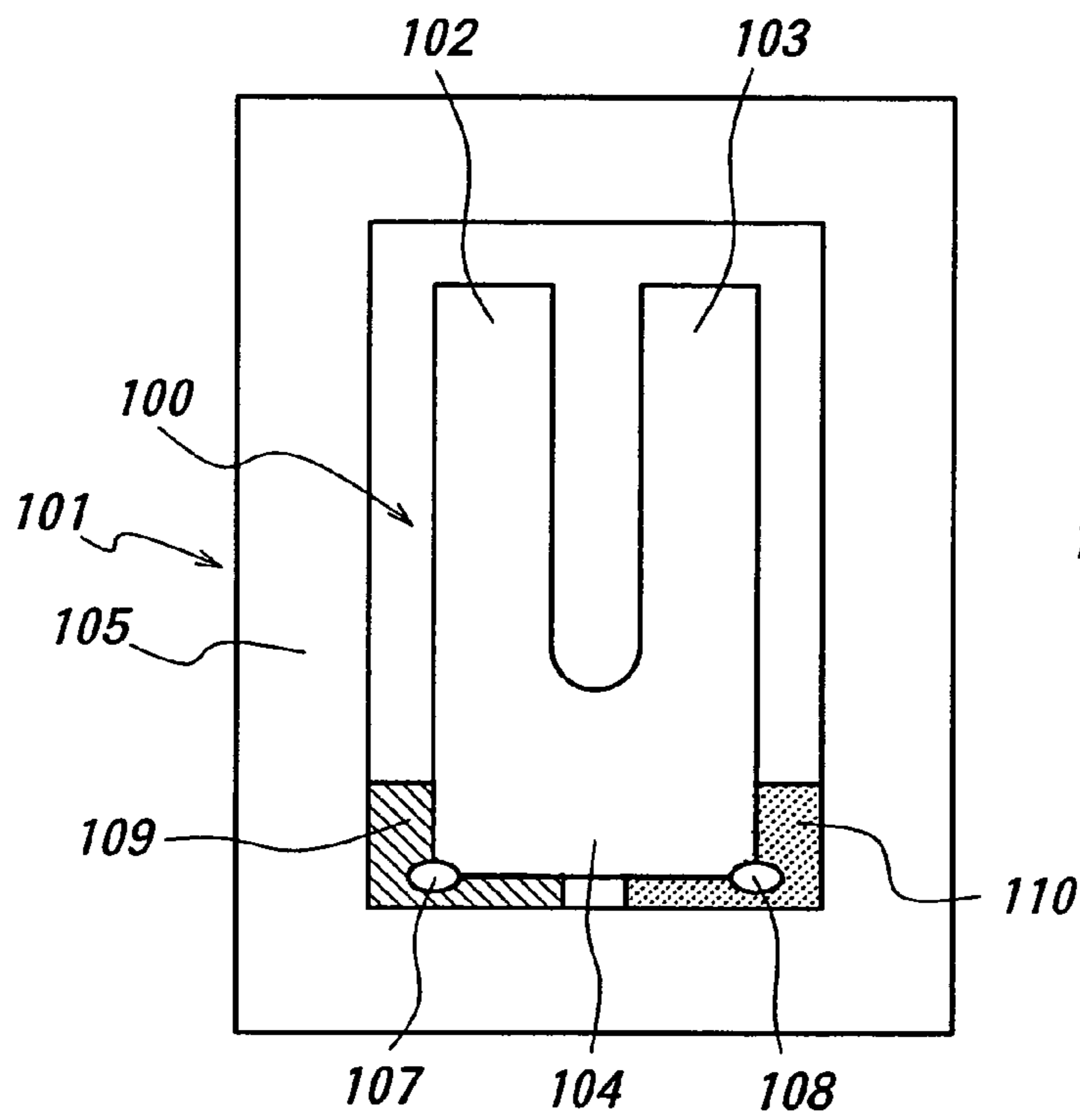

**FIG. 28b**

*Prior Art*

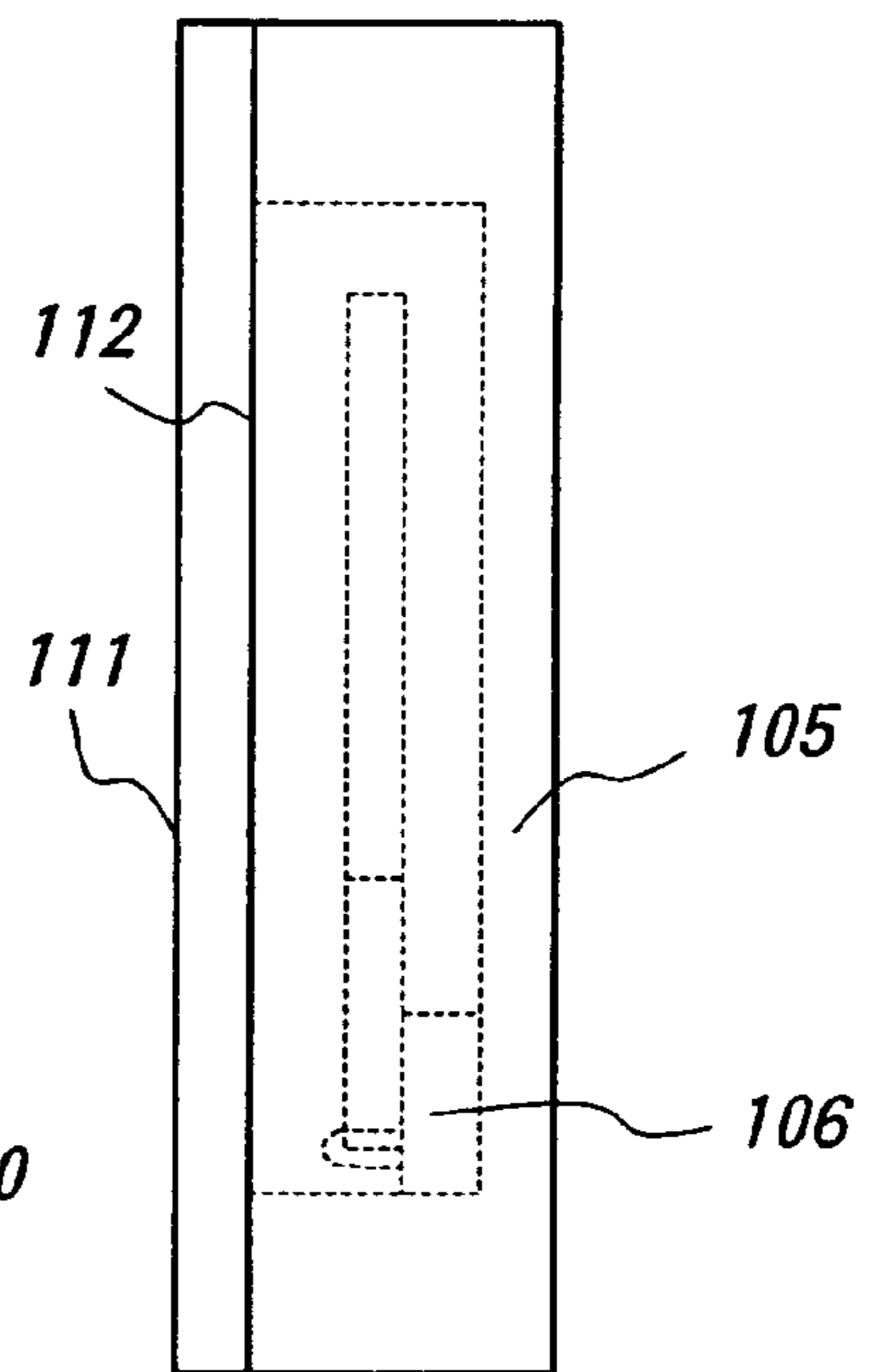

**FIG. 29**

*Prior Art*

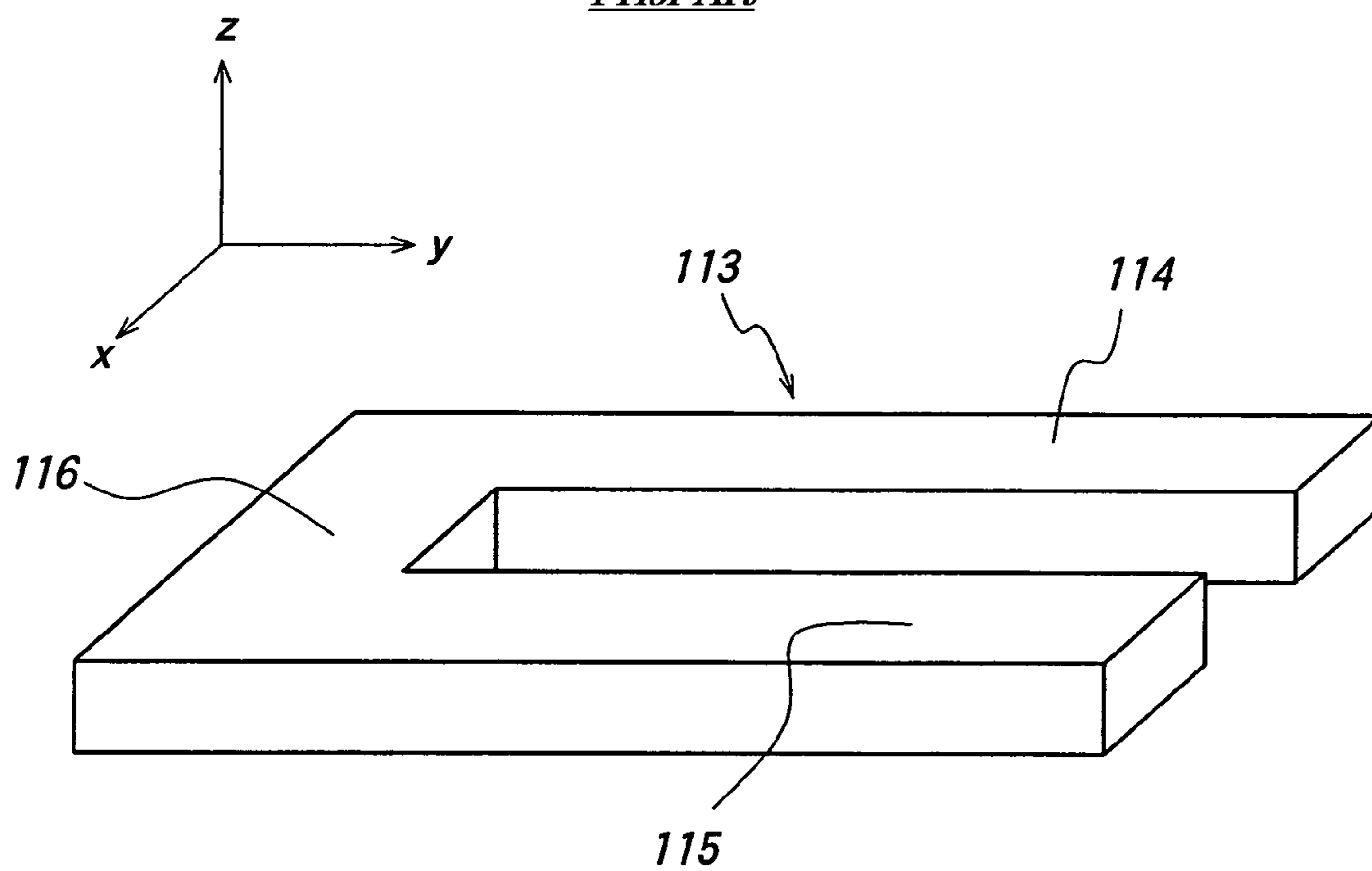
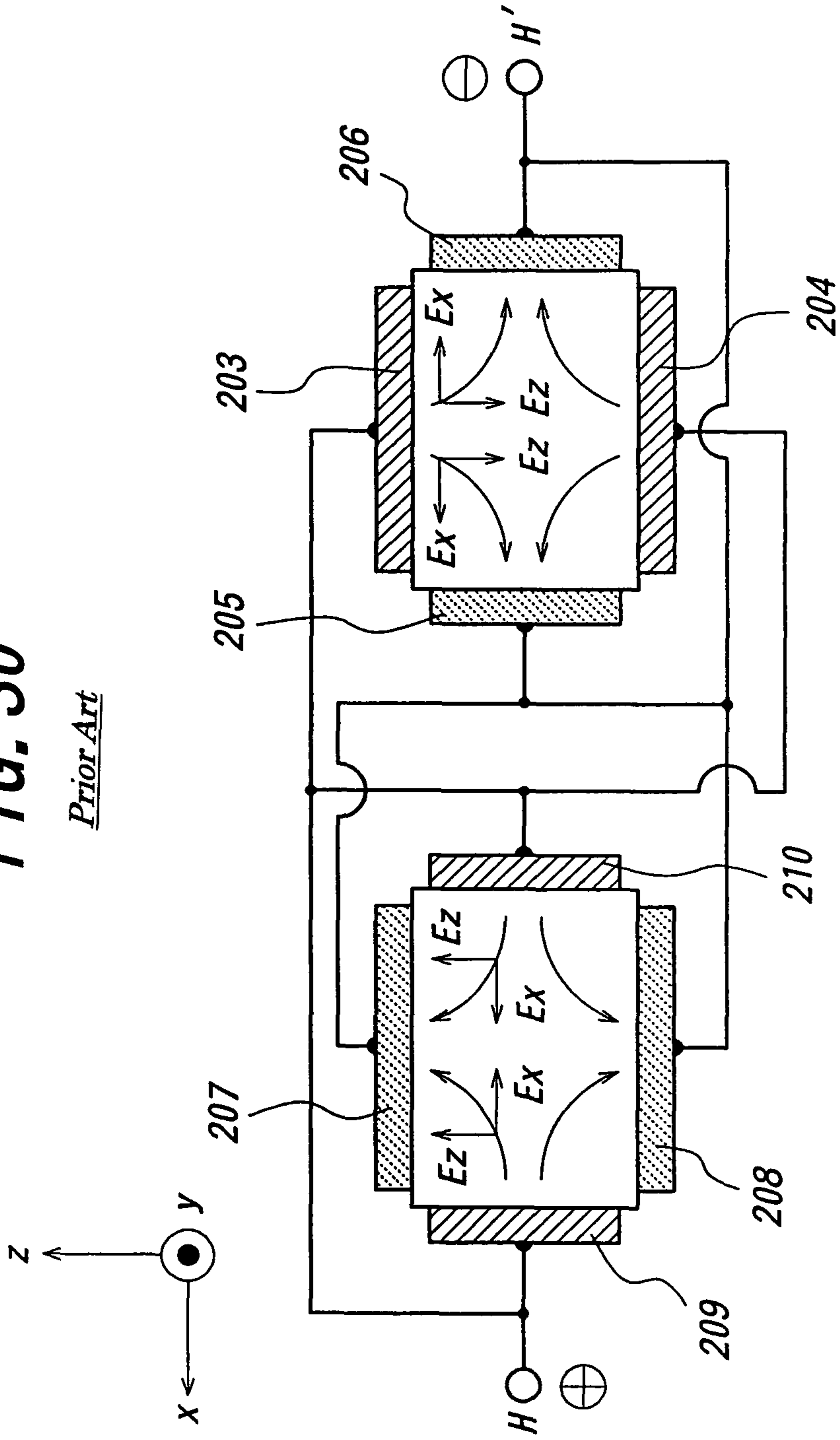

FIG. 30

*Prior Art*



## METHOD OF MANUFACTURING A QUARTZ CRYSTAL UNIT

**Matter enclosed in heavy brackets [ ] appears in the original patent but forms no part of this reissue specification; matter printed in italics indicates the additions made by reissue.**

### BACKGROUND OF THE INFORMATION

The present invention relates to a quartz crystal unit comprising a flexural mode, tuning fork, quartz crystal resonator, a case and a lid, and its manufacturing method.

### BACKGROUND INFORMATION

Quartz crystal units with a tuning fork, quartz crystal resonator which vibrates in flexural mode are widely used as a time standard in consumer products, wearable equipment and communication equipment (such as wristwatches, cellular phones, and pagers). Recently, because of miniaturization and the light weight nature of these products, a smaller quartz crystal unit with a smaller flexural mode, tuning fork, quartz crystal resonator is required with a small series resistance and a high quality factor.

FIG. 28(a) and FIG. 28(b) show a plan view and a side view of a quartz crystal unit 101 with the conventional flexural mode, tuning fork, quartz crystal resonator 100. The resonator 100 comprises tuning fork tines 102, 103 and tuning fork base 104. The base 104 is fixed at a mounting portion 106 of a case 105 by adhesives 107, 108 or solder. Also, electrodes 109 and 110 are disposed on the mounting portion 106 and two electrode terminals are constructed. In addition, the case 105 and the lid 111 are connected via a metal 112. The conventional quartz crystal unit is constructed like this, and it is also needed to miniaturize a tuning fork, quartz crystal resonator to obtain a miniaturized quartz crystal unit with it.

It is, however, impossible to obtain a miniaturized quartz crystal unit with a conventional miniaturized, flexural mode, tuning fork, quartz crystal resonator with a small series resistance and a high quality factor. When miniaturized the conventional flexural mode, tuning fork, quartz crystal, resonator shown in FIG. 29 (which has electrodes on the obverse faces 203, 207, reverse faces 204, 208 and the four sides 205, 206, 209, 210 of each tuning fork tine, as also shown in FIG. 30—a cross-sectional view of tuning fork tines of FIG. 29), has a smaller electromechanical transformation efficiency, which provides a small electric field (i.e. Ex becomes small), a large series resistance, and a reduced quality factor. In FIG. 29, the conventional tuning fork resonator 113 is shown with tuning fork tines 114, 115 and tuning fork base 116.

In addition, it is impossible to obtain a flexural mode, tuning fork, quartz crystal resonator with a small frequency change over a wide temperature range of between  $-10^{\circ}$  C. to  $+50^{\circ}$  C. because the resonator has a temperature coefficient with a parabolic curve, and whose second order temperature coefficient is approximately  $-3.5 \times 10^{-8}/^{\circ}$  C.<sup>2</sup>. This value is comparatively large as compared with AT cut quartz crystal resonators vibrating in thickness shear mode.

Moreover, for example, Japanese Patent Nos. P56-65517 and P2000-223992A and International Patent No. WO 00/44092 teach grooves and electrodes constructed at tuning fork tines of a flexural mode, tuning fork, quartz crystal resonator. However, they teach nothing about a quartz crystal unit of the present invention having novel shape, novel electrode construction and an improvement of frequency tem-

perature behaviour for a flexural mode, tuning fork, quartz crystal resonator, and also, teach nothing about a method of manufacturing a quartz crystal unit of the present invention.

It is, therefore, an object of the present invention to provide a quartz crystal unit with a flexural mode, tuning fork, quartz crystal resonator which overcomes the above-described problems and its manufacturing method.

### SUMMARY OF THE INVENTION

The present invention relate to the shape and electrode construction of a flexural mode, tuning fork, quartz crystal resonator which is housed in a case, and in particular, a novel shape and electrode construction for a flexural mode, tuning fork, quartz crystal resonator available for consumer products and communication equipment requiring miniaturized, high accuracy, shock proof and low priced quartz crystal units.

It is an object of the present invention to provide a quartz crystal unit with a miniaturized flexural mode, tuning fork, quartz crystal resonator with a small series resistance  $R_1$  and a high quality factor Q.

It is an another object of the present invention to provide a quartz crystal unit with a flexural mode, tuning fork, quartz crystal resonator with an excellent frequency temperature behaviour over a wide temperature range (of  $-10^{\circ}$  C. to  $+50^{\circ}$  C.).

It is a further object of the present invention to provide a method of manufacturing a quartz crystal unit.

According to one aspect of the present invention there is provided a quartz crystal unit with a tuning fork, quartz crystal resonator capable of vibrating in flexural mode comprising; tuning fork tines, a tuning fork base, said tuning fork tines having step difference portions and medium surface portions, with at least one first electrode on said step difference portions, with at least one second electrode disposed on the side of said tuning fork tines, and said at least one first and at least one second electrodes being of opposite electrical polarity.

According to a second aspect of the present invention there is provided a quartz crystal unit with a tuning fork, quartz crystal resonator capable of vibrating in flexural mode comprising; tuning fork tines, and a tuning fork base, a plurality of step difference portions provided at said tuning fork tines along the direction of length thereof, at least two of the plurality of step difference portions being connected via at least one step portion, first electrodes on the step difference portions, second electrodes disposed opposite to the first electrodes on the sides of said tuning fork tines, and said first and second electrodes being of opposite electrical polarity.

According to a third aspect of the present invention, there is provided a quartz crystal unit with a tuning fork, quartz crystal resonator capable of vibrating in flexural mode comprising; tuning fork tines, and a tuning fork base, at least one groove provided in the central line portion of each of said tuning fork tines, at least one first electrode provided inside each groove, at least one second electrode provided on the sides of said tuning fork tines, and for each tine said at least one second electrode having an opposite electrical polarity to said at least one first electrode.

According to a fourth aspect of the present invention there is provided a quartz crystal unit with a quartz crystal, tuning fork, resonator capable of vibrating in flexural mode comprising; tuning fork tines, tuning fork base, a plurality of grooves provided only on the tuning fork base where said base is coupled to the tuning fork tines, and electrodes provided in said grooves.

According to a fifth aspect of the present invention there is provided a quartz crystal unit with a resonator comprising; a

3

plurality of individual flexural mode, tuning fork, quartz crystal resonators being connected and formed integrally at each tuning fork base via connecting portion wherein said individual quartz crystal resonators are coupled to each other at the respective tuning fork bases via the connecting portion and having an angle of separation of  $0^\circ$  to  $30^\circ$ .

According to a sixth aspect of the present invention there is provided a method for manufacturing a quartz crystal unit comprising: a flexural mode, tuning fork, quartz crystal resonator, a case of surface mounting type and a lid.

Embodiments of the present invention may provide a high electromechanical transformation efficiency.

Embodiments of the present invention use step differences or grooves and an electrode construction arranged on the tuning fork tines and/or tuning fork base of a flexural mode, tuning fork, quartz crystal resonator.

Preferably, the resonator has a step difference constructed at tuning fork tines and/or tuning fork base and electrodes disposed on the step difference portions.

Preferably, the resonator has grooves including the central line of the central portions for each tuning fork tine and the electrodes disposed inside the grooves and disposed on the sides of each tuning fork tine. Alternatively or additionally the grooves may be arranged on the tuning fork base and the electrodes disposed inside the grooves.

Preferably, at least two individual flexural mode, tuning fork, quartz crystal resonators connected and formed integrally at their respective tuning fork base via connecting portion may improve the frequency temperature behaviour. The quartz crystal resonators whose peak temperature points are different, may be connected electrically in parallel. As a result, the integrally formed quartz crystal resonator may have excellent frequency temperature behaviour over a wide temperature range of  $-10^\circ\text{C}$ . to  $+50^\circ\text{C}$ .

For a better understanding of the present invention, and as to how the same may be carried into effect, reference will now be made by way of example to the accompanying drawings.

#### BRIEF DESCRIPTION OF THE DRAWINGS

FIG. 1(a) and FIG. 1(b) show a plan view omitting a lid and a side view of a quartz crystal unit of the first embodiment of the present invention;

FIG. 2 is a general view of a flexural mode quartz crystal resonator of tuning fork type with grooves at each tuning fork tine constructing the quartz crystal unit of the present invention shown in FIG. 1(a) and FIG. 1(b) and its coordinate system;

FIG. 3 is a A-A' and B-B' cross-sectional views of the tuning fork tines of FIG. 2 illustrating electrode construction;

FIG. 4 is a plan view of the tuning fork, quartz crystal resonator of FIG. 2;

FIG. 5 is a general view of a flexural mode, tuning fork, quartz crystal resonator constructing a quartz crystal unit of the second embodiment of the present invention, and having plural grooves at the tuning fork base;

FIG. 6 is a D-D' cross-sectional view of the tuning fork base of FIG. 5 and illustrating electrode construction;

FIG. 7 is a plan view of the flexural mode quartz crystal resonator of FIG. 5;

FIG. 8 is a plan view of a flexural mode, tuning fork, quartz crystal resonator constructing a quartz crystal unit of the third embodiment of the present invention;

FIG. 9 is a plan view of a flexural mode, tuning fork, quartz crystal resonator constructing a quartz crystal unit of the fourth embodiment of the present invention;

4

FIG. 10 is a F-F' cross-sectional view of the tuning fork base of FIG. 9 and illustrating electrode construction;

FIG. 11 is a general view of a flexural mode, tuning fork, quartz crystal resonator constructing a quartz crystal unit of the fifth embodiment of the present invention and its coordinate system;

FIG. 12 is a plan view of the flexural mode quartz crystal resonator of FIG. 11;

FIG. 13 is a I-I' cross-sectional view of the tuning fork tines of FIG. 12 and illustrating electrode construction;

FIG. 14 is a general view of a flexural mode, tuning fork, quartz crystal resonator constructing a quartz crystal unit of the sixth embodiment: of the present invention and its coordinate system;

FIG. 15 is a plan view of the flexural mode quartz crystal resonator of FIG. 14;

FIG. 16 is a J-J' cross-sectional view of the tuning fork tines of FIG. 15 and illustrating electrode construction;

FIG. 17 is a plan view of a flexural mode quartz crystal resonator constructing a quartz crystal unit of the seventh embodiment of the present invention;

FIG. 18 is a plan view of a flexural mode quartz crystal resonator constructing a quartz crystal unit of the eighth embodiment of the present invention;

FIG. 19 is a plan view of a flexural mode quartz crystal resonator constructing a quartz crystal unit of the ninth embodiment of the present invention;

FIG. 20 is a M-M' cross-sectional view of the tuning fork tines of FIG. 19 and illustrating electrode construction;

FIG. 21 is a plan view of a flexural mode quartz crystal resonator constructing a quartz crystal unit of the tenth embodiment of the present invention;

FIG. 22 is a N-N' cross-sectional view of the tuning fork base of FIG. 21 and illustrating electrode construction;

FIG. 23 shows a plan view of a quartz crystal unit of the eleventh embodiment of the present invention and omitting a lid, which has two flexural mode, tuning fork, quartz crystal resonators with grooves connected and formed integrally at each tuning base via connecting portion and have an angle  $\phi$  of separation;

FIG. 24 shows a diagram of an electrical connection for the flexural mode quartz crystal resonators of FIG. 23;

FIG. 25 shows an example of frequency temperature behaviour of the quartz crystal unit of said eleventh embodiment;

FIG. 26 shows a plan view of a quartz crystal unit of the twelfth embodiment of the present invention and omitting a lid, which has two flexural mode, tuning fork, quartz crystal resonators connected at each tuning bases via connecting portion and a dividing portion is constructed between the resonators;

FIG. 27 shows a step diagram of a method for manufacturing a quartz crystal unit of the present invention;

FIG. 28(a) and FIG. 28(b) are a plan view and a side view of the conventional quartz crystal unit;

FIG. 29 is a general view of the conventional flexural mode, tuning fork, quartz crystal resonator constructing the quartz crystal unit of the prior art;

FIG. 30 is a cross-sectional view of the tuning fork tines of FIG. 29 and illustrating electrode construction.

#### DETAILED DESCRIPTION OF THE PREFERRED EMBODIMENTS

Referring now to the drawings, the embodiments of the present invention will be described in full detail.

## 5

FIG. 1(a) and FIG. 1(b) show a plan view omitting a lid and a side view of a quartz crystal unit of the first embodiment of the present invention. The quartz crystal unit 1 comprises a case 2, a flexural mode, tuning fork, quartz crystal resonator 3 and a lid 19. Also, the resonator 3 comprises tuning fork tines 4, 5 and tuning fork base 6, and the base 6 is fixed on a mounting portion 7 constructed at the case 2 by conductive adhesives 8, 9 or solder. Additionally, grooves 10, 11 are constructed at the tines 4, 5 and the grooves extend into the base 6 in this embodiment. A flexural mode, tuning fork, quartz crystal resonator which is housed in a case of a quartz crystal unit of the present invention will be described in FIG. 2-FIG. 23 in detail.

Also, electrodes 12, 13 are disposed on the mounting portion 7 and connected to the respective electrodes with opposite electrical polarity disposed on the base 6, as a result of which two electrode terminals are constructed. In full detail, the electrode 12 extends into the reverse face of the case 2 and are connected to an electrode 14 constructed at one end portion thereof, while the electrode 13 also extends into the reverse face of the case 2 and connected to an electrode 15 constructed at other end portion thereof. The case 2 and lid 19 are connected via connecting member 16.

In this embodiment, though the electrodes 14 and 15 are constructed at both ends of the reverse face of the case 2, they may be constructed at an arbitrary location thereof. This electrode construction is also applied to embodiments which are described as follows.

In addition, the case 2 in this embodiment has a hole 17 to close it in vacuum and the hole 17 is closed by closing member 18. Also, ceramics or glass as a material of the case, glass or metal as a material of the lid, glass with the low melting point or metal including solder as a connecting member to connect the case and the lid and similarly, the glass with the low melting point or the metal as a closing member to close the hole are used respectively.

In this embodiment, though the case 2 has the hole 17 to close it in vacuum, the case 2 with no hole and the lid may be directly closed in vacuum via the connecting member. The construction of the case and the lid in this embodiment is also applied to that in another embodiments which are described as follows.

FIG. 2 shows a general view of a flexural mode, tuning fork, quartz crystal resonator housed in the case 2 of FIG. 1(a) and FIG. 1(b) embodying the present invention and its coordinate system. The coordinate system consists of an origin O, an electrical axis x, a mechanical axis y and an optical axis z of quartz, namely, O-xyz. A flexural mode, tuning fork, quartz crystal resonator 21 embodying the present invention comprises a first tuning fork tine 22, a second tuning fork tine 23 and a tuning fork base 24, the first tuning fork tine 22 and the second tuning fork tine 23 are connected at the tuning fork base 24. In addition, grooves 25 and 31 each of which has a plurality of step difference portions, i.e., stepped portions including a first stepped portion, a second stepped portion and a third stepped portion connecting the first stepped portion to the second stepped portion as is shown in FIG. 3 and FIG. 4, are constructed within the obverse [face] faces of tuning fork tines 22 and 23 which include a portion of the central line, respectively, as shown in [FIG. 3,] FIG. 4, and the same grooves are constructed within the reverse [face] faces of the tines 22 and 23. A cut angle  $\theta$ , which has a typical value of  $0^\circ$  to  $10^\circ$ , is rotated from a Z-plate perpendicular to z axis about the x axis. Additionally, a groove is constructed at least with two step difference portions along the direction of length of tuning fork tines. In this embodiment, the groove is con-

## 6

structed with four step difference portions and has a rectangular shape in the plan view of FIG. 1.

FIG. 3 shows the A-A' and B-B' cross-sectional views of the tuning fork tines of FIG. 2 and electrode construction within the grooves. The A-A' cross-sectional view of the tuning fork tine 22 is shown on the right side and the B-B' cross-sectional view of the tuning fork tine 23 is shown on the left side. The tuning fork tine 22 has a first side surface and a second side surface opposite the first side surface and grooves 25 and 26 each of which has a first stepped portion opposite the first side surface and a second stepped portion opposite the second side surface or a first surface opposite the first side surface and a second surface opposite the second side surface, cut into it, which include a portion of central line of the tine 22. The grooves 25 and 26 have a first set of electrodes 27 and 28 of the same electrical polarity, while the [sides] first and second side surfaces of the tine 22 have a second set of electrodes 29 and 30 having an opposite electrical polarity to the first set of electrodes 27 and 28. The tuning fork tine 23 has a first side surface and a second side surface opposite the first side surface and grooves 31 and 32 each of which has a first stepped portion opposite the first side surface and a second stepped portion opposite the second side surface or a first surface opposite the first side surface and a second surface opposite the second side surface, constructed in a similar manner as tuning fork tine 22. The grooves 31 and 32 have a third set of electrodes 33 and 34 of the same electrical polarity, and the [sides] first and second side surfaces of the tine 23 have a fourth set of electrodes 35 and 36 with the opposite electrical polarity to the third electrodes 33 and 34. The electrodes disposed on the tuning fork tines 22 and 23 are connected as shown in FIG. 3, namely, two electrode terminals of different polarity C-C' are obtained.

In detail, the first set of electrodes 27 and 28 disposed on surfaces of the grooves 25 and 26 of the tuning fork tine 22 have the same electrical polarity as the fourth set of electrodes 35 and 36 disposed on [both sides] the first and second side surfaces of the tuning fork tine 23, while the second set of electrodes 29 and 30 disposed on [both sides] the first and second side surfaces of the tuning fork tine 22 have the same electrical polarity as the third set of electrodes 33 and 34 disposed on the grooves 31 and 32 of the tine 23. Now, when a direct voltage is applied between the electrode terminals C-C', an electric field  $E_x$  occurs along the arrow direction inside the tuning fork tines 22 and 23. As the electric field  $E_x$  occurs perpendicular to the electrodes disposed on the tuning fork tines, as shown in the arrow signs, the electric field  $E_x$  has a very large value and a large distortion occurs at the tuning fork tines. As a result, a tuning fork, quartz crystal resonator is obtained with a small series resistance  $R_1$  and a high quality factor Q because even when miniaturized there is a large electromechanical transformation efficiency for the resonator. Thus, each of the tuning fork tines 22, 23 has a first main surface and a second main surface opposite the first main surface, and a first side surface and a second side surface opposite the first side surface, and the grooves 25, 26 are formed in the first and second main surfaces of the tuning fork tine 22 and the grooves 31, 32 are formed in the first and second main surfaces of the tuning fork tine 23. In addition, a first electrode is disposed on a surface of each of the grooves 25, 26, 31 and 32 formed in the first and second main surfaces of each of the tuning fork tines 22, 23 and a second electrode is disposed on each of the first and second side surfaces of each of the tuning fork tines 22, 23 so that the first electrodes 27, 28 disposed on the surfaces of the grooves 25, 26 formed in the first and second main surfaces of the tuning fork tine 22 are connected to the second electrodes 35, 36 disposed on the

first and second side surfaces of the tuning fork tine 23, and the first electrodes 33, 34 disposed on the surfaces of the grooves 31, 32 formed in the first and second main surfaces of the tuning fork tine 23 are connected to the second electrodes 29, 30 disposed on the first and second side surfaces of the tuning fork tine 22.

FIG. 4 shows a plan view of [a] the tuning fork, quartz crystal resonator 21 of FIG. 2. In FIG. 4, the construction and the dimension of grooves 25 and 31 are described in detail. The groove 25 is constructed to include a portion of the central line 37 of the tuning fork tine 22, the groove 31 is similarly constructed to include a portion of the central line 38 of the tuning fork tine 23. The width  $W_2$  of the grooves 25 and 31 which include a portion of the central lines 37 and 38, respectively, is preferable because the tuning fork tines 22 and 23 can vibrate in a flexural mode easily.

In other words, [a] the flexural mode, tuning fork, quartz crystal resonator can be obtained with a small series resistance  $R_1$  and a high quality factor  $Q$ . The total width  $W$  of the tuning fork tines 22 and 23 has a relationship of  $W=W_1+W_2+W_3$ , and in general at least one of the four grooves 25, 26, 31 and 32 is constructed so that  $W_1 \cong W_3$ . Namely, each of the four grooves 25, 26, 31 and 32 has the first stepped portion opposite the first side surface of the tuning fork tine and the second stepped portion opposite the second side surface of the tuning fork tine as described in FIG. 3, and when a distance in the width direction of the groove measured from a first outer edge of the groove to a first outer edge of the corresponding one of the quartz crystal tuning fork tines 22, 23 is defined by  $W_1$  and a distance in the width direction of the groove measured from a second outer edge of the groove to a second outer edge of the corresponding one of the quartz crystal tuning fork tines 22, 23 is defined by  $W_3$ , the groove is formed in at least one of the first and second main surfaces of each of the tuning fork tines 22, 23 so that  $W_1$  is greater than  $W_3$ . In addition, the width  $W_2$  of the grooves is constructed so that  $W_2 \cong W_1, W_3$ . Also, a ratio ( $W_2/W$ ) of the groove width  $W_2$  and the total width  $W$  is in a range of 0.35 to 0.85 because a moment of inertia of each of the tuning fork tines becomes very large by the ratio. That is to say, [a] the flexural mode, tuning fork, quartz crystal resonator can be provided with a small series resistance  $R_1$ , a quality factor  $Q$  and a small capacitance ratio because electromechanical transformation efficiency becomes large markedly.

Likewise, the length  $l_1$  of the grooves 25 and 31 of tuning fork tines 22 and 23 extends into the tuning fork base 24 (which has a dimension of the length  $l_2$  and the length  $l_3$  of the grooves). Furthermore, the total length  $l$  is determined by the frequency requirement and the size of the housing case. At the same time, to get a flexural mode, tuning fork, quartz crystal resonator capable of vibrating easily in fundamental mode with suppression of the second and third overtone modes which are unwanted vibration modes, there is a close relationship between groove length  $l_1$  and the total length  $l$ . Namely, a ratio ( $l_1/l$ ) of the groove length  $l_1$  and the total length  $l$  is in a range of 0.2 to 0.78 because the quantity of charges which generate within the grooves and on the sides of the tuning fork tines and/or the tuning fork base can be controlled by the ratio and the second and third overtone modes which are unwanted vibration modes can be suppressed substantially. In order to achieve the above mentioned object, it may be satisfied with at least one groove with the ratio constructed at the tines. As a result of which the flexural mode, tuning fork, quartz crystal resonator capable of vibrating easily in fundamental mode can be realized.

In more detail, series resistance  $R_1$  of the quartz crystal resonator capable of vibrating in fundamental mode becomes

smaller than series resistances  $R_2$  and  $R_3$  of the second and third overtone modes. Namely,  $R_1 < R_2, R_3$ , therefore, an oscillator comprising an amplifier (CMOS inverter), capacitors, resistors (resistance elements) and a quartz crystal unit with the tuning fork quartz crystal resonator of this embodiment can be obtained, which is capable of vibrating in fundamental mode very easily. In addition, in this embodiment the grooves 25 and 31 of tuning fork tines 22 and 23 extend into the tuning fork base 24 in series, but embodiment of the present invention includes a plurality of grooves divided in the length direction of the tuning fork tines.

In summary the embodiments shown within FIG. 1 to FIG. 4, the tuning fork tines have four grooves within the obverse and the reverse faces thereof and electrodes provided inside the grooves as well as electrodes disposed on both sides of the tuning fork tines. The embodiments of the present invention, however, may have at least one groove within at least at one surface of the tuning fork tines and an electrode inside the at least one groove as well as electrodes disposed on both sides of the tuning fork tine. Also, it is provided that the first electrode inside the groove and the second electrodes on said side of the tine next to said electrode are of opposite electrical polarity.

In addition, though the electrodes are disposed within the grooves and on the side faces of the tuning fork base in this embodiment, the present invention is not limited to this, but includes at least one electrode which is of opposite electrical polarity to the electrodes of adjoining grooves between the grooves of the tuning fork base, disposed on each of the obverse and reverse faces thereof. For example, two electrodes 25a and 31a illustrated by virtual lines in FIG. 4, or four electrodes where the electrodes disposed opposite each other in the thickness direction are of the same electrical polarity.

FIG. 5 shows a general view of a flexural mode, tuning fork, quartz crystal resonator 69 which constructs a quartz crystal unit of the second embodiment of the present invention and its coordinate system O-xyz. A cut angle  $\theta$ , which has a typical value of  $0^\circ$  to  $10^\circ$ , is rotated from a Z-plate perpendicular to the z axis about the x axis. The flexural mode, tuning fork, quartz crystal resonator 69 comprises two tuning fork tines 70 and 76 and tuning fork base 90. The tuning fork tines 70 and 76 have grooves 71 and 77 respectively, with the grooves 71 and 77 extending into the tuning fork base 90. In addition, the tuning fork base 90 has the additional grooves 82 and 86.

FIG. 6 shows a D-D' cross-sectional view of the tuning fork base 90 for the flexural mode, tuning fork, quartz crystal resonator 69 of FIG. 5. In FIG. 6, the shape of the electrode construction within the tuning fork base 90 for the quartz crystal resonator of FIG. 5 is described in detail. The section of the tuning fork base 90 which couples to the tuning fork tine 70 has the grooves 71 and 72 cut into the obverse and the reverse faces of the base 90. Also, the section of the tuning fork base 90 which couples to the tuning fork tine 76 has the grooves 77 and 78 cut into the obverse and the reverse faces of the base 90. In addition to these grooves, the tuning fork base 90 has the grooves 82 and 86 cut between the grooves 71 and 77, and also, the base 90 has the grooves 83 and 87 cut between the grooves 72 and 78.

Furthermore, the grooves 71 and 72 have the first electrodes 73 and 74 both of the same electrical polarity, the grooves 82 and 83 have the second electrodes 84 and 85 both of the same electrical polarity, the grooves 86 and 87 have the third electrodes 88 and 89 both of the same electrical polarity, the grooves 77 and 78 have the fourth electrodes 79 and 80 both of same electrical polarity and the sides of the base 90 have the fifth and sixth electrodes 75 and 81, each of opposite

electrical polarity. In more detail, the fifth, fourth, and second electrodes **75**, **79**, **80**, **84** and **85** have the same electrical polarity, while the first, sixth and third electrodes **73**, **74**, **81**, **88** and **89** have the opposite electrical polarity to the others. Two electrode terminals E-E' are constructed. That is, the electrodes disposed inside the grooves constructed opposite each other in the thickness (z axis) direction have the same electrical polarity. Also, the electrodes disposed opposite each other across adjoining grooves have opposite electrical polarity.

Now, when a direct voltage is applied between the electrode terminals E-E' (E terminal: plus, E' terminal: minus), an electric field  $E_x$  occurs in the arrow direction as shown in FIG. 6. As the electric field  $E_x$  occurs perpendicular to the electrodes disposed on the tuning fork base, the electric field  $E_x$  has a very large value and a large distortion occurs at the tuning fork base, so that a flexural mode, tuning fork, quartz crystal resonator is obtained with a small series resistance  $R_1$  and a high quality factor Q, even if it is miniaturized.

FIG. 7 shows a plan view of the tuning fork, quartz crystal resonator **69** of FIG. 5. In FIG. 7, the disposition of the grooves **71** and **77** is particularly described in detail. The tuning fork tine **70** has the groove **71** cut including a portion of the central line **91** of the tine, as well, the tuning fork tine **76** has also the groove **77** cut including a portion of the central line **92** of the tine. In addition, a flexural mode, tuning fork, quartz crystal resonator embodying the present invention has grooves **82** and **86** between the grooves **71** and **77** constructed at the tuning fork base **90** and the tuning fork tines **70** and **76**.

Thus, a flexural mode, tuning fork, quartz crystal resonator with the shape and the electrode construction embodying the present invention has excellent electrical characteristics, even if it is miniaturized. Namely, the quartz crystal resonator has a small series resistance  $R_1$  and a high quality factor Q. The width dimension  $W=W_1+W_2+W_3$ , and length dimensions  $l_1$ ,  $l_2$  and  $l_3$  are as already described in relation to FIG. 4.

FIG. 8 shows a plan view of a flexural mode, tuning fork, quartz crystal resonator **145** which constructs a quartz crystal unit of the third embodiment of the present invention. The flexural mode, tuning fork, quartz crystal resonator **145** comprises tuning fork tines **146**, **147** and tuning fork base **148**. At least one end of the tuning fork tines **146** and **147** connected to the tuning fork base **148**. In this embodiment, a plurality of grooves **149**, **150**, **151** and **152** are constructed only within the tuning fork base **148**. Additionally, a plurality of grooves is similarly constructed within the reverse face of tuning fork base **148**.

In addition, the grooves **149** and **150** are constructed within the tuning fork base **148** where at least one end of the tuning fork tines **146** and **147** is connected to the tuning fork base **148**. Furthermore, the grooves **151** and **152** are constructed between the grooves **149** and **150**. The electrode disposition and the construction is not shown, but is similar to that already explained in detail in FIG. 6. Thus, by constructing the grooves and the electrodes, a flexural mode, tuning fork, quartz crystal resonator is obtained with a small series resistance  $R_1$  and a high quality factor Q because a large distortion occurs at the tuning fork base.

FIG. 9 shows a plan view of a flexural mode, tuning fork, quartz crystal resonator **153** which constructs a quartz crystal unit of the fourth embodiment of the present invention. The quartz crystal resonator of tuning fork type **153** comprises the tuning fork tines **154**, **155** and the tuning fork base **156**. The tuning fork tines **154** and **155** have grooves **157** and **158** which extend to the tuning fork base **156**. In addition, a groove **159** constructed between the grooves **157** and **158** and constructed within the tuning fork base **156**.

FIG. 10 shows F-F' cross-sectional view of the tuning fork base **156** for the flexural mode quartz crystal resonator **153** of FIG. 9. Here, the shape and the electrode construction of the cross-sectional view of the tuning fork base **156** for the quartz crystal resonator **153** in FIG. 9 are described in detail. As shown in FIG. 10, the quartz crystal resonator **153** has grooves **157** and **160** within the obverse and the reverse faces of the tuning fork base **156** where it connects to the tuning fork tine **154**. The groove **157** is constructed opposite the groove **160**. Similarly, the resonator **153** has grooves **158** and **161** within the obverse and the reverse faces of the tuning fork base **156** where it connects to the tuning fork tine **155**. The groove **158** is constructed opposite groove **161**. In addition, the groove **159** is constructed between the groove **157** and the groove **158**, and the groove **162** constructed opposite groove **159** is constructed between the groove **160** and groove **161**.

Furthermore, the grooves **157**, **160** have the electrodes **163**, **164** of the same electrical polarity, the grooves **159**, **162** have the electrodes **165**, **166** and the electrodes **167**, **168**, the grooves **158**, **161** have the electrodes **169**, **170** of the same electrical polarity, and both sides of the tuning fork base **156** have the electrodes **171**, **172** of opposite electrical polarities. The electrodes are connected in such a way that electrodes disposed opposite the sides of the grooves **157**, **158**, **159**, **160**, **161**, **162** have different electrical polarities. Thus, the electrodes **165**, **167**, **169**, **170**, **171** are all the same electrical polarity while the electrodes **163**, **164**, **166**, **168**, **172** are the opposite electrical polarity. As a result, the embodiment of the present resonator has two electrode terminals G-G'.

Therefore, the groove **159** has the electrode **165** and the electrode **166** each of opposite electrical polarity, similarly, the groove **162** has the electrode **167** and the electrode **168** each of opposite electrical polarity. The electrodes disposed opposite the electrodes disposed on the sides of the adjoining grooves in the x-axis direction are of opposite electrical polarity. That is, in this embodiment, the electrode **173** disposed on the side of the grooves **157** opposite to the electrode **165** disposed on the side of the groove **159** are of opposite electrical polarities, similarly, the electrodes **175** and **167** are of opposite electrical polarities, the electrodes **166** and **174** are also of opposite electrical polarities, and the electrodes **168** and **176** are of opposite electrical polarities. In addition, the electrode **163** and the electrode **164** disposed inside the grooves **157** and **160** constructed opposite in the thickness (z-axis) direction are the same electrical polarity. Likewise, the electrode **169** and the electrode **170** disposed inside the grooves **158** and **161** constructed opposite in the thickness (z-axis) direction are also the same electrical polarity. The electrodes **163**, **164**, **169**, **170** disposed inside the grooves **157**, **160**, **158**, **161** and the electrodes **171**, **172** disposed on the sides of the tuning fork base **156** extend from the tuning fork base **156** to the tuning fork tines **154**, **155**.

Now, when an alternating voltage is applied between two electrode terminals G-G', an electric field  $E_x$  occurs alternately along the arrow directions shown by the solid and broken lines. As a result, a flexural mode is generated in the inverse phase. In addition, as the electric field  $E_x$  occurs perpendicular to the electrodes between the electrodes disposed on the sides of the grooves, the electric field  $E_x$  becomes large, and as the tuning fork base **156** also has grooves **159**, **162** and electrodes **165**, **166**, **167**, **168**, a markedly large distortion occurs at the tuning fork base, so that a flexural mode, tuning fork, quartz crystal resonator is obtained with a small series resistance  $R_1$  and a high quality factor Q when it is miniaturized. In the above-mentioned embodiments the grooves are constructed on the tuning fork tines and/or the tuning fork base, but embodiment of the



## 11

present invention includes holes instead of the grooves or a combination of the grooves and the holes. In addition, two electrode terminals implies two electrodes which are of opposite electrical polarity and also includes electrodes divided into more than three two of which are of opposite electrical polarity.

FIG. 11 shows a general view of a flexural mode, tuning fork, quartz crystal resonator 300 which constructs a quartz crystal unit of the fifth embodiment of the present invention and its coordinate system. FIG. 12 is a plan view of the resonator 300 shown in FIG. 11, and FIG. 13 shows a I-I' cross-sectional view of tuning fork tines shown in FIG. 12. As shown in FIG. 11, the resonator 300 is formed from a quartz crystal wafer rotated about x-axis and with a cut angle  $\theta$ . In general, a cut angle  $\theta$  has a value of  $0^\circ$  to  $10^\circ$ . Here,  $y'$  and  $z'$  axes are the new y and z axes obtained after the rotation about the x-axis. This flexural mode, tuning fork, quartz crystal resonator 300 comprises tuning fork tines 301, 302 and tuning fork base 303, and has thickness t. In addition, the tuning fork tine 301 has step difference portions, and the step difference portion 304 (the inner side of upper surface portion 301a) is formed between upper surface portion 301a and medium surface portion 301b. The medium surface portion 301b and the step difference portion 304 extend to the tuning fork base 303.

Also, similar to the tuning fork tine 301, the medium surface portion 302b and the step difference portion 305 are formed on the obverse face of the tuning fork tine 302, as shown in FIG. 12 and FIG. 13, furthermore, the upper surface portion 303a, the medium surface portion 303b and the step difference portion 306 are formed on the tuning fork base 303. Namely, as shown in FIG. 12, the tuning fork tine 301 of this resonator 300 has the step difference portion 304, while the tuning fork tine 302 has the step difference portion 305, these step difference portions extend to the tuning fork base 303, and the step difference portions 304 and 305 are connected at the step difference portion 306 of the tuning fork base 303. In this embodiment the step difference portions of tuning fork tines are constructed in series, but embodiment of the present invention includes a plurality of step difference portions divided in the length direction of the tuning fork tines.

In addition, as shown in FIG. 13, a structure similar to the obverse face of the tuning fork tine 301, is also constructed on the reverse face. The step difference portion 307 is formed between the lower surface portion 301c and the medium surface portion 301d and the step difference portion 307 extend to the tuning fork base 303. Here, the step difference portion 304 of the obverse face turns toward the inside of the tuning fork tine 301 and the step difference portion 307 of the reverse face turns toward the outside of the tuning fork tine 301. The electrode 308 is disposed on the step difference portion 304 and the electrode 309, which is connected to the electrode 308, is disposed on the medium surface portion 301b. The electrode 310 is disposed on the step difference portion 307 and the electrode 311, which is connected to the electrode 310, is disposed on the medium surface portion 301d. In addition, the electrode 312 is disposed on the side of the tine 301 opposite the electrode 308 disposed on the step difference portion 304 and the electrode 313 is disposed on the side of the tine 301 opposite the electrode 310 disposed on the step difference portion 307.

Thus, by this arrangement of electrodes, an electric field  $E_x$  occurs perpendicularly between the electrodes 308 and 312 and the electrodes 310 and 313. Similarly, the tuning fork tine 302 also has the step difference and the electrodes of left and right symmetry to the tuning fork tine 301. Namely, the step difference portions 305, 314, the upper surface portion 302a,

## 12

the medium surface portion 302b and the medium surface portion 302d are constructed on the obverse and the reverse faces of the tuning fork tine 302. The electrode 315 is disposed on the step difference portion 305 and the electrode 316, which is connected to the electrode 315, is disposed on the medium surface portion 302b, and also the electrode 317 is disposed on the step difference portion 314 and electrode 318, which is connected to the electrode 317, is disposed on the medium surface portion 302d. In addition, the electrode 319 is disposed on the side of the tine 302 opposite the electrode 315 and the electrode 320 is disposed on the side of the tine 302 opposite the electrode 317. In more detail, the first set of electrodes 308, 309, 310, 311, 319 and 320 are the same electrical polarity and the second set of electrodes 312, 313, 315, 316, 317 and 318 are the opposite electrical polarity to the first set of electrodes. As a result, two electrode terminals K-K' are constructed.

Now, when an alternating voltage is applied between the electrode terminals K-K', an electric field  $E_x$  occurs perpendicularly and alternately between the electrodes, as shown by the solid and broken arrow signs in FIG. 13 and a flexural mode vibration can be easily excited, so that a flexural mode, tuning fork, quartz crystal resonator is obtained with a small series resistance RI and a high quality factor Q because the electromechanical transformation efficiency for the resonator becomes large.

FIG. 14 shows a general view of a flexural mode, tuning fork, quartz crystal resonator 321 which constructs a quartz crystal unit of the sixth embodiment of the present invention and its coordinate system. FIG. 15 is a plan view of the resonator 321 of FIG. 14, and FIG. 16 shows a J-J' cross-sectional view of tuning fork tines of FIG. 15. Here, the coordinate system in this embodiment is the same as that shown in FIG. 11. A flexural mode, tuning fork, quartz crystal resonator 321 comprises the tuning fork tines 322, 323 and the tuning fork base 324, and has a thickness t. In addition, the tuning fork tine 322 has the step difference, as shown in FIG. 14 and FIG. 16. The upper surface portion 322a, the medium surface portions 322b, 322d, the step difference portions 325, 328 and the lower surface portion 322c are formed on the tuning fork tine 322. The medium surface portions 322b, 322d, and the step difference portions 325, 328 extend to the tuning fork base 324 whose obverse face is shaped to the upper surface portion 324a, the medium surface portion 324b and the step difference portion 327 and whose reverse face has the same shape as the obverse face (though the shape is not shown in the FIGS. 14 and 15).

In the same way, the upper surface portion 323a, the medium surface portions 323b, 323d, the step difference portions 326, 329 and the lower surface portion 323c are formed on the tuning fork tine 323. The medium surface portions 323b, 323d and the step difference portions 326, 329 extend to the tuning fork base 324 in a manner similar to said tuning fork tine 322. In other words, as shown in FIGS. 15 and 16, the tuning fork tines 322 and 323 have the step difference portions 325 and 326 which extend to the tuning fork base 324 and connect at the step difference portion 327. In addition, the step difference portions 325 and 328 are constructed at the obverse and the reverse faces of the tuning fork tine 322 and also the step difference portions 326 and 329 are constructed on the obverse and the reverse faces of the tuning fork tine 323. In this embodiment, the step difference portions 325, 328 and 326, 329 turn to the inside of the tuning fork tines 322 and 323, the same effect is obtained when said step difference portions 325, 328 and 326, 329 turn to outside of said tines 322 and 323, as shown in FIGS. 17, 18, 19 and 21.

Furthermore, the electrode 330 is disposed on the step difference portion 325 and electrode 331, which is connected to the electrode 330, is disposed on the medium surface portion 322b, electrode 332 is also disposed on the step difference portion 328 and electrode 333, which is connected to the electrode 332, is disposed on the medium surface portion 322d, and electrodes 334, 335 are disposed on both sides of the tuning fork tine 322. Namely, electrode 335 is disposed opposite electrodes 330 and 332 which are of opposite electrical polarity from said electrode 335. Similar to said tuning fork tine 322, the tuning fork tine 323 also has the step difference and electrodes of left and right symmetry to said tuning fork tine 322.

That is to say, the tuning fork tine 323 has the step difference portions 326, 329, the upper surface portion 323a, the medium surface portions 323b, 323d and the lower surface portion 323c, and the step difference portion 326 has electrode 336, which is connected to electrode 337, disposed on the medium surface portion 323b, while the step difference portion 329 has electrode 338, which is connected to electrode 339, disposed on the medium surface portion 323d, and electrodes 340, 341 are disposed on both sides of the tuning fork tine 323. Namely, electrode 341 is disposed in opposition to electrodes 336 and 338 which are of opposite electrical polarity from said electrode 341. In full detail, as shown in FIG. 16, the first set of electrodes 330, 331, 332, 333, 340 and 341 have the same electrical polarity, while the second set of electrodes 334, 335, 336, 337, 338 and 339 are of opposite electrical polarity to the first set of electrodes. Two electrode terminals L-L' are able to be constructed.

When an alternating voltage is applied between the two electrode terminals L-L', an electric field  $E_x$  occurs perpendicular to and alternately between the electrodes, as shown by the solid and broken arrow signs in FIG. 16 and a flexural mode vibration may be easily excited, so that a flexural mode, tuning fork, quartz crystal resonator is obtained with a small series resistance  $R_1$  and a high quality factor  $Q$  because the electromechanical transformation efficiency for the resonator becomes large. In this embodiment, the tuning fork tines 322 and 323 have the medium surface portions 322b, 322d, 323b and 323d on the inside of the said tines, but, the same effect as that of said shape can be obtained when the medium surface portions are constructed on the outside of the tuning fork tines 322 and 323, as shown in FIGS. 17, 18, 19 and 20.

FIG. 17 shows a plan view of a flexural mode quartz crystal resonator 351 which constructs a quartz crystal unit of the seventh embodiment of the present invention. The resonator 351 comprises tuning fork tines 352, 353 and tuning fork base 354. The tines 352 and 353 have step difference portions 355, 356 and medium surface portions 355b, 356b respectively. In this embodiment, the step difference portions 355, 356 and the medium surface portions 355b, 356b extend into the tuning fork base 354. Thus, the step difference portions turn to outside of said tines, and the medium surface portions are constructed on the outside of said tines. In addition, electrode construction of the tuning fork tines is not shown in FIG. 17, but it is performed similar to that of FIG. 16. This resonator also has the same effect as that of FIG. 14.

FIG. 18 shows a plan view of a flexural mode quartz crystal resonator 351a which constructs a quartz crystal unit of the eighth embodiment of the present invention. The resonator 351a comprises tuning fork tines 352a, 353a and tuning fork base 354a. The tines 352a and 353a have step difference portions 355a, 356a along the direction of length thereof and medium surface portions 355b, 356b respectively. In addition, the step difference portions 355a and 356a have the respective step portions 355e and 356e versus the direction of

length of the tines 352a and 353a. Namely, In this embodiment, two step difference portions are constructed at each tine and the two step difference portions are connected via a step portion. In more detail, two step difference portions which are connected via a step portion may be constructed on at least one face of obverse and reverse faces of tuning fork tines. In this embodiment, the step difference portions 355a, 356a and the medium surface portions 355b, 356b extend into the tuning fork base 354a. Electrodes for this resonator are not disposed in FIG. 18, but they are disposed on the step difference portions, the medium surface portions and side faces of the tuning fork tines similar to that of FIG. 16. Thus, by constructing the electrodes and the step difference portions connected via the step portion, a tuning fork, quartz crystal resonator capable of vibrating in fundamental mode very easily can be obtained with a small series resistance  $R_1$  and a high quality factor  $Q$  because the quantity of charges which generate on the step difference portions and the side faces of the tuning fork tines can be controlled and the second and third overtone modes for the resonator which are unwanted vibration modes can be substantially suppressed in vibration.

In this embodiment, each tuning fork tine has two step difference portions on the obverse face along the direction of length thereof which are connected via a step portion, but this invention is not limited to this. That is to say, the present invention also includes a flexural mode, tuning fork, quartz crystal resonator comprising tuning fork tines and a tuning fork base that are formed integrally, a plurality of step difference portions constructed at said tuning fork tines along the direction of length thereof, and at least two of the plurality of step difference portions being connected via at least one step portion, in other words, the at least two step difference portions are connected via at least one step portion. In more detail, a plurality of step difference portions which are connected via at least one step portion may be constructed on at least one face of obverse and reverse faces of tuning fork tines.

It is needless to say that this concept can be also applied to the flexural mode, tuning fork, quartz crystal resonators shown in FIGS. 1(a), 1(b), 5, 7 and 9, and also applied to tuning fork quartz crystal resonators which will be shown in FIGS. 19 and 21. For example, the present invention also includes a flexural mode, tuning fork, quartz crystal resonator comprising tuning fork tines *each having a first side surface and a second side surface opposite the first side surface* and a tuning fork base that are formed integrally, *and a groove [constructed, respectively, on] formed in each of obverse and reverse faces (first and second main surfaces) of each tuning fork tine. Namely, as an example of the respective grooves, the groove [constructed on] formed in the obverse face of each of the tuning fork tines has at least two step difference [portions] portions, i.e. at least two stepped portions including a first stepped portion and a second stepped portion connected to the first stepped portion along the length direction of each of the tuning fork [tine] tines, as shown in FIG. 18, and the first stepped portion is connected to the second stepped portion through a third stepped portion so that each of the first and second stepped portions of the groove formed in the obverse face of each of the tuning fork tines is formed opposite the first side surface of the corresponding one of the tuning fork tines and is directly connected to the third stepped portion, while [and] the groove [constructed on] formed in the reverse face of each of the tuning fork tines has at least three step difference [portions] portions, i.e. at least three stepped portions including first, second and third stepped portions along the length direction of each of the tuning fork [tine.] tines, and at least two of the at least three [step difference]*

stepped portions are connected via at least one [step] stepped portion. Namely, an example of this relation shows that the first stepped portion is connected to the second stepped portion through a stepped portion so that each of the first and second stepped portions of the groove formed in the reverse face of each of the tuning fork tines is formed opposite the first side surface of the corresponding one of the tuning fork tines and is directly connected to the stepped portion. In addition, the groove formed in the obverse face of each of the tuning fork tines has a fourth stepped portion directly opposite a fifth stepped portion in the length direction, the fourth stepped portion is directly connected to the first stepped portion and the fifth stepped portion is directly connected to the second stepped portion, as shown in FIG. 18. Similar to this, the groove formed in the reverse face of each of the tuning fork tines has a fourth stepped portion directly opposite a fifth stepped portion in the length direction, the fourth stepped portion is directly connected to the first stepped portion and the fifth stepped portion is directly connected to the second stepped portion. In other words, the groove formed in each of the obverse and the reverse faces of each of the tuning fork tines has a first surface and a second surface connected to the first surface through a third surface, and a fourth surface directly opposite a fifth surface in the length direction, each of the first, second and third surfaces has a first end portion and a second end portion, and also, the groove is formed in each of the obverse and the reverse faces of each of the tuning fork tines so that each of the first and second surfaces of the groove formed in each of the obverse and the reverse faces of each of the tuning fork tines is formed opposite the first side surface of the corresponding one of the tuning fork tines, and the first end portion of the first surface is directly connected to the first end portion of the third surface and the first end portion of the second surface is directly connected to the second end portion of the third surface, and so that an end portion of the fourth surface is directly connected to the second end portion of the first surface and an end portion of the fifth surface is directly connected to the second end portion of the second surface. In addition, as shown in FIG. 18, the groove formed in at least one of the obverse and reverse faces of each of the tuning fork tines comprises a first groove portion having a first width and a second groove portion having a second width different from the first width so that a first distance in the width direction of the first groove portion measured from a first outer edge of the first groove portion to a first outer edge of the first side surface of the corresponding one of the tuning fork tines is greater than a second distance in the width direction of the second groove portion measured from a second outer edge of the second groove portion to a second outer edge of the first side surface of the corresponding one of the tuning fork tines, and so that the first width of the first groove portion is greater than the first distance in the width direction of the first groove portion. For two tuning fork tines, each tine has at least two and at least three [step difference] stepped portions at obverse and reverse faces and the at least three [step difference] stepped portions at least two of which are connected via at least one [step] stepped portion, are [constructed] formed at a [different] tuning fork tine. Similarly, for more than three tines, at least three [step difference] stepped portions are [constructed] formed at [a different] each tuning fork tine. This resonator also has the same effect as that of FIG. 18.

FIG. 19 shows a plan view of a flexural mode quartz crystal resonator 357 which constructs a quartz crystal unit of the ninth embodiment of the present invention. The resonator 357 comprises tuning fork tines 358, 359 and tuning fork base 360. The tines 358 and 359 have step difference portions 361, 362 along the direction of length thereof and medium surface

portions 361b, 362b respectively, with the step difference portions 361 and 362 extending into the base 360. In addition, the base 360 has the grooves 363 and 364 between the step difference portions 361 and 362.

FIG. 20 shows a M-M' cross-sectional view of the tuning fork base 360 for the flexural mode, tuning fork, quartz crystal resonator 357 of FIG. 19. In FIG. 20, the shape of the electrode construction within the tuning fork base 360 for the quartz crystal resonator of FIG. 19 is described in detail. The section of the tuning fork base 360 which couples to the tuning fork tine 358 has the step difference portions 361, 365 and the medium surface portions 361b, 365d cut into the obverse and the reverse faces of the base 360. Also, the section of the tuning fork base 360 which couples to the tuning fork tine 359 has the step difference portions 362, 366 and the medium surface portions 362b, 366d cut into the obverse and the reverse faces of the base 360. In addition to these step difference portions, the tuning fork base 360 has the grooves 363 and 364 cut between the step difference portions 361 and 362, and also, the base 360 has the grooves 367 and 368 cut between the step difference portions 365 and 366.

Furthermore, the step difference portions 361 and 365 have the first electrodes 373 and 375 which are connected to electrodes disposed on the medium surface portions 361b and 365d, both of which have the same electrical polarity, the grooves 363 and 367 have the second electrodes 369 and 371 both of the same electrical polarity, the grooves 364 and 368 have the third electrodes 370 and 372 both of the same electrical polarity, the step difference portions 362 and 366 have the fourth electrodes 374 and 376 which are connected to electrodes disposed on the medium surface portions 362b and 366d, both of which have same electrical polarity and the sides of the base 360 have the fifth and sixth electrodes 377 and 378 which extend into the sides of the tines 358 and 359 respectively, each of which has opposite electrical polarity. In more detail, the first, third, and sixth electrodes 373, 375, 370, 372 and 378 have the same electrical polarity, while the second, fourth and fifth electrodes 369, 371, 374, 376 and 377 have the opposite electrical polarity to the others. Two electrode terminals P-P' are constructed. That is, the electrodes disposed inside the grooves constructed opposite each other in the thickness (z' axis) direction have the same electrical polarity. Also, the electrodes disposed opposite each other across adjoining grooves or adjoining step difference portion and groove have opposite electrical polarity.

Now, when a direct voltage is applied between the electrode terminals P-P' (P terminal: plus, P' terminal: minus), an electric field  $E_x$  occurs in the arrow direction as shown in FIG. 20. As the electric field  $E_x$  occurs perpendicular to the electrodes disposed on the tuning fork base, the electric field  $E_x$  has a very large value and a large distortion occurs at the tuning fork base, so that a flexural mode, tuning fork, quartz crystal resonator is obtained with a small series resistance  $R_1$  and a high quality factor  $Q$ , even if it is miniaturized.

FIG. 21 shows a plan view of a flexural mode quartz crystal resonator 379 which constructs a quartz crystal unit of the tenth embodiment of the present invention. The resonator 379 comprises tuning fork tines 380, 381 and tuning fork base 382. The tines 380 and 381 have step difference portions 383, 384 along the direction of length thereof and medium surface portions 383b, 384b respectively, with the step difference portions 383 and 384 extending into the base 382. In addition, the base 382 has the groove 385 between the step difference portions 383 and 384.

FIG. 22 shows a N-N' cross-sectional view of the tuning fork base 382 for the flexural mode, tuning fork, quartz crystal resonator 379 of FIG. 21. In FIG. 22, the shape of the elec-

trode construction within the tuning fork base **382** for the quartz crystal resonator of FIG. **21** is described in detail. The section of the tuning fork base **382** which couples to the tuning fork tine **380** has the step difference portions **383**, **386** and the medium surface portions **383b**, **386d** cut into the obverse and the reverse faces of the base **382**. Also, the section of the tuning fork base **382** which couples to the tuning fork tine **381** has the step difference portions **384**, **387** and the medium surface portions **384b**, **387d** cut into the obverse and the reverse faces of the base **382**. In addition to these step difference portions, the tuning fork base **382** has the groove **385** cut between the step difference portions **383** and **384**, and also, the base **382** has the groove **388** cut between the step difference portions **386** and **387**.

Furthermore, the step difference portions **383** and **386** have the first electrodes **393** and **395** which are connected to electrodes disposed on the medium surface portions **383b** and **386d**, both of which have the same electrical polarity, the grooves **385** and **388** have the second electrodes **389** and **391** both of the same electrical polarity and the third electrodes **390**, **392** both of the same electrical polarity, the step difference portions **384** and **387** have the fourth electrodes **394** and **396** which are connected to electrodes disposed on the medium surface portions **384b** and **387d**, both of which have same electrical polarity and the sides of the base **382** have the fifth and sixth electrodes **397** and **398** which extend into the sides of the tines **380** and **381** respectively, each of which has opposite electrical polarity. In more detail, the first, third, and sixth electrodes **393**, **395**, **390**, **392** and **398** have the same electrical polarity, while the second, fourth and fifth electrodes **389**, **391**, **394**, **396** and **397** have the opposite electrical polarity to the others. Two electrode terminals U-U' are constructed. That is, the electrodes disposed inside the grooves constructed opposite each other in the thickness (z' axis) direction have the same electrical polarity. Also, the electrodes disposed opposite each other across adjoining step difference portion and groove have opposite electrical polarity. In addition, the medium surface portions extend to a side of the tuning fork tines as described in the above embodiments.

Now, when an alternating current (AC) voltage is applied between two electrode terminals U-U', an electric field  $E_x$  occurs alternately along the arrow directions shown by the solid and broken lines. As a result, a flexural mode is generated in the inverse phase. In addition, as the electric field  $E_x$  occurs perpendicular to the electrodes between the electrodes disposed on the sides of the grooves and the step difference portions, the electric field  $E_x$  becomes large, namely, a markedly large distortion occurs at the tuning fork base, so that a flexural mode, tuning fork, quartz crystal resonator is obtained with a small series resistance  $R_1$  and a high quality factor  $Q$  when it is miniaturized. In the this embodiments, though the electrodes **397** and **398** which are of opposite electrical polarity at both sides of the tuning fork base **382**, are disposed, the present invention is not limited to this, for example, the present invention includes the construction of the electrodes **397** and **398** being not disposed on the both sides or the construction of the electrodes **397** and **398** being connected to electrodes disposed on the respective adjoining medium surface portions. This electrode construction is also applied to that of both outside faces of the tuning fork tines.

FIG. **23** shows a plan view of a quartz crystal unit **400** of the eleventh embodiment of the present invention and omitting a lid. The quartz crystal unit **400** comprises a case **401**, two flexural mode, tuning fork, quartz crystal resonators **402**, **403** and a lid not shown in FIG. **23**. The one tuning fork, quartz crystal resonator **402** comprises tuning fork tines **404**, **405**

and tuning fork base **406** and similarly, the other tuning fork, quartz crystal resonator **403** comprises tuning fork tines **407**, **408** and tuning fork base **409**. The tuning fork bases **406** and **409** for the resonators **402** and **403** are formed integrally via a connecting portion **410**. In addition, the two quartz crystal resonators are formed with an angle  $\phi$  of separation of  $0^\circ$  to  $30^\circ$ . An object of embodiments of the present invention may be achieved even if the same-designed resonators have the angle  $\phi=0^\circ$  because flexural mode quartz crystal resonators of tuning fork type, which are manufactured in mass production, have a distribution of frequency temperature behaviours due to manufacturing tolerances. In other words there will be small differences between the two resonators. Moreover, the quartz crystal resonators **402** and **403** in this embodiment have the same grooves and electrodes as those of the tuning fork, quartz crystal resonator **21** described in FIG. **2**, respectively. Also, it is possible to change a peak temperature point by changing a ratio of a thickness of groove and a thickness of tuning fork tines

Here, [formed integrally] implies that a plurality of individual flexural mode, tuning fork, quartz crystal resonators are connected and formed between each tuning fork base via a connecting portion, when said quartz crystal resonators were removed from a quartz crystal wafer and also, includes the quartz crystal resonators cut and removed at the connecting portion after they were fixed on a mounting portion of a case by adhesives or solder.

Also, the tuning fork bases **406** and **409** are fixed at plural locations of a mounting portion **411** constructed at the case **401** by conductive adhesives **412**, **413**, **414** and **415** or solder. In this embodiment the bases are fixed at four locations of the mounting portion, but they may be fixed at location more than at least two. In addition, the tuning fork tines **404** and **405** have the grooves **416** and **417**, and the tuning fork tines **407** and **408** have the grooves **418** and **419**, in this embodiment the grooves constructed at the tuning fork tines extend into the tuning fork bases **406** and **409**, but the grooves may be constructed at the tuning fork tines at least.

Furthermore, four electrodes **420**, **421**, **422** and **423** are disposed on the mounting portion **411** and connected to the respective electrodes disposed on the tuning fork bases **406** and **409**, the electrodes of which have opposite electrical polarity. Namely, the tuning fork, quartz crystal resonator **402** and **403** in this embodiment have two electrode terminals, respectively. Additionally, as an another example of the electrode construction in this embodiment, at least two electrodes, for example, the electrodes **421** and **422** may be constructed such as common electrode (one electrode).

In addition, it is not visible in FIG. **23**, but the four electrodes **420**, **421**, **422** and **423** disposed on the mounting portion **411** extend into the reverse face of the case **401** or at least two of said electrodes are of the common electrode and three electrodes or two electrodes are disposed on the reverse face of the case **401**.

In more detail, the electrodes disposed on the reverse face of the case are constructed so that the flexural mode, tuning fork, quartz crystal resonators **402** and **403** are connected electrically in parallel. Namely, when two resonators **402** and **403** are excited by an electrical signal, both resonators vibrate in flexural mode in parallel electrically.

Thus, by constructing two flexural mode quartz crystal resonators of tuning fork type which are connected at each tuning fork base via a connecting portion and formed integrally with an angle  $\phi$  of separation no more than  $30^\circ$  between each resonator, each flexural mode, tuning fork, quartz crystal resonator has a different frequency temperature behaviour dependent on the angle  $\phi$ . Namely, flexural mode, tuning fork,

quartz crystal resonators can be obtained with different peak temperature points. In addition, an improvement of the frequency temperature behaviour for the tuning fork, quartz crystal resonator can be performed by electrically connecting the two quartz crystal resonators of tuning fork type in parallel. In order to get excellent frequency temperature behaviour, frequency difference for the both resonators **402** and **403** may be preferably less than 30 ppm. An electrical connection diagram for both flexural mode, tuning fork, quartz crystal resonators **402**, **403** is shown in FIG. **24**. The resonators are connected in parallel electrically.

FIG. **25** shows an example of frequency temperature behaviour of the quartz crystal unit of said eleventh embodiment with the above-described flexural mode, tuning fork, quartz crystal resonators **402**, **403**. The quartz crystal resonator **402** shown in FIG. **23** has frequency temperature behaviour **430** whose peak temperature point is approximately 30° C., while the resonator **403** shown in FIG. **23** has frequency temperature behaviour **431** whose peak temperature point is approximately 10° C. The compensated frequency temperature behaviour for both quartz crystal resonators connected in parallel electrically is shown by the curve **432**. Thus, the quartz crystal unit with the integrally formed flexural mode, tuning fork, quartz crystal resonator embodying the present invention may be miniaturized and obtained with excellent frequency temperature behaviour.

FIG. **26** shows a plan view of a quartz crystal unit **450** of the twelfth embodiment of the present invention and omitting a lid. The quartz crystal unit **450** comprises a case **451**, two flexural mode, tuning fork, quartz crystal resonators **452**, **453** and a lid not shown in FIG. **26**. The two resonators **452** and **453** each of which comprises tuning fork tines and tuning fork base, are connected at each tuning fork base via connecting portion **455** and formed integrally by an etching method, in more detail, by a chemical or physical or mechanical method. In this embodiment, a dividing portion **454** between both quartz crystal resonators **452** and **453** is constructed at the case **451** to prevent interference in vibration for the both resonators **452** and **453**. Also, a height of the dividing portion **454** may be the same one as the case **451** or may be lower than that of the case **451**. Moreover, the quartz crystal resonators **452** and **453** have the same grooves and electrodes as those of the tuning fork, quartz crystal resonator **21** described in FIG. **2**, respectively.

In this embodiment, also, though the dividing portion **454** is constructed at the case **451** to prevent the interference in vibration for two flexural mode, tuning fork, quartz crystal resonators **452** and **453**, the interference in vibration for both resonators **452** and **453** can be prevented by constructing a dividing portion between the both resonators **452** and **453**, formed integrally with them. In addition, the construction of grooves and electrodes in this embodiment is not shown in FIG. **26**, but it is same as that of FIG. **23**.

In FIGS. **23** and **26**, two flexural mode, tuning fork, quartz crystal resonators formed integrally are housed in a case of a quartz crystal unit, each of which has the same grooves and electrodes as those of the flexural mode, tuning fork, quartz crystal resonator housed in the case **2** of the quartz crystal unit shown in FIG. **1**, but, instead of said resonators the flexural mode, tuning fork, quartz crystal resonators shown in FIGS. **5-22** may be housed in the case of the quartz crystal unit. In more detail, the same-designed resonators may be housed in the case or the different-designed resonators may be housed in the case. In addition, the same effect as that described in FIG. **25** can be also obtained by using at least one of two

resonators, which is the flexural mode, tuning fork, quartz crystal resonator of the present invention shown in FIGS. **2-22**.

Namely, by electrically connecting two flexural mode, tuning fork, quartz crystal resonators in parallel, a quartz crystal unit can be obtained with a small frequency change versus temperature because an improvement of frequency temperature behaviour can be performed, and simultaneously, when two pieces of quartz crystal resonators with the same series resistance  $R_1$  are used, a compound quartz crystal resonator formed from embodiments of the present invention has about half the series resistance  $R_1$ . Thus, a quartz crystal unit with flexural mode, tuning fork, quartz crystal resonators can be realized with a small series resistance.

Next, a method of manufacturing a quartz crystal unit of the present invention is described in detail, according to the manufacturing steps.

FIG. **27** shows an embodiment of a method of manufacturing a quartz crystal unit of the present invention and a step diagram embodying the present invention. The signs of S-1 to S-12 are the step numbers. First, S-1 shows a cross-sectional view of a quartz crystal wafer **40**. Next, in S-2 a (first) metal film **41** comprising chromium and gold, namely, chromium and gold on the chromium are, respectively, disposed on upper and lower faces of the quartz crystal wafer **40** by an evaporation method or a sputtering method. In addition, a (first) resist **42** is spread on [said] the metal film **41** in S-3, and after the metal film **41** and the resist **42** [were] are removed except those of a tuning fork shape by a photo-lithographic process and an etching process, the tuning fork shape with tuning fork tines **43,44** and a tuning fork base **45**, as be shown in S-4, is integrally formed by a chemical etching [process.] process, namely, in a first etching process. In FIG. **27** the formation of a piece of tuning fork shape is shown, but, a number of tuning fork shapes are actually formed in a piece of quartz crystal wafer.

Similar to the steps of S-2 and S-3, [the] a (second) metal film and a (second) resist are spread again on the tuning fork shape of S-4 and grooves **46, 47, 48** and **49** each of which has two step difference portions i.e., two stepped portions including a first stepped portion and a second stepped portion opposite the first stepped portion in the width direction along the length direction of the tuning fork tines, are formed [at] in two of main surfaces (e.g., in first and second opposite main surfaces) of each of the tuning fork tines **43, 44** by [the] a photo-lithographic process and [the] an etching process, and the shape of S-5 is obtained after all of the resist and the metal film [were] are removed. Thus, at least one of the grooves **46, 47, 48** and **49** is formed after the tuning fork tines **43, 44** are formed. Namely, at least one of the grooves **46, 47** of the tuning fork tine **43** is formed after the tuning fork tine **43** is formed, and at least one of the grooves **48, 49** of the tuning fork tine **44** is formed after the tuning fork tine **44** is formed. In other words, the step of forming the tuning fork tines **43, 44** is performed before the step of forming the groove formed in each of two of the main surfaces (e.g., in each of the first and second opposite main surfaces) of each of the tuning fork tines **43, 44**. In addition, a (third or second) metal film and a (third or second) resist are spread again on the shape of [S 5] S-5, namely, the metal film is disposed on each of the first and second opposite main surfaces and first and second opposite side surfaces of each of the tuning fork tines **43, 44**, and a surface of the groove formed in each of the first and second opposite main surfaces of each of the tuning fork tines **43, 44** and the resist is disposed on the metal film, and electrodes which are of opposite electrical polarity, are disposed on [sides] the first and second opposite side surfaces of the

tuning fork tines 43, 44 and inside the grooves thereof, as be shown in S-6. As the result, a quartz crystal tuning fork resonator capable of vibrating in a flexural mode is obtained. In addition, the resist disposed on the metal film is removed before the step of mounting the quartz crystal tuning fork resonator on a mounting portion in an interior space of a case, as be shown in S-6.

Namely, electrodes 50, 53 disposed on the [sides] first and second opposite side surfaces of the tuning fork tine 43 and electrodes 55, 56 disposed inside the grooves 48, 49 i.e., on surfaces or on the first and second stepped portions of the grooves 48, 49 of the tuning fork tine 44 have the same electrical polarity. Similarly, electrodes 51, 52 disposed inside the grooves 46, 47 i.e., on surfaces or the first and second stepped portions of the grooves 46, 47 of the tuning fork tine 43 and electrodes 54, 57 disposed on the [sides] first and second side surfaces of the tuning fork tine 44 have the same electrical polarity. In addition, each of the electrodes 51, 52, 55 and 56 extends on a surface in the width direction adjoining the groove, namely, an electrode is disposed on the surface which is one of the first and second opposite main surfaces. In other words, the electrodes 50, 53 disposed on the first and second opposite side surfaces of the tuning fork tine 43 are connected to the electrodes 55, 56 disposed on the first and second stepped portions of the grooves formed in the first and second opposite main surfaces of the tuning fork tine 44 and the electrode disposed on each of the first and second opposite main surfaces of the tuning fork tine 44 to form a first electrode terminal, and the electrodes 54, 57 disposed on the first and second opposite side surfaces of the tuning fork tine 44 are connected to the electrodes 51, 52 disposed on the first and second stepped portions of the grooves formed in the first and second opposite main surfaces of the tuning fork tine 43 and the electrode disposed on each of the first and second opposite main surfaces of the tuning fork tine 43 to form a second electrode terminal. Two electrode terminals are, therefore, constructed. In more detail, when an alternating current (AC) voltage is applied between the two electrode terminals, the tuning fork tines are capable of vibrating in a flexural mode [in] of an inverse phase because said electrodes disposed on [step difference] the stepped portions of the grooves and the electrodes disposed opposite [to] the said electrodes have opposite electrical polarity. In the step of S-6, a piece of [tuning fork] quartz crystal tuning fork resonator which is capable of vibrating in a flexural mode is shown in [a] the quartz crystal wafer, but a number of [tuning fork] quartz crystal tuning fork resonators are actually formed in the quartz crystal wafer. In addition, a resonance frequency [for said] of each of the quartz crystal tuning fork resonators is adjusted at least twice and at least once of the at least twice adjustment of the resonance frequency [for said] of each of the quartz crystal tuning fork resonators is performed in the quartz crystal wafer by a laser method or an evaporation method or a plasma etching [method, such] method so that the resonance frequency [for said] of each of the quartz crystal tuning fork resonators is within a range of -9000 ppm to +5000 ppm (parts per million) to a nominal frequency that is within a range of 10 kHz to 200 kHz. The adjustment of frequency by the laser method or the plasma etching method is performed by trimming a mass disposed on the tuning fork tines and the adjustment of frequency by [an] the evaporation method is performed by adding a mass on the tuning fork tines. Namely, by those methods [can change] the resonance frequency of [said resonators.] each of the quartz crystal tuning fork resonators can be changed.

In this embodiment, the tuning fork shape is formed from the step of S-3 and after that, the grooves are formed at the

tuning fork tines, namely, the tuning fork tines 43, 44 are formed before the grooves 46, 47, 48 and 49 of the tuning fork tines 43, 44 are formed. In other words, the step of forming the tuning fork tines 43, 44 is performed before the step of forming the groove formed in each of two of the main surfaces (e.g., in each of the first and second opposite main surfaces) of each of the tuning fork tines 43, 44, but this invention is not limited to [said embodiment, for example, the] such embodiment. For example, the grooves 46, 47, 48 and 49 are first formed from the step of S-3 and after that, the tuning fork shape having the tuning fork tines 43, 44 and the tuning fork base 45 may be [formed] formed, namely, the grooves 46, 47, 48 and 49 are formed before the tuning fork tines 43, 44 are formed. In more detail, a plurality of grooves 46, 47, 48 and 49 are formed in first and second opposite surfaces of the quartz crystal wafer and after that, the tuning fork tines 43, 43 are formed so that a groove is located in each of the first and second opposite main surfaces of each of the tuning fork tines 43, 44. In other words, the step of forming the grooves 46, 47, 48 and 49 in the first and second opposite surfaces of the quartz crystal wafer is performed before the step of forming the tuning fork tines 43, 44 so that the groove is located in each of the first and second opposite main surfaces of each of the tuning fork tines 43, 44 or the tuning fork shape having the tuning fork tines 43, 44 and the tuning fork base 45 and the grooves 46, 47, 48 and 49 may be formed at the same [time.] time, namely, the tuning fork tines 43, 44 are formed simultaneously with the grooves 46, 47, 48 and 49 formed in the first and second opposite main surfaces of each of the tuning fork tines 43, 44. In addition, the grooves each of which has two [step difference] stepped portions along the direction of length of the tuning fork [tines,] tines are formed in this embodiment, but, instead of the grooves, [step difference] stepped portions and medium surface portions may be formed.

There are two methods of A and B in the following step, as be shown by arrow signs. For the step of A the tuning fork base 45 of the formed flexural mode, tuning fork, quartz crystal resonator 60 is first fixed on a mounting portion 59 in an interior space of a case 58 by conductive adhesives 61 or solder, as be shown in S-7. Second, the second adjustment of the resonance frequency for the resonator 60 is performed by a laser method 62 or an evaporation method or a plasma etching method in [S-8, such] S-8 so that the resonance frequency is within a range of -100 ppm to +100 ppm to the nominal frequency. Finally, the case 58 and lid 63 are connected via a glass 64 with the low melting point or a metal in S-9. In this case, the connection of the case and the lid is performed in a vacuum to obtain good electrical characteristics because the case 58 has no hole to close it in a vacuum. Additionally, though it is not visible in FIG. 27, the third adjustment of the resonance frequency may be performed by using a laser after the step of the connection of S-9 to get a small frequency deviation to the nominal frequency. As a result of which it is possible to get the resonance frequency within a range of -30 ppm to +30 ppm to the nominal frequency. In general, the nominal frequency is less than 200 kHz, and especially, 32.768 kHz is widely used in communication equipment as a time standard.

For the step of B the tuning fork base 45 of the formed flexural mode, tuning fork, quartz crystal resonator 60 is first fixed on a mounting portion 59 in an interior space of a case 65 by conductive adhesives 61 or solder in S-10, Second, in S-11 the case 65 and lid 63 are connected by the same way as that of S-9 and the second adjustment of the resonance frequency is performed in a vacuum or in a nitrogen [gas, such] gas so that the resonance frequency is within a range of -50

ppm to +50 ppm to the nominal frequency. Finally, a *through* hole 67 constructed at the case 65 is closed in a vacuum using such a metal 66 as solder or a glass with the low melting point in S-12. Also, similar to the step of A, the third adjustment of the resonance frequency may be performed by using a laser after the step of S-12 to get a small frequency deviation to the nominal frequency. As a result of which it is possible to get the resonance frequency within a range of -30 ppm to +30 ppm to the nominal frequency. In this embodiment, the second adjustment of the resonance frequency is performed before the hole is closed in vacuum, but may be performed after the hole [was] is closed in vacuum. Also, the hole is constructed at the case, but may be constructed at the lid.

In this embodiment, a method of manufacturing a quartz crystal unit with a piece of flexural mode, tuning fork, quartz crystal resonator is described in detail, but a quartz crystal unit with a plurality of individual flexural mode, tuning fork, quartz crystal resonators is also manufactured similar to the above-described steps.

Namely, a plurality of individual tuning fork shapes with tuning fork tines and tuning fork base which are connected at each tuning fork base via a connecting portion, are formed from the step of S-3 (S-4), in addition, grooves are formed at each tuning fork tine or at each tuning fork tine and each tuning fork base in S-5 and electrodes disposed on a plurality of individual flexural mode, tuning fork, quartz crystal resonators each of which is capable of vibrating in inverse phase, are constructed so that the tuning fork, quartz crystal resonators are electrically connected in parallel in S-6, and after that, the quartz crystal unit of the present invention is accomplished by the steps of A (S-7 to S-9) or B (S-10 to S-12). In order to get a small frequency difference of between at least two tuning fork, quartz crystal resonators, further frequency adjustment for the resonators may be performed by laser after the step of S-9 or S-12.

Therefore, the quartz crystal units of the present invention manufactured by the above-described method are miniaturized and realized with a small series resistance R1, a high quality factor Q and low price.

In addition, each of the flexural mode, tuning fork, quartz crystal resonators shown in FIGS. 1, 5, 7, 8, 9, 19 and 21 embodying the present invention [have] has two [pieces] sets of [step difference portion] stepped portions each of which confronts each other as a groove [(comprising generally, four step difference portions), each of which faces each other.] comprising four stepped portions. In more detail, the [rectangular] grooves each of which has a rectangular shape in plan view are [shown in the plan views,] shown, but this invention is not limited to this, for example, this invention also includes a shape with at least two [step difference] stepped portions.

Likewise, in the present embodiments a flexural mode quartz crystal resonator of tuning fork type has two tuning fork tines, but embodiments of the present invention include a plurality of tuning fork tines. Embodiments of the present invention also include flexural mode, tuning fork, quartz crystal resonators which are connected and formed integrally at the tuning fork bases consisting of more than three component pieces of tuning fork, quartz crystal resonator. Also, embodiments of the present invention include the teaching that each resonator consisting of a plurality of flexural mode, tuning fork, quartz crystal resonators which are connected and formed integrally at each tuning fork base, which may have different resonator shapes and different electrode positions.

Moreover, in the embodiments of the quartz crystal units of the present invention shown in FIGS. 23 and 26, an angle  $\phi$  is

constructed between two flexural mode, tuning fork, quartz crystal resonators to get the two resonators with different frequency temperature behaviour. Instead of the angle  $\phi$ , it is also possible to obtain two tuning fork, quartz crystal resonators with different frequency temperature behaviour by designing the two resonators with different dimensions. As a result of which the respective resonators can be obtained with different peak temperature point.

In addition, though integrally formed two flexural mode, tuning fork, quartz crystal resonators are housed in the case of the quartz crystal units in the embodiments of FIGS. 23 and 26, this invention is not limited to this, but also includes integrally formed tuning fork, quartz crystal resonators more than three.

Also, each flexural mode quartz crystal resonator is connected and formed integrally side by side via a connecting portion in the present embodiments as shown in FIGS. 23 and 26. However, the present invention is not limited to flexural mode, tuning fork, quartz crystal resonator connected and formed integrally side by side via a connecting portion, but includes the connection and integrated formation of any shapes at the tuning fork bases. In other words, the present invention includes integrally formed tuning fork, quartz crystal resonators with any shapes connected and formed integrally via connecting portion at each tuning fork base for a plurality of tuning fork, quartz crystal resonators.

Furthermore, though the quartz crystal units of FIGS. 23 and 26 embodying the present invention have integrally formed two flexural mode, tuning fork, quartz crystal resonators, respectively, the quartz crystal units of the present invention are not limited to these, but, may have at least one flexural mode, tuning fork, quartz crystal resonator. That is to say, at least one BAW (Bulk Acoustic Wave) resonator with vibration mode different from flexural mode or at least one SAW (Surface Acoustic Wave) resonator or at least one filter or at least one oscillator may be housed with said at least one tuning fork, quartz crystal resonator in a case of the present invention. For example, flexural mode, tuning fork, quartz crystal resonator and thickness shear mode quartz crystal resonator or width-extensional mode quartz crystal resonator or Lamé mode quartz crystal resonator or torsional mode quartz crystal resonator or MCF filter or SAW filter or TCXO (Temperature Compensated Crystal Oscillator) or VCXO (Voltage Controlled Crystal Oscillator) or XO (Crystal Oscillator). The above-described resonators and filters are generally formed from such a piezoelectric material as quartz crystal, and also formed by a chemical or mechanical or physical etching method.

Furthermore, two flexural mode, tuning fork, quartz crystal resonators are connected and formed integrally with an angle of  $\phi$  at each tuning fork base as shown in the embodiment of FIG. 23, and also embodiments of the present invention include the following flexural mode, tuning fork, quartz crystal resonator which has the same effect as said resonators with an angle of  $\phi$ , namely, the tuning fork bases of the plurality of the flexural mode, tuning fork, quartz crystal resonators are formed in parallel and one of the plurality of component resonators is at least designed and formed so that two tuning fork tines turn to the inside with an angle of  $\phi$  or turn to the outside with an angle of  $\phi$ . It is needless to say that these resonators are connected and formed integrally at the tuning fork bases via connecting portion.

As mentioned above, by providing a quartz crystal unit with at least one flexural mode, tuning fork, quartz crystal resonator with the resonator shape and the electrode construc-

tion in embodiments of the present invention and its manufacturing method, the outstanding effects may be obtained as follow:

- (1) As the grooves consisting of at least four step difference portions are constructed including a portion of the central line of the tuning fork tines, an electric field occurs perpendicular to the electrodes, so that a flexural mode, tuning fork, quartz crystal resonator with a small series resistance  $R_1$  and a high quality factor  $Q$  is obtained because the electromechanical transformation efficiency becomes large. A quartz crystal unit is, therefore, obtained with good characteristics of the resonator.
- (2) A flexural mode, tuning fork, quartz crystal resonator is obtained with a small series resistance  $R_1$ , even if it is miniaturized. Therefore, a miniaturized quartz crystal unit can be obtained because the miniaturized tuning fork, quartz crystal resonator is housed in a case.
- (3) As two flexural mode, tuning fork, quartz crystal resonators are formed integrally by an etching process and are connected in parallel electrically, a quartz crystal unit with an integrally formed and miniaturized quartz crystal resonator can be realized with excellent frequency temperature behaviour.
- (4) A low price quartz crystal resonator can be realized because a quartz crystal resonator is formed integrally by an etching process which makes it possible to form many resonators on a piece of quartz wafer. As a result of which a low priced quartz crystal unit can be also realized because the resonator is housed in a case.
- (5) As the prior art quartz crystal resonators are based on the tuning fork type, it is easy to fix the flexural mode, tuning fork, quartz crystal resonators on a mounting portion of a quartz crystal unit. As a result, energy losses at fixing caused by the vibration of tuning fork tines decrease and quartz crystal units with the resonators obtained are shock resistant.
- (6) As there is a plurality of grooves on the tuning fork base and electrodes of opposite polarities are disposed opposite the sides of adjoining grooves, the distortion at the tuning fork base is markedly large, so that a quartz crystal unit with a miniaturized flexural mode quartz crystal resonator of tuning fork type is obtained with a small series resistance  $R_1$  and a high quality factor  $Q$ .
- (7) As grooves are constructed including the central line of tuning fork tine, and electrodes are disposed on said grooves and said grooves extend to tuning fork base, the quantity of distortion at the tuning fork base becomes remarkably large. Therefore, a quartz crystal unit with a miniaturized flexural mode, tuning fork, quartz crystal resonator is obtained with a small series resistance  $R_1$  and a high quality factor  $Q$  because the electromechanical transformation efficiency gets large.
- (8) As electrodes are disposed on step difference portions constructed at the obverse and the reverse faces of tuning fork tines along the length direction thereof and the sides of the tuning fork tines opposite said electrodes have electrodes of opposite polarity to said electrodes, the electromechanical transformation efficiency becomes very large. As a result, a flexural mode, tuning fork, quartz crystal resonator can be realized with a small series resistance  $R_1$  and a high quality factor  $Q$  and also, a quartz crystal unit with said resonator is obtained with a high quality.
- (9) A markedly narrow width tuning fork tines can be obtained maintaining sufficiently large electromechanical transformation efficiency because the step difference is

constructed on the tuning fork tines. As a result of which, a quartz crystal unit with a miniaturized quartz crystal resonator can be obtained.

- (10) As a plurality of flexural mode, tuning fork, quartz crystal resonators are formed integrally and connected in parallel electrically, the compound series resistance  $R_1$  for the compound resonator becomes small. For example, when two pieces of resonator with the same series resistance  $R_1$  are used, a compound resonator formed from embodiments of the present invention have about half the series resistance  $R_1$ . Therefore, a compound series resistance  $R_1$  can be decreased still more by increasing the number of resonators which are formed integrally. Namely, a quartz crystal unit with small series resistance  $R_1$  can be realized by housing a plurality of resonators in a case.
- (11) As a quartz crystal unit has a plurality of flexural mode, tuning fork, quartz crystal resonators which are formed integrally, and connected in parallel electrically, the function can be maintained as a quartz crystal unit, even if one of the plurality of resonators is broken by some cause, for example, by shock.
- (12) As grooves are constructed including the central line of tuning fork tine, and electrodes are disposed on said grooves and said grooves extend to tuning fork base, in addition, as further grooves are constructed between the extending grooves, the quantity of distortion at the tuning fork base becomes remarkably large. Therefore, a quartz crystal unit with a miniaturized flexural mode, tuning fork, quartz crystal resonator is obtained with a small series resistance  $R_1$  and a high quality factor  $Q$  because the electromechanical transformation efficiency gets large.
- (13) As electrodes are disposed on step difference portions constructed at the obverse and the reverse faces of tuning fork tines along the length direction thereof and the sides of the tuning fork tines opposite said electrodes have electrodes of opposite polarity to said electrodes, in addition, as said step difference portions extend to tuning fork base and further grooves are constructed between the extending step difference portions, the electromechanical transformation efficiency becomes very large because the quantity of distortion at the tuning fork base becomes remarkably large. As a result, a flexural mode, tuning fork, quartz crystal resonator can be realized with a small series resistance  $R_1$  and a high quality factor  $Q$  and also, a quartz crystal unit with said resonator is obtained with a high quality.
- (14) As a miniaturized flexural mode, tuning fork, quartz crystal resonator is housed in a case of a quartz crystal unit, a light quartz crystal unit can be obtained.
- (15) A low price quartz crystal unit can be realized because a method for manufacturing a quartz crystal unit is very simple and the manufacturing steps decrease.
- (16) A quartz crystal unit with high reliability can be obtained because ceramics or glass is used as a material of case and metal or glass is used as a material of lid.
- (17) As a plurality of flexural mode, tuning fork, quartz crystal resonators are not housed in a case of an individual quartz crystal unit, but, housed in a case of the same unit, a low price quartz crystal unit can be realized and simultaneously, a quartz crystal unit with excellent frequency temperature behaviour is obtained by electrically connecting these resonators in parallel.
- (18) A quartz crystal unit is obtained with a small frequency deviation because resonance frequency for a flexural mode, tuning fork, quartz crystal resonator is adjusted by laser after the resonator housed in a case was closed in vacuum.



(19) By showing a relationship of a groove and a dimension for a flexural mode, tuning fork, quartz crystal resonator, a miniaturized flexural mode, tuning fork, quartz crystal resonator which vibrates very easily in a fundamental mode with suppression of the second and the third overtone modes which are unwanted vibration modes, can be obtained with a small series resistance  $R_1$  and a high quality factor  $Q$ . As a result of which a miniaturized quartz crystal unit can be also obtained with a high quality.

(20) By constructing the electrodes and the step portions to connect step difference portions constructed along the direction of length of the tuning fork tines, a quartz crystal unit with a tuning fork, quartz crystal resonator capable of vibrating in fundamental mode very easily can be obtained with a small series resistance  $R_1$  and a high quality factor  $Q$  because the quantity of charges which generate on the step difference portions and the side faces of the tuning fork tines can be controlled and the second and third overtone modes for the resonator which are unwanted vibration modes can be substantially suppressed in vibration.

As described above, it will be easily understood that the quartz crystal units with at least one flexural mode, tuning fork, quartz crystal resonator with novel shapes and the novel electrode construction according to the present invention may have the same outstanding effects. In addition to this, while the present invention has been shown and described with reference to preferred embodiments thereof, it will be understood by those skilled in the art that the changes in shape and electrode construction can be made therein without departing from the spirit and scope of the present invention.

What is claimed is:

1. A method for manufacturing a quartz crystal unit, comprising the steps of:

forming at least one quartz crystal tuning fork resonator by etching a quartz crystal wafer to form a quartz crystal tuning fork base, a plurality of quartz crystal tuning fork tines connected to the quartz crystal tuning fork base, and at least one groove [having a plurality of stepped portions] in at least one of [opposite] main surfaces of each of *two* of the quartz crystal tuning fork tines, and disposing a first electrode on at least one of the stepped portions of at least one of the grooves and a second electrode on at least one side surface of each] *so that a width of the at least one groove formed in the at least one of the main surfaces of each of the two of the quartz crystal tuning fork tines is greater than a distance in the width direction of the at least one groove measured from an outer edge of the at least one groove to an outer edge of the corresponding one of the two of the quartz crystal tuning fork tines;*

[adjusting at least twice and in different steps a frequency of oscillation of the quartz crystal tuning fork resonator;] *disposing an electrode on a surface of the at least one groove formed in the at least one of the main surfaces of one of the two of the quartz crystal tuning fork tines and disposing an electrode on a surface of the at least one groove formed in the at least one of the main surfaces of the other of the two of the quartz crystal tuning fork tines so that the electrode disposed on the surface of the at least one groove formed in the at least one of the main surfaces of the one of the two quartz crystal tuning fork tines has an electrical polarity opposite to an electrical polarity of the electrode disposed on the surface of the at least one groove formed in the at least one of the main surfaces of the other of the two quartz crystal tuning fork tines;*

providing a case having [an interior space and an open end communicating with the interior space] *a mounting portion;*

[providing a lid for covering the open end of the case;] *after the disposing step, mounting the quartz crystal tuning fork resonator [in the interior space] on the mounting portion of the case; and*

[connecting the lid to the case to cover the open end thereof] *after the mounting step, adjusting at least once a frequency of oscillation of the quartz crystal tuning fork resonator.*

[2. A method according to claim 1; wherein the step of forming the groove comprises the step of forming a through-hole in each of the quartz crystal tuning fork tines extending through the opposite main surfaces thereof.]

[3. A method according to claim 1; wherein the step of forming a plurality of quartz crystal tuning fork tines comprises the step of forming a first quartz crystal tuning fork tine and a second quartz crystal tuning fork tine; wherein the step of forming the first and second electrodes comprises the steps of forming the first electrode on each of two of the stepped portions of the groove in at least one of the opposite main surfaces of each of the first and second quartz crystal tuning fork tines and forming the second electrode on each of two of the side surfaces of each of the first and second quartz crystal tuning fork tines; and wherein the first electrode disposed on each of two of the stepped portions of the groove of the first quartz crystal tuning fork tine is connected to the second electrode disposed on each of two of the side surfaces of the second quartz crystal tuning fork tine to form a first electrode terminal, and the second electrode disposed on each of two of the side surfaces of the first quartz crystal tuning fork tine is connected to the first electrode disposed on each of two of the stepped portions of the groove of the second quartz crystal tuning fork tine to form a second electrode terminal so that the quartz crystal tuning fork resonator vibrates in a flexural mode of an inverse phase when an alternating current voltage is applied between the first electrode terminal and the second electrode terminal.]

[4. A method according to claim 3; wherein the at least one groove is formed in each of the first main surface and the second main surface of each of the quartz crystal tuning fork tines so that a ratio  $W_2/W$  is in the range of 0.35 to 0.85, where  $W_2$  represents a width of the groove and  $W$  represents a width of each of the quartz crystal tuning fork tines.]

[5. A method according to claim 3; wherein the adjusting step comprises the step of adjusting the frequency of oscillation of the quartz crystal tuning fork resonator by at least one of a laser method and evaporation and etching methods so that the frequency of oscillation of the quartz crystal tuning fork resonator is about 32.768 Hz with a frequency deviation within the range of -9000 PPM to +5000 PPM.]

[6. A method according to claim 3; wherein the side surfaces of the first and second quartz crystal tuning fork tines comprise a first side surface and a second side surface, the first side surface of the first quartz crystal tuning fork tine confronting the first side surface of the second quartz crystal tuning fork tine; and wherein the stepped portions of the groove comprises a first stepped portion, a second stepped portion, and a third stepped portion connecting the first stepped portion to the second stepped portion, each of the first and second stepped portions being formed opposite to the first side surface of each of the first and second quartz crystal tuning fork tines.]

[7. A method according to claim 3; wherein the step of forming at least one quartz crystal tuning fork resonator comprises the steps of forming two of the quartz crystal tuning

fork resonators and integrally connecting together the two quartz crystal tuning fork resonators at their respective quartz crystal tuning fork bases at an angle of 30° or less.]

[8. A method according to claim 3; wherein the adjusting step comprises the step of adjusting the frequency of oscillation of the quartz crystal tuning fork resonator by at least one of a laser method and evaporation and etching methods after the quartz crystal tuning fork resonator is mounted in the interior space of the case so that the frequency of oscillation of the resonator is about 32.768 kHz with a frequency deviation within the range of -100 PPM to +100 PPM.]

[9. A method according to claim 8; wherein the step of forming at least one quartz crystal tuning fork resonator comprises the step of forming one quartz crystal tuning fork resonator capable of vibrating in a flexural mode of an inverse phase; and further comprising the step of forming one quartz crystal resonator capable of vibrating in a mode different from the flexural mode of an inverse phase.]

[10. A method according to claim 8; wherein the connecting step comprises the step of connecting the lid to the case using at least one of a metal and a glass with a low melting point.]

[11. A method according to claim 10; wherein the adjusting step comprises the step of adjusting the frequency of oscillation of the quartz crystal tuning fork resonator by a laser method after the connecting step so that the frequency of oscillation of the quartz crystal tuning fork resonator is about 32.768 kHz with a frequency deviation within the range of -30 ppm to +30 ppm.]

[12. A method according to claim 10; wherein the adjusting step comprises the step of adjusting the frequency of oscillation of the quartz crystal tuning fork resonator by a laser method after the connecting step so that the frequency of oscillation of the resonator is about 32.768 kHz with a frequency deviation within the range of -50 ppm to +50 ppm.]

[13. A method according to claim 12; wherein one of the case and the lid has a through-hole; and further comprising the step of disposing at least one of a metal and a glass into the through hole to maintain the interior space of the case in a vacuum.]

[14. A method according to claim 13; wherein the adjusting step comprises the step of adjusting the frequency of oscillation of the quartz crystal tuning fork resonator by a laser method after the disposing step so that the frequency of oscillation of the resonator is about 32.768 kHz with a frequency deviation within the range of -30 ppm to +30 ppm.]

[15. A method according to claim 3; wherein the forming step comprises the steps of forming the quartz crystal tuning fork tines in a first etching process and forming the corresponding grooves in a second etching process different from the first etching process; and wherein the step of forming the quartz crystal tuning fork tines is performed before the step of forming the corresponding grooves.]

[16. A method according to claim 3; wherein the forming step comprises the steps of forming the quartz crystal tuning fork tines in a first etching process and forming the corresponding grooves in a second etching process different from the first etching process; and wherein the step of forming the corresponding grooves is performed before the step of forming the quartz crystal tuning fork tines.]

[17. A method according to claim 1; wherein the adjusting step comprises the step of adjusting a frequency of oscillation of the quartz crystal tuning fork resonator to a preselected frequency with a frequency deviation within the range of -100 ppm to +100 ppm.]

[18. A method according to claim 17; wherein the preselected frequency is about 32.768 kHz.]

[19. A method according to claim 17; wherein a width of the groove formed in at least one of the opposite main surfaces of each of the quartz crystal tuning fork tines is greater than a distance in the width direction of the groove measured from an outer edge of the groove to an outer edge of the quartz crystal tuning fork tine.]

[20. A method according to claim 19; wherein the forming step comprises the steps of forming the quartz crystal tuning fork tines in a first etching process and forming the corresponding grooves in a second etching process different from the first etching process; and wherein the step of forming the quartz crystal tuning fork tines is performed before the step of forming the corresponding grooves.]

[21. A method according to claim 19; wherein the forming step comprises the steps of forming the quartz crystal tuning fork tines in a first etching process and forming the corresponding grooves in a second etching process different from the first etching process; and wherein the step of forming the corresponding grooves is performed before the step of forming the quartz crystal tuning fork tines.]

[22. A method according to claim 19; wherein the groove formed in at least one of the main surfaces of each of the quartz crystal tuning fork tines comprises a through hole.]

[23. A method according to claim 19; wherein the forming step comprises the steps of forming the quartz crystal tuning fork tines into a first quartz crystal tuning fork tine and a second quartz crystal tuning fork tine; forming a groove in each of opposite main surfaces of each of the first and second quartz crystal tuning fork tines; forming a first electrode on each of at least two of the stepped portions of the groove in each of the opposite main surfaces of the first and second quartz crystal tuning fork tines; forming a second electrode on each of two of side surfaces of each of the first and second quartz crystal tuning fork tines; connecting the first electrodes disposed on at least two of the stepped portions of the groove of the first quartz crystal tuning fork tine to the second electrodes disposed on two of the side surfaces of the second quartz crystal tuning fork tine to form a first electrode terminal; and connecting the second electrodes disposed on two of the side surfaces of the first quartz crystal tuning fork tine to the first electrodes disposed on at least two of the stepped portions of the groove of the second quartz crystal tuning fork tine to form a second electrode terminal; and further comprising the step of applying an alternating current voltage between the first electrode terminal and the second electrode terminal to vibrate the quartz crystal tuning fork resonator in a flexural mode of an inverse phase.]

[24. A method according to claim 23; wherein the forming step comprises the step of forming the first and second quartz crystal tuning fork tines simultaneously with the corresponding grooves.]

[25. A method according to claim 23; wherein a ratio  $W_2/W$  is in the range of 0.35 to 0.85, where  $W_2$  represents a width of the groove and  $W$  represents a width of each of the first and second quartz crystal tuning fork tines.]

[26. A method according to claim 25; wherein the connecting step comprises the step of connecting the lid to the case using at least one of a metal and a glass with a low melting point.]

[27. A method according to claim 25; wherein the quartz crystal tuning fork resonator has a fundamental mode of vibration and a second overtone mode of vibration; and wherein a series resistance  $R_1$  of the fundamental mode of vibration is less than a series resistance  $R_2$  of the second overtone mode of vibration.]

[28. A method according to claim 27; wherein one of the case and the lid has a through-hole; and further comprising

the step of disposing at least one of a metal and a glass into the through-hole to maintain the interior space of the case in a vacuum.]

[29. A method according to claim 27; further comprising the step of providing a CMOS inverter, a plurality of capacitors, and a plurality of resistors to form an oscillator having the quartz crystal tuning fork resonator.]

[30. A method according to claim 1; wherein the adjusting step comprises the steps of adjusting a frequency of oscillation of the quartz crystal tuning fork resonator to a first preselected frequency of oscillation, and adjusting the frequency of oscillation of the quartz crystal tuning fork resonator to a second preselected frequency of oscillation different from the first preselected frequency of oscillation.]

[31. A method according to claim 30; wherein the first preselected frequency of oscillation is about 32.768 kHz with a frequency deviation within the range of -9000 ppm to +5000 ppm; and wherein the second preselected frequency of oscillation is about 32.768 kHz with a frequency deviation within the range of -100 ppm to +100 ppm.]

[32. A method according to claim 30; wherein the at least one groove is formed in each of the opposite main surfaces of each of the quartz crystal tuning fork tines so that a ratio  $W_2/W$  is in the range of 0.35 to 0.85, where  $W_2$  represents a width of the groove and  $W$  represents a width of each of the first and second quartz crystal tuning fork tines.]

[33. A method according to claim 30, further comprising the step of etching the quartz crystal wafer to simultaneously form the quartz crystal tuning fork tines and the corresponding grooves by a single etching process.]

[34. A method according to claim 30, wherein the quartz crystal tuning fork resonator has a fundamental mode of vibration and a second overtone mode of vibration; and wherein a series resistance  $R_1$  of the fundamental mode of vibration is less than a series resistance  $R_2$  of the second overtone mode of vibration.]

[35. A method according to claim 34; wherein the at least one groove is formed in each of the opposite main surfaces of each of the quartz crystal tuning fork tines so that a width of at least one of the grooves in each of the opposite main surfaces of each of the quartz crystal tuning fork tines is greater than a distance in the width direction of the groove measured from an outer edge of the groove to an outer edge of the quartz crystal tuning fork tine; and wherein the forming step comprises the steps of forming the quartz crystal tuning fork tines into a first quartz crystal tuning fork tine and a second quartz crystal tuning fork tine; forming at least one groove in each of opposite main surfaces of each of the first and second quartz crystal tuning fork tines; forming a plurality of first electrodes on at least two of the stepped portions of the grooves in the opposite main surfaces of the first and second quartz crystal tuning fork tines; forming a plurality of second electrodes on side surfaces of each of the first and second quartz crystal tuning fork tines; connecting the first electrodes disposed on at least two of the stepped portions of the grooves of the first quartz crystal tuning fork tine to the second electrodes disposed on the side surfaces of the second quartz crystal tuning fork tine to form a first electrode terminal; and connecting the second electrodes disposed on the side surfaces of the first quartz crystal tuning fork tine to the first electrodes disposed on at least two of the stepped portions of the grooves of the second quartz crystal tuning fork tine to form a second electrode terminal; and further comprising the step of applying an alternating current voltage between the first electrode terminal and the second electrode terminal to vibrate the quartz crystal tuning fork resonator in a flexural mode of an inverse phase.]

[36. A method according to claim 35; wherein the forming step comprises the steps of forming the quartz crystal tuning fork tines in a first etching process and forming the corresponding grooves in a second etching process different from the first etching process; and wherein the step of forming the quartz crystal tuning fork tines is performed before the step of forming the corresponding grooves.]

37. A method according to claim 1; wherein the quartz crystal tuning fork resonator has an overall length and the at least one groove formed in the at least one of the main surfaces of each of the two of the quartz crystal tuning fork tines has a length; and further comprising the step of determining the overall length of the quartz crystal tuning fork resonator and the length of the at least one groove formed in the at least one of the main surfaces of each of the two of the quartz crystal tuning fork tines so that a series resistance  $R_1$  of a fundamental mode of vibration of the quartz crystal tuning fork resonator is less than a series resistance  $R_2$  of a second overtone mode of vibration thereof.

38. A method according to claim 1; wherein the two of the quartz crystal tuning fork tines comprise first and second quartz crystal tuning fork tines, and the main surfaces of each of the first and second quartz crystal tuning fork tines comprise a first main surface and a second main surface opposite the first main surface; wherein each of the first and second quartz crystal tuning fork tines has a first side surface and a second side surface opposite the first side surface, the first side surface of the first quartz crystal tuning fork tine confronting the first side surface of the second quartz crystal tuning fork tine; wherein the quartz crystal wafer has a first surface and a second surface opposite the first surface, each of the first main surfaces of the first and second quartz crystal tuning fork tines being formed at the first surface of the quartz crystal wafer; wherein the at least one groove is formed in the first main surface of each of the first and second quartz crystal tuning fork tines with a first stepped portion and a second stepped portion connected to the first stepped portion through a third stepped portion so that each of the first and second stepped portions of the at least one groove formed in the first main surface of the first quartz crystal tuning fork tine is formed opposite the first side surface of the first quartz crystal tuning fork tine and is directly connected to the third stepped portion, and so that each of the first and second stepped portions of the at least one groove formed in the first main surface of the second quartz crystal tuning fork and is directly connected to the third stepped portion; wherein the at least one groove formed in the first main surface of each of the first and second quartz crystal tuning fork tines has a fourth stepped portion directly opposite a fifth stepped portion in the length direction, the fourth stepped portion being directly connected to the first stepped portion and the fifth stepped portion being directly connected to the second stepped portion.

39. A method according to claim 38; further comprising the steps of providing a lid for covering an open end of the case, one of the lid and the case having a throughhole and the case having an interior space containing the mounting portion; forming the at least one groove in each of the first and second main surfaces of each of the first and second quartz crystal tuning fork tines so that a ratio  $W_2/W$  is in the range of 0.35 to 0.85, where  $W_2$  represents a width of the groove and  $W$  represents a width of each of the first and second quartz crystal tuning fork tines; adjusting the frequency of oscillation of the quartz crystal tuning fork resonator so that the frequency of oscillation thereof is about 32.768 kHz with a frequency deviation within the range of -100 ppm to +100 ppm; con-

necting the lid to the case to cover the open end thereof; and disposing a metal or a glass in the through hole to close the through hole in a vacuum.

40. A method according to claim 38; further comprising the step of providing a lid for covering an open end of the case, one of the lid and the case having a through hole, and the case having an interior space containing the mounting portion; wherein the adjusting step comprises adjusting in a vacuum the frequency of oscillation of the quartz crystal tuning fork resonator; and further comprising, after the mounting, and adjusting steps, the sequential steps of connecting the lid to the case to cover the open end thereof and disposing a metal or a glass in the through hole to close the through hole in a vacuum.

41. A method according to claim 38; further comprising the step of providing a lid for covering an open end of the case, one of the lid and the case having a through hole, and the case having an interior space containing the mounting portion; wherein the adjusting step comprises adjusting the frequency of oscillation of the quartz crystal tuning fork resonator so that the frequency of oscillation thereof is about 32.768 kHz with a frequency deviation within the range of  $-30$  ppm to  $+30$  ppm; and further comprising, after the mounting and adjusting steps, the sequential steps of connecting the lid to the case to cover the open end thereof and disposing a metal or glass in the through hole to close the through hole in a vacuum.

42. A method according to claim 38; wherein the step of forming the at least one groove comprises the step of forming a groove in each of the first and second main surfaces of each of the first and second quartz crystal tuning fork tines so that a ratio  $W_2/W$  is in the range of 0.35 to 0.85, where  $W_2$  represents a width of the groove and  $W$  represents a width of each of the first and second quartz crystal tuning fork tines; wherein the adjusting step comprises adjusting the frequency of oscillation of the quartz crystal tuning fork resonator so that the frequency of oscillation thereof is about 32.768 kHz with a frequency deviation within the range of  $-100$  ppm to  $+100$  ppm; and further comprising, after the mounting and adjusting steps, the step of connecting a lid to the case to maintain the quartz crystal tuning fork resonator in a vacuum.

43. A method according to claim 1; wherein the two of the quartz crystal tuning fork tines comprise first and second quartz crystal tuning fork tines each having a length, and the main surfaces of each of the first and second quartz crystal tuning fork tines comprise a first main surface and a second main surface opposite the first main surface; wherein the step of forming the at least one groove comprises the steps of forming a groove having at least two stepped portions including a first stepped portion and a second stepped portion in the first main surface of each of the first and second quartz crystal tuning fork tines so that each of the first and second stepped portions is formed along the length of each of the first and second quartz crystal tuning fork tines, and forming a groove having at least three stepped portions including a first stepped portion, a second stepped portion and a third stepped portion in the second main surface of each of the first and second quartz crystal tuning fork tines so that each of the first, second and third stepped portions is formed along the length of each of the first and second quartz crystal tuning fork tines and the first stepped portion is connected to the second stepped portion through a stepped portion, and so that each of the first and second stepped portions is directly connected to the stepped portion; and wherein the groove having the at least three stepped portions formed in the second main surface of each of the first and second quartz crystal tuning fork tines has a fourth stepped portion directly opposite a fifth

stepped portion in the length direction, the fourth stepped portion being directly connected to the first stepped portion and the fifth stepped portion being directly connected to the second stepped portion.

44. A method according to claim 38; wherein the step of forming the at least one groove comprises forming a groove in at least one of the first and second main surfaces of each of the first and second quartz crystal tuning fork tines; wherein the step of disposing the electrode comprises forming a first electrode on a surface of the groove formed in the at least one of the first and second main surfaces of each of the first and second quartz crystal tuning fork tines and forming a second electrode on each of the first and second side surfaces of each of the first and second quartz crystal tuning fork tines so that the first electrode formed on the surface of the groove formed in the at least one of the first and second main surfaces of the first quartz crystal tuning fork tine is connected to the second electrode formed on each of the first and second side surfaces of the second quartz crystal tuning fork tine, and the second electrode formed on each of the first and second side surfaces of the first quartz crystal tuning fork tine is connected to the first electrode formed on the surface of the groove formed in the at least one of the first and second main surfaces of the second quartz crystal tuning fork tine; and further comprising the steps of providing a lid for covering an open end of the case, connecting the lid to the case to cover the open end of the case, and disposing a metal or a glass in a through hole formed in one of the case and the lid to close the through hole in a vacuum after the connecting step.

45. A method according to claim 44; wherein the step of forming the at least one groove comprises the step of forming a groove having a first stepped portion, a second stepped portion and a third stepped portion connecting the first stepped portion to the second stepped portion in the second main surface of each of the first and second quartz crystal tuning fork tines, each of the first and second stepped portions being formed opposite the first side surface of each of the first and second quartz crystal tuning fork tines and being directly connected to the third stepped portion; and wherein the groove formed in the second main surface of each of the first and second quartz crystal tuning fork tines has a fourth stepped portion directly opposite a fifth stepped portion in the length direction, the fourth stepped portion being directly connected to the first stepped portion and the fifth stepped portion being directly connected to the second stepped portion.

46. A method according to claim 45; wherein the adjusting step comprises the step of adjusting in a vacuum the frequency of oscillation of the quartz crystal tuning fork resonator after the connecting step and before the disposing step.

47. A method according to claim 45; wherein the adjusting step comprises the step of adjusting the frequency of oscillation of the quartz crystal tuning fork resonator after the disposing step so that the frequency of oscillation thereof is about 32.768 kHz with a frequency deviation within the range of  $-30$  ppm to  $+30$  ppm.

48. A method according to claim 45; wherein the adjusting step comprises adjusting the frequency of oscillation of the quartz crystal tuning fork resonator before the connecting step.

49. A method according to claim 45; wherein the adjusting step comprises the step of adjusting the frequency of oscillation of the quartz crystal tuning fork resonator so that the frequency of oscillation thereof is about 32.768 kHz with a frequency deviation within the range of  $-9000$  ppm to  $+5000$  ppm.

50. A method according to claim 44; wherein the adjusting step comprises a first step of adjusting the frequency of oscillation of the quartz crystal tuning fork resonator to a first preselected frequency of oscillation after the disposing step of the first and second electrodes and before the mounting step; and a second step of adjusting the frequency of oscillation of the quartz crystal tuning fork resonator to a second preselected frequency of oscillation after the mounting step and before the connecting step.

51. A method according to claim 50; wherein the first preselected frequency of oscillation is about 32.768 kHz with a frequency deviation within the range of -9000 ppm to +5000 ppm; and wherein the second preselected frequency of oscillation is about 32.768 kHz with a frequency deviation within the range of -100 ppm to +100 ppm.

52. A method according to claim 44; wherein the adjusting step comprises the step of adjusting in a vacuum the frequency of oscillation of the quartz crystal tuning fork resonator after the connecting step and before the disposing step of the metal or the glass.

53. A method according to claim 44; wherein the adjusting step comprises adjusting the frequency of oscillation of the quartz crystal tuning fork resonator after the disposing step of the metal or the glass so that the frequency of oscillation thereof is about 32.768 kHz with a frequency deviation within the range of -30 ppm to +30 ppm.

54. A method according to claim 1; wherein the two of the quartz crystal tuning fork tines comprise first and second quartz crystal tuning fork tines, the main surfaces of each of the first and second quartz crystal tuning fork tines comprise a first main surface and a second main surface opposite the first main surface, and each of the first and second quartz crystal tuning fork tines has a first side surface and a second side surface opposite the first side surface; wherein the step of forming the at least one groove comprises forming a groove in each of the first and second main surfaces of each of the first and second quartz crystal tuning fork tines so that a width of the groove formed in each of the first and second main surfaces of each of the first and second quartz crystal tuning fork tines is greater than a distance in the width direction of the groove measured from an outer edge of the groove to an outer edge of the corresponding one of the first and second quartz crystal tuning fork tines; wherein the disposing step comprises forming a first electrode on a surface of the groove formed in each of the first and second main surfaces of each of the first and second quartz crystal tuning fork tines and forming a second electrode on each of the first and second side surfaces of each of the first and second quartz crystal tuning fork tines so that the first electrode formed on the surface of the groove formed in each of the first and second main surfaces of the first quartz crystal tuning fork tine is connected to the second electrode formed on each of the first and second side surfaces of the second quartz crystal tuning fork tine, and the second electrode formed on each of the first and second side surfaces of the first quartz crystal tuning fork tine is connected to the first electrode formed on the surface of the groove formed in each of the first and second main surfaces of the second quartz crystal tuning fork tine; wherein the case has an interior space containing the mounting portion and an open end through which the quartz crystal tuning fork resonator is mounted on the mounting portion; and after the adjusting step, further comprising the step of connecting a lid to the open end of the case to cover the open end of the case.

55. A method according to claim 54; wherein the first side surface of the first quartz crystal tuning fork tine confronts the first side surface of the second quartz crystal tuning fork tine;

wherein the step of forming the at least one groove comprises forming the groove having a first stepped portion including a first width and a second groove portion including a second width different from the first width in at least one of the first and second main surfaces of each of the first and second quartz crystal tuning fork tines so that a first distance in the width direction of the first groove portion measured from a first outer edge of the first groove portion to a first outer edge of the first side surface of the corresponding one of the first and second quartz crystal tuning fork tines is greater than a second distance in the width direction of the second groove portion measured from a second outer edge of the second groove portion to a second outer edge of the first side surface of the corresponding one of the first and second quartz tuning fork tines; wherein the first width of the first groove portion of the groove formed in the at least one of the first and second main surfaces of the first quartz crystal tuning fork tine is greater than the first distance in the width direction of the first groove portion of the first quartz crystal tuning fork tine; wherein the first width of the first groove portion of the groove formed in the at least one of the first and second main surfaces of the second quartz crystal tuning fork tine is greater than the first distance in the width direction of the first groove portion of the second quartz crystal tuning fork tine; wherein the case has a through hole; and further comprising the step of disposing a metal or a glass in the through hole of the case to close the through hole thereof in a vacuum; wherein the lid is a metal lid or a glass lid; and wherein the connecting step comprises the step of connecting the metal lid or the glass lid to the open end of the case.

56. A method according to claim 54; wherein the adjusting step comprises the step of adjusting the frequency of oscillation of the quartz crystal tuning fork resonator so that the frequency of oscillation thereof is about 32.768 kHz with a frequency deviation within the range of -100 ppm to +100 ppm; and wherein the connecting step comprises the step of connecting the lid to the open end of the case so that the interior space of the case is in a vacuum.

57. A method according to claim 54; further comprising the step of adjusting the frequency of oscillation of the quartz crystal tuning fork resonator after the forming step of the first and second electrodes and before the mounting step so that the frequency of oscillation thereof is about 32.768 kHz with a frequency deviation within the range of -9000 ppm to +5000 ppm.

58. A method according to claim 54; wherein the first side surface of the first quartz crystal tuning fork tine confronts the first side surface of the second quartz crystal tuning fork tine; wherein the step of forming the at least one groove includes the step of forming a groove having a first and a second surface connected to the first surface through a third surface in each of the first and second main surfaces of each of the first and second quartz crystal tuning fork tines so that a ratio  $W_2/W$  is in the range of 0.35 to 0.85, where  $W_2$  represents a width of the groove and  $W$  represents a width of each of the first and second quartz crystal tuning fork tines, and so that each of the first and second surfaces of the groove formed in each of the first and second main surfaces of the first quartz crystal tuning fork tine is formed opposite the first side surface of the first quartz tuning fork tine and each of the first and second surfaces of the groove formed in each of the first and second main surfaces of the second quartz crystal tuning fork tine is formed opposite the first side surface of the second quartz crystal tuning fork tine, each of the first, second and third surfaces having a first end and a second end portion, the first end portion of the first surface being directly connected to the first end portion of the third surface and the first end

portion of the second surface being directly connected to the second end portion of the third surface; wherein the groove having the first, second and third surfaces formed in each of the first and second main surfaces of each of the first and second quartz crystal tuning fork tines has a fourth surface directly opposite a fifth surface in the length direction, an end portion of the fourth surface being directly connected to the second end portion of the first surface and an end portion of the fifth surface being directly connected to the second end portion of the second surface.

59. A method according to claim 1; wherein the two of the quartz crystal tuning fork tines comprise first and second quartz crystal tuning fork tines, the main surfaces of each of the first and second quartz crystal tuning fork tines comprise a first main surface and a second main surface opposite the first main surface, and each of the first and second quartz crystal tuning fork tines has a first side surface and a second side surface opposite the first side surface; wherein the step of forming the at least one groove comprises forming at least one groove in each of the first and second main surfaces of each of the first and second quartz crystal tuning fork tines; wherein the step of disposing an electrode comprises the steps of forming a first electrode on a surface of the at least one groove formed in each of the first and second main surfaces of each of the first and second quartz crystal tuning fork tines and forming a second electrode on each of the first and second side surfaces of each of the first and second quartz crystal tuning fork tines; and further comprising the steps of connecting the first electrode formed on the surface of the at least one groove formed in each of the first and second main surfaces of the first quartz crystal tuning fork tine to the second electrode formed on each of the first and second side surfaces of the second quartz crystal tuning fork tine to form a first electrode terminal, and connecting the second electrode formed on each of the first and second side surfaces of the first quartz crystal tuning fork tine to the first electrode formed on the surface of the at least one groove formed in each of the first and second main surfaces of the second quartz crystal tuning fork tine to form a second electrode terminal so that the quartz crystal tuning fork resonator vibrates in a flexural mode of an inverse phase when an alternating current voltage is applied between the first electrode terminal and the second electrode terminal.

60. A method according to claim 59; wherein the step of forming the at least one groove comprises the step of forming the at least one groove in each of the first and second main surfaces of each of the first and second quartz crystal tuning fork tines so that a width of the at least one groove formed in each of the first and second main surfaces of each of the first and second quartz crystal tuning fork tines is greater than a distance in the width direction of the at least one groove measured from an outer edge of the at least one groove to an outer edge of the corresponding one of the first and second quartz crystal tuning fork tines; and wherein the forming step of the at least one groove is performed before the forming step of the second electrode.

61. A method according to claim 60; wherein the case comprises a ceramics case having a through hole and an interior space containing the mounting portion; and further comprising the steps of adjusting in a vacuum the frequency of oscillation of the quartz crystal tuning fork resonator, covering an open end of the ceramics case with a glass lid after the mounting step and before the adjusting step and thereafter disposing a metal or a glass in the through hole of the ceramics case to close the through hole thereof in a vacuum.

62. A method according to claim 61; wherein the adjusting step comprises the step of adjusting in the vacuum the frequency of oscillation of the quartz crystal tuning fork resonator after the connecting step and before the disposing step of the metal or the glass so that the frequency of oscillation thereof is about 32.768 kHz with a frequency deviation within the range of  $-50$  ppm to  $+50$  ppm.

63. A method according to claim 60; wherein the case comprises a ceramics case having a through hole and an interior space containing the mounting portion; and further comprising the steps of covering an open end of the ceramics case with a glass lid after the mounting step, disposing a metal or a glass in the through hole of the ceramics case to close the through hole thereof in a vacuum, and performing the adjusting step after the step of disposing the metal or the glass in the through hole of the ceramics case so that the frequency of oscillation thereof is about 32.768 kHz with a frequency deviation within the range of  $-30$  ppm to  $+30$  ppm.

64. A method according to claim 60; wherein the case comprises a ceramics case having an open end an interior space containing the mounting portion; wherein the adjusting step comprises adjusting the frequency of oscillation of the quartz crystal tuning fork resonator after the mounting step so that the frequency of oscillation thereof is about 32.768 kHz with a frequency deviation within the range of  $-100$  ppm to  $+100$  ppm; and further comprising the step of connecting a metal lid to the ceramics case after the adjusting step to cover the open end thereof so that the interior space is placed in a vacuum.

65. A method according to claim 60; wherein the case comprises a ceramics case having a through hole, an open end, and an interior space containing the mounting portion; wherein the adjusting step comprises adjusting the frequency of oscillation of the quartz crystal tuning fork resonator so that the frequency of oscillation thereof is about 32.768 kHz with a frequency deviation within the range of  $-100$  ppm to  $+100$  ppm; and further comprising the steps of covering the open end of the ceramics case with a metal lid after the adjusting step and thereafter disposing a metal or a glass in the through hole of the ceramics case to close the through hole thereof in a vacuum.

66. A method according to claim 50; wherein the first side surface of the first quartz crystal tuning fork tine confronts the first side surface of the second quartz crystal tuning fork tine; wherein the step of forming the at least one groove comprises the step of forming a groove having a first stepped portion and a second stepped portion connected to the first stepped portion through a third stepped portion in at least one of the first and second main surfaces of each of the first and second quartz crystal tuning fork tines, each of the first and second stepped portions of the groove formed in the at least one of the first and second main surfaces of the first quartz crystal tuning fork tine being formed opposite the first side surface of the first quartz crystal tuning fork tine and being directly connected to the third stepped portion, and each of the first and second stepped portions of the groove formed in the at least one of the first and second main surfaces of the second quartz crystal tuning fork tine being formed opposite the first side surface of the second quartz crystal tuning fork tine and being directly connected to the third stepped portion; wherein the groove formed in the at least one of the first and second main surfaces of each of the first and second quartz crystal tuning fork tines has a length, and a fourth stepped portion directly opposite a fifth stepped portion in the length direction, the fourth stepped portion being directly connected to the first stepped portion and the fifth stepped portion being directly connected to the second stepped portion; wherein the

quartz crystal tuning fork resonator has an overall length; wherein each of the overall length of the quartz crystal tuning fork resonator and the length of the groove formed in the at least one of the first and second main surfaces of each of the first and second quartz crystal tuning fork tines is determined so that a series resistance  $R_1$  of a fundamental mode of vibration of the quartz crystal tuning fork resonator is less than a series resistance  $R_2$  of a second overtone mode of vibration thereof; wherein the adjusting step comprises adjusting the frequency of oscillation of the quartz crystal tuning fork resonator so that the frequency of oscillation thereof is about 32.768 kHz with a frequency deviation within the range of -100 ppm to +100 ppm; wherein the case has a through hole; and further comprising the step of disposing a metal or a glass in the through hole of the case to close the through hole thereof in a vacuum.

67. A method according to claim 59; wherein the quartz crystal wafer has a first surface and a second surface opposite the first surface; and further comprising the sequential steps of forming a plurality of grooves in the first and second surfaces of the quartz crystal wafer; forming the first and second quartz crystal tuning fork tines so that a groove having a first surface opposite the first side surface and a second surface opposite the second side surface is located in each of the first and second main surfaces of each of the first and second quartz crystal tuning fork tines, a width of the groove located in each of the first and second main surfaces of each of the first and second quartz crystal tuning fork tines being greater than a distance in the width direction of the groove measured from an outer edge of the groove to an outer edge of the corresponding one of the first and second quartz crystal tuning fork tines; and wherein the disposing step comprises disposing the electrode on each of the first and second surfaces of the groove located in each of the first and second main surfaces of each of the first and second quartz crystal tuning fork tines so that the electrode formed on each of the first and second surfaces of the groove located in each of the first and second main surfaces of the first quartz crystal tuning fork tine has an electrical polarity opposite to an electrical polarity of the electrode formed on each of the first and second surfaces of the groove located in each of the first and second main surfaces of the second quartz crystal tuning fork tine.

68. A method according to claim 59; wherein the at least one groove formed in each of the first and second main surfaces of each of the first and second quartz crystal tuning fork tines comprises a plurality of grooves formed in at least one of the first and second main surfaces of each of the first and second quartz crystal tuning fork tines, the grooves being divided in the length direction; and further comprising the step of forming simultaneously the first and second quartz crystal tuning fork tines and the grooves formed in the at least one of the first and second main surfaces of each of the first and second quartz crystal tuning fork tines so that a width of at least one of the grooves formed in the at least one of the first and second main surfaces of each of the first and second quartz crystal tuning fork tines is greater than a distance in the width direction of the at least one groove measured from an outer edge of the at least one groove to an outer edge of the corresponding one of the first and second quartz crystal tuning fork tines.

69. A method according to claim 59; wherein the quartz crystal wafer has a first surface and a second surface opposite the first surface; wherein the quartz crystal tuning fork base has a third main surface and a fourth main surface opposite the third main surface, each of the third main surface of the quartz crystal tuning fork base and the first main surface of each of the first and second quartz crystal tuning fork tines

being formed at the first surface of the quartz crystal wafer, and each of the fourth main surface of the quartz crystal tuning fork base and the second main surface of each of the first and second quartz crystal tuning fork tines being formed at the second surface of the quartz crystal wafer; wherein each of the third and fourth main surfaces of the quartz crystal tuning fork base has a third electrode and a fourth electrode, the third electrode having an electrical polarity opposite to an electrical polarity of the fourth electrode; wherein the third electrode formed on each of the third and fourth main surfaces of the quartz crystal tuning fork base is connected to the second electrode formed on each of the first and second side surfaces of one of the first and second quartz crystal tuning fork tines; wherein the fourth electrode formed on each of the third and fourth main surfaces of the quartz crystal tuning fork base is connected to the second electrode formed on each of the first and second side surfaces of the other of the first and second quartz crystal tuning fork tines; wherein the first electrode formed on the surface of the at least one groove formed in one of the first and second main surfaces of the first quartz crystal tuning fork tine is connected to the second electrode formed on each of the first and second side surfaces of the second quartz crystal tuning fork tine through one of the third and fourth electrodes formed on one of the third and fourth main surfaces of the quartz crystal tuning fork base; and wherein the third electrode formed on the third main surface of the quartz crystal tuning fork base is formed opposite the third electrode formed on the fourth main surface thereof, the third electrode formed on the third main surface of the quartz crystal tuning fork base having the same electrical polarity as the third electrode formed on the fourth main surface of the quartz crystal tuning fork base.

70. A method according to claim 1; wherein the two quartz crystal tuning fork tines comprise first and second quartz crystal tuning fork tines, the main surfaces of each of the first and second quartz crystal tuning fork tines comprising a first main surface and a second main surface opposite the first main surface, and each of the first and second quartz crystal tuning fork tines having a first side surface and a second side surface opposite the first side surface; wherein the quartz crystal wafer has a first surface and a second surface opposite the first surface; further comprising the step of providing a lid for covering an open end of the case, one of the lid and the case having a through hole and the case having an interior space containing the mounting portion; and further comprising the sequential steps of disposing at least one first metal film on each of the first and second surfaces of the quartz crystal wafer; disposing a first resist on the at least one first metal film; removing a part of each of the first resist and the at least one first metal film to form a pattern of a tuning fork shape; forming the quartz crystal tuning fork base, and the first and second quartz crystal tuning fork tines; forming a groove in each of the first and second main surfaces of each of the first and second quartz crystal tuning fork tines so that a width of the groove formed in each of the first and second main surfaces of each of the first and second quartz crystal tuning fork tines is greater than a distance in the width direction of the groove measured from an outer edge of the groove to an outer edge of the corresponding one of the first and second quartz crystal tuning fork tines; disposing at least one second metal film on each of the first and second main surfaces and the first and second side surfaces of each of the first and second quartz crystal tuning fork tines, and a surface of the groove formed in each of the first and second main surfaces of each of the first and second quartz crystal tuning fork tines; disposing a second resist on the at least one second metal film; forming a first electrode on the surface of the

groove formed in each of the first and second main surfaces of each of the first and second quartz crystal tuning fork tines and a second electrode on each of the first and second side surfaces of each of the first and second quartz crystal tuning fork tines so that the first electrode formed on the surface of the groove formed in each of the first and second main surfaces of the first quartz crystal tuning fork tine is connected to the second electrode formed on each of the first and second side surfaces of the second quartz crystal tuning fork tine, and the second electrode formed on each of the first and second side surfaces of the first quartz crystal tuning fork tine is connected to the first electrode formed on the surface of the groove formed in each of the first and second main surfaces of the second quartz crystal tuning fork tine; mounting the quartz crystal tuning fork resonator on the mounting portion in the interior space of the case; connecting the lid to the case to cover the open end thereof; and disposing a metal or a glass in the through hole to close the through hole in a vacuum after the connecting step of the lid and the case.

71. A method according to claim 70; wherein the first side surface of the first quartz crystal tuning fork tine confronts the first side surface of the second quartz crystal tuning fork tine; wherein the forming step of the groove includes the step of forming the groove having a first stepped portion, a second stepped portion, and a third stepped portion connecting the first stepped portion to the second stepped portion in at least one of the first and second main surfaces of each of the first and second quartz crystal tuning fork tines, each of the first and second stepped portions of the groove formed in the at least one of the first and second main surfaces of the first quartz crystal tuning fork tine being formed opposite the first side surface of the first quartz crystal tuning fork tine and being directly connected to the third stepped portion, and each of the first and second stepped portions of the groove formed in the at least one of the first and second main surfaces of the second quartz crystal tuning fork tine being formed opposite the first side surface of the second quartz crystal tuning fork tine and being directly connected to the third stepped portion; and wherein the groove having the first, second and third stepped portions formed in the at least one of the first and second main surfaces of each of the first and second quartz crystal tuning fork tines has a fourth stepped portion directly opposite a fifth stepped portion in the length direction, the fourth stepped portion being directly connected to the first stepped portion and the fifth stepped portion being directly connected to the second stepped portion.

72. A method according to claim 70; wherein the quartz crystal tuning fork resonator has an overall length and the groove formed in each of the first and second main surfaces of each of the first and second quartz crystal tuning fork tines has a length; and further comprising the step of determining the overall length of the quartz crystal tuning fork resonator and the length of the groove formed in each of the first and second main surfaces of each of the first and second quartz crystal tuning fork tines before the disposing step of the at least one first metal film so that a series resistance  $R_1$  of a fundamental mode of vibration of the quartz crystal tuning fork resonator is less than a series resistance  $R_2$  of a second overtone mode of vibration thereof.

73. A method according to claim 70; further comprising the steps of adjusting the frequency of oscillation of the quartz crystal tuning fork resonator to a first preselected frequency of oscillation after the forming step of the first and second electrodes and before the mounting step; and adjusting the frequency of oscillation of the quartz crystal tuning fork reso-

erator to a second preselected frequency of oscillation after the mounting step and before the connecting step of the lid and the case.

74. A method according to claim 73; wherein the first preselected frequency of oscillation is about 32.768 kHz with a frequency deviation in the range of  $-9000$  ppm to  $+5000$  ppm; and wherein the second frequency of oscillation is about 32.768 kHz with a frequency deviation within the range of  $-100$  ppm to  $+100$  ppm.

75. A method according to claim 70; further comprising the step of adjusting in a vacuum the frequency of oscillation of the quartz crystal tuning fork resonator after the connecting step of the lid and the case and before the disposing step of the metal or the glass.

76. A method according to claim 70; further comprising the step of adjusting the frequency of oscillation of the quartz crystal tuning fork resonator after the disposing step of the metal or the glass so that the frequency of oscillation thereof is about 32.768 kHz with a frequency deviation within the range of  $-30$  ppm to  $+30$  ppm.

77. A method according to claim 70; wherein the first electrode formed on the surface of the groove formed in each of the first and second main surfaces of each of the first and second quartz crystal tuning fork tines extends on a surface in the width direction adjoining the groove; wherein the groove formed in each of the first and second main surfaces of each of the first and second quartz crystal tuning fork tines has a first surface and a second surface, the first surface having a first outer edge and the second surface having a second outer edge; wherein the first surface of the groove formed in each of the first and second main surfaces of each of the first and second quartz crystal tuning fork tines is opposite the first side surface of the corresponding one of the first and second quartz crystal tuning fork tines; wherein the second surface of the groove formed in each of the first and second main surfaces of each of the first and second quartz crystal tuning fork tines is opposite the second side surface of the corresponding one of the first and second quartz crystal tuning fork tines; wherein each of the first and second side surfaces of each of the first and second quartz crystal tuning fork tines has a first outer edge and a second outer edge, a distance in the width direction of the groove measured from the first outer edge of the first surface of the groove to the first outer edge of the first side surface of the corresponding one of the first and second quartz crystal tuning fork tines being defined by  $W_1$  and a distance in the width direction of the groove measured from the second outer edge of the second surface of the groove to the second outer edge of the second side surface of the corresponding one of the first and second quartz crystal tuning fork tines being defined by  $W_3$ ; wherein the first main surface of each of the first and second quartz crystal tuning fork tines is formed at the first surface of the quartz crystal wafer; and further comprising the step of forming the groove in the first main surface of each of the first and second quartz crystal tuning fork tines so that  $W_1$  is greater than  $W_3$ .

78. A method according to claim 70; further comprising the step of removing all of each of the first resist disposed on the at least one first metal film and the at least one first metal film before the disposing step of the at least one second metal film.

79. A method according to claim 70; wherein the first side surface of the first quartz crystal tuning fork tine confronts the first side surface of the second quartz crystal tuning fork tine; wherein the step of forming the groove comprises forming a groove having a first groove portion including a first width and a second groove portion including a second width different from the first width in at least one of the first and second main surfaces of each of the first and second quartz crystal



tuning fork tines so that a first distance in the width direction of the first groove portion measured from a first outer edge of the first groove portion to a first outer edge of the first side surface of the corresponding one of the first and second quartz crystal tuning fork tines is greater than a second distance in the width direction of the second groove portion measured from a second outer edge of the second groove portion to a second outer edge of the first side surface of the corresponding one of the first and second quartz crystal tuning fork tines; wherein the first width of the first groove portion of the groove formed in the at least one of the first and second main surfaces of the first quartz crystal tuning fork tine is greater than the first distance in the width direction of the first groove portion of the first quartz crystal tuning fork tine; and wherein the first width of the first groove portion of the groove formed in the at least one of the first and second main surfaces of the second quartz crystal tuning fork tine is greater than the first distance in the width direction of the first groove portion of the second quartz crystal tuning fork tine.

80. A method according to claim 1; wherein the quartz crystal tuning fork tines has first and second quartz crystal tuning fork tines, each of the first and second quartz crystal tuning fork tines having a first main surface and a second main surface opposite the first main surface, and a first side surface and a second side surface opposite the first side surface; wherein the quartz crystal wafer has a first surface and a second surface opposite the first surface; and further comprising the sequential steps of disposing at least one first metal film on each of the first and second surfaces of the quartz crystal wafer; disposing a first resist on the at least one first metal film; removing a part of each of the first resist and the at least one first metal film to form a pattern of a tuning fork shape; forming the quartz crystal tuning fork base, and the first and second quartz crystal tuning fork tines; forming a groove in each of the first and second main surfaces of each of the first and second quartz crystal tuning fork tines so that a width of the groove formed in each of the first and second main surfaces of each of the first and second quartz crystal tuning fork tines is greater than a distance in the width direction of the groove measured from an outer edge of the groove to an outer edge of the corresponding one of the first and second quartz crystal tuning fork tines; disposing at least one second metal film on each of the first and second main surfaces and the first and second side surfaces of each of the first and second quartz crystal tuning fork tines, and a surface of the groove formed in each of the first and second main surfaces of each of the first and second quartz crystal tuning fork tines; disposing a second resist on the at least one second metal film; forming a first electrode on the surface of the groove formed in each of the first and second main surfaces of each of the first and second quartz crystal tuning fork tines and a second electrode on each of the first and second side surfaces of each of the first and second quartz crystal tuning fork tines so that the first electrode formed on the surface of the groove formed in each of the first and second main surfaces of the first quartz crystal tuning fork tine is connected to the second electrode formed on each of the first and second side surfaces of the second quartz crystal tuning fork tine, and the second electrode formed on each of the first and second side surfaces of the first quartz crystal tuning fork tine is connected to the first electrode formed on the surface of the groove formed in each of the first and second main surfaces of the second quartz crystal tuning fork tine; mounting the quartz crystal tuning fork resonator on the mounting portion of the case; adjusting the frequency of oscillation of the quartz crystal tuning fork resonator; and connecting a lid to the case after the adjusting step.

81. A method according to claim 80; wherein the forming step of the groove includes the step of forming the groove in each of the first and second main surfaces of each of the first and second quartz crystal tuning fork tines so that a ratio  $W_2/W$  is in the range of 0.35 to 0.85, where  $W_2$  represents a width of the groove and  $W$  represents a width of each of the first and second quartz crystal tuning fork tines; wherein the adjusting step includes the step of adjusting the frequency of oscillation of the quartz crystal tuning fork resonator so that the frequency of oscillation thereof is about 32.768 kHz with a frequency deviation within the range of  $-100$  ppm to  $+100$  ppm; wherein the connecting step of the lid and the case includes the step of connecting the lid to the case in a vacuum; and further comprising the step of adjusting the frequency of oscillation of the quartz crystal tuning fork resonator after the forming step of the first and second electrodes and before the mounting step so that the frequency of oscillation thereof is about 32.768 kHz with a frequency deviation within the range of  $-9000$  ppm to  $+5000$  ppm.

82. A method according to claim 1; wherein the two quartz crystal tuning fork tines comprise first and second quartz crystal tuning fork tines, each of the first and second quartz crystal tuning fork tines having a first main surface and a second main surface opposite the first main surface, and a first side surface and a second side surface opposite the first side surface, the first side surface of the first quartz crystal tuning fork tine confronting the first side surface of the second quartz crystal tuning fork tine; wherein the step of forming the at least one groove includes the step of forming a groove having at least two surfaces in each of the first and second main surfaces of each of the first and second quartz crystal tuning fork tines; and further comprising the sequential steps of forming the quartz crystal tuning fork base and the first and second quartz crystal tuning fork tines; and forming the groove having the at least two surfaces with a first surface opposite the first side surface and a second surface opposite the second side surface in each of the first and second main surfaces of each of the first and second quartz crystal tuning fork tines so that a width of the groove formed in each of the first and second main surfaces of each of the first and second quartz crystal tuning fork tines is greater than a distance in the width direction of the groove measured from an outer edge of the groove to an outer edge of the corresponding one of the first and second quartz crystal tuning fork tines, a first electrode being formed on each of the first and second surfaces of the groove formed in each of the first and second main surfaces of each of the first and second quartz crystal tuning fork tines; wherein the quartz crystal tuning fork resonator has an overall length and the groove formed in each of the first and second main surfaces of each of the first and second quartz crystal tuning fork tines has a length; and further comprising the step of determining the overall length of the quartz crystal tuning fork resonator and the length of the groove formed in each of the first and second main surfaces of each of the first and second quartz crystal tuning fork tines so that a series resistance  $R_1$  of a fundamental mode of vibration of the quartz crystal tuning fork resonator is less than a series resistance  $R_2$  of a second overtone mode of vibration thereof.

83. A method according to claim 82; wherein the quartz crystal tuning fork resonator has the series resistance  $R_1$  of the fundamental mode of vibration less than the series resistance  $R_2$  of the second overtone mode of vibration; wherein the forming step of the groove includes the step of forming the groove having a first stepped portion, a second stepped portion and a third stepped portion connecting the first stepped portion to the second stepped portion in at least one of the first and second main surfaces of each of the first and second

45

quartz crystal tuning fork tines, each of the first and second stepped portions of the groove formed in the at least one of the first and second main surfaces of the first quartz crystal tuning fork tine being formed opposite the first side surface of the first quartz crystal tuning fork tine, and being directly 5 connected to the third stepped portion, and each of the first and second stepped portions of the groove formed in the at least one of the first and second main surfaces of the second quartz crystal tuning fork tine being formed opposite the first side surface of the second quartz crystal tuning fork tine and 10 being directly connected to the third stepped portion; and wherein the groove having the first, second and third stepped portions formed in the at least one of the first and second main surfaces of each of the first and second quartz crystal tuning fork tines has a fourth stepped portion directly opposite a fifth 15 stepped portion in the length direction, the fourth stepped portion being directly connected to the first stepped portion and the fifth stepped portion being directly connected to the second stepped portion.

84. A method according to claim 1; wherein the two quartz 20 crystal tuning fork tines comprise first and second quartz crystal tuning fork tines, each of the first and second quartz crystal tuning fork tines having a first main surface and a second main surface opposite the first main surface, and a first side surface and a second side surface opposite the first 25 side surface, the first side surface of the first quartz crystal tuning fork tine confronting the first side surface of the second

46

quartz crystal tuning fork tine; wherein the step of forming the at least one groove comprises forming a groove having a first groove portion including a first width and a second groove portion including a second width different from the first width in at least one of the first and second main surfaces of each of the first and second quartz crystal tuning fork tines so that a first distance in the width direction of the first groove portion measured from a first outer edge of the first groove portion to a first outer edge of the first side surface of the corresponding one of the first and second quartz crystal tuning fork tines is greater than a second distance in the width direction of the second groove portion measured from a second outer edge of the second groove portion to a second outer edge of the first side surface of the corresponding one of the first and second quartz crystal tuning fork tines; wherein the first width of the first groove portion of the groove formed in the at least one of the first and second main surfaces of the first quartz crystal tuning fork tine is greater than the first distance in the width direction of the first groove portion of the first quartz crystal tuning fork tine; and wherein the first width of the first groove portion of the groove formed in the at least one of the first and second main surfaces of the second quartz crystal tuning fork tine is greater than the first distance in the width direction of the first groove portion of the second quartz crystal tuning fork tine.

\* \* \* \* \*