



US00RE44356E

(19) **United States**
(12) **Reissued Patent**
Choi et al.

(10) **Patent Number:** **US RE44,356 E**
(45) **Date of Reissued Patent:** **Jul. 9, 2013**

(54) **TUNABLE-WAVELENGTH OPTICAL FILTER AND METHOD OF MANUFACTURING THE SAME**

(75) Inventors: **Chang Auck Choi**, Daejeon-shi (KR); **Myung Lae Lee**, Daejeon (KR); **Chang Kyu Kim**, Daejeon (KR); **Chi Hoon Jun**, Daejeon (KR); **Youn Tae Kim**, Daejeon (KR)

(73) Assignee: **Electronics and Telecommunications Research Institute**, Daejeon (KR)

(21) Appl. No.: **12/828,908**

(22) Filed: **Jul. 1, 2010**

Related U.S. Patent Documents

Reissue of:

(64) Patent No.: **7,393,793**
Issued: **Jul. 1, 2008**
Appl. No.: **11/508,017**
Filed: **Aug. 21, 2006**

U.S. Applications:

(62) Division of application No. 11/045,554, filed on Jan. 27, 2005, now Pat. No. 7,012,752, which is a division of application No. 10/671,825, filed on Sep. 25, 2003, now Pat. No. 7,163,872.

(30) **Foreign Application Priority Data**

Dec. 10, 2002 (KR) 2002-78443

(51) **Int. Cl.**
H01L 21/302 (2006.01)
B29D 11/00 (2006.01)

(52) **U.S. Cl.**
USPC **438/723**; 438/700; 438/455; 359/223;
359/230; 216/2; 216/24; 216/67; 216/74;
216/79; 385/14; 385/18

(58) **Field of Classification Search**
USPC 438/455, 700, 702, 706, 719, 723; 216/2,
216/24, 67, 74, 79, 80; 359/223, 224, 230;
385/14, 18

See application file for complete search history.

(56) **References Cited**

U.S. PATENT DOCUMENTS

5,561,523 A * 10/1996 Blomberg et al. 356/454
5,909,280 A * 6/1999 Zavracky 356/454
6,304,689 B1 * 10/2001 Dingel et al. 385/24

(Continued)

OTHER PUBLICATIONS

J. Peerlings, et al., "Long Resonator Micromachined Tunable GaAs-AlAx Fabry-Perot Filter", IEEE Photonics Technology Letters, vol. 9, No. 9, Sep. 1997.*

Primary Examiner — Shamim Ahmed
(74) *Attorney, Agent, or Firm* — NSIP Law

(57) **ABSTRACT**

A method of manufacturing a tunable wavelength optical filter. The method includes steps of forming a first sacrificial oxide film for floating a lower mirror on a semiconductor substrate; sequentially laminating conductive silicon films and oxide films for defining a mirror region on the first sacrificial oxide film in a multi-layer and laminating another conductive silicon film to form a lower mirror; sequentially laminating conductive silicon films and oxide films for defining the mirror region on a second sacrificial oxide film in a multi-layer and laminating another conductive silicon film to form an upper mirror and forming an optical tuning space between the lower mirror and the upper mirror and etching the first sacrificial oxide film and the second sacrificial oxide film such that the lower mirror is floated on the semiconductor substrate.

14 Claims, 7 Drawing Sheets

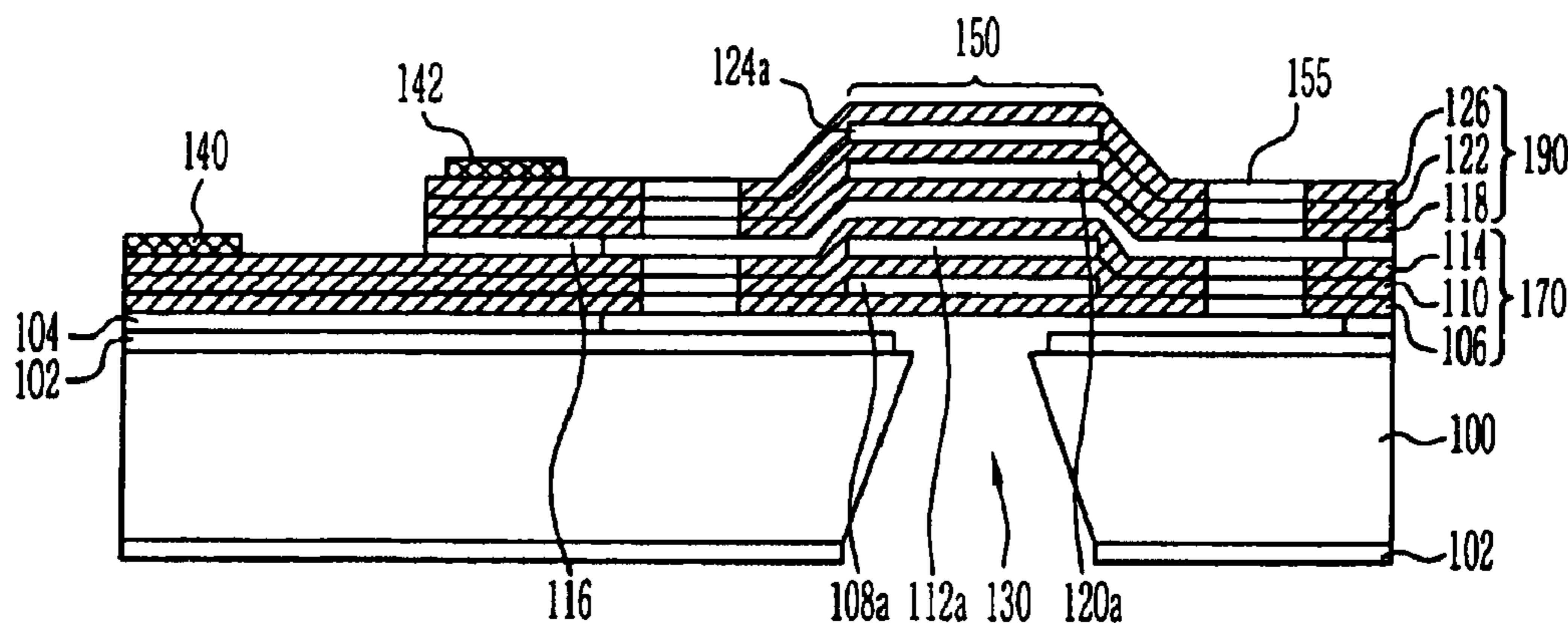

US RE44,356 E

Page 2

U.S. PATENT DOCUMENTS

6,341,039	B1 *	1/2002	Flanders et al.	359/578	6,822,779	B2	11/2004	Chi	
6,351,577	B1 *	2/2002	Aksyuk et al.	385/15	6,950,570	B1	9/2005	Novotny	
6,373,632	B1 *	4/2002	Flanders	359/578	7,034,975	B1 *	4/2006	Islam et al.	359/223
6,381,022	B1 *	4/2002	Zavracky	356/454	7,071,566	B2 *	7/2006	Cole et al.	257/777
6,449,403	B1 *	9/2002	Cush et al.	385/15	2002/0031155	A1 *	3/2002	Tayebati et al.	372/50
6,487,230	B1 *	11/2002	Boucart et al.	372/96	2002/0126725	A1 *	9/2002	Tayebati	372/96
6,525,880	B2 *	2/2003	Flanders et al.	359/578	2002/0168136	A1 *	11/2002	Atia et al.	385/18
6,594,059	B2 *	7/2003	Flanders	359/230	2003/0012231	A1 *	1/2003	Tayebati et al.	372/20
6,661,830	B1 *	12/2003	Reed et al.	372/99	2003/0020926	A1 *	1/2003	Miron	356/519
6,665,459	B2 *	12/2003	Cush et al.	385/15	2003/0169786	A1 *	9/2003	Kapon et al.	372/20
6,724,785	B1 *	4/2004	Tucker et al.	372/20	2003/0174952	A1	9/2003	Fan	
6,813,053	B1 *	11/2004	Chase et al.	359/224.1	2005/0052746	A1	3/2005	Shih et al.	

* cited by examiner

FIG. 1

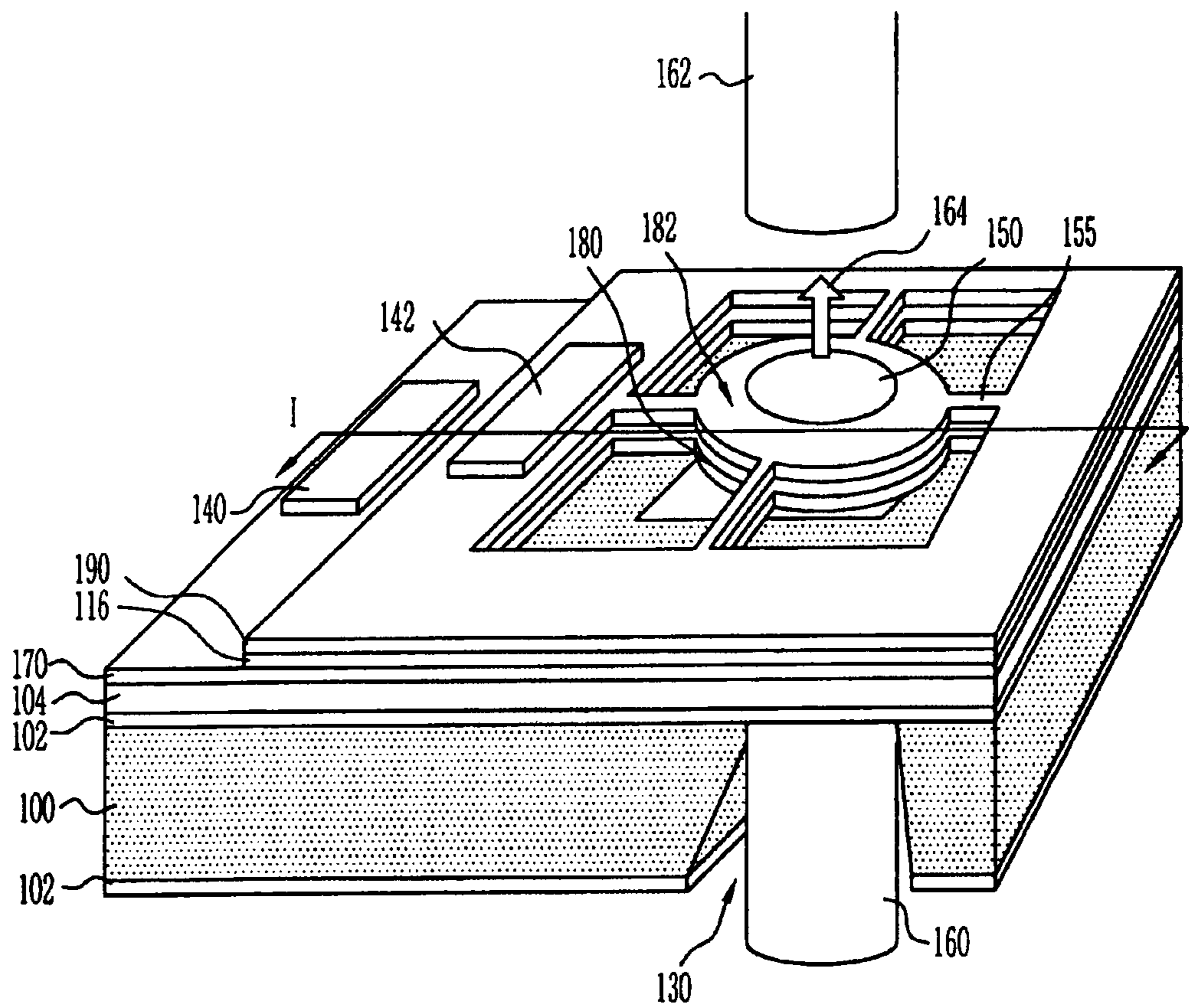

FIG. 2

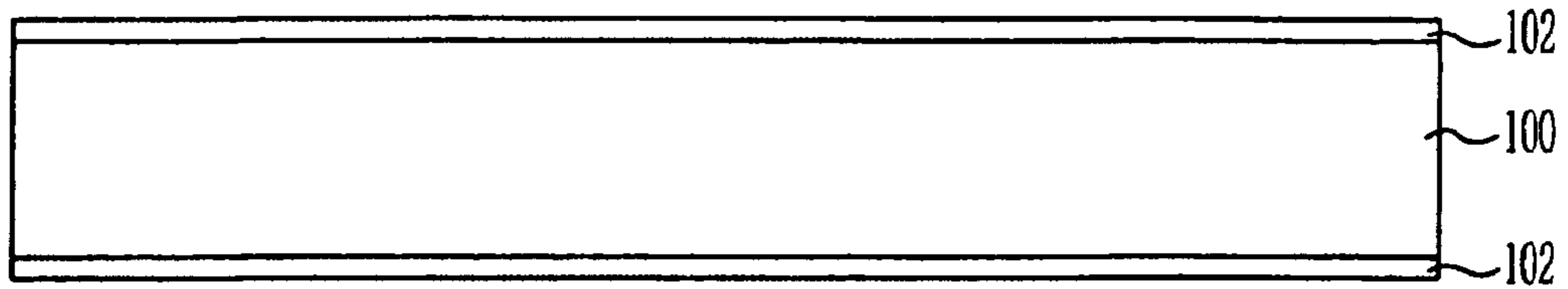

FIG. 3

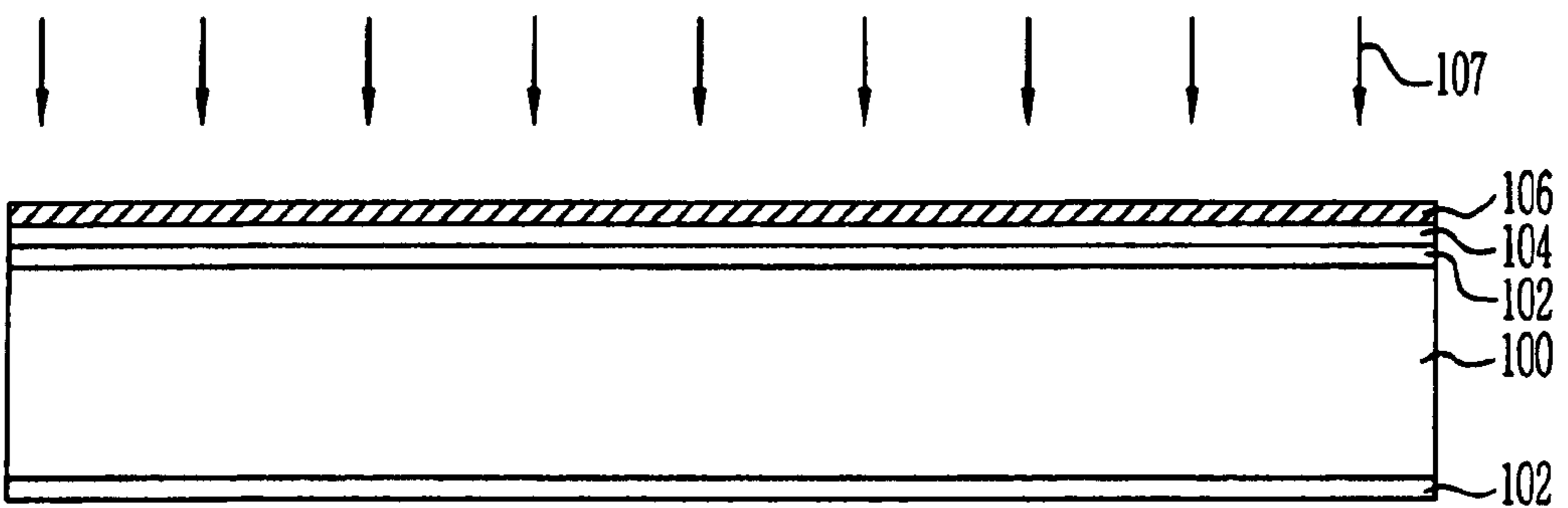

FIG. 4

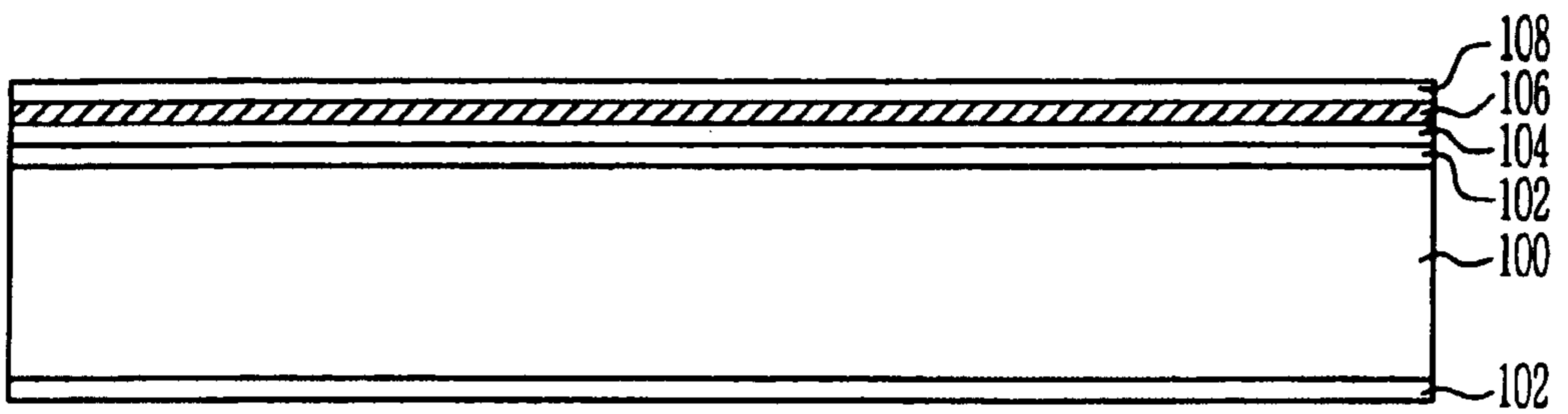

FIG. 5

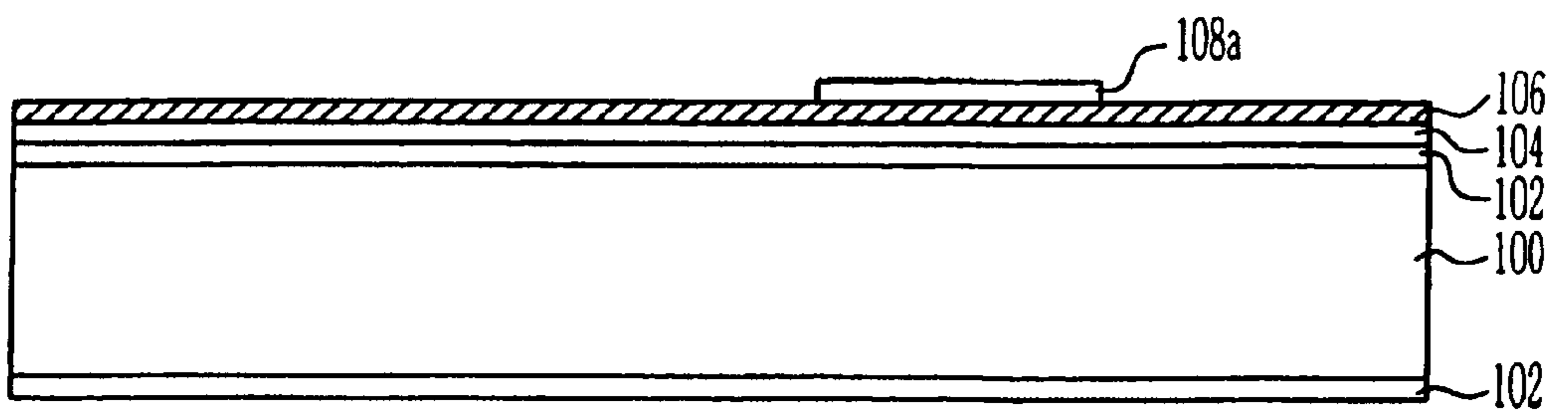

FIG. 6

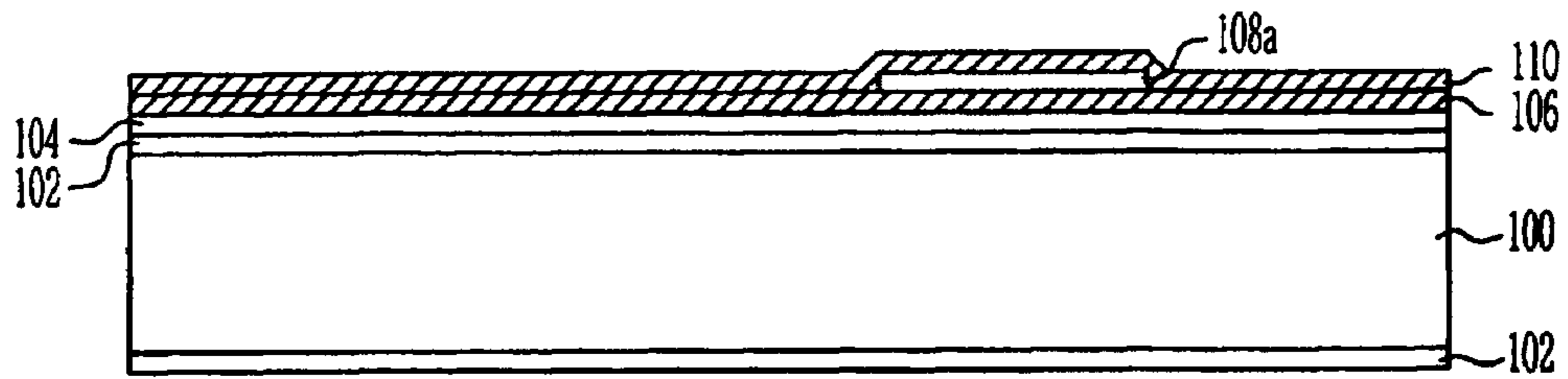

FIG. 7

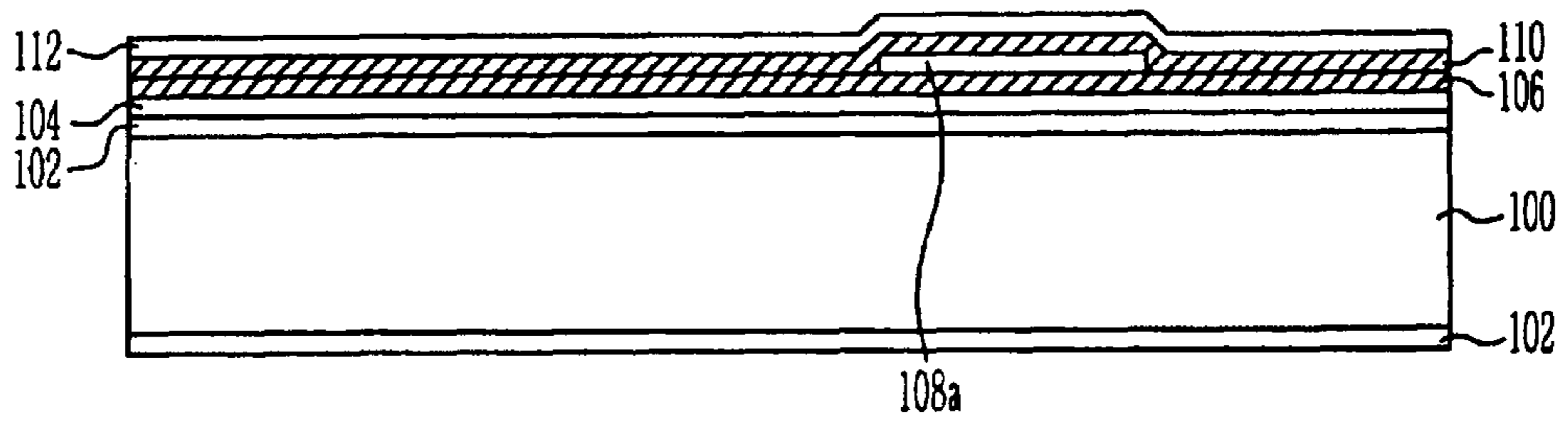

FIG. 8

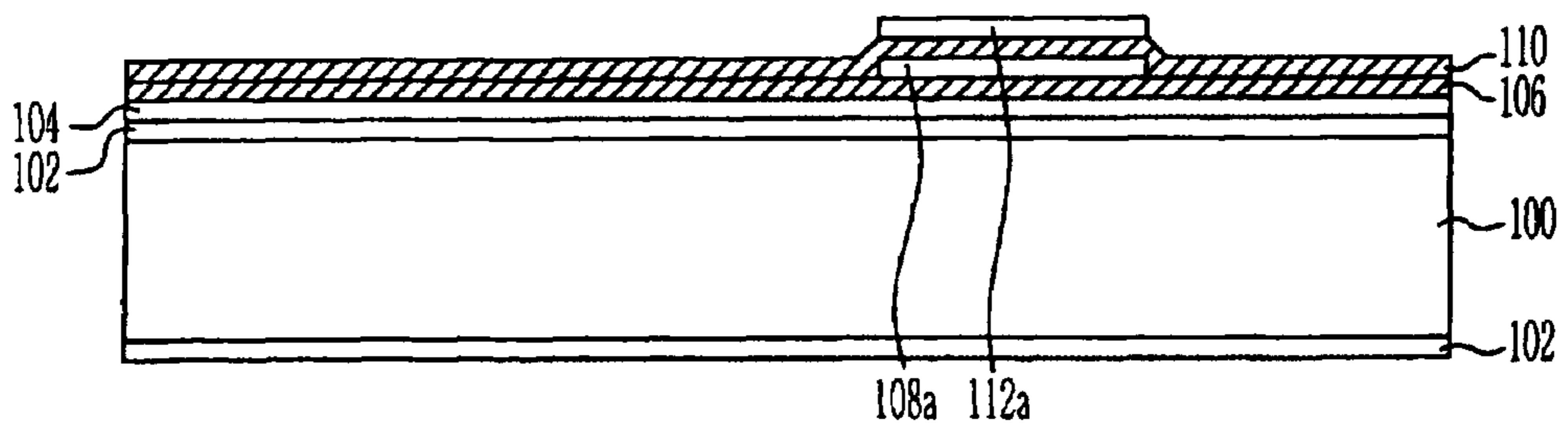

FIG. 9

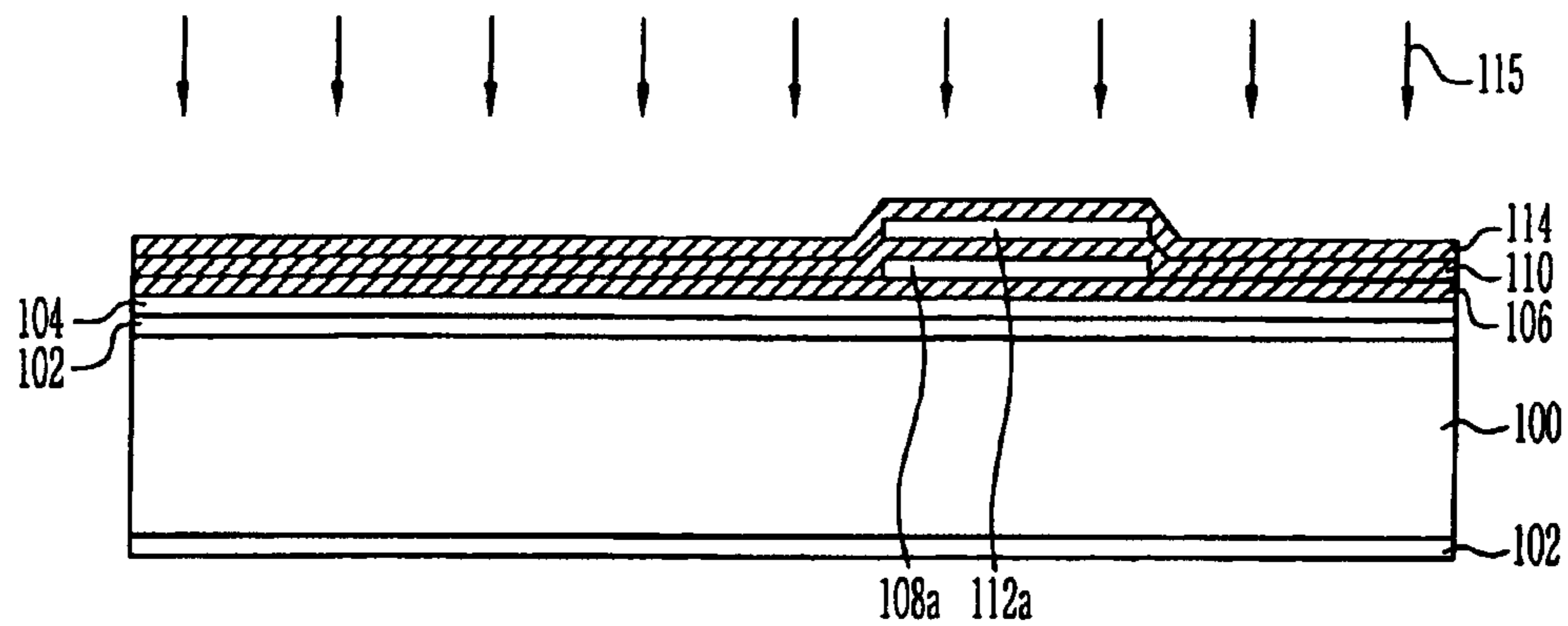

FIG. 10

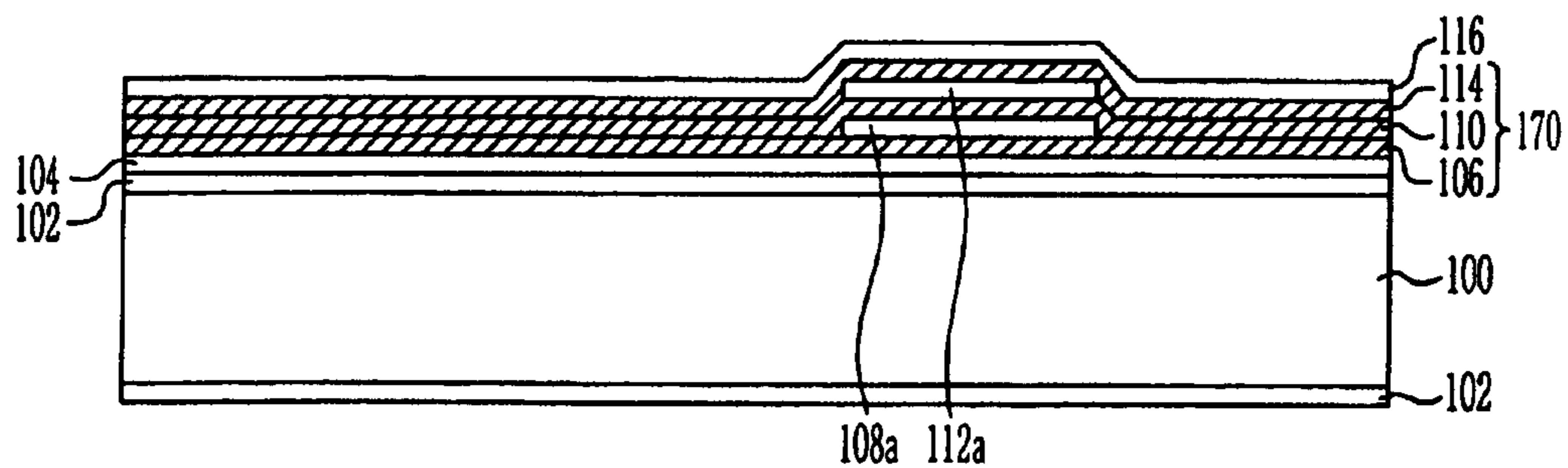

FIG. 11

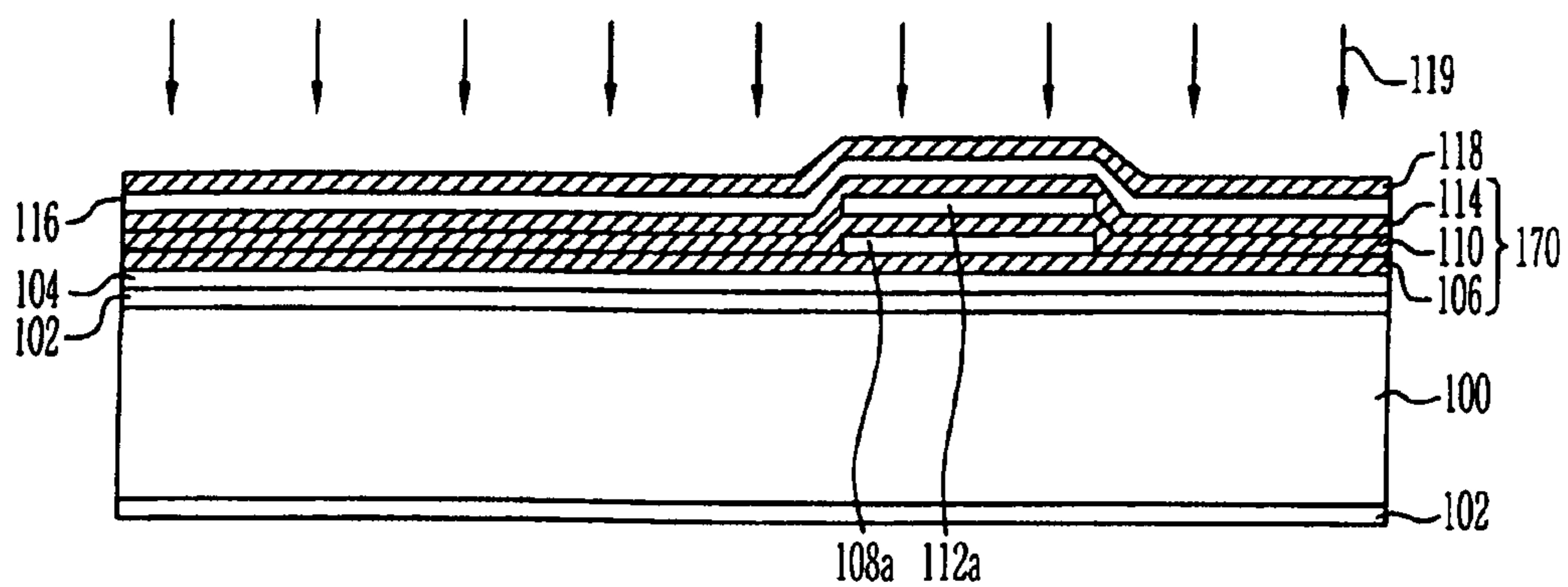

FIG. 12

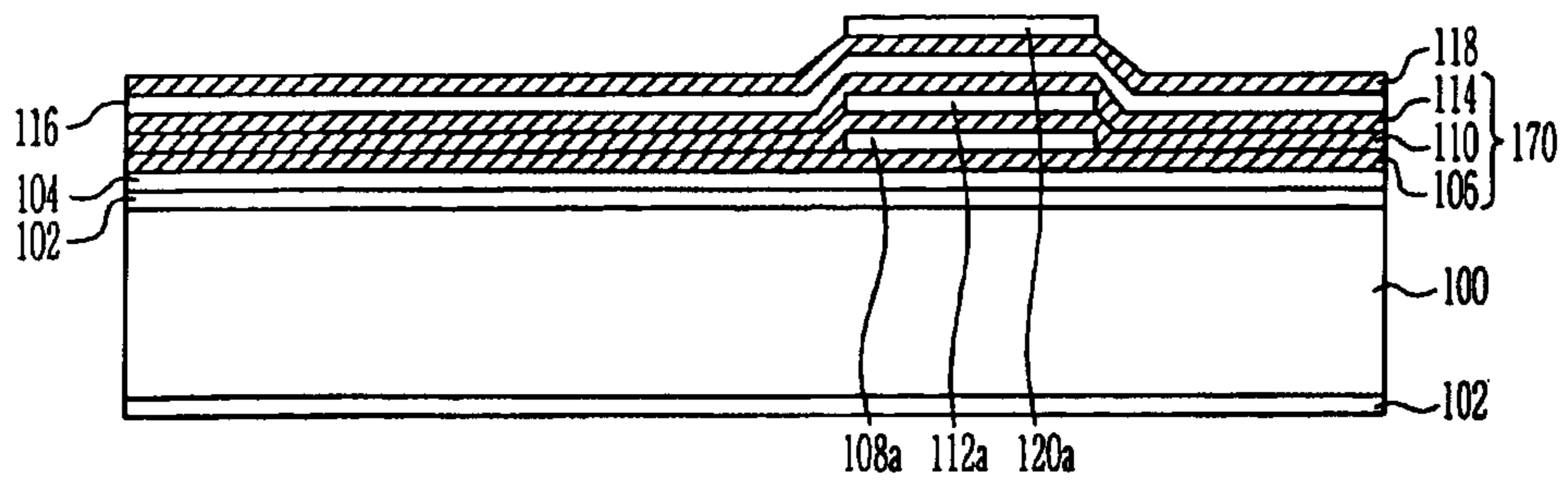

FIG. 13

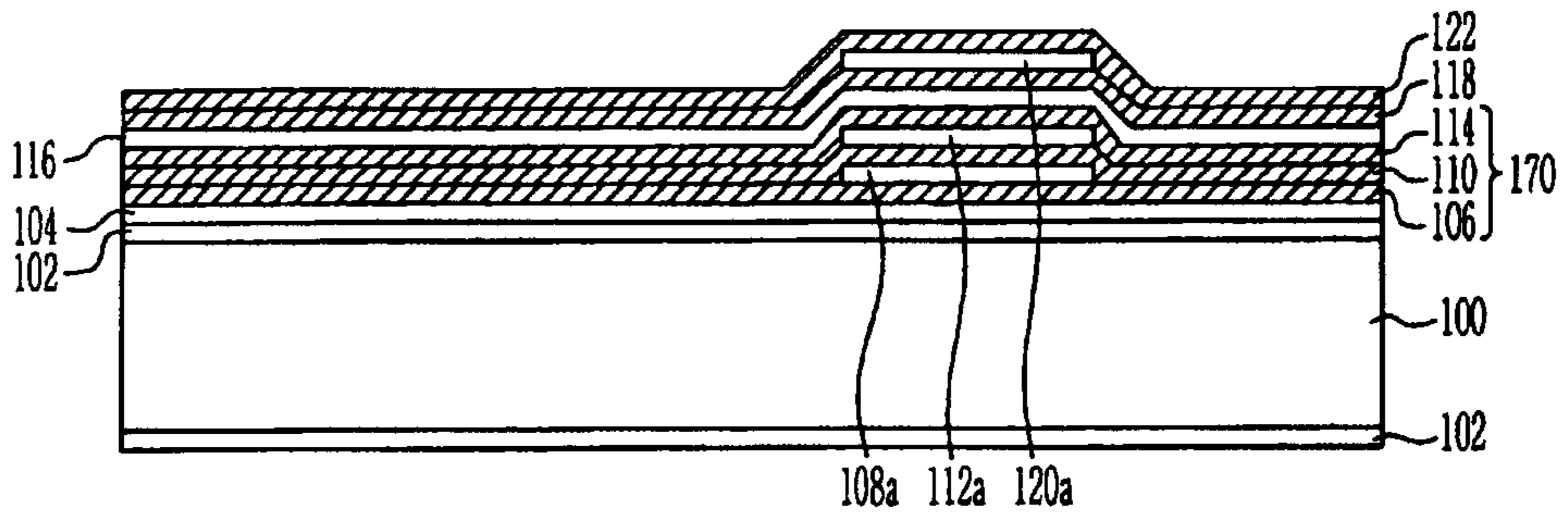
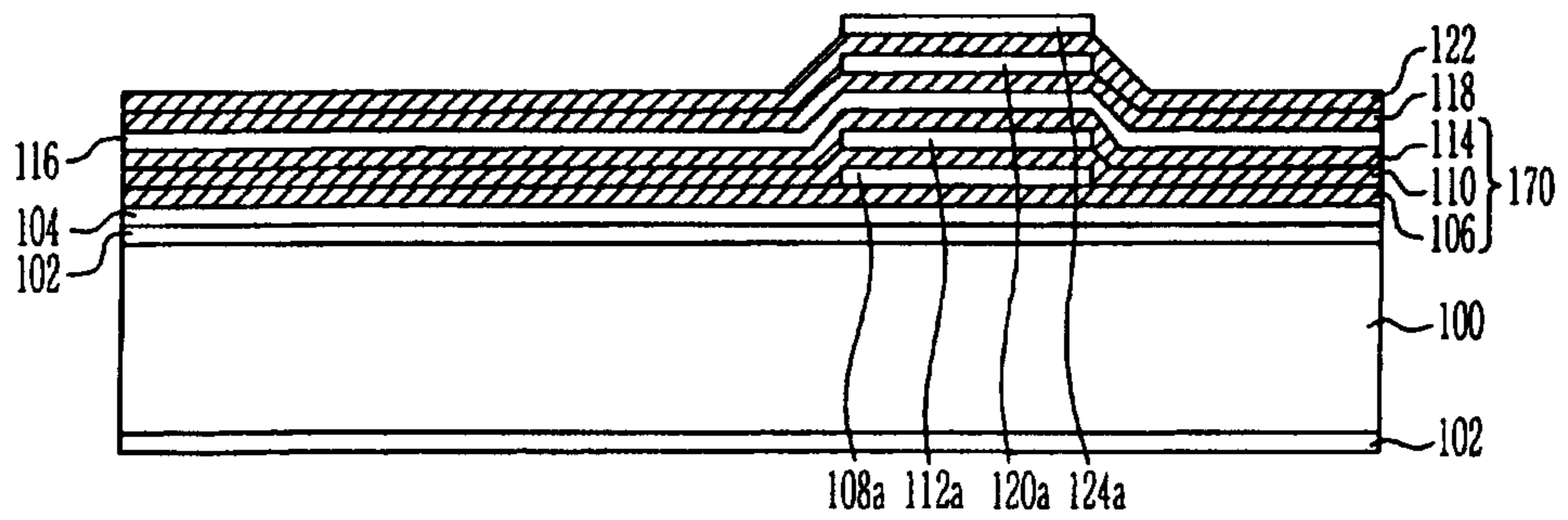

FIG. 14



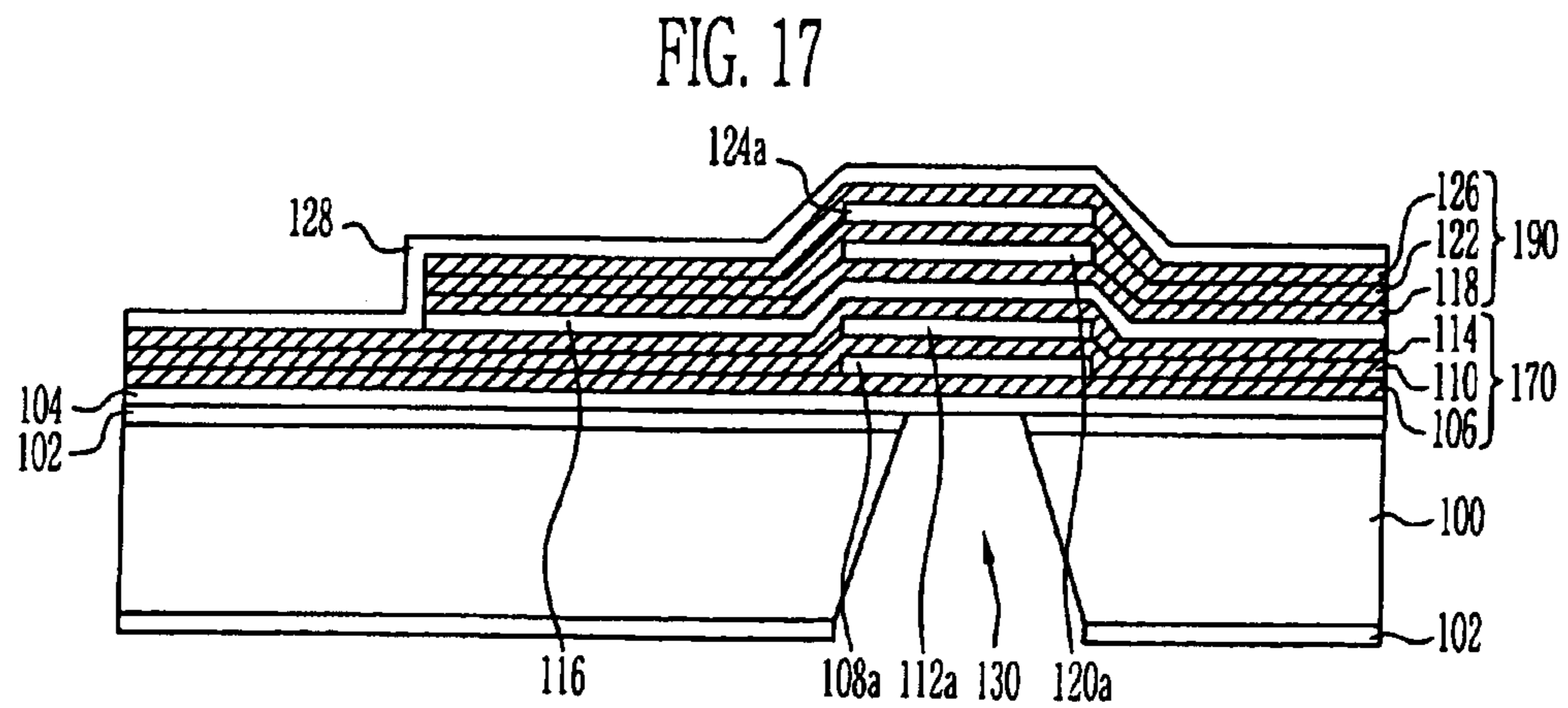
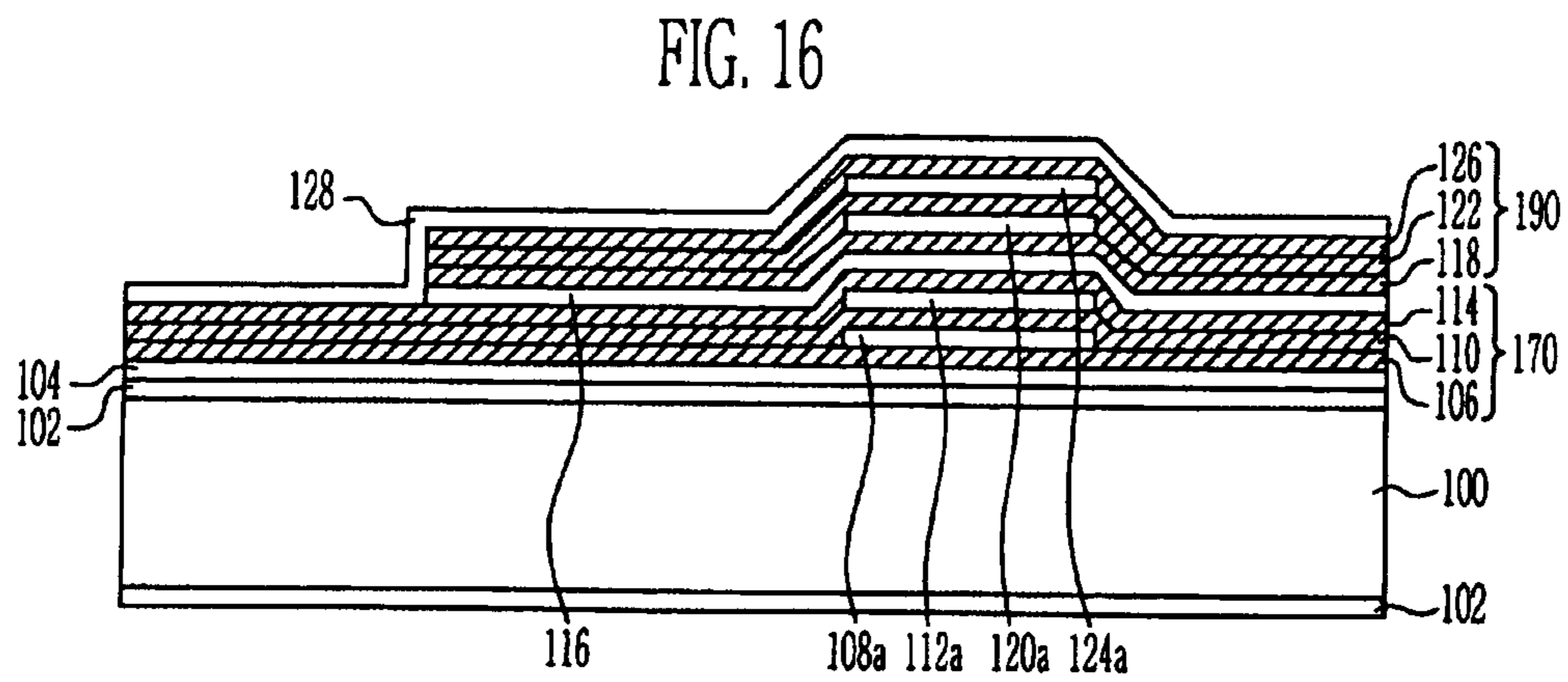
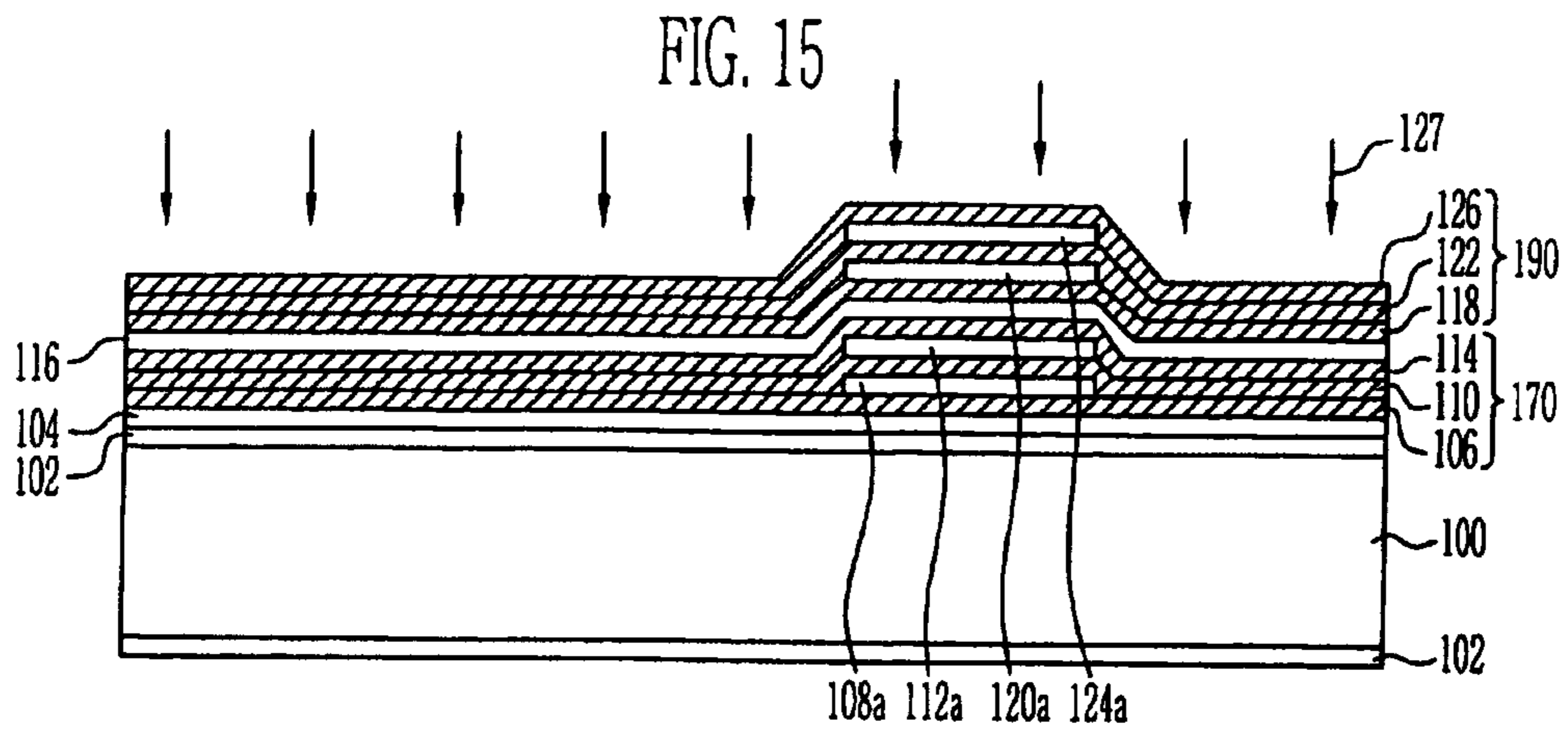

FIG. 18

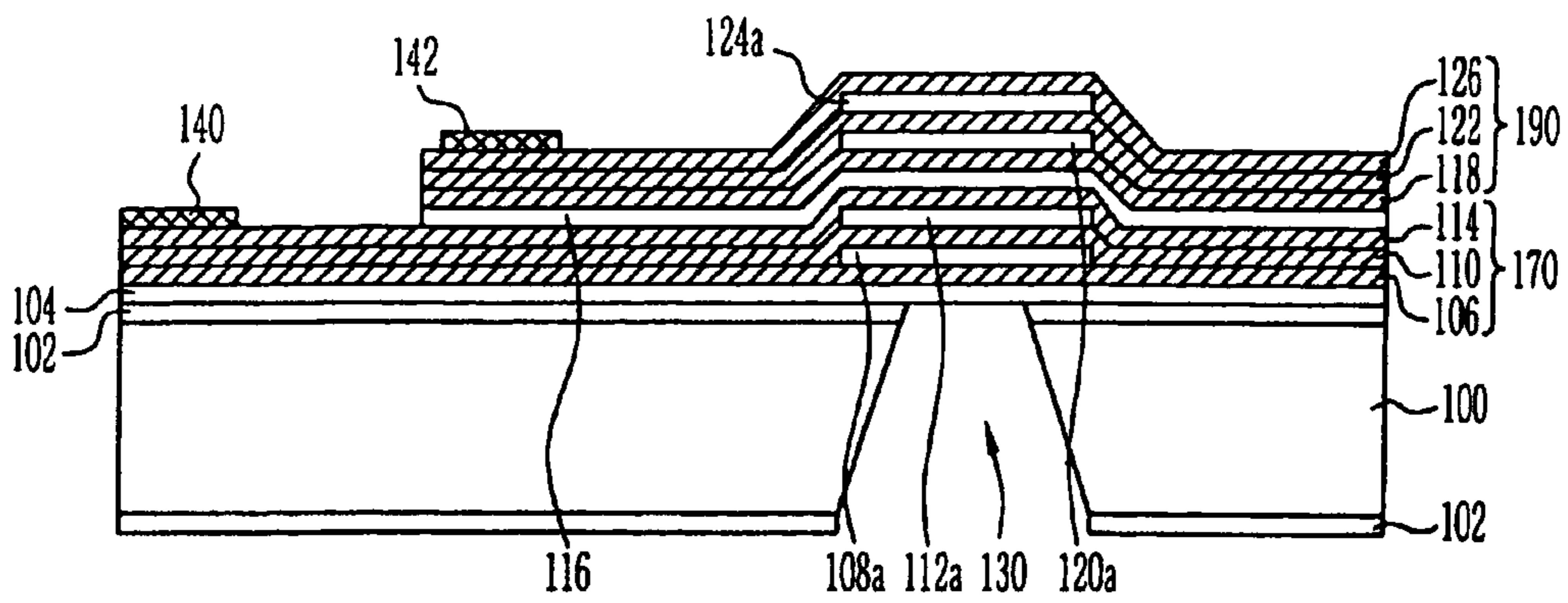
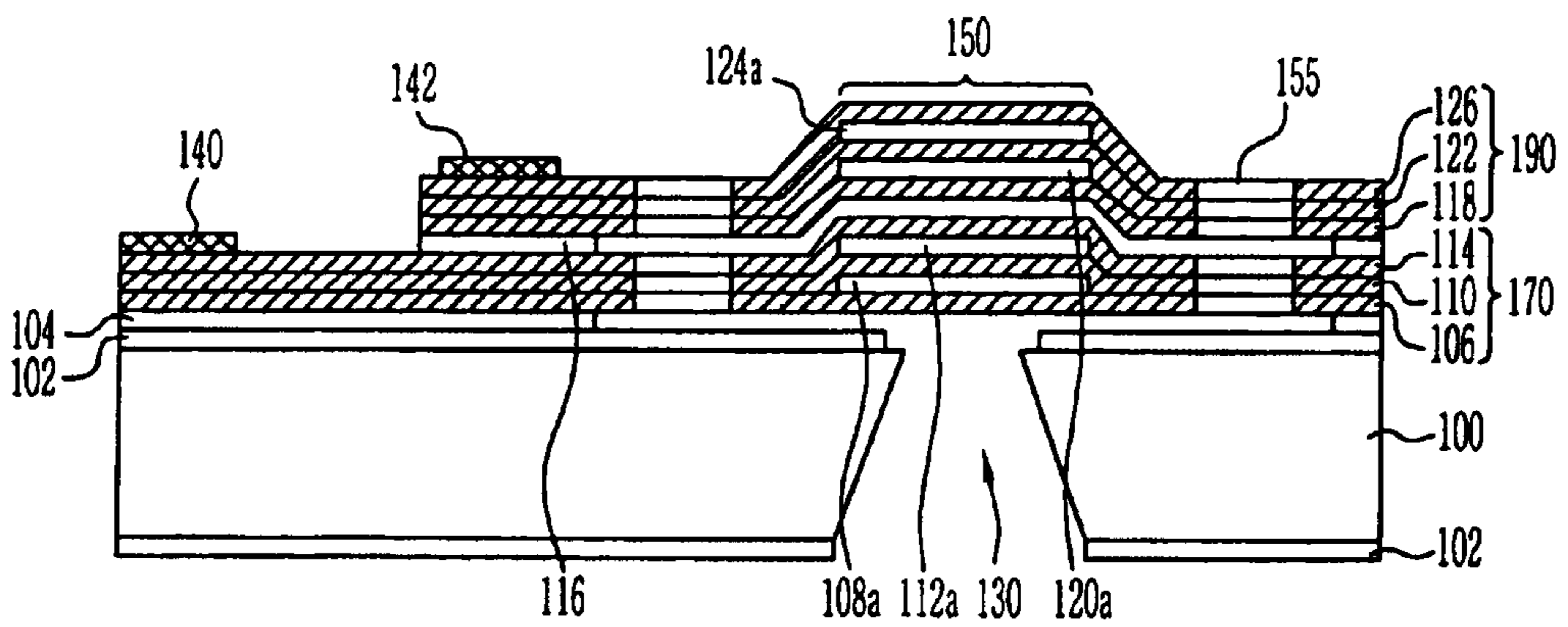

FIG. 19



**TUNABLE-WAVELENGTH OPTICAL FILTER
AND METHOD OF MANUFACTURING THE
SAME**

Matter enclosed in heavy brackets [] appears in the original patent but forms no part of this reissue specification; matter printed in italics indicates the additions made by reissue.

*CROSS REFERENCE TO RELATED PATENT
APPLICATIONS*

[This application] *This present patent application is a Reissue of U.S. Pat. No. 7,393,793, issued on Jul. 1, 2008, which is a division of U.S. application Ser. No. 11/045,554 filed on Jan. 27, 2005, now U.S. Pat. No. 7,012,752, which is a division of U.S. application Ser. No. 10/671,825 filed on Sep. 25, 2003, now U.S. Pat. No. 7,163,872.*

BACKGROUND OF THE INVENTION

1. Field of the Invention

The present invention relates to a tunable wavelength optical filter, more particularly, to an active type tunable wavelength optical filter having a Fabry-Perot structure.

2. Description of the Prior Art

Among micro electromechanical systems (MEMS) based on a semiconductor process technique, an active type optical filter for wavelength division multiplexing (WDM) is applied to an optical communication. Recently, it is used in an optical signal dividing and multiplexing device for a massive information network such as Internet. Such optical filter has a function of dividing an input signal, which is in an optical wavelength multiplexing transmitting method, into output signals by the wavelength region. Particularly, in order to implement a dynamic WDM system, it is a key to manufacture the active type tunable wavelength optical filter operated at a high speed. Various techniques of manufacturing the tunable wavelength filter for implementing the dynamic WDM system were suggested. But, among them, in case of a piezo-electric transducer filter of adjusting a gap between two pairs of Fabry-Perot micro-mirrors by a piezo material, it has a limitation in the application thereof, because of the physical instability of a used material and a slow response characteristics. In addition, a Mach-Zender optical filter using an optical interference phenomenon is accomplished by manufacturing an optical waveguide and a phase modulator on a semiconductor substrate, but has a problem that the structure thereof is complicated and it is difficult to manufacture that. In order to improve the previous method of manufacturing the filter, the active type tunable wavelength filter having the MEMS structure of which the response speed is relatively quick and the manufacture technique is easy as the semiconductor process technique has been suggested.

On the other hand, in a piezo-type FP filter or a tunable filter having a Fiber Bragg Grating carved in an optical fiber, which is currently commercial, since a tuning speed is slow at the level of msec or the tunable wavelength band is narrow, it is impossible to use that to the active type network device. However, the MEMS type tunable filter using an electrostatic force as a driving source accomplishes the response speed below few tens microsecond (μ s) and the tunable wavelength band of the order of 100 nm, thereby it can be applied to the current optical communication system. However, the MEMS type tunable filter of gallium-arsenide substrate suggested currently has problems that a consistent process can not be

performed like the silicon wafer process due to difficulties of the manufacturing process and the packaging technique.

SUMMARY OF THE INVENTION

5

Thus, the object of the present invention is to provide an active type tunable wavelength optical filter having a Fabry-Perot structure which uses a mirror having a high reflexivity and having a multi-layer structure of silicon films and oxide films.

10

The other object of the present invention is to provide an active type tunable wavelength optical filter having a Fabry-Perot structure which a silicon semiconductor process technique is used, the process thereof is simple, and it is possible to the mass production.

15

In order to solve the above-mentioned problems, according to an aspect of the present invention, a tunable wavelength optical filter comprising a lower mirror in which silicon films and oxide films are sequentially laminated in a multi-layer and the silicon film is laminated on the highest portion; an upper mirror in which silicon films and oxide films are sequentially laminated in a multi-layer and the silicon film is laminated on the highest portion and which is spaced away from the lower mirror by a predetermined distance; a connecting means for connecting and supporting the lower mirror and the upper mirror to a semiconductor substrate; and electrode pads for controlling the gap between the lower mirror and the upper mirror by an electrostatic force is provided.

20

25

30

35

40

45

50

55

60

65

70

75

80

85

90

95

100

105

110

115

120

125

130

135

140

145

150

155

160

165

170

175

180

185

190

195

200

205

210

215

220

225

230

235

240

245

250

255

260

265

270

275

280

285

290

295

300

305

310

315

320

325

330

335

340

345

350

355

360

365

370

375

380

According to the other aspect of the present invention, a method of manufacturing a tunable wavelength optical filter which comprises the steps of (a) forming a first sacrificial oxide film for floating a lower mirror on a semiconductor substrate; (b) sequentially laminating conductive silicon films and oxide films for defining a mirror region on the first sacrificial oxide film in a multi-layer and laminating another conductive silicon film to form a lower mirror; (c) forming a second sacrificial film on the resultant; (d) sequentially laminating conductive silicon films and oxide films for defining the mirror region on the second sacrificial oxide film in a multi-layer and laminating another conductive silicon film to form an upper mirror; (e) etching the rear side of the semiconductor substrate to form an opening for inserting an optical fiber thereinto; (f) forming electrode pads for controlling the gap between the lower mirror and the upper mirror by an electrostatic force; (g) etching the silicon film around the upper mirror in a dry etching method to expose the second sacrificial oxide film, such that the upper mirror is suspended by a connecting means; and (h) forming an optical tuning space between the lower mirror and the upper mirror and etching the first sacrificial oxide film and the second sacrificial oxide film such that the lower mirror is floated on the semiconductor substrate is provided.

According to the further other aspect of the present invention, a method of manufacturing a tunable wavelength optical filter which comprises the steps of (a) forming a sacrificial oxide film for floating a mirror on a semiconductor substrate; (b) sequentially laminating conductive silicon films and oxide films for defining a mirror region on the sacrificial oxide film in a multi-layer and laminating another conductive silicon film to form a mirror; (c) etching the rear side of the semiconductor substrate to form an opening for inserting an optical fiber thereinto; (d) forming electrode pads for controlling the gap between the mirrors by an electrostatic force; (e) etching the silicon film around the mirror in a dry etching method to expose the sacrificial oxide film, such that the mirror is suspended by a connecting means; and (f) etching the sacrificial oxide film such that the mirror is floated on the

semiconductor substrate, wherein two semiconductor substrate formed by the steps (a) to (f) are prepared and are attached to each other through a spacer layer therebetween so that the mirrors of the semiconductor substrates are opposite to each other is provided.

BRIEF DESCRIPTION OF THE ATTACHED DRAWINGS

FIG. 1 shows an active type tunable wavelength optical filter having a Fabry-Perot structure according to a preferred embodiment of the present invention.

FIGS. 2 to 19 are cross sectional views illustrating a method of manufacturing the active type tunable wavelength optical filter having the Fabry-Perot structure.

DESCRIPTION OF THE PREFERRED EMBODIMENT

Hereinafter, the preferred embodiments of the present invention will be explained with reference to the accompanying drawings. However, the embodiment of the present invention can be changed into a various type, and it should be not understood that the scope of the present invention is limit to the following embodiments. The embodiments of the present invention are provided in order to explain the present invention to those skilled in the art. When describing that a certain layer is laid on the other layer in the below-mentioned explanation, the certain layer may be laid just on the other layer or may be laid on the other layer sandwiching a third layer. In addition, in the drawings, the thickness or the size of each layer is exaggerated for the convenience and the clearness of the explanation. In the drawings, a same reference numeral indicates a same element.

FIG. 1 shows an active type tunable wavelength optical filter having a Fabry-Perot structure according to a preferred embodiment of the present invention.

Referring to FIG. 1, the active type tunable wavelength optical filter having a Fabry-Perot structure according to the preferred embodiment of the present invention, comprises a lower mirror 180 in which silicon films and silicon oxide films are sequentially laminated in a multi-layer shape and the silicon film is laminated in the highest portion, an upper mirror 182 which is spaced away from the lower mirror 180 by a predetermined distance in which silicon films and silicon oxide films are sequentially laminated in a multi-layer shape and the silicon film is laminated in the highest portion, a connecting means 155 for connecting and supporting the lower mirror 180 and the upper mirror 182 to a semiconductor substrate 100, and electrode pads 140, 142 for controlling the gap between the lower mirror 180 and the upper mirror 182 by an electrostatic force.

The lower mirror 180 is spaced away from the semiconductor substrate 100 by a predetermined distance and is floated on the semiconductor substrate, and an opening 130 for inserting an optical fiber thereinto is provided on the rear side of the semiconductor substrate 100 corresponding to the mirror region 150.

The electrode pads 140, 142 are electrically connected with the silicon film of the highest film in the lower mirror 180 and the silicon film of the highest film in the upper mirror 182, respectively.

It is preferable that the lower mirror 180 and the upper mirror 182 are symmetrical to each other and have a circular plate shaped structure.

A sacrificial oxide film 104 is provided between the semiconductor substrate 100 and a lower silicon film 170 around

the lower mirror 180 and the upper mirror 182, and the peripheral region of the lower and upper mirrors is opened so as to expose the semiconductor substrate 100.

Hereinafter, this will be further explained. The two spaced flat mirrors 180, 182 are suspended by a torsion bar or a spring 155 and comprise the lower mirror 180 and the upper mirror 182 having the structure of laminating the silicon film/silicon oxide film. The two mirrors 180, 182 have a function of finely adjusting the spaced distance by an electrostatic force due to the voltage applied to the electrode pads 140, 142 formed on the lower silicon film 170 and the upper silicon film 190 each having the structure of laminating the silicon. A first sacrificial oxide film 104 for floating the two mirrors 180, 182 from the surface of the semiconductor substrate 100 is provided between the semiconductor substrate 100 and the lower silicon film 170. Also, a second sacrificial film 116 for adjusting the gap between the mirrors deposited for forming an optical tuning space of the two mirrors is provided between the lower silicon film 170 and the upper silicon film 190. Signal light having a multi-wavelength, which is output from the optical fiber 160 inserted into an opening 130 in the rear side of the semiconductor substrate 100, is transmitted to a transmitting optical fiber 162 after filtering the wavelength of transmitting light by adjusting the micro-distance between the two spaced mirrors 180, 182 when passing through the two mirrors 180, 182.

FIGS. 2 to 19 are cross sectional views illustrating a method of manufacturing the active type tunable wavelength optical filter having the Fabry-Perot structure. FIGS. 2 to 19 are cross sectional views along to the line I-I' in FIG. 1.

Referring to FIG. 2, thermal oxide films 102 are grown on the both polished sides of a semiconductor substrate 100 by a thermal oxide process. The thermal oxide film 102 is grown so as to have a thickness of 6000 Å. The thermal oxide 102 may be formed at a temperature of 950-1100° C. in the oxygen atmosphere. The semiconductor substrate 100 has a thickness of 350-400 μm. The semiconductor substrate 100 may be a silicon substrate or a quartz substrate.

Referring to FIG. 3, a sacrificial oxide film 104 is formed on any one surface of the semiconductor substrate 100 on which the thermal oxide films 102 are formed. It is preferable that the first sacrificial oxide film 104 has a thickness of 2-3 μm. The first sacrificial oxide film 104 may be formed by a PECVD (Plasma Enhanced Chemical Vapor Deposition) method, at a pressure of 1.5 Torr and a temperature of 300° C. in the atmosphere of mixing SiH₄ gas of 15 sccm, N₂O gas of 1000 sccm, and N₂ gas of 600 sccm.

Subsequently, a first silicon film 106 of single crystal or polycrystal is deposited on the sacrificial oxide film 104. It is preferable that the first silicon film 106 is deposited so as to have a predetermined thickness, for example, a thickness of $d=(2m+1)\lambda/4n$ ($m=0, 1, 2, \dots$). Here, d is the deposited thickness, λ is the wavelength of the light source, and n is an optical refractive index of the deposited thin film (silicon film). The first silicon film 106 may be formed by a LPCVD (Low Pressure Chemical Vapor Deposition) method using SiH₄ gas of 140-200 sccm, at a pressure of 280 mTorr and a temperature of 625° C. Next, for electrical connection, a process of doping POCl₃ or a process of injecting ions such as phosphorus 107 into the laminated first silicon film 106 is performed.

Referring to FIG. 4, a silicon oxide film 108 is deposited on the first silicon film 106. The first silicon oxide film 108 is to form the lower mirror 180 having the laminated structure of the silicon film and the silicon oxide film. It is preferable that the first silicon oxide film 108 is deposited so as to have a predetermined thickness, for example, a thickness of $d=(2m+$

5

$1)\lambda/4n(m=0, 1, 2, \dots)$. Here, d is the deposited thickness, λ is the wavelength of the light source, and n is an optical reflectivity of the deposited thin film (silicon oxide film). The first silicon oxide film **108** may be formed by a LPCVD (Low Pressure Chemical Vapor Deposition) method using TEOS (Tetra Ethyl Ortho Silicate) of 200 sccm, at a pressure of 350 mTorr and a temperature of 710-720° C.

Referring to FIG. 5, the first silicon oxide film **108** is patterned to form a first silicon oxide film pattern **108a**. The first silicon oxide film pattern **108a** defines a mirror region **150**. For example, in case where the mirror region (See '150' in FIG. 1) has a circular plate shaped structure, the first silicon oxide film pattern **108a** has the circular plate shaped structure, similar to the mirror region **150**.

Referring to FIG. 6, a second silicon film **110** having a predetermined thickness is deposited on the semiconductor substrate **100** on which the first silicon oxide film pattern **108a** is formed. It is preferable that the second silicon film **110** is deposited so as to have a predetermined thickness, for example, a thickness of $d=(2m+1)\lambda/4n(m=0, 1, 2, \dots)$. Here, d is the deposited thickness, λ is the wavelength of the light source, and n is an optical refractive index of the deposited thin film (the second silicon film). The second silicon film **110** may be formed by a LPCVD (Low Pressure Chemical Vapor Deposition) method using SiH_4 gas of 140-200 sccm, at a pressure of 280 mTorr and a temperature of 625° C.

Referring to FIG. 7, a second silicon oxide film **112** having a predetermined thickness is deposited on the second silicon film **110**. It is preferable that the second silicon oxide film **112** is deposited so as to have a predetermined thickness, for example, a thickness of $d=(2m+1)\lambda/4n(m=0, 1, 2, \dots)$. Here, d is the deposited thickness, λ is the wavelength of the light source, and n is an optical refractive index of the deposited thin film (silicon oxide film). The second silicon oxide film **112** may be formed by the same method as the method of forming the first silicon oxide film **108**.

Referring to FIG. 8, the second silicon oxide film **112** is patterned to form a second silicon oxide film pattern **112a**. The second silicon oxide film pattern **112a** defines the mirror region. For example, in case where the mirror region (See '150' in FIG. 1) has a circular plate shaped structure, the second silicon oxide film pattern **112a** has a circular plate shaped structure, similar to the mirror region **150**.

Referring to FIG. 9, a third silicon film **114** is deposited on the semiconductor substrate **100** on which the second silicon oxide film pattern **112a** is formed. Subsequently, for electrical connection, a process of doping POCl_3 or a process of injecting ions such as phosphorus **115** into the laminated silicon film **114** is performed.

On the other hand, in order to increase the optical reflectivity of the lower mirror **180** having the laminated structure of the silicon film and the silicon oxide film, if necessary, before the third silicon film **114** is formed, the silicon film and the silicon oxide film may be further laminated as need by the same method as the above-mentioned method.

Referring to FIG. 10, in order to form the optical tuning space between the lower mirror **180** and the upper mirror **182**, a second sacrificial oxide film **116** is deposited by the thickness of the tuning space. It is preferable that the second sacrificial oxide film **116** is formed by a thickness capable of adjusting the spaced distance between the upper mirror **182** and the lower mirror **180** by the electrostatic force due to the applied voltage, for example, 2-3 μm . The second sacrificial oxide film may be formed by a PECVD (Plasma Enhanced Chemical Vapor Deposition) method using SiH_4 gas of 60 sccm and N_2O gas of 1000 sccm, at a pressure of 3 Torr and a temperature of 300° C.

6

Subsequently, an upper mirror **182** having a laminated structure symmetrical to the lower mirror **180** is formed on the second sacrificial oxide film **116**. Hereinafter, the steps of forming the upper mirror **182** will be explained.

Referring to FIG. 11, first, a fourth silicon film **118** is deposited, and, for electrical connection, a process of doping POCl_3 or a process of injecting ions such as phosphorus **119** into the laminated fourth silicon film **118** is performed. It is preferable that the fourth silicon film **118** is formed by a same thickness and a same method as the first silicon film **106** in the lower mirror **180**.

Referring to FIG. 12, a fourth silicon oxide film is deposited on the fourth silicon film **118**, and then is patterned to form the fourth silicon oxide film pattern **120a**. It is preferable that the fourth silicon oxide film is formed by a same thickness and a same method as the first silicon oxide film **108** in the lower mirror **180**. The fourth silicon oxide film pattern **120a** defines the mirror region (See '150' in FIG. 1).

Referring to FIG. 13, a fifth silicon film **122** is deposited on the semiconductor substrate **100** on which the fourth silicon oxide film pattern **120a** is formed. It is preferable that the fifth silicon film **122** is formed by a same thickness and a same method as the second silicon film **110** in the lower mirror **180**.

Referring to FIG. 14, a fifth silicon oxide film is deposited on the fifth silicon film **122**, and then is patterned to form the fifth silicon oxide film pattern **124a**. It is preferable that the fifth silicon oxide film is formed by a same thickness as the second silicon oxide film **112**. The fifth silicon oxide film pattern **124a** defines the mirror region (See '150' in FIG. 1).

Referring to FIG. 15, a sixth silicon film **126** is deposited on the semiconductor substrate **100** on which the fifth silicon oxide film pattern **124a** is performed, and a process of doping POCl_3 or a process of injecting ions such as phosphorus **127** thereinto is performed. It is preferable that the sixth silicon film **126** is formed by a same thickness and a same method as the third silicon film **114** of the lower mirror **180**.

On the other hand, in order to increase the optical reflectivity of the upper mirror **182** having the laminated structure of the silicon film and the silicon oxide film, if necessary, before the sixth silicon film **126** is formed, the silicon film and the silicon oxide film may be further laminated as need by the same method as the above-mentioned method.

Referring to FIG. 16, in order to form an electrode pad (See '140' in FIG. 1) electrically connected with the third silicon film **114** in the lower mirror **180**, the silicon films **126**, **122**, **118** forming the upper mirror **182** and the second sacrificial oxide film **116** are etched by a plasma etching method. Subsequently, a protective oxide film **128** for protecting the structure on the front side of the semiconductor substrate **100** when etching the rear side thereof is deposited.

Referring to FIG. 17, the rear side of the semiconductor substrate **100** is etched. That is, a photoresist pattern defining an opening **130** for inserting an optical fiber thereinto is formed on the rear side of the semiconductor substrate **100**. The thermal oxide film **102** on the rear side of the semiconductor substrate **100** is etched by using the photoresist pattern as an etching mask, and then the substrate is etched up to under the first sacrificial oxide film **104** below the lower mirror **180** in a wet etching method or a Deep RIE (Deep Reactive Ion etching) method using a silicon etching solution such as KOH , thereby the opening **130** for inserting the optical fiber **160** thereinto is formed. The Deep RIE method uses SF_6 gas and C_4F_8 gas.

Referring to FIG. 18, after the opening **130** for inserting the optical fiber thereinto is formed in the rear side of the semiconductor substrate **100**, the protective oxide film **128** formed on the front side of the semiconductor substrate **100** is

removed. Subsequently, a conductive material is deposited on the sixth silicon film **126** and the third silicon film **114** and is patterned to form electrode pads **140, 142**. The electrode pad **140, 142** are electrically connected with the top silicon films in the lower mirror **180** and the upper mirror **182**, respectively, and the gap between the lower mirror **180** and the upper mirror **182** can be controlled by applying a voltage to the electrode pads **140, 142**.

Referring to FIG. **19**, the lower and upper mirrors **180, 182** having the laminated structure of the silicon film and the silicon oxide film is defined by a photolithography process in the pattern shape of the optical tuning mirror structure in FIG. **1**. Subsequently, in order to form the mirror structure pattern suspended by the connection means **155**, that is, the torsion bar or the spring, the etching process is performed until the first sacrificial oxide film **104**. For example, the silicon film may be etched with a plasma RIE process by using SF₄ or CF₄ gas, and the silicon oxide film may be etched by using CF₄ gas or CHF₆ gas.

Next, the second sacrificial oxide film **116** and the first sacrificial oxide film **104** are removed by a wet etching method using a hydrogen fluoride solution or a gas phase etching (GPE) method using anhydrous hydrogen fluoride (HF). Since the wet etching method and the gas phase etching method has an isotropic etching characteristics, the second sacrificial oxide film **116** between the upper mirror **182** and the lower mirror **180** is removed to form the optical tuning space, and the first sacrificial oxide film **104** between the lower mirror **180** and the semiconductor substrate **100** is etched by the optical fiber inserting opening **130** so that the lower mirror **180** is spaced away from the semiconductor substrate **100** by a predetermined distance in a floating shape.

The tunable wavelength optical filter having Fabry-Perot structure in which a pair of mirrors **180, 182** having the optical reflective layer composed of the multi-layer laminated structure of the silicon film/silicon oxide film are driven by the electrostatic force can be manufactured.

On the other hand, without forming the lower mirror **180** and the upper mirror **182** in a pair, wafers or cut individual chips on each which only the lower mirror **180** is formed and which the steps of forming the electrode **140** and the optical fiber inserting opening **130** and removing the sacrificial oxide film **104** are performed are aligned and attached opposite to each other by a predetermined distance by using the spacer layer, thereby the tunable wavelength optical filter having Fabry-Perot structure can be manufactured. This structure will be further explained as follows: First, a sacrificial oxide film for floating a mirror is formed on a semiconductor substrate. At this time, before forming the sacrificial oxide film, thermal oxide films may be on the both sides of the semiconductor substrate. Subsequently, conductive silicon films and oxide patterns for defining the mirror region are sequentially laminated on the sacrificial oxide film and another conductive silicon film is laminated to form the mirror. Next, the rear side of the semiconductor substrate is etched to form the opening for inserting an optical fiber thereinto. Subsequently, an electrode pad for controlling the gap between the mirrors by the electrostatic force is formed. Next, the silicon film around the mirror is etched by a dry etching method to expose the sacrificial oxide film, so that the mirror is suspended by the connecting means. Subsequently, in order to float the mirror on the semiconductor substrate, the sacrificial oxide film is etched. Finally, two semiconductor substrates passed through the above-mentioned processes are prepared, and are attached to each other while sandwiching a spacer therebetween such that the mirrors of the semiconductor substrates are opposite

to each other, thereby the tunable wavelength optical filter having the Fabry-Perot structure is completed.

Further, the electrode pads **140, 142** can be electrically connected to the top silicon film in the lower mirror **180** and the top silicon film in the upper mirror **182**, respectively, to adjust the tuning gap. But, in an alternative method, the electrode pads can be formed in the silicon film forming the lower mirror **180** and the silicon substrate **100** to adjust the gap between the lower mirror and the substrate **100**, thereby the micro-gap between the upper and the lower mirrors **182, 180** can be relatively adjusted.

In addition, both the upper mirror **182** and the lower mirror **180** are suspended by the connecting means **155**, but the structure that only the upper mirror **182** is suspended by the connecting means **155** and the lower mirror **180** is not floated on the semiconductor substrate **100**, that is, is embedded in the substrate can be formed. By performing the dry etching process performed to suspend the mirror by the connecting means **155** until the second sacrificial oxide film **116** is exposed, the structure that only the upper mirror **182** is suspended by the connecting means **155** is accomplished after etching the sacrificial oxide film **116**.

According to the present invention, a multi-layer thin film mirror having a high optical reflectivity which comprised of the silicon film (polysilicon) and the silicon oxide film having a large optical reflectivity difference therebetween can be implemented on a silicon wafer, and an optical filter device floated on the substrate can be manufactured by using the high etching selectivity of the silicon oxide film and the silicon film. Particularly, the pattern except for the mirror region having the multi-layer laminated structure of the silicon film/silicon oxide film is formed by laminating the silicon films, thereby the tunable wavelength optical filter having the Fabry-Perot structure can be easily manufactured by only a general silicon semiconductor IC process. The present invention can manufacture the tunable wavelength optical filter by a surface micro-machining technique by using a basic technique of the silicon semiconductor process established already. In addition, the manufacturing structure and the process thereof is simple, thereby the bulk production is performed a consistent process at a low cost.

Further, according to the present invention, the consistent process using the semiconductor substrate can be performed by using general semiconductor processes and materials, and the tunable wavelength optical filter and an IC circuit for controlling and driving the same can be simultaneously integrated on one substrate, due to the compatibility with the semiconductor IC process.

Although the present invention has been illustrated and described with respect to exemplary embodiments thereof, the present invention should not be understood as limited to the specific embodiment, and it should be understood by those skilled in the art that the foregoing and various other changes, omission and additions may be made therein and thereto, without departing from the spirit and scope of the present invention.

The invention claimed is:

1. A method of manufacturing a tunable wavelength optical filter, comprising the steps of:

- (a) forming a first sacrificial oxide film for floating a lower mirror on a semiconductor substrate;
- (b) sequentially laminating conductive silicon films and oxide films for defining a mirror region on said first sacrificial oxide film in a multi-layer and laminating another conductive silicon film to form a lower mirror;
- (c) forming a second sacrificial film on the resultant;

9

- (d) sequentially laminating conductive silicon films and oxide films for defining the mirror region on said second sacrificial oxide film in a multi-layer and laminating another conductive silicon film to form an upper mirror;
- (e) etching the rear side of said semiconductor substrate to form an opening for inserting an optical fiber thereinto;
- (f) forming electrode pads for controlling the gap between said lower mirror and said upper mirror by an electrostatic force;
- (g) etching the silicon film around said upper mirror in a dry etching method to expose said second sacrificial oxide film, such that said upper mirror is suspended by a connecting means; and
- (h) forming an optical tuning space between said lower mirror and said upper mirror and etching said first sacrificial oxide film and said second sacrificial oxide film such that said lower mirror is floated on said semiconductor substrate.

2. The method of manufacturing the tunable wavelength optical filter according to claim 1, further comprising the structure of lower mirror embedded type that only the upper mirror is suspended by the connecting means and the lower mirror is not floated on the semiconductor substrate, after the step (g) and before the step (h).

3. The method of manufacturing the tunable wavelength optical filter according to claim 1, wherein said first and second sacrificial oxide films are etched by a wet etching method using a hydrogen fluoride solution or a gas phase etching method using anhydrous hydrogen fluoride which the etching speed of the sacrificial oxide film is quicker than that of the silicon film.

4. The method of manufacturing the tunable wavelength optical filter according to claim 1, wherein said silicon film is formed so as to have a thickness of $(2m+1)\lambda/4n$ ($m=0, 1, 2, \dots$),

wherein λ is the wavelength of the light source, and n is the optical refractive index of the silicon film.

5. The method of manufacturing the tunable wavelength optical filter according to claim 1, wherein said oxide film is formed so as to have a thickness of $(2m+1)\lambda/4n$ ($m=0, 1, 2, \dots$),

wherein λ is the wavelength of the light source, and n is the optical refractive index of the oxide film.

6. The method of manufacturing the tunable wavelength optical filter according to claim 1, further comprising the step of forming thermal oxide films on the both sides of the semiconductor substrate, before forming said first sacrificial oxide film.

7. The method of manufacturing the tunable wavelength optical filter according to claim 1, wherein said the step (b) comprises the steps of:

depositing a first conductive silicon film on said first sacrificial oxide film,

10

depositing a first oxide film on said first silicon film and patterning the first oxide film to define the mirror region; depositing a second silicon film on said first silicon film and said patterned first oxide film;

depositing a second oxide film on said second silicon film and patterning the second oxide film to define the mirror region; and

forming a third conductive silicon film on said second silicon film and said patterned second oxide film.

8. The method of manufacturing the tunable wavelength optical filter according to claim 1, wherein said [the] step (d) comprises the steps of:

depositing a first conductive silicon film on said second sacrificial oxide film,

depositing a first oxide film on said first silicon film and patterning the first oxide film to define the mirror region; and

depositing a second silicon film on said first silicon film and said patterned first oxide film;

depositing a second oxide film on said second silicon film and patterning the second oxide film to define the mirror region; and

forming a third conductive silicon film on said second silicon film and said patterned second oxide film].

9. A method of manufacturing a tunable wavelength optical filter, comprising:

forming a first sacrificial oxide film;

sequentially laminating silicon films and oxide films on the first sacrificial oxide film to form a lower mirror;

forming a second sacrificial film on the lower mirror;

sequentially laminating silicon films and oxide films on the second sacrificial oxide film to form an upper mirror;

etching the second sacrificial oxide film to form a gap between the lower minor and the upper minor; and

forming electrode pads for controlling the gap.

10. The method of claim 9, further comprising:

etching the silicon film around the upper mirror to expose the second sacrificial oxide film; and

etching the second sacrificial oxide film, whereby floating the lower mirror on a semiconductor substrate.

11. The method of claim 9, wherein the electrode pad controls the gap by an electrostatic force.

12. The method of claim 9, wherein at least one of the upper mirror and the lower minor is suspended by a connecting means.

13. The method of claim 9, wherein the first sacrificial oxide film is formed on a semiconductor substrate.

14. The method of claim 13, further comprising etching the rear side of the semiconductor substrate to form an opening for inserting an optical fiber therein.

* * * * *