

US00RE44342E

(19) **United States**
(12) **Reissued Patent**
Drehmel et al.

(10) **Patent Number:** **US RE44,342 E**
(45) **Date of Reissued Patent:** **Jul. 2, 2013**

(54) **BUS ARCHITECTURE EMPLOYING VARYING WIDTH UNI-DIRECTIONAL COMMAND BUS**

(75) Inventors: **Robert Allen Drehmel**, Goodhue, MN (US); **Kent Harold Haselhorst**, Byron, MN (US); **Russel Dean Hoover**, Rochester, MN (US); **James Anthony Marcella**, Rochester, MN (US)

(73) Assignee: **International Business Machine Corporation**, Armonk, NY (US)

4,977,498 A *	12/1990	Rastegar et al.	711/128
5,228,134 A	7/1993	MacWilliams et al.	
5,355,467 A	10/1994	MacWilliams et al.	
5,408,646 A	4/1995	Olnowich et al.	
5,537,394 A	7/1996	Abe et al.	370/17
5,544,342 A	8/1996	Dean	
5,553,266 A	9/1996	Metzger et al.	
5,557,266 A	9/1996	Calvignac et al.	340/825.02
5,604,735 A	2/1997	Levinson et al.	370/360
5,630,095 A	5/1997	Snyder	
5,659,710 A	8/1997	Sherman et al.	
5,787,083 A	7/1998	Iwamoto et al.	370/389
5,802,054 A	9/1998	Bellenger	

(Continued)

(21) Appl. No.: **11/203,652**

(22) Filed: **Aug. 15, 2005**

Related U.S. Patent Documents

Reissue of:

(64) Patent No.: **6,526,469**
Issued: **Feb. 25, 2003**
Appl. No.: **09/439,068**
Filed: **Nov. 12, 1999**

U.S. Applications:

(62) Division of application No. 10/747,820, filed on Dec. 30, 2003.

(51) **Int. Cl.**
G06F 12/00 (2006.01)
G06F 13/00 (2006.01)

(52) **U.S. Cl.**
USPC **711/5; 710/306; 711/105**

(58) **Field of Classification Search**
None
See application file for complete search history.

(56) **References Cited**

U.S. PATENT DOCUMENTS

4,644,532 A	2/1987	George et al.	370/94
4,667,305 A	5/1987	Dill et al.	
4,747,100 A	5/1988	Roach et al.	370/86
4,864,563 A	9/1989	Pavey et al.	370/94.1

Primary Examiner — Kevin Verbrugge

(74) Attorney, Agent, or Firm — Fitzpatrick, Cella, Harper & Scinto

(57) **ABSTRACT**

A processor-memory bus comprises a command portion for transmitting addresses and commands, having a unidirectional input portion for transmitting commands to a central repeater unit, and a unidirectional broadcast portion for broadcasting commands from the repeater. The input portion comprises a plurality of links running from different devices, wherein each link is less than the full width of the broadcast bus portion. A command is transmitted over the input portion in a plurality of bus cycles, and broadcast over the broadcast portion in a single bus cycle. Since multiple input links connect to the central command repeater, it is possible to keep the broadcast bus full notwithstanding the fact that multiple bus cycles are required to transmit an individual command on the input portion. Preferably, the links are arranged hierarchically, from processors to local repeaters, from local repeaters to the central repeater, and back again. Preferably, the central repeater globally arbitrates the bus, and once the bus is granted, the command propagates along each link at pre-defined clock cycles from bus grant. In the preferred embodiment, addresses/commands and data are transmitted on essentially separate paths having different topologies, and at different times, and are arbitrated separately.

59 Claims, 39 Drawing Sheets

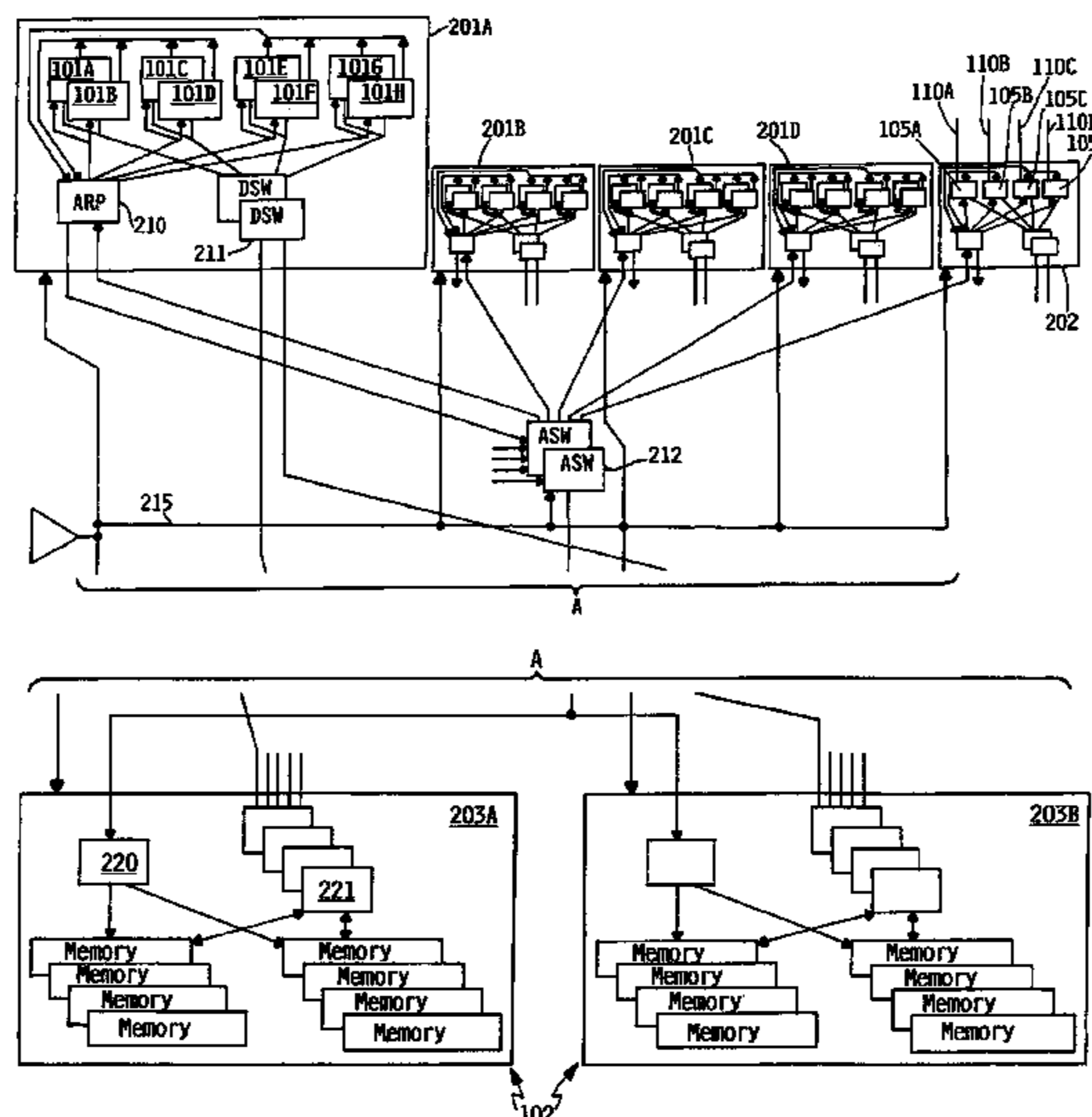

US RE44,342 E

Page 2

U.S. PATENT DOCUMENTS

5,802,565 A	9/1998	McBride et al.	711/125	5,901,294 A	5/1999	Tran et al.	
5,805,798 A	9/1998	Kearns et al.		5,911,052 A	6/1999	Singhal et al.	
5,848,145 A	12/1998	Gallagher et al.	379/220	5,913,044 A	6/1999	Tran et al.	
5,884,036 A	3/1999	Haley		5,923,893 A	7/1999	Moyer et al.	
5,893,921 A	4/1999	Bucher et al.	711/146	6,247,100 B1 *	6/2001	Drehmel et al.	710/309
5,900,017 A	5/1999	Genduso et al.	711/146	6,530,033 B1 *	3/2003	Raynham et al.	714/5

* cited by examiner

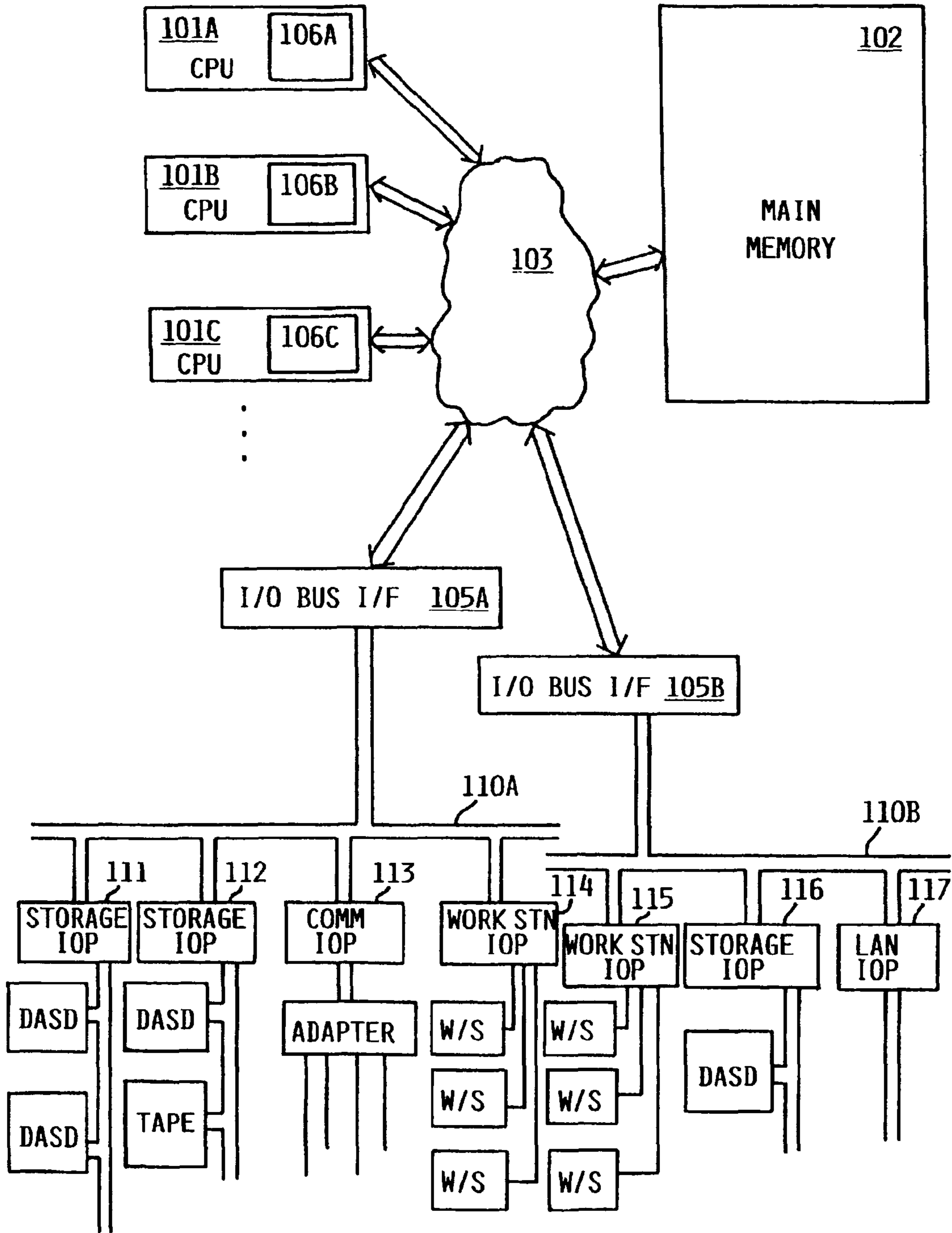

FIG. 1

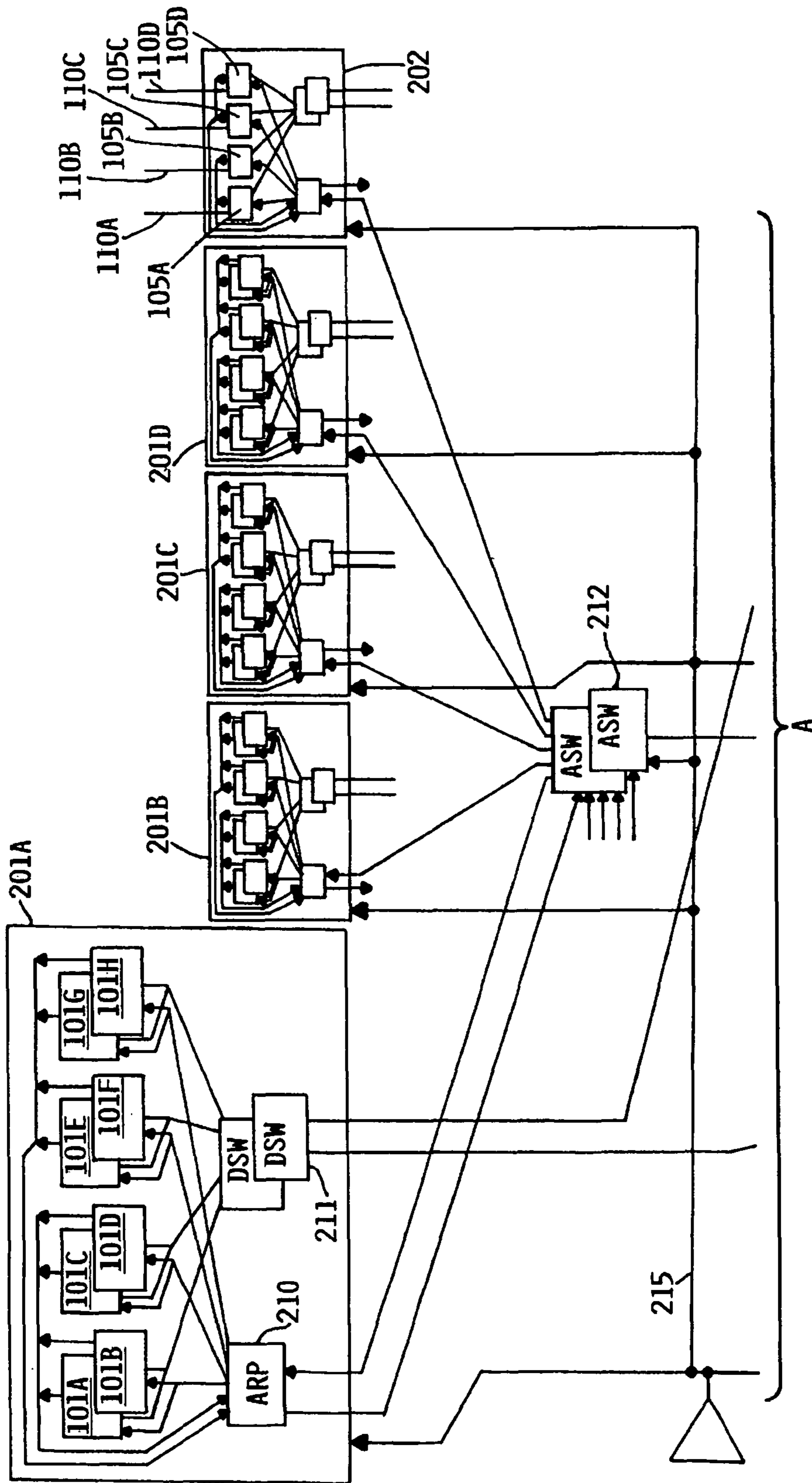

FIG. 2A

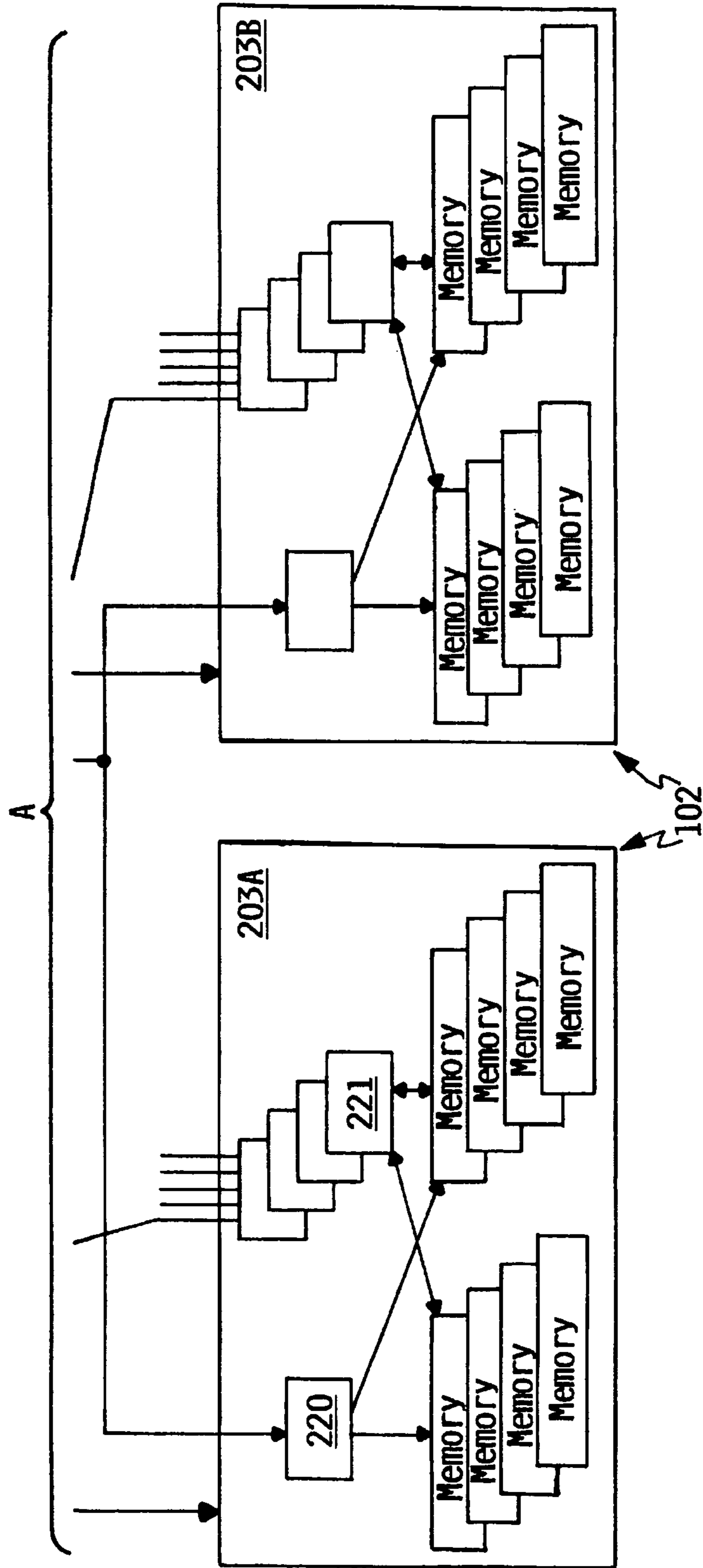

FIG. 2B

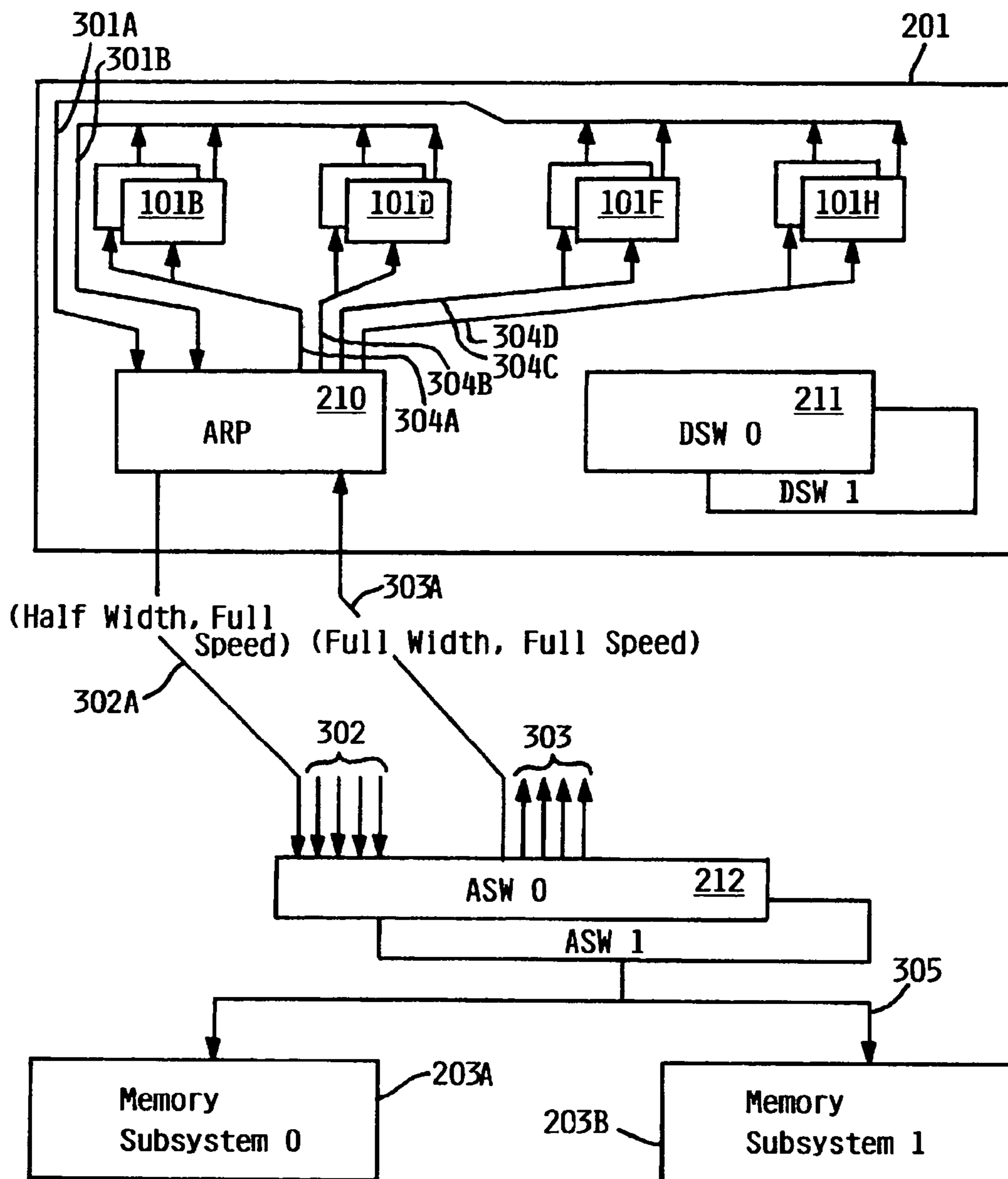

FIG. 3

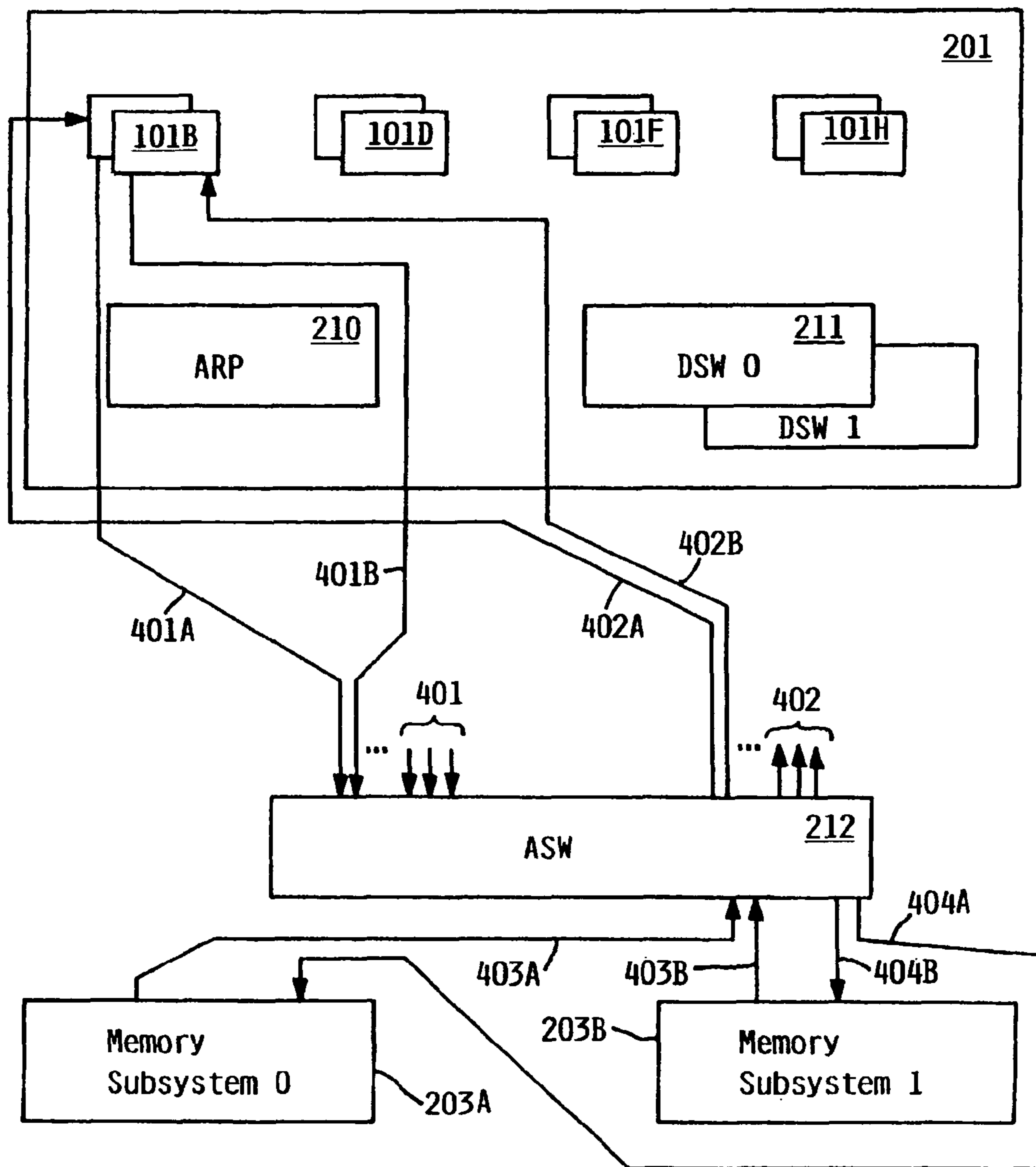

FIG. 4

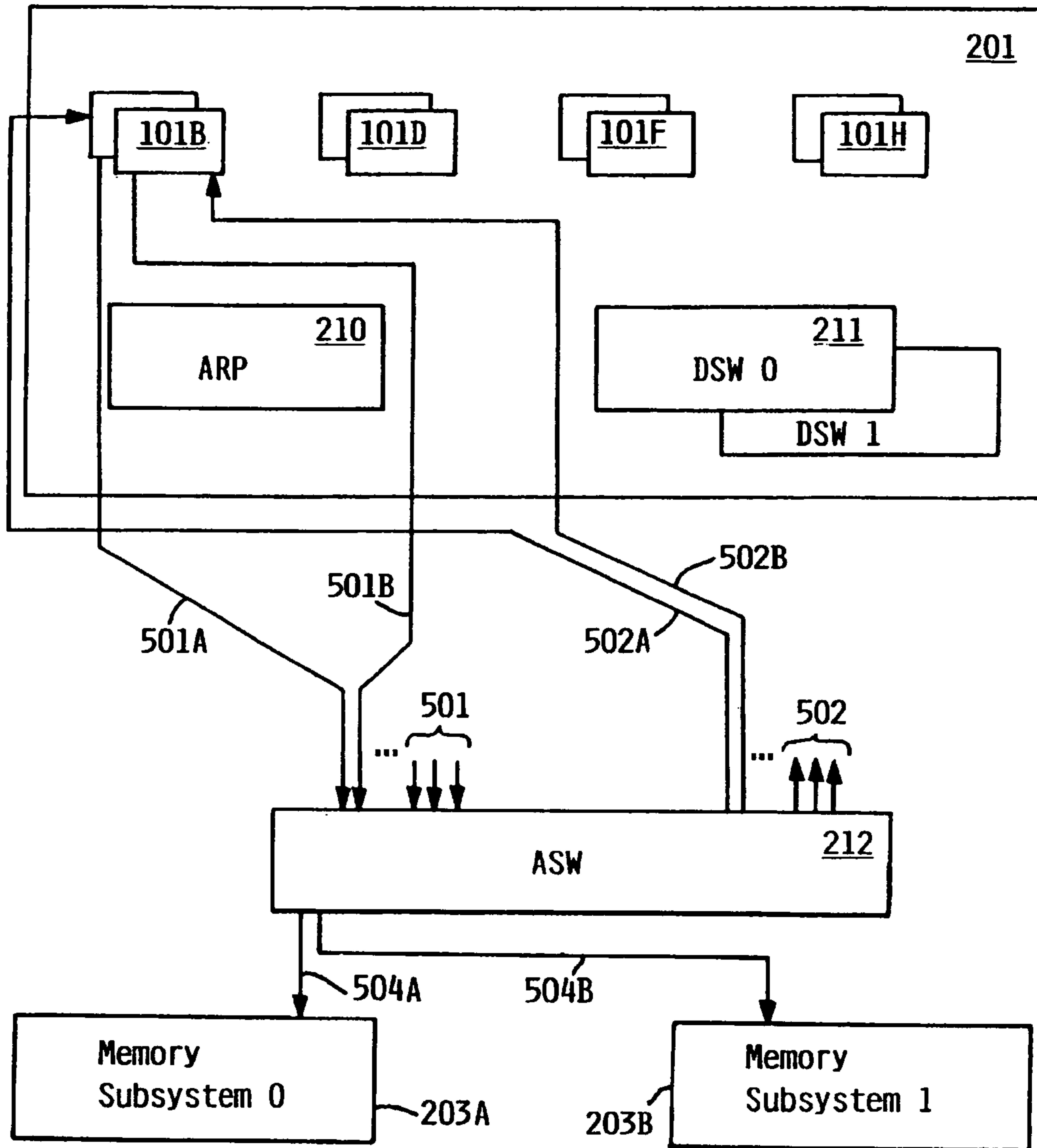

FIG. 5

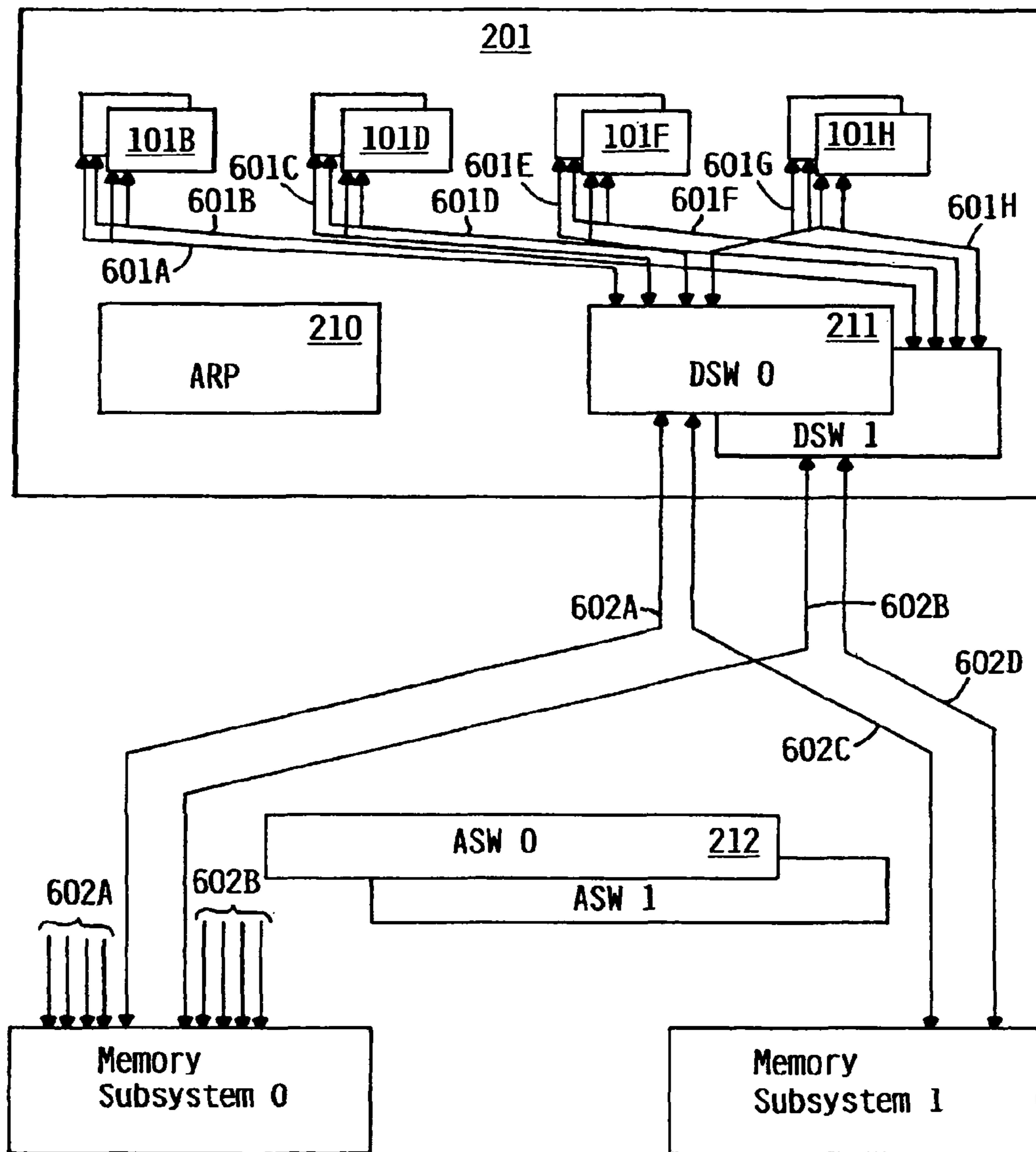

FIG. 6

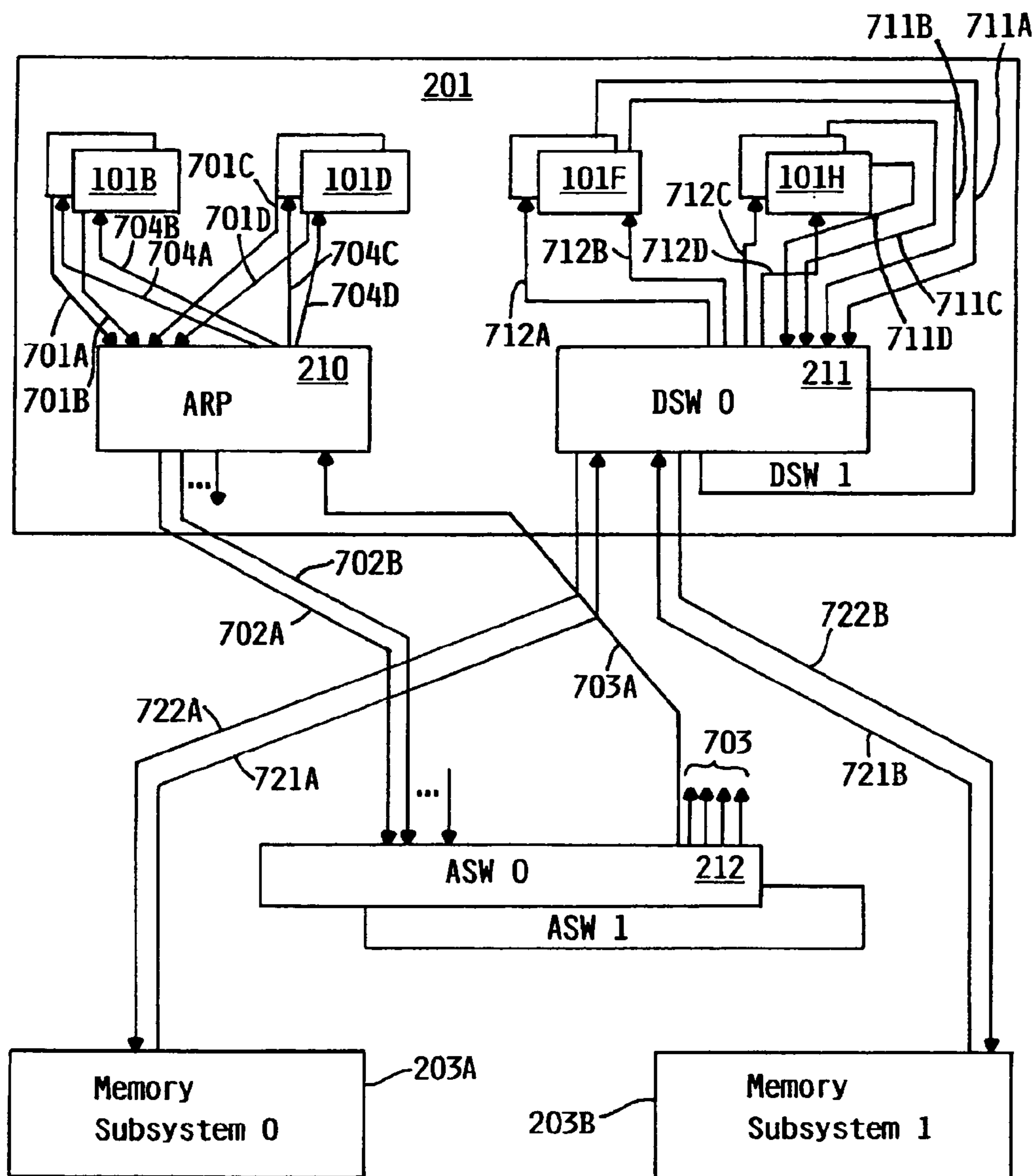

FIG. 7

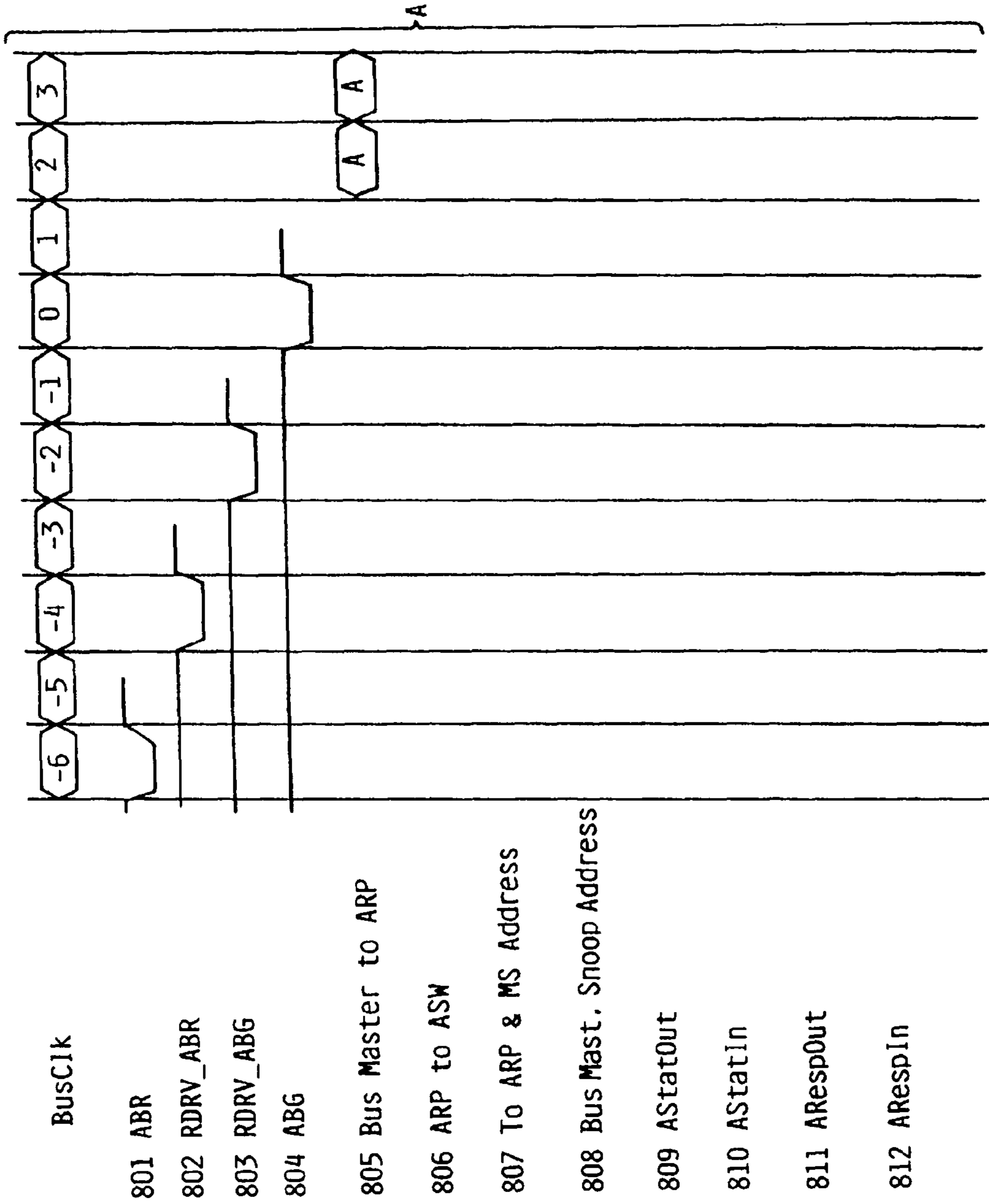

FIG. 8A

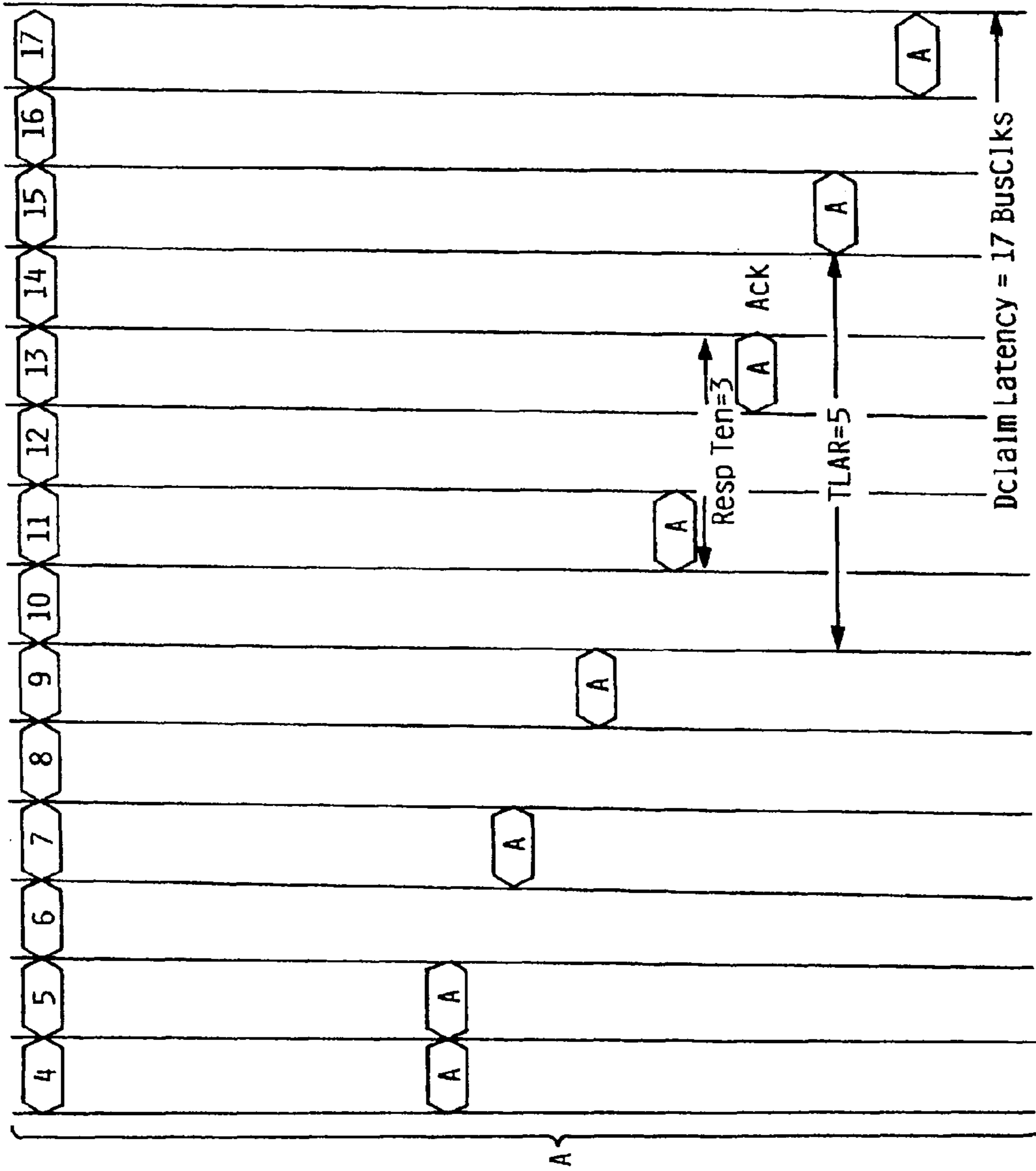

FIG. 8B

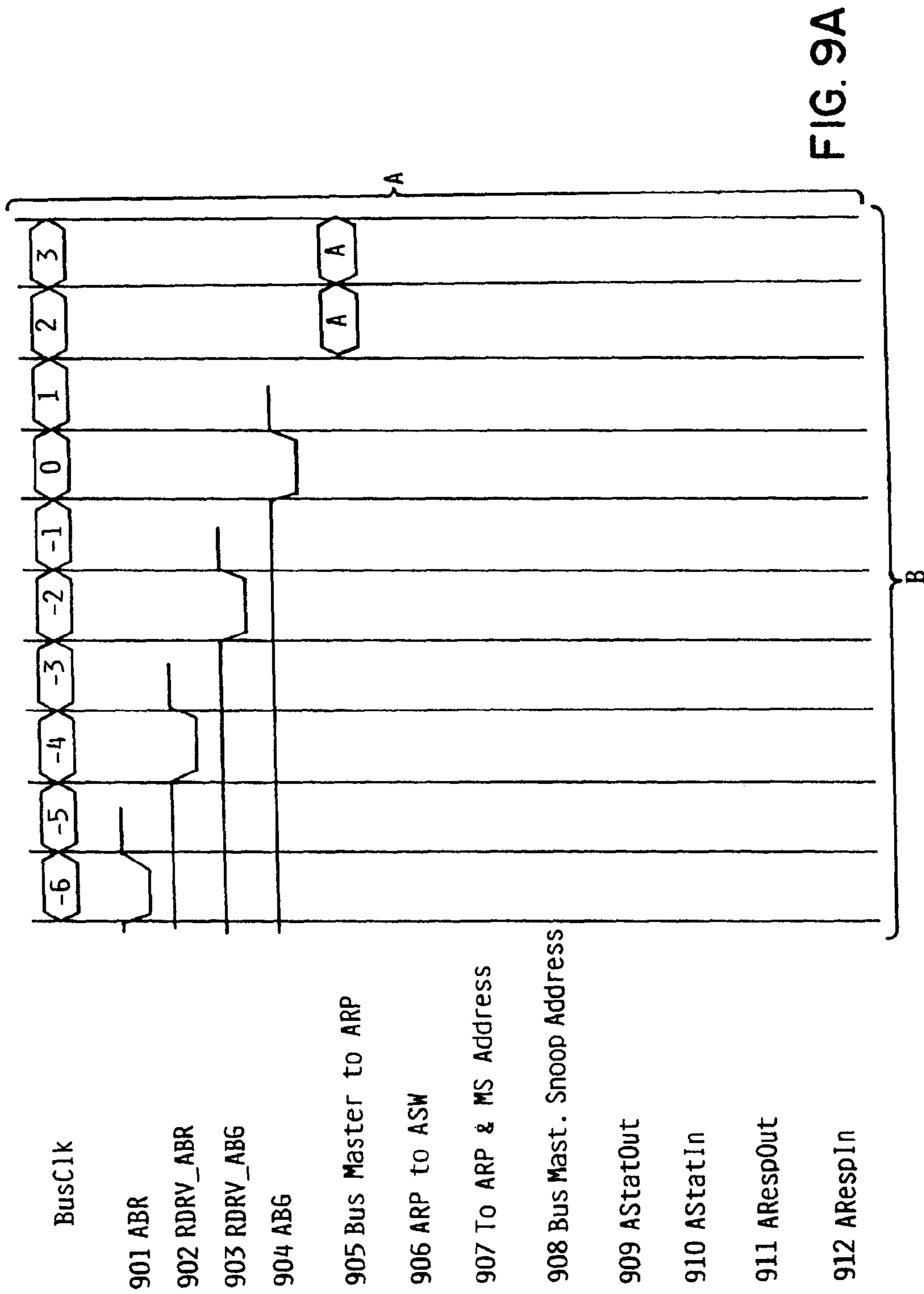
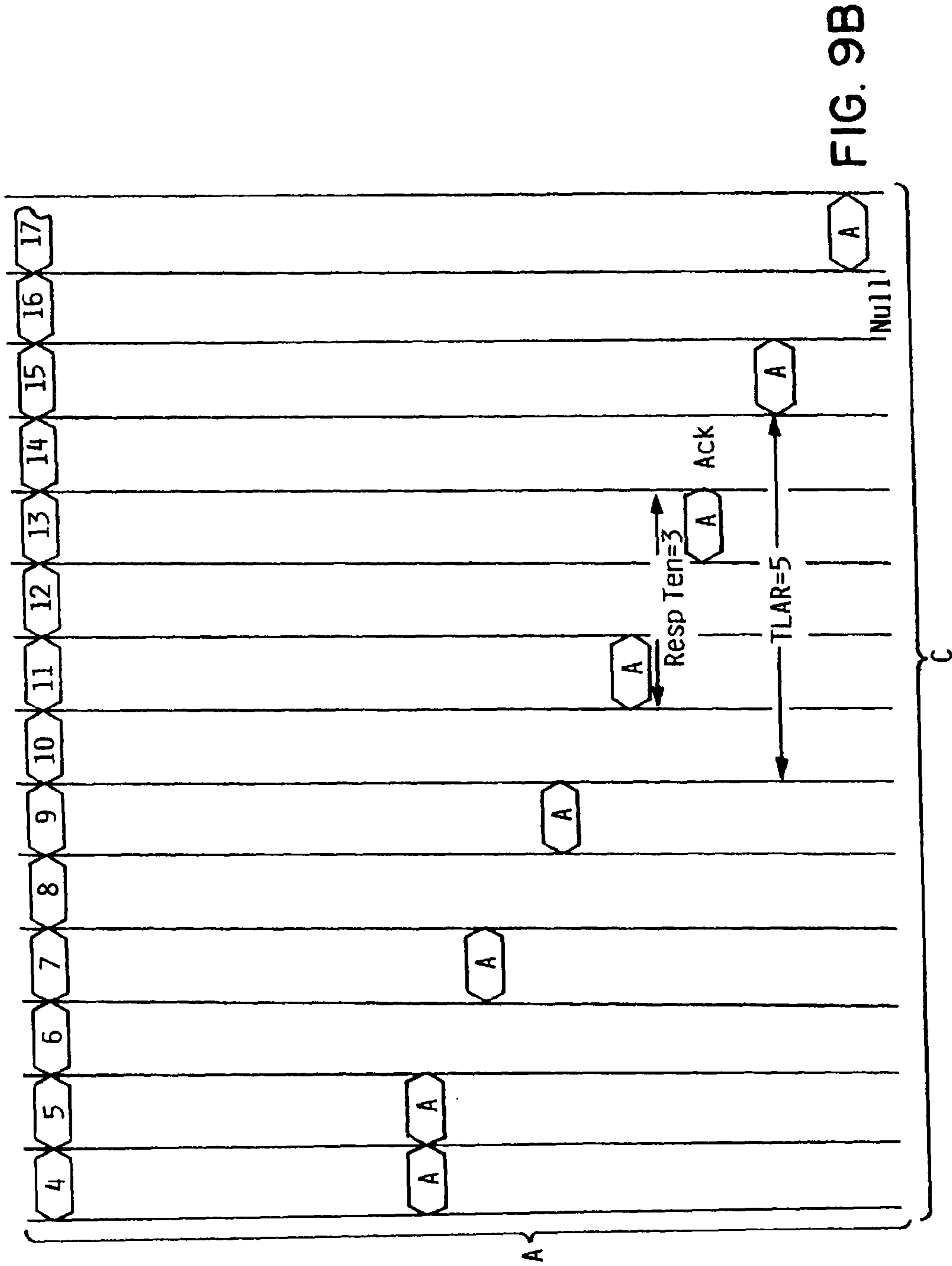

FIG. 9A



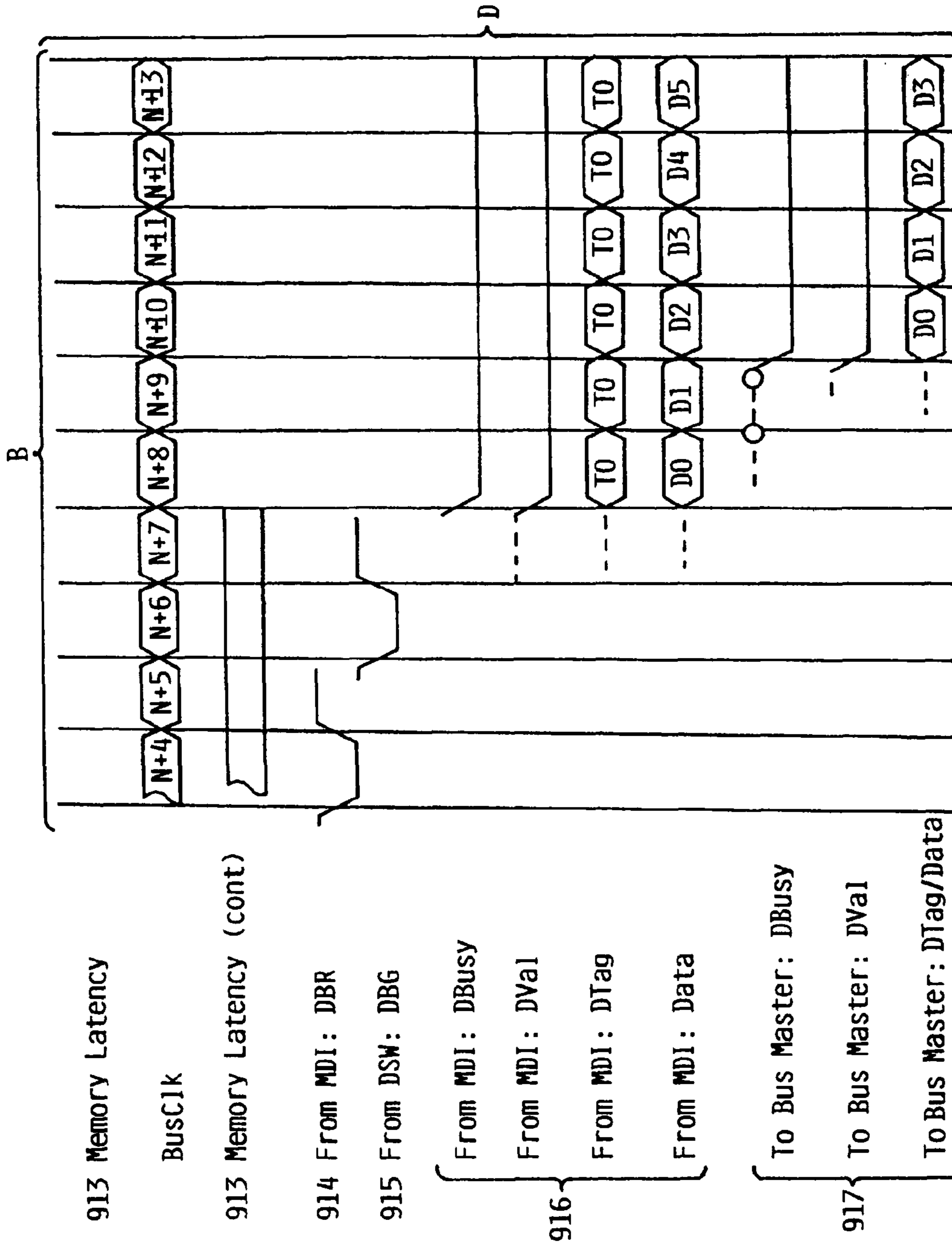

FIG. 9C

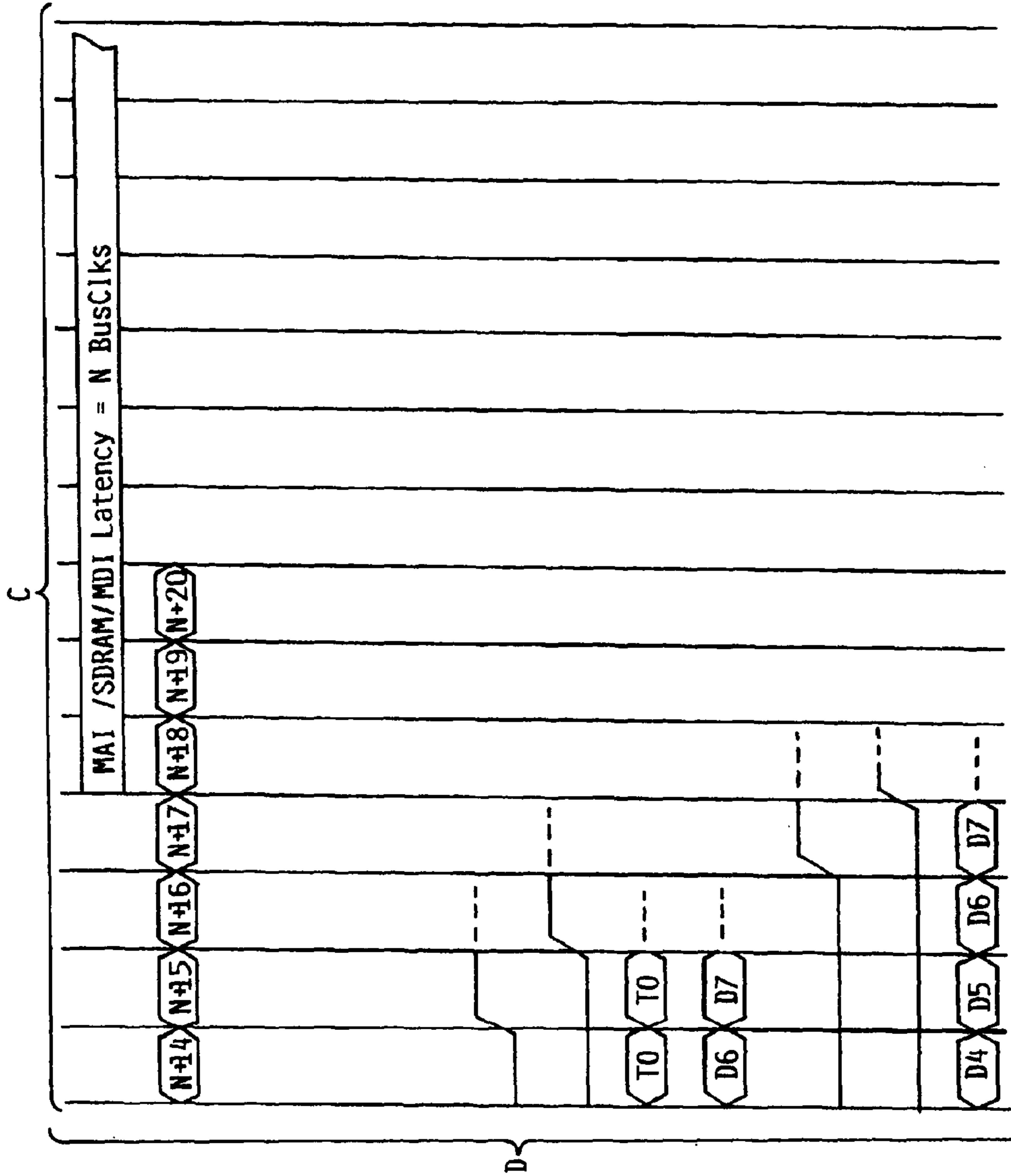

FIG. 9D

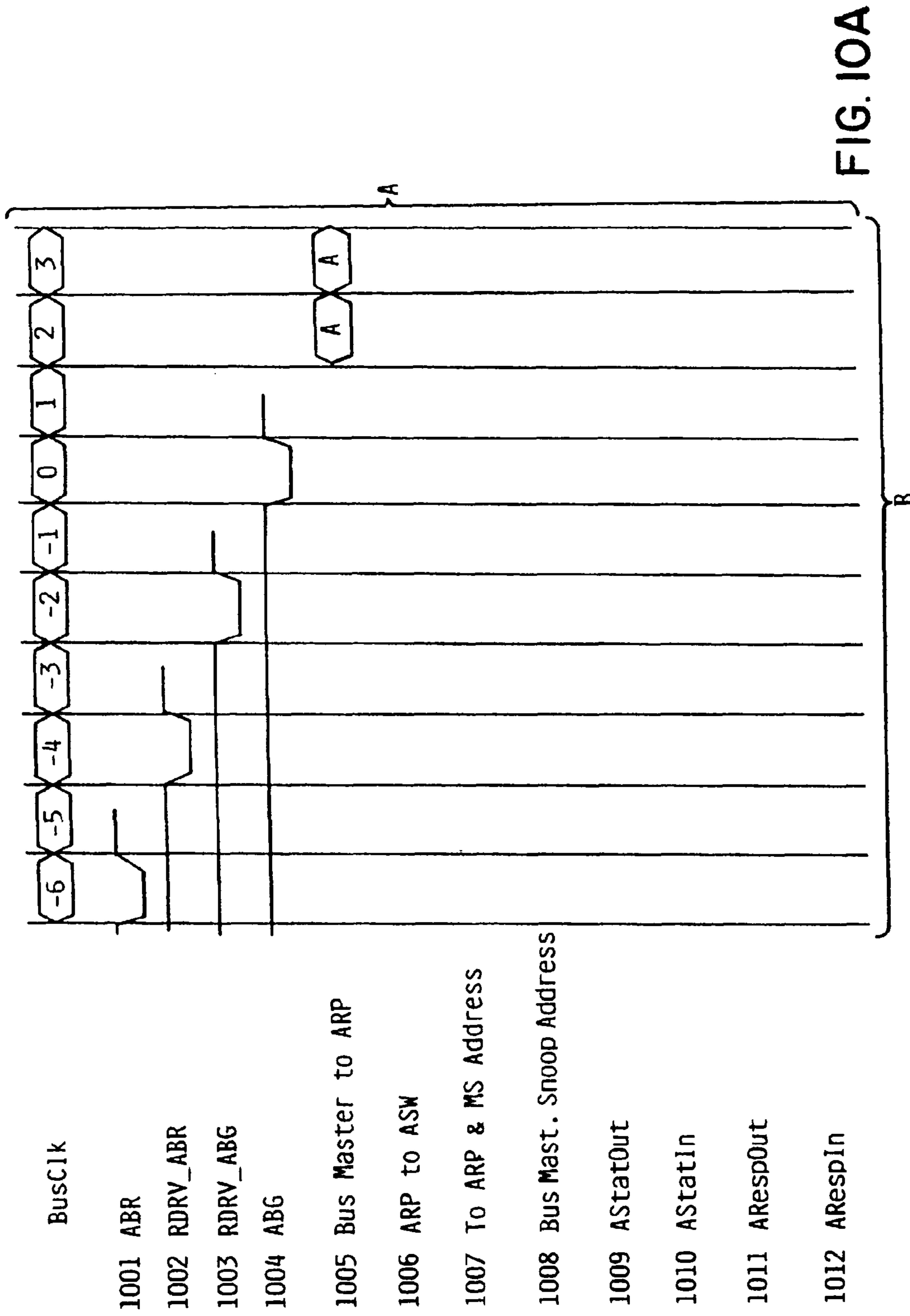

FIG. 10A

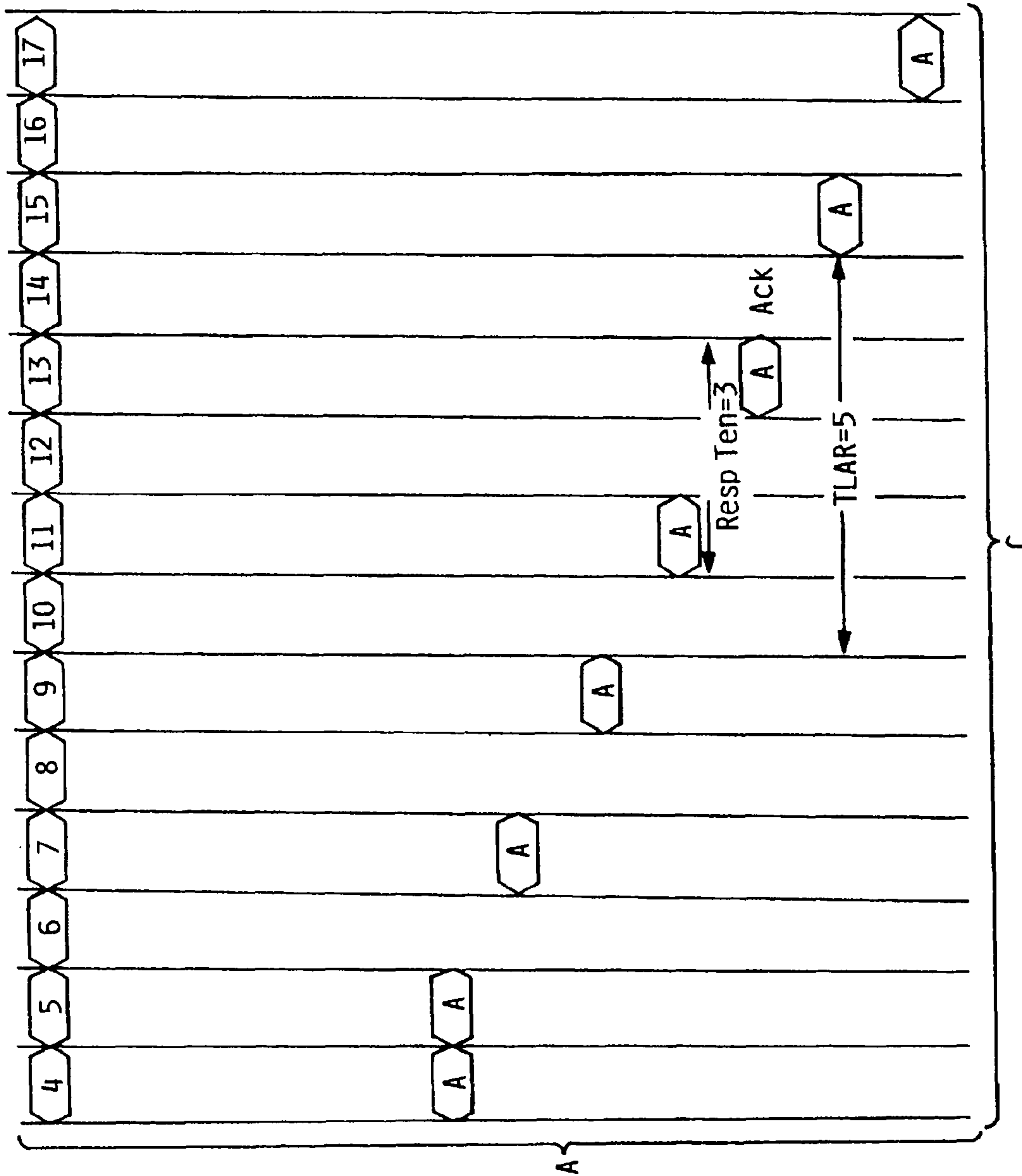

FIG. 10B

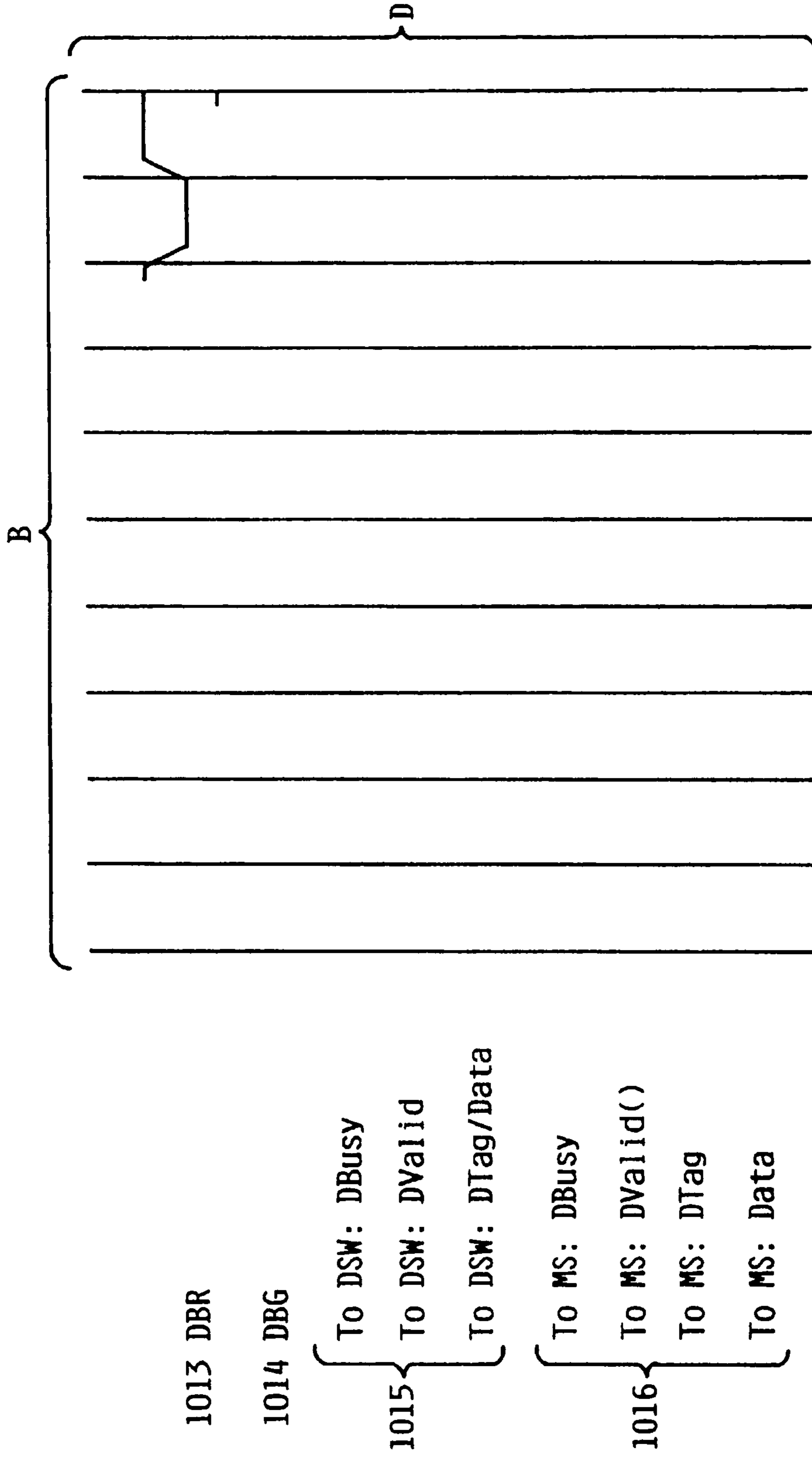

FIG. 10C

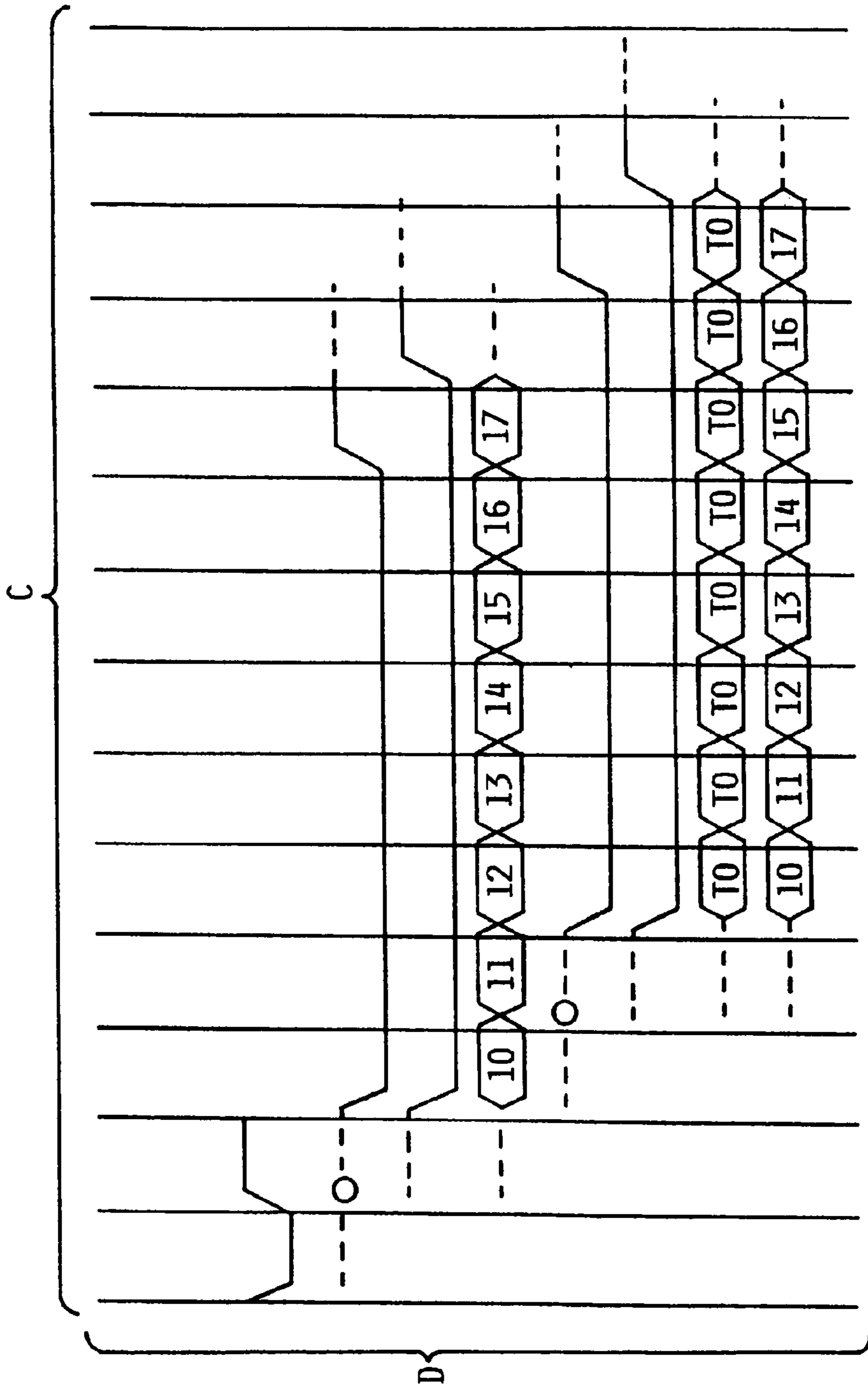

FIG. 10D

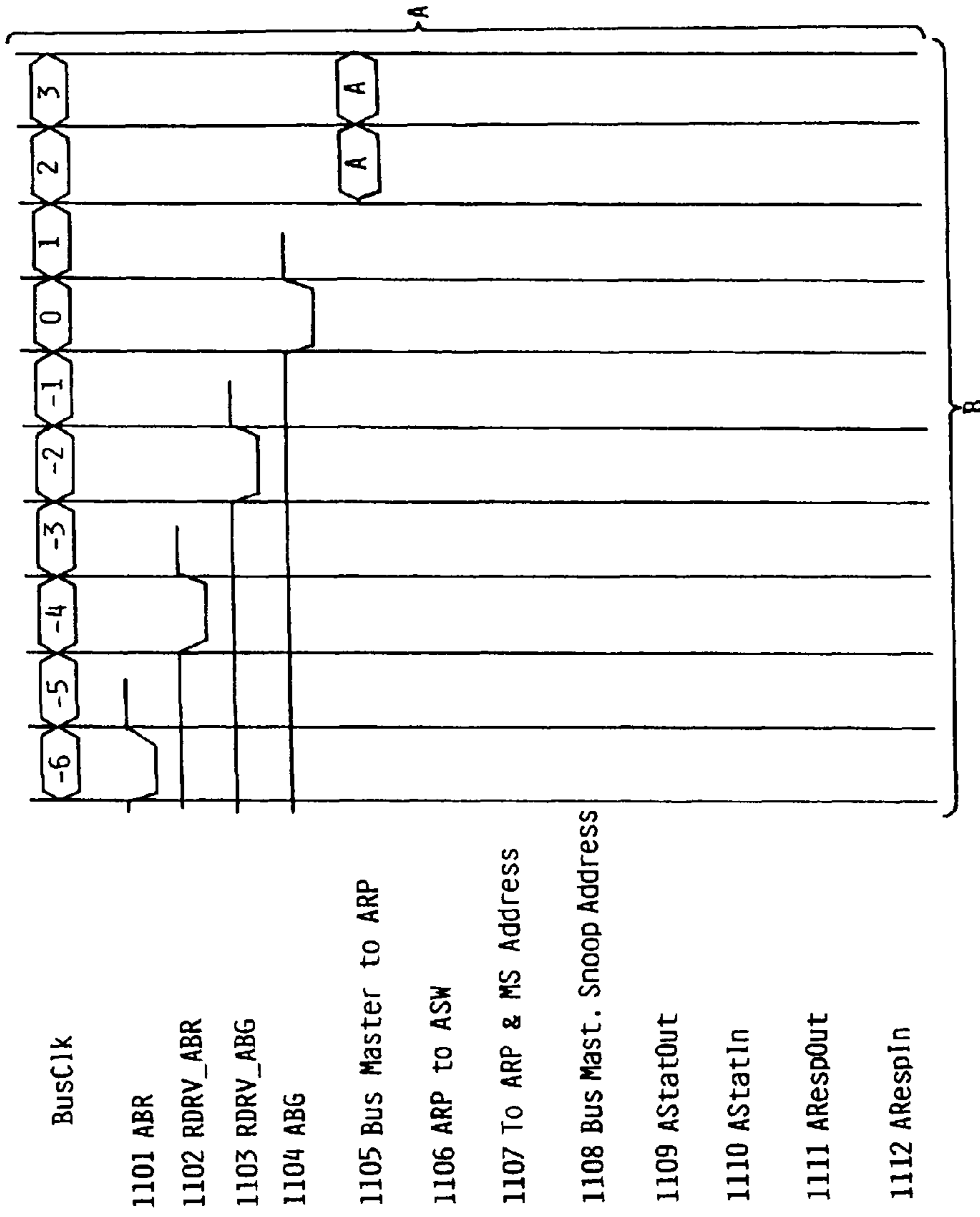

FIG. 11A

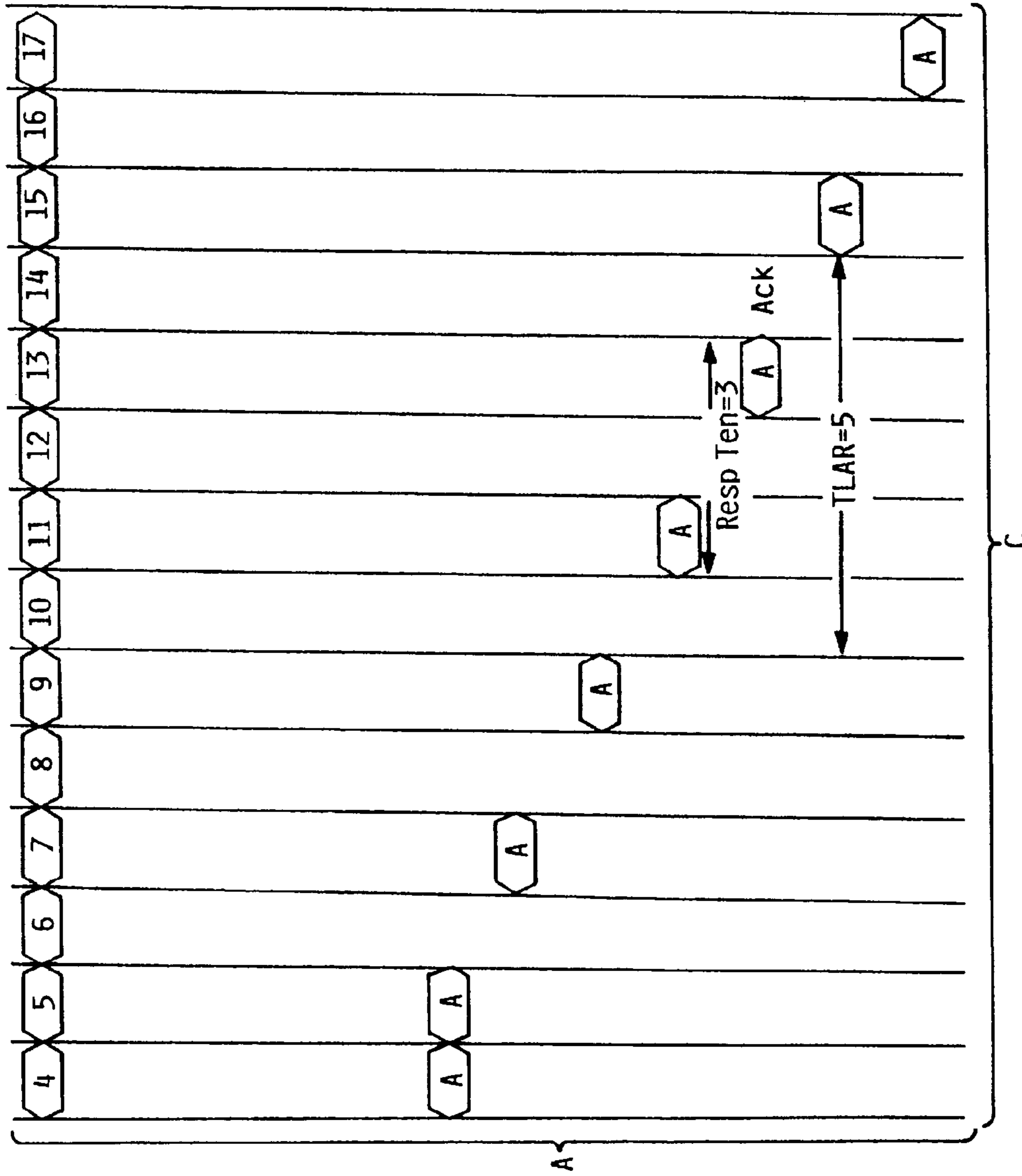

FIG. 11B

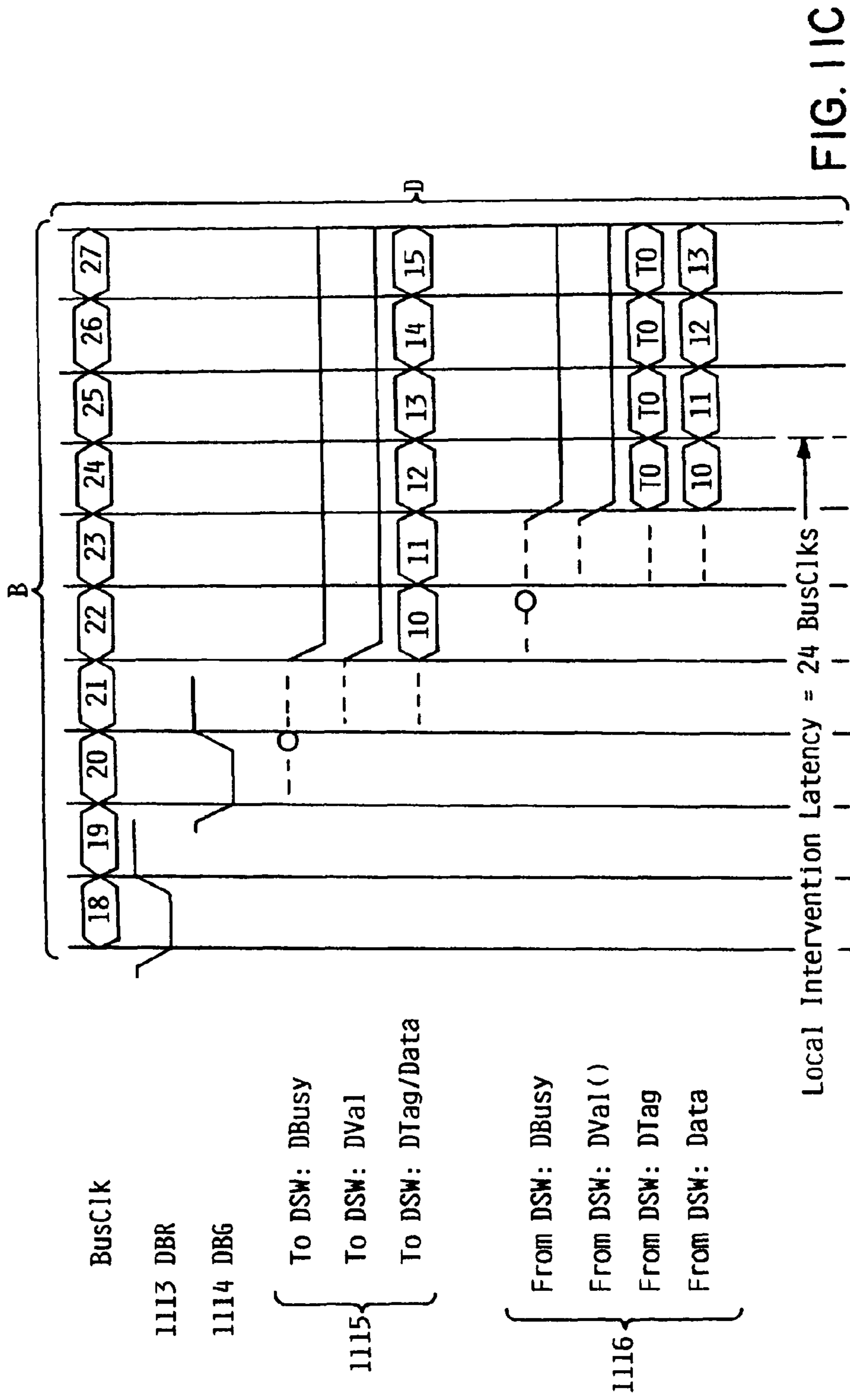

FIG. 11C

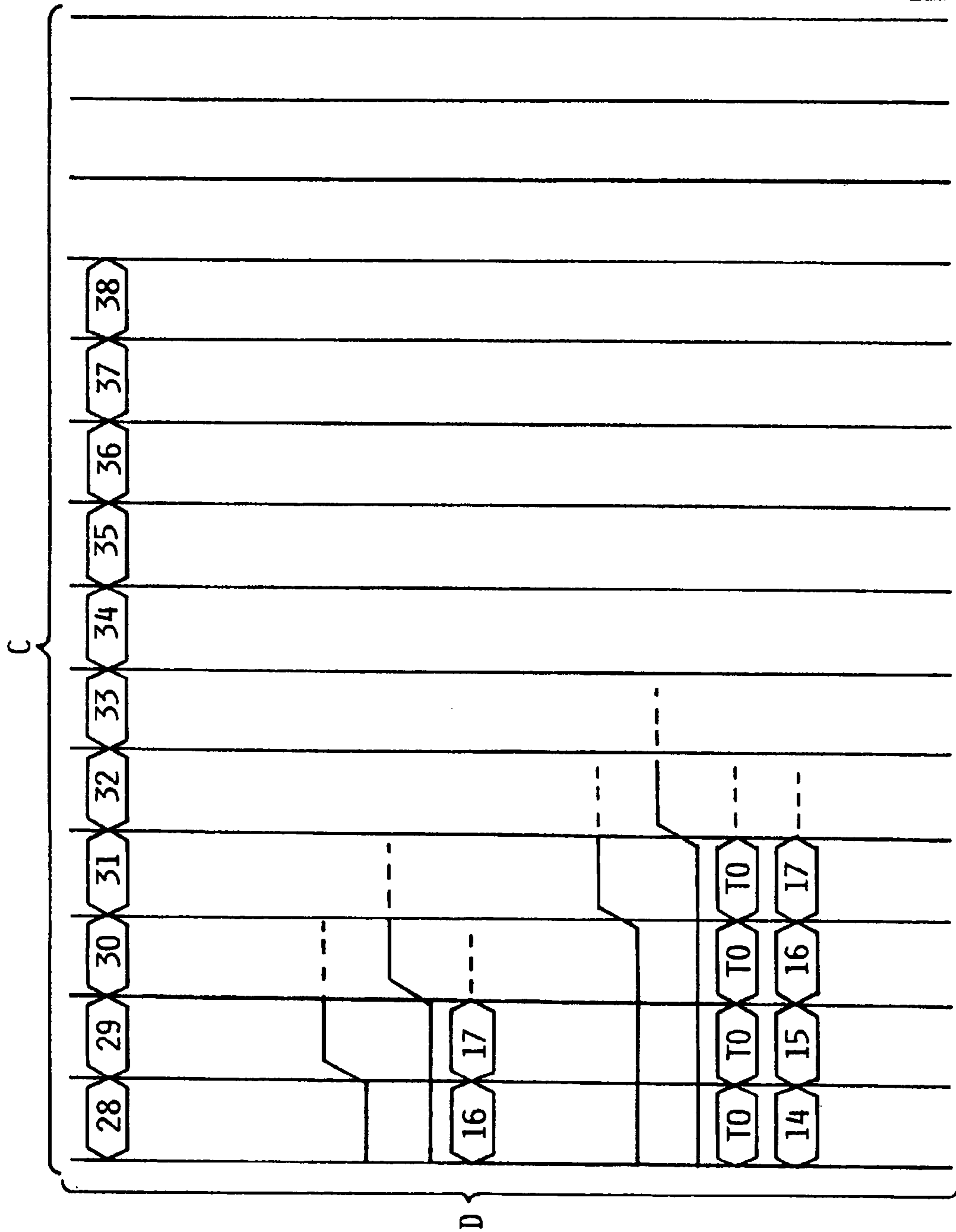
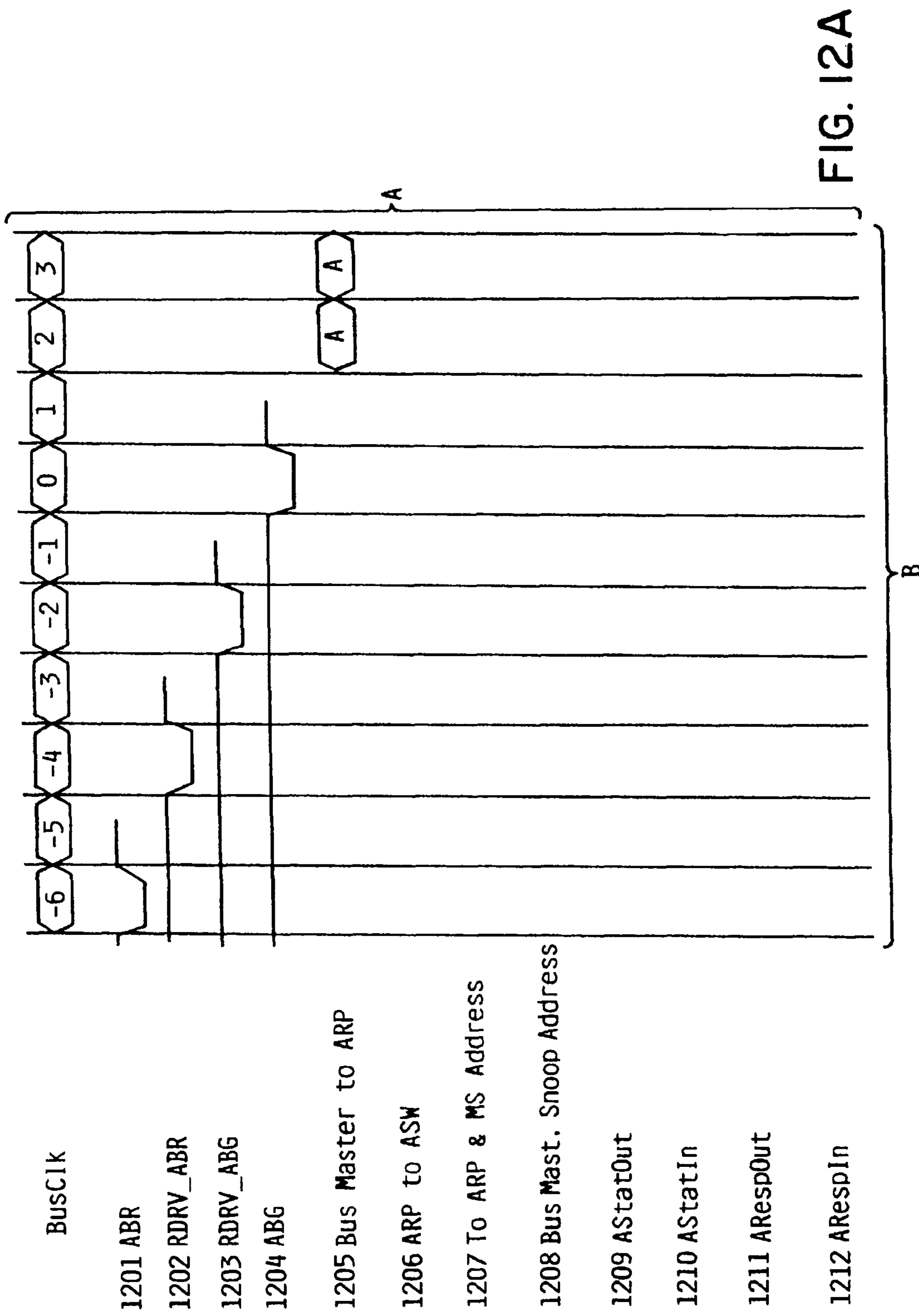
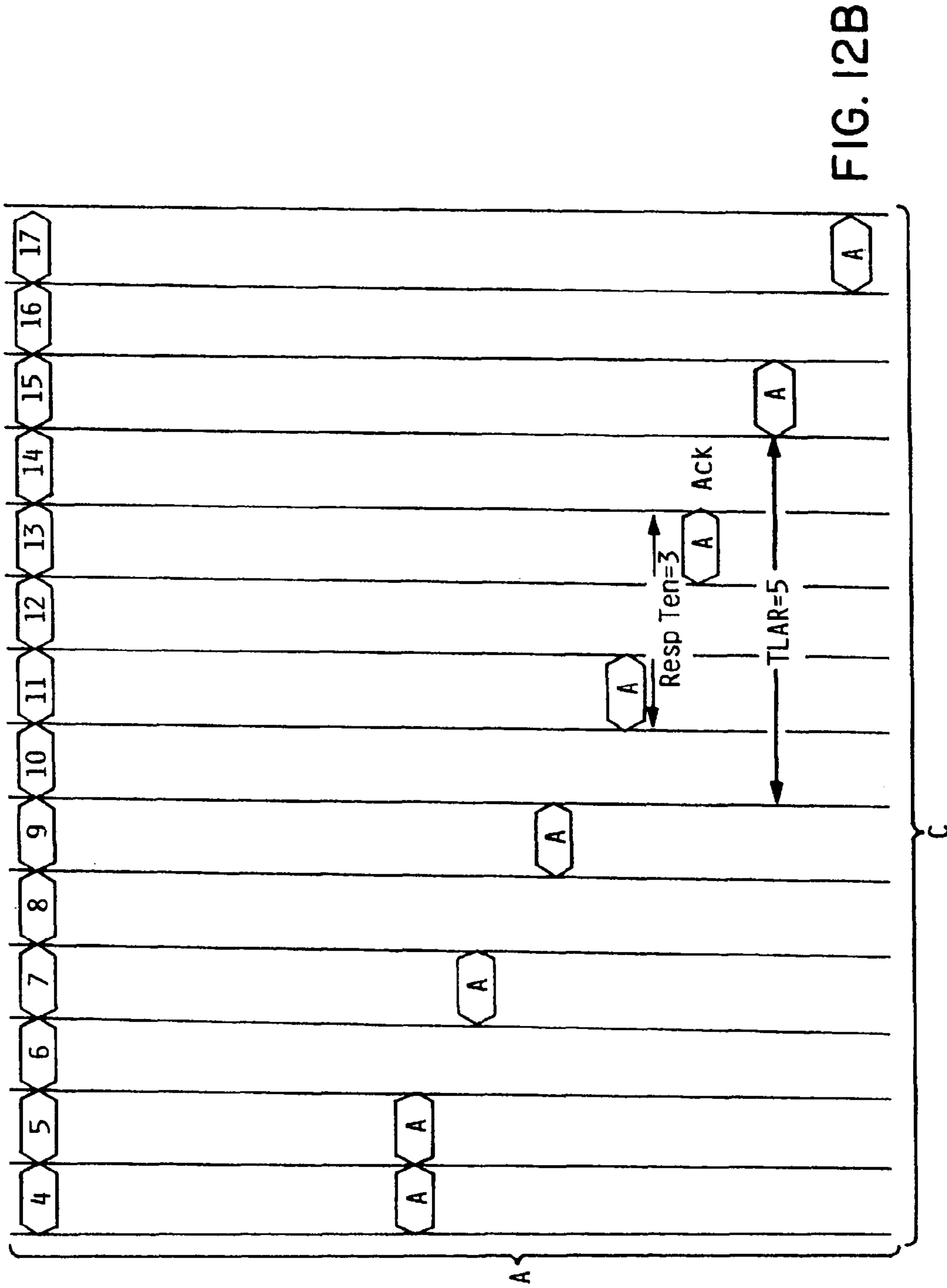

FIG. 11D





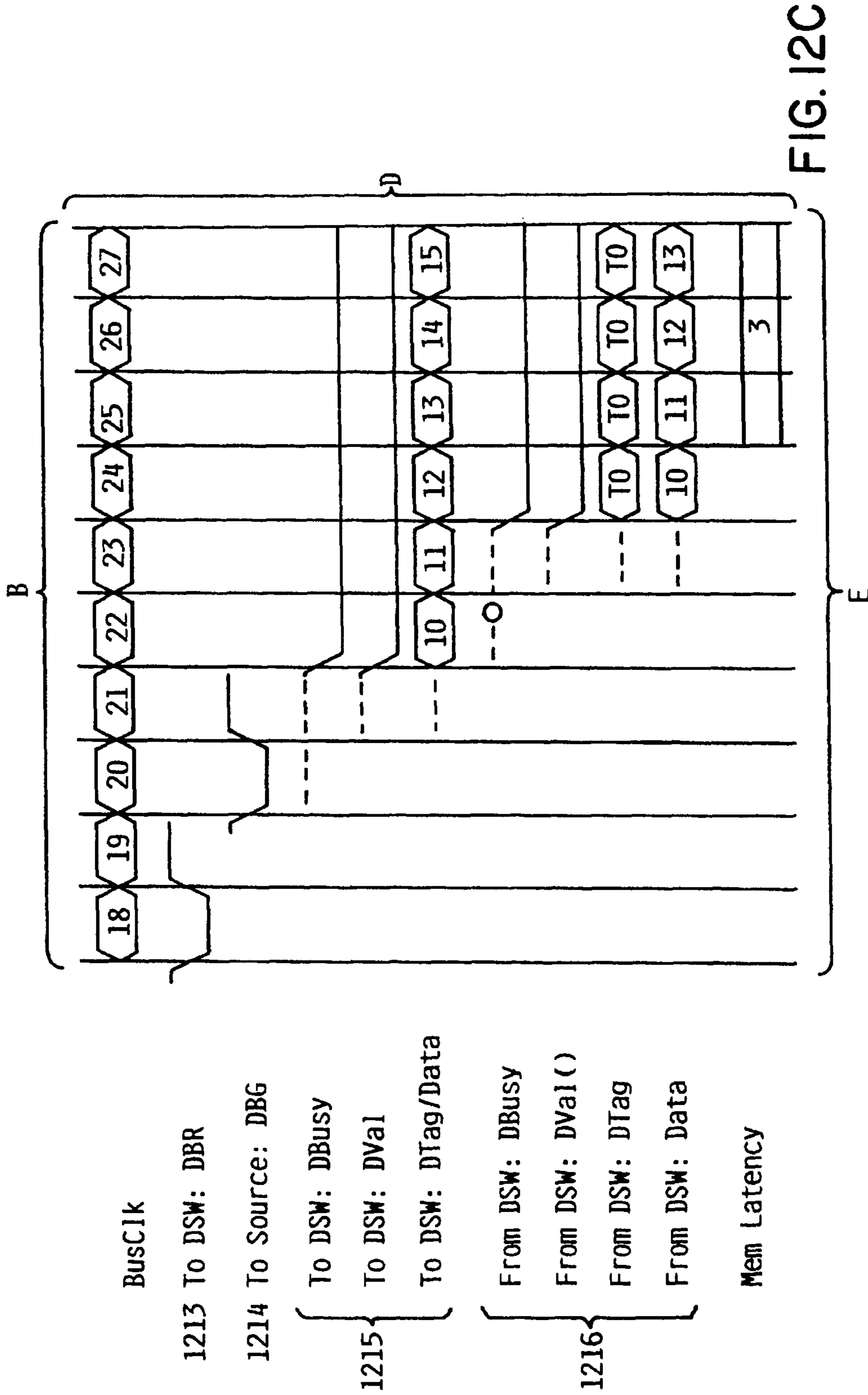

FIG. 12C

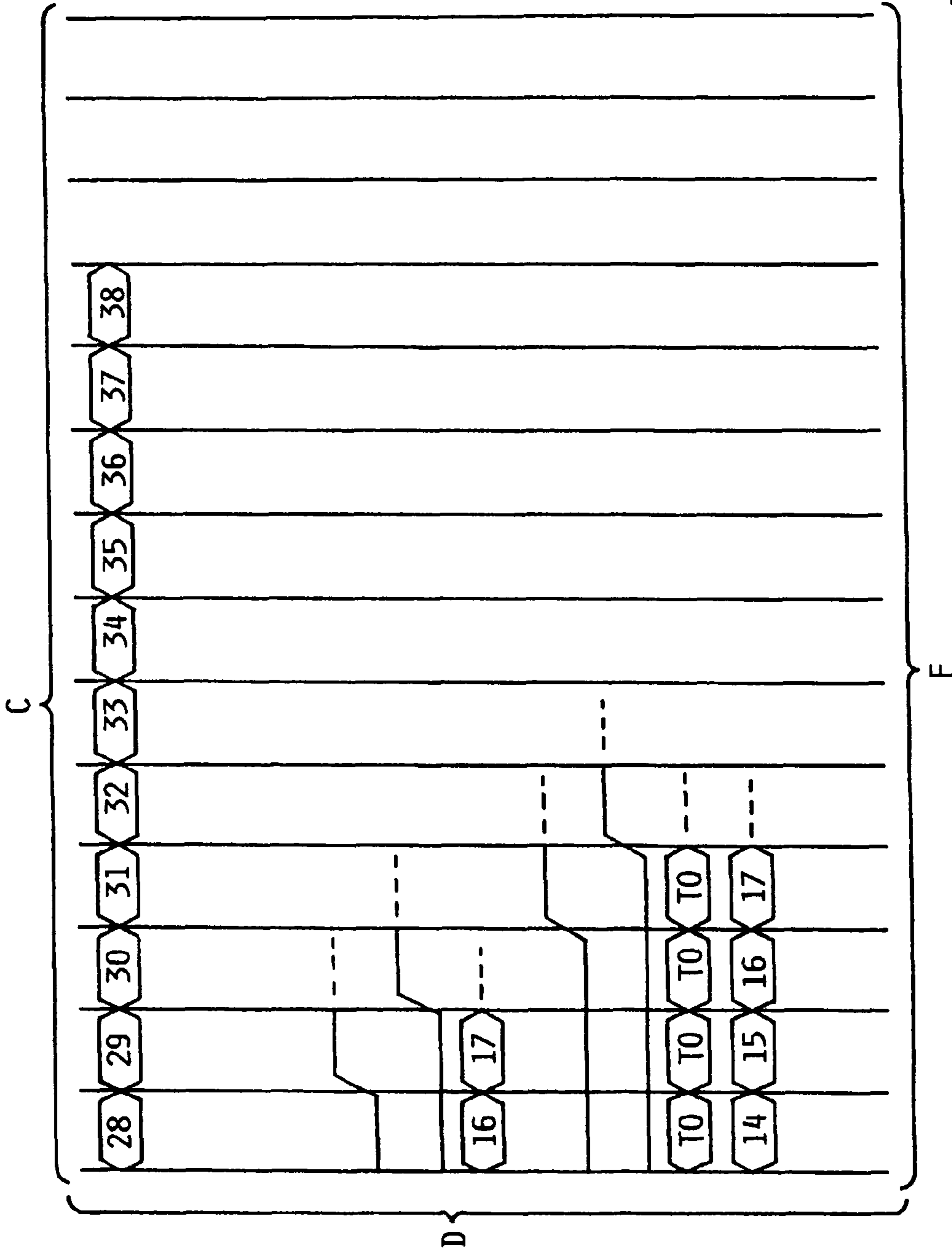

FIG. 12D

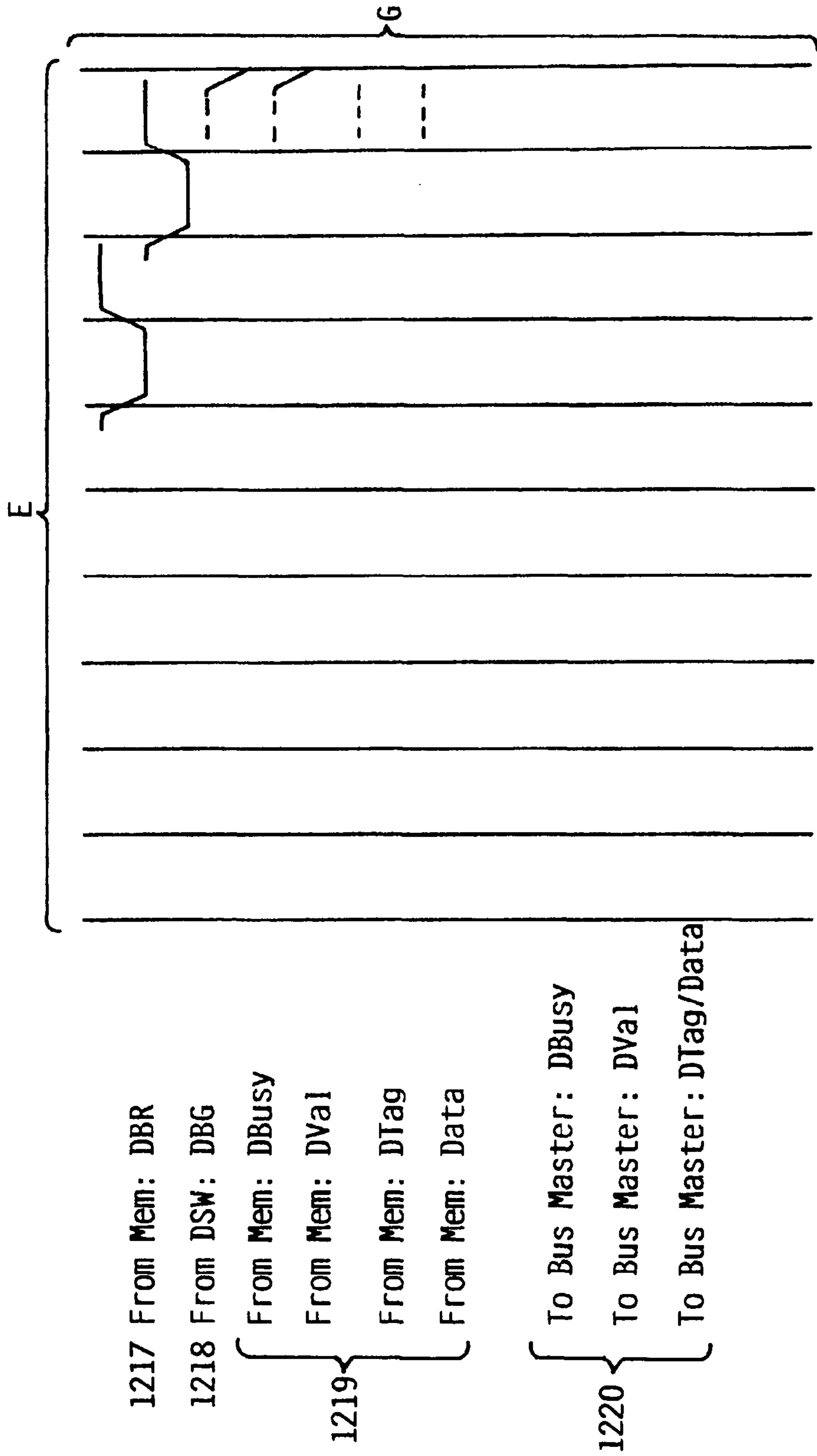

FIG. 12E

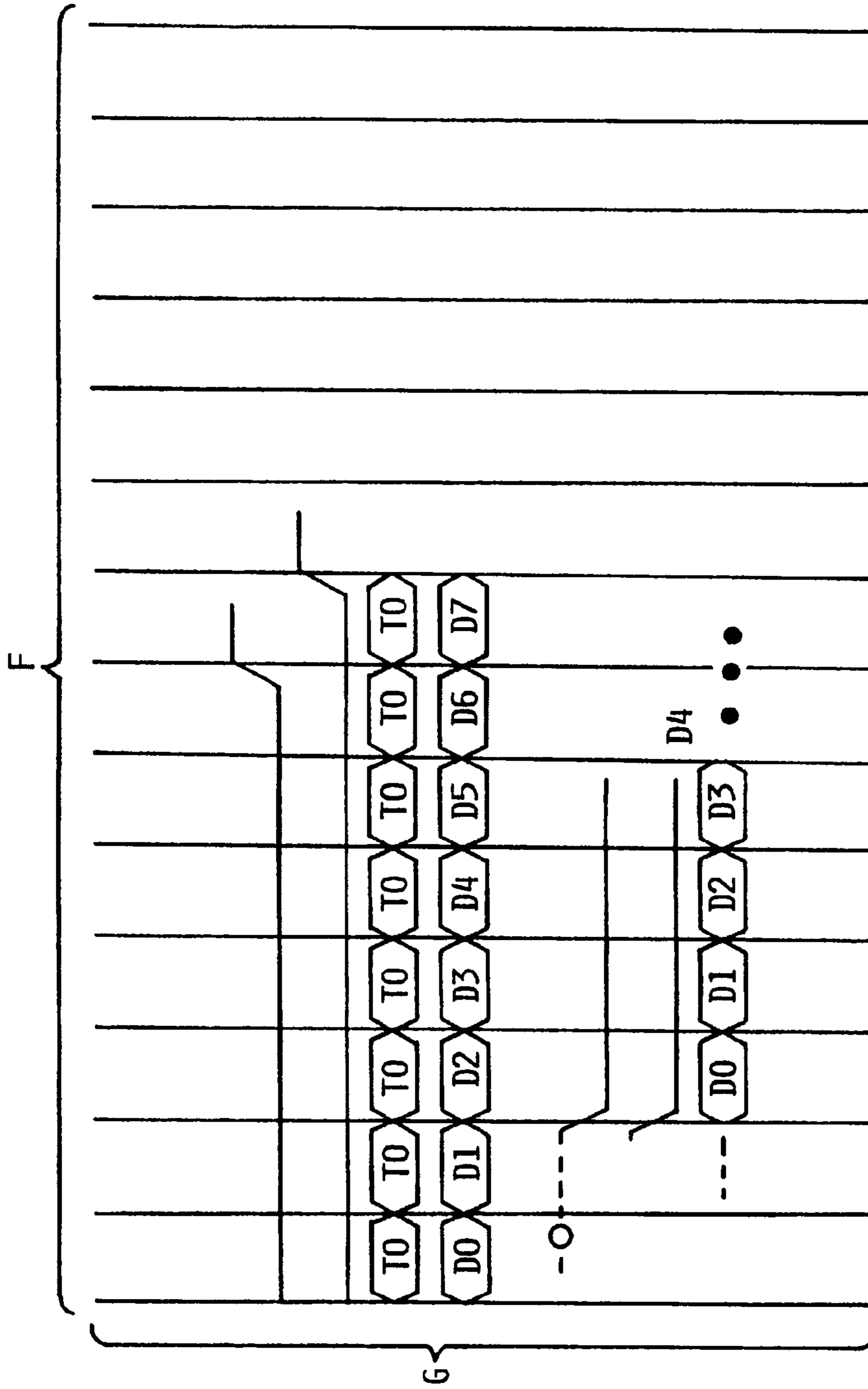

FIG. 12F

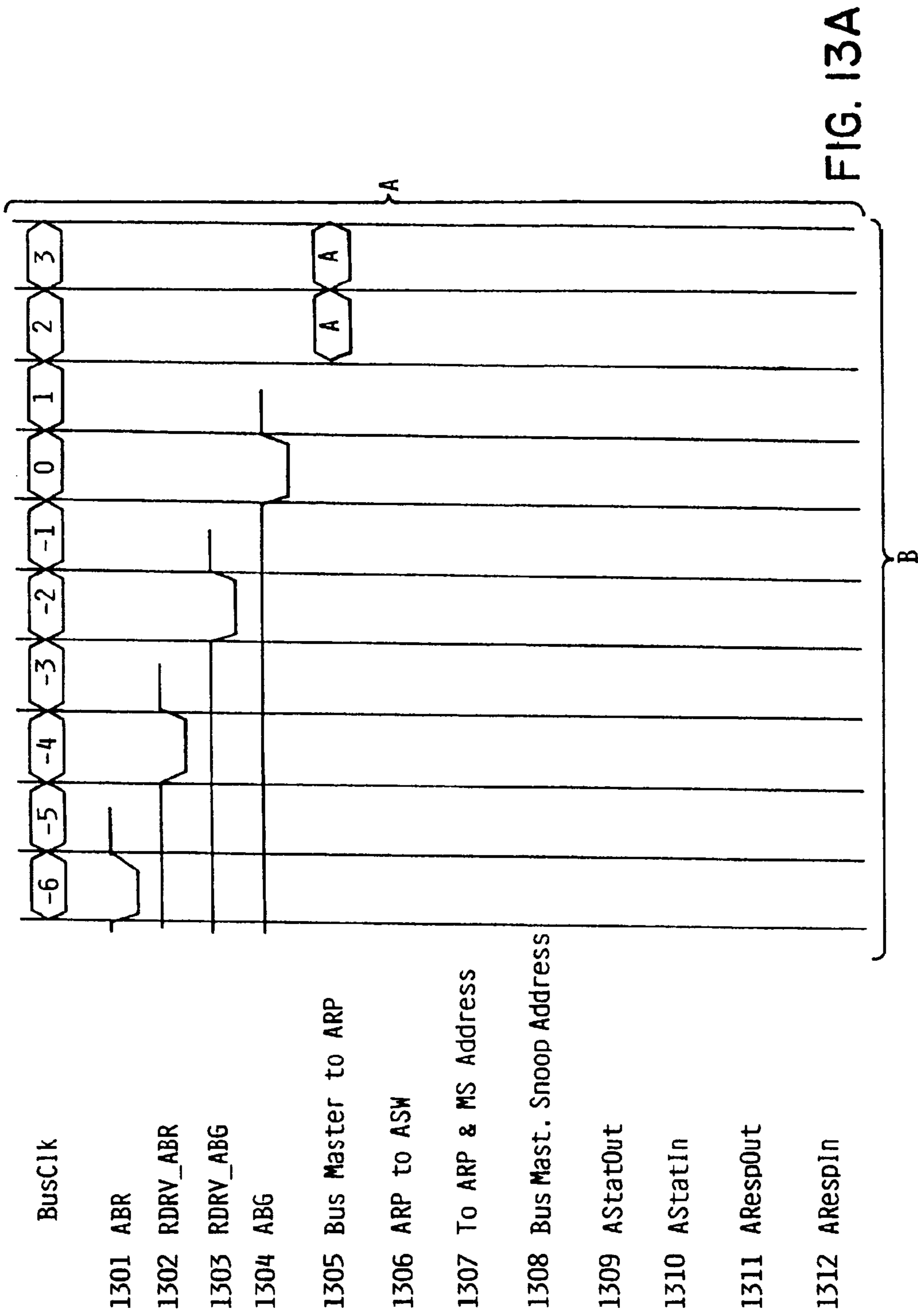

FIG. 13A

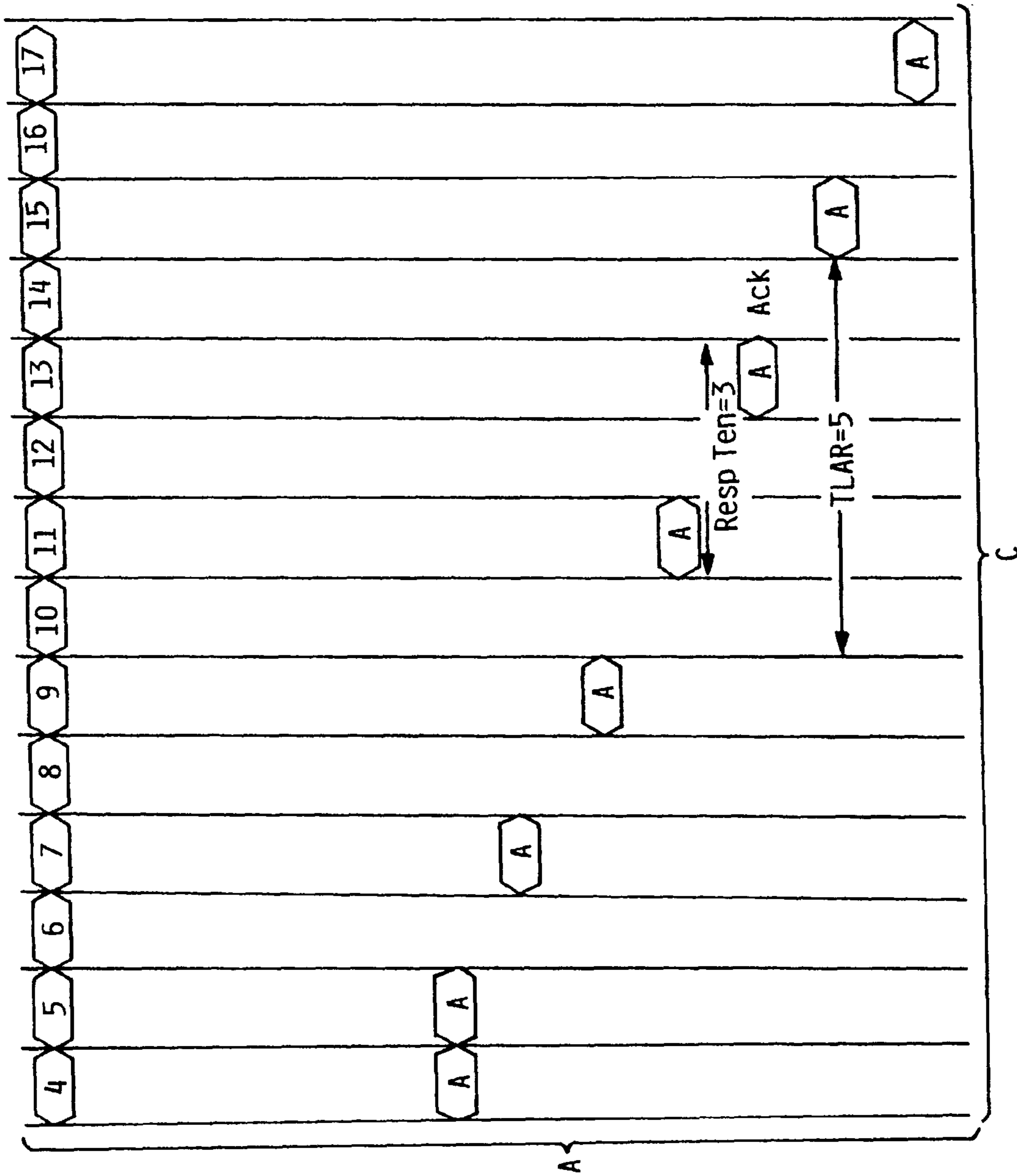

FIG. 13B

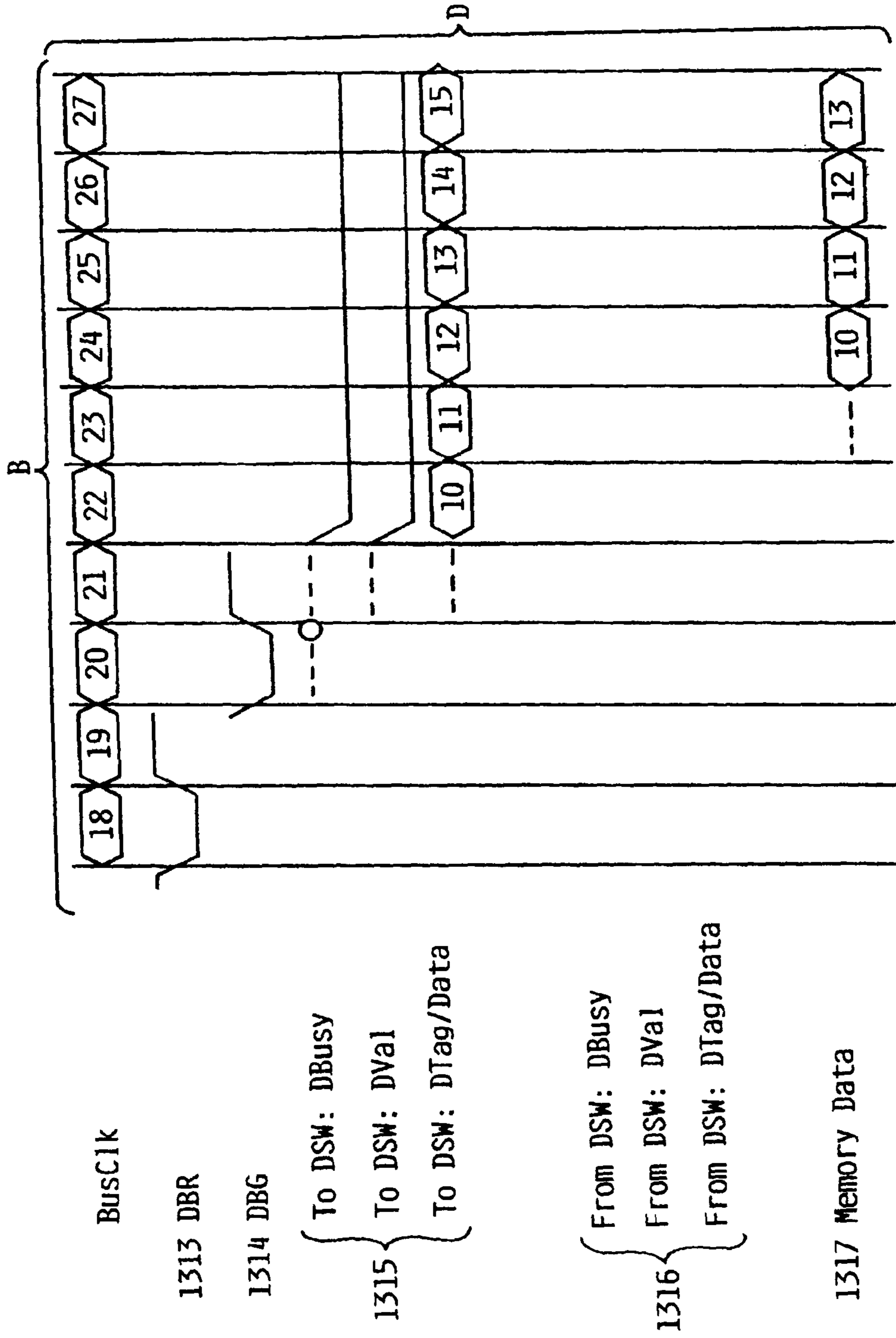

FIG. 13C

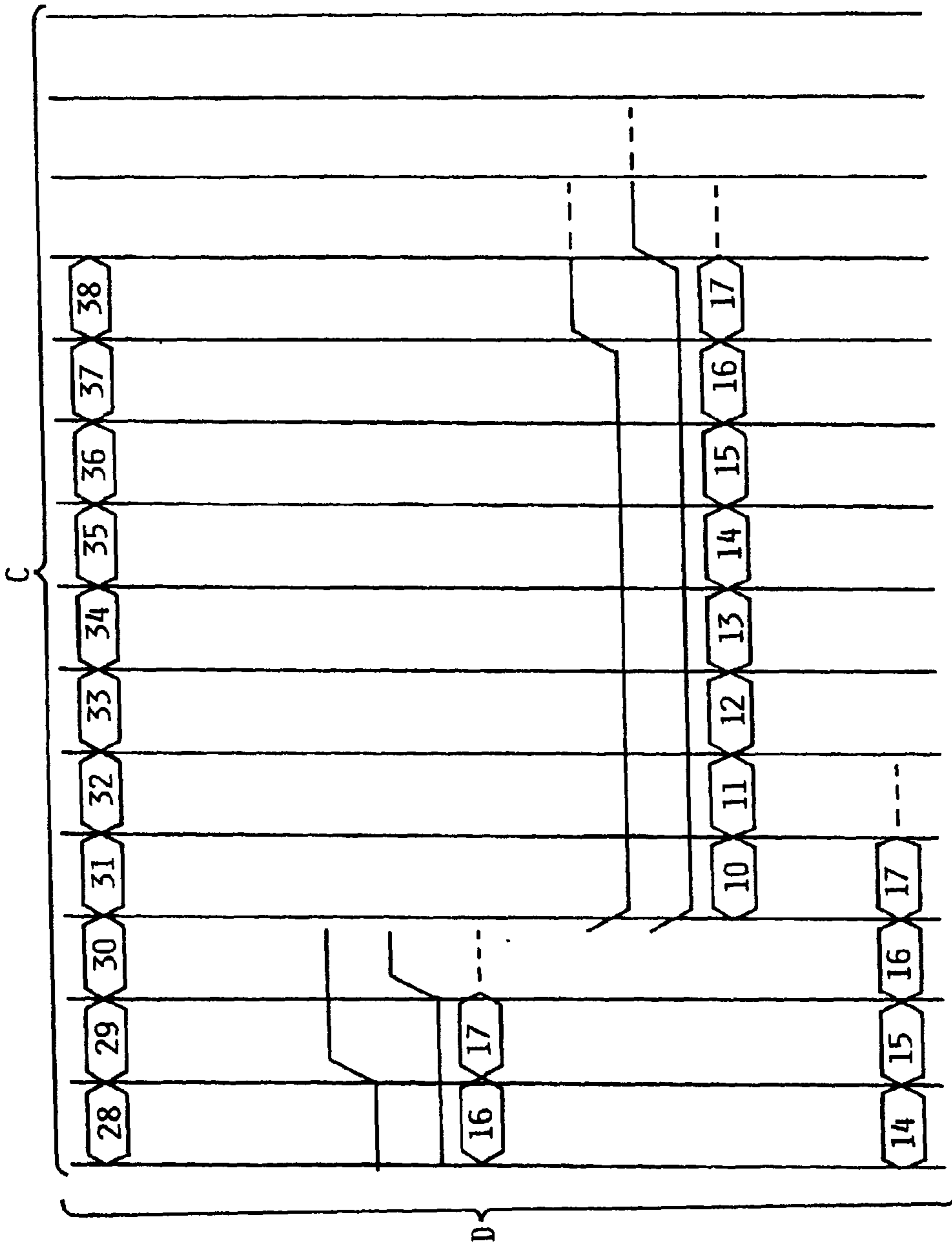

FIG. 13D

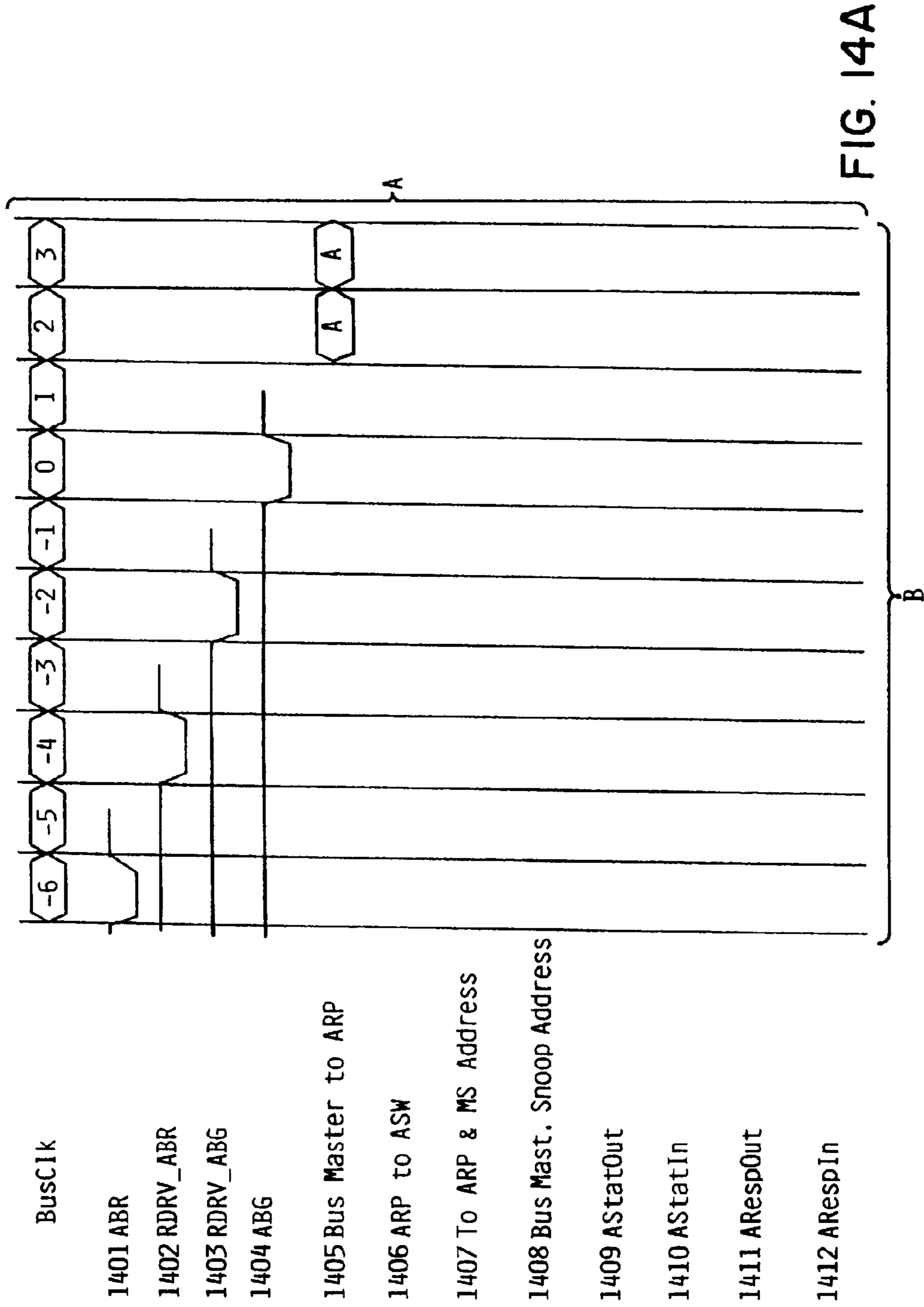

FIG. 14A

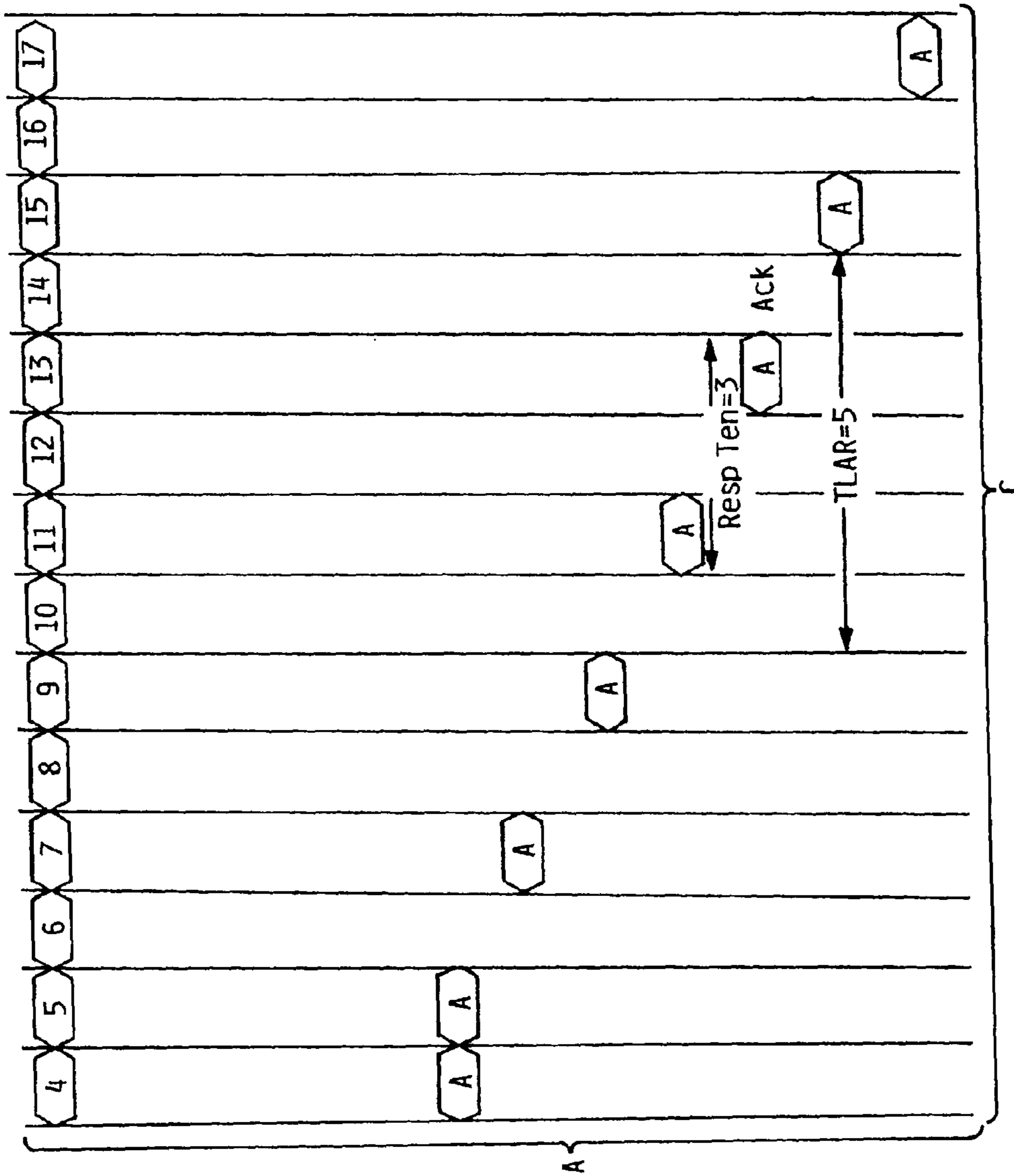

FIG. 14B

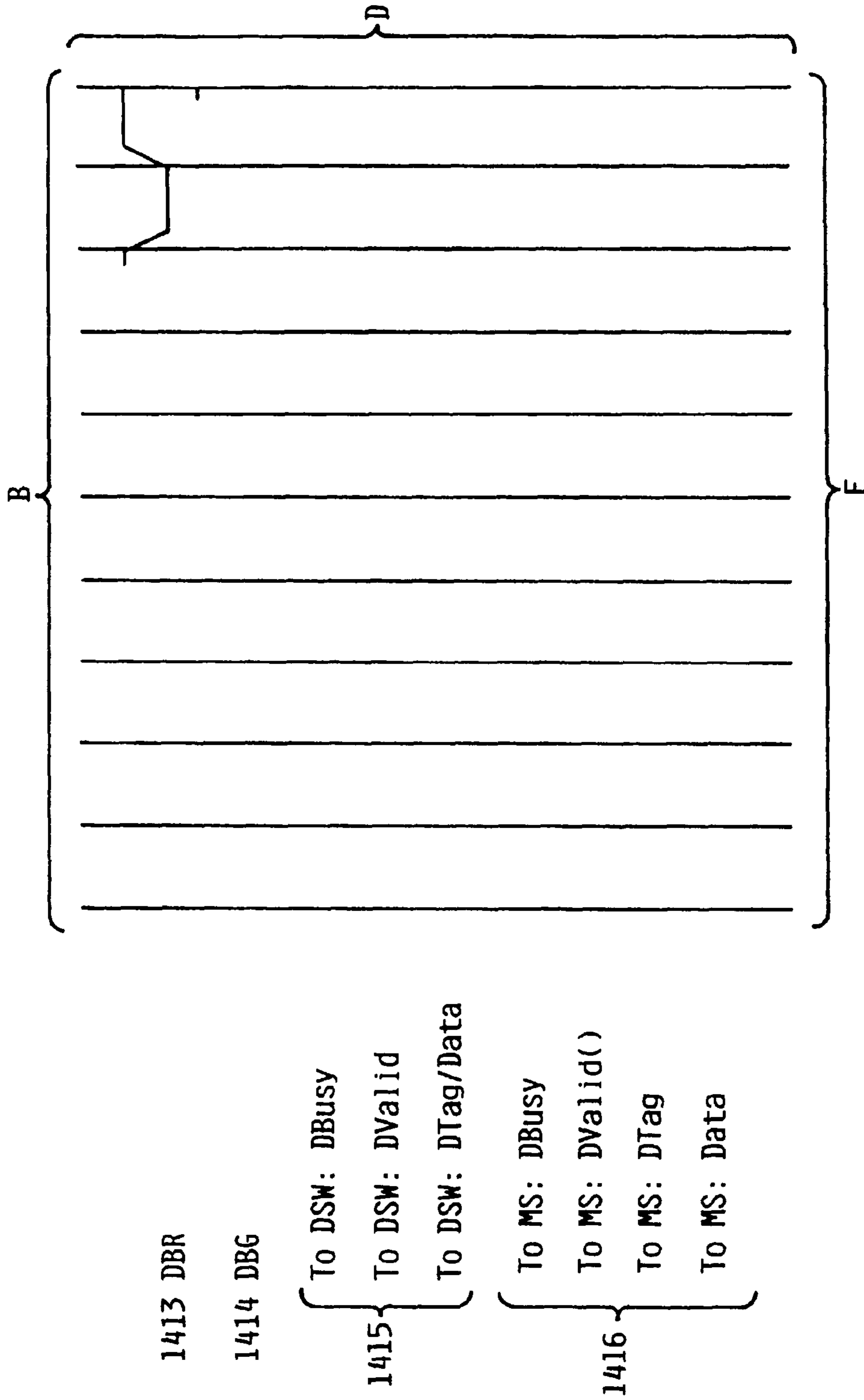

FIG. 14C

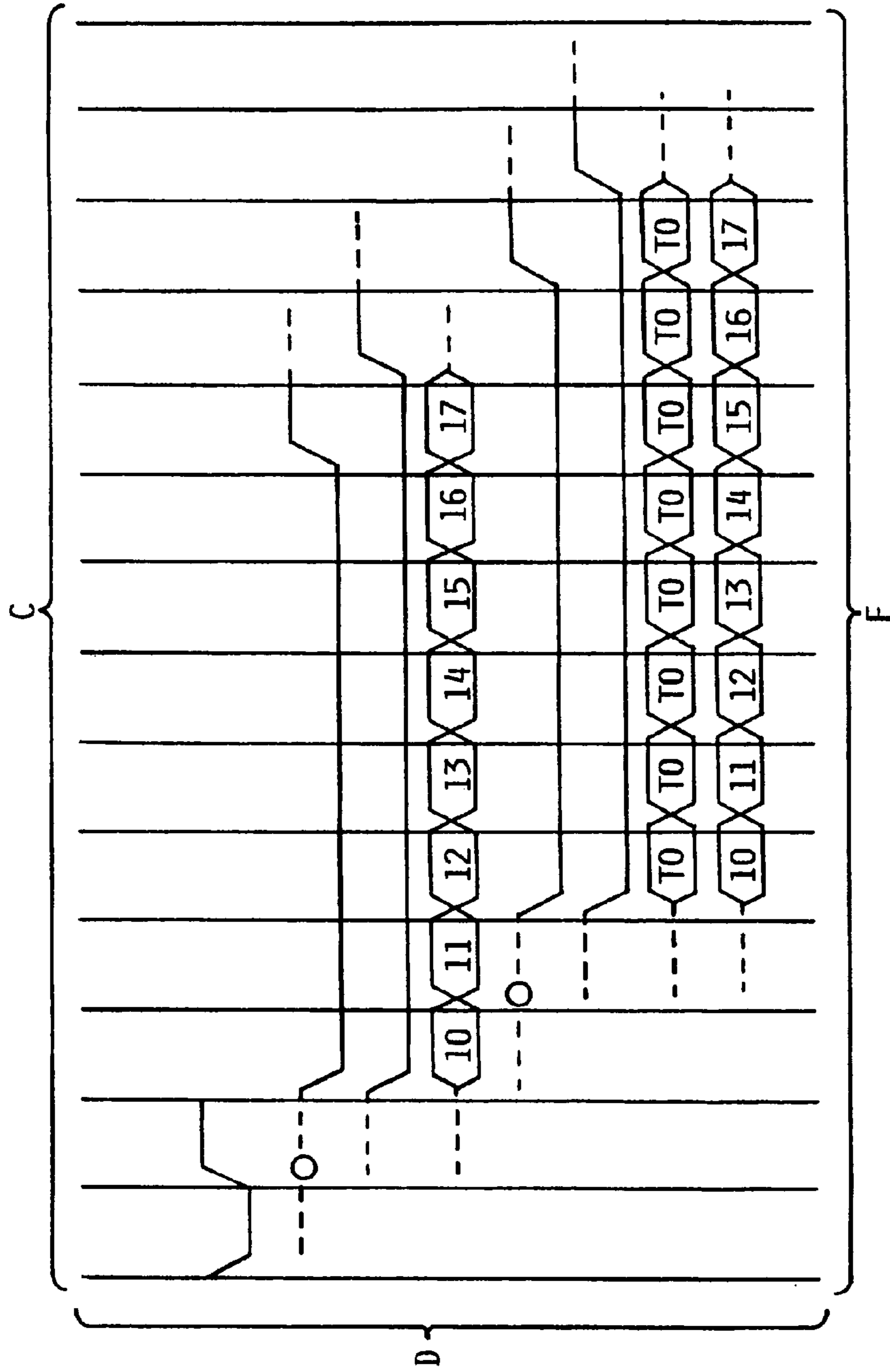

FIG. 14D

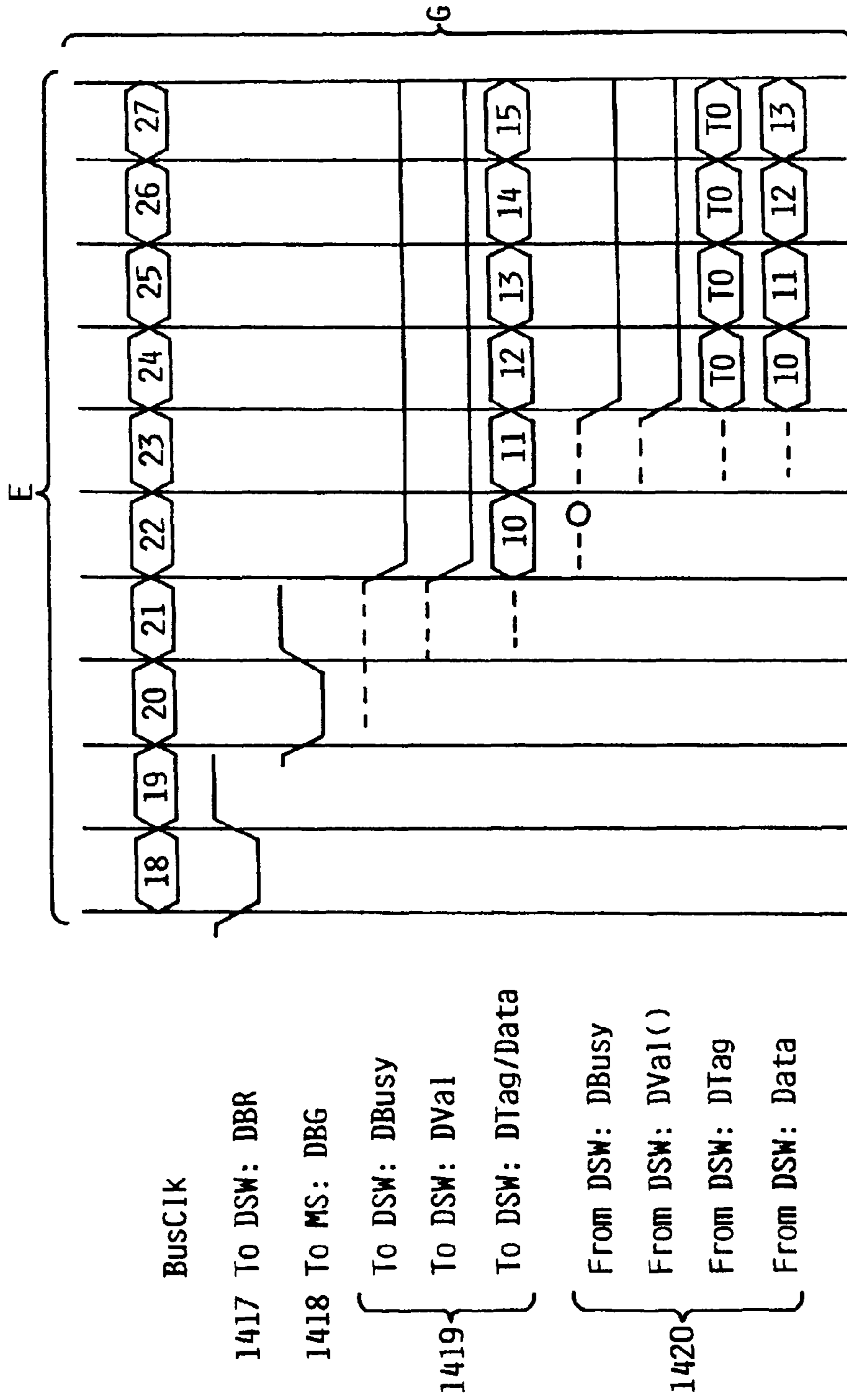

FIG. 14E

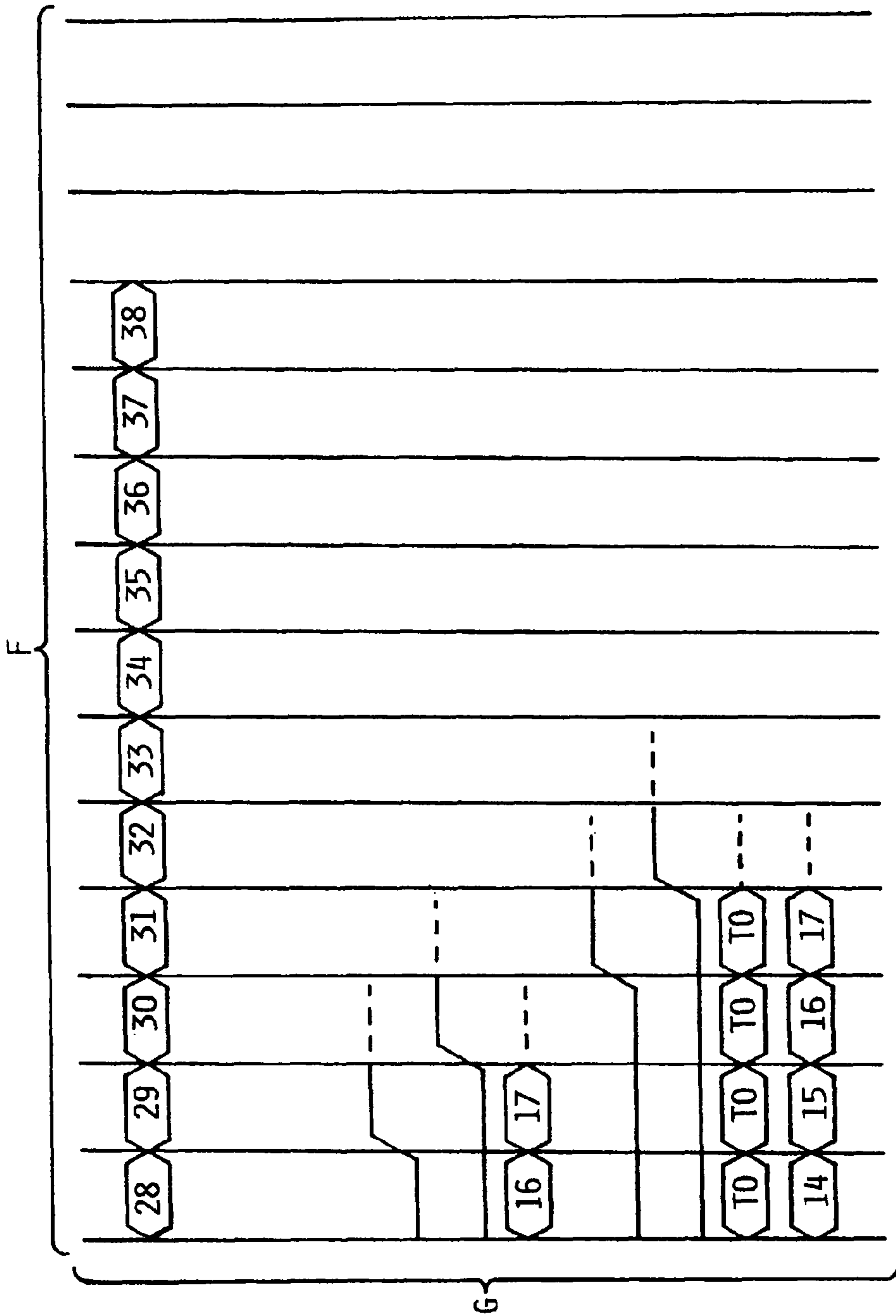

FIG. 14F

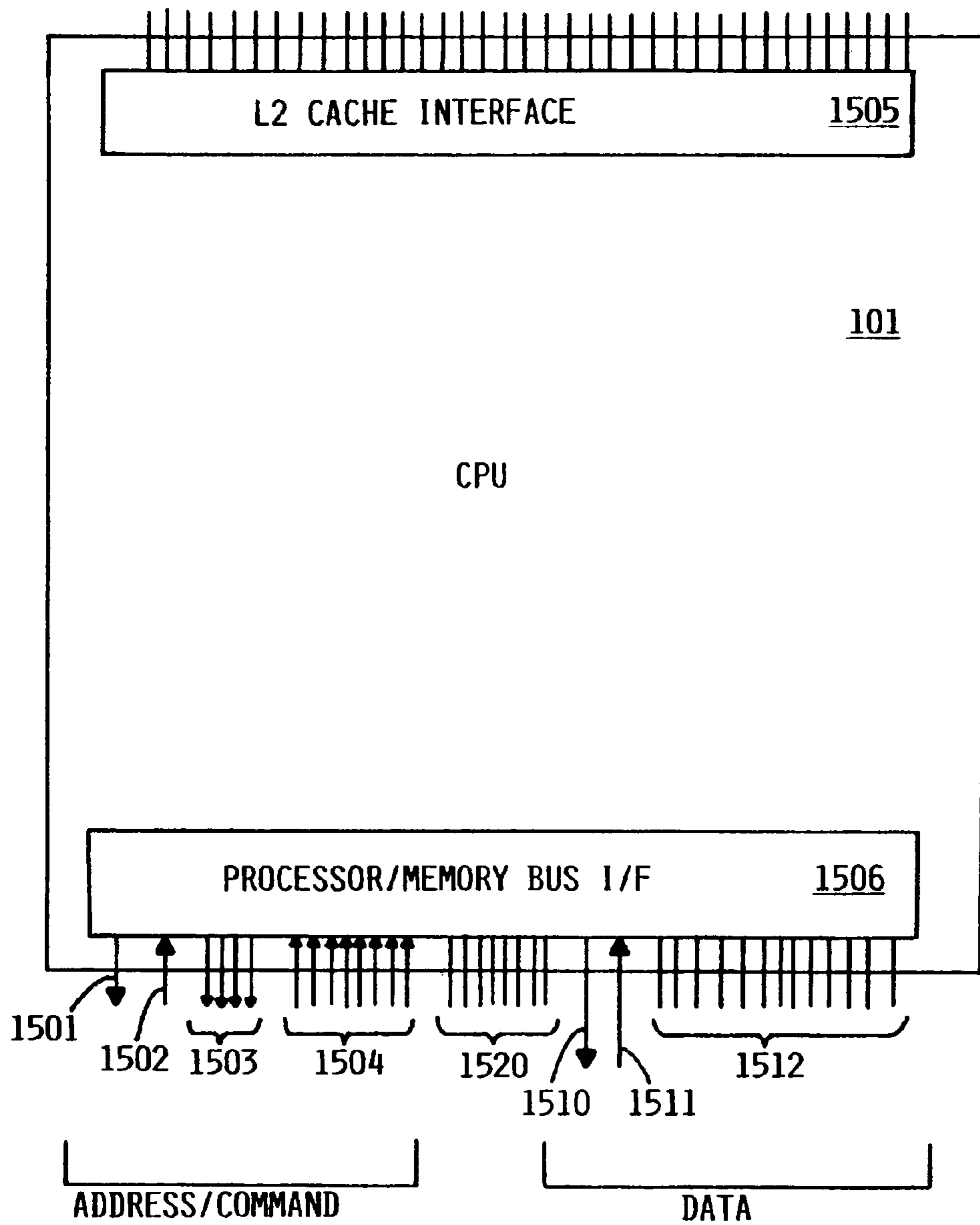

FIG. 15

**BUS ARCHITECTURE EMPLOYING
VARYING WIDTH UNI-DIRECTIONAL
COMMAND BUS**

Matter enclosed in heavy brackets [] appears in the original patent but forms no part of this reissue specification; matter printed in italics indicates the additions made by reissue.

More than one reissue application has been filed for the reissue of U.S. Pat. No. 6,526,469. The reissue applications are application Ser. Nos. 10/747,820, 11/203,652 (the present application) and 11/706,156 (filed Feb. 13, 2007 as a reissue continuation of application Ser. No. 10/747,820). The present application was filed on Aug. 15, 2005, and is a reissue divisional of application Ser. No. 10/747,820, filed on Dec. 30, 2003 as a reissue of U.S. Pat. No. 6,526,469.

CROSS-REFERENCE TO RELATED
APPLICATIONS

The present application is related to the following commonly assigned co-pending applications, filed on the same date as the present application, which are herein incorporated by reference:

Ser. No. 09/439,189, to Robert A. Drehmel, et al., entitled "Processor-Memory Bus Architecture for Supporting Multiple Processors"; and
Ser. No. 09/439,586, to H. Lee Blackmon, et al., entitled "Data Routing Using Status—Response Signals".

FIELD OF THE INVENTION

The present invention relates to digital data processing, and in particular to the design of high-speed communication buses for linking processors, memory and other components of a computer system.

BACKGROUND OF THE INVENTION

A modem computer system typically comprises a central processing unit (CPU) and supporting hardware necessary to store, retrieve and transfer information, such as communications buses and memory. It also includes hardware necessary to communicate with the outside world, such as input/output controllers or storage controllers, and devices attached thereto such as keyboards, monitors, tape drives, disk drives, communication lines coupled to a network, etc. The CPU is the heart of the system. It executes the instructions which comprise a computer program and directs the operation of the other system components.

From the standpoint of the computer's hardware, most systems operate in fundamentally the same manner. Processors are capable of performing a limited set of very simple operations, such as arithmetic, logical comparisons, and movement of data from one location to another. But each operation is performed very quickly. Programs which direct a computer to perform massive numbers of these simple operations give the illusion that the computer is doing something sophisticated. What is perceived by the user as a new or improved capability of a computer system is made possible by performing essentially the same set of very simple operations, but doing it much faster. Therefore continuing improvements to computer systems require that these systems be made ever faster.

The overall speed of a computer system (also called the throughput) may be crudely measured as the number of operations performed per unit of time. Conceptually, the simplest of all possible improvements to system speed is to increase the clock speeds of the various components, and particularly the clock speed of the processor(s). E.g., if everything runs twice as fast but otherwise works in exactly the same manner, the system will perform a given task in half the time. Early computer processors, which were constructed from many discrete components, were susceptible to significant speed improvements by shrinking component size, reducing component number, and eventually, packaging the entire processor as an integrated circuit on a single chip. The reduced size made it possible to increase clock speed of the processor, and accordingly increase system speed.

Despite the enormous improvement in speed obtained from integrated circuitry, the demand for ever faster computer systems has continued. Hardware designers have been able to obtain still further improvements in speed by greater integration (i.e., increasing the number of circuits packed onto a single chip), by further reducing the size of circuits, and by various other techniques. However, designers can see that physical size reductions can not continue indefinitely, and there are limits to their ability to continue to increase clock speeds of processors. Attention has therefore been directed to other approaches for further improvements in overall speed of the computer system.

Without changing the clock speed, it is possible to improve system throughput by using multiple processors. The modest cost of individual processors packaged on integrated circuit chips has made this approach practical. However, one does not simply double a system's throughput by going from one processor to two. The introduction of multiple processors to a system creates numerous architectural problems. For example, the multiple processors will typically share the same main memory (although each processor may have its own cache). It is therefore necessary to devise mechanisms that avoid memory access conflicts, and assure that extra copies of data in caches are tracked in a coherent fashion. Furthermore, each processor puts additional demands on the other components of the system such as storage, I/O, memory, and particularly, the communications buses that connect various components. As more processors are introduced, there is greater likelihood that processors will spend significant time waiting for some resource being used by another processor.

All of these issues and more are known by system designers, and have been addressed in one form or another. While perfect solutions are not available, improvements in this field continue to be made.

Of particular interest herein is the design of communications buses. In simple computer systems, all major components such as processor, memory, storage controllers, and I/O are connected on a single multi-drop communications bus. Physically, such a multidrop bus is a common set of parallel conductors, and each component is connected to the these conductors through logic drivers or gates. The architecture of such a bus permits any arbitrary component connected to the bus to send data to any other arbitrary component connected to the bus, although it is not necessarily the case that all possible combinations are actually used. Since only one component may send data at any time, the component sending data must first obtain control of the bus, a process known as arbitration. The bus typically has an address portion for specifying the receiving device(s), and a data portion for specifying the data being transferred. It may also have various control lines.

The clock speed at which a multi-drop bus operates is limited by the number of attached devices, their physical configuration with respect to one another, the speed at which individual devices operate, and other factors. For this reason, many computer systems have multiple buses. In particular, processors and memory may be coupled to a relatively high-speed bus, while storage and I/O devices may be coupled to a slower bus. Since processors and memory typically require a higher speed, and are physically close enough to support higher speed bus operation, isolation of processors and memory from the lower speed devices such as storage and I/O by using a special processor-memory bus supports bus operation at higher speed and improves system performance.

However, the demand for increased system throughput continues. It is desirable to increase the number of processors in a computer system to increase system throughput. However, the high-speed multi-drop processor-memory bus was intended for a relatively small number of attached components. As the number of processors attached to such a bus increases, it becomes difficult or impossible to operate the bus at the higher clock speeds necessary to support communication among the various components. Moreover, the simple creation of wider buses or of additional (parallel) buses is not always a practical solution. Wider or additional buses means that each processor must have additional I/O pins, where the number of I/O pins is already extremely constrained.

Some designers have attempted to address this problem using hierarchical buses, in which each processor is assigned to a node, all processors within a node being on the same local bus coupled to a node controller, wherein the node controller handles communications with devices in other nodes through a separate remote bus. However, these designs require a great deal of complexity on the part of the node controller, with attendant cost and collateral issues.

There is a need for an alternative high-speed communication path architecture in a computer system for supporting communication among larger numbers of processors and memory.

SUMMARY OF THE INVENTION

It is, therefore, an object of the present invention to provide an enhanced multi-processor computer system.

Another object of this invention is provide an enhanced processor-to-memory communication path for a multiprocessor computer system

Another object of this invention is to support an increased number of processors in a multiprocessor computer system.

Another object of this invention is to reduce the number of I/O pins and other hardware required to support communications in a multiprocessor system.

An internal communication network for supporting data communication among multiple processors and memory within a computer system comprises a command portion for transmitting addresses and commands, having a unidirectional input bus portion for transmitting commands to a central command repeater unit, and a unidirectional broadcast bus portion for broadcasting commands from the central command repeater unit. The input portion comprises a plurality of links running from different devices, wherein each link is less than the full width of the broadcast bus portion. A command is transmitted over the input portion in a plurality of bus cycles, and broadcast over the broadcast portion in a single bus cycle. Since multiple input links connect to the central command repeater, it is possible to keep the broadcast

bus full notwithstanding the fact that multiple bus cycles are required to transmit an individual command on the input portion.

In the preferred embodiment, the links are arranged hierarchically. A series of unidirectional links runs between processors and local address repeater units (ARPs), and between the ARPs and the central command repeater, called an address switch unit (ASW), all of these links being half-width. A data transfer command propagates from a requesting device to its local ARP, to the ASW, requiring two bus cycles for each stage. From the ASW, the command is broadcast to all component devices on the network in a single bus cycle by transmitting to all ARPs or directly attached memory on a separate set of full-width unidirectional links. The ARPs then repeat the transmission to all attached processors or other units on another set of unidirectional links.

In the preferred embodiment, the ASW globally arbitrates the command bus. A request by a processor to transmit an address to the ARP must be granted first by the ASW. Once granted, the command will propagate in a pre-defined number of clock cycles to the ASW through the ARP, and thus addresses are not buffered in the ARP (although they are held in a register for a small number of cycles during re-propagation). The command is then broadcast, again at pre-defined bus cycles from initial bus grant.

In the preferred embodiment, addresses/commands and data are transmitted on essentially separate paths having different topologies, and at different times, and are arbitrated separately. The data portion of the network comprises a set of bidirectional links from the processors to a local data switch unit (DSW). The local DSW is further linked directly to memory via bi-directional links. In fact, the data portion of the network contains multiple independent data paths supporting multiple simultaneous data transfers, all of which are supported by a single logical hierarchical address bus portion. No address is transmitted with the data; rather, a tag is transmitted which identifies the command with which the data is associated.

Consistent with commonly understood terminology, the network is herein referred to collectively as a "bus" or "memory bus" (the latter to distinguish it from I/O buses). The portion of the network which transmits addresses and commands is sometimes referred to as the "address bus", while the data portion is referred to as the "data bus", and other portions of the network are similarly designated. It will be understood that the communications network described herein is not physically the same as a classical multi-drop bus, although it performs the analogous function.

The bus described herein acts has characteristics of a pipeline, wherein high clock speed (and high throughput) is achieved by staging bus operations over a number of cycles. The full-width broadcast bus is kept full because multiple commands can be received by the central repeater in an overlapping fashion on the multiple input links. The use of multiple hierarchical links enables the entire memory bus to operate at high clock speed. Furthermore, because the repeaters and ASW do not buffer data or determine destination through complex directories, the design is greatly simplified vis-a-vis typical prior art hierarchical designs. All of these considerations make it possible to support a relatively large number of processors at a high throughput.

The details of the present invention, both as to its structure and operation, can best be understood in reference to the accompanying drawings, in which like reference numerals refer to like parts, and in which:

5

BRIEF DESCRIPTION OF THE DRAWING

FIG. 1 shows the major hardware components of a multi-processor computer system for utilizing the high speed memory bus architecture according to the preferred embodiment of the present invention.

FIG. 2 shows in greater detail the overall topology of the memory bus, according to the preferred embodiment.

FIG. 3 shows in greater detail the components of the address bus portion of the memory bus, according to the preferred embodiment.

FIG. 4 shows in greater detail the components of the status bus portion of the memory bus, according to the preferred embodiment.

FIG. 5 shows in greater detail the components of the response bus portion of the memory bus, according to the preferred embodiment.

FIG. 6 shows in greater detail the data bus portion of the memory bus, in accordance with the preferred embodiment.

FIG. 7 shows in greater detail the components which support arbitration of the memory bus, according to the preferred embodiment.

FIG. 8 is a timing diagram of bus activity for a command-only bus transmission, according to the preferred embodiment.

FIG. 9 is a timing diagram of bus activity for a read-from-memory bus transmission, according to the preferred embodiment.

FIG. 10 is a timing diagram of bus activity for a write-to-memory bus transmission, according to the preferred embodiment.

FIG. 11 is a timing diagram of bus activity for a read-from-device, where the data source and bus master are in the same local node but not on the same local data bus, according to the preferred embodiment.

FIG. 12 is a timing diagram of bus activity for a read-from-device, where the data source and bus master are in different local nodes, according to the preferred embodiment.

FIG. 13 is a timing diagram of bus activity for a read-from-device, where the data source and bus master are on the same local bus, according to the preferred embodiment.

FIG. 14 is a timing diagram of bus activity for a write-to-device, according to the preferred embodiment.

FIG. 15 illustrates a processor chip and its I/O pin requirements at a high level, according to the preferred embodiment.

DETAILED DESCRIPTION OF THE PREFERRED EMBODIMENT

The major hardware components of a multiprocessor computer system 100 for utilizing the high speed memory bus architecture according to the preferred embodiment of the present invention are shown in FIG. 1. Multiple central processing units (CPUs) 101A, 101B and 101C perform basic machine processing function on instructions and data from main memory 102. Each processor contains or controls a respective cache. In the preferred embodiment, each processor has a separate on-chip L1 instruction cache, an on-chip L1 data cache, and an on-chip L2 cache directory/controller, the L2 cache itself being in a separate chip. However, these cache structures are shown conceptually in FIG. 1 as a single block 106A, 106B and 106C for each respective processor. For purposes of this invention, the precise implementation details of caching in each processor are not significant, and the caches could be implemented differently.

I/O bus interface units 105A, 105B communicate with multiple I/O processing units (IOPs) 111-117 through respec-

6

tive system I/O buses 110A, 110B. In the preferred embodiment, each system I/O bus is an industry standard PCI bus. The IOPs support communication with a variety of storage and I/O devices, such as direct access storage devices (DASD), tape drives, workstations, printers, and remote communications lines for communication with remote devices or other computer systems. While three CPUs, two I/O bus interface units and I/O buses, and various numbers of IOPs and other devices are shown in FIG. 1, it should be understood that FIG. 1 is intended only as an illustration of the possible types of devices that may be supported, and the actual number and configuration of CPUs, buses, and various other units may vary. For simplicity, CPUs, bus interface units, and system I/O buses are herein designated generically by reference numbers 101, 105 and 110, respectively.

In FIG. 1, feature 103 conceptually represents a memory bus for communicating among the various processors 101, memory 102 and I/O interface units 105. Clearly, some form of communication path is required for multi-processor computer system 100 to function. This function could theoretically be performed (although not necessarily at acceptable performance levels) using a single multi-drop bus connected to all the processors, memory, and I/O interface units. The present invention is directed toward providing essentially this function at improved performance.

In the preferred embodiment, computer system 100 is an IBM AS/400 multiprocessor computer system, it being understood that the present invention could be implemented on other multiprocessor computer systems.

FIG. 2 shows in greater detail the overall topology of memory bus 103. Processors 101A-101H are mounted on electronic circuit cards 201A-201D (herein generically referred to as reference number 201), each card defining a separate local node. Each card 201 can hold up to eight processors 101, although cards will not necessarily always have the architectural maximum number of processors. Each card 201 also contains an address repeater unit (ARP) 210 and a data switch unit (DSW) 211. In the preferred embodiment, data switch unit 211 is implemented on two chips (hence the depiction in FIG. 2), but it acts as a single functional unit, as described herein. Local address bus links (i.e., contained entirely within card 201) connect each processor 101 with the ARP unit 210 in its card, while local data bus links connect each processor 101 with the DSW unit 211 in its card. These are described more fully below.

In addition to one or more processor cards 201, each containing multiple processors, the system will typically contain one or more I/O cards 202. Each I/O card is also a separate local node in the memory bus network, and contains up to four I/O bus interface units 105A-105D, each unit communicating (through adapter hardware, not shown) with a respective PCI bus 110A-110D. As in the case of processor cards, each I/O card 202 will not necessarily contain the architected maximum number of interface units 105. Each I/O card 202 similarly contains an ARP unit 210 and a DSW unit 211, the I/O bus interface units 105 being coupled to ARP 210 by local address bus links, and being coupled to DSW 211 by local data bus links, as described more fully herein.

Main memory 102 is contained in one or two memory subsystems 203A-203B (herein generically referred to as reference number 203), each subsystem having separate physical packaging (i.e., each subsystem may be on one or more separate cards or assemblies of cards. Each subsystem is also another local node from the perspective of the memory bus, although the memory subsystem nodes function somewhat differently from processor and I/O interface nodes. The memory controller card contains a memory address interface

(MAI) unit **220** and a memory data interface (MDI) unit **221** (the latter being implemented in the preferred embodiment and depicted in FIG. 2 as four chips, but functionally a single unit). The memory address interface unit **220** receives addresses on the memory bus and routes address signals to physical memory. Data interface unit **221** handles communication of data between the memory bus and physical memory devices. The two memory subsystems are configured so that the identity of the memory subsystem storing a particular data address is derivable from the address itself, e.g., by taking a single bit of the address. This assists data routing for various bus operations.

All ARP units **210** and memory address interface units **220** are coupled via remote links to a single central address repeater unit (also referred to as the address switch, or ASW) **212** (depicted in FIG. 2 as two chips, but functionally a single unit). These links are "remote" in the sense that they are go from card to card (intercard links). ASW **212** propagates addresses among local nodes and handles global memory bus arbitration.

A global clock signal **215** is distributed to all nodes and to ASW **212**. All memory bus activity is synchronized to this global signal.

FIG. 3 shows in greater detail the components of the address bus portion of memory bus **103**. The address bus portion transmits a destination address, a command code, a tag, and some miscellaneous bits, and although it contains information other than the address, it is designated simply the "address bus" for convenience. Each processor card **201** contains two unidirectional local address request buses **301A-301B** (herein generically referred to as reference number **301**) running from processors **101** to ARP **210**, each local address request bus **301** supporting up to four processors. Each local address bus **301** is physically a shared set of parallel lines, the number of lines being one-half that required to transmit a complete address along with associated command, tag, parity and other control information. I.e., unidirectional local address request buses **301** are half-width, two bus cycles being required to transfer a complete address and associated information. Since the bus is shared, only one processor can transmit in any given cycle. The I/O card **202** is similar, but each local address bus **301** supports two I/O interface units **105**.

A single unidirectional remote address request bus **302A** (herein generically referred to as reference number **302**) runs from ARP **210** to ASW **212**. There is a separate bus **302** from each ARP **210** to ASW **212** (including ARP **210** in I/O node card **202**), requiring a separate port (separate set of input pins) for each bus **302**. Like bus **301**, each bus **302** is half-width, and requires two bus cycles to transmit a full address along with associated control information.

ARP **210** has no buffering capability. The addresses received on buses **301** are held in repeater registers for two cycles, but APR **210** can not otherwise hold address information received on bus **301**. Therefore, only one of buses **301** within a card **201** can transmit to the ARP **210** at any one time. ASW **212** grants the right to transmit to a processor **101** (or I/O interface unit **105**), and ARP **210** simply gates the appropriate one of buses **301** into its repeater registers for transmission to ASW **212** on remote address request bus **302**.

A single respective unidirectional remote address broadcast bus **303A** (herein referred to generically as reference number **303**) runs from ASW **212** to each ARP **210**. This bus is used to transmit all addresses received by ASW **212** to the various local nodes, i.e., address requests received by ASW **212** are broadcast to all the local nodes. Unlike request bus

302, broadcast bus **303** is full width, capable of transmitting the entire address and associated control information in a single bus cycle.

A set of four unidirectional local address broadcast buses **304A-304D** (herein generically referred to as reference number **304**) runs from ARP **210** to the processors **101** (or, in the case of an I/O card **202**, to I/O bus interface units **105**, not shown). These buses are used to broadcast addresses received by ARP **210** from ASW **212** on bus **303**. ARP **210** makes no decisions as to which processor(s) or bus interface unit(s) will receive the addresses; it simply broadcasts any address coming in on bus **303** to all devices in its local node (card). Since remote broadcast bus is **303** is full width, it follows that local broadcast buses **304** must also be full width. While connections to only one node **201** are shown in FIG. 3, it will be understood that these connections are repeated for each node, the additional connections being omitted from the figure for clarity of illustration.

A single unidirectional memory address broadcast bus **305** runs directly from ASW **212** to memory address interface units **220** in each of the memory subsystems **203**. Bus **305** acts like bus **303**, broadcasting addresses and associated control information to the memory subsystems. Memory address interface units **220** further propagate this information within the memory subsystems **203**, but for purposes of understanding memory bus **103**, it is not necessary to describe the memory subsystem architecture in detail here. Bus **305** is also a full width bus, carrying all the address and associated information in a single bus cycle.

It will be observed that ASW **212** contains five ports receiving up to five separate half-width remote address request buses **302** from up to five separate nodes **201**. ASW **212** can receive addresses from more than one node simultaneously. In fact, it is intended that it do so. Addresses received on buses **302** are half-width, being received in two separate clock cycles, while addresses transmitted out on buses **303** and **305** are full width, being transmitted in a single cycle. In order to utilize buses **303** and **305** to full capacity, addresses from separate nodes are received in overlapping concurrent fashion by ASW **212** on the half-width buses **302**.

The use of half-width buses **301**, **302** rather than full width saves precious I/O pins on the processor, ARP and ASW chips. In theory, if one assumes that all nodes make an equal number of requests, the address request buses can be 1/N the width of the broadcast bus **303**, where N is the number of nodes which can request use of the memory bus. In the present architecture, a half-width (N=2) is chosen, because the number of nodes will vary depending on customer configuration, and it is difficult to guarantee that nodes will submit an equal number of requests. However, the bus width can vary, and in particular, if the present architectural concepts are applied to a system having a larger number of nodes and processors, request buses of $\frac{1}{3}$ width, $\frac{1}{4}$ width, or smaller may be appropriate.

FIG. 4 shows in greater detail the components of the status bus portion of memory bus **103**. The status bus comprises multiple unidirectional point-to-point links running directly between processors **101** or I/O bus interfaces units **105** and ASW **212**. I.e., these links by-pass ARP **210**. Particularly, a separate unidirectional send status link **401A-401B** (herein referred to generically as reference number **401**) runs from each processor **101** (or I/O bus interface unit **105**, not shown) to a respective input port on ASW **212**. A separate unidirectional receive status link **402A-402B** (herein generically referred to as reference number **402**) runs from a respective output port on ASW **212** to each respective processor **101** (or I/O bus interface unit **105**, not shown). Each unidirectional

point-to-point link **401** or **402** is physically two parallel line (not including a parity line, which is a combined parity line for the status and response buses). While connections to only two processors are shown in FIG. 4, it will be understood that these connections are repeated, the multiple connections being omitted from the figure for clarity of illustration.

Additionally, a separate point-to-point send status link **403A-403B** (herein generically referred to as reference number **403**) runs from each memory subsystem **203** to a respective port on ASW **212**. A separate point-to-point link **404A-404B** (herein generically referred to as reference number **404**) runs from a respective port on ASW **212** to each memory subsystem **203**, links **403** and **404** containing the same two parallel lines as links **401** and **402**.

The two lines of the status bus are sufficient to specify one of four possible status states, each having an associated priority, from Table 1 below:

TABLE 1

Priority	Status
1	Address Parity Error
2	Retry
3	Address Acknowledge
4	Null (not decoded, no parity error, no retry)

The lower number indicates a higher priority. The ASW collects status received from all devices, and broadcasts the highest priority status received. Thus, an address parity error, indicating a severe hardware fault, has the highest priority and will automatically be broadcast in preference to any other response. This will usually abort processing and trigger some machine check condition. A retry indicates that a device has not had time to determine whether the command is intended for it, e.g., a processor has not had time to look in its cache to determine whether it has a copy of the data. Because the bus architecture operates on a pipeline paradigm, all devices must respond on a pre-defined bus cycle, whether they have had time to determine the correct response or not. Understandably, in some cases a processor may be so busy with other high priority tasks that it can not make the required determination, but the need to respond dictates that it request a retry of the command. An address acknowledge is the response when a device determines that the command is applicable to it, e.g., it has a copy of the requested data, although not necessarily the only copy. A device responds with null if the command is not applicable to the responding device.

FIG. 5 shows in greater detail the components of the response bus portion of memory bus **103**. The response bus is similar to the status bus, and comprises multiple unidirectional point-to-point links running directly between processors **101** or I/O bus interface units **105** and ASW **212**, bypassing ARP **210**. A separate unidirectional send response link **501A-501B** (herein generically referred to as reference number **501**) runs from each processor **101** (or I/O bus interface unit **105**, not shown) to a respective input port on ASW **212**. A separate unidirectional receive response link **502A-502B** (herein generically referred to as reference number **502**) runs from a respective output port on ASW **212** to each respective processor **101** (or I/O bus interface unit **105**, not shown). Each unidirectional point-to-point link **501** or **502** is physically three parallel lines (not including parity). While connections to only two processors are shown in FIG. 5, it will be understood that these connections are repeated, the multiple connections being omitted from the figure for clarity of illustration. Additionally, a separate point-to-point receive response link **504A-504B** (herein generically referred to as

reference number **504**) runs from the ASW to each memory subsystem **203**, also containing three lines. There is no send response link running from the memory subsystems to the ASW, since the memory subsystems generate only status, not responses.

The three lines of the response bus are sufficient to specify one of up to eight responses, each having an associated priority (lower number being highest). However, not all eight possibilities are used. The responses used in the preferred embodiment are listed in Table 2 below:

TABLE 2

Priority	Response
1	Retry
2	Modified-Intervention
3	Shared-Intervention
4	Rerun
5	Shared
6	Null or Clean (Not Modified or Shared)

The ASW collects responses received from all devices, and broadcasts the highest priority response received. A retry indicates that the device may have modified data, but has not had time to determine this. Modified-intervention means that the responding device has modified data in its cache; this has a relatively high priority, because only the modified data should be used. Shared-intervention means that the responding device has a shared but unmodified copy of data in its cache, which should be used instead of the copy from memory. The shared-intervention response is optionally enabled, depending upon system configuration, and location of the responding device relative to the bus master. The rerun response is similar to retry, but has a lower priority. The shared response indicates that the responding device has a shared (unmodified) copy of the data, but it will not intervene and send a copy to the bus master. Null indicates that the responding device does not have a copy of the data.

FIG. 6 shows in greater detail the data bus portion of memory bus **103**. The data portion contains a set of bidirectional parallel local data buses **601A-601H**, running between processors **101** (or I/O interface units **105**, not shown) and DSW **211**. Because DSW is physically contained on two chips, the high order bits of each bus **601A**, **601C**, **601E**, **601G** are coupled to one of the DSW chips, while the low order bits of each bus **601B**, **601D**, **601F**, **601H** are coupled to the other. FIG. 6 illustrates the local data buses as two separate buses designated **601A**, **601C**, **601E**, **601G**, respectively, and **601B**, **601D**, **601F**, **601H**, respectively, but they are logically a single wide parallel bus, sometimes hereinafter referred to as local data bus **601**. Each local data bus **601** connects a pair of processors **101** (or a single I/O bus interface unit **105**) with a respective port on DSW **211**. DSW **211** contains four bus ports, supporting eight processors **101** (or four I/O bus interface units **105**).

The data bus portion further contains a set of bidirectional point-to-point remote data buses **602A-602D** running between DSW **211** and the memory subsystems **203**. As in the case of the local data buses, the high order bits **602A**, **602C** are coupled to one of the DSW chips, while the low order bits **602B**, **602D** are coupled to the other. Because each remote data bus running between a memory subsystem and DSW is logically a single wide parallel bus, the pair **602A** and **602B** or the pair **602C** and **602D** are sometimes herein referred to as remote data bus **602**.

There is no buffering of data in DSW **212**. As in the case of the ARP **210**, DSW **212** acts as a repeater unit, holding data in

11

registers for two clock cycles when transmitting between a local data bus and a remote data bus.

A separate remote data bus **602** runs from each DSW **211** to each memory subsystem **203**. These buses can carry data independently on the same bus cycle. DSW **212** can direct from any arbitrary local bus to remote bus or vice-versa, provided the buses are free. Thus it is possible for one of the processors in a given node to be transmitting data to (or receiving data from) memory subsystem **0** at the same time that another processor in the same node transmits data to (or receives data from) memory subsystem **1**, provided, however, that these two processors are on different local data buses **601**. This parallelism can be repeated for each node. Since the system supports up to five nodes, it is possible for ten data transfers to be occurring simultaneously.

FIG. 7 shows in greater detail the arbitration lines for supporting arbitration in memory bus **103**. A set of unidirectional local address bus request (ABR) lines **701A-701D** (herein referred to generically as reference number **701**) runs from each processor **101** (or I/O bus interface unit **105**) to a respective port the local ARP unit **210**. Each is a single line carrying a single electrical signal (bit), used by the processor to request the address bus. A corresponding set of unidirectional remote address bus request lines **702A-702B** (herein referred to generically as reference number **702**) runs from ARP **210** to ASW **212**, i.e., for each line **701**, there is one and only one line **702**. ARP **210** acts only as a repeater unit for the local bus request lines **701**, repeating any signal put on a local bus request line **701** by its processor on the corresponding remote address bus request (RDRV_ABR) line **702**. Since there are potentially eight processors in a node, each ARP receives up to eight lines **701**, and drives up to eight lines **702**. The ASW has forty ports for receiving up to forty (eight lines times five nodes) remote address bus request lines **702**.

ASW **212** grants the address bus by signaling on one of the remote address bus grant (RDRV_ABG) links **703A** (herein referred to generically as reference number **703**). Each link **703** is a unidirectional 4-bit bus running from ASW **212** to the local ARP unit **210**. Although multiple address bus requests might come in on the same cycle (requiring a separate request line for each processor), the ASW can only grant the bus to one processor at a time. Therefore, there is no need for forty output ports on the ASW supporting up to forty address bus grant lines **703**. A 4-bit bus to each ARP (total of 20 output lines) is sufficient to specify the identifier of a single processor to which the address bus is granted. Four bits are required because there are nine possible outputs: a bus grant to any one of the eight processors, or no bus grant at all.

The ARP decodes the bus grant signal received on remote bus grant link **703**. If a bus grant to one of its local processors is specified, ARP signals the corresponding processor on unidirectional local address bus grant line **704A-704D** (herein referred to generically as reference number **704**). There is a separate local address bus grant line **704** running from the local ARP to each local processor (total of eight lines). Each ARP unit thus has four input pins for receiving its remote grant line **703**, and eight output pins for driving local grant lines **704**. While FIG. 7 depicts local lines **701** and **704** running to four processors in local node **201**, it will be understood that local lines **701** and **704** connect to all processors, and further that additional remote lines **702**, **703** connect to all nodes, the additional lines being omitted from the figure for clarity of illustration.

Only processors and I/O bus interface units initiate transfers on the memory bus **103**. The memory subsystem itself is merely a passive entity, responding to data transfer requests.

12

Therefore, the memory subsystem does not have any address bus request lines running to ASW **212**.

The data bus is arbitrated separately from the address bus (although not entirely independently, since the address bus must be obtained first before any data transfer can take place). Data bus arbitration is handled by the DSWs. Since there are multiple data bus paths from memory to different processors supporting multiple simultaneous data transfer, global data bus arbitration is not necessary. Arbitration can be handled as the local node level. I.e., the DSW determines whether the local data bus **601** and the remote data bus **602** required to support a requested data transfer are available, and if so, grants the data bus request, without regard to data bus activity to and from other nodes.

A separate unidirectional local data bus request (DBR) line **711A-711D** (herein referred to generically as reference number **711**) runs from each processor **101** (or I/O interface unit **105**) to a respective port on the DSW **211** in its local node. This line is used by the processor to request the data bus (after the address bus has been granted, as explained more fully below). The DSW grants a processor's (or I/O interface unit's) request by signaling on a local data bus grant (DBG) line **712A-712D** (herein referred to generically as reference number **712**), there being a separate unidirectional line **712** for each processor, and a separate port for each such line on DSW **211**. While FIG. 7 depicts local lines **711** and **712** running to four processors in local node **201**, it will be understood that local lines **711** and **712** connect to all processors, the additional lines being omitted from the figure for clarity of illustration.

A separate unidirectional memory data bus request (DBR) line **721A-721B** (herein referred to generically as reference number **721**) runs from each memory subsystem **203** to each DSW **211**, and a separate unidirectional memory data bus grant (DBG) line **722A-722B** (herein referred to generically as reference number **722**) runs from each DSW **211** to each memory subsystem. Lines **721** and **722** support data bus grant and request from the memory subsystem. Although the memory subsystem does not initiate any data transfer operations, it will request control of the bus to complete a data transfer requested by another device. E.g., if a processor requests a read of data in memory, the processor initially obtains the address bus to make the request, but the memory subsystem must obtain the data bus to fulfill the request once the data is available for transfer.

Because the address and data buses are arbitrated separately, there must be some mechanism for matching data to requests. This is accomplished by using a tag. The tag accompanies all commands and all data transmissions. The tag contains the device identifier of the bus master and a sequence number assigned by the bus master. The identifier is not the same as a memory address. Since it only has to identify a unique bus device, a rather small number of bits is required. In the preferred embodiment, six bits uniquely identify a device, three bits identifying the node, two bits identifying the local data bus **601** to which the device is attached, and one bit identifying the device on the local data bus. Thus, the identifier not only uniquely identifies a device, but also identifies its physical location. The sequence number in the preferred embodiment is four bits. The bus master assigns the next available sequence number with each bus transaction it originates. When data is returned to the bus master on a read, the bus master can match it to a request by using the sequence number.

There are additional miscellaneous control lines which are not shown. In particular, there are various steering signal lines for steering data on the data bus. Because the data bus is

granted asynchronously from the address bus (as explained in greater detail below), it is necessary to direct the DSW where to route the data. This mechanism is described in greater detail in commonly assigned copending patent application Ser. No. 09/439,586, to H. Lee Blackmon, et al., entitled “Data Routing Using Status—Response Signals”, herein incorporated by reference.

The operation of the memory bus will now be described with reference to the above described figures and to FIGS. 8-13, representing timing diagrams of system operation. As shown and described in FIG. 2, a global system clock is distributed to all key components and controls the timing of signals transmitted on the memory bus. A memory bus transfer is initiated by either a processor 101 or an I/O bus interface unit 105. The initiator of a bus transfer is referred to as the bus master. The following is a very crude summary of the steps involved in bus transfer (these steps being more fully described herein), it being understood that some steps may not be performed in all cases, some steps may overlap, and some additional steps may be performed in some cases:

- (a) bus master requests and is granted the address bus from the ASW;
- (b) bus master transmits address and command information on the address bus, which is broadcast to all devices;
- (c) devices respond with status, which is collected in the ASW and broadcast;
- (d) devices respond with response, which is collected in the ASW and broadcast;
- (d) data sender (which may or may not be bus master) requests and is granted a data bus; and
- (e) data sender sends data on the data bus.

From a timing standpoint, the simplest bus activity is that which does not involve any use of the data bus, i.e., a command-only bus transfer. An example of a command-only bus transfer would be a request from a processor having a shared copy of some data in its cache to obtain exclusive rights to the data (where cache coherency obeys a M-E-S-I protocol). In this case, it is not always necessary to send the data itself, but it may be necessary to inform other processors in the event they have their own shared copies of the data in their caches. FIG. 8 is a timing diagram of bus activity for a command-only (i.e., no data) bus transfer.

At the top of FIG. 8, the global bus clock cycles are shown. By convention, the receipt of bus grant by the bus master is designated the “0” cycle. A bus transfer is initiated by the bus master pulling ABR line 701 low for one cycle 801. This is shown as cycle “-6”, since it takes at least six cycles for bus grant to be propagated back to the bus master. ABR low is detected by the local ARP 210 (i.e., the ARP in the same node as the bus master). After one intervening cycle, ARP re-drives the bus request signal on RDRV_ABR line 702 at bus cycle “-4” (step 802). RDRV_ABR low is detected by ASW 212.

If the address bus is available, ASW 212 will grant the bus request by driving the appropriate bits on RDRV_ABG link 703 at bus cycle “-2” (step 803). The address bus is available if there are no other requests from the same node in the same cycle or the previous cycle (since transmission of address/command from the local node to the ASW requires two cycles), and if there are no other requests from any other requester (i.e., in a different node) in the same cycle, since only one request can be propagated out of the ASW per cycle. In the event of multiple conflicting requests from different bus masters, the ASW will choose one of the requests for bus grant and defer the other(s) to later bus cycles. Therefore, the timing shown in FIG. 8 should be viewed as minimum timing, as the ASW may wait additional cycles before granting the bus. Any of various conflict resolution schemes can be used

for awarding the bus under these circumstances, such as round-robin, prioritizing based on type of command, random choice, etc.

The local ARP 210 decodes the signals received on RDRV_ABG 703. If a bus grant to one of its local processors (or I/O bus interface units) is indicated, ARP drives the corresponding ABG line 704 low at bus cycle “0” (step 804). This signal is detected by the originating bus master, which now knows that it may transmit on the bus.

By convention, the bus master must transmit its address/command/tag information on bus cycles “2” and “3” from receipt of bus grant; the address, etc. are transmitted to ARP 210 on local address request bus 301 (step 805). As noted, this is a half-width bus requiring two cycles to transmit all the information. ARP 210 re-sends this information to ASW 212 on remote address request bus 302 at bus cycles “4” and “5” (step 806).

ASW 212 loads the address command information received in step 806 into a single wide output register for output in a single bus cycle, and retransmits the information on remote address broadcast bus 303 at bus cycle “7” (step 807). The same address/command/tags are transmitted on all remote address broadcast buses 303 to all ARPs simultaneously. In the same cycle, the same information is transmitted to the memory subsystem on memory address broadcast bus 305. The ARPs retransmit the address/command/tag information to all attached processors and I/O interface units on the local address broadcast buses 304 at bus cycle “9” (step 808).

Each processor, I/O bus interface unit, and memory reports its 2-bit status to ASW on send status link 401 (or link 403, in the case of memory) at bus cycle “11” (step 809). ASW combines the status received from all devices to generate a system status. This system status is then broadcast from ASW to all devices on receive status link 402 (or link 404, in the case of memory) at bus cycle “13” (step 810). Each processor and I/O bus interface unit (but not memory) then generates and transmits its 3-bit response to ASW 212 on the three response lines of send response link 501 at bus cycle “15” (step 811). ASW combines the responses and broadcasts a system response on receive response link 502, also broadcasting the global response to memory on link 504 at bus cycle “17” (step 812). This completes the command-only transmission.

All responses are defined by the architecture and must occur at the predefined bus cycle. In the case of responses up to step 809, the bus cycle is fixed by the architecture. The bus cycle at which steps 810 and 811 occur is determined by values stored in a global system configuration register (step 812 occurs two steps after step 811). This flexibility permits a variable latency depending on the number and configuration of attached devices. However, once established for a particular configuration, the value does not change, and must be observed by all processors.

It will be observed that while the latency for a command-only transmission is a significant number of bus cycles, each resource is used for only one cycle at a time. (The local and remote address request buses 301, 302, are used two cycles, but there are multiple copies of these buses). Therefore, it is possible to initiate a new transmission with every bus cycle (bus masters from the same node can only initiate a new transmission every other cycle). Thus, the maximum possible throughput of the bus is one transmission per clock cycle.

FIG. 9 is a timing diagram of bus activity for a read-from-memory. The memory read transmission begins with exactly the same steps as the command-only transmission shown in FIG. 8 and explained above, i.e., steps 901-912 are performed

at the same bus cycles and using the same resources as steps **801-812** explained above, the only difference being the information that is being transmitted, particularly the command.

A command to read memory necessarily requires the memory interface to go out and get data from physical memory cells, i.e., to decode an address, charge an address line, etc. The latency for all this memory subsystem activity is N bus cycles, which is represented as step **913**. I.e., step **913** is not bus activity, but memory subsystem activity which begins after bus cycle "7", when the memory subsystem receives an address and command from the ASW on memory address broadcast bus **305**. The bus architecture is not dependent on any particular memory technology, and thus the number N may vary. However, if N were less than the 10 cycles required to complete steps **909-912**, it would be necessary for the memory subsystem to wait until these steps were completed.

When the memory subsystem is ready to transmit the requested data, it requests the data bus from DSW **211** by holding the memory data bus request line **721** low at bus cycle "N+4" (step **914**). Since data is only transmitted to the bus master, which is known to the memory subsystem from the tag data, the memory subsystem only signals on the DBR line **721** going to the DSW for the bus master's local node. An additional steering signal (not shown) is required to request a particular local data bus within the bus master's local node. Since data is read from one memory subsystem (but not both), only one of the DBR lines **721** going into the DSW for the bus master's local node is held low in response to the read data request. Other lines and buses may concurrently be used for other data transfers.

If the data bus is available, the DSW **211** responds by holding the memory data bus grant line **722** low at bus cycle "N+6" (step **915**). Only the DBG line **722** going to the requesting memory subsystem is held low. The data bus is available if both the local data bus **601** going between the DSW and the bus master, and the remote data bus **602** going between DSW and the memory subsystem requesting bus grant, will be available at the time of transmission.

The memory subsystem then transmits the data along with the tags to DSW on remote data bus **602**, beginning at bus cycle "N+8" (step **916**). Sixteen bytes of data are transmitted with each bus cycle, the data bus being 16 bytes wide. The tag is repeated with each bus cycle. A single transmission can last a maximum of eight cycles (maximum of 128 bytes of data). To transmit more data, the bus master must make multiple requests for the bus. While transmitting data, the sender holds a data valid (DVal) line low. The sender also holds a data busy (DBusy) line low, releasing it one cycle before end of transmission to let the receiver know that transmission is about to end.

DSW **211** retransmits the data received from the memory subsystem to the bus master on the local data bus **601** servicing the bus master, beginning at bus cycle "N+10" (step **917**). I.e., data is retransmitted on local data bus **601** two bus cycles after transmission on remote data bus **602**. The tag is also repeated each cycle, and DVal and DBusy are held low as before. This completes the memory read transmission.

FIG. **10** is a timing diagram of bus activity for a write-to-memory from the bus master (either a processor **101** or I/O bus interface unit **105**, in which case data is coming from some I/O unit, such as a storage device). The memory write transmission begins with exactly the same steps as the command-only transmission shown in FIG. **8** and explained above, i.e., steps **1001-1012** are performed at the same bus cycles and using the same resources as steps **801-812**

explained above, the only difference being the information being transmitted, particularly the command.

When the bus master receives the bus grant at cycle "0" (step **1004**), it knows that it will be able to begin transmitting the address and command at bus cycle "2", and that the memory subsystem will receive this information at bus cycle "7", these being predefined by the bus architecture. Since there is at least this much latency for data to reach the memory subsystem, it can immediately request the data bus. The bus master requests the data bus by holding local data bus request (DBR) line **711** low at bus cycle "2" (step **1013**). If the data bus is available, the DSW **211** responds by holding the local data bus grant (DBG) line **712** for the bus master low at bus cycle "4" (step **1014**). The data bus is available if both the local data bus **601** going between the bus master and the DSW, and the remote data bus **602** going between the DSW and the memory subsystem where the data will be stored, will be available at the time of transmission.

The bus master then transmits the data along with the tags to DSW **211** on local data bus **601**, beginning at bus cycle "6" (step **1015**). Sixteen bytes of data are transmitted with each bus cycle, the tag being repeated with each bus cycle. As in the case of a read, data transmission is always limited to eight cycles (maximum of 128 bytes of data). While transmitting data, the bus master holds a data valid (DVal) line low. The bus master also holds a data busy (DBusy) line low, releasing it one cycle before end of transmission to let the DSW know that transmission is about to end.

DSW **211** retransmits the data received from the bus master to the memory subsystem on the remote data bus **602** which runs to the memory subsystem where the data will be stored, beginning at bus cycle "8" (step **1016**). Thus, the first 16 bytes of data reach the memory subsystem one bus cycle after the address and command arrive. The tag is also repeated each cycle, and DVal and DBusy are held low as before. This completes the memory write transmission.

The memory bus architecture also supports data transfer between processors **101** and/or I/O bus interface units **105**. There are three flavors of such transfer, each with its own timing. In one case, the two devices are in the same local node **201**, but not on the same local data bus **601**. In a second case, the two devices are in the same local node and are on the same local data bus **601**. In the third case, the two devices are in different local nodes. Such a data transfer might occur, for example, as a result of an attempt to read from memory, where another processor has a more current version of the data to be read in its cache, or might be a read of data from an I/O device.

FIG. **11** is a timing diagram of bus activity for a read-from-device, where the device which is the source of the data is in the same local node as the bus master, but is not on the same local data bus **601** (referred to as a read with local intervention). In the computer system of the preferred embodiment, this type of operation occurs when the bus master attempts to read from memory, but another device (processor) intervenes because it has a more current copy of the data in its cache.

Not surprisingly, the read-from-device begins in exactly the same manner as a read-from-memory, and from the perspective of the bus master, it is a generic read. I.e., steps **1101-1112** are performed at the same bus cycles and using the same resources as steps **901-912** (and **801-812**), explained above. I.e., the bus master sends out only an address, and does not necessarily know where the data is located. After all the units have responded, and status and response have been broadcast by ASW **212**, the devices will know whether the data resides in memory, or some more current copy of the data is in another processor. In particular, the source device will know it is the source device (although other devices will not

necessarily know which is the source device) because the broadcast status/response having highest priority came from it.

After receiving status, the data source device requests the data bus by holding its local data bus request (DBR) line **711** low (step **1113**). This is shown in FIG. **11** at bus cycle “18”, it being understood that this is the earliest such an event may occur, and that the data source device may be busy with other data transfers and unable to request the bus immediately.

If the data bus is available, the DSW **211** responds by holding the corresponding local data bus grant (DBG) line **712** low at bus cycle “20” (step **1114**). The data bus is available if all three of the following will be available at the time of transmission: the local data bus **601** going between the data source device and the DSW, the local data bus **601** going between the DSW and the bus master, and the remote data bus **602** going between the DSW and the memory subsystem in which the data resides. The reason all three must be available is that data in memory will be updated at the same time.

The source device then transmits the data along with the tags to DSW on its local data bus **601**, beginning at bus cycle “22” (step **1115**). Sixteen bytes of data and the tag are transmitted with each bus cycle. While transmitting data, the source device holds a data valid (Dval) and data busy (Dbusy) lines low, releasing Dbusy one cycle before transmission end.

DSW **211** retransmits the data received from the data source device to the bus master on the local data bus **601** servicing the bus master, beginning at bus cycle “24” (step **1116**). I.e., data is retransmitted on local data bus **601** going to the bus master two bus cycles after transmission is received on local data bus **601** from the data source. The tag is also repeated each cycle, and DVal and DBusy are held low as before. On exactly the same bus cycles, the DSW **211** retransmits the same data and tags to the memory subsystem in which the unmodified data resides so that the memory subsystem may update the data. This completes the transmission.

FIG. **12** is a timing diagram of bus activity for a read-from-device, where the device which is the source of the data is in a different local node (referred to as remote intervention). There is no data bus running directly between DSWs in different local nodes. In order to perform this type of a data transfer, data is sent to the memory controller and retransmitted, as described below. Depending on the type of transmission, the memory controller may or may not store the data in memory after it receives the data; however, from the standpoint of bus timing, this activity is irrelevant, because the memory controller does not wait for the data to be stored in the memory subsystem before retransmitting it to the bus master. The read with remote intervention transmission begins with exactly the same steps as the command-only transmission shown in FIG. **8** and explained above, i.e., steps **1201-1212** are performed at the same bus cycles and using the same resources as steps **801-812** explained above, the only difference being the information that is being transmitted, particularly the command.

After status has been broadcast, the devices will know which one is to send the requested data. The data source device therefore requests the data bus by holding its local DBR line **711** low at or after bus cycle “18” (step **1213**). If the data bus is available, the DSW **211** responds by holding the corresponding local data bus grant (DBG) line **712** low at bus cycle “20” (step **1214**). The data bus is available if both the local data bus **601** going between the data source device and the DSW, and the remote data bus **602** going between the DSW and the memory subsystem on which the data resides, will be available at the time of transmission. In some cases, e.g., a transfer from an I/O device to a processor, the data is

not stored in memory, the memory subsystem acting only as a data switch and buffer. In such cases it is possible to send the data to either memory subsystem. As long as the data bus to either subsystem is available, the data will be sent. If both buses are available, a priority scheme will determine which bus to use.

The source device then transmits the data along with the tags to its local DSW on its local data bus **601**, beginning at bus cycle “22” (step **1215**). Sixteen bytes of data and the tag are transmitted with each bus cycle. While transmitting data, the source device holds a data valid (Dval) and data busy (Dbusy) lines low, releasing Dbusy one cycle before transmission end. Up to this point, the transfer is essentially the same as the local intervention data transfer described with respect to FIG. **11**.

The DSW **211** local to the data source retransmits the data received to one of the memory subsystems on remote data bus **602**, beginning at bus cycle “24” (step **1216**). I.e., data is retransmitted on remote data bus **602** to the memory subsystem two bus cycles after transmission is received on local data bus **601** from the data source. The tag is also repeated each cycle, and DVal and DBusy are held low as before.

The data received is buffered in the memory subsystem for transmission to the DSW **211** local to the bus master. Ideally, this retransmission begins after a 3-cycle latency. However, the 3-cycle latency is a minimum latency. The memory subsystem must first obtain the bus going to the bus master, and if this bus is busy the latency could be longer. The memory subsystem requests the data bus to the bus master by lowering its DBR line **721** to the DSW **211** local to the bus master, depicted in FIG. **12** at cycle “24”, which is the earliest it may occur (step **1217**). If the data bus is available, the DSW grants the bus by lowering the DBG line **722** to the memory subsystem (step **1218**). The data bus is available if both the remote data bus **602** running between the memory subsystem and the DSW **211** local to the bus master is available and the local data bus **601** running between the DSW **211** and the bus master is available.

After receiving data bus grant, the memory subsystem transmits the data held in its buffer along with the tags to the DSW **211** local to the bus master on remote data bus **602**, beginning at bus cycle “28” (step **1219**). As in the case of other data transmissions, the memory subsystem holds DVal and DBusy low, releasing Dbusy one cycle before end of transmission.

DSW **211** retransmits the data received from the memory subsystem to the bus master on the local data bus **601** which services the bus master, beginning at bus cycle “30” (step **1220**), also repeating the tag and holding DVal and DBusy low as before. This completes the read with remote intervention.

FIG. **13** is a timing diagram of bus activity for a read-from-device, where the device which is the source of the data is not only in the same local node as the bus master, but is also on the same local data bus **601**. This type of operation is referred to as a local echo, and only occurs between two processors **101**. The device read transmission begins with exactly the same steps as the read with local intervention shown in FIG. **11** and explained above, i.e., steps **1301-1314** are performed at the same bus cycles and using the same resources as steps **1101-1114** explained above.

In the read with local intervention described above with respect to FIG. **11**, the data comes into the DSW on one local data bus **601** and goes out on another, making it possible to use both buses in an overlapping manner, retransmitting data two cycles after initial transmission. This is not possible in the case of the local echo, because only one local data bus **601** is

available for use. Although this is a bidirectional bus serving two processors, the bus architecture is designed so that each processor will ignore any transmission from the other. A separate DVal line runs from DSW 211 to each processor. When the source lowers its DVal line, this is seen only by DSW 211, and not the other processor, and hence the data being transmitted by the source is initially ignored. The DSW must retransmit the data and lower DVal so that the bus master will receive it.

As shown in FIG. 13, the data source begins transmission of the data with tag on local data bus 601 at bus cycle "22", and in the example case of an 8-cycle transmission (eight cycles being the maximum permitted in the architecture), completes transmission on bus cycle "29" (step 1315). In this transmission, the data source device lowers DVal and DBusy going to the DSW.

The DSW must wait until all the data is transmitted by the data source before it can use the same local data bus 601. Beginning with bus cycle "31", it retransmits the data received with the tag to the bus master on local data bus 601 (step 1316). In this transmission, the DSW lowers DVal and DBusy going to the bus master.

Since the updated data from a processor's cache should be simultaneously updated in memory, DSW 211 concurrently transfers the data to the appropriate memory subsystem on remote data bus 602 (step 1317). Note that this transfer begins at bus cycle "24". I.e., it is not necessary to wait until all the data from the source device is received, because it is being retransmitted to memory on a physically separate bus connection.

FIG. 14 is a timing diagram of bus activity for a write-to-device. This is used, e.g., to write from a processor to an I/O interface unit, and always occurs across nodes. Like the remote intervention transaction, a write-to-device is accomplished by sending the data first to a memory subsystem controller, which then re-transmits it to the destination device (without storing the data in the memory subsystem). The write-to-device therefore begins with exactly the same steps as the write-to-memory shown in FIG. 10 and explained above, i.e., steps 1401-1416 are performed at the same bus cycles and using the same resources as steps 1001-1016 explained above.

After status/response have been broadcast, the memory subsystem will know where to send the requested data. The memory subsystem therefore requests the data bus going to the local node of the destination device by holding the appropriate DBR line 721 low at or after bus cycle "18" (step 1417). If the data bus is available, the DSW 211 responds by holding the corresponding remote data bus grant (DBG) line 722 low at bus cycle "20" (step 1418). The data bus is available if both the remote data bus 602 going between the memory subsystem and the DSW servicing the destination device, and the local data bus 601 going between the DSW and the destination device, will be available at the time of transmission.

The memory subsystem then re-transmits the data along with the tags to the DSW on remote data bus 602, beginning at bus cycle "22" (step 1419). While transmitting data, the memory subsystem holds a data valid (Dval) and data busy (Dbusy) lines low, releasing Dbusy one cycle before transmission end. The DSW 211 local to the destination device retransmits the data received to the destination device on local data bus 601, beginning at bus cycle "24" (step 1420). The tag is also repeated each cycle, and DVal and DBusy are held low as before. This completes the write-to-device transaction.

In the design of processor chips, it is well known that the number of available I/O pins is a severe constraint. The use of a narrower bus for transmitting commands/addresses/tags

reduces the number of I/O pins required of a processor chip. FIG. 15 illustrates a processor chip and its I/O pin requirements at a high level. It will be understood that FIG. 15 is a greatly simplified diagram, and that a typical processor will have many components, such as on-board caches, registers, ALUs, instruction decode logic, instruction sequencer, etc., which are not shown. In the preferred embodiment, the chip has approximately 1000 available pins. The processor chip has an on-board L1 cache, but the L2 cache is on a separate chip. Approximately half of the available pins are used by the L2 cache interface 1505. Many remaining pins are required for power, clock, testing, configuration inputs, etc. This leaves a limited number of pins for the processor/memory bus interface 1506. The data bus portion includes data bus request pin 1510, data bus grant pin 1511, the bidirectional data bus itself 1512, and miscellaneous control/steering pins not shown. The address/command bus portion includes command bus request pin 1501 (for driving a request line 701), command bus grant pin 1502 (for receiving a grant line 704), command output pins 1503 (for driving link 301) and command input pins 1504 (for receiving link 304). It also includes miscellaneous status, response and other pins collectively designated 1520. According to the preferred embodiment of the present invention, the number of command output pins 1503 required is approximately half that of the number of command input pins 1504. The number of pins shown in FIG. 15 is intended as a conceptual representation only; the actual number is much greater and would be difficult to illustrate in a single drawing.

Thus bus architecture described herein facilitates connection to a relatively large number of processors and I/O interface units. In the preferred embodiment, there is an architectural limit of approximately 37 devices, this limit being imposed largely by the number of available I/O pins in the DSW, ASW and ARP chips. However, it will readily be appreciated by those skilled in the art that the architectural concepts explained herein could easily be employed to support larger number of devices, e.g., by using additional switching chips.

In the preferred embodiment, a particular timing sequence is presented. It will readily be understood by those skilled in the art that the timing sequences presented herein are exemplary in nature, and that the architectural concepts explained herein could use different timing sequences, provided the timing sequence protocol is observed by all bus devices. It will further be understood that in some cases there may be a variable delay between the occurrence of certain events which require separate arbitration, and that the timing diagrams presented herein show only one set of examples of such delays.

In the preferred embodiment, certain status and response signals are transmitted, these being divided in two different bus cycles. It would alternatively be possible to combine these responses in a single bus cycle, to transmit other information as part of status/response, to allocated additional bus cycles for status response, etc.

In the preferred embodiment, a "node" is physically packaged as a single electronic circuit card and has multiple chips mounted thereon. However, a node could have different physical embodiments, e.g., as multiple circuit cards in a mother-daughter arrangement, or multiple cards in a special packaging arrangement, or even possibly as a single chip. The significance of the node is that communication within a node is easier than between nodes. A single circuit card was chosen as the node boundary because communication across a card boundary requires connectors, drivers and other hardware to support it, making it desirable to minimize the number of lines crossing the card boundary

In the preferred embodiment, certain functions are combined on a single chip or divided among pairs of chips. However, the exact number of chips used to perform functions may vary, and as described herein, devices are grouped by logical function rather than packaging. For example, it may be possible to combine the two DSW chips on a single chip, or even to combining the ARP and DSW chips on a single chip. It may alternatively be possible to implement the ARP as multiple chips. The logic functions required of the ARP, DSW and ASW are far less complex than a single processor chip, but multiple chips are used chiefly to obtain the requisite number of I/O pins.

In the preferred embodiment, the bus links are configured hierarchically, so that a local repeater services multiple local links. However, it would alternatively be possible for multiple input links to go directly from devices to the central repeater, and for the central repeater's output to go directly to all devices, without intermediate local repeater units. Many other variations in the topology or types of links are also possible.

In the preferred embodiment, the input links are half the width of the broadcast bus, requiring two bus cycles to transmit a complete command. However, the input links could be $\frac{1}{3}$, or $\frac{1}{4}$ or some other fraction of the broadcast bus. The purpose of the multiple input links is to utilize the broadcast bus to the fullest extent possible. As the number of devices in the network grows larger, and the number of input links grows correspondingly, it may be predicted that narrower input links are still sufficient to fill the broadcast bus.

In the preferred embodiment, the local request links running from devices to ARP, and the remote request bus links running from ARP to the central repeater, are the same width. However, it would be possible to employ differing widths. For example, the local request links could be $\frac{1}{4}$ bus width while the remote request links are $\frac{1}{2}$ bus width. Alternatively, the remote request link(s) might be full width, while only the local request links are less than full width.

In the preferred embodiment, only processors, memory, and I/O interface devices are attached to the bus, but it would alternatively be possible to attach other types of devices.

Although a specific embodiment of the invention has been disclosed along with certain alternatives, it will be recognized by those skilled in the art that additional variations in form and detail may be made within the scope of the following claims:

What is claimed is:

1. A computer system, comprising:
 - a plurality of devices for transmitting bus commands;
 - a central repeater for broadcasting commands;
 - a plurality of first uni-directional command bus links for transmitting commands from originating devices to said central repeater;
 - a uni-directional command bus broadcast portion for broadcasting commands from said central repeater to all devices attached to said command bus;
 - wherein each of said plurality of first uni-directional command bus links is less wide than said uni-directional command bus broadcast portion, whereby a plurality of bus cycles is required to transmit a command on one of said links, the same command being broadcast from said central repeater in a single bus cycle.
2. The computer system of claim 1, wherein said system comprises a plurality of processors, at least some of said devices for transmitting bus commands being processors.
3. The computer system of claim 1, further comprising:
 - a global command bus arbitrator, said arbitrator granting devices the right to transmit respective commands at

respective bus cycles, wherein each command is broadcast by said central repeater a pre-defined number of cycles N after said arbitrator granted the right to transmit the command.

4. The computer system claim 1, further comprising:
 - a plurality of local request repeaters, each of said first unidirectional command bus links running from a device to an associated local request repeater; and
 - at least one second uni-directional command bus link, each of said at least one second links transmitting commands from a local request repeater to said central repeater.
5. The computer system claim 4, wherein said uni-directional command bus broadcast portion comprises:
 - a plurality of local broadcast repeaters;
 - at least one third uni-directional command bus link transmitting commands from said central repeater to said plurality of local broadcast repeaters; and
 - a plurality of fourth uni-directional command bus links, each of said fourth uni-directional command bus links transmitting commands from a respective local broadcast repeater to at least one device.
6. The computer system of claim 5, further comprising:
 - a global command bus arbitrator, said arbitrator granting devices the right to transmit respective commands at respective bus cycles;
 - wherein each command is transmitted by a device on a first uni-directional link a pre-defined number of cycles N after said arbitrator granted the right to transmit the command, is transmitted by a local request repeater on a second uni-directional link a pre-defined number of cycles M after said arbitrator granted the right to transmit the command, is transmitted by said central repeater on said at least one third link a pre-defined number of cycles L after said arbitrator granted the right to transmit the command, and is transmitted by each of said plurality of local broadcast repeaters on each respective fourth link a pre-defined number of cycles K after said arbitrator granted the right to transmit the command, wherein $N < M < L < K$.
7. A method for communicating between devices attached to a communication bus in a computer system, said communication bus including a command bus portion, said method comprising the steps of:
 - requesting control of said command bus portion by a first device attached to said communication bus during a first bus cycle;
 - receiving a grant of control of said command portion by said first device during a second bus cycle;
 - transmitting command information for a bus command on a first link of said command bus portion from said first device to a repeater unit during a plurality of consecutive bus cycles beginning with a third bus cycle and ending on a fourth bus cycle, said third and fourth bus cycles occurring a respective pre-defined number of cycles after said second bus cycle; and
 - re-transmitting said command information on a second link of said command bus portion from a repeater unit to second device attached to said communication bus during a fifth bus cycle, said fifth bus cycle occurring a pre-defined number of cycles after said second bus cycle, wherein command information transmitted on said first link during multiple cycles is transmitted on said second link in a single cycle.
8. The method of claim 7, further comprising the steps of:
 - requesting control of a data portion of said communications bus by said second device during a sixth bus cycle, said sixth bus cycle occurring after said fifth bus cycle,

23

said requesting control of said data portion step being responsive to said bus command;
 receiving a grant of control of said data portion by said second device during a seventh bus cycle;
 transmitting data on said data portion from said second device during an eighth bus cycle, said eighth bus cycle occurring a pre-defined number of cycles after said seventh bus cycle.

9. The method of claim 8, wherein said command information includes a tag uniquely identifying said bus command, and wherein said tag is transmitted simultaneously with said data on said data portion.

10. A processor for use in a multi-processor computer system, said computer system having a communications bus for communicating among processors and memory, said communications bus having a command bus portion for transmitting commands from an originating processor to other devices attached to the communications bus, said processor comprising:

a command bus request port for requesting the right to transmit a command on said command bus portion from an arbitrator;
 a command bus grant port for receiving bus grant from said arbitrator;
 a command output port having a plurality N of output pins for transmitting bus commands;
 a command receive port having a plurality M of input pins for receiving bus commands, wherein $M > N$, the number of input pins M being sufficient to receive a bus command in one bus cycle; and

interface logic for transmitting bus commands on said command output port responsive to receiving bus grant from said arbitrator, wherein a bus command is transmitted from said plurality of output pins during a plurality of consecutive bus cycles beginning with a first cycle occurring a first pre-defined number of bus cycles after said processor receives bus grant and ending with a second bus cycle occurring a second pre-defined number of bus cycles after said processor receives bus grant.

11. A memory system comprising:

a memory controller having an interface that includes a plurality of memory subsystem ports;

a first memory subsystem including:

a buffer device having a first port and a second port, and a plurality of memory devices coupled to the buffer device via the second port, wherein data is transferred between at least one memory device of the plurality of memory devices and the memory controller via the buffer device; and

a plurality of point-to-point links, each point-to-point link of the plurality of point-to-point links having a connection to a respective memory subsystem port of the plurality of memory subsystem ports, the plurality of point-to-point links including a first point-to-point link to connect the first port to a first memory subsystem port of the plurality of memory subsystem ports.

12. The memory system of claim 11, further including:

a plurality of connectors, wherein each connector of the plurality of connectors is connected to a respective point-to-point link of the plurality of point-to-point links; and

a plurality of memory subsystems, and wherein each memory subsystem of the plurality of memory subsystems includes:

a buffer device having a first port and a second port, wherein the first port is coupled to a respective connector of the plurality of connectors; and

24

a plurality of memory devices coupled to the buffer device via the second port.

13. The memory system of claim 12, further including a plurality of substrates wherein each memory subsystem of the plurality of memory subsystems is disposed on a respective substrate of the plurality of substrates.

14. The memory system of claim 11, wherein the first memory subsystem further includes a plurality of channels and a plurality of memory device select lines connected between the plurality of memory devices and the second port.

15. The memory system of claim 14, wherein each channel of the plurality of channels includes a plurality of high speed terminated signal lines.

16. The memory system of claim 11, further including a second memory subsystem including:

a buffer device having a first port and a second port, wherein the first port is connected to a second point-to-point link of the plurality of point-to-point links; and a plurality of memory devices coupled to the buffer device via the second port.

17. The memory system of claim 11, further including a module substrate having a connector interface, wherein the first memory subsystem is disposed on the module substrate, and the buffer device is electrically connected to the connector interface, wherein the buffer device further comprises a memory address interface unit and transceives data, control and address signals between the plurality of memory devices and the connector interface.

18. The memory system of claim 11, further including a first termination coupled to the first point-to-point link to terminate a first end of the first point-to-point link, wherein the first point-to-point link is a high speed link.

19. The memory system of claim 18, further including a second termination coupled to the first point-to-point link to terminate a second end of the first point-to-point link.

20. The memory device of claim 11, wherein the buffer device comprises a write buffer, coupled to the first port, to hold data to be provided to at least one memory device of the plurality of memory devices.

21. The system according to claim 11, wherein the buffer device comprises a memory data interface unit for transceiving data between at least one point-to-point link and at least one memory device.

22. The system according to claim 11, wherein the memory controller comprises a data switch for transceiving data to and from the first memory subsystem.

23. The system according to claim 13, wherein each substrate comprises a card or assembly of cards.

24. The system according to claim 11, wherein the first point-to-point link comprises a bidirectional point-to-point data bus.

25. A memory system comprising:

a controller device;

a first buffer device having a first interface and a second interface;

a second buffer device having a first interface and a second interface;

a first point-to-point link having a first connection to the controller device and a second connection to the first interface of the first buffer device;

a first plurality of memory devices connected to the second interface of the first buffer device;

a second point-to-point link having a first connection to the controller device and a second connection to the first interface of the second buffer device; and

a second plurality of memory devices connected to the second interface of the second buffer device.

25

26. The memory system of claim 25, wherein the first buffer device and first plurality of memory devices are disposed on a first substrate, and the second buffer device and second plurality of memory devices are disposed on a second substrate.

27. The memory system of claim 26, further including:
a first plurality of high speed signal lines to connect the first plurality of memory devices to the second interface of the first buffer device;

a second plurality of high speed signal lines to connect the second plurality of memory devices to the second interface of the second buffer device;

a first plurality of termination elements connected to the first plurality of high speed signal lines; and

a second plurality of termination elements connected to the second plurality of high speed signal lines.

28. The memory system of claim 25, further including a third point-to-point link having a connection to the controller and a fourth point-to-point link having a connection to the controller.

29. The memory system of claim 25, further including:

a first channel to connect the first plurality of memory devices to the second interface of the first buffer device;

a second channel to connect the second plurality of memory devices to the second interface of the second buffer device;

a third channel connected to the second interface of the first buffer device;

a third plurality of memory devices electrically coupled to the third channel;

a fourth channel connected to the second interface of the second buffer device; and

a fourth plurality of memory devices electrically coupled to the fourth channel.

30. The memory system of claim 25, further including at least one termination element electrically connected to the first point-to-point link, wherein the first point-to-point link is a high speed link.

31. The memory system of claim 25, further including a module substrate having a connector interface, wherein the first buffer device is disposed on the module substrate, and the first buffer device is electrically connected to the connector interface, and wherein the first buffer device further comprises a memory address interface unit and transceives data, control and address information between the first plurality of memory devices and the connector interface.

32. The memory device of claim 25, wherein the first buffer device further includes a write buffer, coupled to the first interface of the first buffer device, to hold data to be provided to at least one memory device of the first plurality of memory devices.

33. A memory system comprising:

a controller device;

a first and second plurality of buffer devices, each buffer device of the first and second plurality of buffer devices having an interface connected to a respective plurality of memory devices;

a first and second repeater device;

a first point-to-point link having a first connection to the controller device and a second connection to the first repeater device;

a second point-to-point link having a first connection to the controller device and a second connection to the second repeater device;

a first plurality of repeater links, each repeater link having first connection to a respective buffer device of the first plurality of buffer devices, and a second connection to the first repeater device; and

26

a second plurality of repeater links, each repeater link having first connection to a respective buffer device of the second plurality of buffer devices and a second connection to the second repeater device.

34. The memory system of claim 33, wherein a first buffer device of the first plurality of buffer devices and a first buffer device of the second plurality of buffer devices, and corresponding pluralities of memory devices, are disposed on one of a plurality of respective module substrates.

35. The memory system of claim 33, further including a third point-to-point link having an end connected to the controller device and a fourth point-to-point link having an end connected to the controller device.

36. The memory device of claim 33, wherein each buffer device of the first plurality of buffer devices comprises a write buffer to hold data to be provided to at least one memory device of the respective plurality of memory devices.

37. The system according to claim 33, wherein each buffer device of the second plurality of buffer devices comprises a memory address interface unit for transceiving address information to and from at least one memory device.

38. The system according to claim 33, wherein the second repeater device comprises an address repeater unit for transceiving address information to and from the controller.

39. The system according to claim 38, wherein the second repeater device further comprises an address switch for transceiving the address information to and from the address repeater unit.

40. The system according to claim 33, wherein the second plurality of repeater links comprise an address bus for transmitting address information from the second repeater unit to the second plurality of buffer devices, the address information being associated with data transceived between the first repeater device and the first plurality of buffer devices.

41. A memory system comprising:

a controller device having an interface;

a first connector, second connector, and third connector;

a first point-to-point link having a first connection to the interface and a second connection to the first connector;

a second point-to-point link having a first connection to the interface and a second connection to the second connector;

a third point-to-point link having a first connection to the interface and a second connection to the third connector; and

a first memory subsystem including:

a buffer device connected to the first connector; and

a plurality of memory devices connected to the buffer device, wherein at least one memory device of the plurality of memory devices transfers data to the controller device via the buffer device.

42. The memory system of claim 41, wherein the second and third connectors support coupling to a plurality of memory subsystems.

43. The memory system of claim 41, further including a module substrate having a connector interface, wherein the first memory subsystem is disposed on the module substrate, and the buffer device is electrically connected to the connector interface, and wherein the buffer device further comprises a memory address interface unit and transceives data, control and address signals between the plurality of memory devices and the connector interface.

44. The memory system of claim 41, further including a first termination to terminate the second connection of the first point-to-point link, wherein the first point-to-point link is a high speed link.

27

45. The memory system of claim 44, further including a second termination to terminate the first connection of the first point-to-point link.

46. The memory device of claim 41, wherein the buffer device comprises a write buffer to hold data to be provided to at least one memory device of the plurality of memory devices.

47. A memory system comprising:

a controller device;

a plurality of buffer devices, each buffer device of the plurality of buffer devices having an interface connected to a respective plurality of memory devices;

a repeater device;

a point-to-point link having a first connection to the controller device and a second connection to the repeater device;

a plurality of repeater links, each repeater link having first connection to a respective buffer device of the plurality of buffer devices, and a second connection to the repeater device.

48. A memory system comprising:

a memory controller having an interface that includes a plurality of memory subsystem ports;

a first memory subsystem including:

a memory data interface unit having a first port and a second port, and

a plurality of memory devices coupled to the memory data interface unit via the second port, wherein data is transferred between at least one memory device of the plurality of memory devices and the memory controller via the memory data interface unit; and

a plurality of point-to-point links, each point-to-point link of the plurality of point-to-point links having a connection to a respective memory subsystem port of the plurality of memory subsystem ports, the plurality of point-to-point links including a first point-to-point link to connect the first port to a first memory subsystem port of the plurality of memory subsystem ports.

49. A memory system comprising:

a controller device;

a first memory data interface unit having a first interface and a second interface;

a second memory data interface unit having a first interface and a second interface;

a first point-to-point link having a first connection to the controller device and a second connection to the first interface of the first memory data interface unit;

a first plurality of memory devices connected to the second interface of the first memory data interface unit;

a second point-to-point link having a first connection to the controller device and a second connection to the first interface of the second memory data interface unit; and

a second plurality of memory devices connected to the second interface of the second memory data interface unit.

50. A memory system comprising:

a controller device;

a plurality of memory data interface units, each memory data interface unit of the plurality of memory data interface units having an interface connected to a respective plurality of memory devices;

a repeater device;

a point-to-point link having a first connection to the controller device and a second connection to the repeater device;

a plurality of repeater links, each repeater link having first connection to a respective memory data interface unit of

28

the plurality of memory data interface units, and a second connection to the repeater device.

51. A memory system comprising:

a controller device having an interface;

a first connector, second connector, and third connector;

a first point-to-point link having a first connection to the interface and a second connection to the first connector;

a second point-to-point link having a first connection to the interface and a second connection to the second connector;

a third point-to-point link having a first connection to the interface and a second connection to the third connector; and

a first memory subsystem including:

a memory data interface unit connected to the first connector; and

a plurality of memory devices connected to the memory data interface unit, wherein at least one memory device of the plurality of memory devices transfers data to the controller device via the memory data interface unit.

52. A memory system comprising:

a data switch having an interface that includes a plurality of memory subsystem ports;

a first memory subsystem including:

a memory data interface unit having a first port and a second port, and

a plurality of memory devices coupled to the memory data interface unit via the second port, wherein data is transferred between at least one memory device of the plurality of memory devices and the data switch via the memory data interface unit; and

a plurality of point-to-point links, each point-to-point link of the plurality of point-to-point links having a connection to a respective memory subsystem port of the plurality of memory subsystem ports, the plurality of point-to-point links including a first point-to-point link to connect the first port to a first memory subsystem port of the plurality of memory subsystem ports.

53. A memory system comprising:

a data switch;

a first memory data interface unit having a first interface and a second interface;

a second memory data interface unit having a first interface and a second interface;

a first point-to-point link having a first connection to the data switch and a second connection to the first interface of the first memory data interface unit;

a first plurality of memory devices connected to the second interface of the first memory data interface unit;

a second point-to-point link having a first connection to the data switch and a second connection to the first interface of the second memory data interface unit; and

a second plurality of memory devices connected to the second interface of the second memory data interface unit.

54. A memory system comprising:

a controller device;

a plurality of memory data interface units, each memory data interface unit of the plurality of memory data interface units having an interface connected to a respective plurality of memory devices;

a data switch;

a point-to-point link having a first connection to the controller device and a second connection to the data switch;

a plurality of repeater links, each repeater link having first connection to a respective memory data interface unit of

29

the plurality of memory data interface units, and a second connection to the data switch.

55. *A memory system comprising:*

a data switch having an interface;

a first connector, second connector, and third connector; 5

a first point-to-point link having a first connection to the interface and a second connection to the first connector;

a second point-to-point link having a first connection to the interface and a second connection to the second connector; 10

a third point-to-point link having a first connection to the interface and a second connection to the third connector; and

a first memory subsystem including:

a memory data interface unit connected to the first connector; and 15

a plurality of memory devices connected to the memory data interface unit, wherein at least one memory device of the plurality of memory devices transfers data to the data switch via the memory data interface unit. 20

56. *A memory system comprising:*

a data switch having an interface that includes a plurality of memory subsystem ports;

a first memory subsystem including: 25

a memory data interface unit having a first port and a second port, and

a plurality of memory devices coupled to the memory data interface unit via the second port, wherein data is transferred between at least one memory device of the plurality of memory devices and the data switch via the memory data interface unit; and 30

a plurality of bidirectional point-to-point data buses, each bidirectional point-to-point data bus of the plurality of bidirectional point-to-point data buses having a connection to a respective memory subsystem port of the plurality of memory subsystem ports, the plurality of bidirectional point-to-point data buses including a first bidirectional point-to-point data bus to connect the first port to a first memory subsystem port of the plurality of memory subsystem ports. 35 40

57. *A memory system comprising:*

a data switch;

a first memory data interface unit having a first interface and a second interface; 45

a second memory data interface unit having a first interface and a second interface;

30

a first bidirectional point-to-point data bus having a first connection to the data switch and a second connection to the first interface of the first memory data interface unit; a first plurality of memory devices connected to the second interface of the first memory data interface unit;

a second bidirectional point-to-point data bus having a first connection to the data switch and a second connection to the first interface of the second memory data interface unit; and

a second plurality of memory devices connected to the second interface of the second memory data interface unit.

58. *A memory system comprising:*

a controller device;

a plurality of memory data interface units, each memory data interface unit of the plurality of memory data interface units having an interface connected to a respective plurality of memory devices;

a data switch;

a point-to-point link having a first connection to the controller device and a second connection to the data switch;

a plurality of bidirectional point-to-point data buses, each bidirectional point-to-point data bus having first connection to a respective memory data interface unit of the plurality of memory data interface units, and a second connection to the data switch.

59. *A memory system comprising:*

a data switch having an interface;

a first connector, second connector, and third connector;

a first bidirectional point-to-point data bus having a first connection to the interface and a second connection to the first connector;

a second bidirectional point-to-point data bus having a first connection to the interface and a second connection to the second connector;

a unidirectional memory data bus line having a first connection to the interface and a second connection to the third connector; and

a first memory subsystem including:

a memory data interface unit connected to the first connector; and

a plurality of memory devices connected to the memory data interface unit, wherein at least one memory device of the plurality of memory devices transfers data to the data switch via the memory data interface unit.

* * * * *