

US00RE44140E

(19) **United States**
(12) **Reissued Patent**
Beasom

(10) **Patent Number:** **US RE44,140 E**
(45) **Date of Reissued Patent:** **Apr. 9, 2013**

(54) **BIPOLAR METHOD AND STRUCTURE
HAVING IMPROVED BVCEO/RCS
TRADE-OFF MADE WITH DEPLETABLE
COLLECTOR COLUMNS**

(56) **References Cited**

U.S. PATENT DOCUMENTS

4,532,003 A 7/1985 Beasom
4,729,008 A 3/1988 Beasom
(Continued)

FOREIGN PATENT DOCUMENTS

JP 58040857 3/1983
JP 2000208527 7/2000
(Continued)

OTHER PUBLICATIONS

Millman, "Microelectronics: Digital and Analog Circuits and Systems", "Chapter 3", 1979, pp. 57-65, Publisher: McGraw-Hill, Inc.
Japan Patent Office, "Notification of Reasons for Refusal", Mailed Jul. 10, 2012, Published in: JP.
European Patent Office, "Office Action", "from Foreign Counterpart of U.S. Appl. No. 11/217,304", Oct. 18, 2012, pp. 1-5, Published in: EP.
Jacob Millman, Microelectronics, 1997, McGraw-Hill Book Company, Chapter 3, pp. 57-65.

Primary Examiner — Thanh V Pham
(74) *Attorney, Agent, or Firm* — Fogg & Powers LLC

(75) Inventor: **James D. Beasom**, Melbourne Village, FL (US)

(73) Assignee: **Intersil Americas Inc.**, Milpitas, CA (US)

(21) Appl. No.: **13/295,764**

(22) Filed: **Nov. 14, 2011**

Related U.S. Patent Documents

Reissue of:

(64) Patent No.: **7,473,983**
Issued: **Jan. 6, 2009**
Appl. No.: **11/835,885**
Filed: **Aug. 8, 2007**

U.S. Applications:

(60) Continuation of application No. 12/985,856, filed on Jan. 6, 2011, now Pat. No. Re. 43,042, which is a division of application No. 11/217,304, filed on Sep. 2, 2005, now Pat. No. 7,285,469.

(51) **Int. Cl.**
H01L 21/8222 (2006.01)
H01L 29/40 (2006.01)

(52) **U.S. Cl.** **438/309; 438/311; 438/322; 438/340; 257/565; 257/47; 257/197; 257/575; 257/E21.381; 257/E27.053; 257/E27.074**

(58) **Field of Classification Search** **438/309, 438/311, 322, 340, FOR. 165, FOR. 166; 257/21.381, 47, 197, 565, 575, E21.381, 257/E27.053, E27.074**

See application file for complete search history.

(57) **ABSTRACT**

In accordance with the invention, there are various methods of making an integrated circuit comprising a bipolar transistor. According to an embodiment of the invention, the bipolar transistor can comprise a substrate, a collector comprising a plurality of alternating doped regions, wherein the plurality of alternating doped regions alternate in a lateral direction from a net first conductivity to a net second conductivity, and a collector contact in electrical contact with the collector. The bipolar transistor can also comprise a heavily doped buried layer below the collector, a base in electrical contact with a base contact, wherein the base is doped to a net second conductivity type and wherein the base spans a portion of the plurality of alternating doped regions, and an emitter disposed within the base, the emitter doped to a net first conductivity, wherein a portion of the alternating doped region under the emitter is doped to a concentration of less than about $3 \times 10^{12} \text{ cm}^{-2}$.

24 Claims, 16 Drawing Sheets

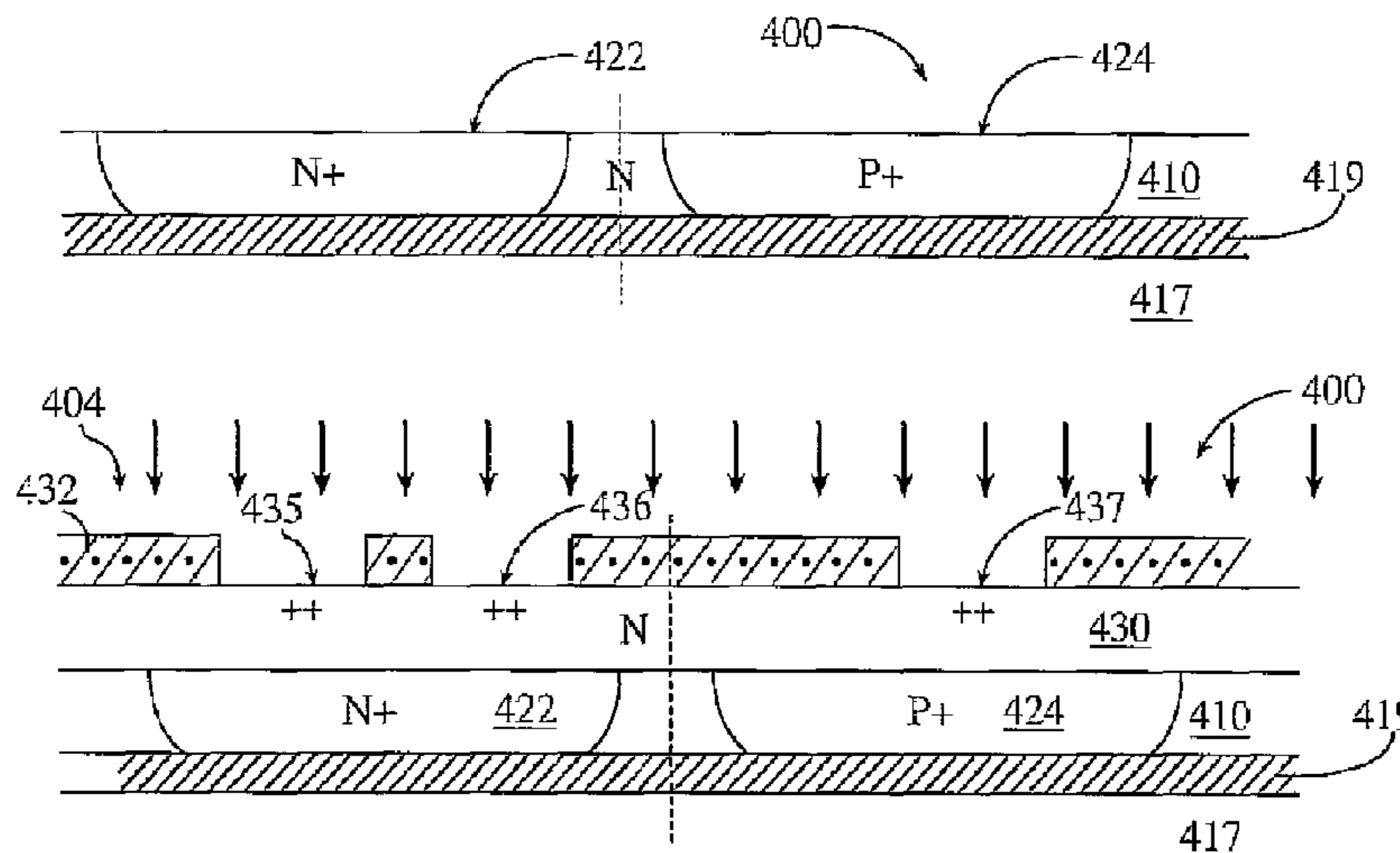

US RE44,140 E

Page 2

U.S. PATENT DOCUMENTS

5,344,785	A	9/1994	Jerome et al.
5,428,233	A	6/1995	Walczyk
5,633,180	A	5/1997	Bajor
2002/0000640	A1	1/2002	Zhu
2002/0113275	A1	8/2002	Stecher et al.
2002/0179933	A1	12/2002	El-Sharawy et al.
2003/0008483	A1	1/2003	Sato et al.
2004/0212032	A1	10/2004	Onishi et al.
2004/0238882	A1	12/2004	Suzuki et al.

2005/0035424	A1	2/2005	Beasom
2005/0074942	A1	4/2005	An et al.
2005/0184336	A1	8/2005	Takahashi et al.

FOREIGN PATENT DOCUMENTS

WO	0184631	11/2001
WO	WO 0184631	11/2001
WO	2005020275	3/2005
WO	WO 2005020275	3/2005

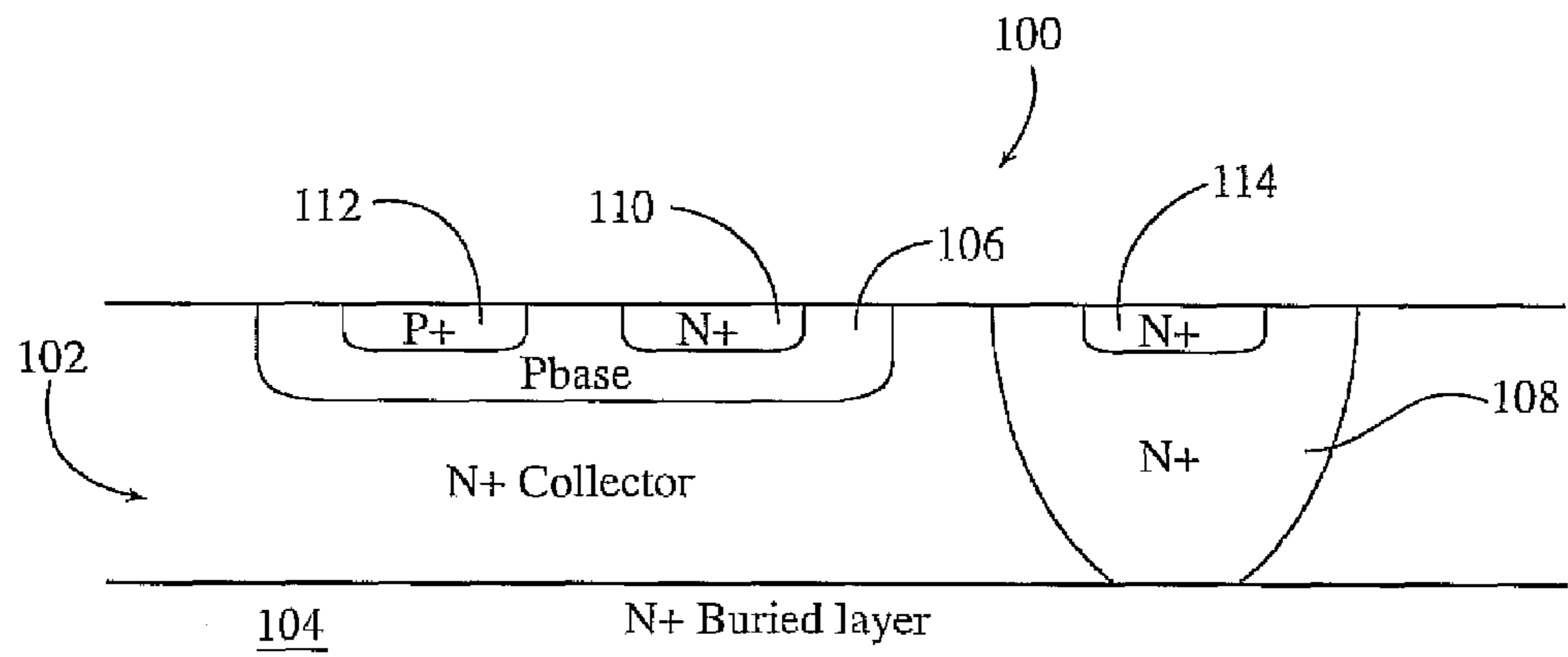

Fig 1

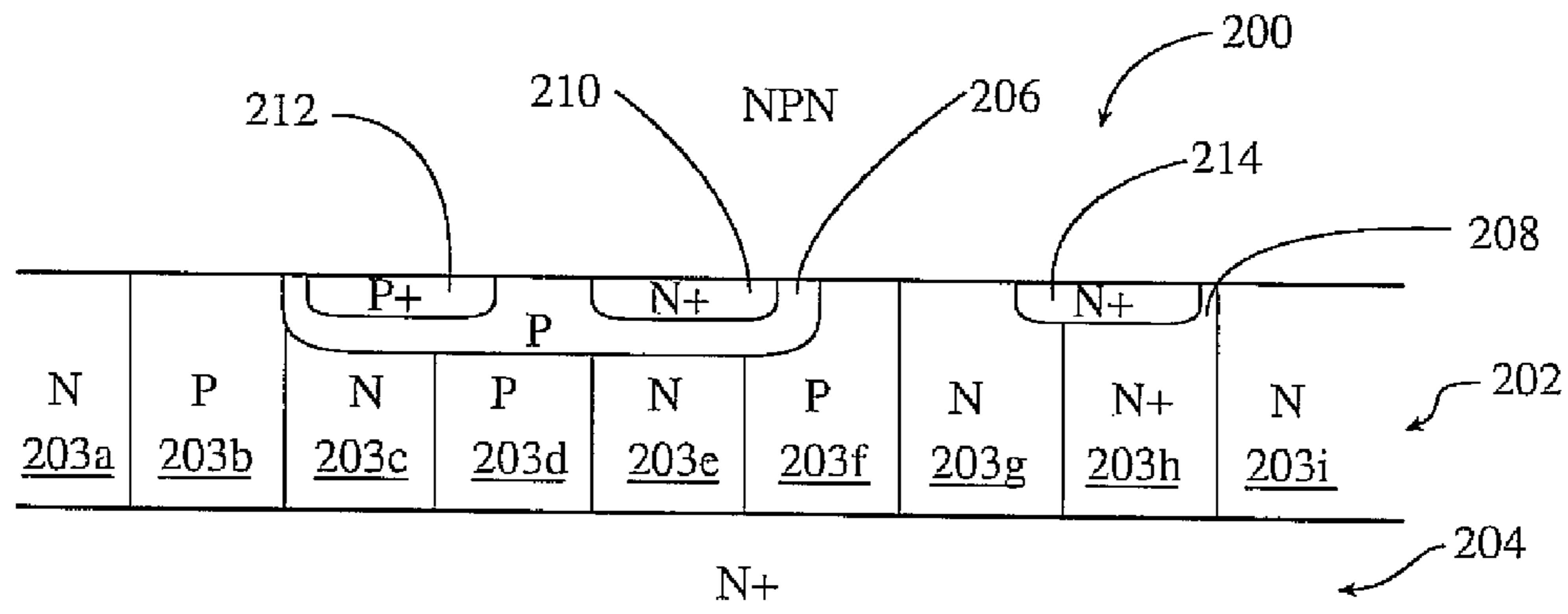

Fig 2A

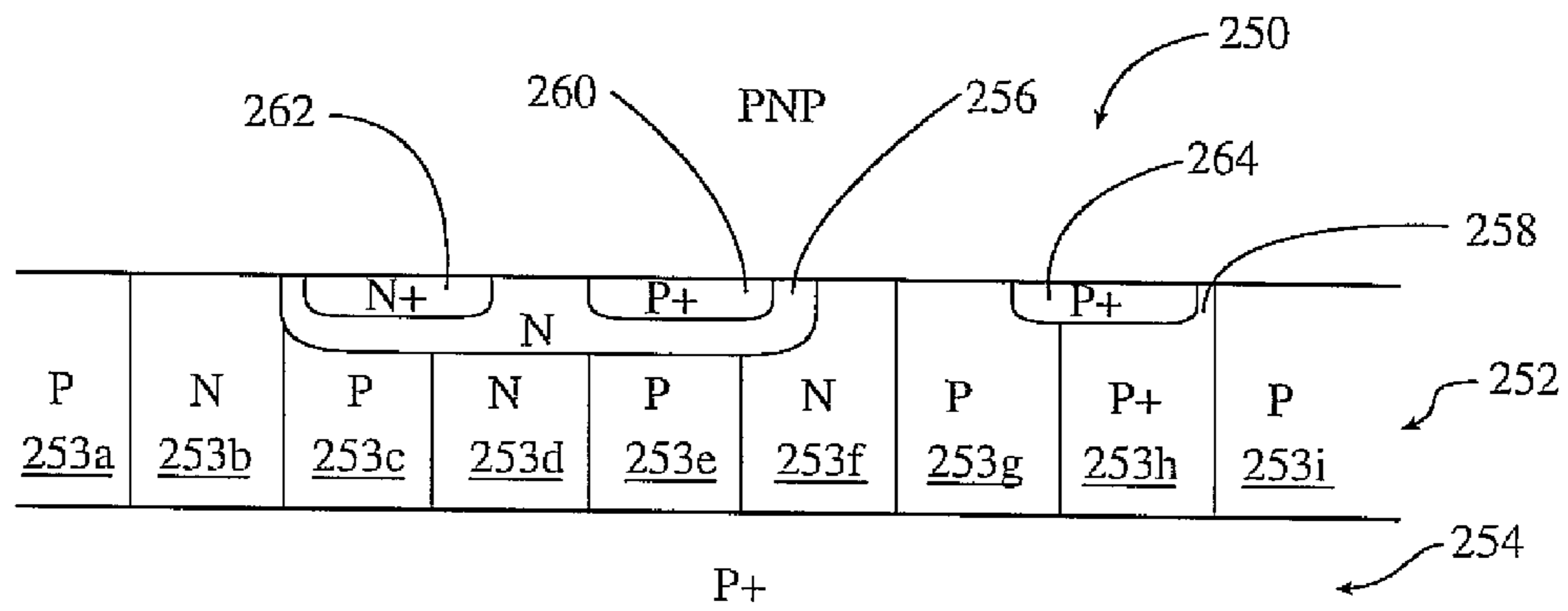

Fig 2B

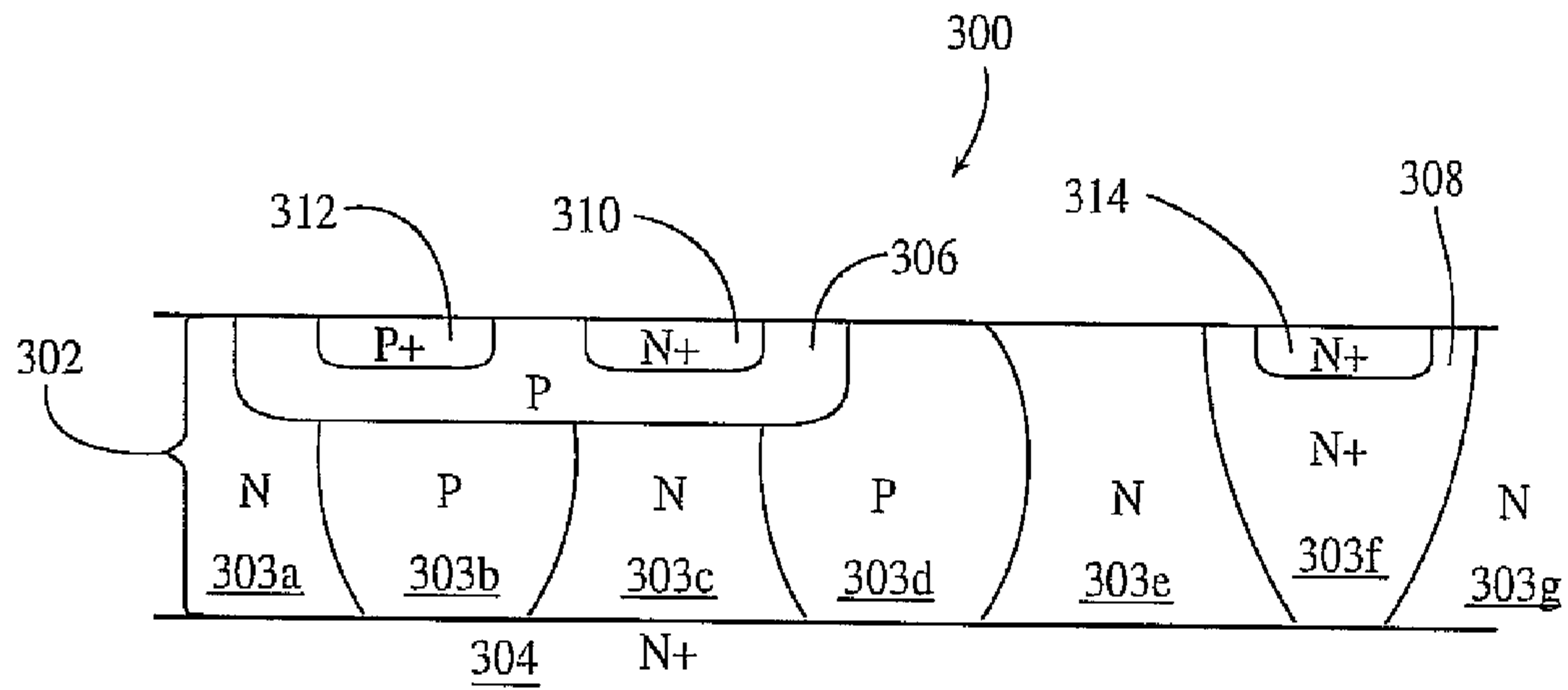

Fig 3A

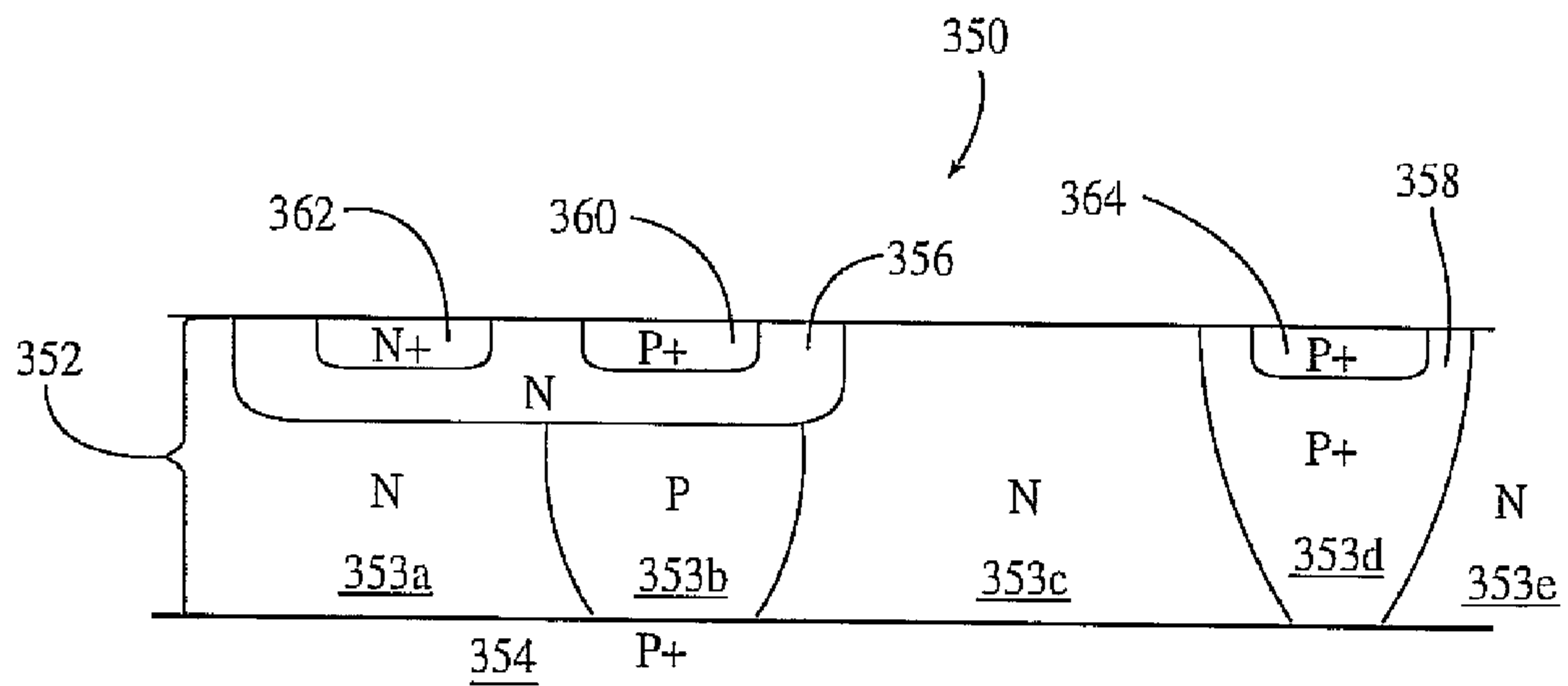
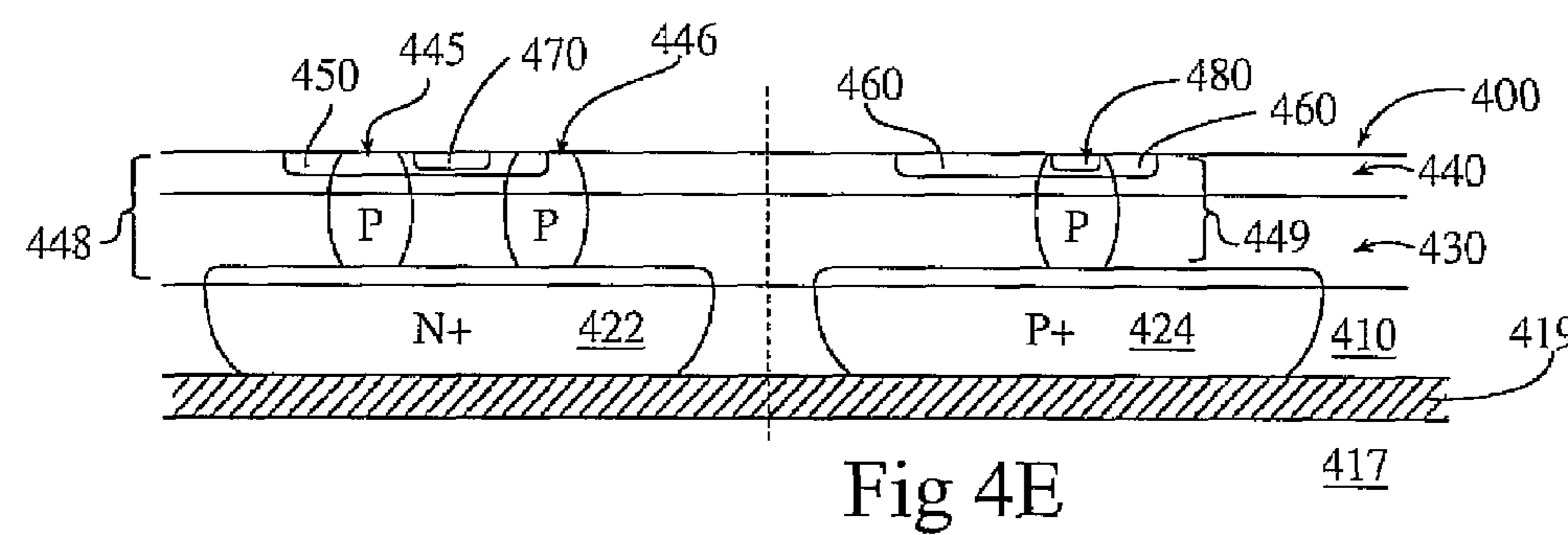
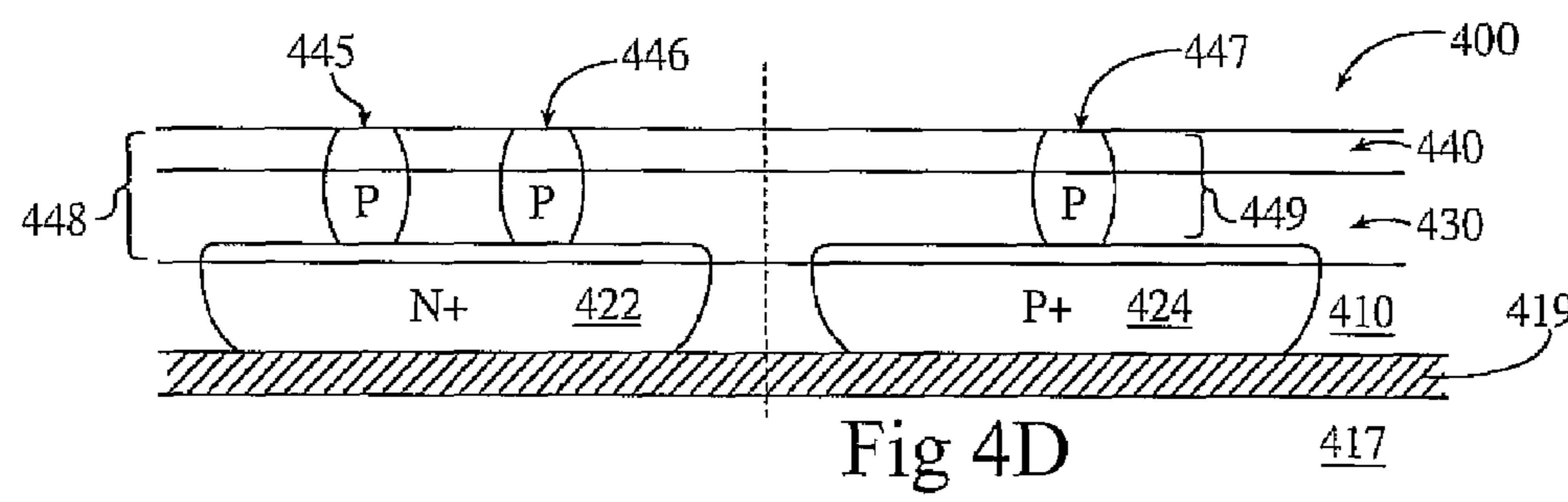
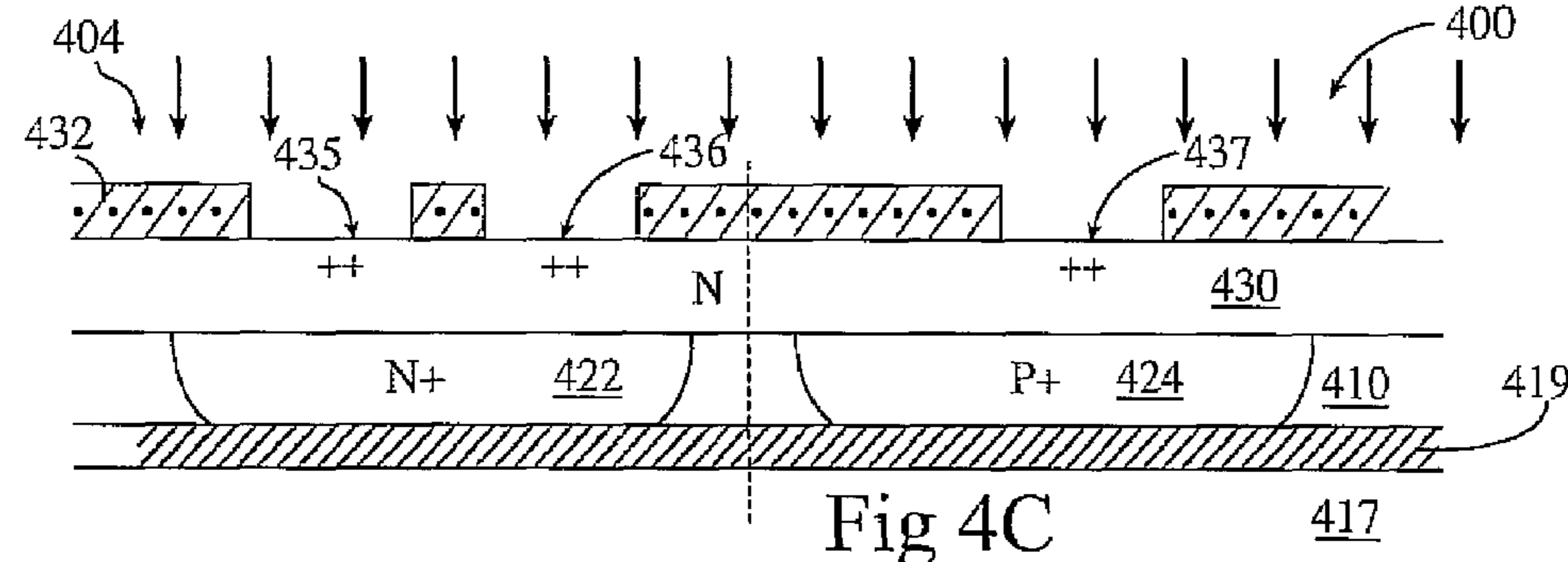
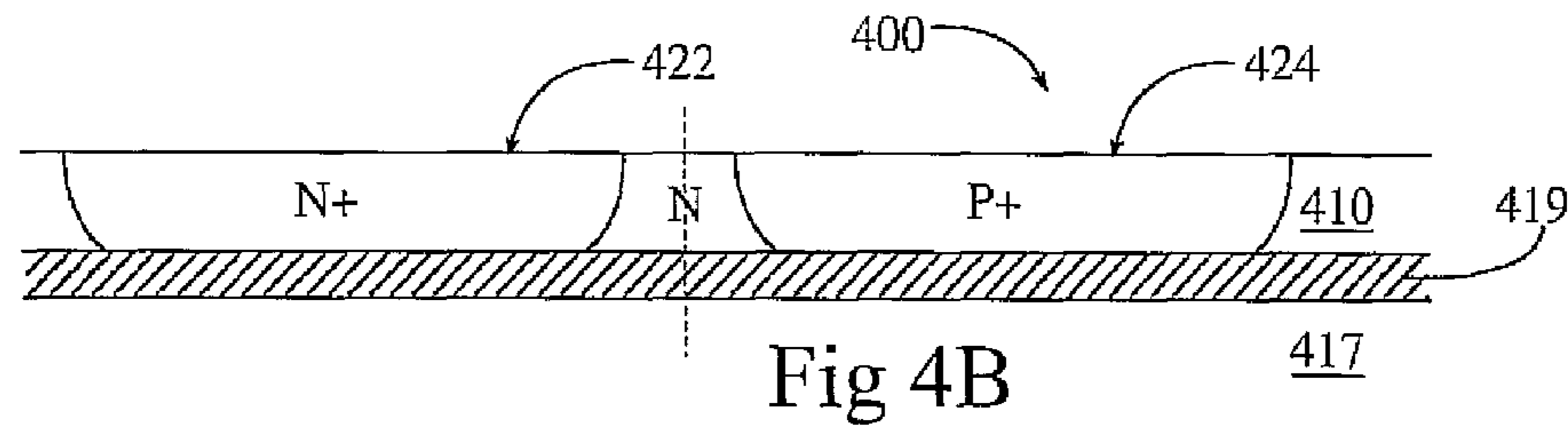
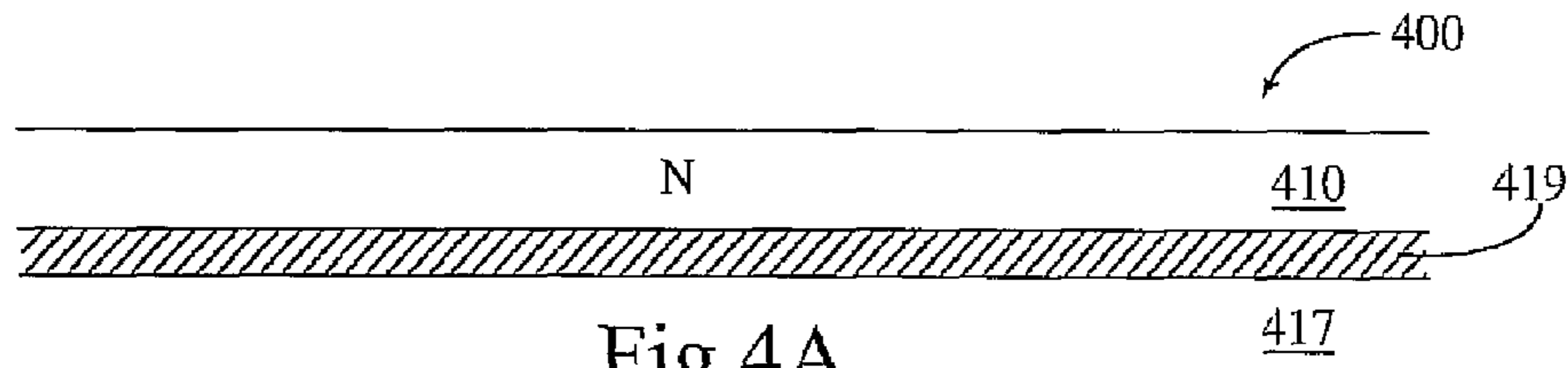

Fig 3B



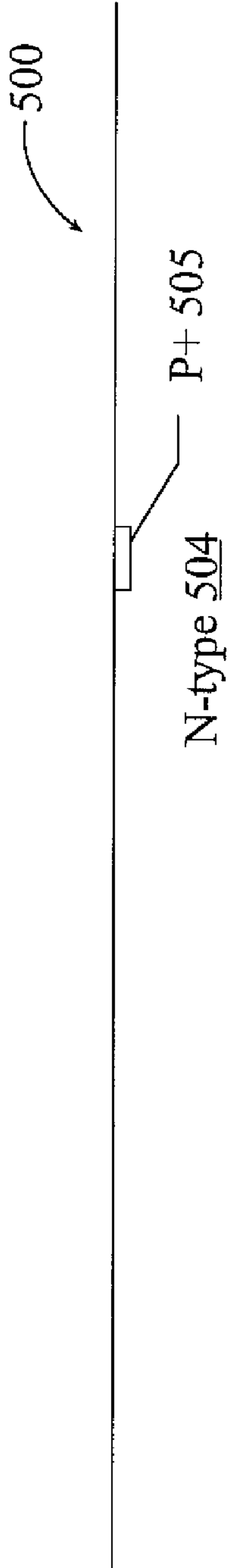

Fig 5A

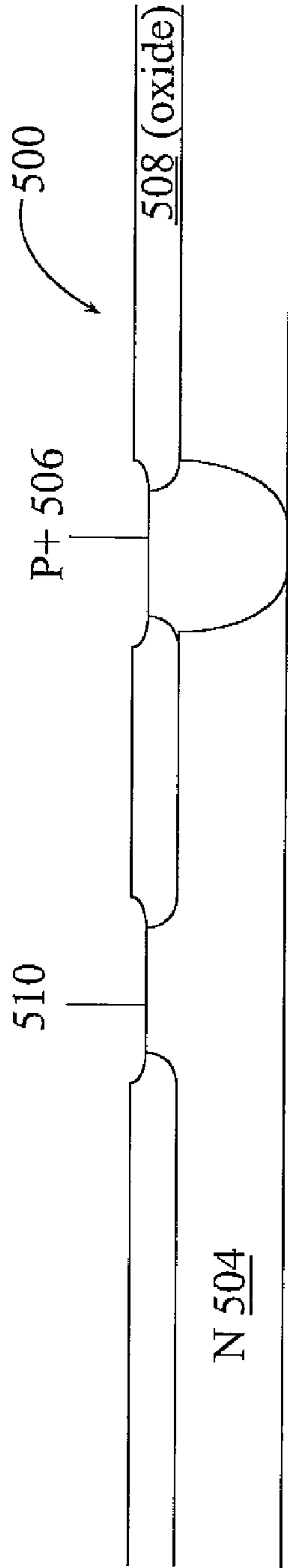

Fig. 5B

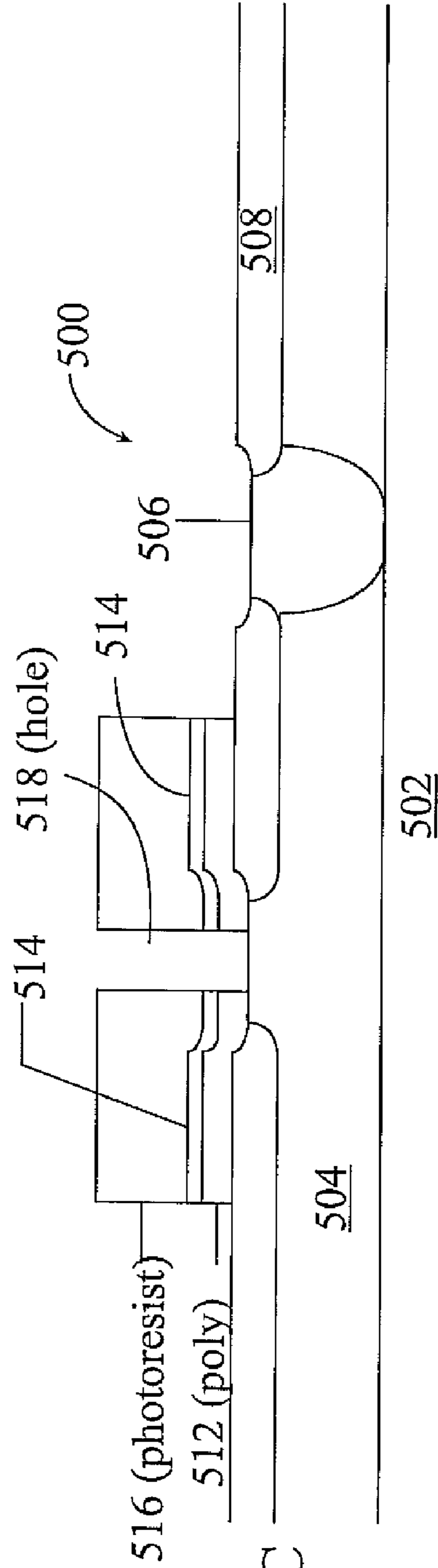

Fig. 5C

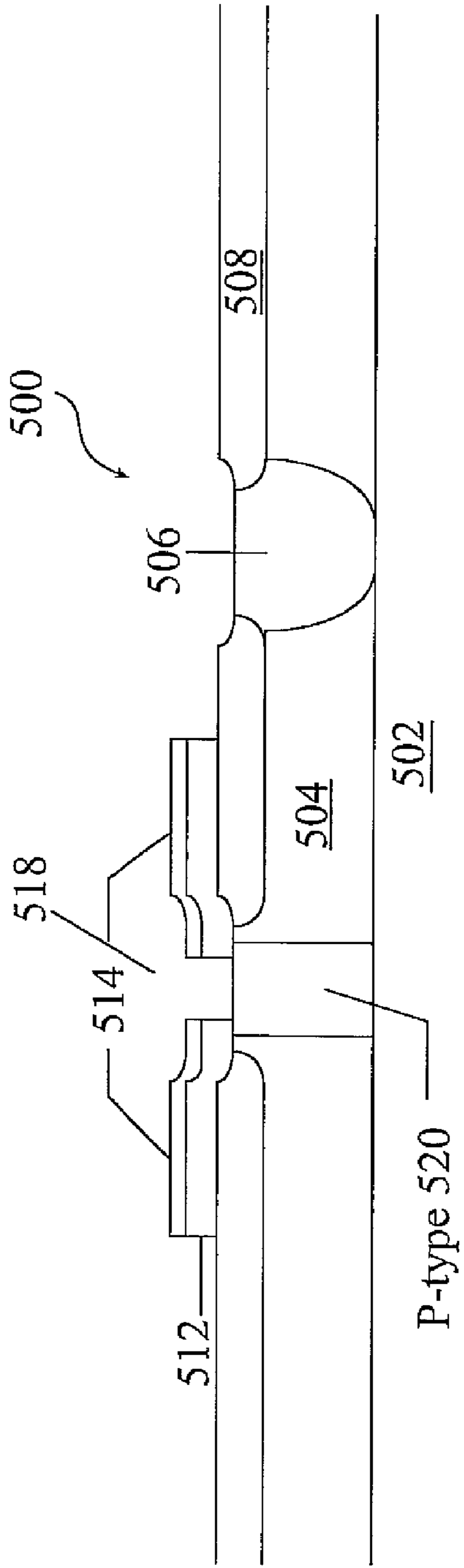

Fig. 5D

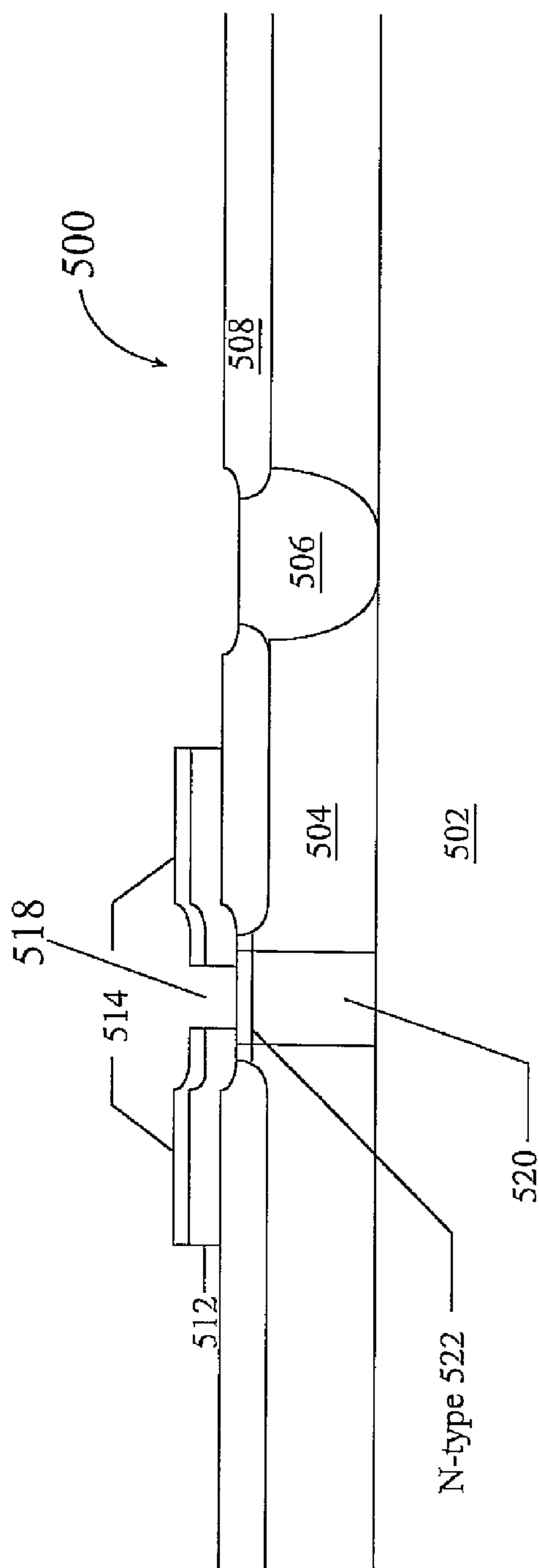

Fig. 5E

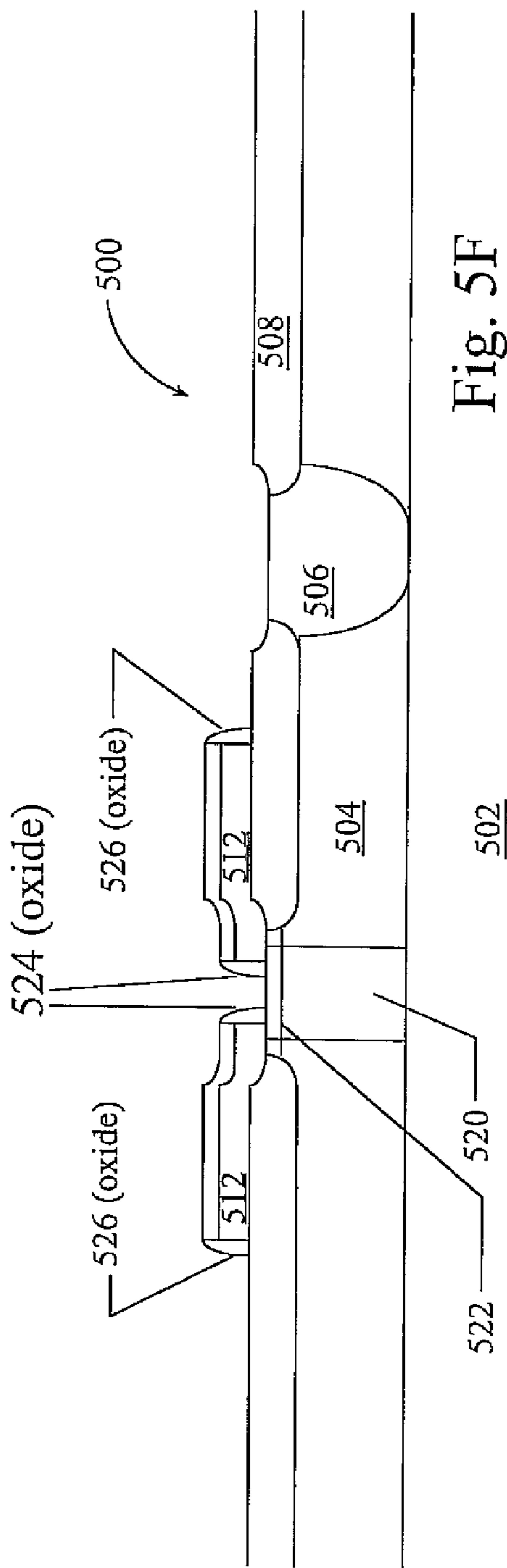

Fig. 5F

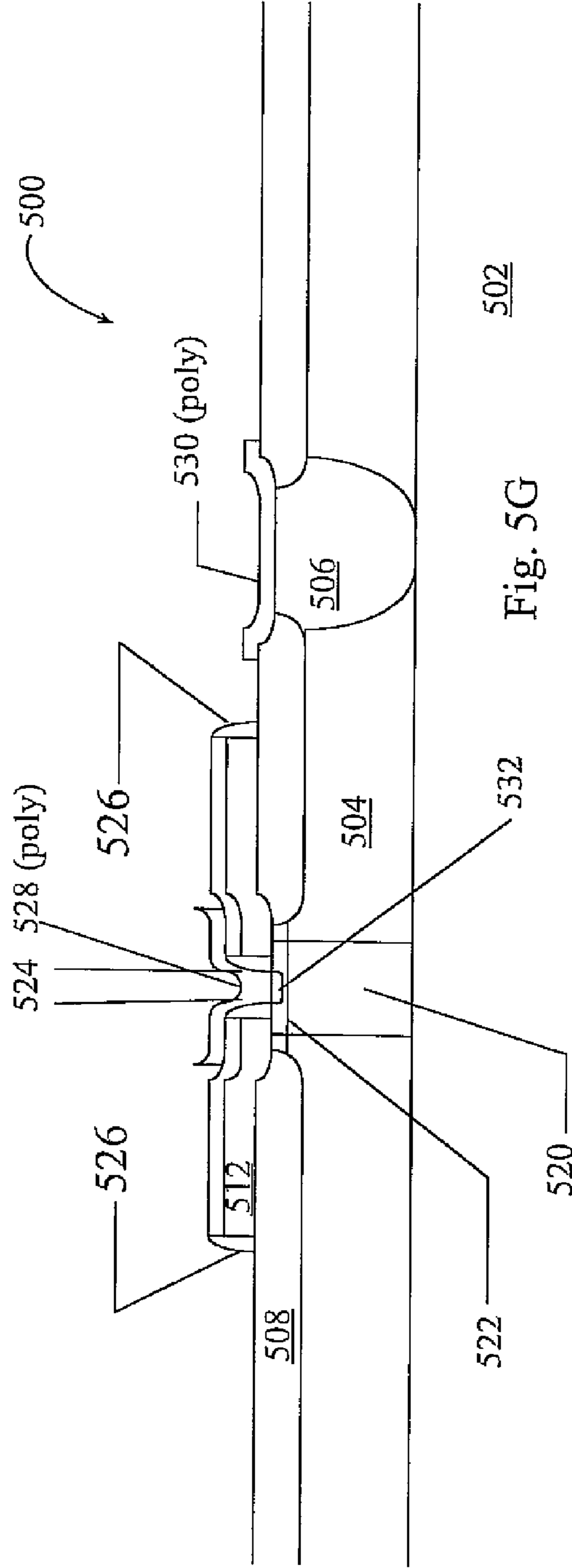

Fig. 5G

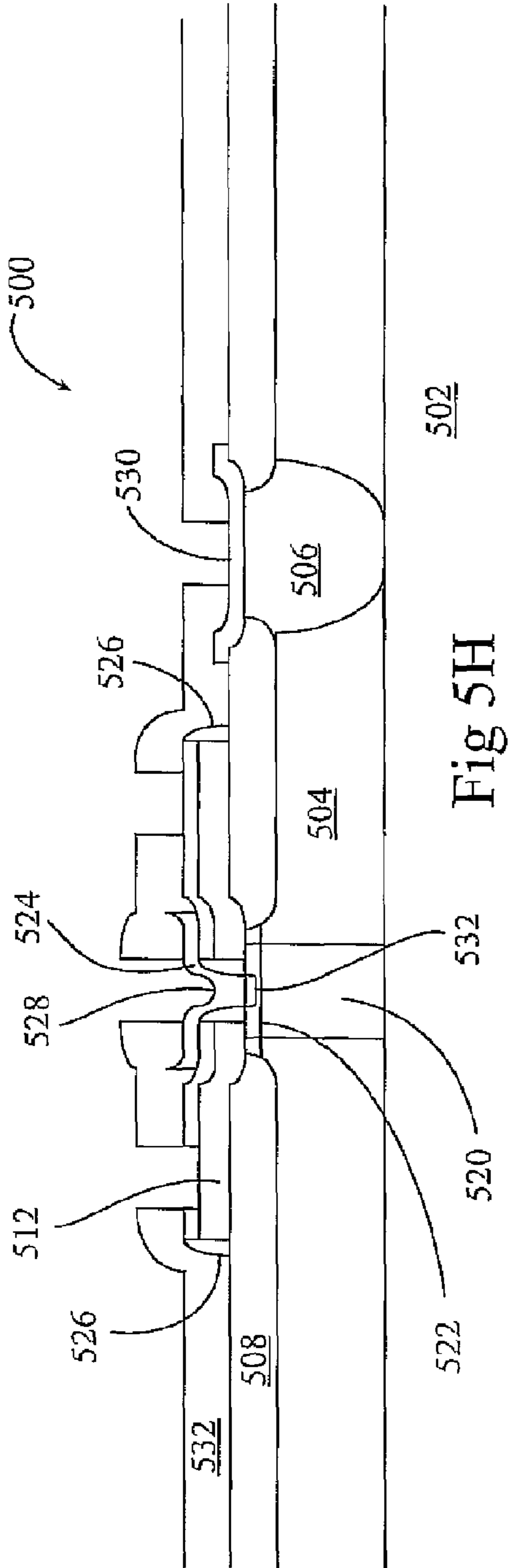

Fig. 5H

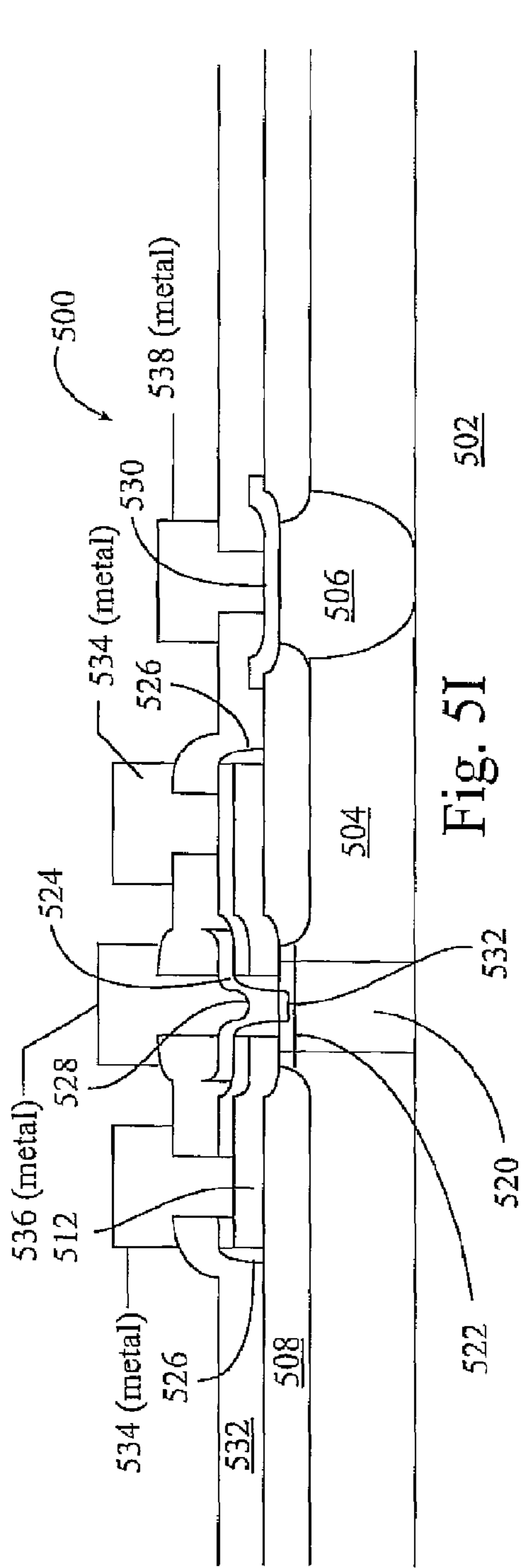
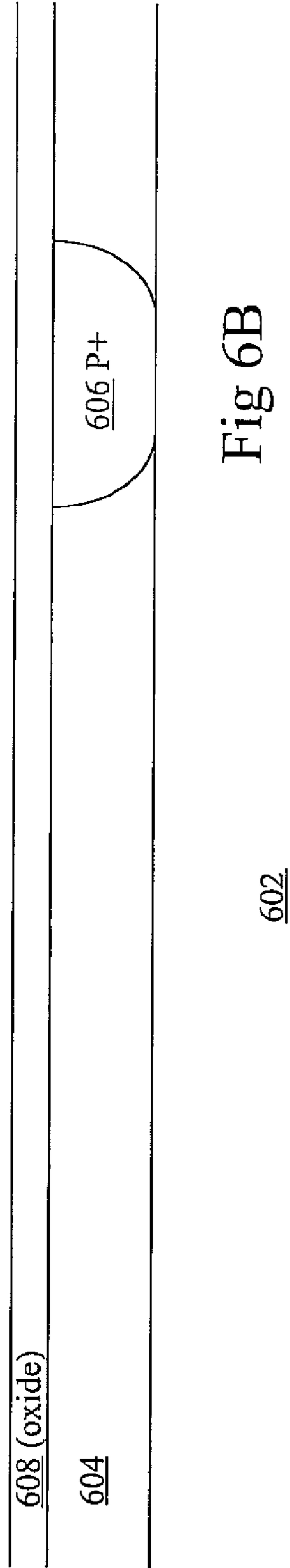
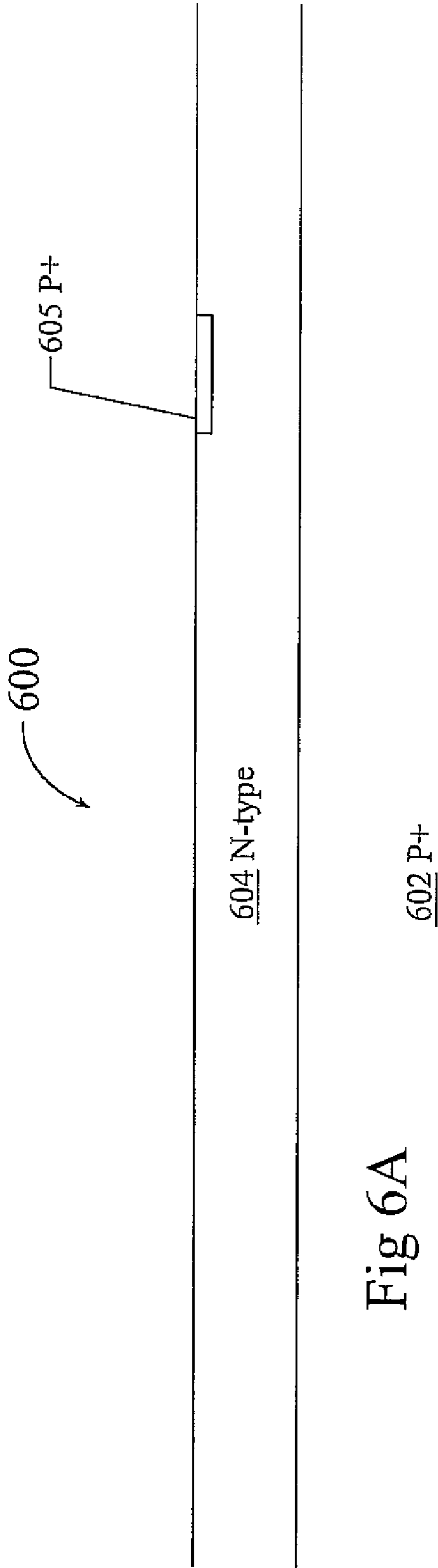

Fig. 5I



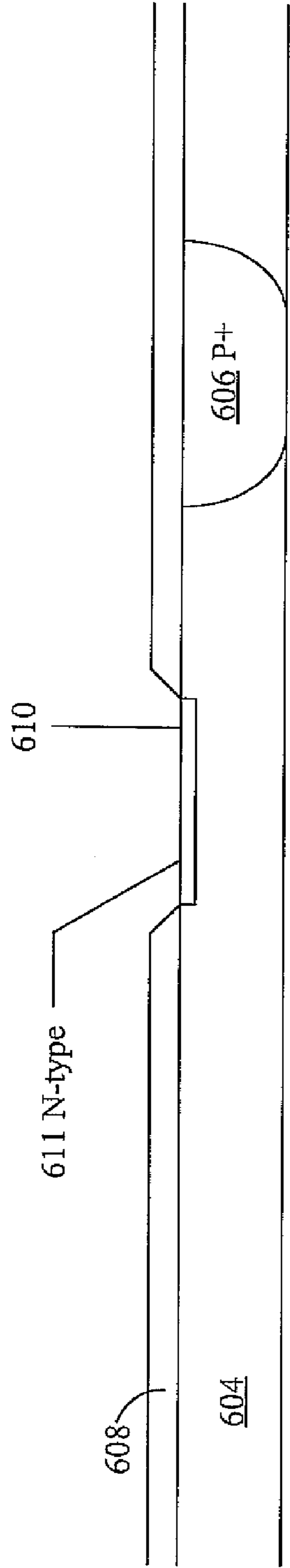

Fig 6C

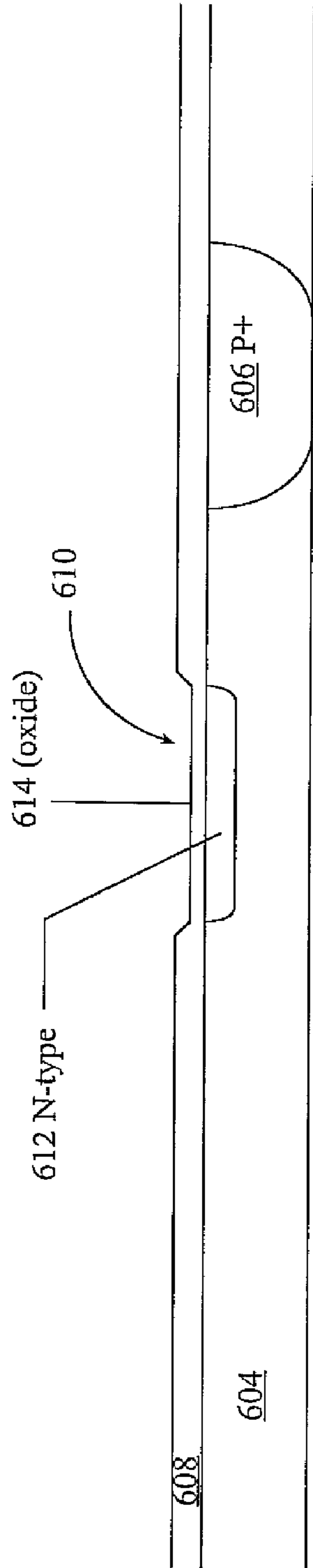

Fig 6D

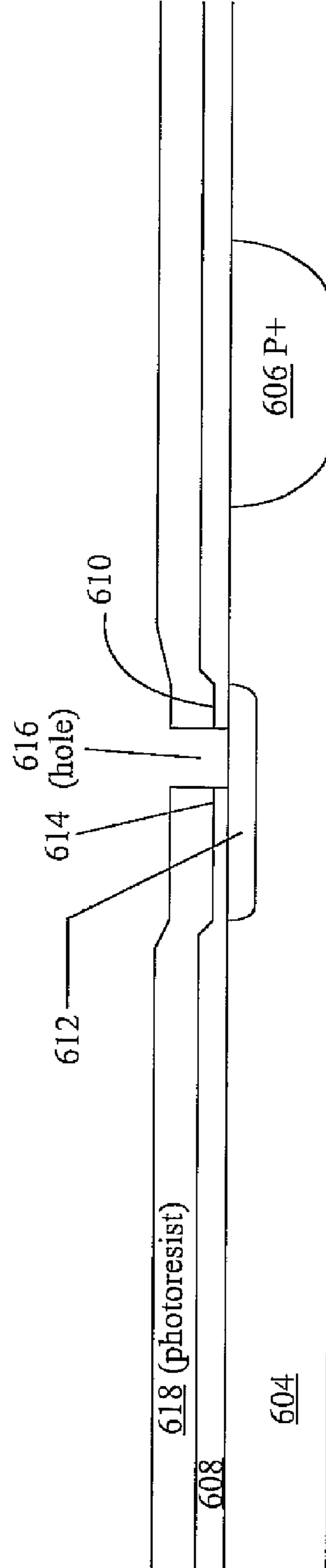

Fig 6E

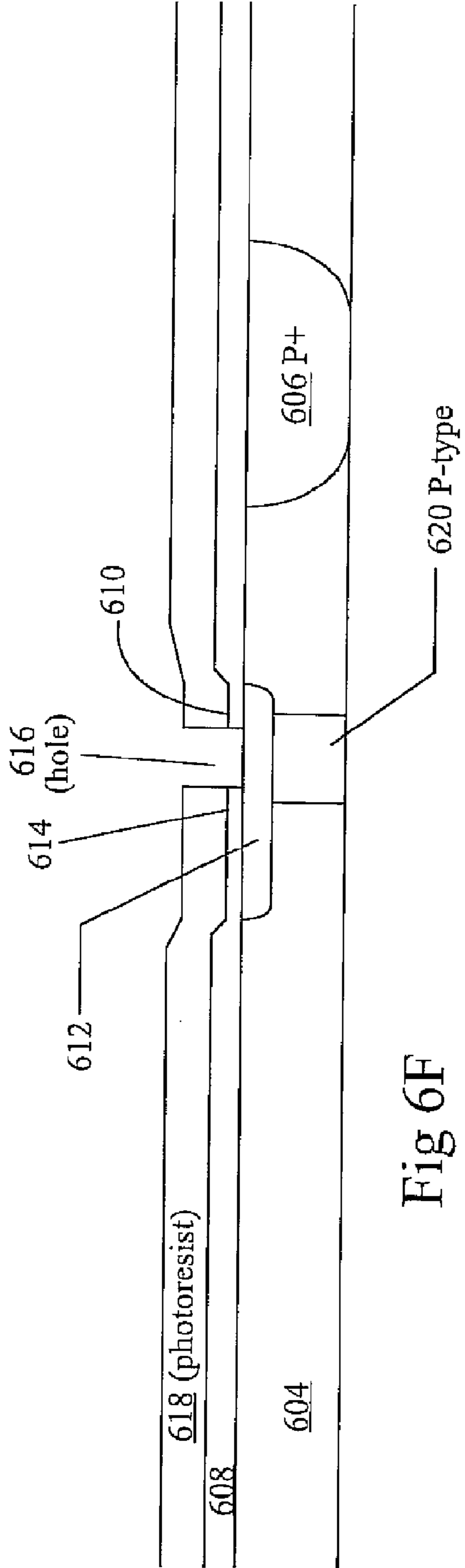

Fig 6F

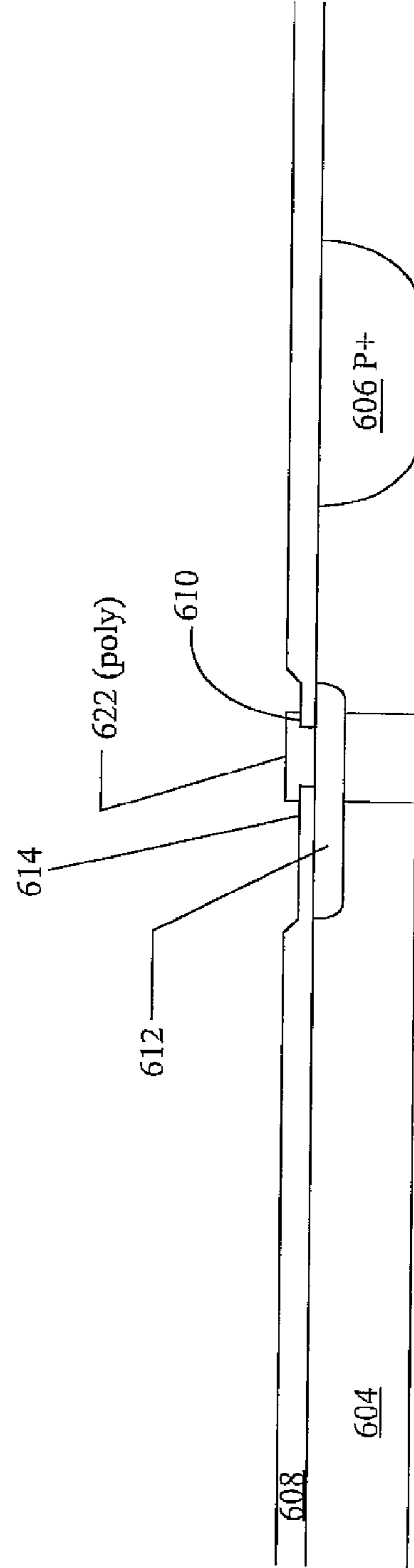

Fig 6G

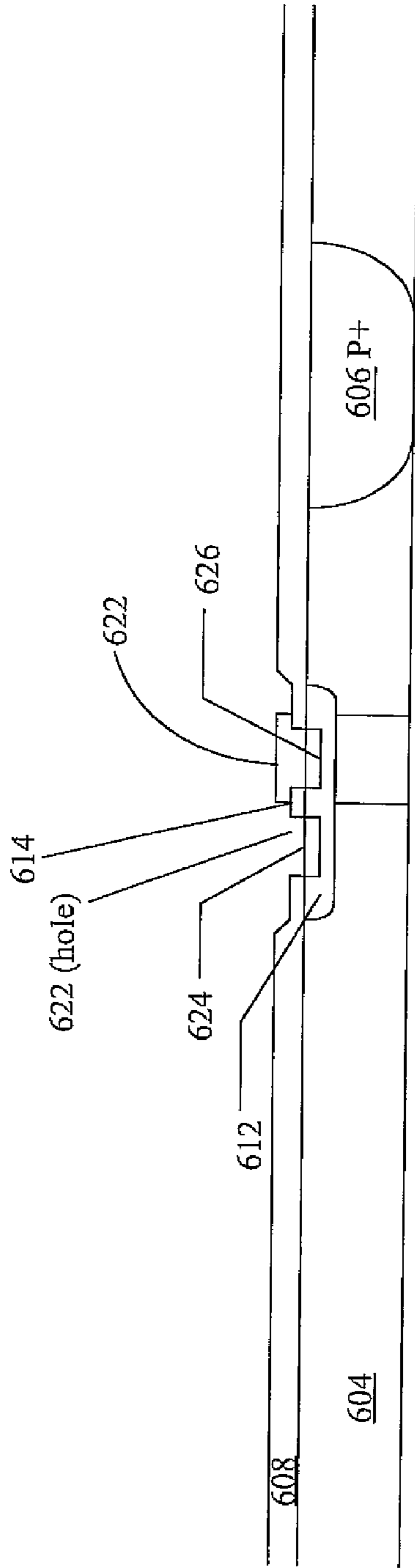

Fig 6H

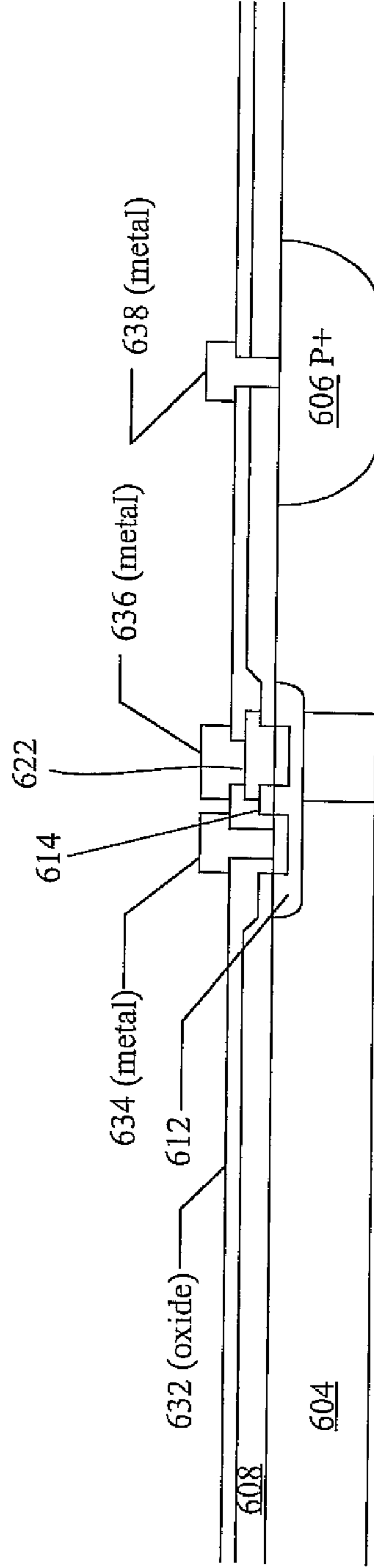

Fig 6I

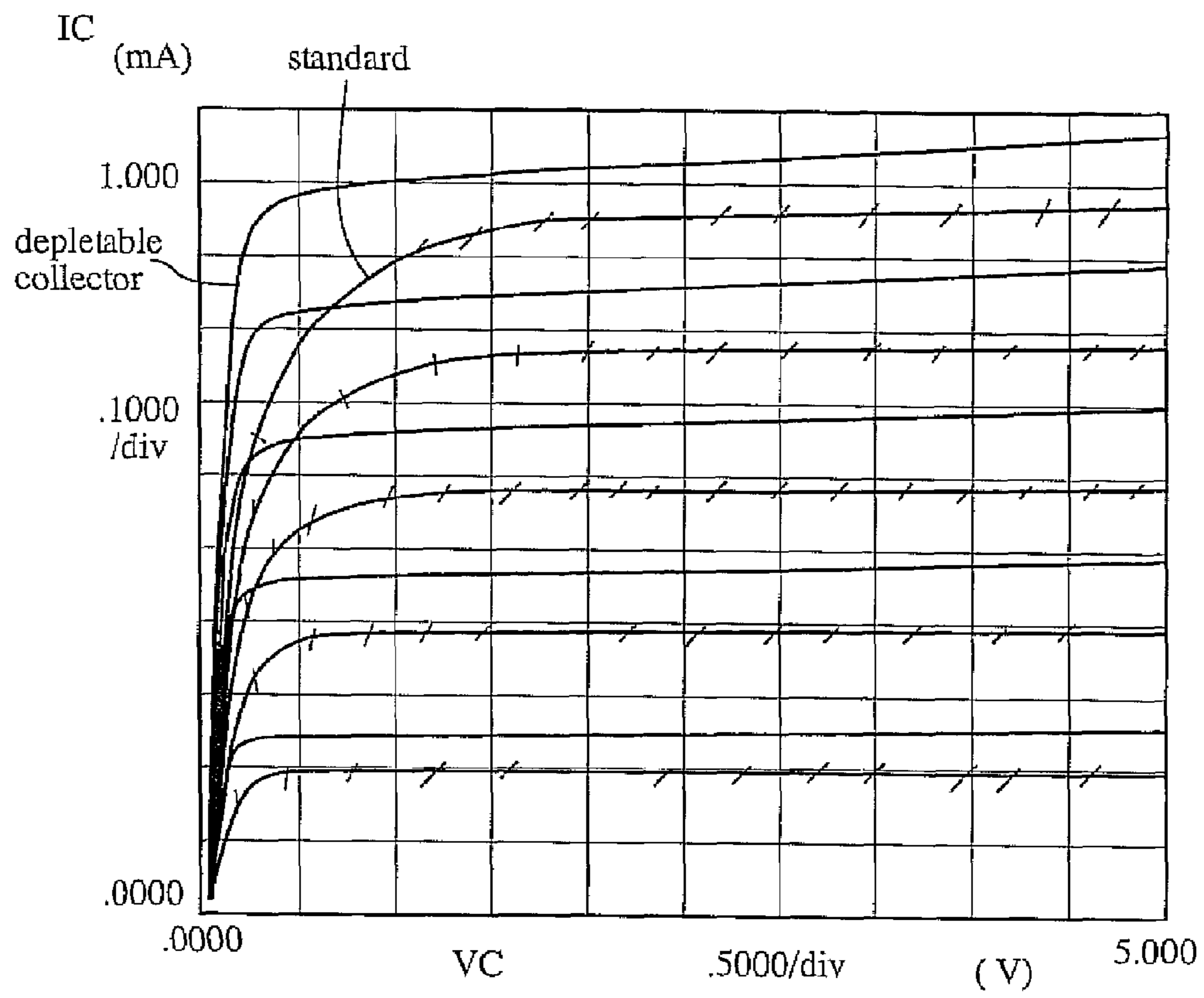

Fig 7

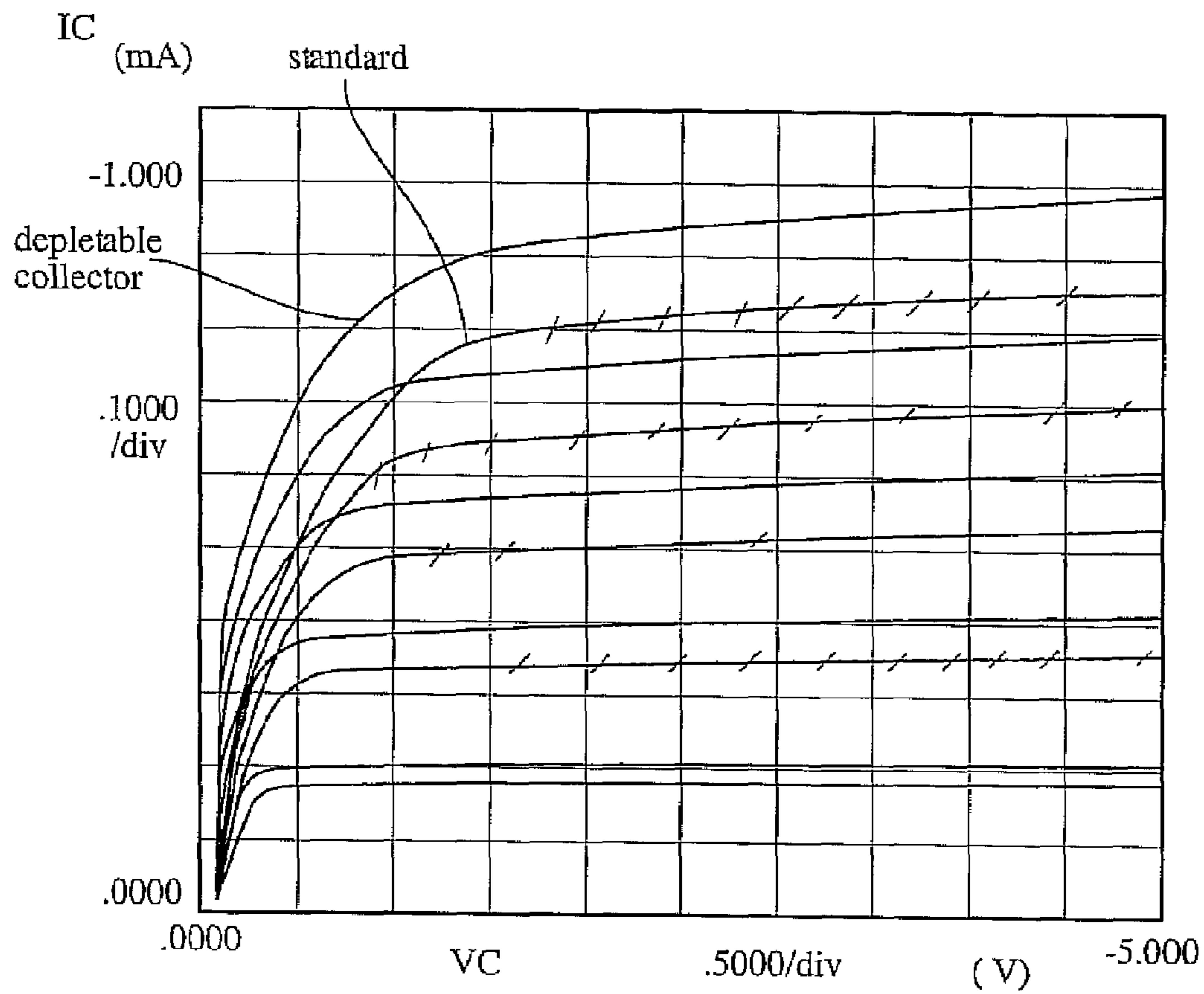

Fig 8

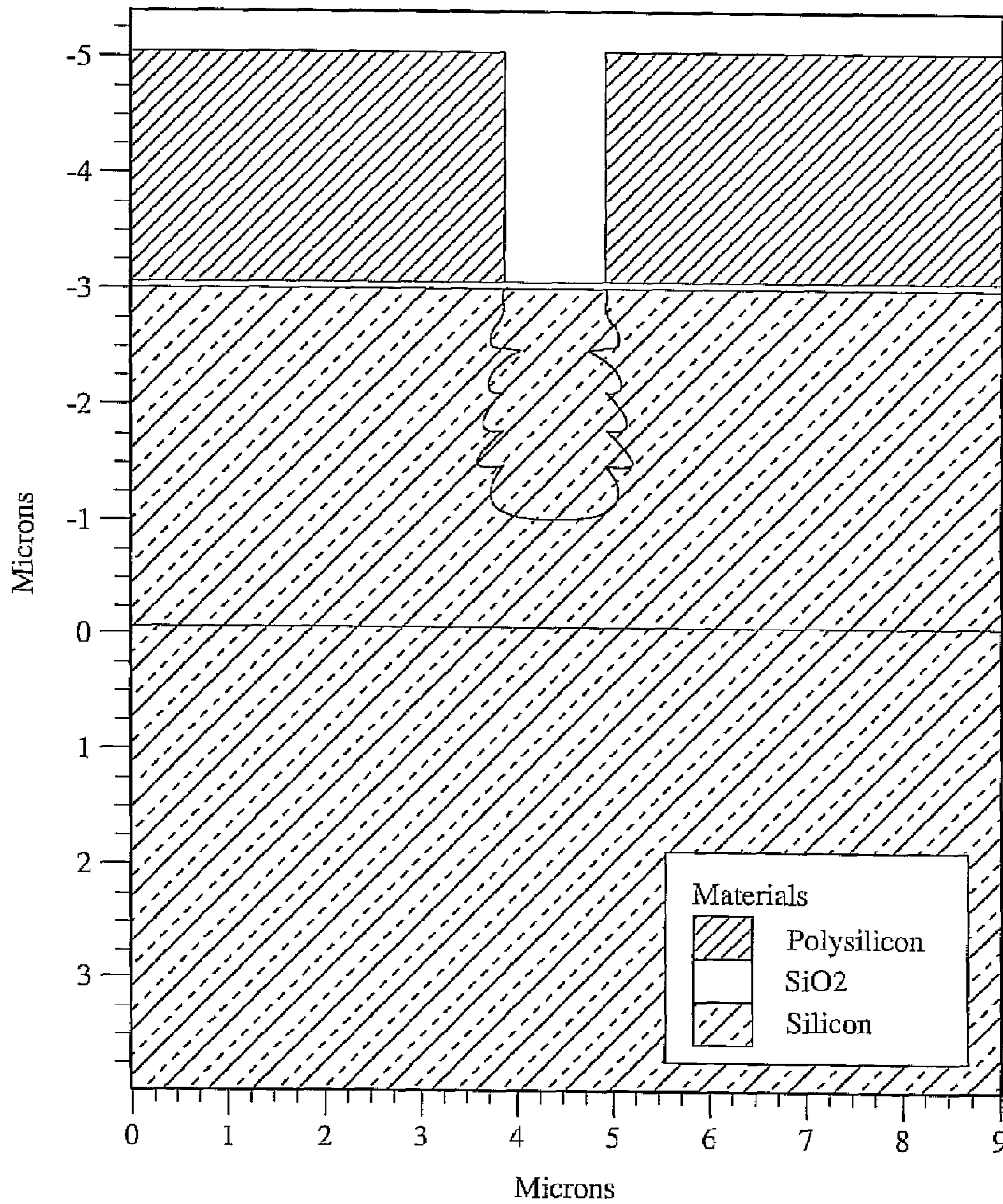

Fig 9

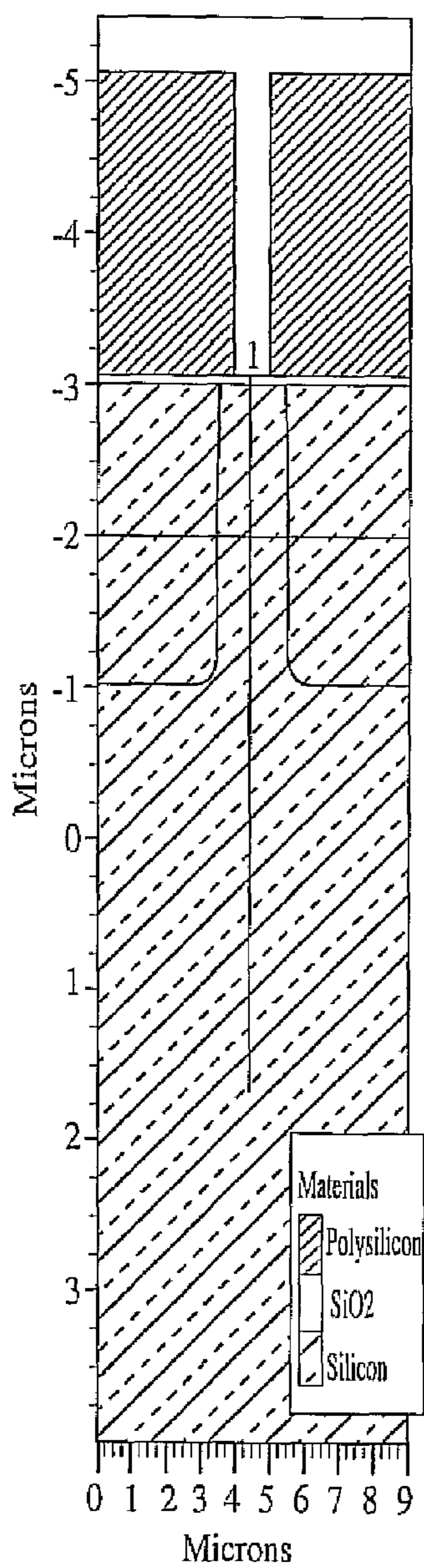

Fig 10A

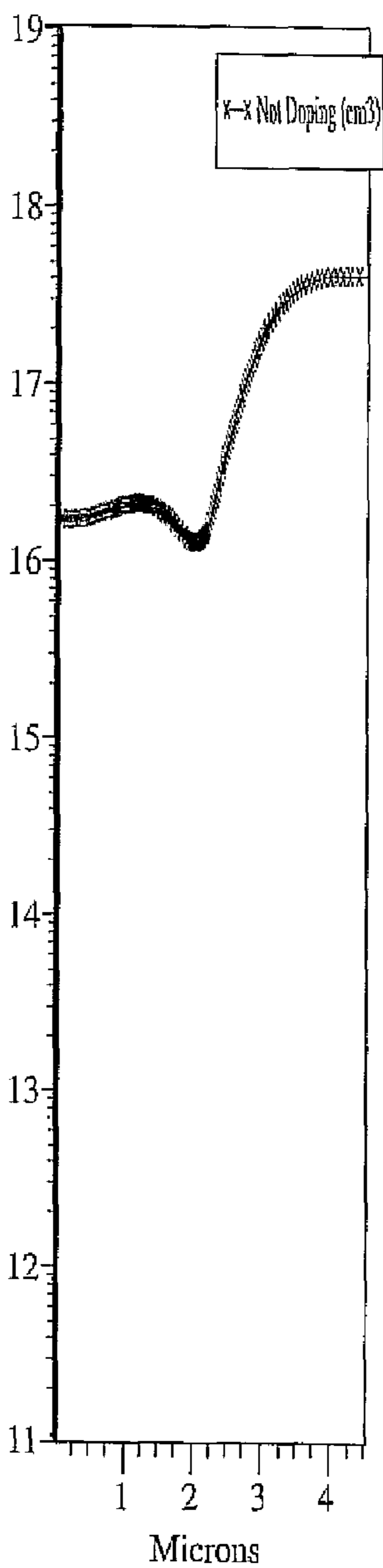

Fig 10B

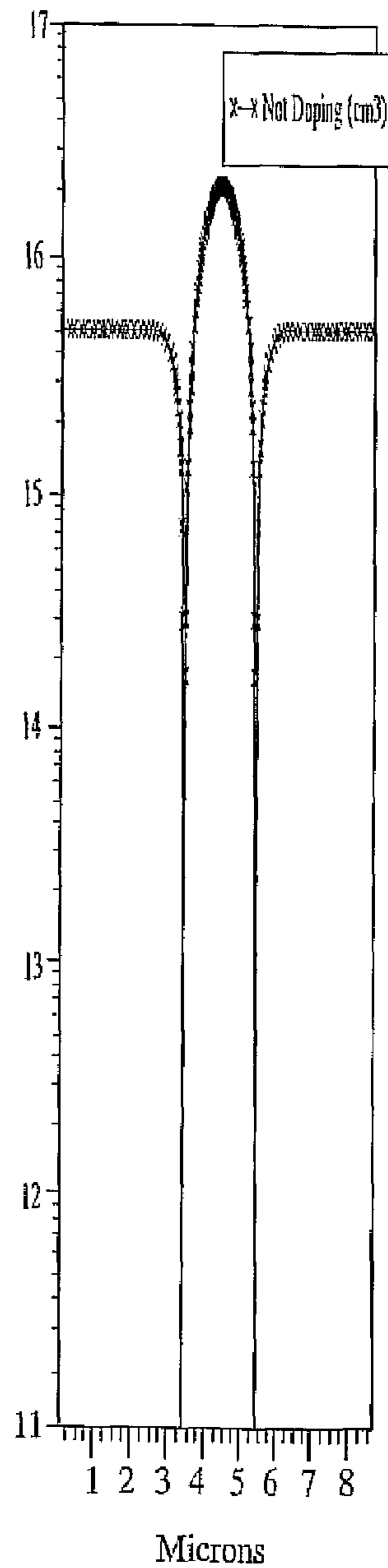

Fig 10C

**BIPOLAR METHOD AND STRUCTURE
HAVING IMPROVED BV_{CEO}/R_{CS}
TRADE-OFF MADE WITH DEPLETABLE
COLLECTOR COLUMNS**

Matter enclosed in heavy brackets [] appears in the original patent but forms no part of this reissue specification; matter printed in italics indicates the additions made by reissue.

This application is a *CON* of application Ser. No. 12/985,856 filed Jan. 6, 2011 now U.S. Pat. No. Re. 43,042 which is a division of Application Ser. No. 11/217,304, filed Sep. 2, 2005 now U.S. Pat. No. 7,285,469, the entire contents of which are incorporated herein by reference. *Notice: More than one reissue application has been filed for the reissue of U.S. Pat. No. 7,473,983. The reissue applications are application Ser. No. 12/985,856, which was filed on Jan. 6, 2011, (the parent reissue), and this divisional, reissue Application (the present, divisional, reissue application). Both reissue applications are reissues of the same U.S. Pat. No. 7,473,983. U.S. Pat. No. 7,473,983 is a division of application Ser. No. 11/217,304, which was filed on Sep. 2, 2005, and issued as U.S. Pat. No. 7,285,469 on Oct. 23, 2007.*

FIELD OF THE INVENTION

The subject matter of this application relates to integrated circuits having bipolar transistors. More particularly, the subject matter of this application relates to bipolar transistors comprising super junctions.

BACKGROUND OF THE INVENTION

Many bipolar transistors have their size set to meet a required collector resistance (R_{es}). R_{es} is proportional to collector resistivity and to the length of the collector between the base and buried layer. Thus, to minimize R_{es} , one typically minimizes both collector resistivity and collector length.

FIG. 1 shows a conventional NPN bipolar transistor **100** consisting of an N-collector **102** formed over an N+ buried layer **104**, a P base **106** and an N+ sinker **108** formed in the N-collector **102**, an N+ emitter **110** and a P+ base contact **112** formed in the P base **106**, and an N+ collector contact **114** formed in the N+ sinker **108**. In the conventional bipolar transistor, the collector **102** is doped to the same conductivity throughout. The breakdown voltages BV_{CEO} and BV_{CBO} of the conventional bipolar transistor **100** are both reduced when the resistivity of N- collector **102** is reduced. These breakdown voltages are also reduced when the length of the N-collector **102** is reduced to less than the collector depletion layer thickness at breakdown. Thus, there is a tradeoff between breakdown and R_{es} for bipolar transistors of a given size. Conventional PNP bipolar transistors typically consist of a similar structure but have inverted conductivities.

One approach to increase the breakdown of a transistor with a given collector doping is to cascade the collector with a junction field effect transistor (JFET). The area required for the JFET, however, can consume more area than is saved by reducing the collector doping in some cases so other methods and structures are desired.

Thus, there is a need to overcome these and other problems of the prior art to provide a method and a device to reduce the size of a bipolar transistor while also achieving an improved R_{es} .

SUMMARY OF THE INVENTION

In accordance with the invention, there are various methods of making an integrated circuit comprising a bipolar transistor. According to an embodiment of the invention, the bipolar transistor can comprise a substrate, a collector comprising a plurality of alternating doped regions, wherein the plurality of alternating doped regions alternate in a lateral direction from a net first conductivity to a net second conductivity, and a collector contact in electrical contact with the collector. The bipolar transistor can also comprise a heavily doped buried layer below the collector, a base in electrical contact with a base contact, wherein the base is doped to a net second conductivity type and wherein the base spans a portion of the plurality of alternating doped regions, and an emitter disposed within the base, the emitter doped to a net first conductivity, wherein a portion of the alternating doped region under the emitter is doped to a concentration of less than about $3 \times 10^{12} \text{ cm}^{-2}$.

According to another embodiment of the invention there is another integrated circuit comprising a bipolar transistor. The bipolar transistor can comprise a substrate, a base formed in the substrate, a collector comprising a doped first region doped to a net first conductivity disposed under the base, wherein the base is doped to a net second conductivity type, and doped second regions doped to a net second conductivity disposed on opposite sides of the doped first region, and a collector contact in electrical contact with the collector. The bipolar transistor can also comprise a more heavily doped layer buried below the doped first region and the doped second regions, and an emitter doped to a net first conductivity disposed within the base, wherein the doped region disposed beneath the emitter depletes at a reverse bias collector base voltage of magnitude less than an absolute value of BV_{CEO} .

According to another embodiment of the invention there is a method of forming an integrated circuit comprising a bipolar transistor. The method can comprise forming a device layer doped over a substrate, forming a buried region in the device layer, and forming a first layer doped to a net first conductivity over the device layer. The method can also comprise forming at least one second conductivity type region using a dopant material of a second conductivity type in the first layer, wherein the at least one second conductivity type region is bounded by at least one region doped to the first conductivity type, forming a base region in the first layer, and forming an emitter in a portion of the base region.

According to another embodiment of the invention there is a method of making a bipolar transistor. The method can comprise forming a device layer over a substrate, forming a buried region under the device layer, and forming a patterned layer over the device layer, wherein the patterned layer comprises an opening that exposes a portion of the device layer. The method can also comprise providing dopants of a first conductivity type to the exposed portion of the device layer to form a column of first conductivity type dopants in the device layer, providing dopants of a second conductivity type to the exposed portion of the device layer to form an intrinsic base in the device layer, forming an emitter that contacts a portion of the exposed device layer, and forming an emitter contact over the emitter.

According to another embodiment of the invention there is a method of making a bipolar transistor. The method can comprise forming a device layer over a substrate, forming a buried region under the device layer, forming a patterned insulator over the device layer, wherein the patterned insulator comprises a first opening that exposes a first portion of the device layer, providing dopants of a first conductivity type to

the exposed first portion of the device layer to form a base in the device layer, and forming a patterned base insulator over the exposed first portion of the device layer, wherein the patterned base insulator comprises a second opening that exposes an area of the first portion of the device layer. The method can also comprise providing dopants of a second conductivity type to the exposed area of the first portion of the device layer to form a column of second conductivity type dopants in the device layer, forming an emitter that contacts a portion of the exposed area of the first portion of the device layer, and forming an emitter contact over the emitter.

It is to be understood that both the foregoing general description and the following detailed description are exemplary and explanatory only and are not restrictive of the invention, as claimed.

The accompanying drawings, which are incorporated in and constitute a part of this specification, illustrate several embodiments of the invention and together with the description, serve to explain the principles of the invention.

BRIEF DESCRIPTION OF THE DRAWINGS

FIG. 1 shows a conventional NPN bipolar transistor.

FIG. 2 depicts a schematic representation of a super junction.

FIG. 3A depicts a schematic representation of an NPN bipolar transistor comprising a super junction structure according to various embodiments of the invention.

FIG. 3B depicts a schematic representation of a PNP bipolar transistor comprising a super junction structure according to various embodiments of the invention.

FIGS. 4A-4E depict schematic representations of a method for forming an integrated circuit device comprising an NPN and a PNP bipolar transistor comprising a super junction structure according to various embodiments of the invention.

FIGS. 5A-5I depict schematic representations of a method for forming an integrated circuit device comprising a PNP double polycrystalline silicon bipolar transistor architecture comprising a super junction structure according to various embodiments of the invention.

FIGS. 6A-6I depict schematic representations of a method for forming an integrated circuit device comprising a PNP single polycrystalline silicon bipolar transistor architecture comprising a super junction structure according to various embodiments of the invention.

FIG. 7 is a plot of exemplary collector resistances achieved using the super junction structures described herein in comparison to conventional collector structures.

FIG. 8 is another plot of exemplary collector resistances achieved using the super junction structures described herein in comparison to conventional collector structures.

FIG. 9 depicts an exemplary dopant profile for a super junction structure before a diffusion step.

FIGS. 10A-C depict exemplary dopant profiles for a super junction structure after a diffusion step.

DESCRIPTION OF THE EMBODIMENTS

In the following description, reference is made to the accompanying drawings that form a part thereof, and in which is shown by way of illustration specific exemplary embodiments in which the invention may be practiced. These embodiments are described in sufficient detail to enable those skilled in the art to practice the invention and it is to be understood that other embodiments may be utilized and that

changes may be made without departing from the scope of the invention. The following description is, therefore, not to be taken in a limited sense.

Notwithstanding that the numerical ranges and parameters setting forth the broad scope of the invention are approximations, the numerical values set forth in the specific examples are reported as precisely as possible. Any numerical value, however, inherently contains certain errors necessarily resulting from the standard deviation found in their respective testing measurements. Moreover, all ranges disclosed herein are to be understood to encompass any and all sub-ranges subsumed therein. For example, a range of "less than 10" can include any and all sub-ranges between (and including) the minimum value of zero and the maximum value of 10, that is, any and all sub-ranges having a minimum value of equal to or greater than zero and a maximum value of equal to or less than 10, e.g., 1 to 5.

Prior to discussing the specific features of the exemplary embodiments, a discussion of a super junction structure is provided. According to various embodiments, a super junction structure can be formed at the collector-base junction in an NPN bipolar transistor **200** and a PNP bipolar transistor **250** as shown in FIG. 2A and FIG. 2B, respectively. Generally, a super junction structure is a structure that allows the doping on the lightly doped side of a PN junction to be increased and the length of the lightly doped side to be reduced as compared to the same junction in a conventional device for a given breakdown voltage. In a bipolar transistor device, the uniform collector doping, such as that shown in conventional device **100** of FIG. 1 is replaced with alternative P and N doped columns, such as those shown in FIGS. 2A and 2B. Moreover, the doping of the columns can be matched. For example, the thickness of the P column times its doping can be equal to the thickness of the N column times its doping.

The thickness of the columns can be determined such that when the junction is reverse biased, they totally deplete before breakdown is reached. The super junction column properties can be expressed as:

$$t_N * N_D = t_P * N_A \quad [1]$$

where t_N =thickness of the N column, N_D =doping of the N column, t_P =thickness of the P column, and N_A =doping of the N column; and

$$t_{max} = 2E_{max} * \epsilon / q * N \quad [2]$$

where t_{max} =maximum thickness of the column, E_{max} =maximum electric field before breakdown occurs, ϵ =dielectric constant of the substrate, such as silicon, N =doping level of the column.

The doping of the depletable columns is disconnected from breakdown because once it depletes, a constant electric field extends the length of the column. Breakdown is approximated by:

$$BV = E_{crit} * I \quad [3]$$

where BV =breakdown voltage, E_{crit} =critical electric field for breakdown, I =length of the column.

The depletable columns of a super junction can be used to form drain regions that have shorter and higher doped layers than in conventional DMOS structures of the same breakdown voltage. In particular, they provide reduced "on" resistance in a given area.

Super junctions can also be applied to reduce R_{es} in bipolar transistor devices. Moreover, similar column structures can be used to improve both NPN and PNP bipolar transistor devices, such as when both devices are formed in the same wafer.

5

Turning to FIG. 2A, a schematic representation of an NPN bipolar transistor **200** is shown that comprises a collector, generally referred to as **202**, formed over an N+ buried layer **204**, a P base **206** and an optional N+ sinker **208** formed in the collector **202**, an N+ emitter **210** and a P+ base contact **212** formed in the P base **206**, and an N+ collector contact **214** formed in the optional N+ sinker **208**. The doping of the collector **202** comprises alternating N and P doped regions or columns **203a-i**.

In FIG. 2B, a schematic representation of PNP bipolar transistor **250** is shown that comprises a collector, generally referred to as **252**, formed over a P+ buried layer **254**, an N base **256** and an optional P+ sinker **258** formed in the collector **252**, a P+ emitter **260** and an N+ base contact **262** formed in the N base **256**, and a collector contact **264** formed in the optional P+ sinker **258**. The doping of the collector **252** comprises alternating P and N doped regions or columns **253a-i**.

As shown in FIG. 2A, at least the region under the base **206** comprises alternating N and P columns **203c-203f**. Similarly in FIG. 2B, at least the region under the base **256** comprises alternating N and P columns **253c-253f**.

The steps used to form the N and P columns can be similar for the NPN bipolar transistor device as for the PNP bipolar transistor device. For example, the NPN can be formed over an N+ buried layer, such as N+ buried layer **204**, and the PNP can be formed over a P+ buried layer, such as P+ buried layer **254**. Further, the collector contact **214** can be formed in an N column, such as **203h**. Alternatively an optional N+ sinker, such as sinker **208**, can be formed through N and/or P columns, such as columns **203g** and **203h**, to connect the buried layer to the surface of the device. The PNP collector contact can be formed in a similar manner to that of the NPN but with the conductivity types inverted.

In prior art super junctions, the integrated doping of the P and N columns may require matching. According to various embodiments of the invention, there is provided a super junction structure that relaxes the matching requirements while at the same time, retaining the R_{es} improvement, at least for bipolars designed to meet a required BV_{CEO} .

According to various embodiments, a bipolar transistor device can be provided that comprises a super junction structure comprising at least one depletable column of a first conductivity type located under an emitter. The depletable column can be formed adjacent to at least one column doped to a second and opposite conductivity type. According to various embodiments, second conductivity type columns can be formed adjacent to each side of the depletable column. The adjacent columns can have doping high enough so that these columns do not totally deplete under reverse bias.

For example, the column under the emitter can be designed to deplete at a reverse bias voltage applied to the collector and the base with a magnitude that is less than the absolute value of BV_{CEO} . Moreover, in contrast to conventional structures, structures described herein can comprise columns (such as P-type columns) of opposite conductivity adjacent to collector columns (such as an N-type column) located below the emitter. According to various embodiments, a depletion layer can spread out from the vertical junction between P-type and N-type columns when the collector base junction is reverse biased. The thickness and doping of the N-type column can be determined using equations 1 and 2 described herein to insure that the N-type column totally depletes. This is also in contrast to conventional structures that cannot provide similar depletion across the entire length of the collector from a vertical junction. Conventional structures can only deplete from the horizontal junction between the base and the collec-

6

tor. And in some embodiments, the depletable column can be designed to totally deplete before BV_{CEO} occurs in the column.

According to various embodiments, the depletion characteristics of the columns can be achieved by controlling the doping of the column under the emitter. As discussed above, the depletable column under the emitter doped to the first conductivity and the columns of the second conductivity can be formed adjacent to the column under the emitter. According to various embodiments, the doping in a horizontal direction between the adjacent second conductivity type columns can be less than about $3E12$ atoms/cm². In some cases, this doping can be less than about $1E12$ atoms/cm². This doping can be derived using equation [2] for t_{max} shown above using a suitable E_{max} . It is to be noted that E_{max} can be a slowly decreasing function of breakdown voltage. As such, there may not be a single solution for all voltages.

According to various embodiments of the invention, the length of the columns can be controlled to provide a given breakdown voltage. For example, the general length of the depletable column under the emitter, between the base and the buried layer, can be determined by BV_{CEO} . Thus, the length of column can be determined using equation [3] above. In an exemplary embodiment, E_{crit} may be $2E5$ V/cm. It is to be noted that E_{crit} can decrease slowly as the voltage increases so the results obtained from equation [3] may slightly underestimate the minimum attainable voltage for low voltage (erg., about 30 V) devices. However, this calculation can be used as a general guide line to determine the length of the base to the buried layer.

FIGS. 3A and 3B depict NPN and PNP bipolar transistor devices **300** and **350**, respectively, having super junction structures such as those described herein. In FIG. 3A, the NPN bipolar transistor **300** comprises a collector, generally referred to as **302**, formed over an N+ buried layer **304**, a P base **306** and an optional N+ sinker **308** formed in the collector **302**, an N+ emitter **310** and a P+ base contact **312** formed in the P base **306**, and a collector contact **314** formed in the optional N+ sinker **308**. NPN bipolar transistor **300** can also comprise alternating P and N doped regions or columns (labeled **303a-e**). Moreover, NPN bipolar transistor **300** can comprise alternating N and N+ regions (**303e-g**), which can be considered a single N-type column.

In FIG. 3B, the PNP bipolar transistor **350** comprises a collector, generally referred to as **352**, formed over a P+ buried layer **354**, an N base **356** and an optional P+ sinker **358** formed in the collector **352**, a P+ emitter **360** and an N+ base contact **362** formed in the N base **356**, and a collector contact **364** formed in the optional P+ sinker **358**. PNP bipolar transistor **350** can also comprise alternating N and P doped regions or columns (labeled **353a-e**).

According to various embodiments, the NPN bipolar transistor **300** and the PNP bipolar transistor **350** comprise depletable columns **303c** and **353b**, respectively, under the emitters **310** and **360**, respectively. The depletable columns **303c** and **353b** are bounded on two sides by opposite conductivity type columns, such as **303b** and **303d**, and **353a** and **353c**, respectively, that do not totally deplete. This is in contrast to conventional superjunction structures that can have alternating P and N columns all of which totally deplete. Moreover, the embodiments of the present invention described herein require fewer columns than conventional devices.

According to various embodiments, the layers that are used to make the columns shown in FIG. 3A and FIG. 3B can also be used to make collectors of conventional structure bipolar devices, such as those shown in FIG. 1, that have a lower

BV_{CEO} and that are formed on other areas of the integrated circuit. Thus, it is possible to use common process steps to make two sets of bipolar devices having two different breakdown voltages.

An integrated circuit device having multiple bipolar transistors devices comprising a super junction structure, where one of the columns of the super junction structure is self-aligned to the emitter is contemplated. An example of forming such an integrated circuit device is shown in FIGS. 4A-4E. Further, a method of forming a double polycrystalline silicon ("polysilicon" or "poly") bipolar transistor architecture is shown in FIGS. 5A-5I and a method of forming a single poly transistor architecture is shown in FIGS. 6A-6I. The bipolar transistors can comprise a depletable column of the super junction structure that is self-aligned to the emitter. Moreover, various methods of making bipolar transistor devices, some of which are described herein, comprise the use of multiple ion implantations at various energies to form the collector columns without the use of multiple epitaxial collector layer depositions.

As stated above, a depiction of a method for forming NPN and PNP bipolar transistors devices comprising super junction structures on the same integrated circuit is shown in FIGS. 4A-4E. In FIG. 4A, a device layer 410, such as an N-type epitaxial layer, can be formed over a substrate 415. According to various embodiments, the device layer 410 can have a thickness in the range of about 2 μm to about 15 μm . The substrate 415 can comprise a semiconductor wafer 417, such as silicon, and a bond oxide 419. According to various embodiments, the device layer 410 can be bonded to the semiconductor wafer 417 with the bond oxide 419 to facilitate handling.

In FIG. 4B, heavily doped N+ and P+ buried regions 422 and 424 can be formed in the device layer 410. According to various embodiments, the heavily doped N+ buried region 422 can be formed by masking and ion implanting N-type ions into a portion of the device layer 410. Similarly, the heavily doped P+ buried region 424 can be formed by masking and ion implanting P-type ions into another portion of the device layer 410. Heavily doped N+ buried region 422 can serve as the buried region for the NPN device and heavily doped P+ buried region 424 can serve as the buried region for the PNP device. According to various embodiments, the N+ buried region 422 can be made by implanting phosphorous (or another N-type dopant) with an energy of about 70 KeV to about 130 KeV and a dose of about $8\text{E}14$ ions/cm² to about $3\text{E}15$ ions/cm². In still further embodiments, the N+ buried region 422 can be made by implanting phosphorous (or another N-type dopant) with an energy of about 100 KeV and a dose of about $1\text{E}15$ ions/cm². According to various embodiments, the P+ buried region 424 can be made by implanting BF_2 (or another P-type dopant) with an energy of about 20 KeV to about 40 KeV and a dose of about $8\text{E}14$ ions/cm² to about $3\text{E}15$ ions/cm². In still further embodiments, the P+ buried region 424 can be made by implanting BF_2 (or another P-type dopant) with an energy of about 30 KeV and a dose of about $1\text{E}15$ ions/cm². According to some embodiments, buried regions 422 and 424 can be formed using a diffusion process.

As shown in FIG. 4C, a first epitaxial layer 430 is formed over the device layer 410. According to various embodiments, the first epitaxial layer 430 can be doped N-type. Subsequently, the first epitaxial layer 430 can be masked and implanted with dopants that will form the collector. For example, the first epitaxial layer 430 can be masked, shown for example with mask layer 432, to allow P-type ions 434 to be implanted into regions 435 and 436 of the first epitaxial

layer 430 above the buried region 422 when the first epitaxial layer 430 is doped N-type. The mask layer 432 can also be defined to allow P-type ions 434 to be implanted into one region 437 of the first epitaxial layer 430 above the buried region 424 when the first epitaxial layer 430 is doped N-type. According to various embodiments, the P-type ions, such as boron or the like, can be implanted with an energy from about 150 KeV to about 220 KeV and a dose from about $1\text{E}12$ ions/cm² to about $1\text{E}13$ ions/cm². In still further embodiments, the P-type ions, such as boron or the like, can be implanted with an energy of about 180 KeV and a dose of about $5\text{E}12$ ion/cm². According to various embodiments, the dose can be chosen so as to provide the appropriate doping required for the desired breakdown voltage after the ions are diffused.

As shown in FIG. 4D, a second epitaxial layer 440 can be formed over the first epitaxial layer 430. According to various embodiments, the second epitaxial layer 440 can be doped N-type. Portions of the first epitaxial layer 430 and the second epitaxial layer 440 form the region that will be, generally, collector 448 and collector 449, in the NPN and PNP bipolar transistors, respectively. Subsequently, the integrated circuit 400 can be heated to allow the dopants 434 implanted into regions 435, 436, and 437 to diffuse and form the P-type columns 445, 446 in the NPN collector 448 and to form P-type column 447 in the PNP collector 449. According to various embodiments, the NPN collector 448 doping can be from about $1\text{E}15$ ions/cm² to about $5\text{E}16$ ions/cm². For a BV_{CEO} of about 70V, a doping of about $2\text{E}15$ ions/cm² can be used. Further, the columns 445 and 446 can have a length of about 5 microns and a thickness of about 8 microns for a device having a BV_{CEO} of about 70V. Moreover, equations 1 and 2, as set forth herein, can be used to set the length and thickness for a desired breakdown voltage. Still further, the thickness of the column under the emitter can be greater than the similar dimension of the emitter above it so that substantially the entire emitter lies above a collector column of like conductivity type. According to various embodiments, the PNP collector 449 doping can be from about $1\text{E}15$ ions/cm² to about $1\text{E}17$ ions/cm² and in some embodiments, about $4\text{E}15$ ions/cm². Further, for a device with a BV_{CEO} of about 70V, the column 447 can have a length of about 4 microns and a thickness of about 4 microns. Moreover, equations 1 and 2, as set forth herein, can be used to set the length and thickness for a desired breakdown voltage. Still further, the thickness of the column under the emitter can also be greater than the similar dimension of the emitter above it so that substantially the entire emitter can lie above a collector of like conductivity type.

According to various embodiments, the N-type columns of the transistors can be formed from the two N-type epitaxial layers 430 and 440. Further, the P-type columns can be formed from the P-type implant into the epitaxial layers 430 and 440. Moreover, the P-type implant is diffused down to the N+ and P+ buried regions 422 and 424, respectively, and up through the second N epitaxial layer 440 after it is deposited. While the figures show two columns formed in the NPN collector 448 and one column formed in the PNP collector 449, it is to be understood that more columns can be formed. Moreover, the above described procedure can be carried out multiple times.

As shown in FIG. 4E, a P-type base 450 is formed in the NPN collector 448 and an N-type base 460 is formed in the PNP collector 449. To form the base 450, the surface can be masked by a first mask (not shown) and P-type ions can be implanted to form the P-type base 450. Similarly, the surface can be masked, either by the first mask or by a second mask

(not shown) and N-type ions can be implanted to form the N-type base **460**. Subsequently, an N-type emitter **470** can be formed in the P-type base **450** and a P-type emitter **480** can be formed in the N-type base **460**. An N column, which is a depletable column, thus forms directly below the emitter **470**. Similarly, a P column, which is a depletable column, forms directly below the emitter **480**.

According to various embodiments, the integrated circuit can continue being processed according to procedures known to one of ordinary skill in the art. For example, an interlevel dielectric layer can be formed, contact holes can be patterned, and the various components can be electrically connected as required. Moreover, additional NPN and PNP bipolar devices, such as conventional devices of FIG. **1** can be formed on the same integrated circuit. This allows bipolar transistors having different breakdown voltages to be formed on the same device.

According to various embodiments, a double poly transistor architecture having a super junction structure is provided. The double poly transistor architecture comprising a collector having a super junction structure as described herein can be formed. Several options exist for masking the collector implants. According to various embodiments, the columns of the super junction structure can be formed by a series of implants at different energies made through an opening in a base poly. For example, an opening can be formed that exposes the emitter regions through the base poly and the collector is implanted through the opening. Outside edges of the base poly can be patterned in a subsequent step using conventional photoresist masks. Alternatively, the base poly can be patterned with a single mask to leave a pattern such that the stack of the base poly and overlying layer of oxide is thick enough to block high energy implanted ions from reaching the island. The photoresist can also pattern oversized openings to expose the emitter such that edges of the base poly stack are exposed around the perimeter of the emitter openings. An implant can then form the collector. Still further, the collector of the double poly transistor architecture can be formed after the base poly etch and before photoresist removal using an ion implantation. In this case, the field oxide should be thick enough to block the collector implant in unwanted areas.

An exemplary method of forming a double poly transistor **500** is shown for example in FIGS. **5A-I**. While FIGS. **5A-I** depict forming a PNP bipolar transistor, it is to be understood that an NPN bipolar transistor can be similarly formed by inverting the doping scheme. Turning to FIG. **5A**, integrated circuit **500** includes a P+ buried layer **502** and an N-type epitaxial layer **504** (also called a device layer) formed on the P+ buried layer **502**. The N-type epitaxial layer **504** forms the N-type collector columns of the resulting bipolar transistor. A P+ sinker implant **505** can also be formed by implanting P-type ions into the N-type epitaxial layer **504**. According to various embodiments, the P+ sinker implant can be boron or the like, and can be implanted with an energy from about 30 KeV to about 70 KeV and a dose from about $8E14$ ions/cm² to about $5E15$ ions/cm². In still further embodiments, the P+ sinker implant can be implanted with an energy of about 50 KeV and a dose of about $2E15$ ion/cm².

In FIG. **5B**, a field oxide **508** is formed and the P+ sinker **505** implant is diffused into the epitaxial layer **504** so as to form P+ sinker **506** that contacts the buried layer **502**. The field oxide **508** is formed so as to expose the P+ sinker **506** and a portion **510** of the epitaxial layer **504** that will form the device region. According to various embodiments, the field oxide **508** can be a local oxidation oxide, such as LOCOS, or

a shallow trench isolation oxide (STI). It will be understood, however, that other field oxide techniques are also contemplated.

FIG. **5C** shows a patterned first poly that acts as a base contact **512** where the base contact **512** is patterned using a patterned oxide **514** and a patterned photoresist **516**. The base contact **512** can be patterned to expose the epitaxial layer **504** through a hole **518** (also called an opening). P-type ions can be implanted into the epitaxial layer **504** through the hole **518**. According to various embodiments, the P-type ions can be implanted with an energy of 1 MeV and dose of $1.4 E12$ cm⁻²; energy of 750 KeV and dose of $1.4 E12$ cm⁻²; energy of 500 KeV and dose of $1.4 E12$ cm⁻²; energy of 300 keV and dose of $1.0 E12$ cm⁻²; energy of 140 KeV and dose of $1.2 E12$ cm⁻²; and energy of 30 KeV and dose of $6.2 E11$ cm⁻². The patterned photoresist **516** can be removed and the device **500** can be heated to diffuse the implanted P-type ions so as to form a column **520** in the epitaxial layer **504**, as shown in FIG. **5D**. Thus, the column **520** can be a region in the epitaxial layer **504** (also called the collector) that is doped to a net P-type conductivity. Moreover, the column **520** can span the thickness of the epitaxial layer **504** so as to contact the buried layer **502**.

As shown in FIG. **5E** an N-type intrinsic base **522** can be formed by implanting N-type ions using the base contact **512** and the patterned oxide **514** as a mask. Subsequently, the intrinsic base implant can be annealed so as to form the intrinsic base **522** that is contacted by the base contact **512**. The intrinsic base **522** can be thus be formed in a surface portion of the epitaxial layer **504**.

FIG. **5F** shows the device **500** after spacers **524** have been formed on the sidewalls of the hole **518**. Spacers **526** can also be formed on the sides of the base contact **512** and patterned oxide **514**. Spacers **524** and **526** can be formed by etching an insulating layer that has been deposited over the device **500**. According to various embodiments, the spacers can comprise an oxide, a nitride, or an oxinitride, or combinations thereof. For example, the spacers can comprise silicon oxide. Alternatively, the spacers can comprise a thin layer of silicon oxide (such as \leq about 100 Å) contacting the intrinsic base **522** with a layer of nitride disposed over the thin silicon oxide.

Subsequently, a layer of conducting material, such as polysilicon can be deposited over the device **500**. The conducting material can then be patterned to form a second poly that acts as an emitter contact **528** and which is disposed between the sidewall spacers **524**, as shown in FIG. **5G**. Moreover, the conducting material can be patterned to form a collector contact **530** over the P+ sinker **506**. According to various embodiments, an emitter **532** can be formed in a portion of the epitaxial layer **504** exposed by the hole **518** under the emitter contact. For example, the emitter **532** can be formed in the portion of the epitaxial layer **504** exposed between the spacers **526**. Thus, the emitter **532** contacts the epitaxial layer **504**. According to some embodiments, the emitter **532** can be formed by diffusing dopants into the intrinsic base **522** from the conducting material that forms the emitter contact **528**. While in other embodiments, the emitter **532** can be formed by ion implanting dopants into the intrinsic base **522**. Thus, the emitter **532** can be formed to be self aligned over the collector column **520**.

In FIG. **5H** an interlevel dielectric (ILD) **532** can be deposited and patterned to form windows that expose portions of the base contact **512**, emitter contact **528**, and collector contact **530**. The ILD can be an oxide. As shown in FIG. **5I**, a metal layer can be deposited over the ILD **532** and patterned so as to form base contact metal **534**, emitter contact metal **536**, and collector contact metal **538** through the patterned

windows. According to various embodiments, the metal layer can comprise aluminum, titanium, or other contact metals as will be known to one of ordinary skill in the art.

In the case of the single poly transistor architecture, the opening through the base poly can be used to define the emitter area and the super junction column self aligned there-
under.

FIGS. 6A-I depict a method of forming an integrated circuit having a super junction structure in a single poly PNP bipolar transistor **600**. While FIGS. 6A-6I depict forming a PNP bipolar transistor, it is to be understood that an NPN bipolar transistor can be similarly formed by inverting the doping scheme. Turning to FIG. 6A, transistor **600** includes a P+ buried layer **602** and an N-type epitaxial layer **604** (also called a device layer) formed on the P+ buried layer **602**. Portions of the N-type epitaxial layer **604** form N-type collector columns of the resulting bipolar transistor. A P+ sinker implant **605** can also be formed by implanting P-type ions into the N-type epitaxial layer **604**. According to various embodiments, boron (or another P-type dopant) can be implanted with an energy from about 30 KeV to about 100 KeV with a dose from about $8E14$ ions/cm² to about $4E15$ ion/cm². In still further embodiments, boron (or another P-type dopant) can be implanted with an energy of about 50 KeV and a dose of about $2E15$ ions/cm².

In FIG. 6B, an insulator, such as a field oxide **608** is grown and the P+ sinker **605** implant is diffused into the epitaxial layer **604** so as to form P+ sinker **606** that contacts the buried layer **602**. According to various embodiments, the field oxide **608** can be also be a local oxidation oxide, such as LOCOS, or a shallow trench isolation oxide (STI). It will be understood, however, that other field oxide techniques are also contemplated.

In FIG. 6C the field oxide **608** is patterned to form a hole (also called an opening) so as to expose a portion **610** of the epitaxial layer **604** that will form the device region. FIG. 6C also shows the result of an N-type base implantation **611** into the exposed portion of epitaxial layer **604**. According to various embodiments, phosphorous (or another N-type dopant) can be implanted with an energy from about 30 KeV to about 100 KeV with a dose from about $2E13$ ions/cm² to about $5E14$ ion/cm². In still further embodiments, phosphorous (or another N-type dopant) can be implanted with an energy of about 50 KeV and a dose of about $5E13$ ions/cm² to about $2E14$ ions/cm².

In FIG. 6D, N-type base implantation **611** has been diffused to form an N-type base **612**. A base oxide **614** can also be grown over the N-type base **612**. As shown in FIG. 6E, an opening **616** through the base oxide **614** is formed using a patterned photoresist **618** so as to expose an area of the device layer. In FIG. 6F a P-type collector column **620** can be formed with the mask used to form the opening **616**. P-type ions can be implanted through the opening so that the collector column **620** is self aligned to the opening **616**. According to various embodiments, the P-type implants can be made boron (or another P-type dopant) with an energy of 1 MeV and dose of $1.4 E12$ cm.sup.-2; energy of 750 KeV and dose of $1.4 E12$ cm.sup.-2; energy of 500 KeV and dose of $1.4 E12$ cm.sup.-2; energy of 300 KeV and dose of $1.0 E12$ cm.sup.-2; energy of 140 KeV and dose of $1.2 E12$ cm.sup.-2; and energy of 30 KeV and dose of $6.2 E11$ cm.sup.-2. Moreover, the collector column **620** can span the thickness of the epitaxial layer **604** so as to contact the buried layer **602**.

A heavily doped emitter poly **622** can then be formed over the opening **616** so that the emitter area is defined by the opening **616** that defines the area where the emitter poly contacts the base **612**, as shown in FIG. 6G. At this point in the

process the collector column **620** can be properly diffused and activated after the photoresist **618** has been removed. According to various embodiments, the collector can be diffused before depositing the emitter poly. FIG. 6H shows a patterned hole **622** that allows dopants to be diffused into the base so as to form a base contact region **624**. In FIG. 6H, dopants from the heavily doped emitter poly **622** can be diffused to form an emitter **626** positioned, and self-aligned above the collector column **620**.

FIG. 6I shows a patterned ILD **632** having trenches that expose the base contact region **624**. The ILD can be deposited over the emitter poly **622**. As shown in FIG. 6I, a metal layer can be deposited over the ILD **632** and patterned so as to form base contact metal **634**, emitter contact metal **636**, and collector contact metal **638** through the patterned trenches. According to various embodiments, the metal layer can comprise aluminum, titanium, or other contact metals as will be known to one of ordinary skill in the art.

According to various embodiments, the absolute value of VCB can be less than the absolute value of BV_{CEO} when the portion of the column under the emitter totally depletes. This can be true for a PNP device where VCB and BV_{CEO} are both negative as well as the case for an NPN device where they both are positive. According to various embodiments of an NPN device, the region that depletes can be the column in the epitaxial layer, in which the collector is formed, under the emitter. Moreover, according to various embodiments, the column under the emitter can be the column that depletes regardless of how the device is formed.

The collector-base capacitance of the devices made with the depletable columns will differ from that of the conventional device. For example, it may initially be higher. This can be a result of the higher doping of the columns and increased junction area. The collector-base capacitance, however, will drop abruptly when the columns totally deplete.

According to various embodiments, devices made with depletable columns under the emitter, such as those described herein, can have BV_{CEO} of at least 69 V and an HFE of about 83 for an NPN device, and at least 82 V and an HFE of about 101, for a PNP device. HFE is understood to be a measure of current gain and can be described, generally, as the ratio of collector current to base current at a specified collector to emitter voltage. This is in contrast to a BV_{CEO} of 37 V for a conventional NPN device and 40 V for a conventional PNP device made with the same doped layers but without the depletable columns under the emitters. Moreover, these new devices can have lower R_{es} , such as 1.5 k Ω , than devices made with similar emitter areas.

Exemplary collector resistances achieved using the super junction structures described herein (shown with a solid line) in comparison to collector resistances conventional collector structures (shown with a solid line with slashes) are shown in FIGS. 7 and 8. In these figures, the NPN collector doping is about $2E15$ atoms cm⁻³, the columns length is about 5 microns and the column thickness is about 8 microns. The PNP collector doping is about $4E15$ atoms cm⁻³, the column length is about 4 microns and the column thickness is about 4 microns.

According to various embodiments, the devices of the present invention comprise a depletable collector column under the emitter and the devices can achieve a BV_{CEO} about twice that of conventional devices. Moreover, the NPN devices of the present invention comprising a depletable collector column under the emitter can achieve an R_{cs} about three times lower than that of conventional devices. Still further, the PNP devices of the present invention comprising

a depletable collector column under the emitter can achieve an Rcs about 30% less than conventional devices.

In a still further exemplary embodiment, a PNP bipolar transistor comprising a super junction structure described herein can have a breakdown of about 30 V. In this example, the column under the emitter can be about 2.3 μm long before the base is formed. The columns of the super junction can be formed using, for example, six boron implants, with the following parameters: energy of 1 MeV and dose of $1.4 \text{ E}12 \text{ cm}^{-2}$; energy of 750 KeV and dose of $1.4 \text{ E}12 \text{ cm}^{-2}$; energy of 500 KeV and dose of $1.4 \text{ E}12 \text{ cm}^{-2}$; energy of 300 KeV and dose of $1.0 \text{ E}12 \text{ cm}^{-2}$; energy of 140 KeV and dose of $1.2 \text{ E}12 \text{ cm}^{-2}$; and energy of 30 KeV and dose of $6.2 \text{ E}11 \text{ cm}^{-2}$. Moreover in this exemplary embodiment, the ions can be implanted into an N-type epitaxial layer about 3 μm thick doped to a concentration of about $5.0 \text{ E}15 \text{ cm}^{-3}$. The epitaxial layer can be formed on a buried layer doped to a concentration of about $2.0 \text{ E}17 \text{ cm}^{-3}$. The dopant of the buried layer can be, for example boron. Still further, the super junction column implants can be made through a 1.0 μm wide mask opening and the dopants can be diffused, for example at 1200° C. for about 15 min. An exemplary dopant profile for before the diffusion is shown in FIG. 9 and an exemplary dopant profile after the diffusion is shown in FIGS. 10A-C.

While the invention has been illustrated with respect to one or more implementations, alterations and/or modifications can be made to the illustrated examples without departing from the spirit and scope of the appended claims. In addition, while a particular feature of the invention may have been disclosed with respect to only one of several implementations, such features may be combined with one or more other features of the other implementations as may be desired and advantageous for any given or particular function. Furthermore, to the extent that the terms “including”, “includes”, “having”, “has”, “with”, or variants thereof are used in either the detailed description and the claims, such terms are intended to be inclusive in a manner similar to the term “comprising.”

Other embodiments of the invention will be apparent to those skilled in the art from consideration of the specification and practice of the invention disclosed herein. It is intended that the specification and examples be considered as exemplary only, with a true scope and spirit of the invention being indicated by the following claims.

Other embodiments of the invention will be apparent to those skilled in the art from consideration of the specification and practice of the invention disclosed herein. It is intended that the specification and examples be considered as exemplary only, with a true scope and spirit of the invention being indicated by the following claims.

The invention claimed is:

[1. An integrated circuit comprising a bipolar transistor comprising:

a substrate;

a collector comprising a plurality of alternating doped regions, wherein the plurality of alternating doped regions alternate in a lateral direction from a net first conductivity to a net second conductivity;

a collector contact in electrical contact with the collector;

a heavily doped buried layer below the collector;

a base in electrical contact with a base contact, wherein the base is doped to the net second conductivity type and wherein the base spans a portion of the plurality of alternating doped regions; and

an emitter disposed totally within the base, the emitter doped to the net first conductivity, wherein a portion of

the alternating doped region under the emitter is doped to a concentration of less than about $3 \times 10^{12} \text{ cm}^{-2}$ in the lateral direction.]

[2. The integrated circuit comprising a bipolar transistor according to claim 1, wherein the portion of the alternating doped region under the emitter is doped to a concentration of less than about $2 \times 10^{12} \text{ cm}^{-2}$ in a lateral direction.]

[3. The integrated circuit comprising a bipolar transistor according to claim 1, wherein a portion of the alternating doped regions disposed beneath the emitter is doped to a net first conductivity type.]

[4. The integrated circuit comprising a bipolar transistor according to claim 3, wherein a width of the doped region disposed beneath the emitter is substantially the same as a width of the emitter.]

[5. The integrated circuit comprising a bipolar transistor according to claim 3, wherein the doped region disposed beneath the emitter extends from the base to the more heavily doped buried layer.]

[6. The integrated circuit comprising a bipolar transistor according to claim 5, wherein the length, as defined from the base to the buried layer, of the alternating doped region under the emitter is defined by BV_{CEO}/E_{crit} .]

[7. The integrated circuit comprising a bipolar transistor according to claim 1 further comprising:
an electrical sinker in electrical contact with the collector contact and in electrical contact with the more heavily doped buried layer.]

[8. The integrated circuit comprising a bipolar transistor according to claim 3 farther comprising:
at least one doped second region disposed adjacent to the doped region disposed under the emitter, wherein the at least one doped second region is doped to a net second conductivity type.]

[9. The integrated circuit comprising a bipolar transistor according to claim 8, wherein the doped region disposed beneath the emitter depletes at a reverse bias collector base voltage of magnitude less than an absolute value of BV_{CEO} .]

[10. The integrated circuit comprising a bipolar transistor according to claim 8, wherein the doped second regions disposed adjacent to the doped region disposed beneath the emitter depletes under a reverse bias collector voltage less than BV_{CEO} .]

[11. The integrated circuit comprising a bipolar transistor according to claim 1, further comprising a second bipolar transistor, wherein the bipolar transistor has a breakdown voltage greater than the second bipolar transistor.]

[12. The integrated circuit comprising a bipolar transistor according to claim 8, wherein the doped second regions disposed adjacent to the doped region disposed beneath the emitter do not totally deplete at a magnitude of collector base voltage less than the magnitude of the BV_{CEO} breakdown voltage.]

[13. The integrated circuit comprising a bipolar transistor according to claim 1, wherein an integral across the width of the doped region under the emitter has a value of less than about $3 \text{ E}12 \text{ ions/cm}^2$.]

[14. The integrated circuit comprising a bipolar transistor according to claim 1, wherein the portion of doped region under the emitter is self aligned to the emitter.]

[15. An integrated circuit comprising a bipolar transistor comprising:

a substrate;

a base formed in the substrate;

a collector comprising a doped first region doped to a net first conductivity disposed under the base, to cover the base and doped second regions doped to a net second

15

conductivity disposed on opposite sides of the doped first region; wherein the base is doped to the net second conductivity type;

a collector contact in electrical contact with the collector; a more heavily doped layer buried below the doped first region and the doped second regions; and

an emitter doped to the net first conductivity disposed within the base, wherein the doped region disposed beneath the emitter depletes at a reverse bias collector base voltage of magnitude less than an absolute value of BV_{CEO} .]

[16. The integrated circuit comprising a bipolar transistor according to claim 15, wherein the doped second regions disposed adjacent to the doped first region do not totally deplete under reverse bias of the collector to base junction.]

[17. The integrated circuit comprising a bipolar transistor according to claim 15, wherein the bipolar transistor is an NPN bipolar transistor comprising a BV_{CEO} of at least 69 Volts.]

[18. The integrated circuit comprising a bipolar transistor according to claim 15, wherein the bipolar transistor is a PNP bipolar transistor comprising a BV_{CEO} of at least 82 Volts.]

[19. The integrated circuit comprising a bipolar transistor according to claim 15, wherein the bipolar transistor is an NPN bipolar transistor, and wherein the collector is doped with at least about 2×10^{15} atoms/cm³.]

[20. The integrated circuit comprising a bipolar transistor according to claim 15, wherein the bipolar transistor is an NPN bipolar transistor, and wherein first doped region has a length of about 4 μ m to about 6 μ m, and further wherein the first doped region has a width of about 7 μ m to about 9 μ m.]

[21. The integrated circuit comprising a bipolar transistor according to claim 15, wherein the bipolar transistor is a PNP bipolar transistor, and wherein the collector is doped with at least about 4×10^{15} atoms/cm³.]

[22. The integrated circuit comprising a bipolar transistor according to claim 15, wherein the bipolar transistor is a PNP bipolar transistor, and wherein first doped region has a length of about 3 μ m to about 5 μ m, and further wherein the first doped region has a width of about 3 μ m to about 5 μ m.]

[23. The integrated circuit comprising a bipolar transistor according to claim 18, further comprising:

a PNP bipolar transistor comprising a BV_{CEO} of at least 82 Volts.]

[24. The integrated circuit comprising a bipolar transistor according to claim 15, wherein the doped region disposed beneath the emitter is self aligned to the emitter.]

25. A method of making a bipolar transistor, the method comprising:

forming a device layer of a first type conductivity over a substrate;

forming a patterned layer over the device layer, wherein the patterned layer comprises an opening that exposes a portion of the device layer;

providing dopants of a second conductivity type to the exposed portion of the device layer to form a column of second conductivity type dopants in the device layer;

providing dopants of the first conductivity type to the exposed portion of the device layer to form an intrinsic base in the device layer;

forming an emitter that contacts a portion of the exposed device layer; and

forming an emitter contact over the emitter.

26. The method of claim 25, wherein forming the device layer of the first type conductivity over the substrate comprises forming the device layer of a first type conductivity over a heavily doped substrate.

16

27. A method of making a bipolar transistor, the method comprising:

forming a device layer over a substrate;

forming a patterned insulator over the device layer, wherein the patterned insulator comprises a first opening that exposes a first portion of the device layer;

providing dopants of a conductivity type to the exposed first portion of the device layer to form a base in the device layer;

forming a patterned base insulator over the exposed first portion of the device layer, wherein the patterned base insulator comprises a second opening that exposes an area of the first portion of the device layer;

providing dopants of a second conductivity type to the exposed area of the first portion of the device layer to form a column of second conductivity type dopants in the device layer; and

forming an emitter that contacts a portion of the exposed area of the first portion of the device layer.

28. The method of claim 27, wherein the conductivity type is a first conductivity type wherein forming the device layer over the substrate comprises forming the device layer having a second conductivity type.

29. The method of claim 27, wherein forming the device layer over the substrate comprises forming the device layer over a heavily doped substrate.

30. A method of making a bipolar transistor, the method comprising:

forming a device layer having a first conductivity type over a substrate;

forming first heavily doped buried regions of the first conductivity type in first portions of the device layer;

forming second heavily doped buried regions of a second conductivity type in second portions of the device layer;

forming an epitaxial layer having the first conductivity type over the device layer;

forming two regions of the second conductivity type over at least one of the first heavily doped buried regions of the first conductivity type; and

forming one region of the second conductivity type over at least one of the second heavily doped buried regions of the second conductivity type.

31. The method of claim 30, wherein forming the epitaxial layer having the first conductivity type over the device layer comprises forming a first epitaxial layer having the first conductivity type over the device layer, the method further comprising:

forming a second epitaxial layer having the first conductivity type over the first epitaxial layer.

32. The method of claim 30, further comprising: masking the epitaxial layer with a mask layer to provide openings to allow ions of the second conductivity type to be implanted in the epitaxial layer.

33. The method of claim 30, further comprising: heating the formed layers to diffuse and form columns of the second conductivity type in the epitaxial layer.

34. The method of claim 33, wherein the first conductivity type is N-type and the second conductivity type is P-type, wherein heating the formed layers comprises:

diffusing and forming at least one P-type column in an NPN collector over at least one of the first heavily doped buried regions of the first conductivity type in the first portions of the device layer; and

diffusing and forming at least one P-type column in a PNP collector over at least one of the second heavily doped buried regions of a second conductivity type in second portions of the device layer.

35. The method of claim 33, wherein the first conductivity type is P-type and the second conductivity type is N-type, wherein heating the formed layers comprises:

diffusing and forming at least one N-type column in a PNP collector over at last one of the first heavily doped buried regions of the first conductivity type in the first portions of the device layer; and

diffusing and forming at least one N-type column in an NPN collector over at last one of the second heavily doped buried regions of the second conductivity type in second portions of the device layer.

36. A method of making a bipolar transistor with a base, an emitter, and a collector, which are self aligned to each other, the method comprising:

forming a device layer having a first conductivity type on a buried layer doped with a second conductivity type;

forming an oxide layer over a base contact layer overlaying the device layer so as to expose a portion of the device layer that will form a device region;

patterning a base contact in the device region;

exposing the device layer through a hole in the base contact;

implanting and diffusing ions having the second conductivity type so as to form a column in a first region of the device layer;

forming a base by implanting ions having the first conductivity type using the base contact as a mask; and annealing the base implant so that the base is contacted by the base contact.

37. The method of claim 36, wherein forming a device layer having the first conductivity type comprises forming an epitaxial layer having the first conductivity type.

38. The method of claim 37, wherein diffusing the ions having the second conductivity type so as to form the column in the epitaxial layer comprises forming the column to span a thickness of the epitaxial layer so as to contact the buried layer.

39. The method of claim 36, further comprising:

implanting ions having the second conductivity type into a second region of the device layer having the first conductivity type.

40. The method of claim 39, further comprising:

patterning a collector contact over the ions having the second conductivity type in the second region of the device layer while patterning the layer of conducting material to form the emitter contact.

41. The method of claim 36, further comprising:

forming spacers on sidewalls of the hole in the base contact;

depositing a layer of conducting material over the device region; and

patterning the layer of conducting material to form an emitter contact disposed between the sidewall spacers, wherein the self-aligned emitter contacts the device layer.

42. The method of claim 36, wherein forming the device layer having the first conductivity type on the buried layer having the doped second conductivity type comprises

forming the device layer having the first conductivity type on the buried layer heavily doped in the second conductivity type.

43. A method of making a bipolar transistor comprising: forming an epitaxial layer having a first conductivity type on a buried layer having a doped second conductivity type;

growing an insulator over the epitaxial layer and implanted ions;

diffusing the implanted ions into the epitaxial layer to form a sinker that contacts the buried layer;

patterning the insulator layer to expose a portion of the epitaxial layer that will form a device region;

forming a base of the first conductivity type in the exposed portion;

growing a base oxide over the base of the first conductivity type;

forming an opening through the base oxide using a patterned photoresist so as to expose an area of a device layer;

forming a collector column of the second conductivity type using the patterned photoresist;

diffusing and activating the collector column;

forming an emitter heavily doped with the second conductivity type in the base wherein an emitter area is defined in the opening; and

forming an emitter positioned above the collector column in a surface of the base.

44. The method of claim 43, further comprising implanting ions having the second conductivity type into a first region of the epitaxial layer having the first conductivity type;

growing an insulator over the device layer and the implanted ions; and

diffusing the implanted ions into the device layer to form a sinker that contacts the buried layer.

45. The method of claim 43, further comprising forming emitter poly heavily doped with the second conductivity type over the opening wherein the emitter area is defined in the opening where the emitter poly contacts the base.

46. The method of claim 43, wherein forming an emitter positioned above the collector column comprises forming the emitter self-aligned above the collector column.

47. The method of claim 43, further comprising

exposing a base contact region; and

depositing a metal layer to form base contact metal, emitter contact metal, and collector contact metal through patterned trenches, wherein the base, the emitter, and the collector column are self aligned.

48. The method of claim 43, wherein the collector column spans the thickness of the epitaxial layer so as to contact the buried layer.