

US00RE44105E

(19) **United States**
(12) **Reissued Patent**
Khan

(10) **Patent Number:** **US RE44,105 E**
(45) **Date of Reissued Patent:** **Mar. 26, 2013**

(54) **APPARATUS AND METHOD FOR FT
PRE-CODING OF DATA TO REDUCE PAPR IN
A MULTI-CARRIER WIRELESS NETWORK**

(75) Inventor: **Farooq Khan**, Allen, TX (US)

(73) Assignee: **Samsung Electronics Co., Ltd.**,
Suwon-si (KR)

(21) Appl. No.: **13/011,091**

(22) Filed: **Jan. 21, 2011**

Related U.S. Patent Documents

Reissue of:

(64) Patent No.: **7,787,546**
Issued: **Aug. 31, 2010**
Appl. No.: **11/374,928**
Filed: **Mar. 14, 2006**

U.S. Applications:

(60) Provisional application No. 60/668,797, filed on Apr. 6, 2005.

(51) **Int. Cl.**
H04L 27/06 (2006.01)

(52) **U.S. Cl.** **375/340; 375/349; 375/260; 375/267;**
375/261; 375/232; 455/103; 455/456.5; 455/456.6;
708/403; 708/405; 708/821

(58) **Field of Classification Search** **375/260,**
375/340, 232, 233, 261, 349, 267; 455/103,
455/456.5, 456.6; 708/403, 405, 821

See application file for complete search history.

(56) **References Cited**

U.S. PATENT DOCUMENTS

6,459,723	B1 *	10/2002	Kim et al.	375/146
7,340,256	B2 *	3/2008	Speight	455/450
7,817,605	B2 *	10/2010	Liu	370/337
7,929,407	B2 *	4/2011	Ma et al.	370/203
2002/0086708	A1 *	7/2002	Teo et al.	455/561
2003/0043764	A1 *	3/2003	Kim et al.	370/329
2003/0123383	A1 *	7/2003	Korobkov et al.	370/208
2004/0028148	A1 *	2/2004	Dowling	375/296
2004/0076239	A1 *	4/2004	Yu et al.	375/260
2004/0257980	A1 *	12/2004	Yeh et al.	370/210
2005/0286648	A1 *	12/2005	Feng et al.	375/260
2006/0203932	A1 *	9/2006	Palanki et al.	375/295
2006/0224651	A1 *	10/2006	Madhavapeddi et al.	708/404

* cited by examiner

Primary Examiner — Daniel Washburn
Assistant Examiner — Rahel Guarino

(57) **ABSTRACT**

A subscriber station for use in a wireless network capable of communicating according to a multi-carrier protocol, such as OFDM or OFDMA. The subscriber station comprises a size M Fourier Transform (FFT or DFT) block for receiving input symbols and generating M FT pre-coded outputs and a size N inverse Fourier Transform (IFFT or IDFT) block capable of receiving N inputs, where the N inputs include the M FT pre-coded outputs from the size M FT block. The size N IFT block generates N outputs to be transmitted to a base station of the wireless network. The input symbols comprise user data traffic to be transmitted to the base station. The size N IFT block also receives signaling and control information on at least some of N-M inputs. The FT pre-coding generates a time-domain signal that has a relatively lower peak-to-average power ratio (PAPR).

47 Claims, 12 Drawing Sheets

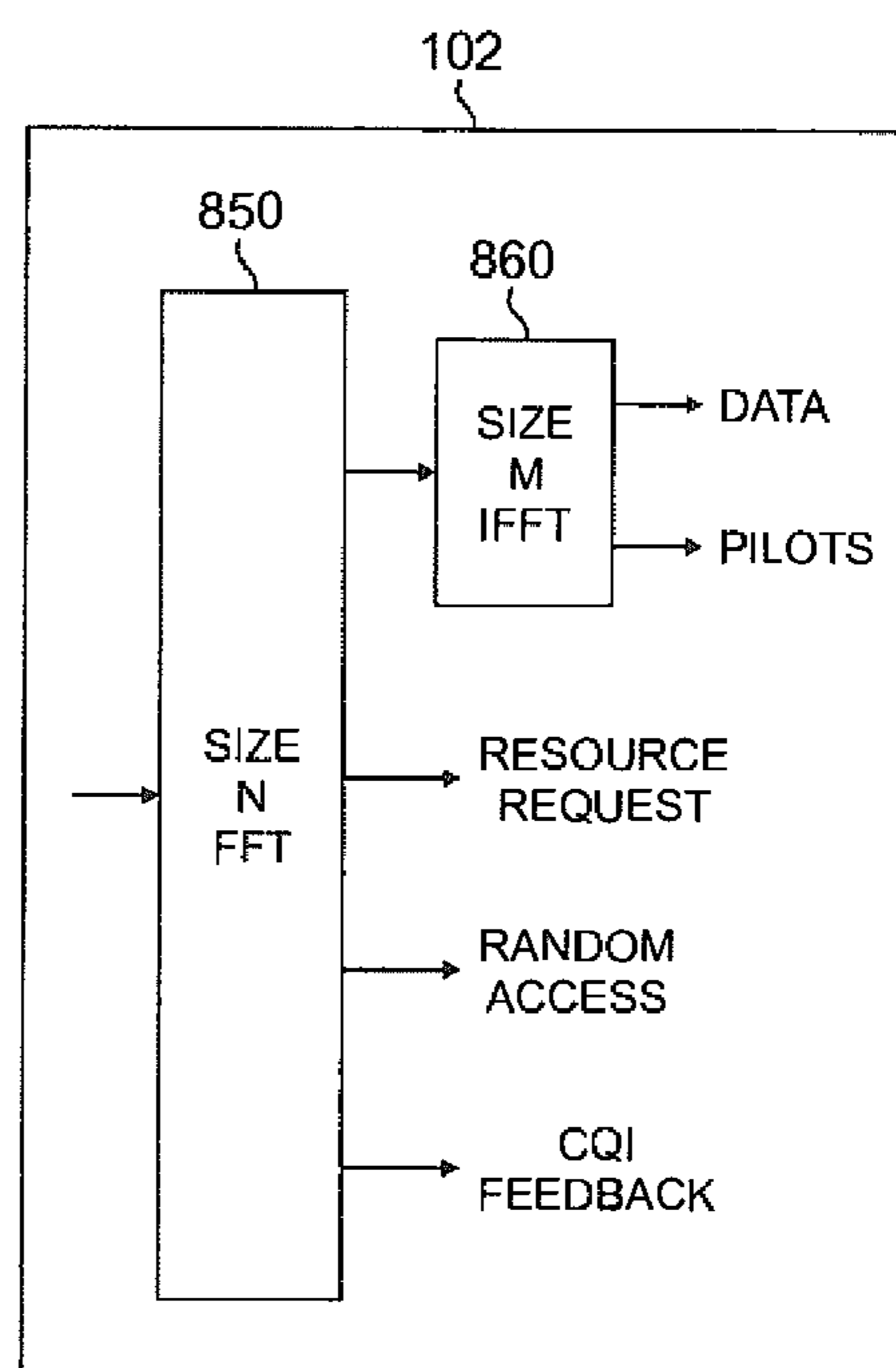
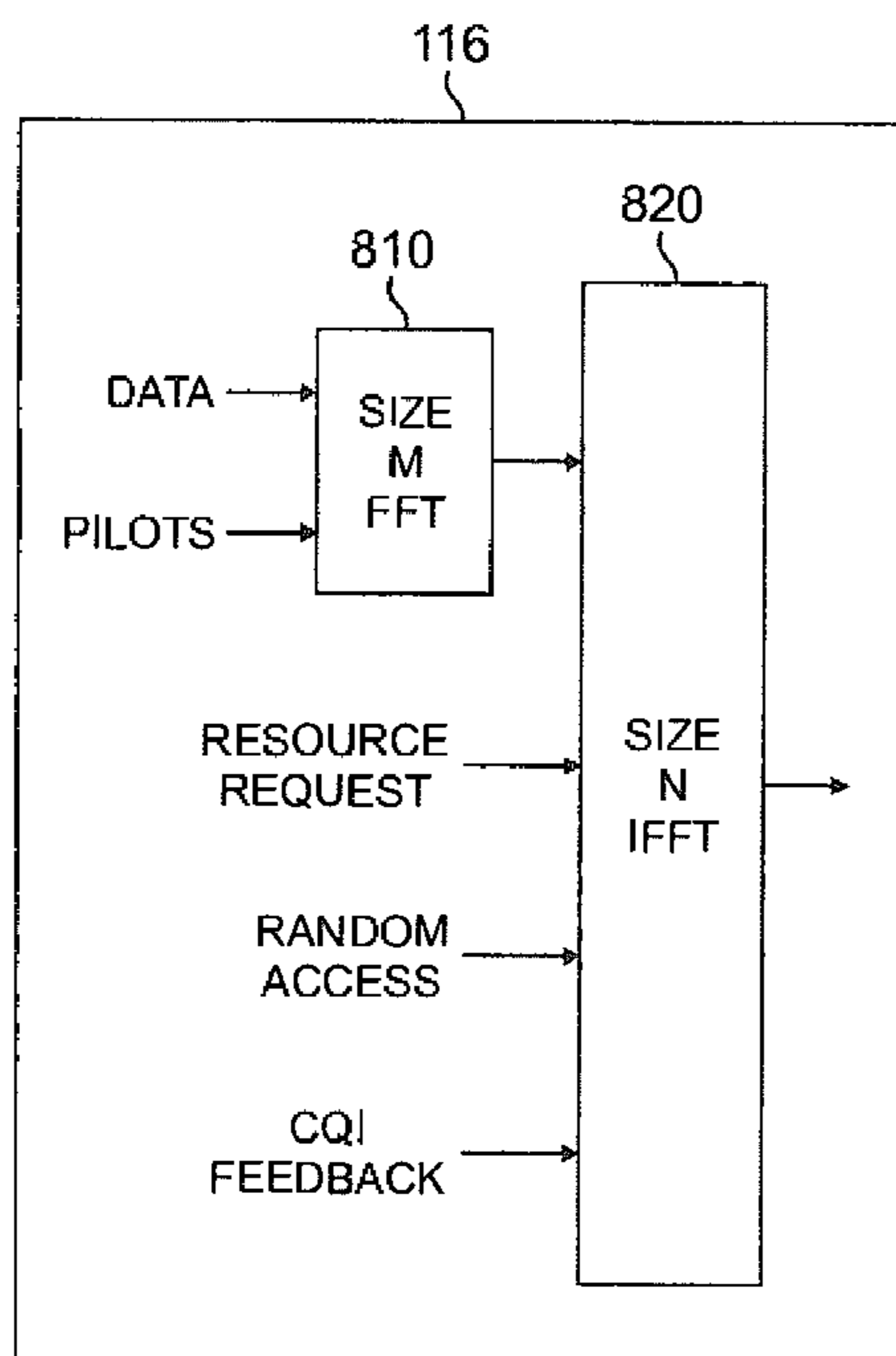

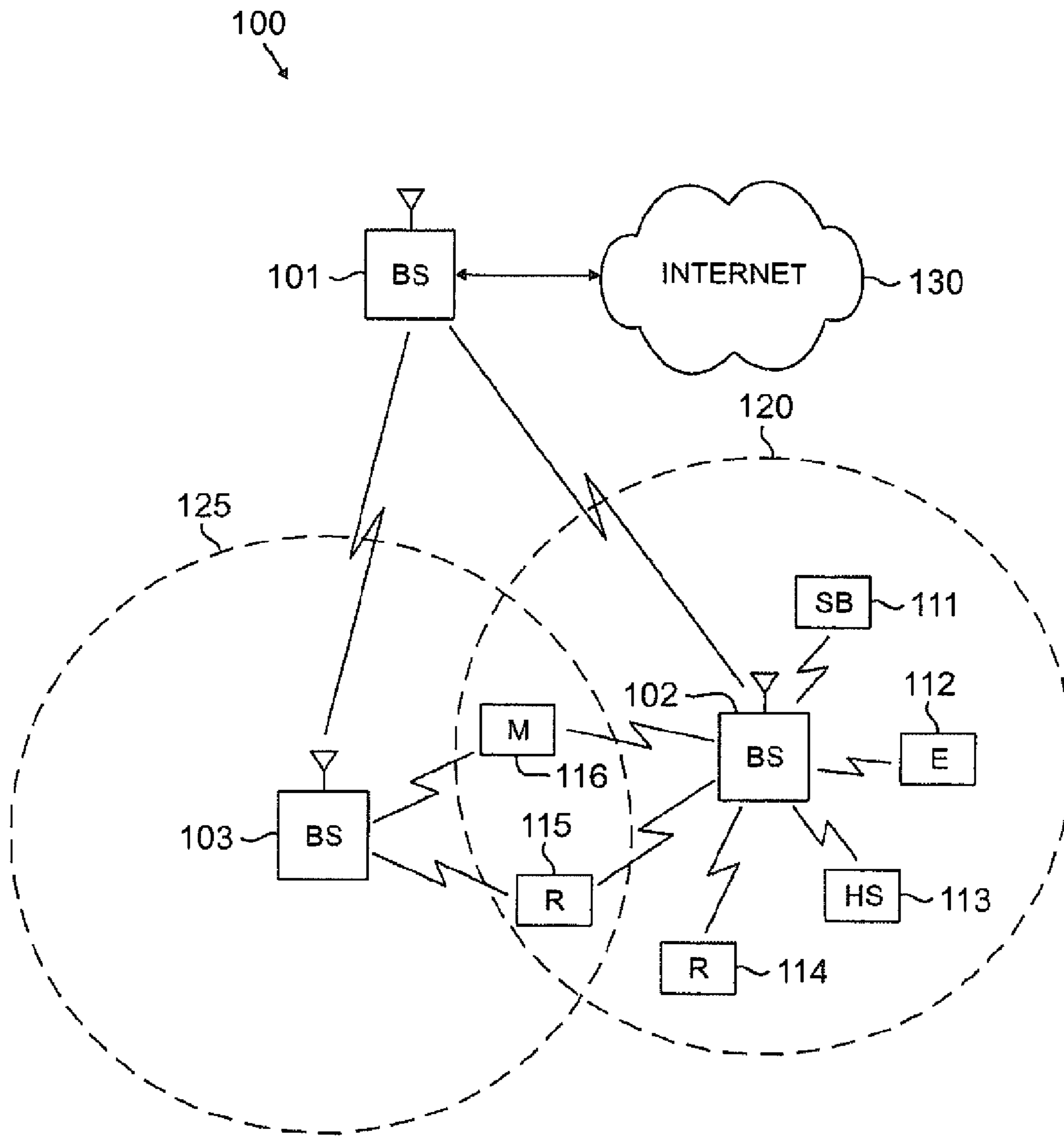

FIG. 1

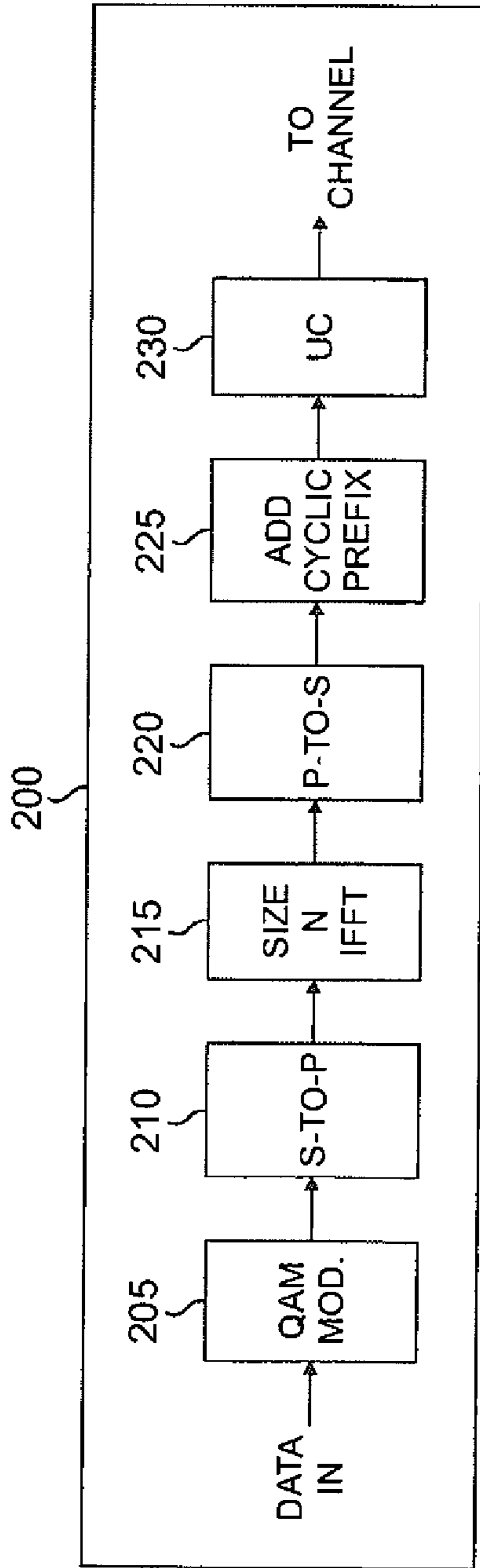

FIG. 2A

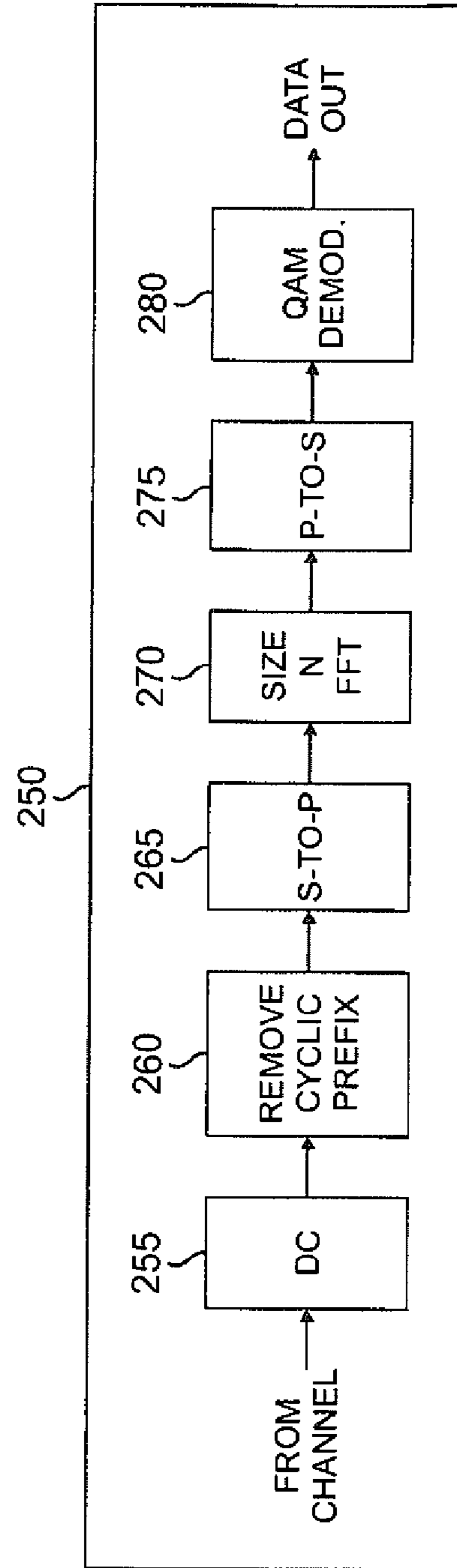

FIG. 2B

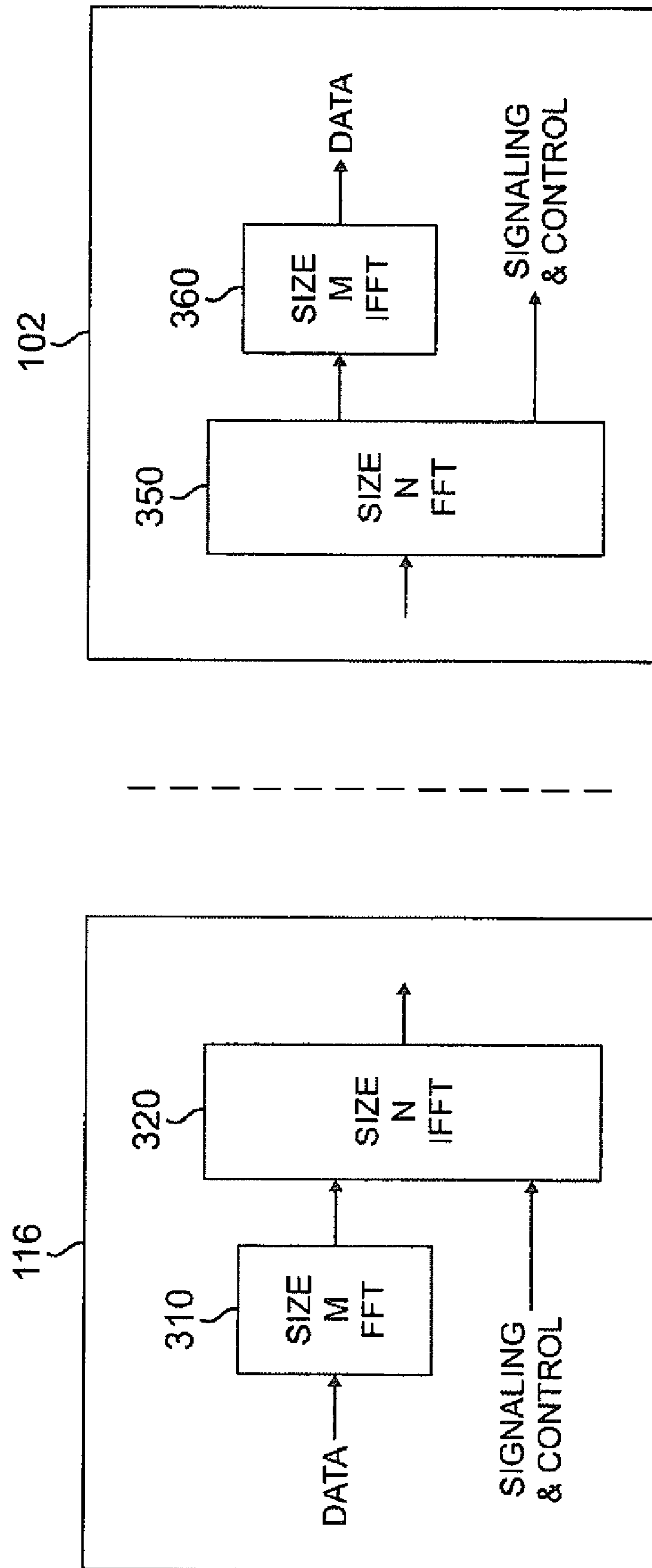

FIG. 3

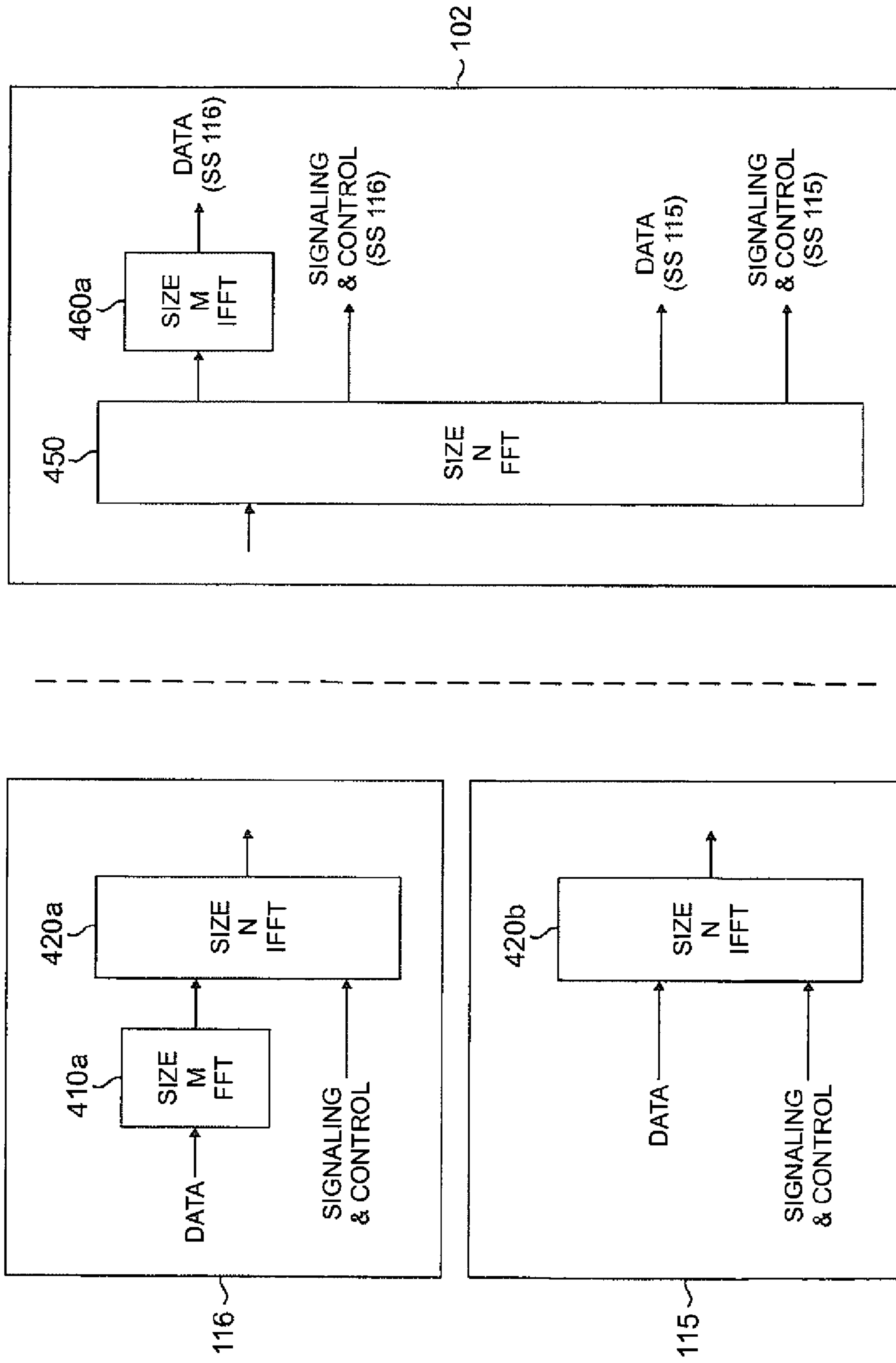

FIG. 4

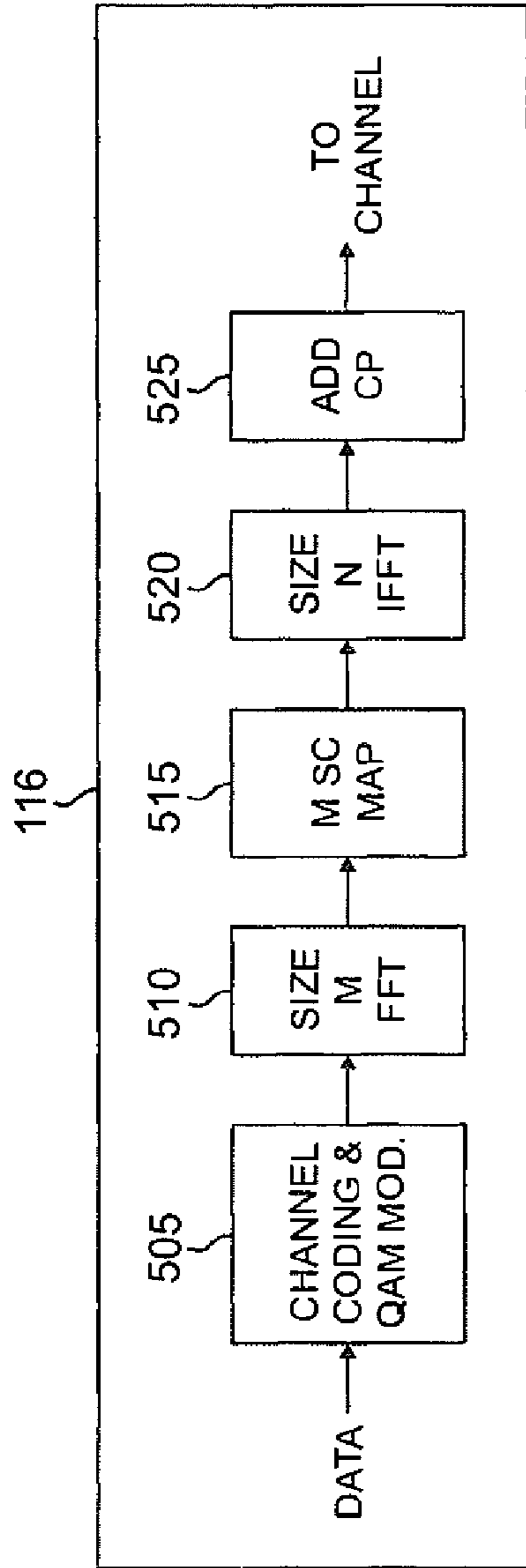

FIG. 5A

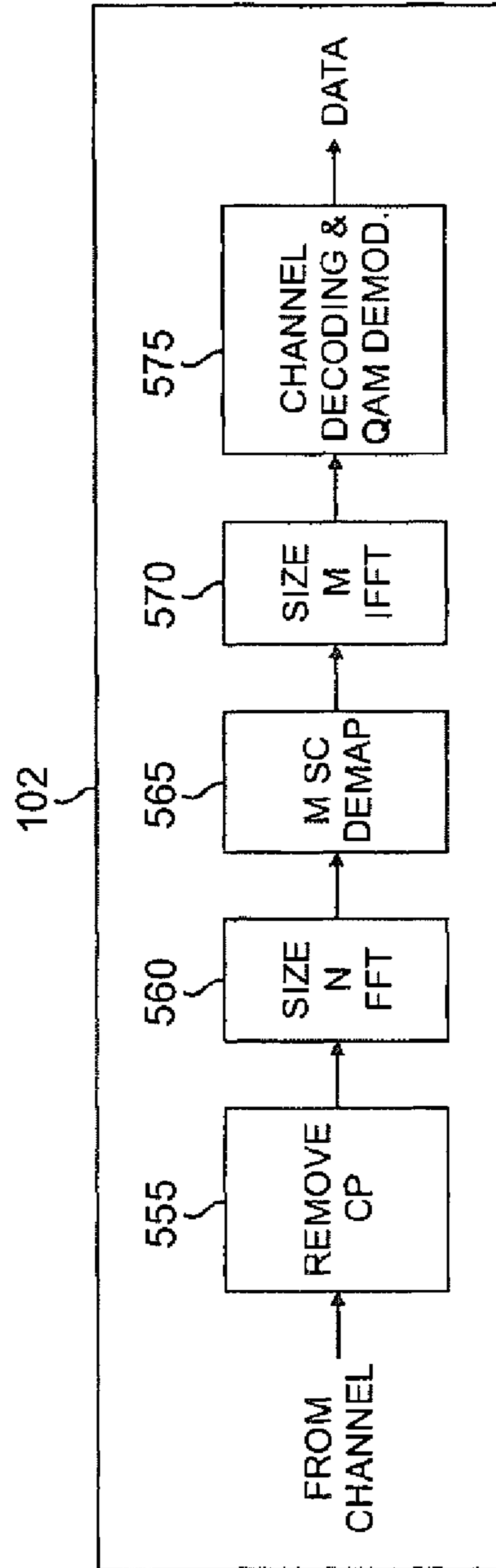

FIG. 5B

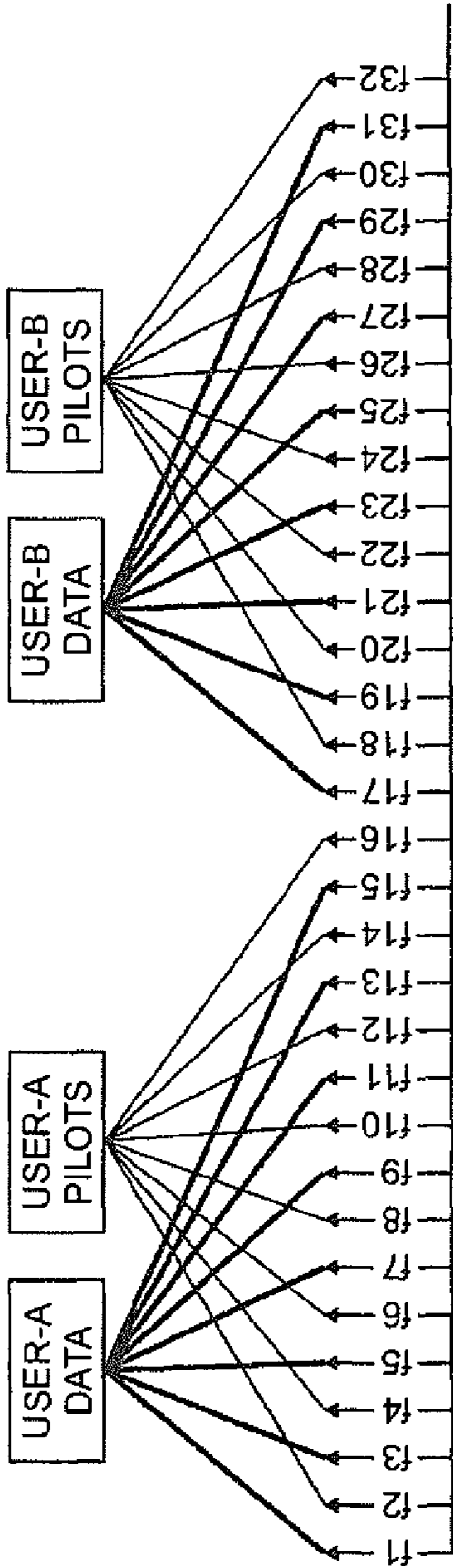

FIG. 6A

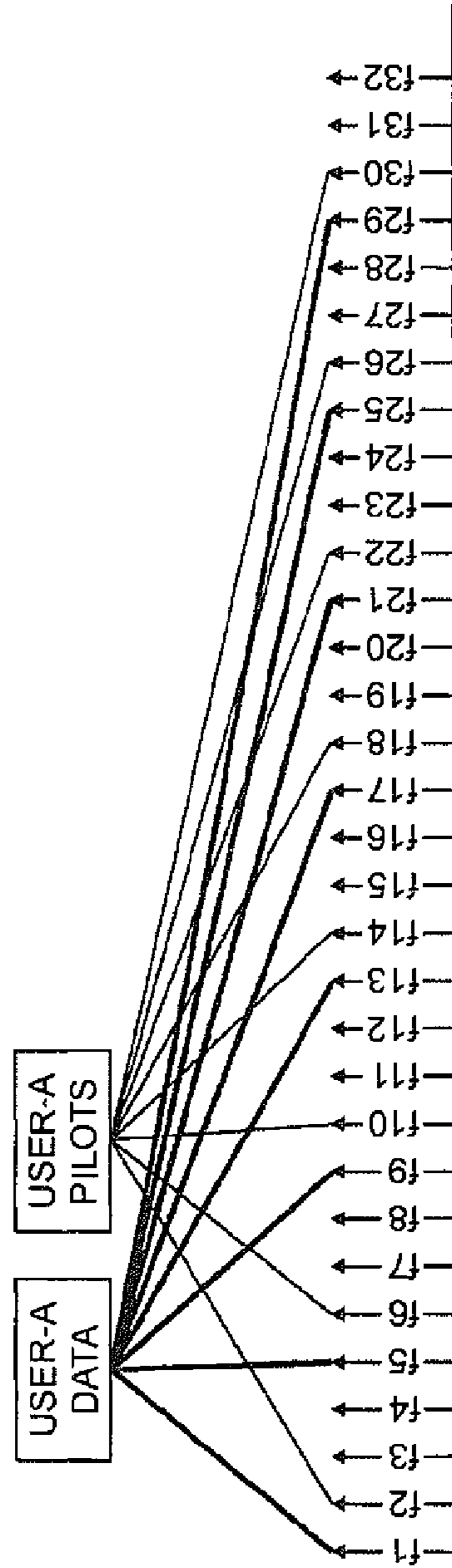

FIG. 6B

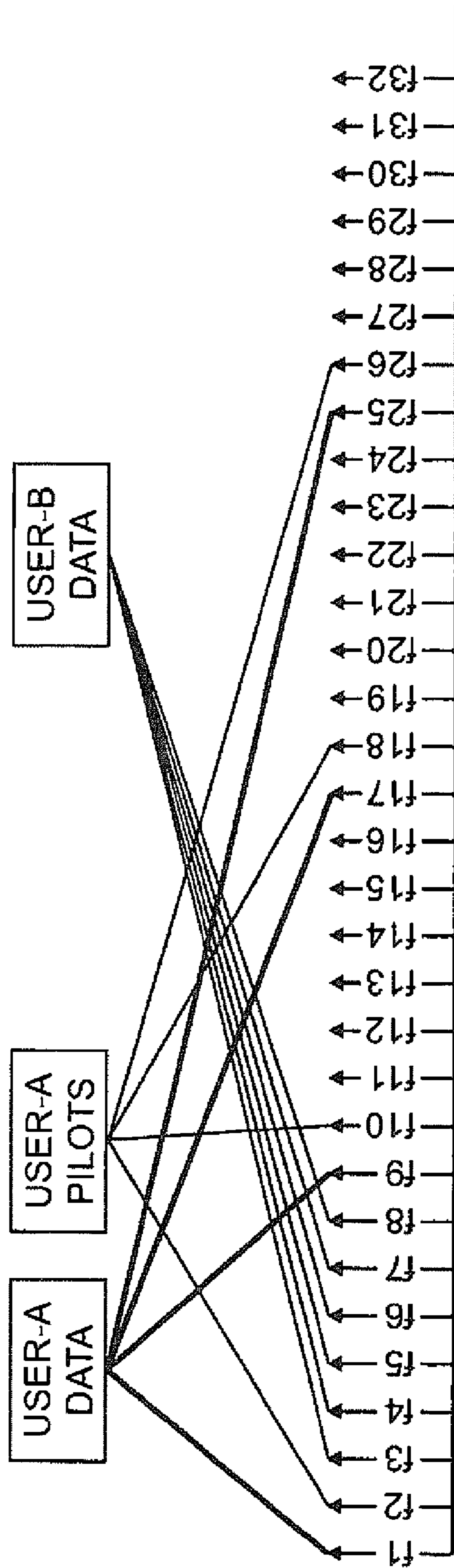

FIG. 6C

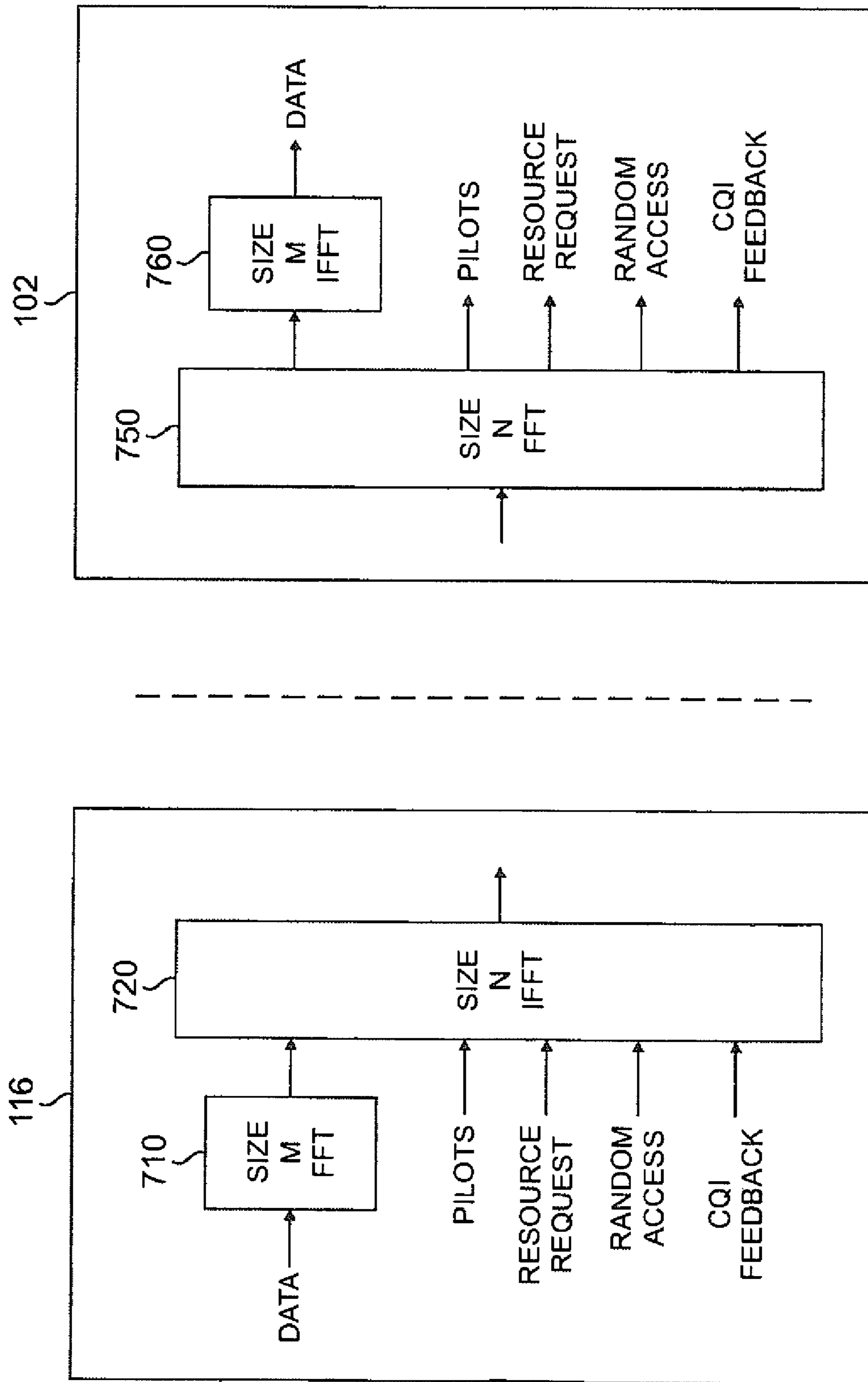

FIG. 7

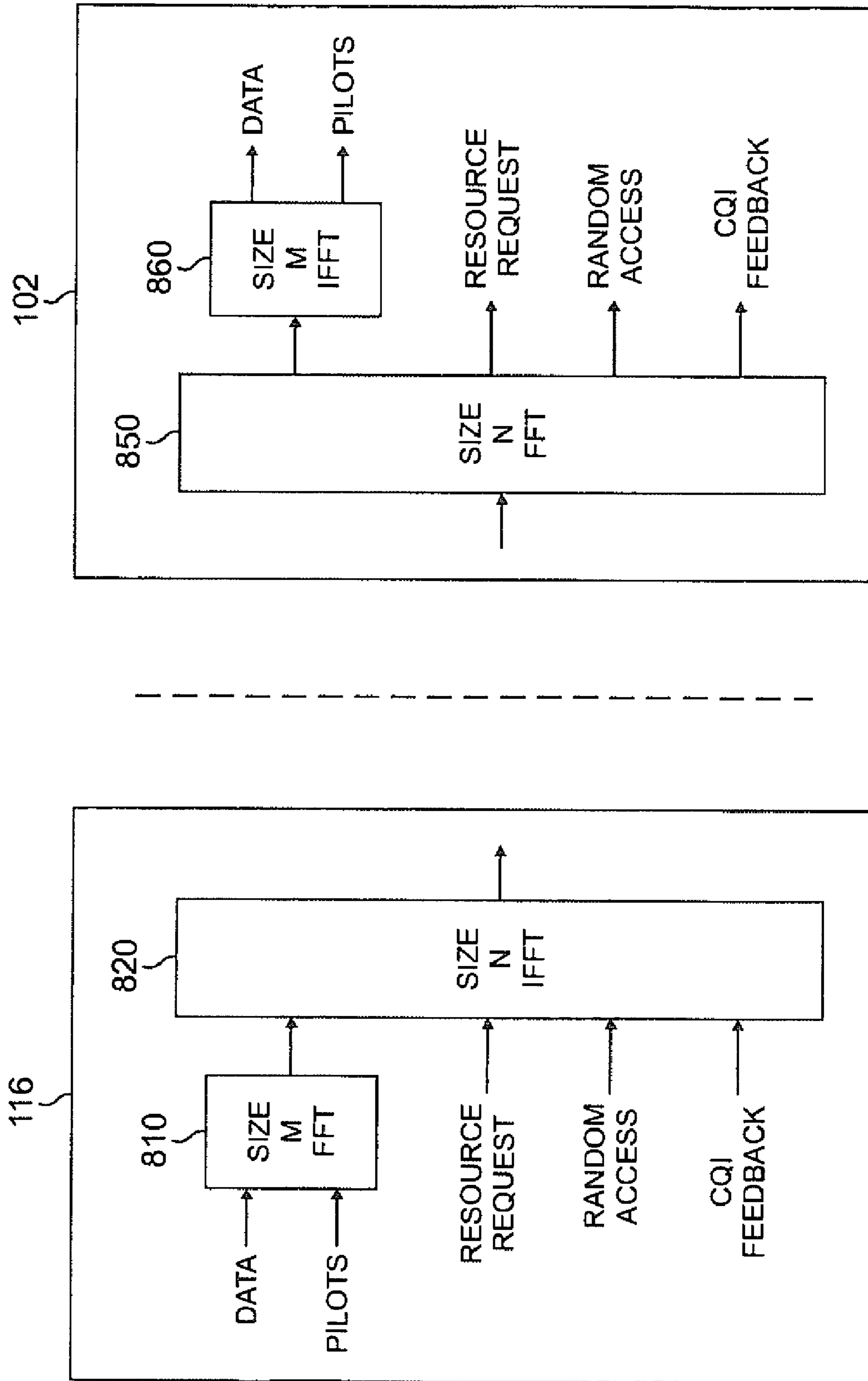

FIG. 8

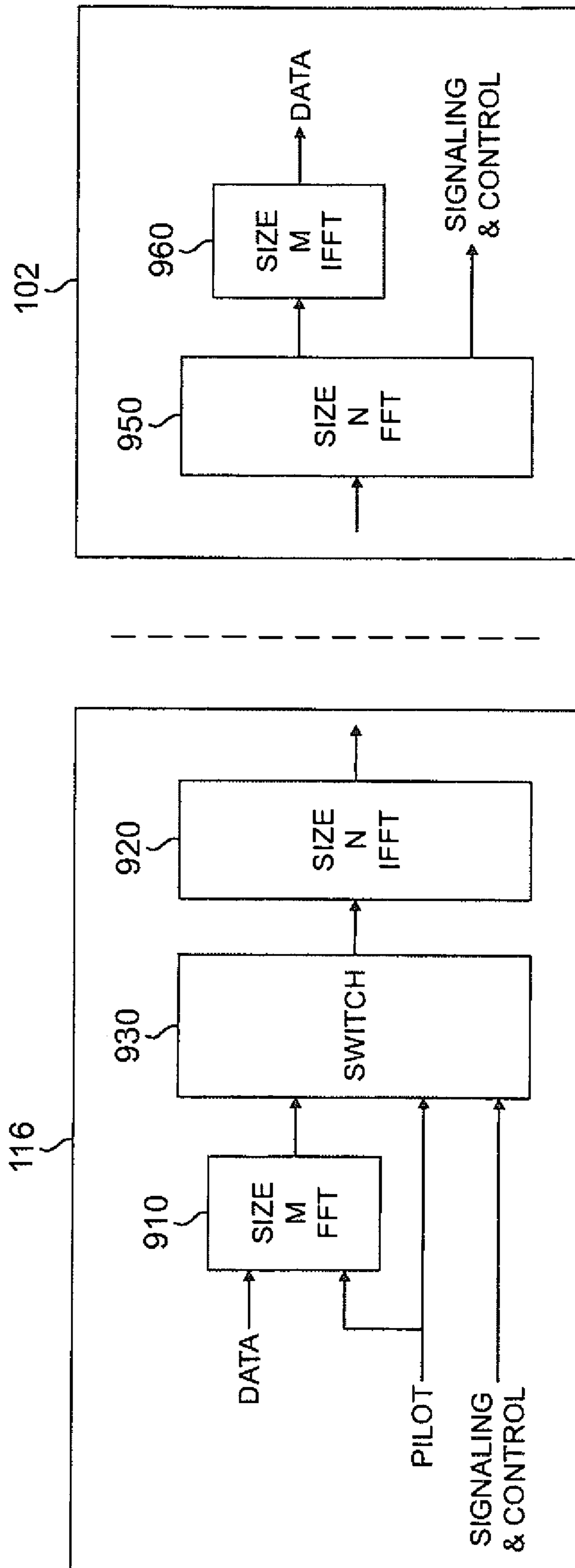

FIG. 9

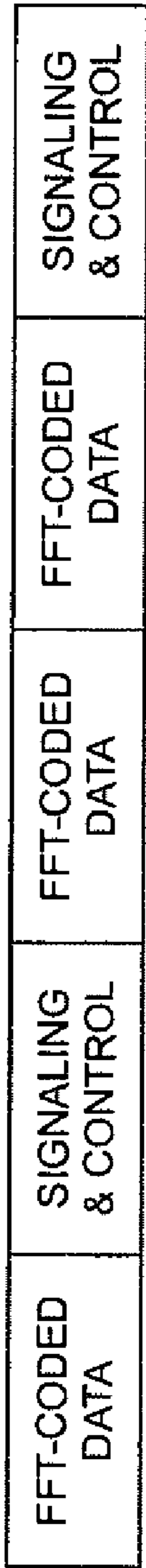

FIG. 10

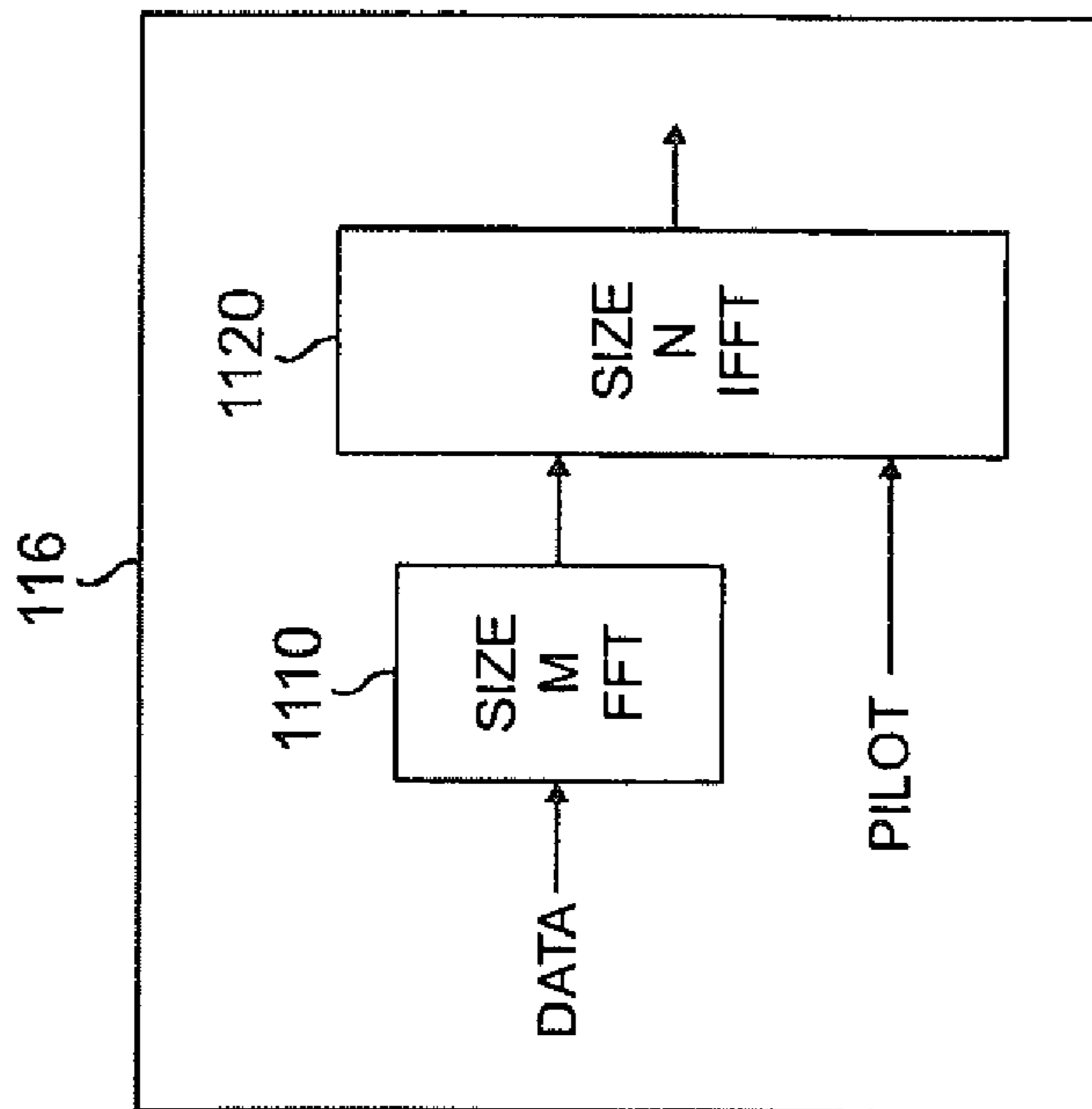
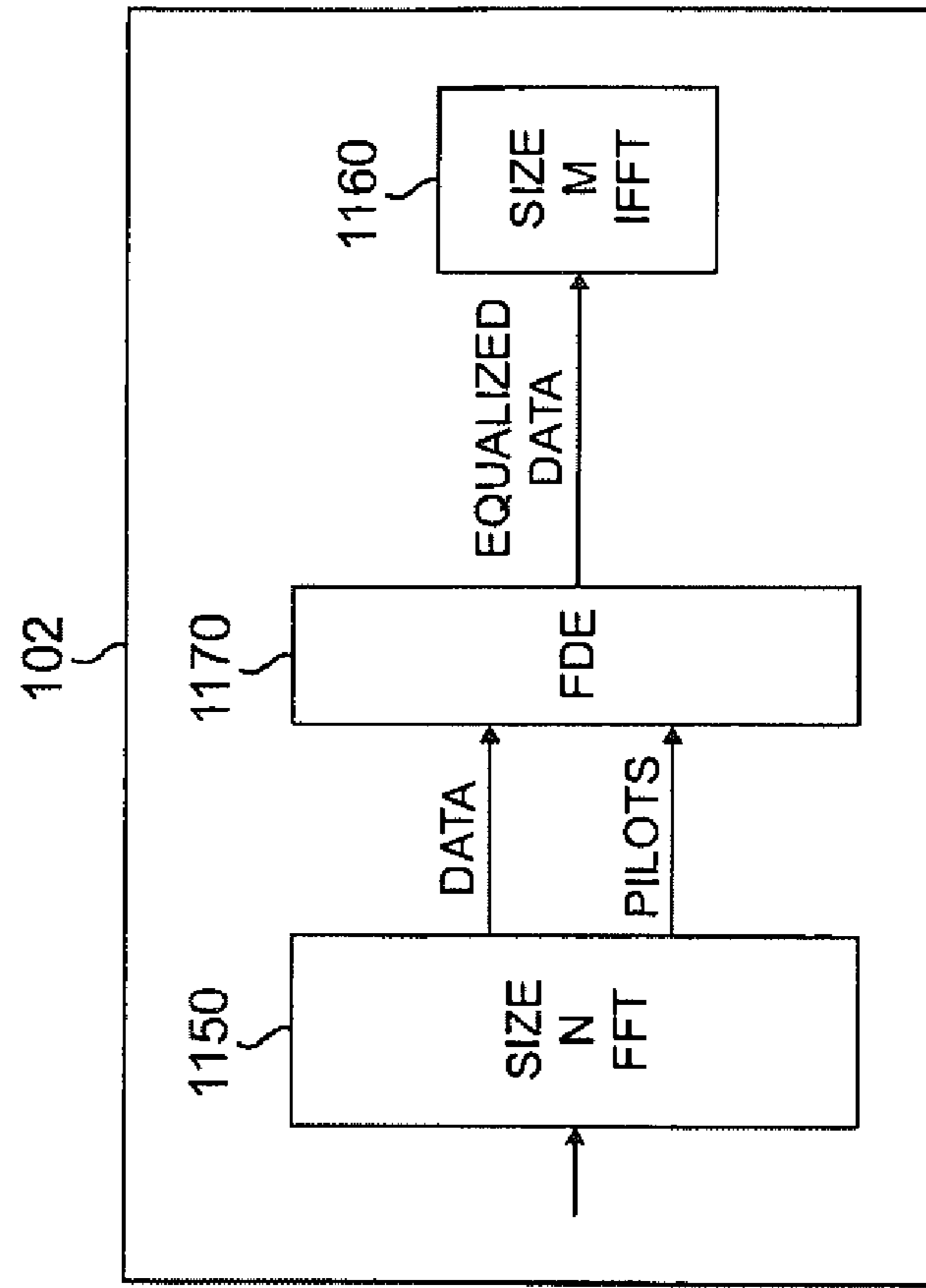

FIG. 11

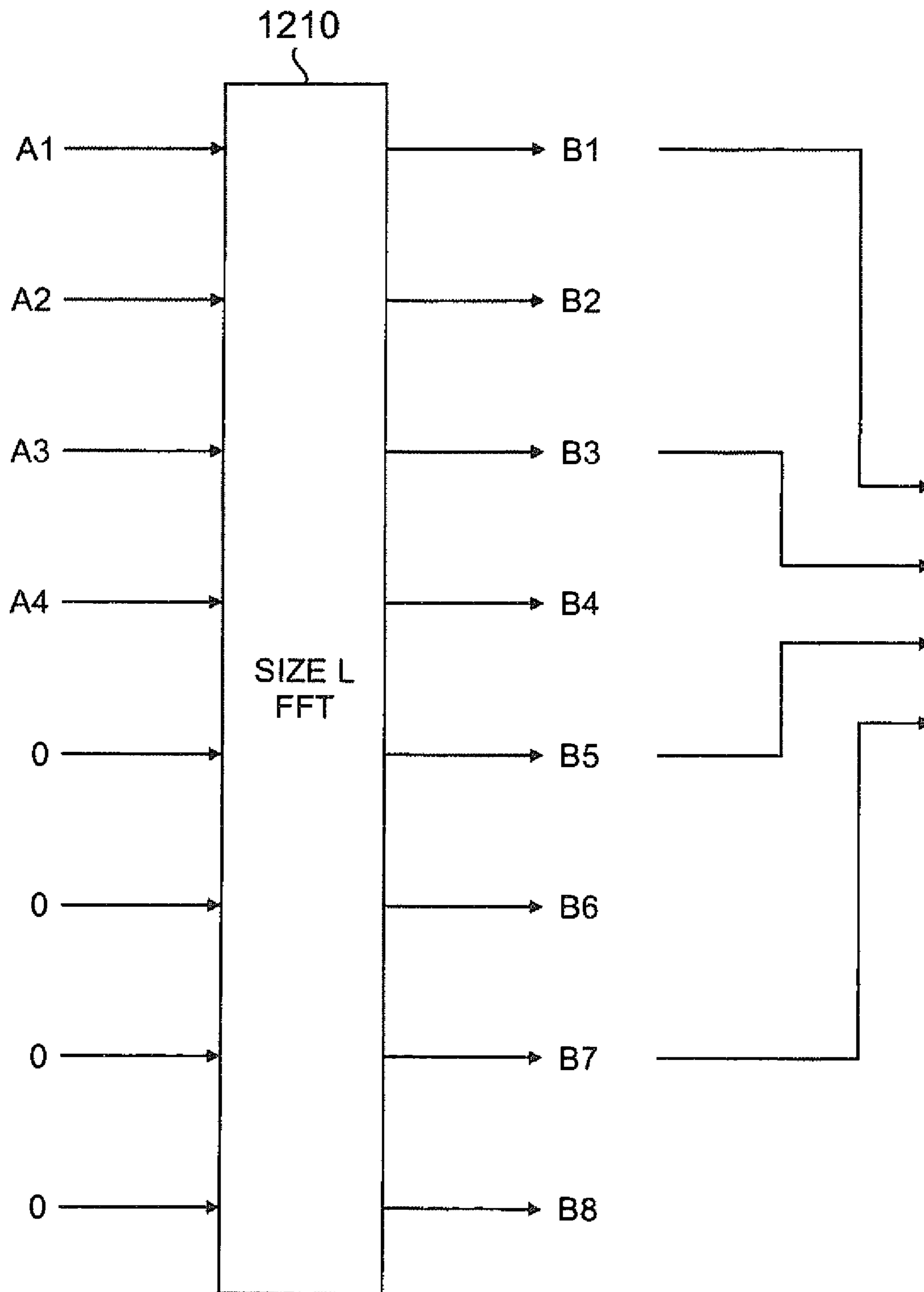

FIG. 12

**APPARATUS AND METHOD FOR FT
PRE-CODING OF DATA TO REDUCE PAPR IN
A MULTI-CARRIER WIRELESS NETWORK**

Matter enclosed in heavy brackets [] appears in the original patent but forms no part of this reissue specification; matter printed in italics indicates the additions made by reissue.

CROSS-REFERENCE TO RELATED
APPLICATION AND CLAIM OF PRIORITY

The present application is related to U.S. Provisional Patent No. 60/668,797, filed Apr. 6, 2005, entitled "Power Efficient OFDM Wireless Communication System". U.S. Provisional Patent No. 60/668,797 is assigned to the assignee of this application and is incorporated by reference as if fully set forth herein. The present application hereby claims priority under 35 U.S.C. §119(e) to U.S. Provisional Patent No. 60/668,797.

CROSS-REFERENCE TO RELATED
APPLICATION(S)

The present application is related to U.S. patent application Ser. No. 11/374,863, entitled "Apparatus and Method for FT Pre-Coding of Data and Control Signals To Reduce PAPR in a Multi-Carrier Wireless Network," filed concurrently herewith. Application Ser. No. 11/374,863 is assigned to the assignee of this application. The subject matter disclosed in application Ser. No. 11/374,863 is incorporated by reference as if fully set forth herein.

TECHNICAL FIELD OF THE INVENTION

The present application relates generally to wireless communications and, more specifically, to a mechanism for FFT pre-coding of data to reduce peak-to-average power ratio (PAPR) in a multi-carrier wireless network.

BACKGROUND OF THE INVENTION

orthogonal frequency division multiplexing (OFDM) is a multi-carrier transmission technique in which a user transmits on many orthogonal frequencies (or subcarriers). The orthogonal subcarriers are individually modulated and separated in frequency such that they do not interfere with one another. This provides high spectral efficiency and resistance to multipath effects. An orthogonal frequency division multiple access (OFDMA) system allows some subcarriers to be assigned to different users, rather than to a single user. Today, OFDM and OFDMA technology are used in both wireline transmission systems, such as asymmetric digital subscriber line (ADSL), and wireless transmission systems, such as IEEE-802.11a/g (i.e., WiFi), IEEE-802.16 (e.g., WiMAX), digital audio broadcast (DAB), and digital video broadcast (DVB). This technology is also used for wireless digital audio and video broadcasting.

Conventional power amplifiers for amplifying multi-carrier signals are relatively expensive parts of a communication system. A key design parameter for OFDM and OFDMA power amplifiers is the requirement to minimize the generation of adjacent channel power (ACP) noise. ACP noise results from signal distortion caused by operation of power amplifier components in non-linear regions of the input-output characteristic such as when the power amplifier enters

saturation. This distortion produces undesired spectral components in adjacent transmission channels.

Power amplifiers are more linear at lower input signal levels. Large input signals tend to drive a power amplifier into saturation. Thus, weaker signals experience less distortion and have lower ACP noise. However, a sudden large signal peak still results in distortion and ACP noise. This is especially problematic in systems that have large peak-to-average power ratios (i.e., high crest factors), such as OFDM and OFDMA systems. To avoid this, power amplifiers often operate in "back-off" mode (i.e., reduced input signal) in order to accommodate large signal peaks. However, operating in back-off mode requires the use of devices with higher power ratings which adds to system design, development and manufacturing costs. Furthermore, it may be inefficient and may generate excessive heat.

Therefore, there is a need for improved OFDM and OFDMA transmission system that minimize amplifier peak-to-average power ratio (PAPR) without suffering performance degradation.

SUMMARY OF THE INVENTION

A subscriber station is provided for use in a wireless network capable of communicating according to a multi-carrier protocol, such as OFDM or OFDMA. In one embodiment, the subscriber station comprises a size M Fourier Transform (FT) block capable of receiving input symbols and generating therefrom M FT pre-coded outputs; and a size N inverse Fourier Transform (IFT) block capable of receiving N inputs, where the N inputs include the M FT pre-coded outputs from the size M FT block. The size N IFFT block generates therefrom N outputs to be transmitted to a base station of the wireless network. The size M FT block and the size N IFT block are one of: 1) a size M Fast Fourier Transform (FFT) block and a size N inverse Fast Fourier Transform (IFFT) block; and 2) a size M Discrete Fourier Transform (DFT) block and a size N inverse Discrete Fourier Transform (IDFT) block. The input symbols comprise user data traffic to be transmitted to the base station. The size N IFT block also receives signaling and control information on at least some of the other N-M inputs. Advantageously, the FT pre-coding performed by the size M FT block generates a time-domain signal that has a relatively lower peak-to-average power ratio (PAPR).

A method also is provided for reducing the peak-to-average power ratio (PAPR) of a radio frequency signal transmitted by a subscriber station to a base station of a wireless network. The method comprises the steps of receiving input symbols to be transmitted to the base station; performing a size M Fourier Transform (FT) operation on the received input symbols to thereby generate M FT pre-coded outputs; and performing a size N inverse Fourier Transform (IFT) operation on N inputs, where the N inputs include the M FT pre-coded outputs. The IFT operation generates N outputs to be transmitted to the base station. The size M FT operation and the size N IFT operation are one of: 1) a size M Fast Fourier Transform (FFT) operation and a size N inverse Fast Fourier Transform (IFFT) operation; and 2) a size M Discrete Fourier Transform (DFT) operation and a size N inverse Discrete Fourier Transform (IDFT) operation.

In another embodiment, a base station is provided for use in a wireless network capable of communicating with subscriber stations according to a multi-carrier protocol. The base station comprises down-conversion circuitry for receiving incoming radio frequency signals from the subscriber stations and generating a baseband signal; a size N Fourier

Transform (FT) block for receiving the baseband signal on N inputs and performing an FT operation to generate N outputs; and a size M Inverse Fourier Transform (IFT) block for receiving M of the N outputs of the size N FT block and performing an IFT operation on the M outputs to generate a plurality of data symbols transmitted by a first one of the subscriber stations. The size N FT block and the size M IFT block are one of: 1) a size N Fast Fourier Transform (FFT) block and a size M inverse Fast Fourier Transform (IFFT) block; and 2) a size N Discrete Fourier Transform (DFT) block and a size M inverse Discrete Fourier Transform (IDFT) block.

Before undertaking the DETAILED DESCRIPTION OF THE INVENTION below, it may be advantageous to set forth definitions of certain words and phrases used throughout this patent document: the terms “include” and “comprise,” as well as derivatives thereof, mean inclusion without limitation; the term “or,” is inclusive, meaning and/or; the phrases “associated with” and “associated therewith,” as well as derivatives thereof, may mean to include, be included within, interconnect with, contain, be contained within, connect to or with, couple to or with, be communicable with, cooperate with, interleave, juxtapose, be proximate to, be bound to or with, have, have a property of, or the like; and the term “controller” means any device, system or part thereof that controls at least one operation, such a device may be implemented in hardware, firmware or software, or some combination of at least two of the same. It should be noted that the functionality associated with any particular controller may be centralized or distributed, whether locally or remotely. Definitions for certain words and phrases are provided throughout this patent document, those of ordinary skill in the art should understand that in many, if not most instances, such definitions apply to prior, as well as future uses of such defined words and phrases.

BRIEF DESCRIPTION OF THE DRAWINGS

For a more complete understanding of the present disclosure and its advantages, reference is now made to the following description taken in conjunction with the accompanying drawings, in which like reference numerals represent like parts:

FIG. 1 illustrates an exemplary wireless network that reduces the peak-to-average power ratio (PAPR) or crest factor of OFDM or OFDMA signals according to the principles of the present disclosure;

FIG. 2A is a high level block diagram of a conventional orthogonal frequency division multiple access (OFDMA) transmitter according to one embodiment of the prior art;

FIG. 2B is a high level block diagram of a conventional orthogonal frequency division multiple access (OFDMA) receiver according to one embodiment of the prior art;

FIG. 3 illustrates selected portions of a subscriber station and a base station that implement power-efficient multiplexing for reducing the peak-to-average power ratio (PAPR) or crest factor of OFDM or OFDMA signals according to the principles of the present disclosure;

FIG. 4 illustrates selected portions of subscriber stations and a base station in which selective FFT pre-coding of data in a power-limited subscriber station is implemented according to the principles of the present disclosure;

FIG. 5A is a high level block diagram of a subscriber station that implements FFT pre-coding according to one embodiment of the present disclosure;

FIG. 5B is a high level block diagram of a base station that supports FFT pre-coded data according to one embodiment of the present disclosure;

FIGS. 6A-6C illustrate the mapping of data signals and pilot signals to OFDM subcarriers according to different embodiments of the present disclosure;

FIG. 7 illustrates selected portions of a subscriber station and a base station that implement selective FFT pre-coding of data according to one embodiment of the present disclosure;

FIG. 8 illustrates selected portions of a subscriber station and a base station that implement selective FFT pre-coding of data according to another embodiment of the present disclosure;

FIG. 9 illustrates selected portions of a subscriber station and a base station that implement time-multiplexing of FFT pre-coded data with signaling and control information according to another embodiment of the present disclosure;

FIG. 10 illustrates time-multiplexed FFT pre-coded data and signaling and control information;

FIG. 11 illustrates selected portions of a subscriber station and a base station that implement selective FFT pre-coding of data and frequency domain equalization (FDE) according to another embodiment of the present disclosure; and

FIG. 12 illustrates FFT pre-coding of data according to an exemplary embodiment of the present disclosure.

DETAILED DESCRIPTION OF THE INVENTION

FIGS. 1 through 12, discussed below, and the various embodiments used to describe the principles of the present disclosure in this patent document are by way of illustration only and should not be construed in any way to limit the scope of the disclosure. Those skilled in the art will understand that the principles of the present disclosure may be implemented in any suitably arranged communication system.

A transmission technique is disclosed for reducing the peak-to-average power (PAPR) ratio—or crest factor—of the transmitted waveforms for multi-carrier signals, such as orthogonal frequency division multiplexing (OFDM) or orthogonal frequency division multiple access (OFDMA) signals. Reducing PAPR provides improved power amplifier efficiency, reduced heat dissipation requirements, smaller heat sinks, reduced power supply load, and lower cost for wireless base stations and subscriber stations. In the descriptions that follow, it shall be assumed generally that transmitters and receivers are operating in OFDMA mode. However, this embodiment should not be construed to limit the scope of the disclosure. In alternate embodiments, the transmitters and receivers may operate in OFDM mode or another multi-carrier mode without departing from the principles of the disclosure.

FIG. 1 illustrates exemplary wireless network 100, which reduces peak-to-average power ratio (PAPR) of multi-carrier signals, such as OFDM and OFDMA signals, according to the principles of the present disclosure. In the illustrated embodiment, wireless network 100 includes base station (BS) 101, base station (BS) 102, base station (BS) 103, and other similar base stations (not shown). Base station 101 is in communication with base station 102 and base station 103. Base station 101 is also in communication with Internet 130 or a similar IP-based network (not shown).

Base station 102 provides wireless broadband access (via base station 101) to Internet 130 to a first plurality of subscriber stations within coverage area 120 of base station 102. The first plurality of subscriber stations includes subscriber station 111, which may be located in a small business (SB), subscriber station 112, which may be located in an enterprise

5

(E), subscriber station **113**, which may be located in a WiFi hotspot (HS), subscriber station **114**, which may be located in a first residence (R), subscriber station **115**, which may be located in a second residence (R), and subscriber station **116**, which may be a mobile device (M), such as a cell phone, a wireless laptop, a wireless PDA, or the like.

Base station **103** provides wireless broadband access (via base station **101**) to Internet **130** to a second plurality of subscriber stations within coverage area **125** of base station **103**. The second plurality of subscriber stations includes subscriber station **115** and subscriber station **116**. In an exemplary embodiment, base stations **101-103** may communicate with each other and with subscriber stations **111-116** using OFDM or OFDMA techniques.

Base station **101** may be in communication with either a greater number or a lesser number of base stations. Furthermore, while only six subscriber stations are depicted in FIG. **1**, it is understood that wireless network **100** may provide wireless broadband access to additional subscriber stations. It is noted that subscriber station **115** and subscriber station **116** are located on the edges of both coverage area **120** and coverage area **125**. Subscriber station **115** and subscriber station **116** each communicate with both base station **102** and base station **103** and may be said to be operating in handoff mode, as known to those of skill in the art.

Subscriber stations **111-116** may access voice, data, video, video conferencing, and/or other broadband services via Internet **130**. In an exemplary embodiment, one or more of subscriber stations **111-116** may be associated with an access point (AP) of a WiFi WLAN. Subscriber station **116** may be any of a number of mobile devices, including a wireless-enabled laptop computer, personal data assistant, notebook, handheld device, or other wireless-enabled device. Subscriber stations **114** and **115** may be, for example, a wireless-enabled personal computer (PC), a laptop computer, a gateway, or another device.

FIG. **2A** is a high-level diagram of conventional orthogonal frequency division multiple access (OFDMA) transmitter **200**. FIG. **2B** is a high-level diagram of conventional orthogonal frequency division multiple access (OFDMA) receiver **250**. OFDMA transmitter **200** comprises quadrature amplitude modulation (QAM) modulator **205**, serial-to-parallel (S-to-P) block **210**, Size N Inverse Fast Fourier Transform (IFFT) block **215**, parallel-to-serial (P-to-S) block **220**, add cyclic prefix block **225**, and up-converter (UC) **230**. OFDMA receiver **250** comprises down-converter (DC) **255**, remove cyclic prefix block **260**, serial-to-parallel (S-to-P) block **265**, Size N Fast Fourier Transform (FFT) block **270**, parallel-to-serial (P-to-S) block **275**, and quadrature amplitude modulation (QAM) demodulator **280**.

At least some of the components in FIGS. **2A** and **2B** may be implemented in software while other components may be implemented by configurable hardware or a mixture of software and configurable hardware. In particular, it is noted that the FFT blocks and the IFFT blocks described in this disclosure document may be implemented as configurable software algorithms, where the values of Size M and Size N may be modified according to the implementation.

Furthermore, although the text and FIGS. **1-12** of the disclosure are directed to an embodiment that implements the Fast Fourier Transform and the Inverse Fast Fourier Transform, this is by way of illustration only and should not be construed to limit the scope of this disclosure. It will be appreciated that in an alternate embodiment of the disclosure, the Fast Fourier Transform functions and the Inverse Fast Fourier Transform functions may easily be replaced by Discrete Fourier Transform (DFT) functions and Inverse Dis-

6

crete Fourier Transform (IDFT) functions, respectively. It will be appreciated that for DFT and IDFT functions, the values of the M and N variables may be any integer numbers (i.e., 1, 2, 3, 4, etc.), while for FFT and IFFT functions, the values of the M and N variables may be any integer numbers that are powers of two (i.e., 1, 2, 4, 8, 16, etc.).

In OFDMA transmitter **200**, QAM modulator **205** receives a set of information bits and modulates the input bits to produce a sequence of frequency-domain modulation symbols. Serial-to-parallel block **210** converts (i.e., de-multiplexes) the serial QAM symbols to parallel data to produce N parallel symbol streams where N is the IFFT/FFT size used in transmitter **200** and receiver **250**. Size N IFFT block **215** then performs an IFFT operation on the N parallel symbol streams to produce time-domain output signals. Parallel-to-serial block **220** converts (i.e., multiplexes) the parallel time-domain output symbols from Size N IFFT block **215** to produce a serial time-domain signal. Add cyclic prefix block **225** then inserts a cyclic prefix to the time-domain signal.

Finally, up-converter **230** modulates (i.e., up-converts) the output of add cyclic prefix block **225** to RF frequency for transmission via a wireless channel. The signal may also be filtered at baseband before conversion to RF frequency. The time-domain signal transmitted by OFDMA transmitter **200** comprises multiple overlapping sinusoidal signals corresponding to the data symbols transmitted. This results in a large peak-to-average power ratio (PAPR) at the transmitter amplifier and requires significant transmit power back-offs.

The transmitted RF signal arrives at OFDMA receiver **250** after passing through the wireless channel and reverse operations to those at OFDMA transmitter **200** are performed. Down-converter **255** down-converts the received signal to baseband frequency and remove cyclic prefix **260** removes the cyclic prefix to produce the serial time-domain baseband signal. Serial-to-parallel block **265** converts the time-domain baseband signal to parallel time domain signals. Size N FFT block **270** then performs an FFT algorithm to produce N parallel frequency-domain signals. Parallel-to-serial block **275** converts the parallel frequency-domain signals to a sequence of QAM data symbols. QAM demodulator **280** then demodulates the QAM symbols to recover the original input data stream.

FIG. **3** illustrates selected portions of subscriber station **116** and base station **102**, which implement power-efficient FFT pre-coding for reducing the peak-to-average power ratio (PAPR) of OFDMA signals according to the principles of the present disclosure. Subscriber station **116** comprises Size M Fast Fourier Transform (FFT) block **310** and Size N Inverse Fast Fourier Transform (IFFT) block **320**. Base station **102** comprises Size N Fast Fourier Transform (FFT) block **350** and Size M Inverse Fast Fourier Transform (IFFT) block **360**. According to the principles of the disclosure, prior to the IFFT operation in subscriber station **116**, at least a portion of the user data traffic and/or the pilot, signaling, and other control signals are pre-coded by means of an FFT operation in order to reduce the PAPR of the transmitted signal.

In FIG. **3**, Size M FFT block **310** pre-codes at least some of the data traffic by performing a size M FFT operation. The FFT pre-coded data are then mapped to a subset of the OFDMA subcarriers (i.e., tones) and a size N IFFT operation is performed, where N is greater than or equal to M. The FFT pre-coding performed by Size M FFT block **310** results in a time-domain signal that has relatively lower PAPR, thus making efficient use of the capacity of the power amplifier (not shown) in subscriber station **116**. In FIG. **3**, the signaling and control information, such as pilot signals, are directly mapped to the OFDM subcarriers without FFT pre-coding. In general,

signaling and control information is transmitted at lower power than user data symbols and thus contributes less to the overall PAPR.

In base station **102**, Size N FFT block **350** performs a size N FFT operation on the received signal to recover the FFT pre-coded data and the non-coded signaling and control information. The data symbols may be equalized (not shown) in the frequency-domain using the frequency-domain pilot information. After equalization, Size M IFFT block **360** performs an IFFT operation on the equalized pre-coded symbols to recover the original user data traffic.

FIG. **4** illustrates selected portions of subscriber stations **116** and **115** and base station **102** in which selective FFT pre-coding of data in power-limited subscriber station **116** is implemented according to the principles of the disclosure. Subscriber station (SS) **116** comprises Size M Fast Fourier Transform (FFT) block **410a** and Size N Inverse Fast Fourier Transform (IFFT) block **420a**. Subscriber station (SS) **115** comprises Size N Inverse Fast Fourier Transform (IFFT) block **420b**. Base station (BS) **102** comprises Size N Fast Fourier Transform (FFT) block **450** and Size M Inverse Fast Fourier Transform (IFFT) block **460**.

In FIG. **4**, SS **116** is power-limited (e.g., near cell edge) and must perform FFT pre-coding. However, SS **115** is not power-limited (e.g., near BS **102**) and the FFT pre-coding step is omitted. Hence, the data in SS **115** is directly mapped to the OFDM subcarriers. The signal from SS **115** may result in potentially higher PAPR. However, SS **115** can back-off the transmit power in the uplink from its peak power because SS **115** has excess power headroom available.

SS **116** uses a control message to indicate to BS **102** that SS **116** is operating in power limited mode. Similarly, SS **115** may indicate to BS **102** that SS **115** is not operating in power-limited mode. Thus, BS **102** knows which subscriber stations are using FFT pre-coding and which subscriber stations are not. As a result, in base station **102**, Size N FFT block **450** performs a size N FFT operation on the received signal to recover the incoming signals from SS **115** and SS **116**. However, Size M IFFT block **460a** performs an IFFT operation only on FFT pre-coded data from SS **116**. The signaling and control information from SS **116** and the data traffic and signaling and control information from SS **115** are recovered directly from the outputs of Size N FFT block **450**.

FIG. **5A** is a high level block diagram of subscriber station **116**, which implements FFT pre-coding according to the principles of the present disclosure. FIG. **5B** is a high level block diagram of base station **102**, which supports FFT pre-coded data according to the principles of the present disclosure. Subscriber station **116** comprises channel coding and QAM modulation block **505**, Size M FFT block **510**, M subcarriers (SC) mapping block **515**, Size N IFFT block **520**, and add cyclic prefix block **525**. Base station **102** comprises remove cyclic prefix block **555**, Size N FFT block **560**, M subcarriers demapping block **565**, Size M IFFT block **570**, and channel decoding and QAM demodulation block **575**.

Channel coding and QAM modulation block **505** receives incoming data traffic bits and performs channel coding (e.g., turbo coding, Viterbi coding, etc.) and modulation to produce a stream of symbols. Size M FFT block **510** then FFT pre-codes the data symbols by performing a size M FFT operation. After the FFT operation, M subcarrier mapping block **515** maps the FFT pre-coded symbols to M subcarriers out of a total of N subcarriers at the inputs of Size N IFFT block **520**. Any additional control information, such as a pilot signal, is also mapped to predetermined subcarriers inputs of Size N IFFT block **520**. Next, Size N IFFT block **520** performs a size N IFFT operation to generate a time domain signal. Add

cyclic prefix block **525** adds a cyclic prefix to the time-domain signal from Size N IFFT block **520** before up-conversion (not shown) to the RF frequency for transmission.

A sequence of reverse operations is performed in base station (BS) **102**. BS **102** comprises down-conversion circuitry (not shown) that generates a baseband signal from the received RF signal. After down-conversion, remove cyclic prefix block **555** removes the cyclic prefix from the time-domain baseband signal. Size N FFT block **560** converts the baseband signal to a frequency domain signal. The control and signaling information that was not FFT pre-coded is recovered directly from the outputs of Size N FFT block **560**. M subcarriers demapping block **565** demaps the FFT pre-coded data from selected ones of the outputs of Size N FFT block **560** to the inputs Size M IFFT block **570**. Size M IFFT block **570** receives the FFT pre-coded data traffic from M subcarriers demapping block **565** and performs a size M IFFT operation to recover the coded and modulated data symbols. Finally, channel decoding and QAM demodulation block **575** demodulates and decodes the data symbols to recover the original user data traffic bits.

FIGS. **6A-6C** illustrate the mapping of data signals and pilot signals to OFDM/OFDMA subcarriers according to different embodiments of the present disclosure. FIG. **6A** illustrates the mapping of data and pilot symbols to selected subsets of thirty-two (32) subcarriers for FFT pre-coding. In this example, both User A (e.g., SS **116**) and User B (e.g., SS **116**) use 16 subcarriers each for data and pilot signal out of a total of 32 subcarriers. The first 16 subcarriers are used by User A and the remaining 16 subcarriers are used by User B. Also, the pilot symbols are interspersed uniformly among the data symbols.

FIG. **6B** illustrates another mapping of data and pilot symbols to selected subsets of thirty-two (32) subcarriers for FFT pre-coding. In FIG. **6B**, the data symbols for User-A and the pilot symbols for User A are scattered uniformly (interspersed) over the whole bandwidth of the 32 subcarriers. User A data symbols uses subcarrier frequencies **f1**, **f5**, **f9**, **f13**, **f17**, **f21**, **f25** and **f29** and User A pilot symbols use subcarrier frequencies **f2**, **f6**, **f10**, **f14**, **f18**, **f22**, **f26** and **f30**. Similarly, User B data symbols and pilot symbols (not shown) are over the remaining subcarriers in FIG. **6B**. Interspersing the data and pilot signals of different users achieves frequency-diversity because the data for both User A and User B are scattered over the whole bandwidth.

FIG. **6C** illustrates another mapping of data and pilot symbols to selected subsets of thirty-two (32) subcarriers for FFT pre-coding. In this embodiment, User A is power-limited and the User A FFT pre-coded data is uniformly distributed over subcarriers in the whole frequency band used (i.e., on subcarriers **f1**, **f9**, **f17** and **f25**). The mapping of FFT-coded data in this way results in a time-domain signal after the IFFT operation that has low PAPR. User B is not power-limited and User B maps FFT pre-coded data to a contiguous set of subcarriers (e.g., subcarriers **f3**, **f4**, **f5**, **f6**, **f7** and **f8**). The mapping of FFT pre-coded data to a contiguous set of subcarriers results in relatively larger PAPR. However, since user-B is not power limited, User B can back-off its power amplifier appropriately in order to satisfy the higher PAPR constraint.

FIG. **7** illustrates selected portions of subscriber station **116** and base station **102** that implement selective FFT pre-coding of data according to one embodiment of the present disclosure. In this embodiment, Size M FFT block **710** pre-codes user data and Size N IFFT block **720** performs an IFFT operation (i.e., multiplexes) on the FFT pre-coded data and the non-FFT pre-coded signaling information, namely the pilot signals, resource request signals, random access signals,

and channel quality indicator (CQI) feedback signals. Other kinds of control information, such as acknowledgment (ACK) feedback or negative acknowledgment (NACK) feedback for hybrid ARQ operation may be multiplexed using the teachings of this invention. In BS **102**, Size N FFT block **750** recovers the FFT pre-coded data and the non-FFT pre-coded pilot signals, resource request signals, random access signals and channel quality indicator (CQI) feedback signals. Size M IFFT block **760** then recovers the original data symbols from the FFT pre-coded data.

FIG. **8** illustrates selected portions of subscriber station **116** and base station **102** that implement selective FFT pre-coding of data according to another embodiment of the present disclosure. In this embodiment, Size M FFT block **810** pre-codes not only the user data, but also FFT pre-codes some of the control and signaling information—in this case, the pilot signal(s). Size N IFFT block **820** then performs an IFFT operation (i.e., multiplexes) the FFT pre-coded data, the FFT pre-coded pilot signal, and the non-FFT pre-coded resource request signals, random access signals and channel quality indicator (CQI) feedback signals. In BS **102**, Size N FFT block **850** recovers the FFT pre-coded data, the FFT pre-coded pilot signal(s), and the non-FFT pre-coded resource request signals, random access signals, and channel quality indicator (CQI) feedback signals. Size M IFFT block **860** then recovers the original data symbols from the FFT pre-coded data and the original pilot signal(s) from the FFT pre-coded pilot signal.

FIG. **9** illustrates selected portions of subscriber station **116** and base station **102** that implement time-multiplexing of FFT pre-coded data with signaling and control information according to another embodiment of the present disclosure. FIG. **10** illustrates time-multiplexed FFT pre-coded data and signaling and control information. SS **116** comprises Size M FFT block **910**, Size N IFFT block **920** and switch **930**. Switch **930** provides the ability to implement time-multiplexing. BS **102** comprises Size N FFT block **950** and Size M IFFT block **960**.

At a given time, switch **930** enables either the transmission of FFT pre-coded data from Size M FFT block **910** or the transmission of signaling and control information. This is illustrated in FIG. **10**. The transmission of signaling and control information is interrupted when data needs to be transmitted so that required resources for data can be allocated.

FIG. **11** illustrates selected portions of subscriber station (SS) **116** and base station (BS) **102** that implement selective FFT pre-coding of data and frequency domain equalization (FDE) according to another embodiment of the present disclosure. SS **116** comprises Size M FFT block **1110** and Size N IFFT block **1120**. BS **102** comprises Size N FFT block **1150**, Size M IFFT block **1160**, and frequency domain equalizer (FDE) **1170**.

Size M FFT block **1110** pre-codes the data traffic by performing a size M FFT operation. The FFT pre-coded data are then mapped to a subset ($=M$) of the OFDMA subcarriers (i.e., tones) and Size N IFFT block **1120** performs a size N IFFT operation ($N>M$) on the FFT pre-coded data symbols, the pilot signal, and other signaling and control information not shown. The pilot signal and other control and signaling information are directly mapped to the OFDM subcarriers without FFT pre-coding.

In base station **102**, Size N FFT block **1150** performs a size N FFT operation on the received signal to recover the FFT pre-coded data, the non-FFT pre-coded pilot signal, and the other non-FFT pre-coded signaling and control information (not shown). Next, FDE **1170** uses the recovered pilot signal

to equalize the FFT pre-coded data in the frequency-domain. The received frequency-domain pilot information is used for channel estimation and equalization purposes. It is noted that the pilot symbols were inserted in SS **116** just before the IFFT operation, so that FFT pre-coding is not used for the pilot symbols. Therefore, pilot symbol transmission happens in the frequency-domain. This assures that a reliable channel estimate is available in the frequency-domain for frequency-domain equalization. Finally, Size M IFFT block **1160** converts the equalized data symbols from the frequency domain to the time domain.

FIG. **12** illustrates FFT pre-coding of data according to an exemplary embodiment of the present disclosure. In the example, it is desired to perform a size $K=4$ FFT pre-coding operation using Size L FFT block **1210**, where $L=8$. A size K FFT operation can be performed using Size L FFT block **1210** by mapping the K input symbols into K contiguous inputs of the total of L inputs. The remaining $(L-K)$ inputs of Size L FFT block **1210** are set to 0. The K outputs are obtained by reading every L/K output as illustrated in FIG. **12**. For the case of $K=4$ and $L=8$, this means reading every second output (i.e., every other output). Therefore, any data FFT pre-coding of size K (limited by the maximum FFT size L) may be done to match the amount of data to be transmitted from a subscriber station and to match the number of subcarriers allocated to the subscriber station.

As noted above, in an alternate embodiment of the present disclosure, Discrete Fourier Transform (DFT) functions and Inverse Discrete Fourier Transform (IDFT) functions may be used in lieu of Fast Fourier Transform functions and Inverse Fast Fourier Transform, respectively. In such an embodiment, the FFT blocks and the IFFT blocks in the figures above may be replaced by DFT blocks and IDFT blocks.

Although the present disclosure has been described with an exemplary embodiment, various changes and modifications may be suggested to one skilled in the art. It is intended that the present disclosure encompass such changes and modifications as fall within the scope of the appended claims.

What is claimed is:

1. For use in a wireless network, a subscriber station capable of communicating with the wireless network according to a multi-carrier protocol, the subscriber station comprising:

a size M Fourier Transform (FT) block capable of receiving input symbols and generating therefrom M FT pre-coded outputs, the input symbols comprising data signals and pilot signals; and

a size N inverse Fourier Transform (IFT) block capable of receiving N inputs, the N inputs including the M FT pre-coded outputs from the size M FT block, and generating therefrom N outputs to be transmitted to a base station of the wireless network, wherein the size M FT block and the size N IFT block are one of: 1) a Fast Fourier Transform (FFT) block and an inverse Fast Fourier Transform (IFFT) block; and 2) a Discrete Fourier Transform (DFT) block and an inverse Discrete Fourier Transform (IDFT) block,

wherein the data signals and pilot signals are mapped to alternating subcarriers and the size N IFT block receives signaling and control information on at least some of the N inputs other than the M FT pre-coded outputs.

2. The subscriber station as set forth in claim **1**, wherein the signaling and control information comprises a pilot signal.

3. The subscriber station as set forth in claim **1**, wherein the size N IFT block receives only the M FT pre-coded outputs during selected time slots and receives only the signaling and control information during other selected time slots.

11

4. The subscriber station as set forth in claim 1, wherein the multi-carrier protocol comprises one of orthogonal frequency division multiplexing and orthogonal frequency division multiple access.

5. The subscriber station as set forth in claim 1, wherein the input symbols further comprise a pilot signal.

6. The subscriber station as set forth in claim 5, [wherein the size N IFT block receives signaling and control information on at least some of the N inputs other than the M FT pre-coded outputs] *further comprising a switch configured to couple the size M FT block to the size N IFT.*

7. The subscriber station as set forth in claim 6, wherein the size N IFT block receives only the M FT pre-coded outputs during selected time slots and receives only the signaling and control information during other selected time slots.

8. The subscriber station as set forth in claim 7, wherein the signaling and control information comprises a pilot signal.

9. The subscriber station as set forth in claim 6, wherein the multi-carrier protocol comprises one of orthogonal frequency division multiplexing and orthogonal frequency division multiple access.

10. For use in a subscriber station capable of communicating with a wireless network according to a multi-carrier protocol, a method for reducing the peak-to-average power ration (PAPR) of a radio frequency signal transmitted by the subscriber station to a base station of the wireless network, the method comprising [the steps of]:

receiving input symbols to be transmitted to the base station, the input symbols comprising data signals and pilot signals;

performing a size M Fourier Transform (FT) operation on the received input symbols to thereby generate M FT pre-coded outputs; and

performing a size N inverse Fourier Transform (IFT) operation on N inputs, the N inputs including the M FT pre-coded outputs, to thereby generate N outputs to be transmitted to the base station, wherein the size M FT operation and the size N IFT operation are one of: 1) a Fast Fourier Transform (FFT) operation and an inverse Fast Fourier Transform (IFFT) operation; and 2) a Discrete Fourier Transform (DFT) operation and an inverse Discrete Fourier Transform (IDFT) operation mapping the data signals and pilot signals to alternating subcarriers, wherein the size N IFT operation receives signaling and control information on at least some of the N inputs other than the M FT pre-coded outputs.

11. The method as set forth in claim 10, wherein the signaling and control information comprises a pilot signal.

12. The method as set forth in claim 10, wherein the size N IFT operation is performed only on the M FT pre-coded outputs during selected time slots and is performed only on the signaling and control information during other selected time slots.

13. The method as set forth in claim 10, wherein the multi-carrier protocol comprises one of orthogonal frequency division multiplexing and orthogonal frequency division multiple access.

14. The method as set forth in claim 10, wherein the input symbols further comprise a pilot signal.

15. The method as set forth in claim 14, wherein the size N IFT operation receives signaling and control information on at least some of the N inputs other than the M FT pre-coded outputs.

16. The method as set forth in claim 15, wherein the size N IFT operation is performed only on the M FT pre-coded

12

outputs during selected time slots and is performed only on the signaling and control information during other selected time slots.

17. The method as set forth in claim 16, wherein the signaling and control information comprises a pilot signal.

18. The method as set forth in claim 15, wherein the multi-carrier protocol comprises one of orthogonal frequency division multiplexing and orthogonal frequency division multiple access.

19. A base station for use in a wireless network capable of communicating with subscriber stations according to a multi-carrier protocol, the base station comprising:

down-conversion circuitry capable of receiving incoming radio frequency signals from the subscriber stations and generating therefrom a baseband signal;

a size N Fourier Transform (FT) block capable of receiving the baseband signal on N inputs and performing an FT operation to generate N outputs;

a size M Inverse Fourier Transform (IFT) block capable of receiving M of the N outputs of the size N FT block and performing a size M IFT operation on the M outputs to generate a plurality of data symbols transmitted by a first one of the subscriber stations, wherein the size N FT block and the size M IFT block are one of 1) a Fast Fourier Transform (FFT) block and an inverse Fast Fourier Transform (IFFT) block; and 2) a Discrete Fourier Transform (DFT) block and an inverse Discrete Fourier Transform (IDFT) block; and

a frequency-domain equalizer capable of receiving a pilot signal transmitted by the first subscriber station and using the pilot signal to perform frequency-domain equalization on the M outputs of the size N FT block prior to the size M IFT operation of the size M IFT block wherein the size N FT block generates on at least some of the N outputs signaling and control information transmitted by the first subscriber station.

20. The base station as set forth in claim 19, wherein the signaling and control information transmitted by the first subscriber station comprises the pilot signal.

21. The base station as set forth in claim 20, wherein the data symbols transmitted by the first subscriber station are pre-coded.

22. A method for use in base station of a wireless network capable of communicating with subscriber stations according to a multi-carrier protocol, the method comprising [the steps of]:

receiving incoming radio frequency (RF) signals from the subscriber stations;

down-converting the incoming RF signals to generate a baseband signal;

performing a size N Fourier Transform (FT) operation on the baseband signal to generate N outputs;

performing a size M Inverse Fourier Transform (IFT) operation on M of the N outputs of the size N FT operation to generate a plurality of data symbols transmitted by a first one of the subscriber stations, wherein the size N FT operation and the size M IFT operation are one of: 1) a Fast Fourier Transform (FFT) operation and an inverse Fast Fourier Transform (LEFT) operation; and 2) a Discrete Fourier Transform (DFT) operation and an inverse Discrete Fourier Transform (IDFT) operation; and

using a pilot signal transmitted by the first subscriber station to perform frequency-domain equalization on the M outputs of the size N FT operation prior to the size M IFT operation, wherein the size N FT operation generates on

13

at least some of the N outputs signaling and control information transmitted by the first subscriber station.

23. The method as set forth in claim 22, wherein the signaling and control information transmitted by the first subscriber station comprises the pilot signal.

24. The method as set forth in claim 23, wherein the data symbols transmitted by the first subscriber station are pre-coded.

25. A wireless network comprising a plurality of base stations capable of communicating with subscriber stations according to a multi-carrier protocol, each of the base stations comprising:

down-conversion circuitry capable of receiving incoming radio frequency signals from the subscriber stations and generating therefrom a baseband signal;

a size N Fourier Transform (FT) block capable of receiving the baseband signal on N inputs and performing an IFT operation to generate N outputs;

a size M Inverse Fourier Transform (IFT) block capable of receiving M of the N outputs of the size N FT block and performing a size M IFT operation on the M outputs to generate a plurality of data symbols transmitted by a first one of the subscriber stations, wherein the size N FT block and the size M IFT block are one of: 1) a Fast Fourier Transform (FFT) block and an inverse Fast Fourier Transform (IFFT) block; and 2) a Discrete Fourier Transform (DFT) block and an inverse Discrete Fourier Transform (IDFT) block; and

a frequency-domain equalizer capable of receiving a pilot signal transmitted by the first subscriber station and using the pilot signal to perform frequency-domain equalization on the M outputs of the size N FT block prior to the size M IFT operation of the size M IFT block wherein the size N FT block generates on at least some of the N outputs signaling and control information transmitted by the first subscriber station.

26. The wireless network as set forth in claim 25, wherein the signaling and control information transmitted by the first subscriber station comprises the pilot signal.

27. The wireless network as set forth in claim 26, wherein the data symbols transmitted by the first subscriber station are pre-coded.

28. A data transmission method in a communication system, the method comprising:

modulating data information to generate non-FT pre-coded modulation data symbols;

modulating control information to generate non-FT pre-coded modulation control symbols;

Fourier Transform (FT) pre-coding the non-FT pre-coded modulation data symbols to generate FT pre-coded symbols;

mapping the FT pre-coded symbols to a first set of subcarriers;

mapping the non-FT pre-coded modulation control symbols to a second set of subcarriers;

performing an inverse Fourier Transform (IFT) operation on at least one of (i) the FT pre-coded symbols based on the first set of subcarriers and (ii) the non-FT pre-coded modulation control symbols based on the second set of subcarriers to generate an output signal; and

transmitting the output signal.

29. The method of claim 28, wherein FT pre-coding comprises performing an M point FT operation, performing the IFT operation comprising performing an N point IFT operation, and N is not less than M.

30. The method of claim 28, wherein performing the IFT operation comprises performing the IFT operation on both

14

the FT pre-coded symbols based on the first set of subcarriers and the non-FT pre-coded modulation control symbols based on the second set of subcarriers.

31. The method of claim 28, wherein performing the IFT operation comprising, based on time multiplexing, performing the IFT operation on one of (i) the FT pre-coded symbols based on the first set of subcarriers and (ii) the non-FT pre-coded modulation control symbols based on the second set of subcarriers.

32. The method of claim 30, wherein the control information comprises at least one of a pilot signal, a resource request, a random access, Channel Quality Indicator (CQI) and a feedback for hybrid automatic repeat request (HARQ).

33. A method for receiving data in a communication system, the method comprising:

receiving a transmitted signal;

performing a Fourier Transform (FT) operation on the received signal to generate N outputs, wherein a first subset of the N outputs comprises FT pre-coded modulated data symbols and a second subset of the N outputs comprises non-FT pre-coded modulated control symbols;

demapping the first subset of outputs;

performing Inverse Fourier Transform (IFT) operation on the demapped outputs to recover modulated data symbols; and

demodulating the modulated data symbols.

34. The method of claim 33, wherein the first subset further comprises FT pre-coded modulated control symbols, wherein performing the IFT operation further comprises performing the IFT operation to recover modulated control symbols, and the method further comprising demodulating the modulated control symbols.

35. The method of claim 33, further comprising: recovering the non-FT pre-coded modulated control symbols from the second subset of the N outputs; and demodulating the non-FT pre-coded modulated control symbols.

36. The method of claim 35, wherein the first subset of the N outputs further comprises a pilot signal, wherein the second subset of the N outputs comprises control information other than the pilot signal, wherein performing the IFT operation further comprises performing the IFT operation to recover modulated pilot symbols, and the method further comprising demodulating the modulated pilot symbols.

37. The method of claim 33, wherein the non-FT pre-coded modulated control symbols comprise control information, and wherein the control information comprises at least one of a pilot signal, a resource request, a random access, Channel Quality Indicator (CQI) and a feedback for HARQ.

38. An apparatus for data transmission in a communication system, the apparatus comprising:

a modulation block configured to modulate data information to generate non-FT pre-coded modulation data symbols and control information to generate non-FT pre-coded modulation control symbols;

a Fourier Transform (FT) block configured to FT pre-code the non-FT pre-coded modulation data symbols to generate FT pre-coded symbols;

a subcarrier mapping block configured to map the FT pre-coded symbols to a first set of subcarriers and the non-FT pre-coded modulation control symbols to a second set of subcarriers; and

an inverse FT (IFT) block configured to perform an IFT operation on at least one of (i) the FT pre-coded symbols based on the first set of subcarriers and (ii) the non-FT

15

pre-coded modulation control symbols based on the second set of subcarriers to generate an output signal, wherein the apparatus is configured to transmit the output signal.

39. *The apparatus of claim 38, wherein the FT block performs an M point FT operation, the IFT block performs an N point IFT operation, and N is not less than M.*

40. *The apparatus of claim 38, wherein the IFT block is configured to perform the IFT operation on both the FT pre-coded symbols based on the first set of subcarriers and the non-FT pre-coded modulation control symbols based on the second set of subcarriers.*

41. *The apparatus of claim 38, wherein based on time multiplexing, the IFT block is configured to perform the IFT operation on one of (i) the FT pre-coded symbols based on the first set of subcarriers and (ii) the non-FT pre-coded modulation control symbols based on the second set of subcarriers.*

42. *The apparatus of claim 40, wherein the control information comprises at least one of a pilot signal, a resource request, a random access, Channel Quality Indicator (CQI) and a feedback for hybrid automatic repeat request (HARQ).*

43. *An apparatus for receiving data in a communication system, the apparatus comprising:*

a Fourier Transform (FT) block configured to perform an FT operation on a received signal to generate N outputs, wherein a first subset of the N outputs comprises FT pre-coded modulated data symbols and a second subset of the N outputs comprises non-FT pre-coded modulated control symbols;

an inverse FT (IFT) block configured to perform IFT operations on M inputs, wherein M is less than N;

16

a subcarrier demapping block configured to receive the first subset of the N outputs from the FT block and to demap the first subset of outputs to the inputs of the IFT block, wherein the IFT block is further configured to perform an IFT operation on the inputs to recover modulated data symbols; and

a demodulation block configured to demodulate the modulated data symbols.

44. *The apparatus of claim 43, wherein the first subset further comprises FT pre-coded modulated control symbols, wherein the IFT block is further configured to perform an IFT operation on the inputs to recover modulated control symbols, and wherein the demodulation block is further configured to demodulate the modulated control symbols.*

45. *The apparatus of claim 43, wherein the demodulation block is further configured to demodulate the non-FT pre-coded modulated control symbols.*

46. *The apparatus of claim 45, wherein the first subset of the N outputs further comprises a pilot signal, wherein the second subset of the N outputs comprises control information other than the pilot signal, wherein the IFT block is further configured to perform the IFT operation to recover modulated pilot symbols, and wherein the demodulator is further configured to demodulate the modulated pilot symbols.*

47. *The apparatus of claim 43, wherein the non-FT pre-coded modulated control symbols comprise control information, and wherein the control information comprises at least one of a pilot signal, a resource request, a random access, Channel Quality Indicator (CQI) and a feedback for HARQ.*

* * * * *