



US00RE44016E

(19) **United States**
(12) **Reissued Patent**
Remmers

(10) **Patent Number:** **US RE44,016 E**
(45) **Date of Reissued Patent:** **Feb. 19, 2013**

(54) **WALL ANCHOR**
(75) Inventor: **Lee E. Remmers**, Ocala, FL (US)
(73) Assignee: **Clairson, Inc.**, Newark, DE (US)
(21) Appl. No.: **11/014,663**
(22) Filed: **Dec. 16, 2004**

4,210,057 A * 7/1980 Goring et al. 411/37
4,221,154 A 9/1980 McSherry
4,264,047 A 4/1981 Nelson
4,274,324 A 6/1981 Giannuzzi
4,312,614 A 1/1982 Palmer et al.
(Continued)

Related U.S. Patent Documents

Reissue of:
(64) Patent No.: **6,494,653**
Issued: **Dec. 17, 2002**
Appl. No.: **09/835,967**
Filed: **Apr. 17, 2001**

FOREIGN PATENT DOCUMENTS

DE 2847595 * 5/1980 411/62
GB 1000131 8/1965

OTHER PUBLICATIONS

Toggler® Anchor System Product Catalog, www.toggler.com, 6 pages.

(Continued)

Primary Examiner — Roberta Delisle
(74) *Attorney, Agent, or Firm* — Harness, Dickey & Pierce, P.L.C.

(51) **Int. Cl.**
F16B 21/00 (2006.01)
(52) **U.S. Cl.** **411/344**; 411/44; 411/45; 411/57.1;
411/62; 411/63; 411/80.5; 411/340
(58) **Field of Classification Search** 411/344,
411/44, 57.1, 62, 63, 80.5, 80.6
See application file for complete search history.

(57) **ABSTRACT**

The present invention is a wall anchor having a novel finger configuration. This wall anchor has a head and barrel portion with a bore extending therethrough and laterally expandable fingers in general alignment with the bore. Instead of a straight channel, a channel having curved portions separates the fingers. The curved portions of the channel define ramp surfaces that at least partially extend into the path of a securing member created by the bore. Thus, when a securing member, such as a bolt, pin, screw, nail or similar object is inserted into the bore to secure the wall anchor to the wall, the securing member contacts the two ramp surfaces, separating the fingers. As the fingers separate, a portion of the fingers near the ramp surfaces deform such that the ramp surfaces rest on an outer portion of the securing member, thus providing a securing force for connecting the wall anchor to the wall and relieving stress on the area at which the fingers are connected to the barrel.

(56) **References Cited**

U.S. PATENT DOCUMENTS

D48,258 S 12/1915 Pleister
D48,259 S 12/1915 Pleister
D48,260 S 12/1915 Pleister
D48,261 S 12/1915 Pleister
D48,262 S 12/1915 Pleister
D48,263 S 12/1915 Pleister
D48,264 S 12/1915 Pleister
2,033,100 A 3/1936 Kellogg
2,555,420 A 6/1951 Richardson
3,188,905 A 6/1965 Millet
3,413,887 A * 12/1968 Von Wolff et al. 411/62
3,650,173 A 3/1972 Mathe
4,181,061 A 1/1980 McSherry

22 Claims, 5 Drawing Sheets

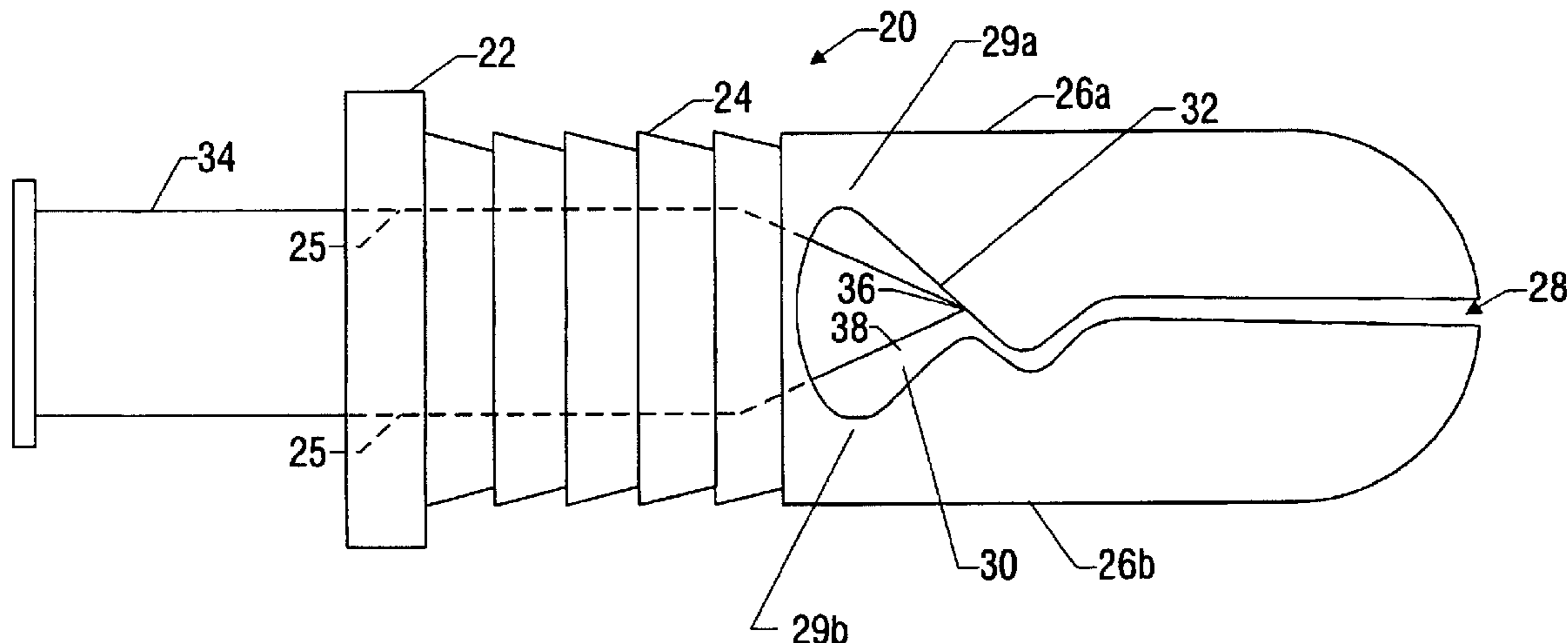

US RE44,016 E

Page 2

U.S. PATENT DOCUMENTS

4,361,099 A	11/1982	Kokenge et al.	5,288,189 A	2/1994	Hepworth
4,518,291 A	5/1985	Lang et al.	5,308,203 A	5/1994	McSherry et al.
4,548,327 A	10/1985	Kilkelly	5,312,215 A	5/1994	Anquetin
4,571,134 A	2/1986	Beglinger et al.	5,380,135 A	1/1995	Anquetin
4,624,376 A	11/1986	Bertram	5,409,336 A	4/1995	Jericevich et al.
4,637,765 A	1/1987	Omata	5,529,449 A	6/1996	McSherry et al.
4,646,998 A	3/1987	Pate	5,533,851 A	7/1996	Remmers
4,662,595 A	5/1987	Camilleri	5,536,121 A	7/1996	McSherry
4,669,936 A	6/1987	Camilleri	5,540,528 A	7/1996	Schmidt et al.
4,693,248 A	9/1987	Faila	5,603,593 A *	2/1997	Fischer et al. 411/55
4,708,552 A	11/1987	Bustos et al.	5,605,238 A	2/1997	Jacobs
4,722,648 A	2/1988	Camilleri	5,704,746 A	1/1998	Leib et al.
4,735,325 A	4/1988	Remmers	5,752,792 A	5/1998	McSherry
4,752,170 A	6/1988	McSherry et al.	5,807,050 A	9/1998	Daler et al.
4,753,405 A	6/1988	Camilleri	5,833,415 A	11/1998	McSherry
4,757,664 A *	7/1988	Freissle 52/509	5,938,385 A	8/1999	Garfield et al.
4,861,206 A	8/1989	Riedel	5,944,295 A	8/1999	McSherry
4,878,790 A	11/1989	McSherry et al.	6,086,035 A	7/2000	Trifilio
D310,623 S	9/1990	Aranibar	6,829,871 B1	12/2004	McSherry et al.
4,993,901 A	2/1991	McSherry et al.	7,143,497 B2 *	12/2006	Panasik et al. 29/525.05
5,028,186 A	7/1991	McSherry	2005/0076602 A1	4/2005	Routhier
D322,555 S	12/1991	Kokenge et al.			
5,161,296 A	11/1992	Garfield et al.			
5,195,856 A	3/1993	McSherry et al.			
5,205,688 A	4/1993	Sundstrom			
5,224,805 A *	7/1993	Moretti et al. 411/30			
5,246,323 A	9/1993	Vernet et al.			
5,286,152 A	2/1994	Anderson			

OTHER PUBLICATIONS

Office Action dated Apr. 29, 2002 for U.S. Appl. No. 09/835,967 (7 pages).

English Translation of Abstract for DE 28 47 595 (1 page).

* cited by examiner

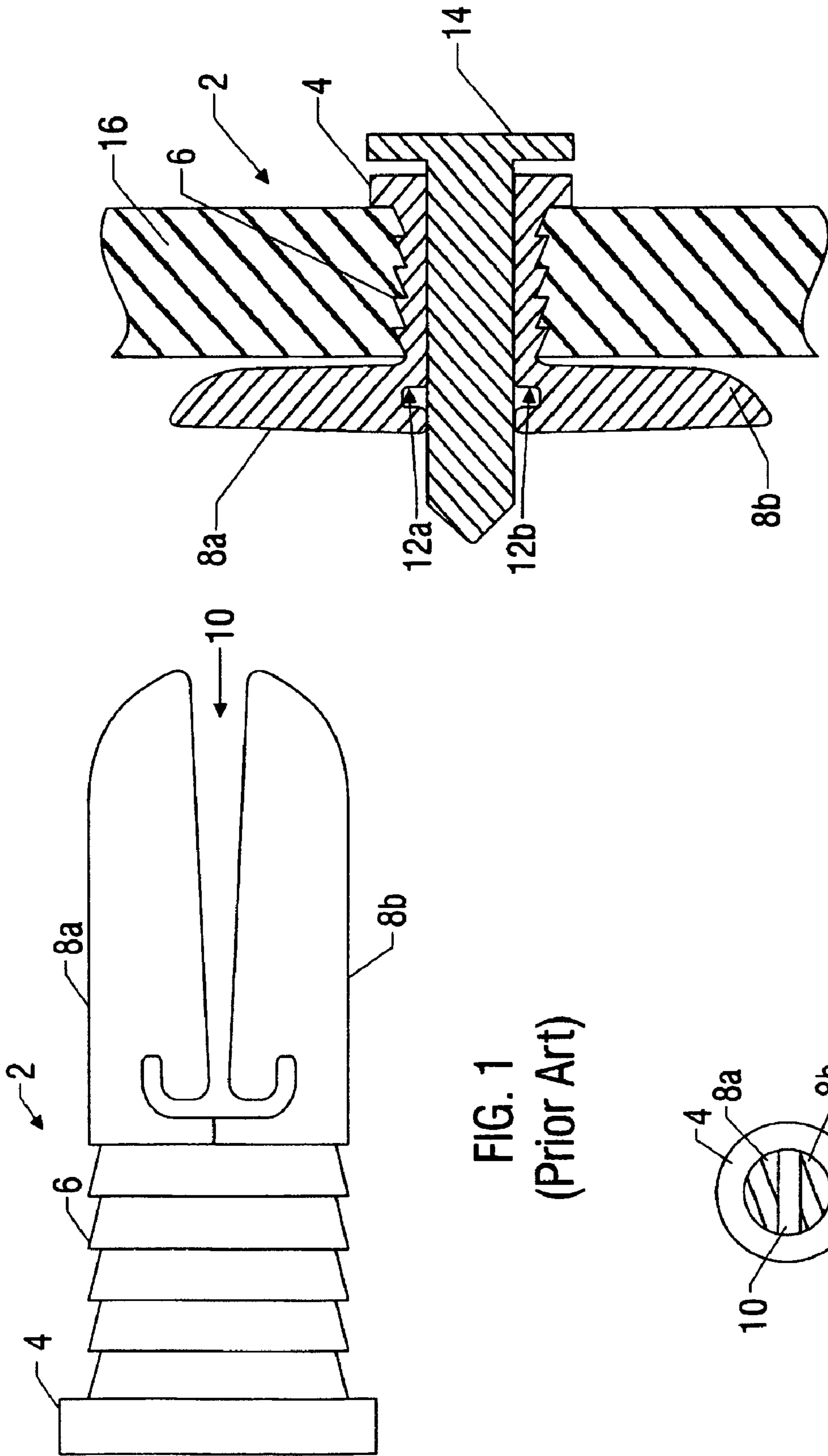

FIG. 1
(Prior Art)

FIG. 2A
(Prior Art)

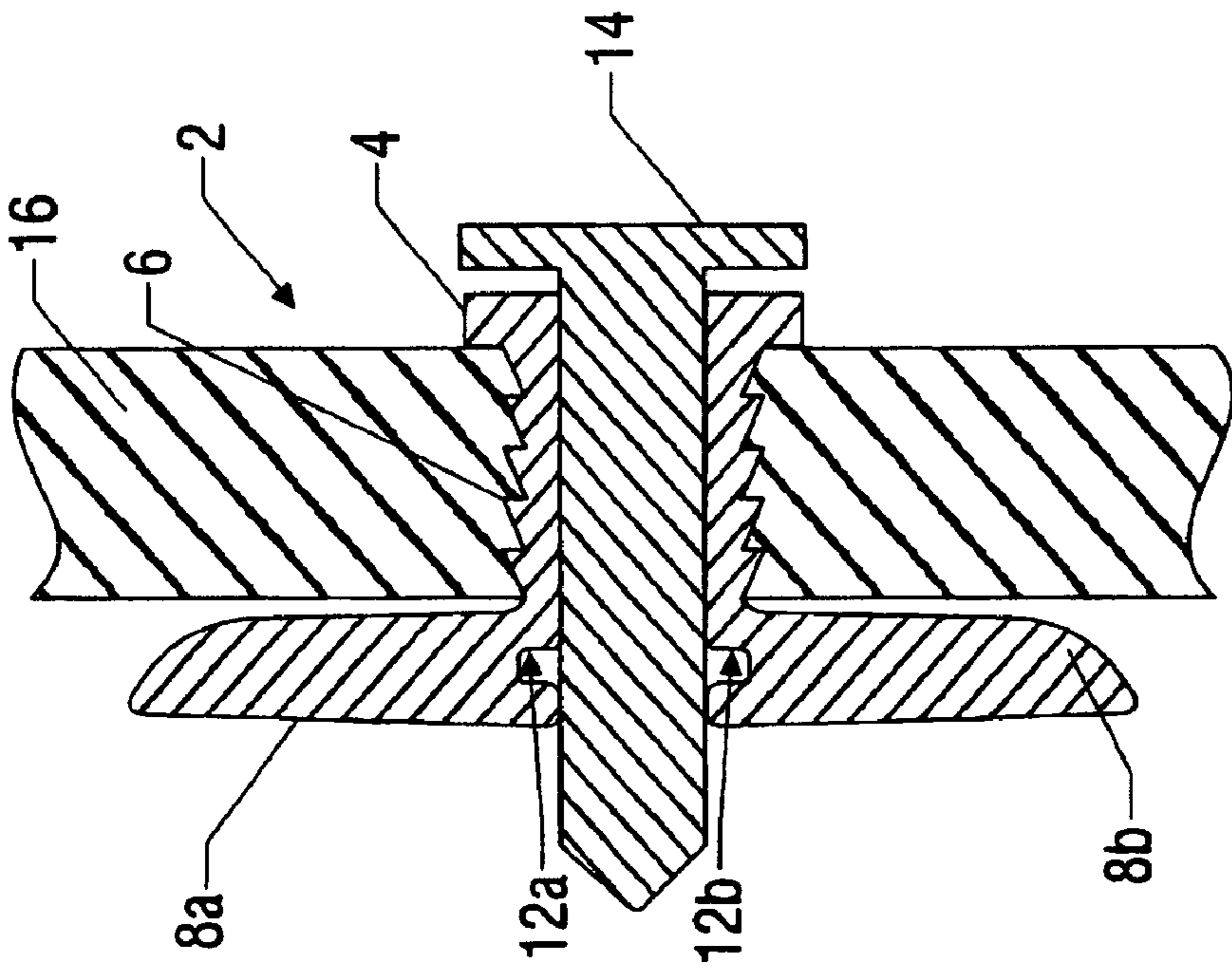

FIG. 2B
(Prior Art)

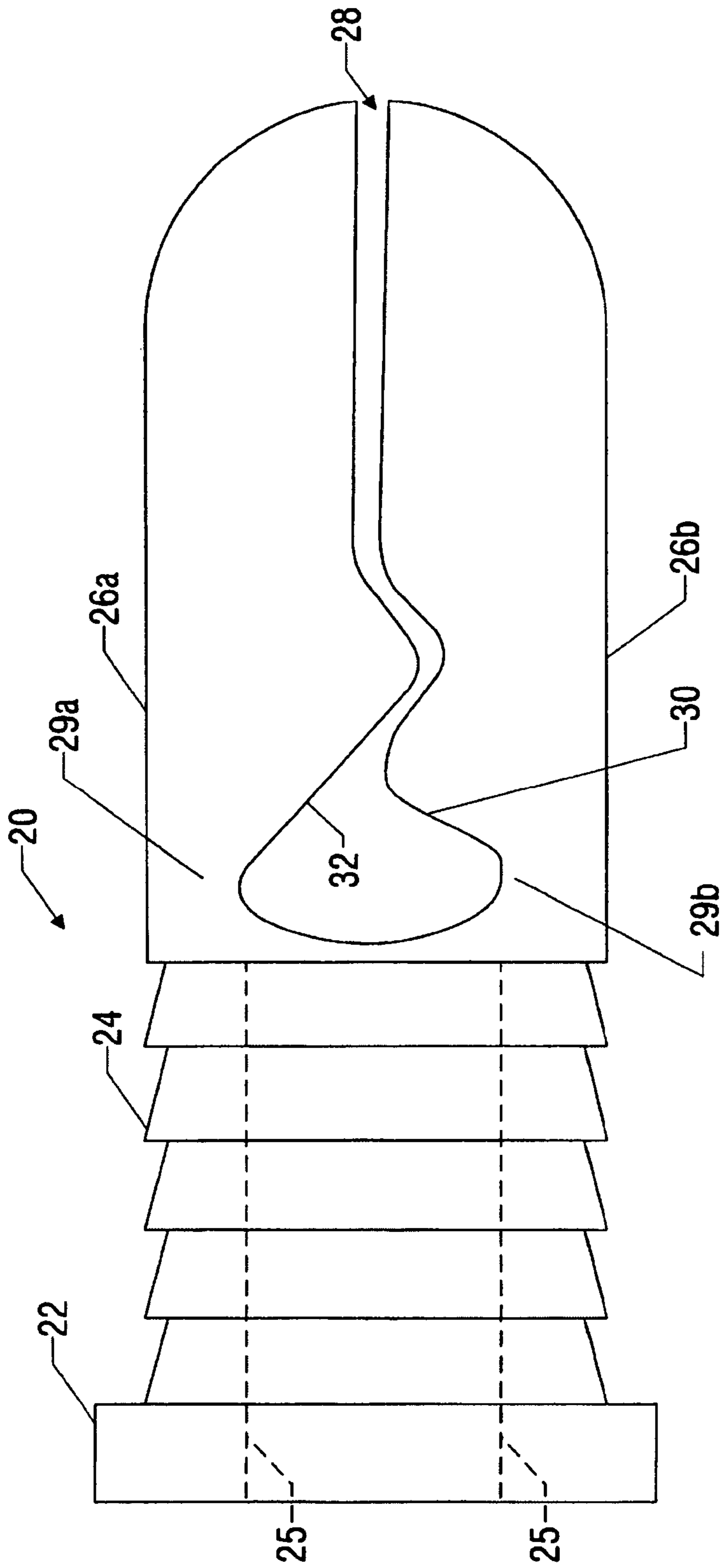

FIG. 3

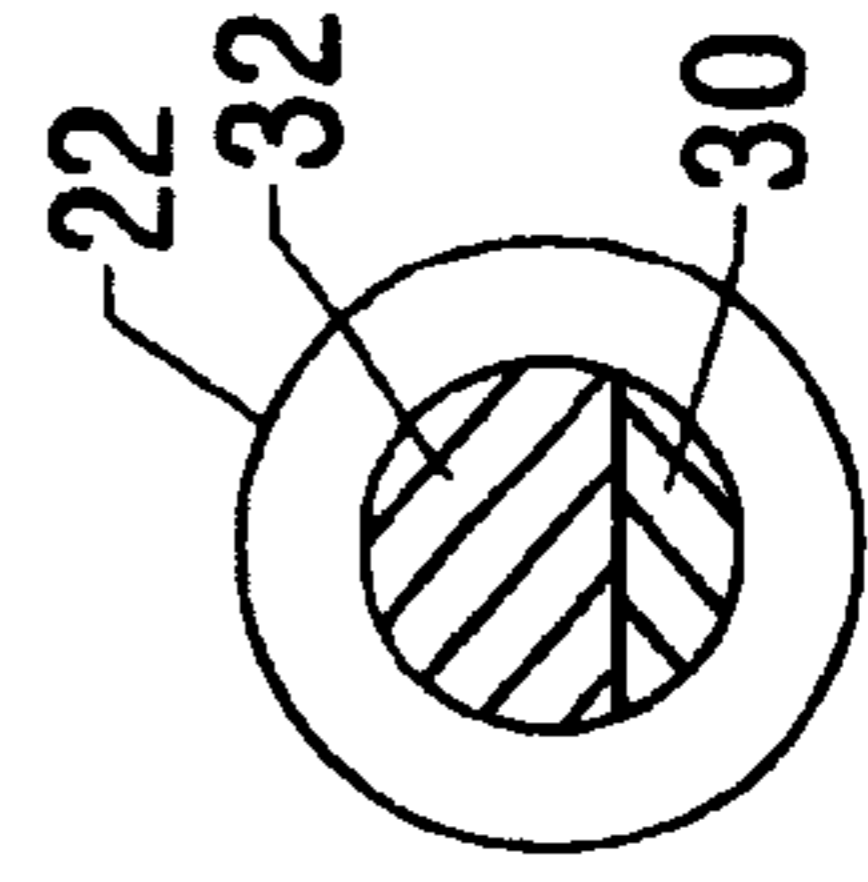

FIG. 4

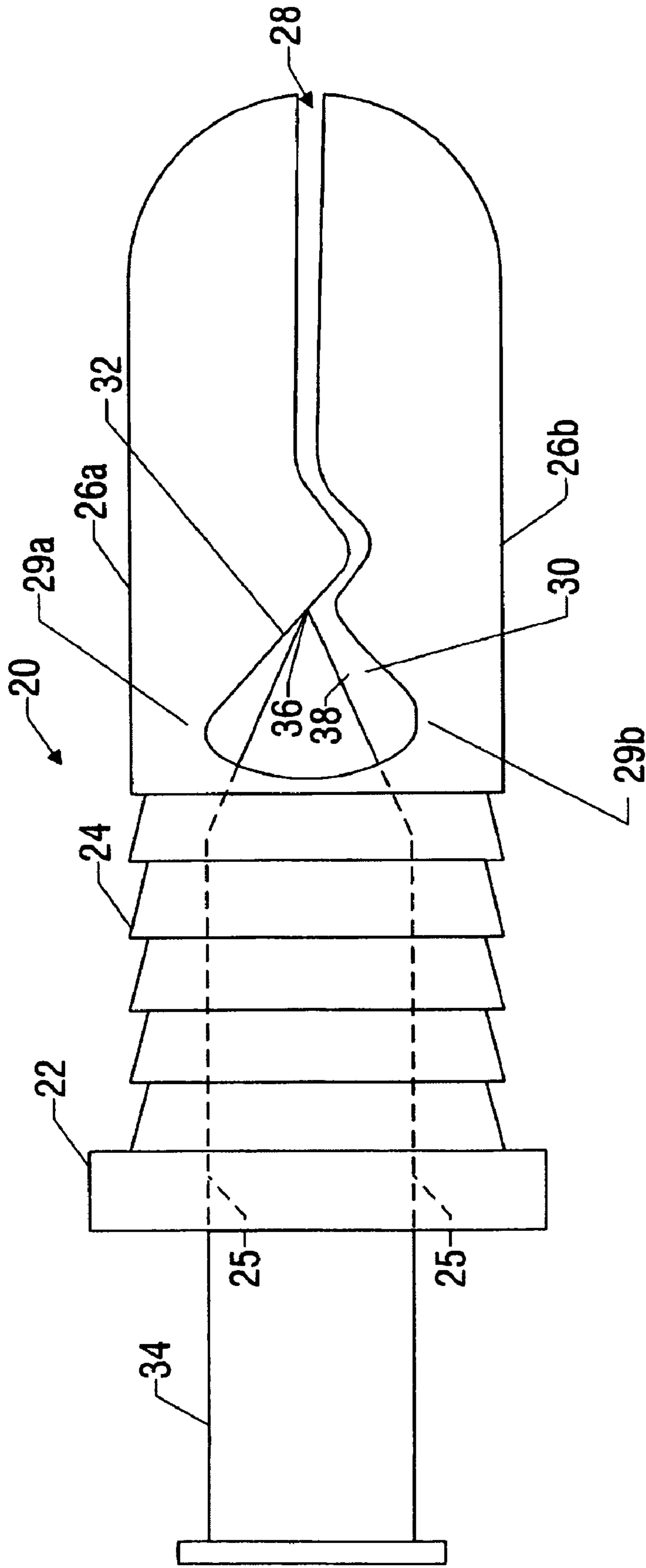

FIG. 5

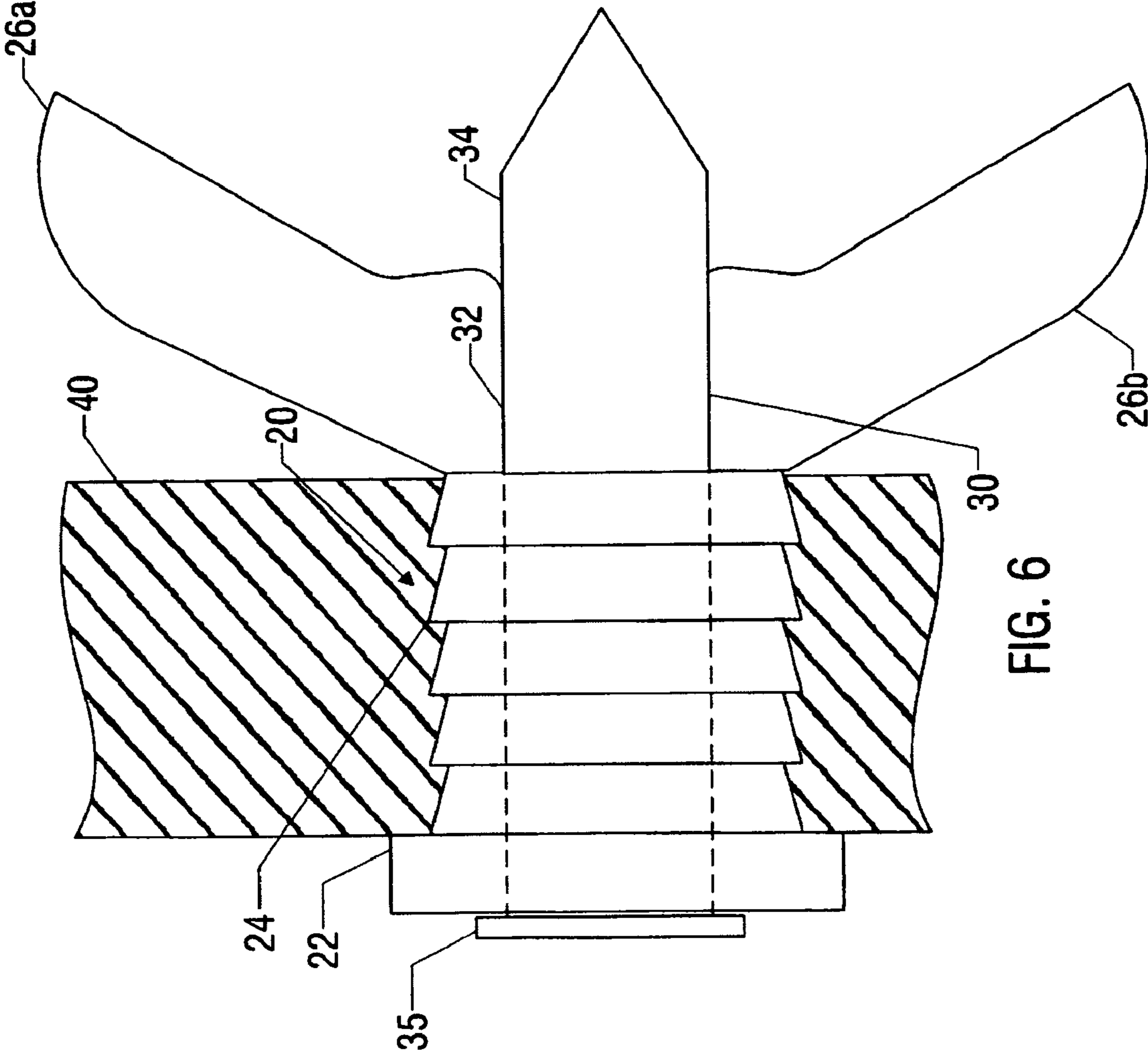

FIG. 6

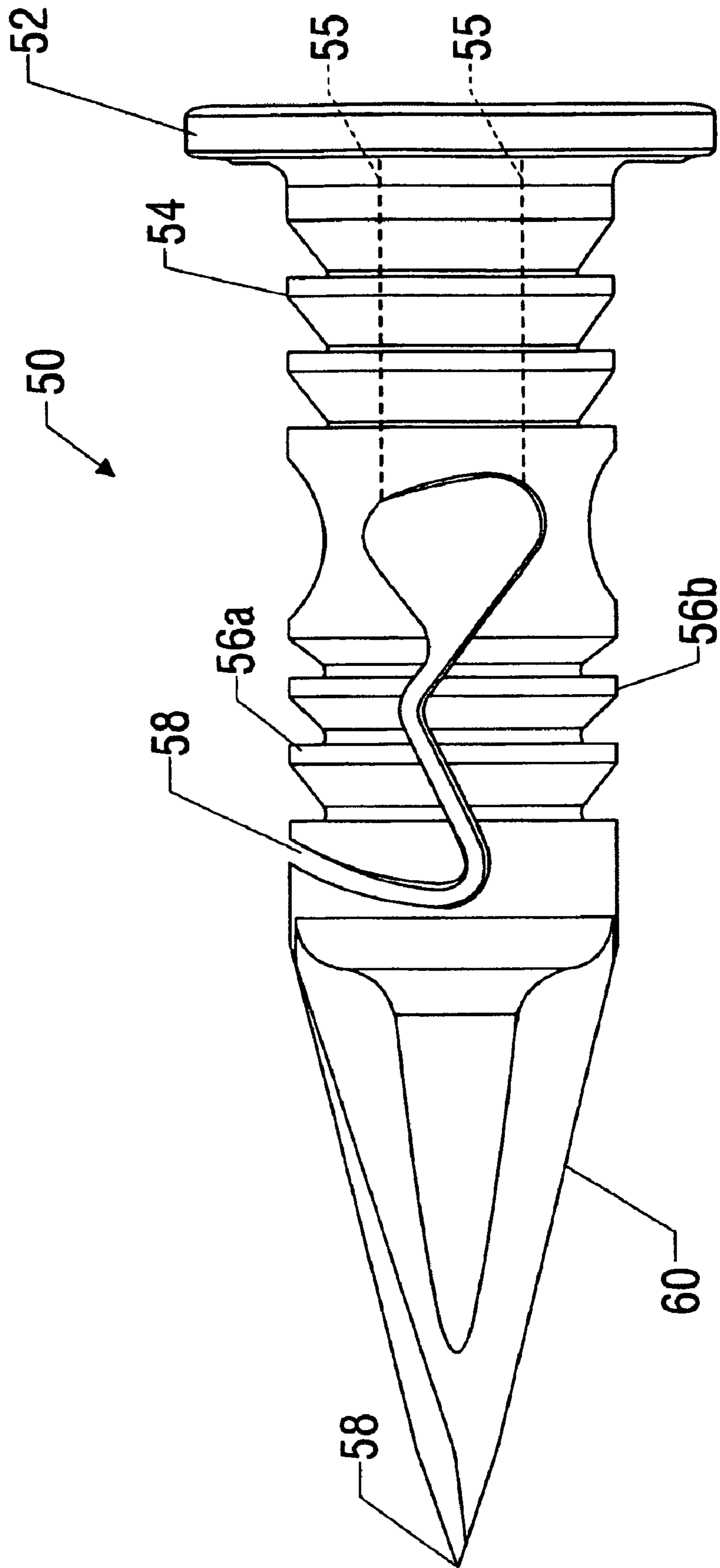

FIG. 7

1

WALL ANCHOR

Matter enclosed in heavy brackets [] appears in the original patent but forms no part of this reissue specification; matter printed in italics indicates the additions made by reissue.

BACKGROUND OF THE INVENTION

In walls formed of plaster boards, sheet rock, plywood and other relatively thin or soft materials, problems can arise when attempting to mount objects to these walls, particularly transverse rods for draperies, drapes, lighting fixtures, picture frames and other objects which impose stress upon these walls. These walls can be incapable of receiving the aforementioned rods, fixtures and frames when held in place by standard screws and bolts. Thus, it has become common practice to use anchoring sockets of some sort in order to secure these objects to a wall. A number of wall anchors are noted in the prior art, particularly U.S. Pat. Nos. 4,646,998; 4,752,170; 5,409,339; 5,533,851; and 6,086,035.

Prior art wall anchors, or back clips as they are otherwise known, such as disclosed in U.S. Pat. No. 4,669,936, teach a back clip having a body portion with a hollow barrel therein and laterally expandable fingers in alignment with the hollow barrel. The fingers extend through a wall and upon receiving a bolt, pin, screw or other securing member through the barrel, the laterally expandable fingers expand against the inside portion of the wall.

Common wall anchors, such as the one taught by U.S. Pat. No. 4,669,936, have a straight channel separating the fingers. This channel is usually narrower than the hollow barrel portion, so that when the securing member is inserted, it expands the fingers, securing the wall anchor to the wall. When these fingers are expanded they necessarily bend or hinge at some point on the finger, usually at a point at or near where each finger is connected to the hollow barrel. This hinge portion of the fingers is thus normally under some amount of stress due to the deformation that takes place in the wall anchor when the bolt, pin or screw is introduced into the wall anchor. Because of this stress, harder, more rigid plastics, the most preferred material of construction for wall anchors, tend to break in this hinge area, particularly when used in cold-weather. Softer plastics are commonly used to avoid this breakage problem, but may correspondingly reduce the strength of the wall anchor.

Referring to FIG. 1, a prior art wall anchor 2 is shown. Wall anchor 2 of FIG. 1 includes a generally flat circular head 4 having a bore therethrough (not shown) for receiving a securing member, such as a bolt, pin, screw, nail or similar object (not shown). Wall anchor 2 also contains a barrel 6 having a bore therethrough (not shown) and a pair of symmetrical fingers 8a and 8b flexibly joined to the barrel 14 at its back end. A generally straight channel 10 separates the two symmetrical fingers 8a and 8b. FIG. 2A shows a view of the prior art wall anchor from the front, and, looking through the bore in head 4, channel 10 is visible between the two symmetrical fingers 8a and 8b.

FIG. 2B shows the prior art wall anchor 2 in its secured position in a wall 16. The bores through the barrel 6 and the head 4 receive a securing member, in this case a mounting pin 14, therethrough. When the mounting pin 14 is inserted into the wall anchor, the pin engages and spreads the fingers 8a and 8b apart. The portions 12a and 12b, where the fingers 8a

2

and 8b attach to the barrel 6, are under a considerable amount of stress due to the deformation that takes place when the fingers are expanded.

It would thus be desirable to develop a wall anchor designed to reduce stress in the hinge portion of the fingers. This type of wall anchor would allow for the use of harder, more rigid plastics, resulting in a stronger anchor less susceptible to breakage.

SUMMARY OF THE INVENTION

A wall anchor has a body portion having a hollow barrel and laterally expandable fingers in general alignment with the hollow barrel. Instead of using a straight channel separating two symmetrical fingers, as is commonly used in prior art wall anchors, an asymmetrical channel is used to provide at least two ramp surfaces, one on each of a plurality of asymmetrical fingers, i.e. none of the fingers are the same shape. The ramp surfaces face the path created by the hollow portion of the barrel. Thus, when a securing member, such as a bolt, pin, screw, nail or other similar object, is inserted into the hollow barrel to secure the wall anchor to the wall, the securing member contacts the two ramp surfaces. As the securing member is pushed through the hollow barrel and into the curved channel, it separates the fingers. As the fingers separate, the ramp surfaces deform under the pressure exerted by the securing member, and then rest on an outer portion of the securing member.

This design thus allows for a redistribution of the stress from a hinge portion of the anchor to the ramp surfaces of the fingers when the fingers are separated. This allows the wall anchor to be manufactured from harder, more rigid materials, thereby improving the strength of the wall anchor and reducing its susceptibility to breaking.

BRIEF DESCRIPTION OF THE DRAWINGS

FIG. 1 is a side view of a prior art wall anchor.

FIG. 2A is a front view of a prior art wall anchor.

FIG. 2B is a side, cross-sectional view of the prior art anchor secured in a wall with its fingers expanded.

FIG. 3 is a side view of one embodiment of the present invention.

FIG. 4 is a front view of one embodiment of the present invention.

FIG. 5 is a view of one embodiment of the present invention as a securing member interacts with the ramp surfaces of the present invention.

FIG. 6 is a view of one embodiment of the present invention with its fingers expanded.

FIG. 7 is a side view of an embodiment of the present invention having a self-drilling feature.

DESCRIPTION OF ILLUSTRATIVE EMBODIMENTS

FIG. 3 displays one embodiment of the novel wall anchor 20 of the present invention. Wall anchor 20 of the illustrated embodiment of the present invention includes a head 22 preferably having a bore 23 therethrough (shown in FIG. 4) for receiving a securing member (not shown) such as a bolt, pin, screw, nail or similar object. The bore can be of any acceptable shape to receive a securing member, but is preferably at least partially circular. In one example, the bore can have a flattened portion so as to better secure the securing member, as described in U.S. Pat. No. 5,553,851. The head can also be of any configuration, including having a hook or

other member integrally formed or attached thereto in order to hang an item (for example a wire shelf) to a wall.

Wall anchor **20** also contains a barrel **24** having a bore therethrough (shown with the bore defined by dashed lines **25**) and a plurality of preferably resilient fingers, here shown in a preferred embodiment of two asymmetrical fingers **26a** and **26b**. The barrel **24** is attached at one end to the head **22**, and the fingers are flexibly joined to the barrel **24** at the barrel's other end. The diameter of the bore through barrel **24** is preferably substantially the same size as the bore in the circular head **22**. The barrel **24** is also preferably notched, as shown, so that the notches can cut into or otherwise engage the wall material when the wall anchor **20** is being pulled from the wall, so as to prevent slippage.

Channel **28** separates the asymmetrical fingers **26a** and **26b**. Unlike known wall anchors, a portion of channel **28** does not run down the centerline between the fingers. Instead, a portion of channel **28** provides ramp faces **30** and **32** that face the bore of barrel **24** and extend at least partially into the path created by the bore. This novel design allows for easier installation of a securing member in that after a securing member is passed through the bores of the head **22** and the barrel **24**, it contacts the ramps, thereby expanding the fingers. Viewing the wall anchor from the front and looking through the bore **25**, as in FIG. **4**, it can be seen how ramp faces **30** and **32** extend into the path created by the bore **25**. Channel **28** is not visible between the fingers **26a** and **26b**, because in combination the ramp faces **30** and **32** on the two fingers cover the path created by the bore **25**.

In the embodiment shown in FIG. **5**, the securing member first contacts one ramp and begins expanding its respective finger, and then contacts the other ramp, expanding its respective finger. By beginning the expansion of one finger at a time in the preferred embodiment, the securing member is made easier to push or screw into the wall anchor **20**. Furthermore, the ramps are preferably made out of a deformable material, such as plastic, such that after being engaged by the securing member, the ramps **30** and **32** on fingers **26b** and **26a** respectively, can deform and flatten out, ending up in continuous contact with the shaft of the securing member.

The extent of such deformation will likely depend on the thickness of the wall or other support to which it is attached. If the fingers are completely free from the wall (as shown in FIG. **6**) less deformation will take place than if all or a portion of the fingers was positioned inside of the thickness of the wall. This deformation of the ramps redistributes some of the stress loading on the anchor from the hinge areas **29a** and **29b** where the fingers **26a** and **26b** connect to the barrel **24**, to the ramp faces **30** and **32** that are in contact with the securing member. This helps to reduce the wall anchor's chances of breaking at the hinge area, allowing for the use of stronger, more rigid plastics, and thus increasing the strength and the life of the wall anchor.

FIG. **5** shows an example of the engagement of a securing member **34**, in this case shown as a pin, with the ramp faces **30** and **32** just prior to the expansion of the fingers **26a** and **26b**. In the embodiment of FIG. **5**, when the securing member **34** is inserted into the bore, point **36** engages flat ramp face **32**. As the securing member **34** proceeds forward, finger **26a** is expanded and is forced upwardly. As the securing member **34** continues forward, taper **38** will contact ramp **30**, and finger **26b** will expand and be forced downward. Of course, the ramps can be configured in any manner such that deformation of the ramps occurs, thereby reducing stress on the hinge portion.

FIG. **6** illustrates the securing member **34** completely inserted into an embodiment of the wall anchor **20** as shown

in narrow wall **40**. The securing member **35** is pushed forward until a head **35** of the securing member **34**, which preferably has a larger diameter than the bore through the head **22** of the wall anchor **20**, contacts head **22** of the wall anchor **20**. After being expanded, the ramps **30** and **32** on fingers **26b** and **26a**, respectively, deform (slightly, in the embodiment shown), ending up in continuous contact with the shaft of the securing member **34**. Expanded fingers **26a** and **26b** thus secure the wall anchor **20** to the wall **40**. As discussed above, wall anchor **20** can also be similarly mounted in walls that are thicker than the barrel **24**. The ramps **30** and **32** of FIG. **6**, however, would be more deformed by the securing member **34** and could even 'flatten' to the sides of the fingers, thus creating a securing force on the inside of the wall **40**.

The wall anchors of the present invention are preferably of unitary construction and made of a suitable resilient plastic or polymer material, such as polypropylene. ABS is the most preferred plastic material of construction. ABS is stronger, stiffer and tougher than high impact polystyrene and is also superior to it in its resistance to high temperatures and chemicals. This stronger, stiffer, tougher nature of ABS makes it desirable to improve the strength characteristics of the wall anchor. Stiffer plastics can have tendency to break when under stress, particularly in colder climates. The novel design of the present invention, however, redistributes the stresses away from the hinge areas where the fingers connect to the barrel. Thus, harder, stiffer ABS can be used without the worry that the wall anchor will break at the hinge area.

The use of harder, stiffer plastics also allows the wall anchor to be designed so as to screw itself into a wall or other support structure. Commonly, a hole is first drilled into the support structure of relatively the same or slightly smaller diameter of the barrel of the wall anchor. The wall anchor is inserted therein, and then the securing member inserted into the wall anchor to secure it to the support structure. In contrast, in one embodiment of the present invention the wall anchor can be designed with a self drilling point to cut its own hole.

Referring now to FIG. **7**, another embodiment of the current invention, wall anchor **50**, is shown with head **52** and barrel **54**, each having bore therethrough (shown by dashed lines **55**) for receiving a securing member (not shown). Wall anchor **50** also contains a plurality (preferably a pair) of fingers **56a** and **56b** flexibly joined to the barrel **54**. The diameter of the bore through barrel **54** is substantially the same size as the bore in the head **52**.

Channel **58** separates fingers **56a** and **56b** much like the embodiment of the wall anchor shown in FIG. **3**. In this embodiment, though, the channel divides the fingers **56a** and **56b** so that one finger, finger **56b** as shown, can have a screw tip **60** attached to it. Screw tip **60** has a self-drilling point **58** that cuts its own hole in the wall or support member. Head **52** of wall anchor **50** may have a means for receiving a screwdriver therein for screwing the self-drilling wall anchor **50** into a wall or support member. For example, head **52** can have slots therein for insertion of the tip of a screwdriver. Wall anchor **50** can also be configured to be driven into a wall with a hammer, mallet or similar device.

The wall anchors of the present invention are preferably manufactured as a single piece with all the features incorporated therein. The wall anchor of the present invention can also be attached to or manufactured as a single piece with a functional unit of some sort. For instance, U.S. Pat. No. 4,735,325 discloses a support clip requiring a means for attachment to a support structure. The wall anchor of the present invention can be used as those means, and could be made in unitary construction with the support clip. Generally,

5

functional units in need of a wall anchor of the present invention will be hooks, clips, rings, support structures such as shelving, and other apparatuses that are attached to a wall or other support structure.

While the structures of the present invention have been described in terms of preferred embodiments, it will be apparent to those of skill in the art that variations may be applied to what has been described herein without departing from the concept and scope of the invention. All such similar substitutes and modifications apparent to those skilled in the art are deemed to be within the scope and concept of the invention as it is set out in the following claims.

What is claimed is:

[1. A wall anchor comprising:

a barrel having a bore extending longitudinally there-through and a plurality of fingers, at least 2 of which are asymmetrical, said fingers attached to the barrel;

wherein a non-linear channel separates the fingers, the channel defining resiliently-deformable ramp surfaces on the fingers, each ramp surface facing the bore of the barrel and at least partially extending into the path created by said bore;

wherein when a securing member is inserted into the bore, the securing member contacts the ramp faces so as to provide spreading force to the fingers, after which the ramp faces remain in contact with the securing member; and

wherein at least one finger further comprises a self-drilling portion so that the wall anchor can be inserted into a wall or support member without pre-drilling a hole into said wall or support member.]

[2. The wall anchor of claim 1 wherein the self-drilling portion of the one finger comprises a screw tip.]

[3. The wall anchor of claim 1 further comprising a head having a bore extending longitudinally therethrough that is aligned with the bore of the barrel.]

[4. The wall anchor of claim 3 wherein the head comprises a means for engaging a screwdriver.]

[5. The wall anchor of claim 1 further comprising a securing member able to be inserted into the bore.]

[6. The wall anchor of claim 1 wherein the barrel is notched.]

[7. The wall anchor of claim 1 wherein the internal bore is at least partially circular in cross-section.]

[8. The wall anchor of claim 1 wherein the wall anchor is of unitary construction.]

[9. The wall anchor of claim 1 wherein the wall anchor is made of a resilient plastic material.]

[10. The wall anchor of claim 9 wherein the wall anchor is made of ABS plastic.]

[11. The wall anchor of claim 7 wherein the bore has a flattened portion on one side.]

12. A wall anchor barrel, adapted to be inserted into an opening in a wall and expanded with a securing member, the barrel having a longitudinal passageway extending partly therethrough, the barrel including a plurality of hinged asymmetrical fingers separated by a non-linear channel having an enlarged proximal end portion adjacent hinge portions of the fingers, at least two of the fingers having a ramp surface generally facing the passageway, the non-linear channel also including a distal end portion adjacent ends of the fingers, and a medial portion immediately adjacent the ramp surfaces between and spaced apart from the distal end portion and the enlarged proximal end portion such that the ramp surfaces are between the medial portion and the enlarged proximal end portion, each of the distal end portion and the medial portion being smaller than the enlarged proximal end portion,

6

tion, the enlarged proximal end portion and distal end portion being respectively located proximally and distally relative to the ramp surfaces on different sides thereof, the enlarged proximal end being located between the ramp surfaces and the longitudinal passageway and being at least as large as or larger than the longitudinal passageway; wherein the ramp surfaces are oriented so that an end of the securing member inserted through the passageway passes one of the ramp surfaces and engages the other one of the ramp surfaces.

13. The wall anchor barrel of claim 12 wherein the ramp surfaces on the fingers are staggered in distance from an end of the passageway.

14. The wall anchor barrel of claim 12 wherein the enlarged proximal end portion is configured so as to increase flexibility of the hinge portions of the fingers.

15. The wall anchor barrel of claim 12 wherein the ramp surfaces are resiliently deformable.

16. The wall anchor barrel of claim 12 wherein the hinge portions of the fingers cooperate to define the enlarged proximal end portion of the non-linear channel therebetween.

17. The wall anchor barrel of claim 12 wherein the barrel is configured such that the securing member inserted through the passageway contacts the ramp surfaces to provide a spreading force to the fingers after which the ramp surfaces remain in contact with the securing member.

18. The wall anchor barrel of claim 12 wherein the ramp surfaces at least partially define at least a portion of the enlarged proximal end portion of the non-linear channel.

19. The wall anchor barrel of claim 12 wherein the angle defined between a proximal one of the ramp surfaces and a longitudinal centerline of the passageway is different than the angle defined between the distal one of the ramp surfaces and the longitudinal centerline of the passageway.

20. The wall anchor barrel of claim 19 wherein a proximal one of the ramp surfaces is at a steeper angle relative to the longitudinal centerline of the passageway than the distal one of the ramp surfaces.

21. The wall anchor barrel of claim 12 wherein the enlarged proximal end portion comprises a bulbous opening defining the ramp surfaces.

22. The wall anchor barrel of claim 12, wherein each of the fingers having a ramp surface is the same length.

23. The wall anchor barrel of claim 12, wherein at least one of the ramp surfaces extends across a longitudinal centerline of the passageway.

24. A wall anchor barrel, adapted to be inserted into an opening in a wall and expanded with a securing member, the barrel having a longitudinal passageway extending partly therethrough, the barrel including a plurality of hinged asymmetrical fingers separated by a non-linear channel having an enlarged proximal end portion adjacent hinge portions of the fingers, at least two of the fingers having a ramp surface generally facing the passageway, the non-linear channel also including a distal end portion adjacent ends of the fingers, and a medial portion immediately adjacent the ramp surfaces between and spaced apart from the distal end portion and the enlarged proximal end portion such that the ramp surfaces are between the medial portion and the enlarged proximal end portion, each of the distal end portion and the medial portion being smaller than the enlarged proximal end portion, the enlarged proximal end portion and distal end portion being respectively located proximally and distally relative to the ramp surfaces on different sides thereof, the enlarged proximal end being located between the ramp surfaces and the longitudinal passageway and being at least as large as or larger than the longitudinal passageway; wherein the ramp surface on a first one of the fingers projects less than half way

across an end of the passageway so that the securing member inserted through the passageway contacts the ramp surface on a second one of the fingers before contacting the ramp surface on the first one of the fingers.

25. The wall anchor barrel of claim 24 wherein the ramp surfaces are oriented so that an end of the securing member inserted through the passageway passes one of the ramp surfaces and engages the other one of the ramp surfaces.

26. A wall anchor barrel, adapted to be inserted into an opening in a wall and expanded with a securing member, the barrel having a longitudinal passageway extending partly therethrough, the barrel including first and second asymmetrical fingers separated by a non-linear channel, the first and second fingers including respective first and second ramp surfaces generally facing the passageway, wherein a first angle defined between the first ramp surface and a longitudinal centerline of the passageway is different than a second angle defined between the second ramp surface and the longitudinal centerline of the passageway, wherein at least one of the ramp surfaces extends across the longitudinal centerline of the passageway, wherein the non-linear channel includes an enlarged proximal end portion located between the ramp surfaces and the longitudinal passageway; wherein the first and second ramp surfaces are oriented so that an end of the securing member inserted through the passageway passes the first ramp surface and engages the second ramp surface.

27. The wall anchor barrel of claim 26 wherein the first ramp surface is at a steeper angle relative to the longitudinal centerline of the passageway than the second ramp surface.

28. The wall anchor barrel of claim 26 wherein the first and second ramp surfaces are staggered in distance from an end of the passageway.

29. The wall anchor barrel of claim 26 wherein the first and second ramp surfaces are resiliently deformable.

30. The wall anchor barrel of claim 26 wherein the non-linear channel includes a bulbous opening defining the first and second ramp surfaces.

31. The wall anchor barrel of claim 26 wherein the barrel is configured such that the securing member inserted through the passageway contacts the first and second ramp surfaces to provide a spreading force to the first and second fingers after which the first and second ramp surfaces remain in contact with the securing member.

32. A wall anchor barrel, adapted to be inserted into an opening in a wall and expanded with a securing member, the barrel having a longitudinal passageway extending partly therethrough, the barrel including first and second asymmetrical fingers separated by a non-linear channel, the first and second fingers including respective first and second ramp surfaces generally facing the passageway, wherein a first angle defined between the first ramp surface and a longitudinal centerline of the passageway is different than a second angle defined between the second ramp surface and the longitudinal centerline of the passageway, wherein at least one of the ramp surfaces extends across the longitudinal centerline of the passageway, wherein the non-linear channel includes an enlarged proximal end portion located between the ramp surfaces and the longitudinal passageway; wherein the first ramp surface projects less than half way across an end of the passageway so that the securing member inserted through the passageway contacts the second ramp surface before contacting the first ramp surface.

33. The wall anchor barrel of claim 32 wherein the first and second ramp surfaces are oriented so that an end of the securing member inserted through the passageway passes the first ramp surface and engages the second ramp surface.

* * * * *