

US00RE43956E

(19) **United States**  
(12) **Reissued Patent**  
**King et al.**

(10) **Patent Number:** **US RE43,956 E**  
(45) **Date of Reissued Patent:** **Feb. 5, 2013**

(54) **ENERGY STORAGE SYSTEM FOR ELECTRIC OR HYBRID VEHICLE**

5,418,444 A \* 5/1995 Cook et al. .... 320/125  
5,488,283 A \* 1/1996 Dougherty et al. .... 307/10.1  
5,589,743 A 12/1996 King  
5,710,699 A 1/1998 King et al.  
5,713,425 A 2/1998 Buschhaus et al.  
5,722,502 A 3/1998 Kubo

(75) Inventors: **Robert Dean King**, Schenectady, NY (US); **Timothy Gerard Richter**, Wynantskill, NY (US); **Lembit Salasoo**, Schenectady, NY (US)

(Continued)

(73) Assignee: **General Electric Company**, Schenectady, NY (US)

**FOREIGN PATENT DOCUMENTS**

DE 10317093 11/2004  
JP 04-271209 A 9/1992

(Continued)

(21) Appl. No.: **13/025,102**

(22) Filed: **Feb. 10, 2011**

**OTHER PUBLICATIONS**

JP Office Action dated Nov. 15, 2011 from corresponding JP Application No. 2008-549486 with unofficial English translation.

(Continued)

**Related U.S. Patent Documents**

Reissue of:

(64) Patent No.: **7,489,048**  
Issued: **Feb. 10, 2009**  
Appl. No.: **11/327,954**  
Filed: **Jan. 9, 2006**

(51) **Int. Cl.**  
**H02P 1/00** (2006.01)

(52) **U.S. Cl.** ..... **307/10.1; 307/52; 320/104; 318/139**

(58) **Field of Classification Search** ..... 307/71,  
307/9.1, 10.1, 116, 52; 320/117, 104; 180/65.225;  
318/139

See application file for complete search history.

*Primary Examiner* — Daniel Cavallari

(74) *Attorney, Agent, or Firm* — Ziolkowski Patent Solutions Group, SC; Jean K. Testa

(57) **ABSTRACT**

A battery load leveling system for an electrically powered system in which a battery is subject to intermittent high current loading, the system including a first battery, a second battery, and a load coupled to the batteries. The system includes a passive storage device, a unidirectional conducting apparatus coupled in series electrical circuit with the passive storage device and poled to conduct current from the passive storage device to the load, the series electrical circuit coupled in parallel with the battery such that the passive storage device provides current to the load when the battery terminal voltage is less than voltage on the passive storage device, and a battery switching circuit that connects the first and second batteries in either a lower voltage parallel arrangement or a higher voltage series arrangement.

(56) **References Cited**

**U.S. PATENT DOCUMENTS**

4,004,208 A 1/1977 Tamminen  
4,139,812 A \* 2/1979 Huggins ..... 320/117  
4,412,137 A \* 10/1983 Hansen et al. .... 307/10.6  
4,533,011 A 8/1985 Heidemeyer et al.  
4,862,009 A 8/1989 King  
4,926,104 A 5/1990 King et al.  
5,168,975 A 12/1992 Bernhardt et al.  
5,345,154 A 9/1994 King  
5,373,195 A 12/1994 De Doncker et al.

**56 Claims, 8 Drawing Sheets**

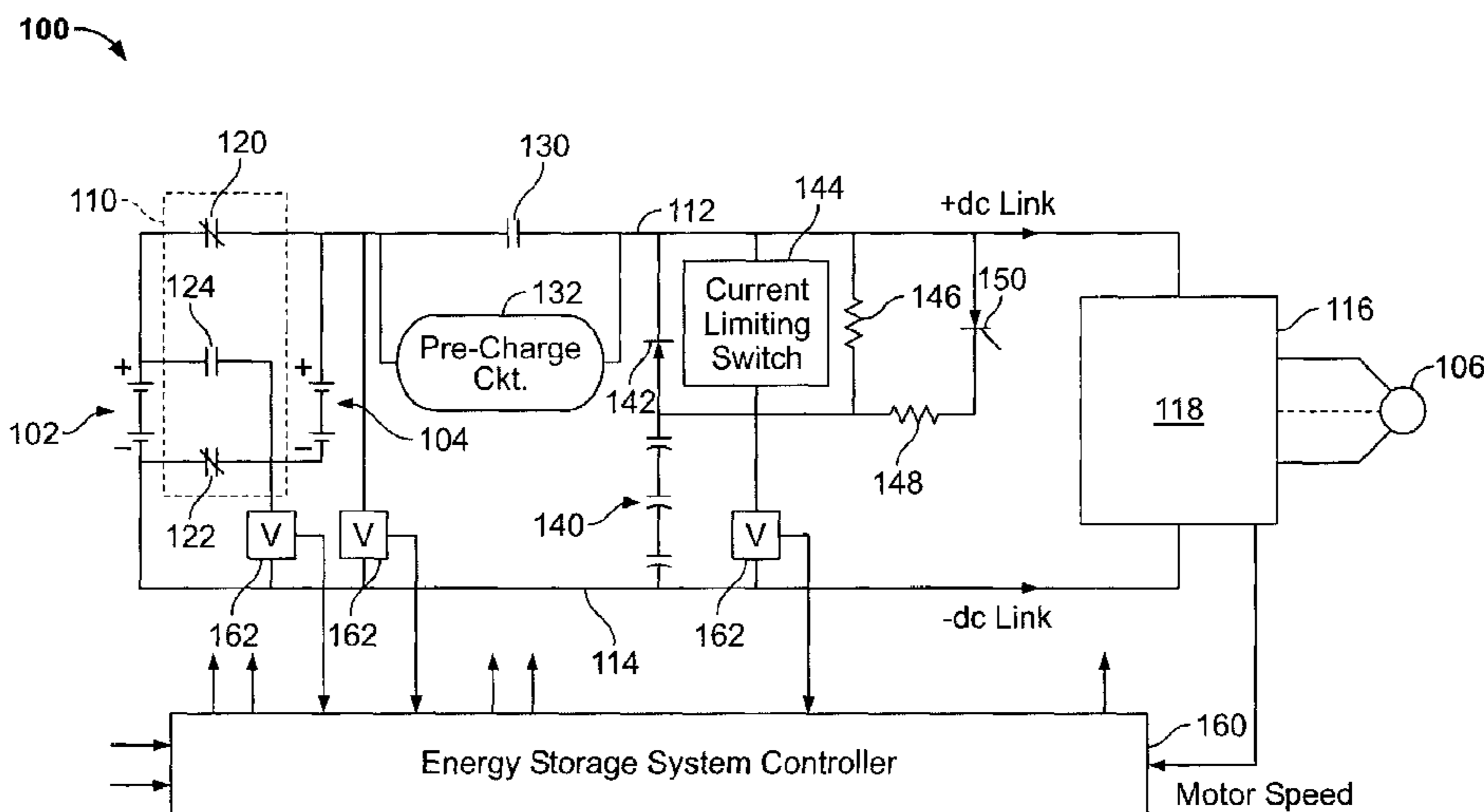

# US RE43,956 E

Page 2

## U.S. PATENT DOCUMENTS

5,723,956 A 3/1998 King et al.  
5,903,449 A 5/1999 Garrigan et al.  
6,170,587 B1 1/2001 Bullock  
6,186,255 B1 2/2001 Shimasaki et al.  
6,227,997 B1 5/2001 Fujisawa et al.  
6,258,006 B1 7/2001 Hanyu et al.  
6,319,168 B1 11/2001 Morris et al.  
6,323,608 B1 \* 11/2001 Ozawa ..... 318/139  
6,331,365 B1 \* 12/2001 King ..... 429/9  
6,332,257 B1 12/2001 Reed, Jr. et al.  
6,342,775 B1 \* 1/2002 Sleder, Sr. .... 320/116  
6,360,834 B1 3/2002 Gauthier  
6,373,152 B1 \* 4/2002 Wang et al. .... 307/150  
6,401,850 B1 6/2002 Bowen  
6,441,581 B1 8/2002 King et al.  
6,478,705 B1 11/2002 Holmes et al.  
6,481,517 B1 11/2002 Kobayashi et al.  
6,486,568 B1 11/2002 King et al.  
6,497,974 B2 \* 12/2002 Fuglevand ..... 429/22  
6,507,128 B2 1/2003 King et al.  
6,533,692 B1 3/2003 Bowen  
6,533,693 B2 3/2003 Bowen et al.  
6,569,055 B2 5/2003 Urasawa et al.  
6,583,523 B1 \* 6/2003 Bhate ..... 307/86  
6,592,484 B1 7/2003 Tsai et al.  
6,603,215 B2 8/2003 Kuang et al.  
6,604,591 B2 8/2003 Bowen et al.  
6,624,535 B2 \* 9/2003 Morrow ..... 307/71

6,645,105 B2 11/2003 Kima  
6,650,091 B1 \* 11/2003 Shiue et al. .... 320/166  
6,679,799 B2 1/2004 Bowen  
6,729,423 B2 5/2004 Kobayashi et al.  
6,737,822 B2 5/2004 King  
6,784,563 B2 8/2004 Nada  
6,817,432 B2 11/2004 Kitada et al.  
6,837,816 B2 1/2005 Tsai et al.  
6,915,220 B2 7/2005 Cardinal et al.  
6,930,404 B1 \* 8/2005 Gale et al. .... 290/40 C  
7,109,686 B2 \* 9/2006 Schulte et al. .... 320/167  
7,352,084 B2 \* 4/2008 Hall et al. .... 307/104  
7,723,954 B2 \* 5/2010 Frucht ..... 320/117  
2004/0251880 A1 \* 12/2004 O'Brien ..... 320/166  
2006/0127704 A1 \* 6/2006 Raiser ..... 429/9  
2006/0133007 A1 \* 6/2006 Shiue et al. .... 361/301.2  
2006/0164034 A1 \* 7/2006 Hanyu et al. .... 320/104

## FOREIGN PATENT DOCUMENTS

JP 05-236608 A 9/1993  
JP 11-252711 A 9/1999  
JP 2004-282800 A 10/2004  
WO WO2004/102768 11/2004

## OTHER PUBLICATIONS

PCT/US2006/048133 dated Jul. 31, 2007.

\* cited by examiner

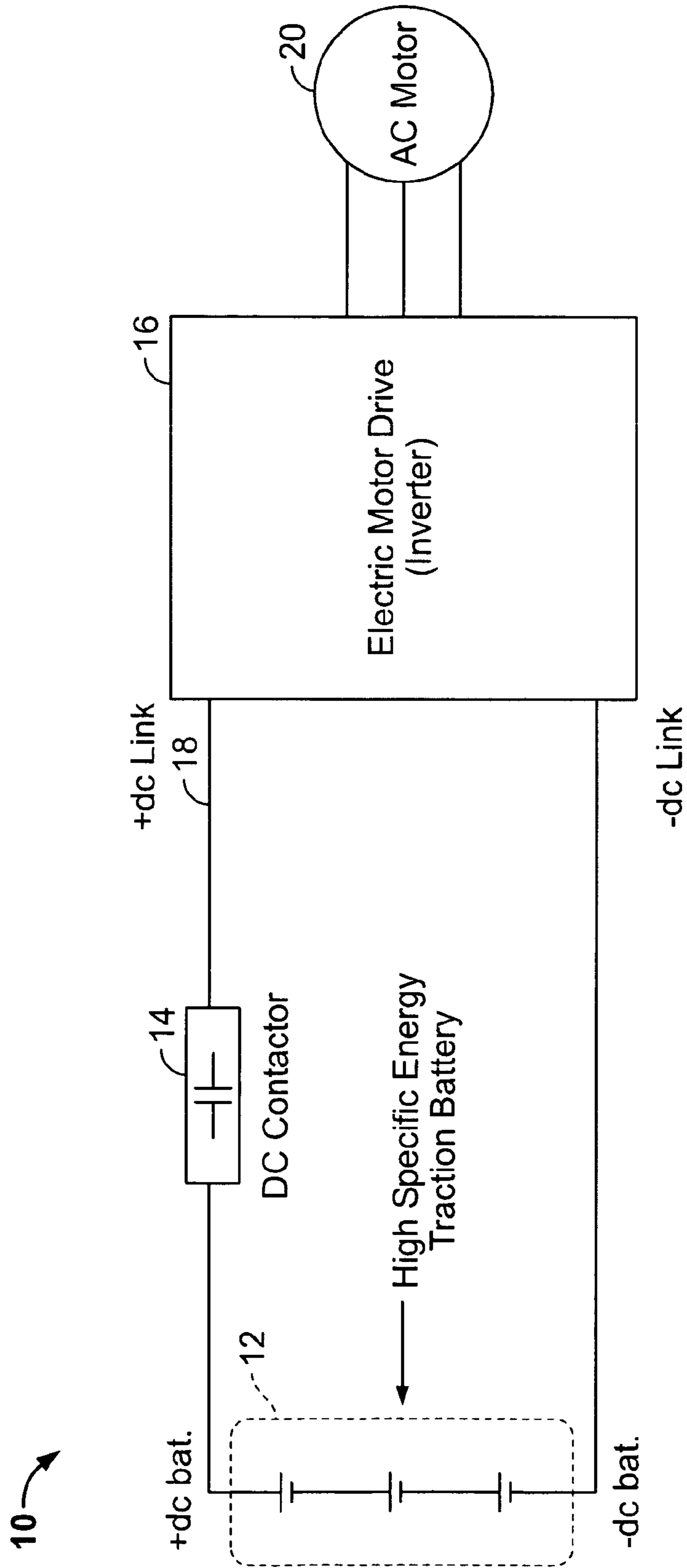
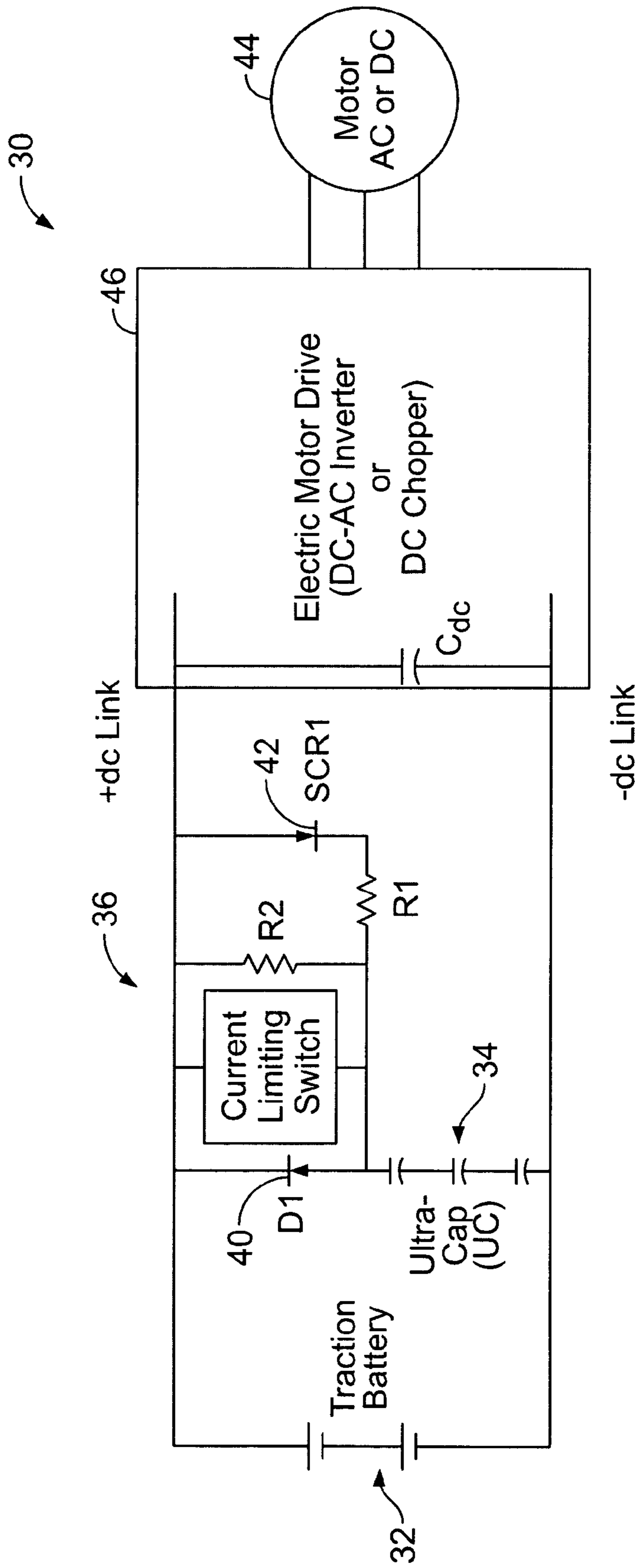

FIG. 1  
(Prior Art)



**FIG. 2**  
**(Prior Art)**

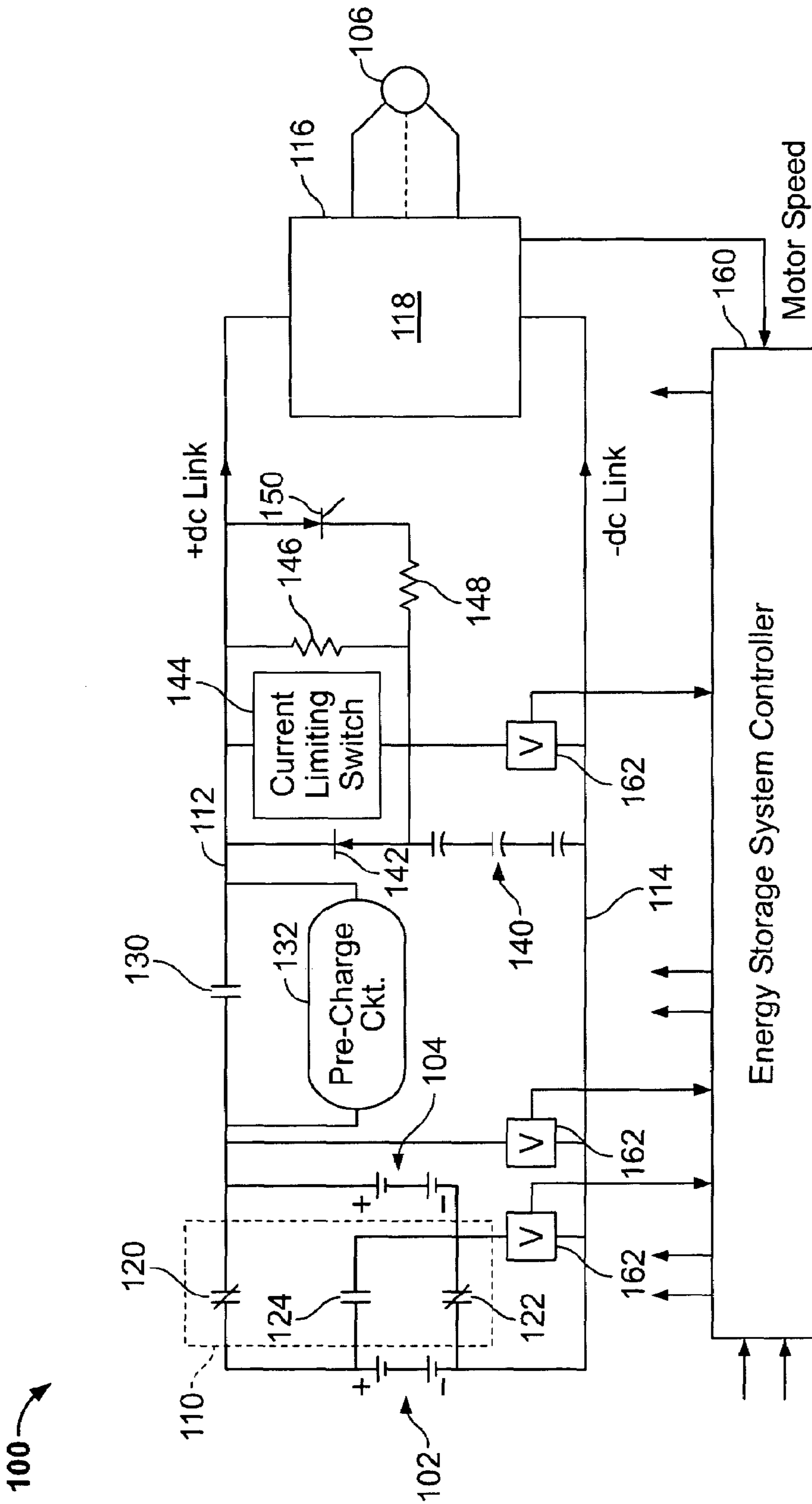

FIG. 3

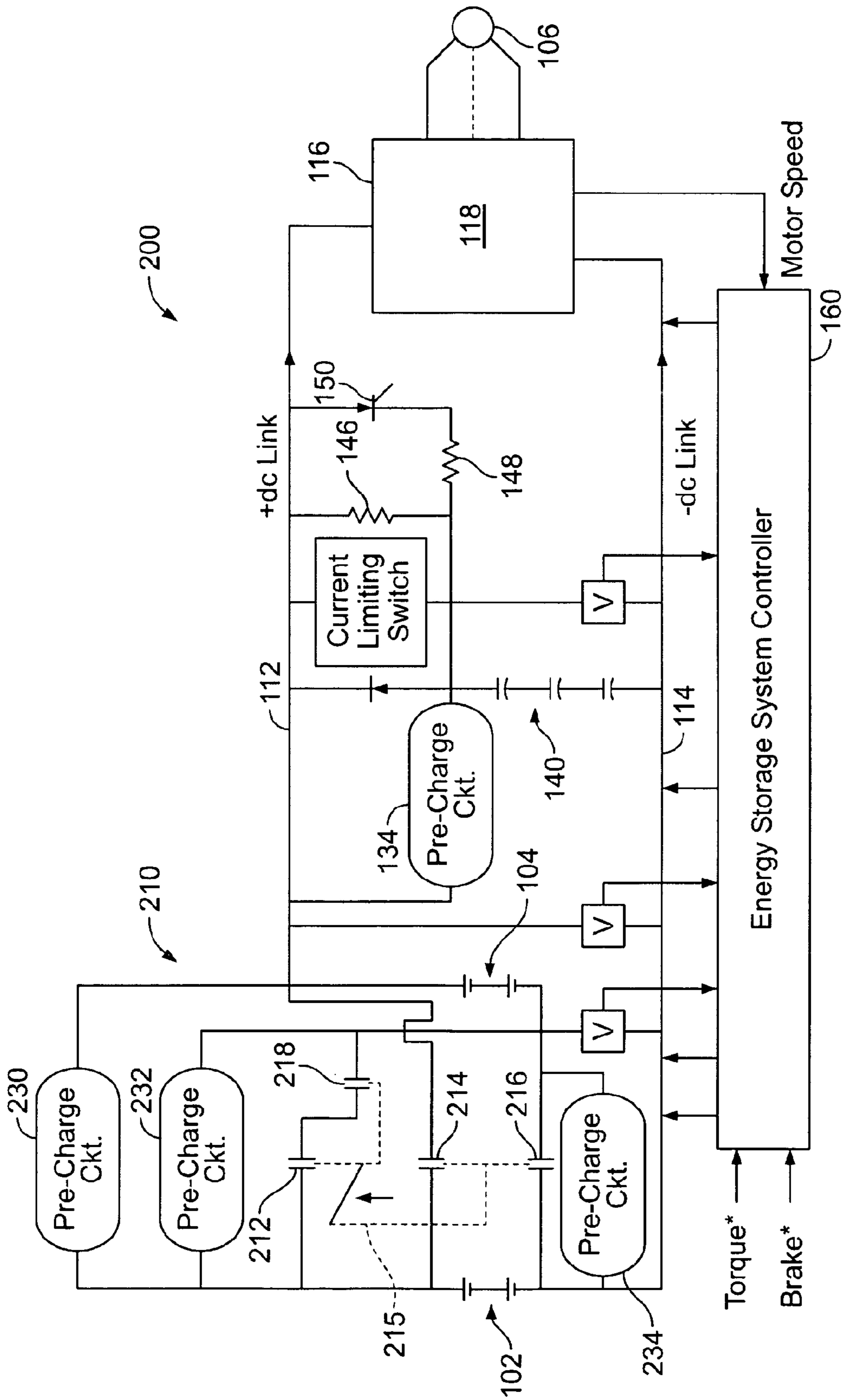

FIG. 4

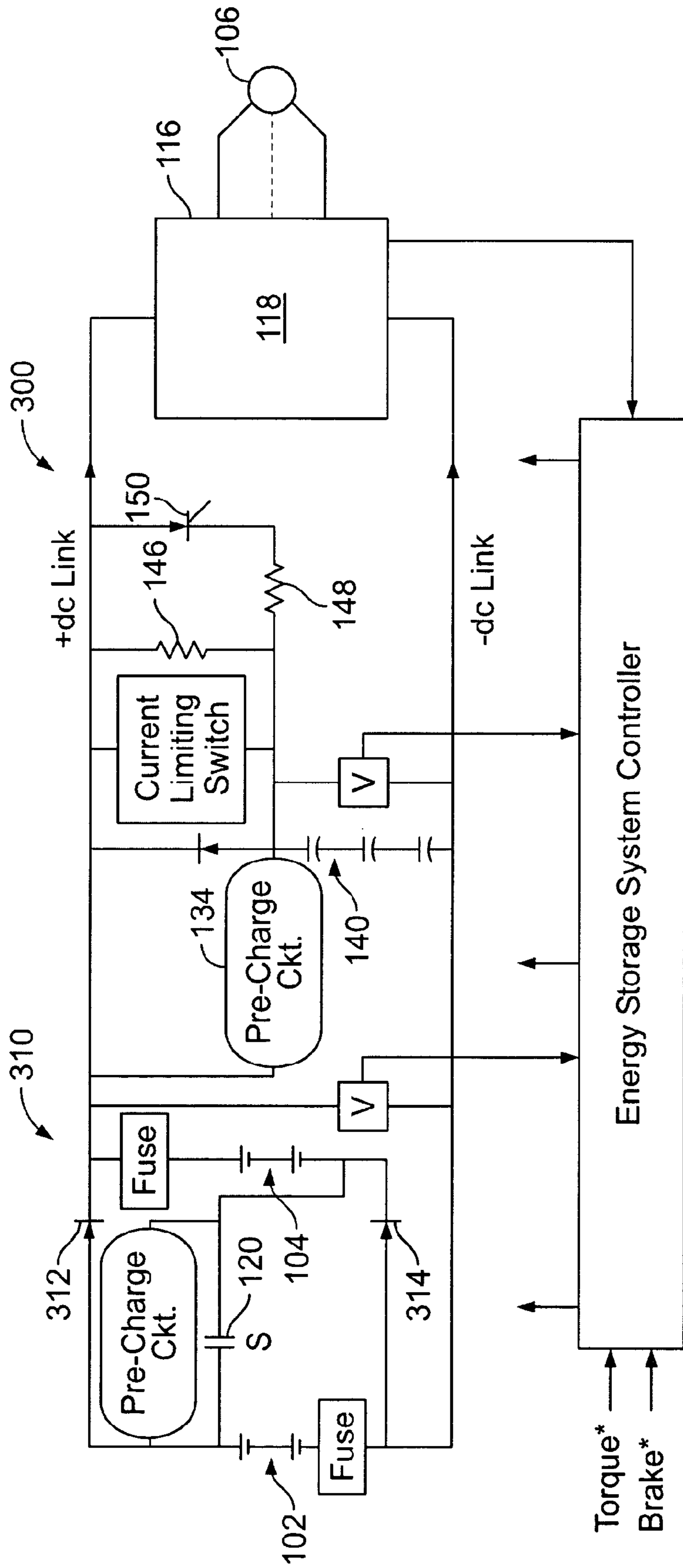

FIG. 5

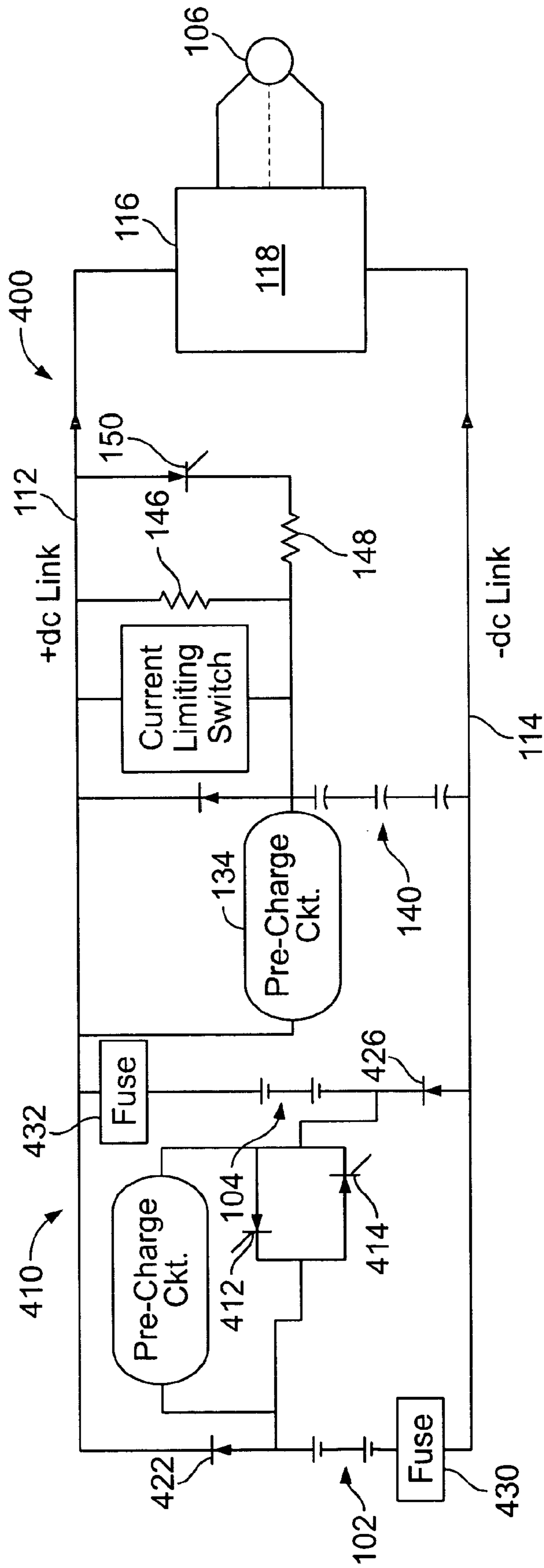

FIG. 6



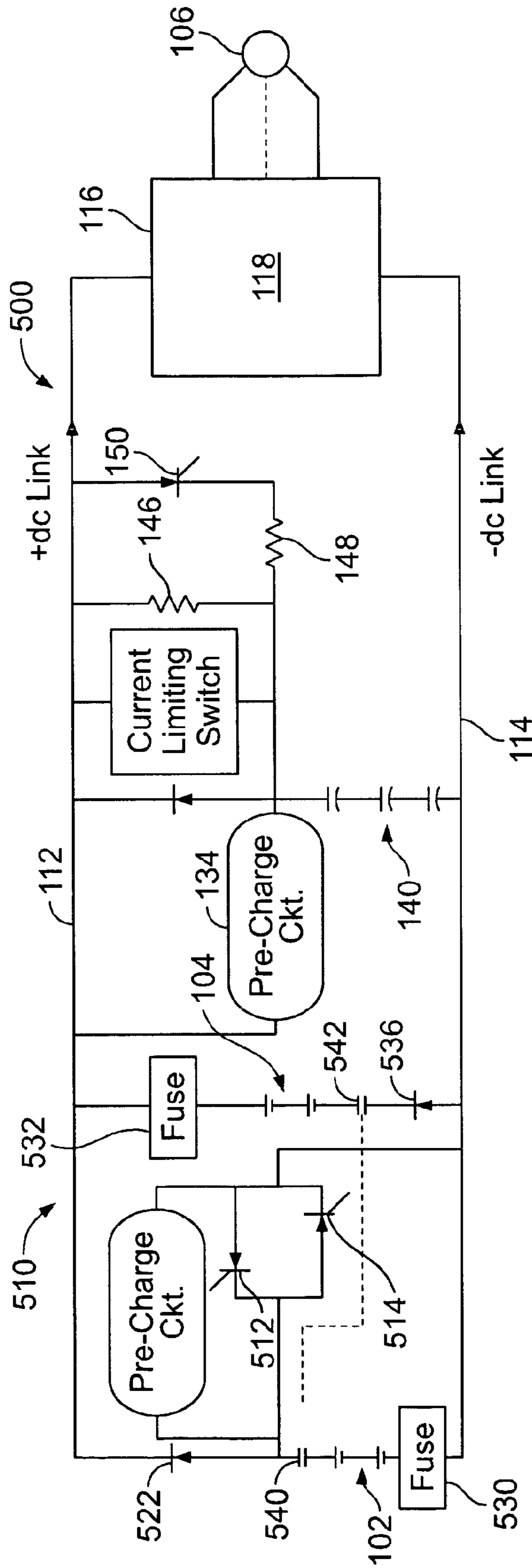

FIG. 7

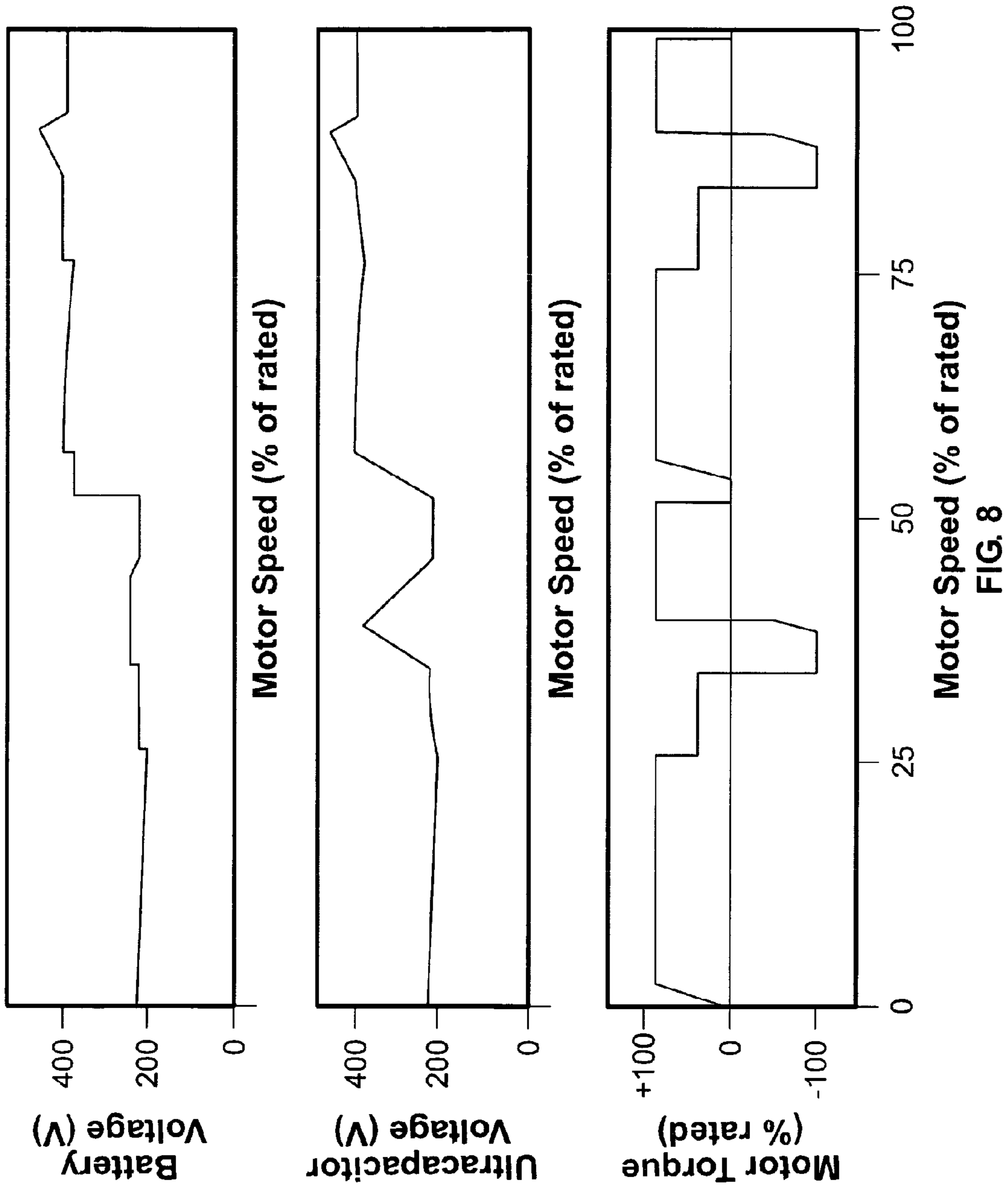

FIG. 8

1

## ENERGY STORAGE SYSTEM FOR ELECTRIC OR HYBRID VEHICLE

**Matter enclosed in heavy brackets [ ] appears in the original patent but forms no part of this reissue specification; matter printed in italics indicates the additions made by reissue.**

### BACKGROUND OF THE INVENTION

This invention relates generally to electric drive systems and, more particularly, to a battery load leveling system that may be utilized with a hybrid or an electric vehicle.

At least one known vehicle includes batteries, typically lead-acid batteries, to provide electric power for vehicle propulsion. For example, FIG. 1 is a prior art vehicle that includes a conventional alternating current (AC) electric propulsion system 10 that is used in electric propelled and also hybrid-electric vehicles. The electric propulsion system includes at least one energy storage unit such as a lead acid battery 12, and a direct current (DC) contactor 14 to electrically disconnect the energy storage unit 12 from a traction inverter 16 via a DC link 18. Specifically, the battery 12 is connected to a DC link which connects to a frequency controlled inverter such as traction DC-AC inverter 16 for controlling power to an AC motor 20.

In the operation of the vehicle, the battery is often called upon to deliver short bursts of power at high current levels, typically during acceleration of the vehicle or while operating the vehicle up a steep grade, for example. When high current is drawn from conventional batteries, battery terminal voltage drops. Such voltage reduction can interfere with proper operation of the vehicle or reduce efficiency of the switching devices in the power control circuit since the control circuit must also be designed to operate at high efficiency at full battery voltage, i.e., when the vehicle is drawing nominal current in a constant speed mode.

One method for reducing the effect of high current requirements on electric drive system batteries is to use an auxiliary passive energy storage device coupled to the DC link to provide additional power during high current situations. One implementation of this method is shown in the prior art FIG. 2. Specifically, FIG. 2 illustrates an energy storage system 30 that includes a traction battery 32 and an ultracapacitor 34, and a relatively low-cost ultracapacitor electronic interface 36 that allows the ultracapacitor 34 to share power with the traction battery 32 during vehicle acceleration and other high power demands while climbing steep grades.

During operation, when the known vehicle is operated during a lower power cruise condition, a diode 40 allows the ultracapacitor voltage to remain at a slightly higher voltage than the battery voltage. Immediately after the high power acceleration is complete, the required current from the energy storage system substantially decreases and the battery voltage increases to the nominal battery voltage or possibly higher voltages, while the ultracapacitor remains at approximately the voltage immediately after the acceleration. Moreover, when the vehicle is decelerating, a silicon-controlled rectifier 42 is gated and the regenerative energy from the electric motor 44 and associated traction drive 46 initially charges the ultracapacitor 34 until the voltage increases to a point where the diode 40 conducts, at which point both the ultracapacitor 34 and battery 32 are partially recharged. As such, the known energy storage system functions quite well and also provides an efficient and low-cost interface between the ultracapacitor and the traction battery in low speed electric vehicles, includ-

2

ing golf cars and small utility vehicles. However, during operation, the amount of energy stored in the ultracapacitor 34 is limited by the square of the voltage difference between the maximum battery voltage plus the voltage drop across the diode 40, and the minimum battery voltage plus the voltage drop across the diode 40.

As a result, known energy storage systems are less effective for providing relatively high power levels over an extended period of time while the vehicle is either accelerating under heavy loads and/or climbing steep grades. Moreover, known energy systems include an electronic interface that may be less effective in matching the ultracapacitor output voltage with the voltage level required for the traction drive with acceptable efficiency and at a reasonable cost.

### BRIEF DESCRIPTION OF THE INVENTION

In one aspect, a battery load leveling system for an electrically powered system in which a battery is subject to intermittent high current loading is provided. The system includes a first battery, a second battery, and a load coupled to the batteries. The system also includes a passive storage device, a unidirectional conducting apparatus coupled in series electrical circuit with the passive storage device and poled to conduct current from the passive storage device to the load, the series electrical circuit coupled in parallel with the battery such that the passive storage device provides current to the load when the battery terminal voltage is less than voltage on the passive storage device, and a battery switching circuit that connects the first and second batteries in either a lower voltage parallel arrangement or a higher voltage series arrangement.

In another aspect, an electric vehicle is provided. The electric vehicle includes a first battery, a second battery, a load coupled to the first and second batteries; the first and second batteries configured to provide the propulsive force for moving the vehicle, and a battery load leveling system. The battery load leveling system includes a passive storage device, a unidirectional conducting apparatus coupled in series electrical circuit with the passive storage device and poled to conduct current from the passive storage device to the load, the series electrical circuit coupled in parallel with at least one of the first and second batteries such that the passive storage device provides current to the load when the battery terminal voltage of at least one of the first and second batteries is less than voltage on the passive storage device, and a battery switching circuit that connects the first and second batteries in either a lower voltage parallel arrangement or a higher voltage series arrangement.

In a further aspect, a hybrid vehicle is provided. The hybrid vehicle includes a first battery, a second battery, a load coupled to the first and second batteries; the first and second batteries configured to provide the propulsive force for moving the vehicle, and a battery load leveling system. The battery load leveling system includes a passive storage device, a unidirectional conducting apparatus coupled in series electrical circuit with the passive storage device and poled to conduct current from the passive storage device to the load, the series electrical circuit coupled in parallel with at least one of the first and second batteries such that the passive storage device provides current to the load when the battery terminal voltage of at least one of the first and second batteries is less than voltage on the passive storage device, and a battery switching circuit that connects the first and second batteries in either a lower voltage parallel arrangement or a higher voltage series arrangement.

In a further aspect, a method of assembling a battery load leveling system for an electrically powered system in which a battery is subject to intermittent high current loading is provided. The system includes a first battery, a second battery, and a load coupled to the first and second batteries. The method includes coupling a unidirectional conducting apparatus in a series electrical circuit with a passive storage device such that the unidirectional conducting apparatus is poled to conduct current from the passive storage device to a load, coupling the series electrical circuit in parallel with the first and second batteries such that said passive storage device provides current to the load when the battery terminal voltage is less than voltage on the passive storage device, and utilizing a battery switching circuit to the first and second batteries in either a lower voltage parallel arrangement or a higher voltage series arrangement.

#### BRIEF DESCRIPTION OF THE DRAWINGS

FIG. 1 is prior art electric propulsion system;

FIG. 2 is a prior art energy storage system;

FIG. 3 is a battery load leveling system including an exemplary battery switching circuit;

FIG. 4 is an exemplary battery switching circuit which may be used with the battery load leveling system shown in FIG. 3;

FIG. 5 is an exemplary battery switching circuit which may be used with the battery load leveling system shown in FIG. 3;

FIG. 6 is an exemplary battery switching circuit which may be used with the battery load leveling system shown in FIG. 3;

FIG. 7 is an exemplary battery switching circuit which may be used with the battery load leveling system shown in FIG. 3; and

FIG. 8 is graphical illustration of the system shown in FIG. 3 during operation.

#### DETAILED DESCRIPTION OF THE INVENTION

FIG. 3 illustrates a battery load leveling system 100. The battery load leveling system 100 includes a first battery 102 and a second battery 104 that are utilized to supply power to a load 106. Load 106 may be an alternating current (AC) or direct current (DC) load such as an electric traction motor for powering electric vehicles. Battery load leveling system 100 also includes a battery switching circuit 110 that includes a plurality of contactors that are operable to connect the first and second batteries 102 and 104, respectively, in either a lower voltage parallel or a higher voltage series arrangement.

Battery switching circuit 110 enables the positive and negative terminals of first battery 102 and second battery 104 to be connected to respective ones of a positive bus 112 and negative bus 114. Positive and negative buses 112 and 114, also referred to herein as the positive and negative DC links, couple batteries 102 and 104 to a power electronics circuit 116 which may include a switching regulator 118 such as a DC-to-AC inverter for supplying alternating current to an AC load or AC motor, or a DC chopper or pulse width modulation circuit (not shown) for providing direct current to a DC load or DC motor.

More specifically, battery switching circuit 110 includes a first contactor 120 that is coupled between the positive terminal of first battery 102 and the positive bus 112, a second contactor 122 that is coupled between the negative terminal of the first battery 102 and the negative terminal of the second battery 104, and a third contactor 124 that is coupled between the positive terminal of the first battery 102 and the negative terminal of the second battery 104.

To operate battery load leveling system 100 in a lower voltage parallel arrangement, contactors 120 and 122 are closed and contactor 124 is opened such that batteries 102 and 104 are electrically coupled in a parallel arrangement to buses 112 and 114, respectively. Optionally, to operate battery load leveling system 100 in a higher voltage series arrangement, contactors 120 and 122 are opened and contactor 124 is closed such that batteries 102 and 104 are electrically coupled in a series arrangement to buses 112 and 114, respectively.

Battery load leveling system 100 also includes a main contactor 130 that is coupled in series between the outputs of batteries 102 and 104 and power electronics circuit 116 and a pre-charge circuit 132. Battery load leveling system 100 also includes a passive storage device 140, such as an ultracapacitor for example, that is wired in series with a unidirectional conducting apparatus 142, such as a diode for example, a current limiting switch 144, a first resistor 146, a second resistor 148, and a semiconductor switch 150 such as, but not limited to a silicon-controlled rectifier, a bipolar transistor, a Metal Oxide Semiconductor Field Effect Transistor (MOSFET), and a Gate Turnoff Thyristor (GTO). An energy storage system controller 160 responsive to a throttle or brake command generated by the operator provides control signals over a control link to power electronic circuit 118. Ultracapacitor as used herein is comprised of multiple series connected capacitor cells where each ultracapacitor cell has a capacitance that is greater than 100 Farads. In the exemplary embodiment, the ultracapacitors described herein have a cell capacitance that is greater than 1000 Farads per cell.

As such, battery load leveling system 100 is operable in either a higher voltage series arrangement or a lower voltage parallel arrangement. For example, at low traction drive motor speeds, the battery switching circuit 110 is configured in the lower voltage parallel mode, i.e. contactors 120 and 122 are both closed and contactor 124 is open. As such, the batteries 102 and 104 are coupled in parallel to buses 112 and 114, respectively. Approximately simultaneously, the passive storage device 140, e.g. the ultracapacitor initially starts to pre-charge via the current limiting switch 144. More specifically, resistor 146, given sufficient time, allows the ultracapacitor 140 to be charged to a maximum of within a diode drop of the battery terminal voltage, i.e. the combined voltages of batteries 102 and 104 arranged in a series or parallel configuration. Alternatively, especially in a hybrid vehicle, the drive system initially could function on the battery energy storage alone and the ultracapacitor 140 can be pre-charged during vehicle deceleration using the vehicles' kinetic energy or regenerative power during operation of motor 106 as a generator through inverter 118 through SCR 150 and current limiting resistor 148. Pre-charge circuit 132 is utilized to charge the DC link filter capacitor, contained within the traction drive system 118 as shown in FIG. 2, thereby reducing the transient current stress on the main DC contactor 130.

Specifically, the current limiting switch 144 is sensitive to current amplitude, and is selected to have a relatively low resistance at low current and a high resistance to high current. Accordingly, when load 106 is drawing a nominal amount of current, batteries 102 and 104 provide charging current for passive storage device 140 through the relatively low impedance of current limiting switch 144 without dissipating excessive power in the resistance of switch 144. However, if energy storage device 140 has been deeply discharged so that its voltage is substantially less than the nominal combined battery voltages, increased current drawn through current limiting switch 144 will cause the switch 144 to transition into a relatively high resistance state selected to be substantially greater than the resistance of fixed resistor 146.

Accordingly, the ultracapacitor or passive energy storage device **144** will be recharged by current through resistance **146**. Preferably, the ohmic value of resistance **146** is selected to provide a current level that will recharge the capacitor **144** in approximately thirty to sixty seconds, depending upon battery conditions. Current limiting apparatus **144** thus provides improved load leveling of the batteries by preventing high current recharge of ultracapacitor **140** from the batteries **102** and **104** immediately after the system experiences high power pulse loads due to heavy current draw in load **106** such as would be occasioned by rapid vehicle acceleration where load **106** comprises an AC or DC electric motor. The design of current limiting switch **144** is selected such that the switch does not oscillate as the ultracapacitor **140** charge current exponentially decreases with increasing voltage on the ultracapacitor.

Moreover, in one embodiment, the energy storage system controller (ECSS) may be a processor that utilizes feedback signals from a plurality of relative low-cost voltage sensors **162** and conventional contactor driver circuits coupled to contactors **120**, **122**, and **124**, to facilitate operating contactors **120**, **122**, and **124**, respectively. As such, when the vehicle is operating at a relatively low speed, the parallel contactors, **120** and **122**, are configured as “normally closed” with the assumption that the traction drive spends the majority of the time operating at a relatively low speed, as typical in stop and go driving for utility delivery vehicle applications. Logic in the energy storage system controller **160** also provides sufficient sequencing “lockouts” and appropriate time delays to enable the “parallel” mode contactors, **120** and **122** to be opened prior to the “series” mode contactor **124** being closed, and visa-versa.

More specifically, when the vehicle is operated in a regenerative mode, e.g. during light braking for example, battery load leveling system **100** is configured such that the main contactor **130** is opened after initially being in the “parallel mode” during periods of moderate regenerative energy capture that is based on the level of operator input brake commands.

Additionally, when operating the batteries in relative low power parallel mode, the SCR **150** is gated “on” allowing current to flow through current limiting resistor **148** to charge the ultracapacitor **140**, thus allowing the voltage on the ultracapacitor **140** to increase substantially above the battery voltage thereby providing an increased level of energy storage compared to the known configuration illustrated in FIG. 2. Provided that the voltage on the ultracapacitor **140** is less than a predetermined threshold voltage of the nominal voltage in the “series mode”, the main contactor **130** remains open to allow a portion of the energy stored in ultracapacitor **140** to be utilized during the next acceleration event. At a point where the voltage difference between the parallel battery arrangement, e.g. **102** and **104** are arranged in a parallel, and the ultracapacitor **140** is within a predetermined voltage level, the ECSS **160** issues a command to close the main contactor **130**. Similarly, during operation at light regenerative energy capture, the ESSC ensures that the main contactor **130** remains closed to facilitate increasing the life of the mechanical contactor. Additional control details are described with reference to FIG. 8.

The battery load leveling system **100** shown in FIG. 3 allows an increased level of energy storage within the ultracapacitor, compared to the prior art as shown in FIG. 2 with the assumption that the nominal voltage of both the battery, in the series configuration, and the ultracapacitor, are the same voltage rating. Moreover, battery load leveling system **100** provides a relatively low-cost implementation that provides

partial decoupling of the traction battery from the DC link and therefore increases the overall drive system efficiency.

FIG. 4 is a system **200** that includes a battery switching circuit **210**. System **200** is substantially similar to battery load leveling system **100** with the exception of battery switching circuit **210**. In the exemplary embodiment, circuit **210** is a series/parallel circuit that allows the main contactor **130** (shown in FIG. 3) to be eliminated. Circuit **210** includes a first contactor **212**, a second contactor **214**, a third contactor **216**, and a fourth contactor **218** that are each normally open contactors.

Specifically, contactors **212** and **218** are coupled in series to facilitate reducing the voltage across the individual contactors. Optionally, circuit **210** includes a single contactor that includes a sufficient voltage rating such that at least one of the contactors **212** or **218** may be eliminated, and this simplification is included in this embodiment. In the exemplary embodiment, circuit **210** also includes a mechanical interlock **215** to facilitate preventing both series and parallel contactors from closing simultaneously, in the remote situation where the ESSC logic, electrical noise on the gate driver commands, and/or contact welding prevents one of the sets of contactors from opening.

More specifically, first and fourth contactors **212** and **218** are coupled in series between the positive terminal of first battery **102** and the negative terminal of the second battery **104**, second contactor **214** is coupled between the positive terminal of first battery **102** and the positive bus **112**, and third contactor **216** is coupled between the negative terminal of the first battery **102** and the negative terminal of the second battery **104**.

System **200** also includes a first precharge circuit **230**, a second precharge circuit **232**, and a third precharge circuit **234** that are utilized to precharge the DC link filter capacitor located within the DC-AC inverter **118**, (similar function as the precharge circuit **132** in FIG. 3) thus reducing the current stress on the contactors and DC link filter capacitor during transient operation while closing contactors **212**, **214**, **216**, and **218**, respectively. Fourth precharge circuit **134** is an optional circuit that allows precharge of ultracapacitor **140** from the battery system in a shorter time compared to the current limited switch and resistor **146** as discussed previously.

To operate system **200** in a lower voltage parallel arrangement, mechanical interlock **214** is positioned in a first position such that contactors **212** and **218** are open and such that contactors **214** and **216** are closed. As such, batteries **102** and **104** are coupled in parallel to provide power to bus **112**. To operate system **200** in a higher voltage series arrangement, mechanical interlock **214** is positioned in a second position such that contactors **212** and **218** are closed and such that contactors **214** and **216** are open. As such, batteries **102** and **104** are coupled in series to bus **112**.

Moreover, the pre-charge circuit **230**, **232**, and **234** are utilized to pre-charge the DC link capacitor,  $C_{dc}$ , (shown on FIG. 2) that is housed within the electric motor traction drive or DC Load. Control of this embodiment is similar to the control of battery load leveling system **100** shown in FIG. 3 and will be discussed later herein.

FIG. 5 illustrates a system **300** that includes a battery switching circuit **310**. System **300** is substantially similar to battery load leveling system **100** with the exception of battery switching circuit **310**. In the exemplary embodiment, the parallel contactors **214** and **216** (shown in FIG. 4) are replaced with diodes **312** and **314** respectively.

During acceleration or operation at relatively constant speed and low motor speed operation, the series contactor **120**

is open and the batteries **102** and **104** are configured in a parallel arrangement via diodes **312** and **314**. As such, the power required to accelerate or operate at nearly constant speed is provided to the electric motor drive or load **106** by a combination of the batteries **102** and **104** and the ultracapacitor **140**, as shown in FIGS. **3** and **4**. Optionally, during vehicle deceleration, regenerative power is blocked from flowing into the batteries **102** and **104** by the diodes **312** and **314**, and therefore the regenerative energy is captured in the ultracapacitor **140**. As such, the voltage of the ultracapacitor **140** increases approximately linearly as a function of the regenerative current that flows through SCR **150** and current limiting resistor **148**. For high levels of regenerative power, i.e. during vehicle operation on a long down-hill grade, the voltage on the ultracapacitor **140** will increase substantially. As the ultracapacitor voltage rises to within a predetermined voltage of the projected battery voltage in the series configuration, contactor **120** is closed and the regenerative power is now applied to both the batteries **102** and **104** (arranged in a series configuration) and the ultracapacitor **140**.

FIG. **6** is a system **400** that includes a battery switching circuit **410**. System **400** is substantially similar to system **300** with the exception of battery switching circuit **410**. In the exemplary embodiment, the function of the electrical disconnect, i.e. series contactor **120** shown in FIG. **5**, is implemented utilizing back-to-back SCR's **412** and **414**, respectively. Optionally, circuit **410** includes at least two fuses **430** and **432** to facilitate limiting the current from batteries **102** and **104**, respectively.

During operation, when the vehicle is accelerating or climbing a relatively steep hill and additional power is required, SCR **414** is activated such that first battery **102** and second battery **104** are placed in a series arrangement between buses **112** and **114**, respectively. Additionally, a fuse **432** facilitates limiting the current to bus **112**.

When the vehicle is operating a mode wherein less power is required, both SCR **412** and SCR **414** are deactivated such that first battery **102** and second battery **104** are placed in a parallel arrangement between buses **112** and **114**, respectively. Specifically, current from first battery **102** is channeled through a diode **422** and fuse **430** to first bus **112**, and current is channeled from second battery **104** through diode **426** and fuse **432** to bus **112** to power load **106**.

Optionally, when the vehicle is descending a relatively steep incline the vehicle is configured to operate in a regeneration mode. Specifically, SCR **412** is activated and SCR **414** is deactivated such that current flows from bus **112** through fuse **432** through battery **104** through SCR **412** through first battery **102** through fuse **430** to complete the electrical circuit to bus **114** and thus facilitates charging both the first battery **102** and second battery **104** connected in a series arrangement. Diodes **422** and **426** restrict current from being channeled to the first and second batteries in a parallel arrangement.

FIG. **7** is a system **500** that includes a battery switching circuit **510**. System **500** is substantially similar to system **400** with the exception of battery switching circuit **510**. In the exemplary embodiment, circuit **510** also includes a first contactor **540** and a second contactor **542**. In the exemplary embodiment, the function of the electrical disconnect, i.e. series contactor **120** shown in FIG. **5**, is implemented utilizing back-to-back SCR's **512** and **514**, respectively. Optionally, circuit **510** includes at least two fuses **530** and **532** to facilitate limiting the current from batteries **102** and **104**, respectively. Circuit **510** also includes a first contactor **540** and a second contactor **542** that facilitate allowing galvanic isolation and to also facilitate preventing leakage current

flowing through batteries **102** and **104** while the battery temperature is low and in the "frozen state". As used herein the batteries are operating in a froze state when the operational temperature of the battery is less than approximately 140 degrees Celsius.

In the exemplary embodiment, batteries **102** and **104** are implemented using at least one of a sodium nickel chloride battery or a sodium sulfur battery that are each configured to operate at a temperature that is greater than 260 degrees Celsius. In the exemplary embodiment, the sodium nickel chloride battery and the sodium sulfur battery each have a high specific energy that is greater than approximately 100 Watt/hours per kilogram. Moreover, the batteries are relatively inexpensive and may be effectively cooled utilizing ambient air conditions, such as air or water cooling, for example.

In another embodiment, batteries **102** and **104** are implemented using a fuel cell, a nickel metal hydride battery, a lithium ion battery, a lithium polymer battery, a nickel cadmium battery, and a lead acid battery. Moreover, although system **500** illustrates contactors **540** and **542** positioned on only one side of a respective battery **102** and **104**, it should be realized that contactors may be coupled to both terminals of each respective battery **102** and **104** to provide further protection from the detrimental leakage current and are therefore also included in this embodiment.

In a first mode of operation operating the vehicle in a steep downhill grade for example, when the vehicle is reaching relatively high regenerative power levels, and/or operating over long distance such that the voltage on the series connected batteries reaches approximately the maximum limit, an over-voltage protection algorithm installed within the electric motor traction drive (not shown in above embodiments) gradually reduces the level of regenerative power while maintaining the DC link voltage, i.e. bus **112** voltage, at acceptable limits. As this occurs, the vehicle operator will sense a reduction in electrical braking torque and will compensate by depressing the brake pedal further, thus effectively increasing the mechanical braking power as the electrical braking power is reduced.

During operation, system **500** utilizes feedback indicative of the motor **106** speed and torque, ultracapacitor voltage, and battery voltage to operate system **500**. Moreover, whenever possible, system **500** utilizes the energy stored within ultracapacitor **140** to supplement vehicle operation. For example, during heavy vehicle acceleration, batteries **102** and **104** are placed in series arrangement, the ultracapacitor **140** voltage is charged to within approximately a diode drop of the battery voltage, and both the ultracapacitor **140** and battery **102** and **104**, share the power primarily based on the open circuit voltage and associated internal resistance of the battery **102** and **104** and ultracapacitor **140**. Optionally, during low speed operation, batteries **102** and **104** are arranged in a parallel arrangement and regenerative energy capture allows the voltage on the ultracapacitor **140** to increase to levels above the (parallel configured) battery voltage. In this situation, the next acceleration uses stored energy from the ultracapacitor **140** until the ultracapacitor voltage is approximately equal to the battery voltage.

FIG. **8** is a graphical illustration of a method of controlling the systems shown in FIGS. **3-7**. In the exemplary embodiment, the initial motor speed is shown to be approximately zero rpm and the ultracapacitor is pre-charged to essentially the battery voltage with the batteries configured in parallel. As shown, nearly constant torque is initially applied, the motor speed increases and power is supplied by both the parallel configured battery and the ultracapacitor. When the

torque is suddenly decreased to approximately 30% of rated, i.e. the vehicle and/or drive is in the cruise mode, the battery voltage increases abruptly, while the ultracapacitor slowly increases due to either the current limited switch or the pre-charge circuit. However, during regenerative braking, the energy is applied to the ultracapacitor and the voltage increase is approximately a linear function of the regenerative brake current. For this example, the ultracapacitor voltage during the regenerative braking mode did not reach the voltage threshold where the Energy Storage System Controller commands the batteries to be configured in the series mode. Thus during the next acceleration, initially all of the energy to accelerate the drive and/or vehicle is supplied from the ultracapacitor. When the ultracapacitor voltage reaches a threshold voltage of the batteries in the parallel configuration, then power is smoothly transitioned and supplied by both the batteries and ultracapacitors.

At a point approximately 50% motor speed and above, the ultracapacitor voltage is increased. The exact method of increasing the voltage on the ultracapacitor is a function of the specific embodiment and application. In general the capacitor is either pre-charged from the batteries configured to the series configuration (shown in FIGS. 3-7), or by another source, including regenerative braking. During the period when the ultracapacitor voltage is lower than the battery voltage, the battery is supplying all of the power. In a hybrid vehicle, for example, a combination of engine power plus configuring the drive in a regenerative mode, could be used to reduce the time to recharge the ultracapacitor, compared to a conventional pre-charge circuit using the batteries alone. It is envisioned that the majority of the time the drive will be operating at lower speeds and therefore the frequency of this specific transition during full power is minimal. An alternative control technique is to have an automatic, computer controlled, algorithm that during highway mode type of operation, where the drive is routinely operated in the higher speed and power ranges, the control would force the batteries in the series configuration. Only after predetermined conditions, i.e. when the drive is again operated in a lower speed operation for a given length of time or distance, the automated control would switch the batteries back to the parallel configuration the next time the vehicle is stationary.

Although, FIG. 8 illustrates the system switching the batteries from a parallel arrangement to a series arrangement when the motor speed is approximately 50%, it should be realized that the systems described herein will reconfigure the batteries from a parallel mode to a series mode utilizing a plurality of inputs received from the system such as but not limited to, vehicle speed, motor torque, motor speed, and other inputs. As such, FIG. 8 is an exemplary embodiment, and it should be realized that the batteries may be switched from parallel to series or from series to parallel above 50% motor speed or below 50% motor speed.

Described herein is a plurality of energy storage systems that may be utilized with electric and/or hybrid vehicle which requires high power for acceleration and high energy to climb long grades. Hybrid vehicle as used herein represents a vehicle that utilizes a combination of an electric motor and a heat engine to provide propulsive force to the vehicle. Moreover, as used herein, an electric vehicle represents a vehicle that includes a motor and a plurality of batteries, wherein the batteries provide the propulsive force to operate the vehicle.

The systems include combinations of high specific power ultracapacitors and high energy rechargeable batteries with sufficient power for initial acceleration and deceleration dur-

ing stop and go urban driving and for short bursts of power during passing maneuvers. Moreover, a relatively low cost ultracapacitor electronic interface allows decoupling of the battery from the ultracapacitor during specific periods and therefore utilizes a higher percentage of the ultracapacitor's ideal stored energy, during regenerative energy capture. This stored energy is used during future accelerations, thus saving fuel and increasing range. The system described herein also allows for proper matching of the input voltage of the traction drive to efficiently operate for both low speed urban and high speed highway driving.

As such, the system described herein facilitates providing a low cost ultracapacitor/battery interface apparatus that does not require a relatively expensive DC-DC converter. The system is robust, reliable, and provides a smooth transition between battery switching events. The solid state battery switching circuits, contactors (if used) do not have high transient current stress. The system control is based on simple voltage, motor speed feedback sensors, and/or torque command signals. The ultracapacitor interface provides an increased utilization of energy storage compared to known interface techniques. Low speed urban driving type cycles may be run primarily using the ultracapacitor thus enhancing battery life. High specific power ultracapacitor component exhibits high round-trip efficiency. The ultracapacitor is essentially on the DC link to facilitate eliminating DC-DC converter losses. The combination of ultracapacitor and a battery provide sufficient energy storage that may be utilized during long up-hill and down-hill grades for both low speed and high speed operation. Moreover, the system also provides improved overall system round-trip efficiency, i.e. ultracapacitor, battery, and/or traction drive, especially during low motor speed operation when the DC link is operated at approximately 50% of rated voltage as compared to high-speed high-power operation.

While the invention has been described in terms of various specific embodiments, those skilled in the art will recognize that the invention can be practiced with modification within the spirit and scope of the claims.

What is claimed is:

1. A battery load leveling system for an electrically powered system in which a battery is subject to intermittent high current loading, the electrically powered system including a first battery, a second, and a load coupled to the first and second batteries, said battery load leveling system comprising:

- a passive electrical energy storage device;
- a unidirectional electrical conducting apparatus coupled to the passive storage device and to the load, and the unidirectional electrical coupling apparatus configured to conduct current only from the passive storage device to the load, and the passive storage device is in parallel with the first and second batteries to the load; and
- a battery switching circuit that connects the first and second batteries in either a lower voltage parallel arrangement or a higher voltage series arrangement to allow a measurable terminal voltage of a circuit from the first and second batteries to the load to be switched from a first, higher voltage mode back and forth with a second lower voltage mode; and

when the battery switching circuit is in the second lower voltage mode, then the terminal voltage of the circuit from the first and second batteries to the load also is less than a measurable voltage of the passive storage device to the load, and the passive storage device responds to

## 11

the battery switching circuit being in the second lower voltage mode by supplying electrical current to the load; and

further comprising a pre-charge circuit configured to charge said passive storage device using [an external power source,]

[wherein said external power source comprises] a hybrid vehicle engine that charges said passive storage device through an electrical circuit with the drive configured to accept regenerative power from the load.

2. A battery load leveling system in accordance with claim 1 further comprising an electrical disconnect configured to disconnect said battery switching circuit from said passive storage device.

3. A battery load leveling system in accordance with claim 2 further comprising a controller to selectively operate said electrical disconnect based on the voltage of said passive storage device and direction and magnitude of power flow from the load.

4. A battery load leveling system in accordance with claim 1 wherein said battery switching circuit comprises a first contactor, a second contactor, and a third contactor, said first and second contactors operable to connect the first and second batteries in a lower voltage parallel arrangement, and said third contactor is operable to connect the first and second batteries in a higher voltage series arrangement.

5. A battery load leveling system in accordance with claim 4 further comprising:

a fourth contactor that is coupled in series with said first contactor;

a first apparatus for approximately simultaneously actuating said first and fourth contactors; and

a second apparatus for approximately simultaneously actuating said second and third contactor.

6. A battery load leveling system in accordance with claim 5 wherein said second apparatus comprises a mechanical interlock that is coupled between said first and fourth contactors and said second and third contactors, said mechanical interlock configured to open said first and fourth contactors and approximately simultaneously close said second and third contactors to facilitate preventing a short circuit.

7. A battery load leveling system in accordance with claim 5 further comprising a mechanical interlock configured to prevent switching said first and second batteries from a parallel arrangement to a series arrangement in the event of a fault including welded contacts.

8. A battery load leveling system in accordance with claim 1 further comprising a first diode coupled in series with said first battery and a second diode coupled in series with said second battery such that when power flows from said first and second batteries to the load, said first and second batteries are arranged in the lower voltage parallel mode.

9. A battery load leveling system in accordance with claim 8 further comprising an electrical disconnect that electrically connects said first and second batteries in a higher voltage series mode for either direction of power flow or current flow from the load.

10. A battery load leveling system in accordance with claim 9 wherein said electrical disconnect is implemented using back-to-back silicon controlled rectifiers.

11. A battery load leveling system in accordance with claim 9 wherein said electrical disconnect is implemented using a solid state switch.

12. A battery load leveling system in accordance with claim 1 wherein said first and second batteries comprise at least one

## 12

of a sodium nickel chloride battery and a sodium sulfur battery that are each operable at a temperature that is greater than 260 degrees Celsius.

13. A battery load leveling system in accordance with claim 12 further comprising at least one electrical disconnect coupled in series with one or both terminals of each of said first and second batteries to allow galvanic isolation and to prevent leakage current flowing through said first and second batteries when in a cold or frozen state.

14. A battery load leveling system in accordance with claim 1 further comprising a controller coupled to said battery switching circuit, said controller configured to connect said first and second batteries in either a lower voltage parallel arrangement or a higher voltage series arrangement based on at least one of a motor speed, a torque command, a passive storage device voltage, and a battery unit voltage.

15. A battery load leveling system in accordance with claim 1 wherein said first and second batteries comprise at least one of a sodium nickel chloride battery, a sodium sulfur battery, a fuel cell, a nickel metal hydride battery, a lithium ion battery, a lithium polymer battery, a nickel cadmium battery, and a lead acid battery.

16. A battery load leveling system in accordance with claim 1 wherein said unidirectional conducting apparatus comprises a diode.

[17. An electric vehicle comprising a battery load leveling system as defined in claim 1.]

[18. A hybrid vehicle comprising: a battery load leveling system as defined in claim 1.]

19. A battery load leveling system for an electrically powered system in which a battery is subject to intermittent high current loading, the electrically powered system including a first battery, a second, and a load coupled to the first and second batteries, said battery load leveling system comprising:

a passive electrical energy storage device;

a unidirectional electrical conducting apparatus coupled to the passive storage device and to the load, and the unidirectional electrical coupling apparatus configured to conduct current only from the passive storage device to the load, and the passive storage device is in parallel with the first and second batteries to the load; and

a battery switching circuit that connects the first and second batteries in either a lower voltage parallel arrangement or a higher voltage series arrangement to allow a measurable terminal voltage of a circuit from the first and second batteries to the load to be switched from a first, higher voltage mode back and forth with a second lower voltage mode; and

when the battery switching circuit is in the second lower voltage mode, then the terminal voltage of the circuit from the first and second batteries to the load also is less than a measurable voltage of the passive storage device to the load, and the passive storage device responds to the battery switching circuit being in the second lower voltage mode by supplying electrical current to the load; and

further comprising a pre-charge circuit configured to charge said passive storage device [using an external power source],

wherein said pre-charge circuit is configured to accept regenerative power from the load using a semiconductor switch.

20. A battery load leveling system in accordance with claim 19 wherein said semiconductor switch comprises at least one of a silicon-controlled rectifier, a bipolar transistor, a Metal



13

Oxide Semiconductor Field Effect Transistor (MOSFET) and a Gate Turnoff Thyristor (GTO).

21. A battery load leveling system for an electrically powered system in which a battery is subject to intermittent high current loading, the electrically powered system including a first battery, a second, and a load coupled to the first and second batteries, said battery load leveling system comprising:

a passive electrical energy storage device;  
a unidirectional electrical conducting apparatus coupled to the passive storage device and to the load, and the unidirectional electrical coupling apparatus configured to conduct current only from the passive storage device to the load, and the passive storage device is in parallel with the first and second batteries to the load; and

a battery switching circuit that connects the first and second batteries in either a lower voltage parallel arrangement or a higher voltage series arrangement to allow a measurable terminal voltage of a circuit from the first and second batteries to the load to be switched from a first, higher voltage mode back and forth with a second lower voltage mode; and

when the battery switching circuit is in the second lower voltage mode, then the terminal voltage of the circuit from the first and second batteries to the load also is less than a measurable voltage of the passive storage device to the load, and the passive storage device responds to the battery switching circuit being in the second lower voltage mode by supplying electrical current to the load; and

further comprising a pre-charge circuit configured to charge said passive storage device using [an external power source,]

[wherein said external power source comprises] said first and second batteries, said battery switching circuit configured to couple said first and second batteries in either a lower voltage parallel arrangement or a higher voltage series arrangement.

22. A battery load leveling system in accordance with claim 21 further comprising an electrical disconnect configured to disconnect said battery switching circuit from said passive storage device.

23. A battery load leveling system in accordance with claim 22 further comprising a controller to selectively operate said electrical disconnect based on the voltage of said passive storage device and direction and magnitude of power flow from the load.

24. A battery load leveling system in accordance with claim 21 wherein said battery switching circuit comprises a first contactor, a second contactor, and a third contactor, said first and second contactors operable to connect the first and second batteries in a lower voltage parallel arrangement, and said third contactor is operable to connect the first and second batteries in a higher voltage series arrangement.

25. A battery load leveling system in accordance with claim 24 further comprising:

a fourth contactor that is coupled in series with said first contactor;  
a first apparatus for approximately simultaneously actuating said first and fourth contactors; and  
a second apparatus for approximately simultaneously actuating said second and third contactor.

26. A battery load leveling system in accordance with claim 25 wherein said second apparatus comprises a mechanical interlock that is coupled between said first and fourth contactors and said second and third contactors, said mechanical interlock configured to open said first and fourth contactors

14

and approximately simultaneously close said second and third contactors to facilitate preventing a short circuit.

27. A battery load leveling system in accordance with claim 25 further comprising a mechanical interlock configured to prevent switching said first and second batteries from a parallel arrangement to a series arrangement in the event of a fault including welded contacts.

28. A battery load leveling system in accordance with claim 21 further comprising a first diode coupled in series with said first battery and a second diode coupled in series with said second battery such that when power flows from said first and second batteries to the load, said first and second batteries are arranged in the lower voltage parallel mode.

29. A battery load leveling system in accordance with claim 28 further comprising an electrical disconnect that electrically connects said first and second batteries in a higher voltage series mode for either direction of power flow or current flow from the load.

30. A battery load leveling system in accordance with claim 29 wherein said electrical disconnect is implemented using back-to-back silicon controlled rectifiers.

31. A battery load leveling system in accordance with claim 29 wherein said electrical disconnect is implemented using a solid state switch.

32. A battery load leveling system in accordance with claim 21 wherein said first and second batteries comprise at least one of a sodium nickel chloride battery and a sodium sulfur battery that are each operable at a temperature that is greater than 260 degrees Celsius.

33. A battery load leveling system in accordance with claim 32 further comprising at least one electrical disconnect coupled in series with one or both terminals of each of said first and second batteries to allow galvanic isolation and to prevent leakage current flowing through said first and second batteries when in a cold or frozen state.

34. A battery load leveling system in accordance with claim 21 further comprising a controller coupled to said battery switching circuit, said controller configured to connect said first and second batteries in either a lower voltage parallel arrangement or a higher voltage series arrangement based on at least one of a motor speed, a torque command, a passive storage device voltage, and a battery unit voltage.

35. A battery load leveling system for an electrically powered system in which a battery is subject to an intermittent high current loading, the system including a first battery, a second battery, and a load coupled to the first and second batteries, the system comprising:

a passive storage device;  
a unidirectional conducting apparatus coupled in a series circuit with the passive storage device and poled to conduct current from the passive storage device to the load, the series circuit coupled in parallel with the first and second batteries;  
a battery switching circuit that connects the first and second batteries in a lower voltage parallel arrangement and a higher voltage series arrangement;  
a controller configured to automatically switch the first and second batteries between the lower voltage parallel arrangement and the higher voltage series arrangement; and  
a contactor in series with at least one of the first and second batteries.

36. The battery load leveling system of claim 35 comprising a diode in series with at least one of the first and second batteries.

37. The battery load leveling system of claim 35 wherein the passive storage device is configured to provide current to the load when a battery terminal voltage is less than a voltage on the passive storage device.

38. The battery load leveling system of claim 35 wherein the battery switching circuit comprises at least one semiconductor switch.

39. The battery load leveling system of claim 38 wherein the at least one semiconductor switch includes a silicon controlled rectifier.

40. A battery load leveling system for an electrically powered system in which a battery is subject to an intermittent high current loading, the system including a first battery, a second battery, and a load coupled to the first and second batteries, the system comprising:

a passive storage device;

a unidirectional conducting apparatus coupled in a series circuit with the passive storage device and poled to conduct current from the passive storage device to the load, the series circuit coupled in parallel with the first and second batteries;

a battery switching circuit that connects the first and second batteries in a lower voltage parallel arrangement and a higher voltage series arrangement; and

a controller configured to automatically switch the first and second batteries between the lower voltage parallel arrangement and the higher voltage series arrangement;

wherein the battery switching circuit is free of a mechanical switching device; and

wherein the controller is configured to switch between the lower voltage parallel arrangement and the higher voltage series arrangement based on one of a vehicle speed, a motor torque, and a motor speed.

41. The battery load leveling system of claim 40 comprising a contactor and a diode in series with at least one of the first and second batteries.

42. The battery load leveling system of claim 40 wherein at least one of the first and second batteries comprises one of a nickel metal hydride battery, a lithium polymer battery, a nickel cadmium battery, and a lead acid battery.

43. The battery load leveling system of claim 40 wherein the passive storage device is configured to provide current to the load when a battery terminal voltage is less than a voltage on the passive storage device.

44. A battery load leveling system for an electrically powered system in which a battery is subject to an intermittent high current loading, the system including a first battery, a second battery, and a load coupled to the first and second batteries, the system comprising:

a passive storage device coupled in parallel with the first and second batteries;

a battery switching circuit that connects the first and second batteries in a lower voltage parallel arrangement and a higher voltage series arrangement, wherein the battery switching circuit comprises at least one silicon controlled rectifier; and

a controller coupled to the battery switching circuit, the controller configured to connect the first and second batteries in either a lower voltage parallel arrangement or a higher voltage series arrangement based on at least one of a motor speed, a torque command, a passive storage device voltage, and a battery unit voltage.

45. The battery load leveling system of claim 44 comprising a unidirectional conducting apparatus coupled in a series circuit with the passive storage device and poled to conduct current from the passive storage device to the load.

46. The battery load leveling system of claim 44 wherein the passive storage device is configured to provide current to the load when a battery terminal voltage is less than a voltage on the passive storage device.

47. A battery load leveling system for an electrically powered system in which a battery is subject to an intermittent high current loading, the system including a first battery, a second battery, and a load coupled to the first and second batteries, the system comprising:

a passive storage device;

a unidirectional conducting apparatus coupled in a series circuit with the passive storage device and poled to conduct current from the passive storage device to the load, the series circuit coupled in parallel with the first and second batteries;

a battery switching circuit that connects the first and second batteries in a lower voltage parallel arrangement and a higher voltage series arrangement; and

a controller configured to automatically switch the first and second batteries between the lower voltage parallel arrangement and the higher voltage series arrangement;

wherein the controller is configured to implement a time delay to enable a parallel mode contactor to be opened prior to a series mode contactor being closed.

48. A battery load leveling system for an electrically powered system in which a battery is subject to an intermittent high current loading, the system including a first battery, a second battery, and a load coupled to the first and second batteries, the system comprising:

a passive storage device;

a unidirectional conducting apparatus coupled in a series circuit with the passive storage device and poled to conduct current from the passive storage device to the load, the series circuit coupled in parallel with the first and second batteries;

a battery switching circuit that connects the first and second batteries in a lower voltage parallel arrangement and a higher voltage series arrangement; and

a controller configured to automatically switch the first and second batteries between the lower voltage parallel arrangement and the higher voltage series arrangement;

wherein the controller is configured to switch between the lower voltage parallel arrangement and the higher voltage series arrangement based on one of a vehicle speed, a motor torque, and a motor speed.

49. A battery load leveling system for an electrically powered system in which a battery is subject to an intermittent high current loading, the system including a first battery, a second battery, and a load coupled to the first and second batteries, the system comprising:

a passive storage device;

a unidirectional conducting apparatus coupled in a series circuit with the passive storage device and poled to conduct current from the passive storage device to the load, the series circuit coupled in parallel with the first and second batteries;

a battery switching circuit that connects the first and second batteries in a lower voltage parallel arrangement and a higher voltage series arrangement;

a controller configured to automatically switch the first and second batteries between the lower voltage parallel arrangement and the higher voltage series arrangement; and

a switch that couples the load to the series circuit;

wherein the controller is configured to activate the switch such that current flows from the load, when the electrically powered system is operated in a regenerative braking mode, to the passive storage device, such that a voltage across the passive storage device is greater than a voltage across a parallel arrangement of the first and second batteries.

50. A battery load leveling system for an electrically powered system in which a battery is subject to an intermittent high current loading, the system including a first battery, a second battery, and a load coupled to the first and second batteries, the system comprising:

a passive storage device;

a unidirectional conducting apparatus coupled in a series circuit with the passive storage device and poled to conduct current from the passive storage device to the load, the series circuit coupled in parallel with the first and second batteries;

a battery switching circuit that connects the first and second batteries in a lower voltage parallel arrangement and a higher voltage series arrangement;

a controller configured to automatically switch the first and second batteries between the lower voltage parallel arrangement and the higher voltage series arrangement; and

a main contactor coupled between the first and second batteries and the load, wherein the controller operates the main contactor based on a voltage difference between a voltage on the parallel battery arrangement and a voltage on the passive storage device.

51. The battery load leveling system of claim 50 wherein the controller is configured to operate the main contactor based on an amount of regenerative braking of the electrically powered system.

52. A battery load leveling system for an electrically powered system in which a battery is subject to an intermittent high current loading, the system including a first battery, a second battery, and a load coupled to the first and second batteries, the system comprising:

a passive storage device;

a unidirectional conducting apparatus coupled in a series circuit with the passive storage device and poled to conduct current from the passive storage device to the load, the series circuit coupled in parallel with the first and second batteries;

a battery switching circuit that connects the first and second batteries in a lower voltage parallel arrangement and a higher voltage series arrangement; and

a controller configured to automatically switch the first and second batteries between the lower voltage parallel arrangement and the higher voltage series arrangement;

wherein the controller is configured to maintain the parallel arrangement of the first and second batteries during a regenerative braking event of the electrically powered system based on a voltage level generated from the regenerative braking event.

53. A battery load leveling system for an electrically powered system in which a battery is subject to an intermittent high current loading, the system including a first battery, a second battery, and a load coupled to the first and second batteries, the system comprising:

a passive storage device;

a unidirectional conducting apparatus coupled in a series circuit with the passive storage device and poled to

conduct current from the passive storage device to the load, the series circuit coupled in parallel with the first and second batteries;

a battery switching circuit that connects the first and second batteries in a lower voltage parallel arrangement and a higher voltage series arrangement;

a controller configured to automatically switch the first and second batteries between the lower voltage parallel arrangement and the higher voltage series arrangement; and

a pre-charge circuit configured to charge the passive storage device.

54. A battery load leveling system for an electrically powered system in which a battery is subject to an intermittent high current loading, the system including a first battery, a second battery, and a load coupled to the first and second batteries, the system comprising:

a passive storage device;

a unidirectional conducting apparatus coupled in a series circuit with the passive storage device and poled to conduct current from the passive storage device to the load, the series circuit coupled in parallel with the first and second batteries;

a battery switching circuit that connects the first and second batteries in a lower voltage parallel arrangement and a higher voltage series arrangement; and

a controller configured to automatically switch the first and second batteries between the lower voltage parallel arrangement and the higher voltage series arrangement wherein the battery switching circuit is free of a mechanical switching device; and

wherein the controller is configured to implement a time delay to enable a parallel mode operation of the battery switching circuit to be implemented prior to a series mode operation of the battery switching circuit being closed.

55. A battery load leveling system for an electrically powered system in which a battery is subject to an intermittent high current loading, the system including a first battery, a second battery, and a load coupled to the first and second batteries, the system comprising:

a passive storage device;

a unidirectional conducting apparatus coupled in a series circuit with the passive storage device and poled to conduct current from the passive storage device to the load, the series circuit coupled in parallel with the first and second batteries;

a battery switching circuit that connects the first and second batteries in a lower voltage parallel arrangement and a higher voltage series arrangement;

a controller configured to automatically switch the first and second batteries between the lower voltage parallel arrangement and the higher voltage series arrangement; and

a switch that couples the load to the series circuit; wherein the battery switching circuit is free of a mechanical switching device; and

wherein the controller is configured to activate the switch such that current flows from the load, when the electrically powered system is operated in a regenerative braking mode, to the passive storage device, such that a voltage across the passive storage device is greater than a voltage across a parallel arrangement of the first and second batteries.

56. A battery load leveling system for an electrically powered system in which a battery is subject to an intermittent high current loading, the system including a first battery, a

19

second battery, and a load coupled to the first and second batteries, the system comprising:

a passive storage device;

a unidirectional conducting apparatus coupled in a series circuit with the passive storage device and poled to conduct current from the passive storage device to the load, the series circuit coupled in parallel with the first and second batteries;

a battery switching circuit that connects the first and second batteries in a lower voltage parallel arrangement and a higher voltage series arrangement;

a controller configured to automatically switch the first and second batteries between the lower voltage parallel arrangement and the higher voltage series arrangement; and

a main contactor coupled between the first and second batteries and the load that is switchable based on a voltage difference between a voltage on the lower voltage parallel battery arrangement and a voltage on the passive storage device;

wherein the battery switching circuit is free of a mechanical switching device.

57. The battery load leveling system of claim 56 wherein the controller is configured to operate the main contactor based on an amount of regenerative braking of the electrically powered system.

20

58. A battery load leveling system for an electrically powered system in which a battery is subject to an intermittent high current loading, the system including a first battery, a second battery, and a load coupled to the first and second batteries, the system comprising:

a passive storage device;

a unidirectional conducting apparatus coupled in a series circuit with the passive storage device and poled to conduct current from the passive storage device to the load, the series circuit coupled in parallel with the first and second batteries;

a battery switching circuit that connects the first and second batteries in a lower voltage parallel arrangement and a higher voltage series arrangement; and

a controller configured to automatically switch the first and second batteries between the lower voltage parallel arrangement and the higher voltage series arrangement; and

wherein the battery switching circuit is free of a mechanical switching device; and

wherein the controller is configured to maintain the lower voltage parallel arrangement of the first and second batteries during regenerative braking of the electrically powered system based on a voltage level generated from the regenerative braking.

\* \* \* \* \*