

US00RE43955E

(19) **United States**  
(12) **Reissued Patent**  
**Shkolnik et al.**

(10) **Patent Number:** **US RE43,955 E**  
(45) **Date of Reissued Patent:** **Feb. 5, 2013**

(54) **PROCESS FOR THE PRODUCTION OF A THREE-DIMENSIONAL OBJECT WITH RESOLUTION IMPROVEMENT BY PIXEL-SHIFT**

4,999,143 A 3/1991 Hull et al.  
5,093,130 A 3/1992 Fujii et al.  
5,137,662 A 8/1992 Hull et al.  
5,143,663 A 9/1992 Leyden et al.  
5,173,266 A 12/1992 Kenney  
5,174,931 A 12/1992 Almquist et al.  
5,236,637 A 8/1993 Hull

(75) Inventors: **Alexandr Shkolnik**, Los Angeles, CA (US); **Hendrik John**, Hunxe (DE); **Ali El-Sibiani**, Dearborn Heights, MI (US)

(Continued)

(73) Assignee: **Envisiontec GmbH**, Gladbeck (DE)

**FOREIGN PATENT DOCUMENTS**

DE 4105314 A1 8/1991  
DE 4102257 A1 7/1992

(21) Appl. No.: **13/230,270**

(Continued)

(22) Filed: **Sep. 12, 2011**

**OTHER PUBLICATIONS**

**Related U.S. Patent Documents**

Opposition to EP 1,849,587, dated Apr. 8, 2010.

Reissue of:

(64) Patent No.: **7,790,093**  
Issued: **Sep. 7, 2010**  
Appl. No.: **11/126,068**  
Filed: **May 9, 2005**

(Continued)

U.S. Applications:

(60) Provisional application No. 60/569,893, filed on May 10, 2004.

*Primary Examiner* — Joseph Del Sole  
*Assistant Examiner* — Kimberly A Stewart  
(74) *Attorney, Agent, or Firm* — Hansen IP Law PLLC

(30) **Foreign Application Priority Data**

May 10, 2004 (DE) ..... 10 2004 022 961

(57) **ABSTRACT**

(51) **Int. Cl.**  
**G02F 1/00** (2006.01)  
(52) **U.S. Cl.** ..... **264/401; 700/120; 264/497**  
(58) **Field of Classification Search** ..... **264/401, 264/497; 700/120**  
See application file for complete search history.

The invention relates to a process or a device for the production of a three-dimensional object by layer-wise solidification of a material which is solidifiable under the application of electromagnetic irradiation by means of mask illumination, wherein the mask is produced using an image forming unit having a prescribed resolution, which is formed from a constant number of image forming elements (pixels) being discrete and being arranged in a spatially mutually fixed manner. For the improvement of the resolution along the outer and inner contours of the sectional areas of the object to be generated layer-wise in the sub-pixel range, a multiple illumination per layer is performed, which consists of a series of multiple images that are mutually shifted in the sub-pixel range in the image/construction plane, wherein a separate mask/bitmap is produced for each shifted image.

(56) **References Cited**

**U.S. PATENT DOCUMENTS**

4,575,330 A 3/1986 Hull  
4,837,379 A 6/1989 Weinberg  
4,929,402 A 5/1990 Hull

**24 Claims, 7 Drawing Sheets**

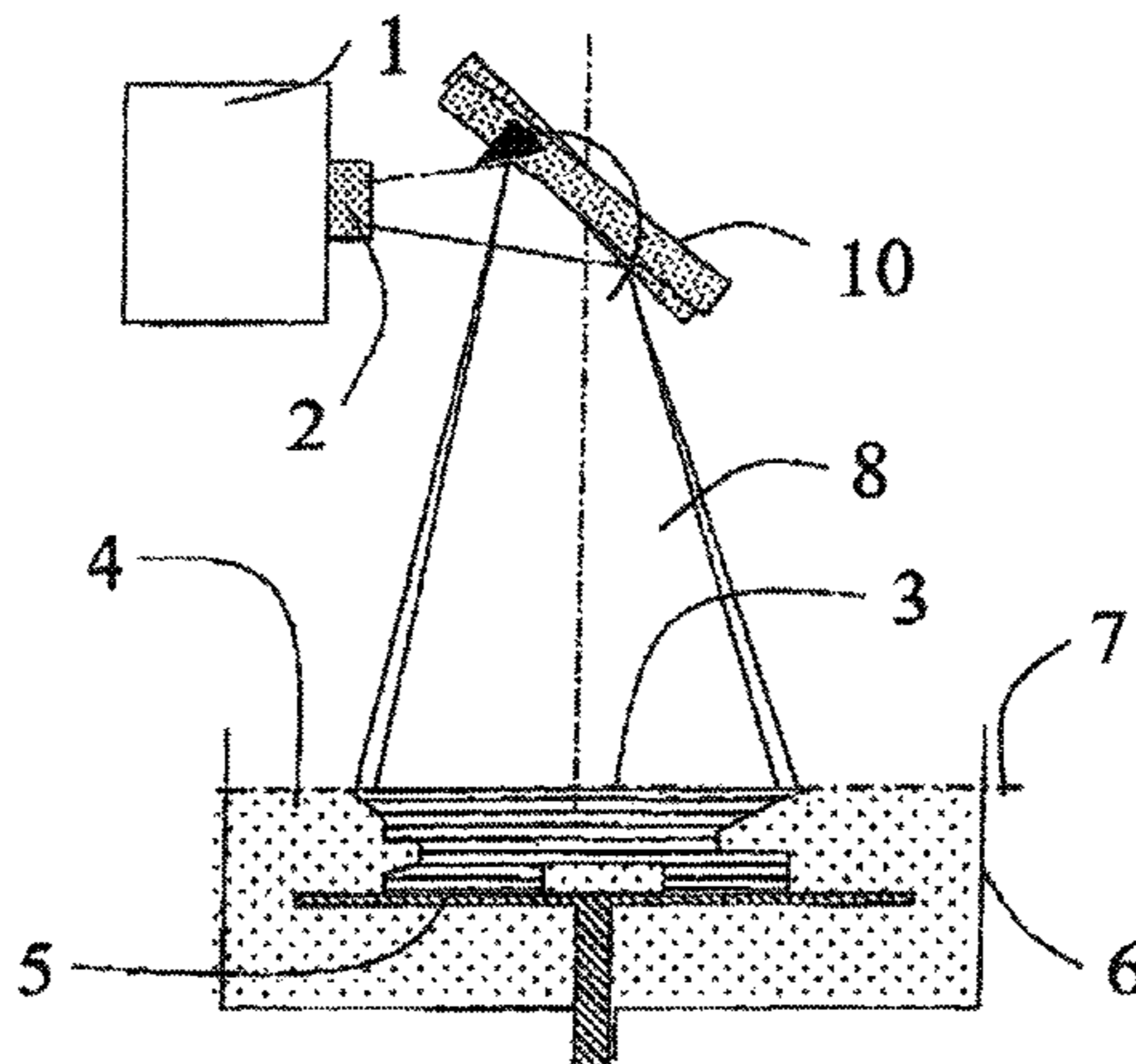

# US RE43,955 E

Page 2

## U.S. PATENT DOCUMENTS

5,247,180 A 9/1993 Mitcham et al.  
 5,248,456 A 9/1993 Evans, Jr. et al.  
 5,254,979 A 10/1993 Trevett et al.  
 5,263,130 A 11/1993 Pomerantz et al.  
 5,268,994 A 12/1993 Keskes  
 5,298,208 A 3/1994 Sibley et al.  
 5,306,446 A 4/1994 Howe  
 5,345,391 A 9/1994 Hull et al.  
 5,360,981 A 11/1994 Owen et al.  
 5,391,072 A 2/1995 Lawton et al.  
 5,437,820 A 8/1995 Brotz  
 5,447,822 A 9/1995 Hull et al.  
 5,510,077 A 4/1996 Dinh et al.  
 5,529,473 A 6/1996 Lawton et al.  
 5,545,367 A 8/1996 Bae et al.  
 5,569,431 A 10/1996 Hull  
 5,571,471 A 11/1996 Hull  
 5,630,981 A 5/1997 Hull  
 5,651,934 A 7/1997 Almquist et al.  
 5,653,925 A 8/1997 Batchelder  
 5,823,778 A 10/1998 Schmitt et al.  
 5,858,746 A 1/1999 Hubbell et al.  
 5,891,382 A 4/1999 Almquist et al.  
 5,894,036 A 4/1999 Tylko  
 5,897,825 A 4/1999 Fruth et al.  
 5,902,537 A 5/1999 Almquist et al.  
 5,943,235 A 8/1999 Earl et al.  
 5,980,813 A 11/1999 Narang et al.  
 6,013,099 A 1/2000 Dinh et al.  
 6,027,324 A 2/2000 Hull  
 6,048,487 A 4/2000 Almquist et al.  
 6,051,179 A 4/2000 Hagenau  
 6,078,038 A 6/2000 Cooper  
 6,124,858 A 9/2000 Ge et al.  
 6,158,946 A 12/2000 Miyashita  
 6,171,610 B1 1/2001 Vacanti et al.  
 6,180,050 B1 1/2001 Arai et al.  
 6,280,727 B1 8/2001 Prior et al.  
 6,334,865 B1 1/2002 Redmond et al.  
 6,352,710 B2 3/2002 Sawhney et al.  
 6,391,245 B1 5/2002 Smith  
 6,500,378 B1 12/2002 Smith  
 6,501,483 B1 12/2002 Wong et al.  
 6,508,971 B2 1/2003 Leyden et al.  
 6,547,552 B1 4/2003 Fudim  
 6,600,965 B1 7/2003 Hull et al.  
 6,630,009 B2 10/2003 Moussa et al.  
 6,764,636 B1 7/2004 Allanic et al.  
 6,833,231 B2 12/2004 Moussa et al.  
 6,833,234 B1 12/2004 Bloomstein et al.  
 6,942,830 B2 9/2005 Mulhaupt et al.  
 6,963,319 B2 11/2005 Pate et al.  
 6,974,656 B2 12/2005 Hinczewski  
 6,989,225 B2 1/2006 Steinmann  
 7,034,811 B2 4/2006 Allen  
 7,052,263 B2 5/2006 John  
 7,128,866 B1 10/2006 Henningsen  
 7,195,472 B2 3/2007 John  
 7,403,213 B1 7/2008 Morgan et al.  
 7,467,939 B2 12/2008 Sperry et al.  
 7,758,799 B2 7/2010 Hull et al.  
 7,790,093 B2 9/2010 Shkolnik et al.  
 2001/0028495 A1 10/2001 Quate et al.  
 2001/0048183 A1 12/2001 Fujita  
 2002/0028854 A1 3/2002 Allanic et al.  
 2002/0155189 A1 10/2002 John  
 2003/0074096 A1 4/2003 Das et al.  
 2003/0173714 A1 9/2003 Ueno  
 2003/0205849 A1 11/2003 Farnworth  
 2004/0008309 A1 1/2004 Yamahara et al.  
 2004/0027363 A1 2/2004 Allen  
 2004/0028293 A1 2/2004 Allen et al.  
 2005/0023710 A1 2/2005 Brodtkin et al.  
 2005/0208168 A1 9/2005 Hickerson et al.  
 2005/0248061 A1 11/2005 Shkolnik et al.  
 2005/0248062 A1 11/2005 Shkolnik et al.  
 2005/0259785 A1 11/2005 Zhang  
 2005/0288813 A1 12/2005 Yang et al.

2006/0078638 A1 4/2006 Holmboe et al.  
 2006/0192312 A1 8/2006 Wahlstrom  
 2006/0239588 A1 10/2006 Hull et al.  
 2006/0249884 A1 11/2006 Partanen et al.  
 2007/0074659 A1 4/2007 Wahlstrom  
 2007/0075458 A1 4/2007 Wahlstrom et al.  
 2007/0075459 A1 4/2007 Reynolds et al.  
 2007/0075460 A1 4/2007 Wahlstrom et al.  
 2007/0075461 A1 4/2007 Hunter et al.  
 2007/0077323 A1 4/2007 Stonesmith et al.  
 2007/0257055 A1 11/2007 Scott et al.  
 2007/0259066 A1 11/2007 Sperry et al.  
 2008/0038396 A1 2/2008 John et al.  
 2008/0054531 A1 3/2008 Kerekes et al.  
 2008/0169586 A1 7/2008 Hull et al.  
 2008/0169589 A1 7/2008 Sperry et al.  
 2008/0170112 A1 7/2008 Hull et al.  
 2008/0179786 A1 7/2008 Sperry et al.  
 2008/0179787 A1 7/2008 Sperry et al.  
 2008/0181977 A1 7/2008 Sperry et al.  
 2008/0206383 A1 8/2008 Hull et al.  
 2008/0217818 A1 9/2008 Holmboe et al.  
 2008/0226346 A1 9/2008 Hull et al.  
 2008/0231731 A1 9/2008 Hull et al.  
 2008/0309665 A1 12/2008 Gregory, II et al.

## FOREIGN PATENT DOCUMENTS

DE 4125534 A1 2/1993  
 DE 93 19 405.6 5/1994  
 DE 9319405.6 U1 5/1994  
 DE 4340108 C2 9/1997  
 DE 197 16 240 A1 10/1998  
 DE 19716240 A1 10/1998  
 DE 197 27 554 1/1999  
 DE 19727554 A1 1/1999  
 DE 299 11 122 U1 11/1999  
 DE 29911122 U1 11/1999  
 DE 19838797 A1 3/2000  
 DE 199 29 199 A1 1/2001  
 DE 19929199 A1 1/2001  
 DE 19929199 \* 2/2001  
 DE 10003374 C1 8/2001  
 DE 100 18 987 10/2001  
 DE 10018987 A1 10/2001  
 DE 20106887 U1 10/2001  
 DE 69909136 T2 5/2004  
 DE 102004022961 A1 12/2005  
 EP 0 250 121 12/1987  
 EP 0250121 A2 12/1987  
 EP 0426363 A2 5/1991  
 EP 0 435 564 A2 7/1991  
 EP 0435564 A2 7/1991  
 EP 0 466 422 A1 1/1992  
 EP 0466422 A1 1/1992  
 EP 0 484 086 A1 5/1992  
 EP 0484086 A1 5/1992  
 EP 0 958 912 A1 11/1999  
 EP 0958912 A1 11/1999  
 EP 1 250 997 A1 10/2002  
 EP 1250997 A1 10/2002  
 EP 1 270 185 1/2003  
 EP 1270185 A1 1/2003  
 EP 1 192 041 B1 3/2003  
 EP 1192041 B1 3/2003  
 EP 1 156 922 B1 6/2003  
 EP 1156922 B1 6/2003  
 EP 1674243 A2 6/2006  
 EP 1 849 587 10/2007  
 EP 1849587 A1 10/2007  
 EP 1 880 830 1/2008  
 EP 1880830 A1 1/2008  
 EP 1 894 704 3/2008  
 EP 1894704 A1 3/2008  
 EP 1 950 032 7/2008  
 EP 1950032 A2 7/2008  
 EP 2 011 631 1/2009  
 EP 2011631 A1 1/2009  
 FR 2254194 A5 7/1975  
 FR 2583334 A1 12/1986

FR	2 692 053		12/1993
FR	2692053	A1	12/1993
JP	04371829		12/1992
JP	04371829	A	12/1992
JP	08192469		7/1996
JP	08192469	A	7/1996
WF	WO 95/11007		4/1995
WO	9511007	A1	4/1995
WO	9515841	A1	6/1995
WO	WO-95/15841		6/1995
WO	9600422	A1	1/1996
WO	WO-96/00422		1/1996
WO	0021735	A1	4/2000
WO	WO 00/21735		4/2000
WO	01/00390	A1	1/2001
WO	0112679	A1	2/2001
WO	WO-01/12679		2/2001
WO	0172501	A1	10/2001
WO	WO-01/72501	A1	10/2001
WO	0227408	A2	4/2002
WO	WO 02/27408	A2	4/2002
WO	03059184	A2	7/2003
WO	WO-03/059184		7/2003

OTHER PUBLICATIONS

C. Sun, et al., "Projection Micro-Stereolithography Using Digital Micro-Mirror Dynamic mask," *Sensors and Actuators A* 121 (2005) 113-120.

S. Ventura, et al., "Freeform Fabrication of Functional Silicon Nitride Components by Direct Photoshaping," *Mat Res. Sol. Symp. Proc.*, vol. 625 (2000).

K. Takahashi, "A New Application of DMD to Photolithography and Rapid Prototyping System," Institute of Electronics, Information, and Communication Engineers.

Wohlers Report 2000. "Rapid Prototyping & Tooling State of the Industry Annual Worldwide Progress Report", T. Wohlers, Wohlers Association, Inc., Fort Collins, Colorado (2000).

Stark, G.B., et al., "Biological Matrices and Tissue Reconstruction," Springer Publications, Berlin (1998).

Sachs, E., et al., "Three Dimensional Printing: Rapid Tooling and Prototypes Directly from CAD Model," *Journal of Engineering for Industry*, 114:481-488 (1992).

Kuhntreiber, W., Ph.D., et al., "Cell Encapsulation Technology and Therapeutics," Birkhauser, Boston (1998).

Landers, R., and Mulhaupt, R., "Desktop Manufacturing of Complex Objects, Prototypes and Biomedical Scaffolds by means of Computer-Assisted Design Combined with Computer-Guided 3D Plotting of Polymers and Reactive Oligomers," *Macromolecular Materials and Engineering*, 282:17-22 (2000).

Okada, T., and Ikada, Y., "Tissue Reactions to Subcutaneously Implanted, Surface-Modified Silicones," *Journal of Biomedical Materials Research*, 27:1509-1518 (1993).

Relou, I.A., et al., "Effect of Culture Conditions on Endothelial Cell Growth and Responsiveness," *Tissue & Cell*, 30(5):525-538 (1998).

Nikolaychik, V.V., et al., "A New, Cryoprecipitate Based Coating for Improved Endothelial Cell Attachment and Growth on Medical Grade Artificial Surfaces," *ASAIO Journal*, 40:M846-M852 (1994).

Burns, "Automatic Fabrication Improving Productivity in Manufacturing", 1993 (ISBN 0-13-119462-3).

IEEE Super Resolution article abstract vol. 20, issue 3, pp. 21-36, May 2003.

37 CFR 1.99 Submission and declaration.

<http://www.hp.com/hpinfo/newsroom/press/2004/040609a.html>

"HP technology doubles the resolution of digital projection displays" Jun. 9, 2004.

4 W. Allen, R. Ulichney "Wobulation: Doubling the Addressed Resolution," *SID 05 Digest*, 2005.

Wobulation, saved as PDF from the internet; wikipedia definition, citing several resolution-related patents.

*3D Systems, Inc. v. Envisiontec, Inc., et al.* Special Masters Report and Recommendation on the Parties' Summary Judgement Motions. International Search Report (German Translation) for PCT/EP2005/005003, dated Oct. 5, 2004.

International Preliminary Report on Patentability for PCT/EP2008/009041, dated Apr. 27, 2010.

Written Opinion of the International Searching Authority for PCT/EP2008/009041, dated Apr. 27, 2007.

International Search Report for PCT/EP2008/009040, dated Feb. 4, 2009.

Written Opinion of the International Searching Authority for PCT/EP2008/009040, dated Feb. 4, 2009.

\* cited by examiner

Fig. 1

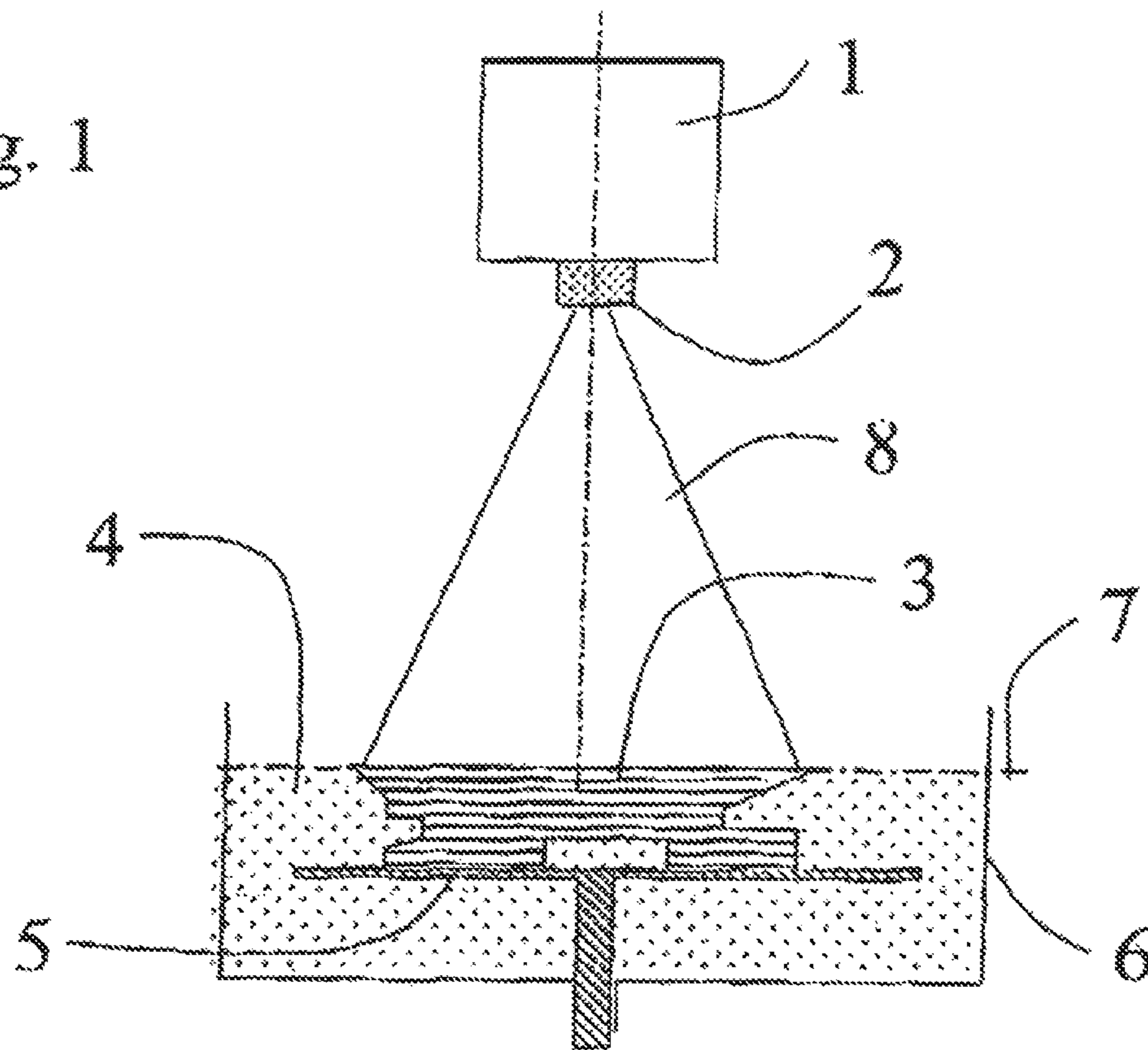

Fig. 2

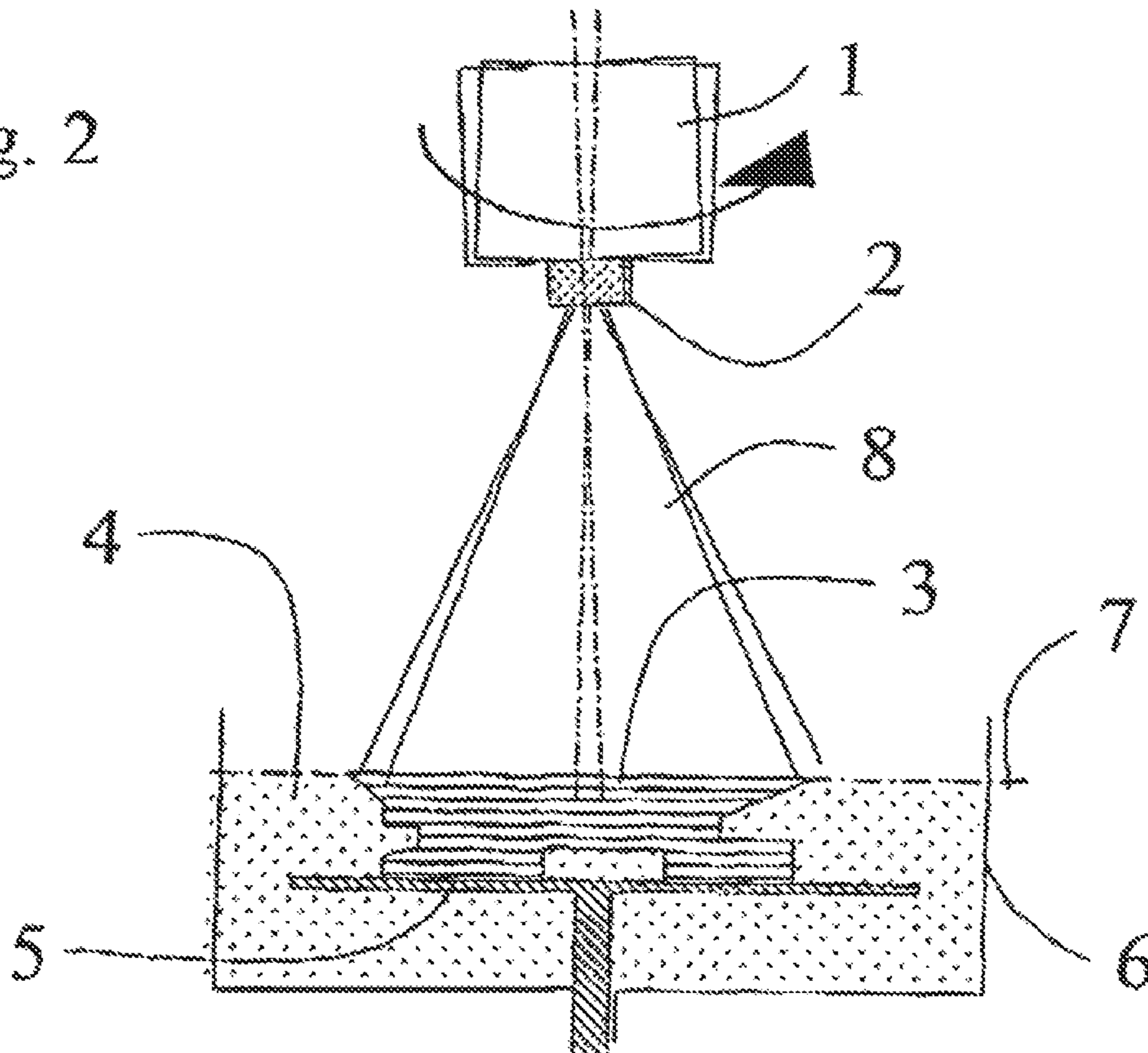

Fig. 3

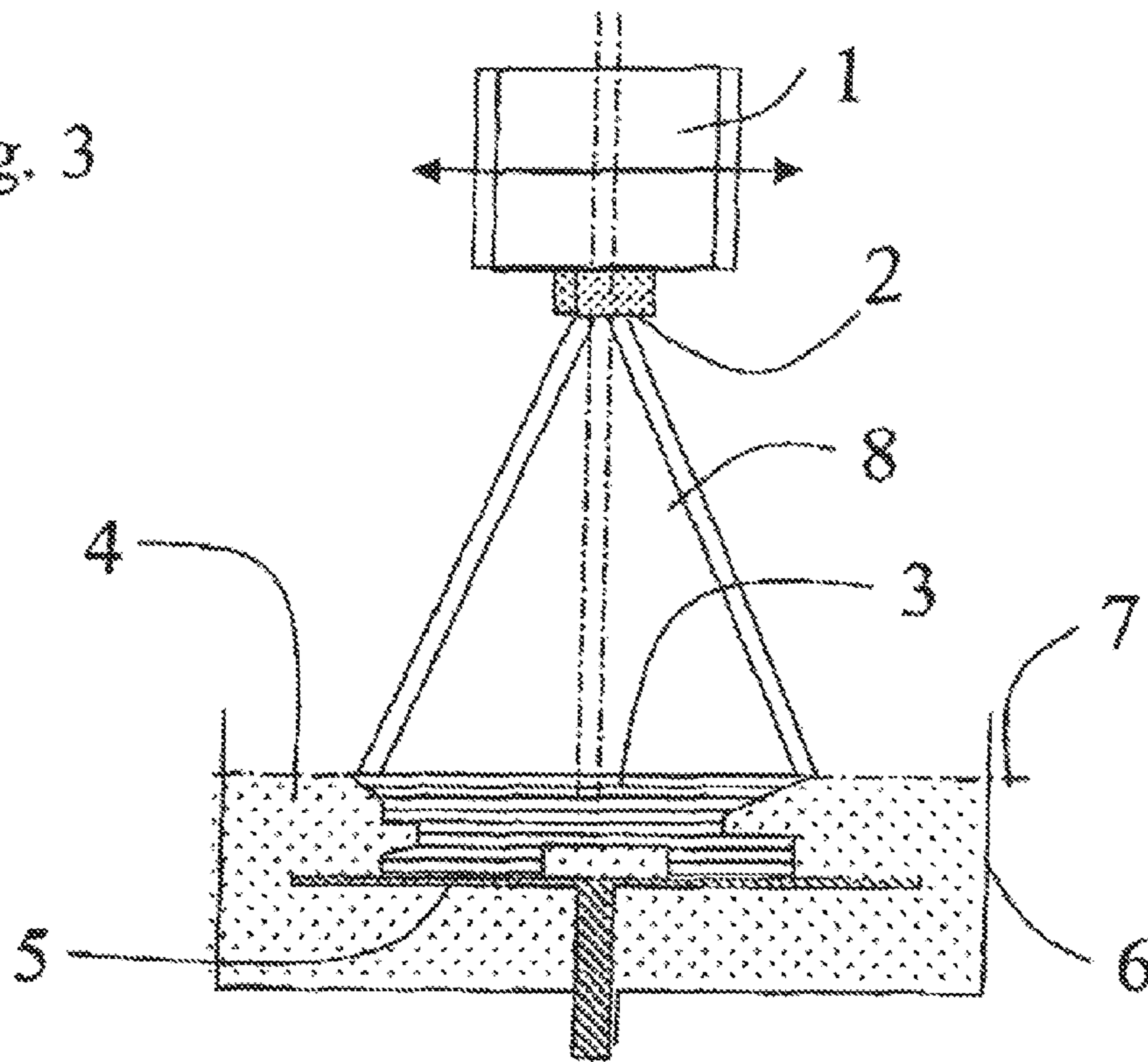

Fig. 4

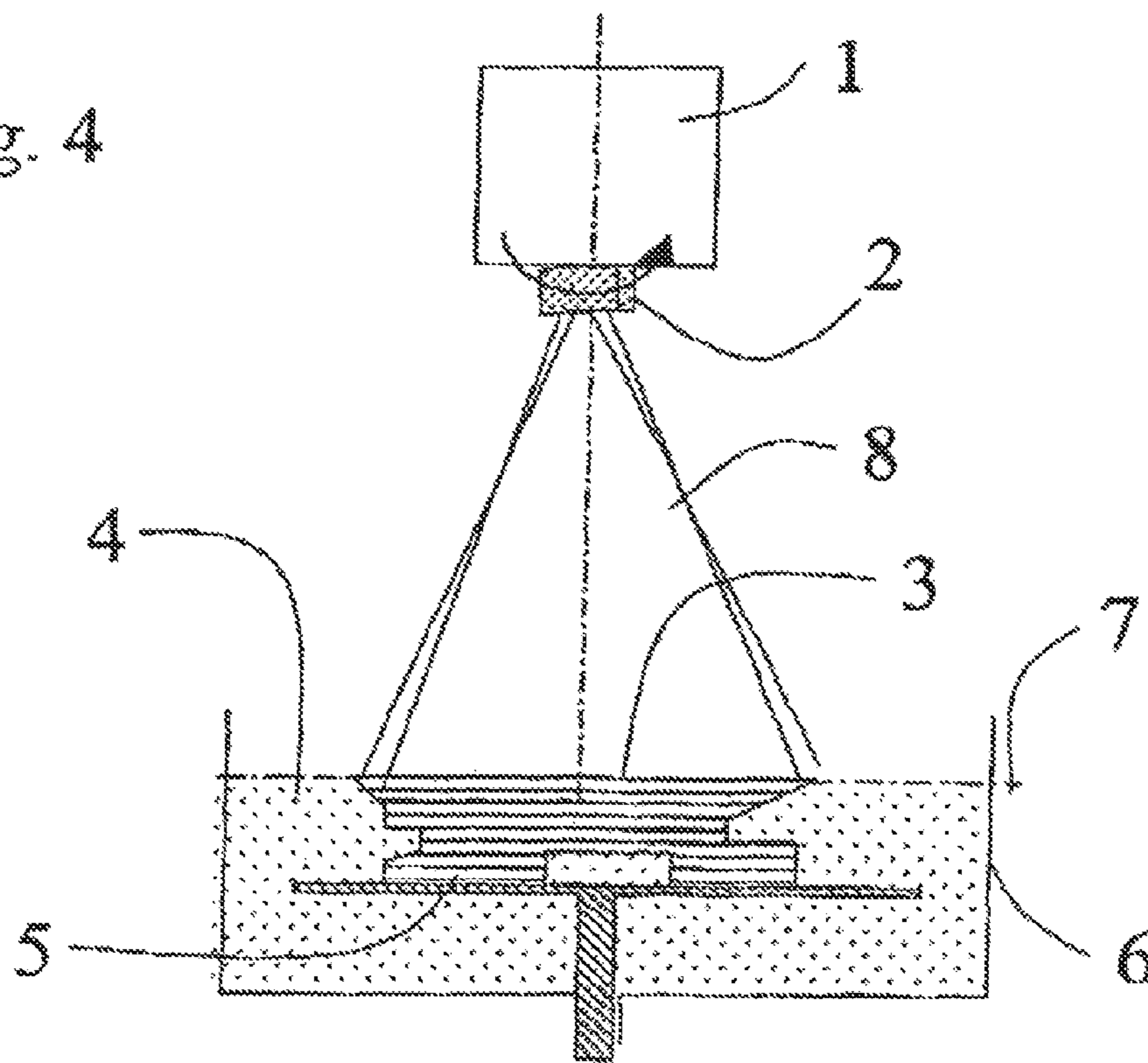

Fig. 5

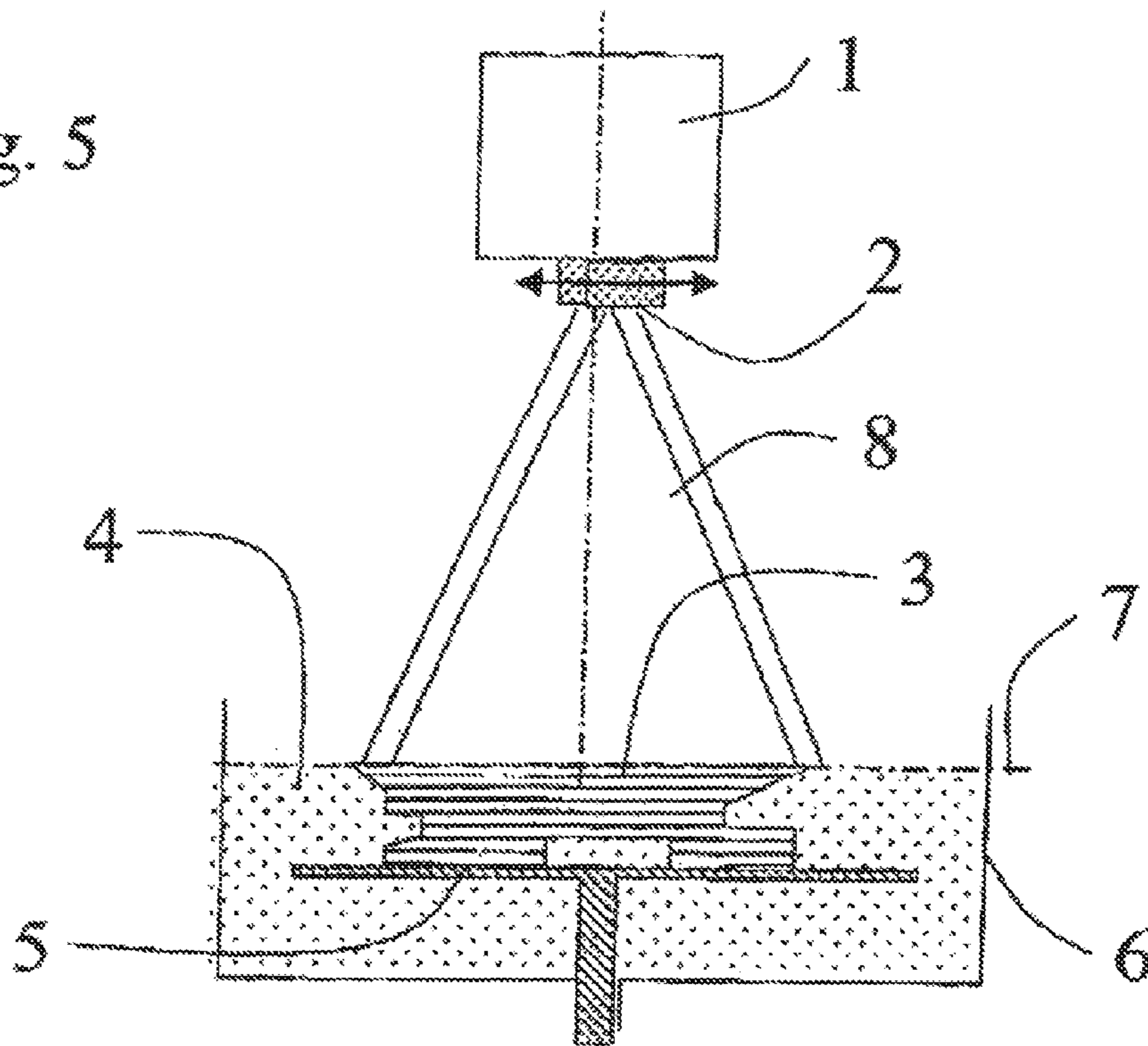
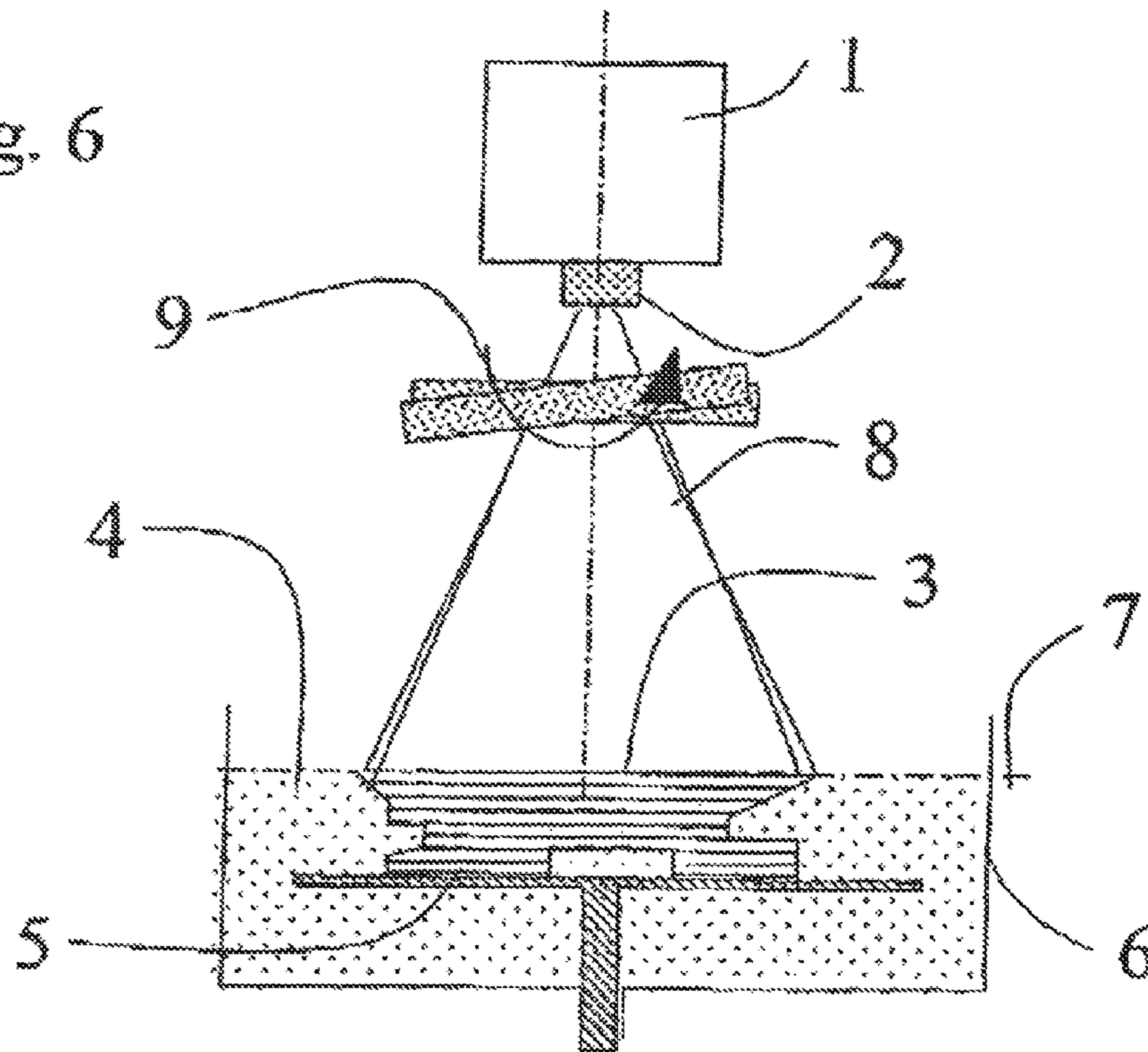
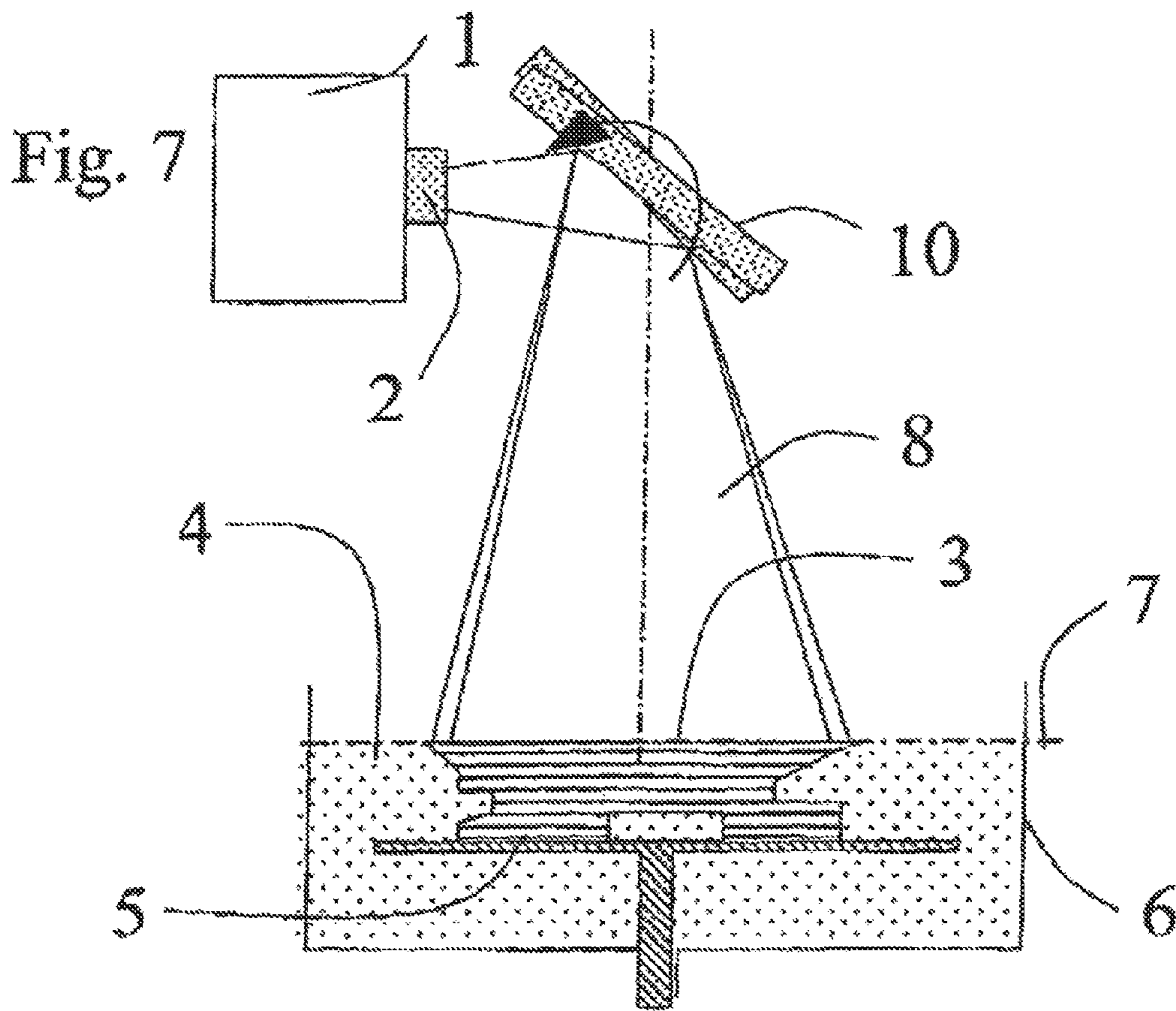
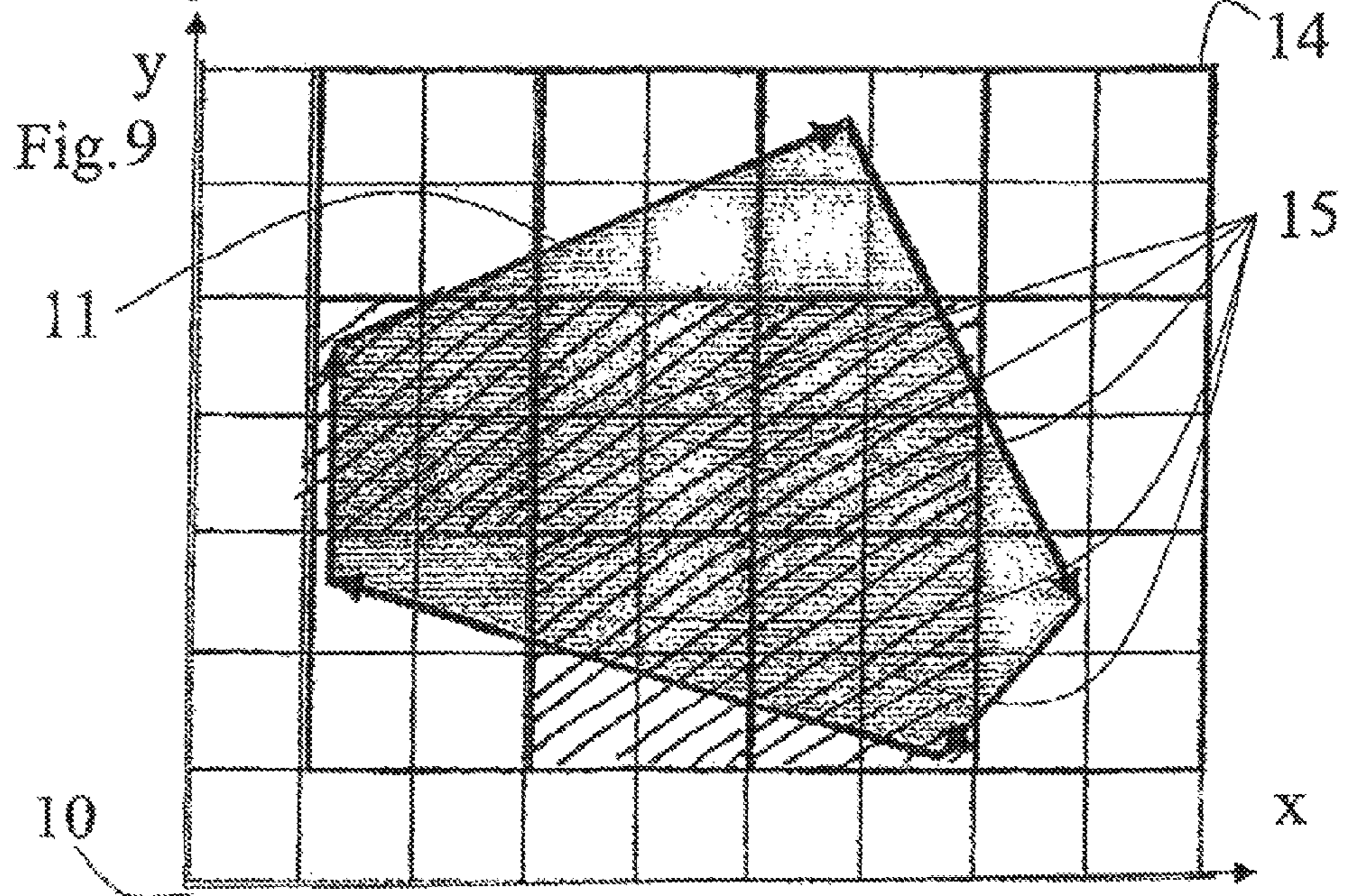
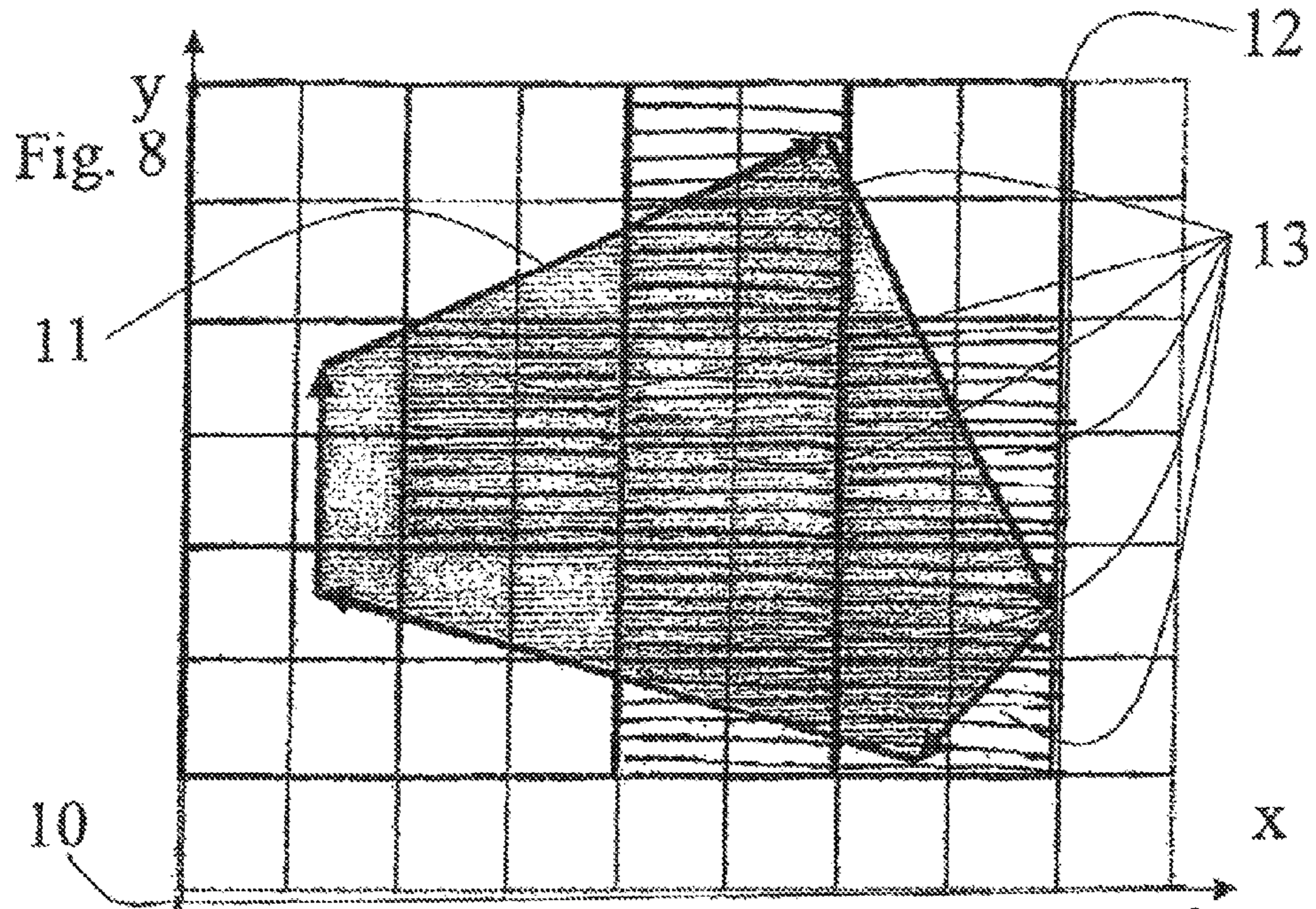

Fig. 6









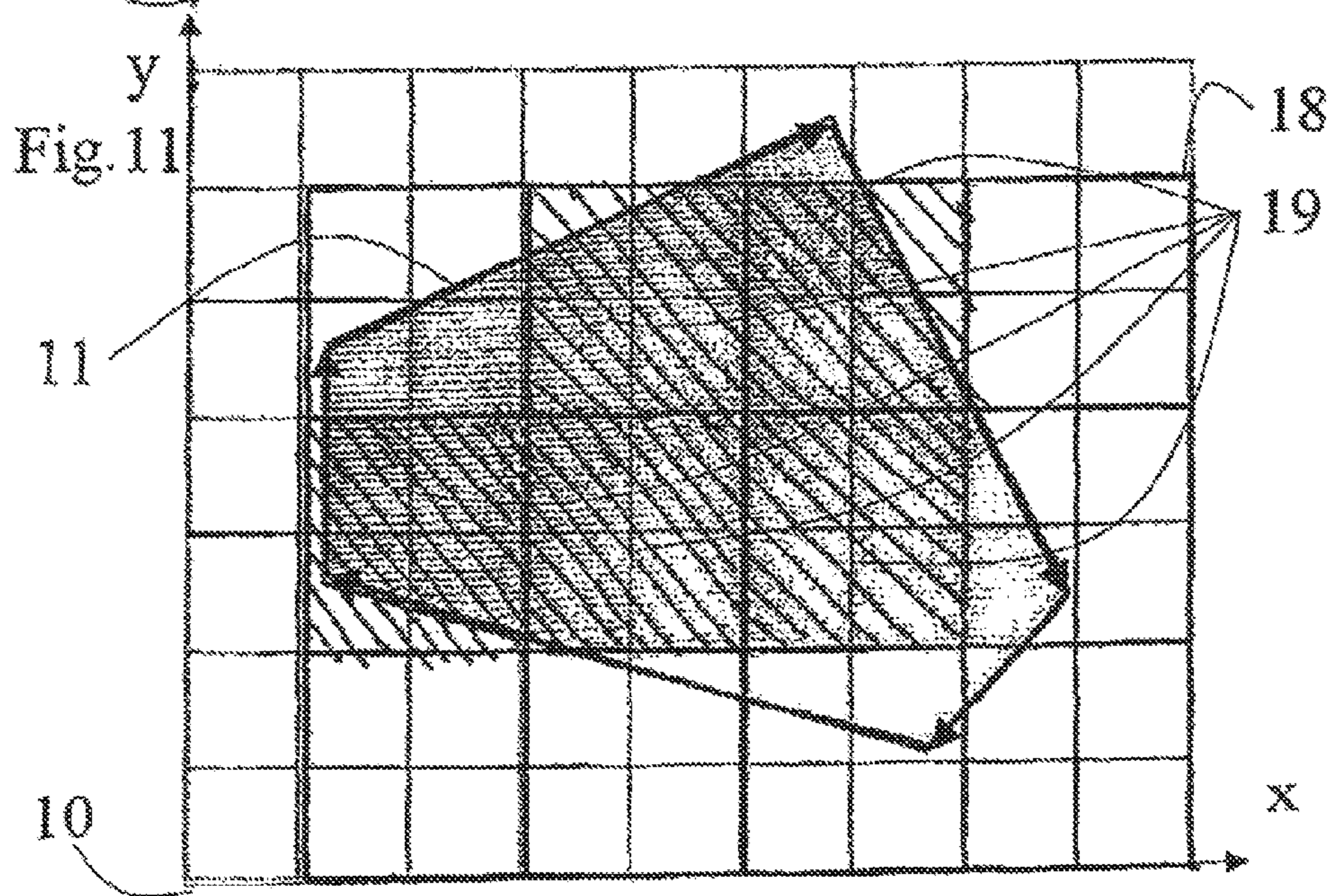
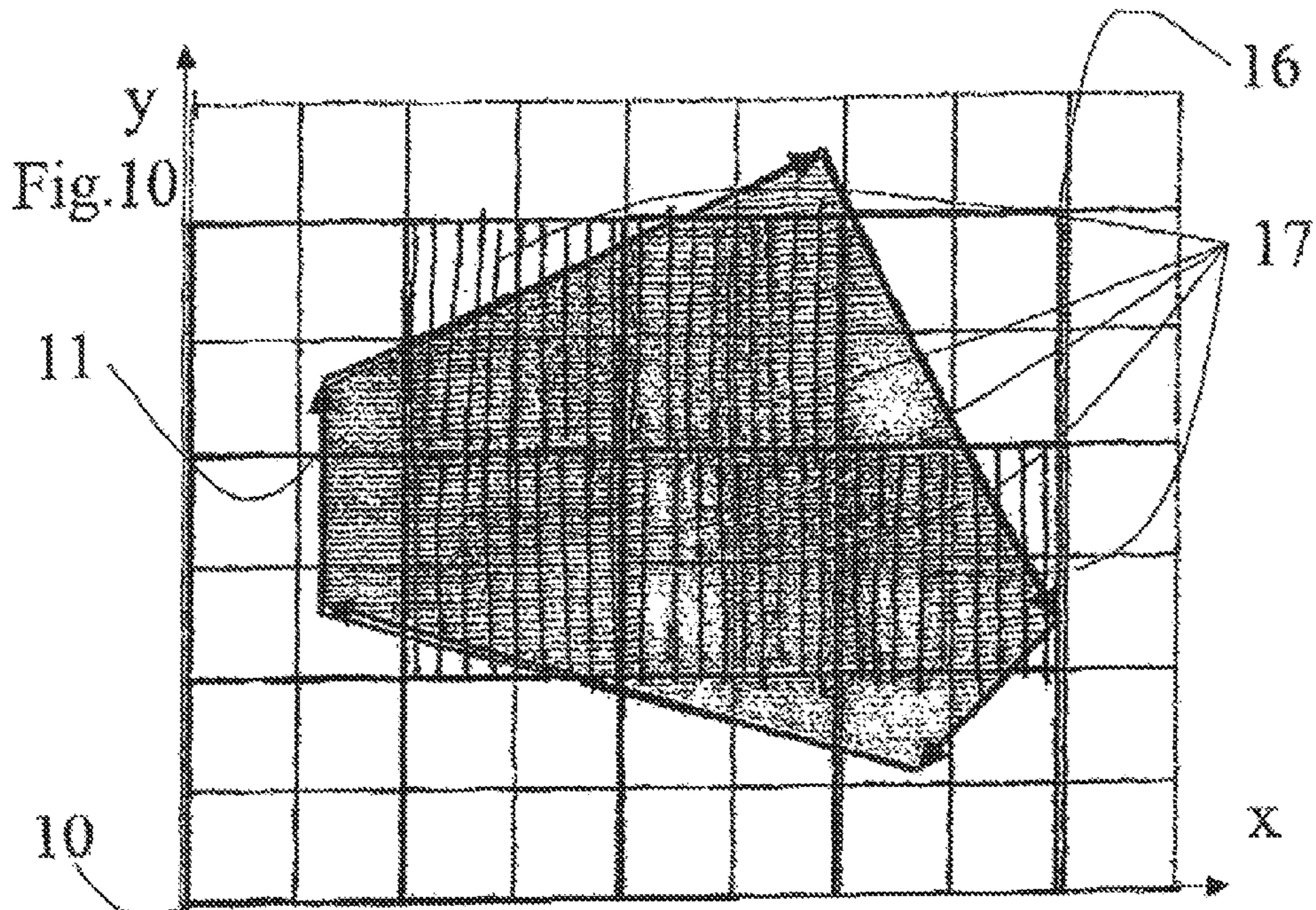

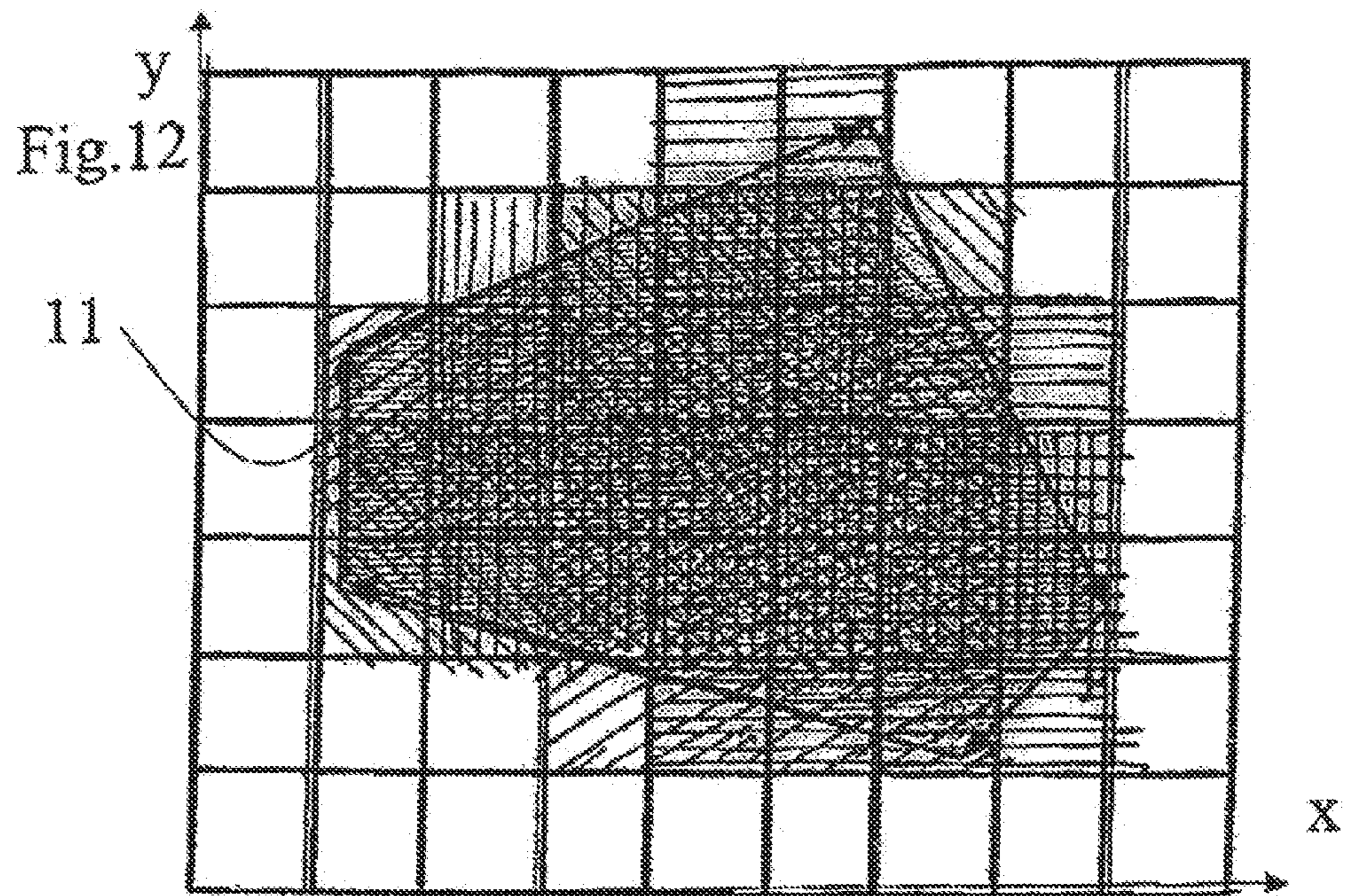

**PROCESS FOR THE PRODUCTION OF A  
THREE-DIMENSIONAL OBJECT WITH  
RESOLUTION IMPROVEMENT BY  
PIXEL-SHIFT**

**Matter enclosed in heavy brackets [ ] appears in the original patent but forms no part of this reissue specification; matter printed in italics indicates the additions made by reissue.**

*CROSS-REFERENCE TO RELATED  
APPLICATIONS*

*This application claims the benefit of U.S. Provisional Patent Application No. 60/569,893, filed on May 10, 2004.*

TECHNICAL FIELD

The invention related to a process and a device for the production of a three-dimensional object by layer-wise solidification of a photohardening material by mask illumination by means of a rastered image forming unit having constant resolution, wherein the resolution within the image/construction plane shall be improved in the sub-pixel range.

BACKGROUND ART

For the layer-wise construction of three-dimensional objects from "light hardening" materials, various processes are mentioned in literature, see in this respect "Automated Fabrication-Improving Productivity in Manufacturing" of Marshall Burns, 1993 (ISBN 0-13-119462-3).

This invention relates to processes wherein the layer to be generated is based on illumination by means of a rastered mask, wherein the smallest physical resolution within the mask is provided by the size of a pixel.

Known possibilities presently are, inter alia, illumination by

- a) Projection unit (on the basis of DLP®/DMD®, LCD, ILA®, etc.)
- b) LD-display (reflective, transmissive)
- c) LED-, or laser-diode-line/-matrix (which is moved in XY-plane over the layer)
- d) Line or matrix (which is moved in XY-plane over the layer) based on MEM-technology (light-valve).

Some of these methods are described in the following patents:

IPC: B29C67/00 "Rapid Prototyping apparatus and method of Rapid Prototyping" of Dicon AS (DK), (application) US patent US005247180 A "Stereolithographic Apparatus and Method of use" of Texas Instruments Inc., September 1993.

US patent US005980813 A "Rapid Prototyping using multiple materials" of SRI International, November 1999; Utility Model DE G 93 19 405.6 "Device for the production of a three-dimensional object (model) according to the principle of photosolidification" of Research Center Informatik at the University Karlsruhe, Dez. 1993;

An application for the generation of micro-technical, three-dimensional construction parts according to a similar process is described in the Utility Model DE 299 11 122 U1 "Device for the production of a three-dimensional object" DeltaMed et al., June 1999.

PCT Application 02 008 019.8 "Device for the production of a three-dimensional object" of Envision Technologies GmbH, April 2002.

U.S. Pat. No. 6,180,050 describes a linear scan technique for layer-wise solidification in the production of three-dimensional objects. The resolution is enhanced by scanning, in X-direction, an illumination head having an array of optical fibers, which are displaced in the Y-direction.

DRAWBACKS OF THE PRIOR ART

With all of the above described processes, the resolution of the material layer to be hardened is in direct dependency from the resolution of an image forming process.

With the projection processes, an intermediary positioned optic additionally determines the scale of the projected or solidifiable layer.

The resolution per area unit in the image/construction plane thus is dependent on a) the resolution of the image forming unit or the smallest element, called pixel, and their relative mutual distances, called pixel-pitch, and b) the projection scale.

The surface roughness of the construction part thus is determined by the smallest volume unit of one voxel (volume-pixel), the size of which is composed of the projected pixel area in XY and the layer thickness in Z. The resolution of the layer thickness is prescribed by the smallest resolution (step level) of the actuator in Z, in order to move the support platform. Resolutions already down to the one-figure  $\mu\text{m}$  range is achievable hereby. If an even lower surface roughness of the construction part shall be realized, the projection field and concurrently the width of the pixel area must be down-sized.

As an example, the projection m.H. of a multi-media projector shall be mentioned here; with a resolution of XGA (1024×768 image dots), a pixel of 17  $\mu\text{m}$  and pixel-pitch of 17.9  $\mu\text{m}$ , one realizes, at a projection to 275 mm×206 mm with an enhancement factor of the projection optic of 15, a resolution in the image/construction plane and thus in the layer to be solidified of approximately 100 dpi, which corresponds to a pixel size in the projection plane of about 0.254 mm×0.254 mm.

In order to e.g. double the resolution in the image-/construction plane, while maintaining the same construction area, it is proposed in the projection processes to half the projection/enhancement factor (which means to quarter the area) and, for the illumination of the four partial planes, to shift either the whole projection unit or the construction space mutually in parallel.

This process has the significant drawback that relatively high masses have to be moved towards each other very precisely in order to ensure an exact abutment and a close connection of the partial planes, which means a considerable expenditure of costs and additional need of space in the whole arrangement for the mechanics required therefore.

With the selective direct illumination by scanning m.H. of a LED- or laser-diode-line/-matrix or direct illumination by a mask, which is formed by a transmissive LCD, the resolution in the construction plane is equivalent to the resolution in the image forming unit.

OBJECT OF THE INVENTION

It is an object of the invention to provide a process or a device which can enhance the resolution in the construction plane, while maintaining the same large construction area, many times in the sub-pixel range, i.e. to refine the rastering of the outer and inner contours in the sectional planes of the object,

3

- a) without having to carry out an illumination in partial areas to be composed together, and
- b) without enhancing the resolution of the rastered image-forming unit itself.

## SOLUTION OF THE OBJECT

The present invention provides a process for the production of a three-dimensional object by layer-wise solidification of a material solidifiable by the action of electromagnetic irradiation by means of mask illumination, wherein the mask is produced by an image forming unit having a prescribed resolution, which mask is formed from a constant number of image forming elements (pixel) being discrete and spatially arranged in a fixed manner to each other, characterized in that, for improving the resolution in the sub-pixel range along the outer and inner contours of the sectional areas of the object to be generated layer-wise, a multiple illumination is carried out for each layer which consists of a sequence of a multitude of images mutually shifted in the sub-pixel range in the image/construction plane, wherein a separate mask/bitmap is produced for each shifted image.

The invention also provides a device for the production of a three-dimensional object by layer-wise solidification of a material which is solidifiable under the application of electromagnetic irradiation by means of mask illumination, whereby the irradiation necessary for hardening is imaged into the image/construction plane, wherein the device comprises a rastered, image forming unit for the selective illumination, which is embodied either by line or by matrix, characterized in that the image forming unit composes the image from individual image dots (pixels) and thus forms a rastered mask (bitmap), wherein the pixels are arranged within the plane in a manner mutually fixed to each other, and that the image forming unit and/or an imaging optic which is provided between the image forming unit and the image/construction plane is/are designed such that a sequence of a multitude of images, which are mutually shifted in a sub-pixel range, can be created, wherein a separate mask/bitmap can be produced for each shifted image.

Preferred embodiments of the process of the present invention include one or more of the following features:

- (a) said image forming unit is formed of a constant number of image forming elements (pixel) being discrete and spatially arranged to each other in a two-dimensional matrix;
- (b) a sequence of at least 2 images mutually shifted in the sub-pixel range is carried out in the image/construction plane, corresponding to the resolution of the image forming unit and under consideration of the corresponding sub-pixel shift;
- (c) the sectional area, i.e. outer and inner contours, are defined by vectorial trails which are superimposed by technical image processing by a rastered area (bitmap), the resolution of which exactly corresponds to the resolution of the discrete elements (pixels) in the image forming unit and thus in the image in the construction plane, wherein the superimposition of vectorial trails and bitmap takes place in a superior-ordered XY-coordinate system, and wherein the active pixels are calculated by a specific algorithm in order to define the sectional area in the form of a rastered mask;
- (d) the mask generation (bitmapping) of each sectional area of a three-dimensional object is carried out in the starting position and in various states displaced (shifted) in the sub-pixel range in XY, and that a total image having an

4

enhanced resolution in the contour portion corresponding to the pixel shift is obtained by the superimposition of these bitmaps per sectional area;

- (e) a bitmap is produced which is shifted relative to the sectional area by delta X, which results in a new distribution of active pixels;
- (f) a bitmap is produced which is shifted by delta Y in the sub-pixel range relatively to the sectional area, which results in a new distribution of active pixels;
- (g) a bitmap is produced which is shifted along the pixel diagonal by delta X and delta Y relatively to the sectional area, which results in a new distribution of active pixels;
- (h) the total illumination of an individual layer results from the sum of the partial illuminations of the masks/bitmaps shifted in the sub-pixel range;
- (i) for each layer of the object, a multitude of masks or bitmaps having different sub-pixel shifts in XY can be generated and can be illuminated serially for each layer to be hardened;
- (j) a simplified process for resolution improvement is achieved in such a manner that only the bitmap of the starting position and the bitmap of the diagonal-shift by a half pixel-diagonal are produced and are subsequently illuminated for each layer to be hardened;
- (k) for the shifted imaging of the rastered masks/bitmaps in the construction plane which are produced in a shifted manner in the sub-pixel range for the purpose of selectively hardening the material layer, the image forming unit is tilted for each shifted bitmap such that the desired shift of the image in the sub-pixel range in the image/construction plane is achieved;
- (l) for the shifted imaging of the rastered masks/bitmaps in the construction plane which are produced in a shifted manner in the sub-pixel range for the purpose of selectively hardening the material layer, the image forming unit for each shifted bitmap is shifted by the corresponding sub-pixel range in X and Y, that is parallel in plane to the image/construction plane;
- (m) for the shifted imaging of the rastered masks/bitmaps in the construction plane which are produced in a shifted manner in the sub-pixel range for the purpose of selectively hardening the material layer, the image forming projection unit is maintained fixed in its position, and the imaging optic of the projection unit is tilted for each shifted bitmap such that the desired shift of the image in the image/construction plane in the sub-pixel range is achieved;
- (n) for the shifted imaging of the rastered masks/bitmaps in the construction plane which are produced in a shifted manner in the sub-pixel range for the purpose of selectively hardening the material layer, the image forming projection unit is maintained fixed in its position, and the imaging optic of the projection unit is shifted for each shifted bitmap in XY such that the desired shift of the image in the image/construction plane in the sub-pixel range is achieved;
- (o) for the shifted imaging of the rastered masks/bitmaps in the construction plane which are produced in a shifted manner in the sub-pixel range for the purpose of selectively hardening the material layer, the projection unit is tilted for each bitmap via actuators such that the projected image in the construction plane is shifted in the corresponding sub-pixel range in X and Y;
- (p) for the shifted imaging of the rastered masks/bitmaps in the construction plane which are produced in a shifted manner in the sub-pixel range for the purpose of selectively hardening of the material layer, a cardanic mounted transparent, plane-parallel plate is arranged between the projec-

5

tion unit and the image/construction plane, which plate shifts, by rotation around two axis (XY) which are present in-plane parallel to the image/construction plane, the projection beam path and thus the image in the image/construction plane in the sub-pixel range in X and Y;

(q) for the shifted imaging of the rastered masks/bitmaps in the construction plane which are produced in a shifted manner in the sub-pixel range for the purpose of selectively hardening of the material layer, a transparent plane-parallel plate is arranged between the projection unit and the image/construction plane, which plate shifts, by rotation around an axis parallel to a pixel-diagonal, the projection beam path and thus the image in the image/construction plane in the sub-pixel range along the pixel diagonal which is orthogonal thereto;

(r) for the shifted imaging of the rastered masks/bitmaps in the construction plane which are produced in a shifted manner in the sub-pixel range for the purpose of selectively hardening of the material layer, the projection unit is maintained fixed in its position, and the projection beam is deflected via a mirror into the image/construction plane, wherein the deflecting mirror is provided with an adjustment possibility (cardanic support) by which the projection beam for each shifted bitmap can be deflected such that a shift of the image in the sub-pixel range is achieved in the image-/construction plane; and

(s) the projected light output for each pixel is varied by "grey scaling" within a projection mask, in order to selectively influence the hardening level in a layer thereby and thus to raise the light output of the contour-pixel relative to the light output of the area-pixel, in order to compensate the partial illumination due to partial superimposition of a contour-pixel by the sub-pixel shift of the individual bitmap in the contour portion.

Preferred embodiments of the device of the present invention include one or more of the following features:

(1) said image forming unit for the selective illumination is embodied by a matrix;

(2) a series of at least 2 images, which are mutually shifted in a sub-pixel range, can be created in the image/construction plane

(3) said image forming unit is a projection unit;

(4) said image forming unit is a line, particularly a matrix having discretely emitting elements for image formation;

(5) the device is provided with actuators in order to shift the whole image forming unit per partial image in a plane-parallel manner towards the image/construction plane in XY in the sub-pixel range;

(6) the device is provided with actuators which can tilt the image forming unit per shift-generated bitmap such that the individual, shift-generated bitmaps in the image/construction plane are imaged in a manner shifted in the sub-pixel range;

(7) between the image forming unit and the image/construction plane, a mirror is arranged as an imaging optic and is cardanically mounted and is rotatable via actuators such that the beam path is deflected into the image plane and that the individual, shift-generated bitmaps in the image-/construction plane can be imaged in a correspondingly shifted manner in the sub-pixel range;

(8) between the image forming unit and the image/construction plane, a transparent plate having mutual plane-parallel surfaces is arranged as an imaging optic and can be tilted by means of one or more actuators such that the beam path is shifted and that the individual, shift-generated bitmaps in the image-/construction plane are imaged in a manner shifted in the sub-pixel range;

6

(9) the image forming projection unit is maintained fixed in its position and that the imaging optic can be shifted in XY in a sub-pixel range of the image forming unit via actuators such that the desired shift of the image in the image-/construction plane in a sub-pixel range is achieved; and

(10) the image forming projection unit is maintained fixed in its position and that the imaging optic can be tilted via actuators such that the desired shift of the image in the image/construction plane in the sub-pixel range is achieved.

#### DESCRIPTION OF THE INVENTION AND ITS ADVANTAGES

By means of the process of the invention or the device of the invention, the resolution in the image/construction plane is improved in the sub-pixel range by means of "pixel-shift".

In particular, the present invention deals with the layer-wise solidification for the production of three-dimensional objects or construction elements by means of solidification of material (specifically by means of photo-polymerization) through mask projection, but not with a conventional layer-wise solidification through (linear) scan technique. This can be carried out according to the invention very efficiently and advantageously by using a two-dimensionally set array as the image generating element, wherein raster and/or resolution is(are) preset, e.g. by means of a set micro mirror array.

Compared to the scan technique, which is called VAROS (Variable Refraction Optical System) by Canon and "Double-CCD" by Epson, the principle of reading and overlapping of images mutually shifted in the sub-pixel range is used in this invention for rastered image forming processes of rapid prototyping.

The resolution or the number of image dots of the rastered, image forming unit itself does not have to be increased in order to realize an improvement in the solution within the construction plane.

For the enhancement of the resolution, the illumination does not occur in correspondingly down-sized, adjacently disposed partial areas, whereby the construction/illumination period for the whole area would be increased by the number of partial areas; rather, the projection/illumination occurs over the whole construction area.

By the measure that an overlapping of images that are mutually shifted in the sub-pixel range takes place, the construction/illumination period of the whole area increases only insubstantially.

The level of resolution improvement within the construction plane can be chosen freely.

#### DESCRIPTION OF THE DRAWINGS AND THE PREFERRED EMBODIMENTS OF THE INVENTION

The present invention will be explained in detail in the following by way of examples and not in a limiting manner by means of drawings.

FIG. 1 schematically shows a basic device for the generation of a three-dimensional object 3 by layer-wise hardening of a photohardening material 4 by means of mask projection 8, wherein the projection unit 1 is present, with an image forming optic 2, above the basin 6 which is filled with photohardening material 4, and wherein the object 3 solidifies layer-wise on a support plate 5, which can be moved within the basin 6 in vertical direction. In a process based on photohardening by means of mask illumination, the irradiation necessary for hardening is projected into the image/construction-

tion plane 7. The illumination is carried out by means of a rastered image forming unit, which is formed in the form of a matrix. The image thus is composed of single image dots (pixels) and thus forms a rastered mask (bitmap), wherein the pixels are arranged in a specially fixed manner to each other within the plane.

By a simple example, FIG. 8-12 show the principle of a mask generation (bitmapping) of a sectional area of a three-dimensional object in the starting position (FIG. 8) and in various states of the bitmap which are displaced (shifted) in the sub-pixel range (FIG. 9-11), as well as the overlapping of all bitmaps (FIG. 12).

The sectional area, i.e. the outer and inner contours, are prescribed by a sectorial trail 11, which is superimposed by a rastered area (bitmap) 12, the solution of which exactly corresponds to the resolution of the discrete elements (pixels) within the projected image 8 which is formed by the image forming matrix. Vectorial trail 11 and bitmap 12 thus exist within a superior-ordered XY-coordinate system 10. FIG. 8 shows the bitmap in its starting position. By means of a specific algorithm, the active pixels 13 which describe the sectional area within the bitmap 12 in its starting position are calculated.

In FIG. 9, the bitmap 14 is shifted within the sub-pixel range relative to the sectional area by delta X, whereby a new distribution of active pixels 15 is produced.

FIG. 10 shows a shift of bitmap 16 relative to the sectional area by delta Y with active pixels 17.

FIG. 11 shows a diagonal shift of bitmap 18 relative to the sectional area by delta X and delta Y with active pixels 19.

In FIG. 12, all bitmaps 12, 14, 16 and 18 with their active pixels 13, 15, 17 and 19 are shown superimposed, whereby a resolution improvement in the (outer) contour portion of the sectional area is clearly noticeable.

A simplified process for resolution improvement is achieved by the measure that only bitmap 12 of the started position (FIG. 8) and bitmap 18 of the diagonal shift (FIG. 11) are superimposed. In this case, the bitmap or the image does only have to be shifted in one direction along the diagonal of the pixels.

Depending on the resolution improvement desired for each object layer, a multiple (at least twice) of masks or bitmaps having different sub-pixel shifts can be generated and superimposed.

By means of a differently shifted and superimposed illumination of each object/material layer (here by means of bitmaps 12, 14, 16, 18), a resolution improvement in XY in the portion of outer and inner contours is achieved. In order to realize respective sub-pixel shifts in the image within the construction plane, the following various embodiments are described:

- 1) In FIG. 2, the image forming unit 1 is tilted for each shifted bitmap such that the desired shift of the image in the sub-pixel range within the image/construction plane is achieved.
- 2) In FIG. 3, the image forming unit 1 is shifted for each shifted bitmap by the corresponding sub-pixel level in X and Y, that is parallel in plane to the image/construction plane, by means of actuators.
- 3) In FIG. 4, the image forming projection unit is maintained fixed in its position, The imaging optic 2 is tilted for each shifted bitmap such that the desired shift of the image within the image-/construction plane in the sub-pixel range is achieved.
- 4) In FIG. 5, the image forming projection unit is maintained fixed in its position. The imaging optic 2 is moved for each

shifted bitmap in XY such that the desired shift of the image within the image-/construction plane in the sub-pixel range is achieved.

- 5) Particular cases for imaging by image-ward telecentric irradiation path, by an image-ward approximately telecentric irradiation path, and by teleobjectives having long focal length, in order to keep optical errors (angle errors, distortion) small:

a) In FIG. 5, the projection unit 1 is tilted for each shifted bitmap via actuators such that the projection image 8 within the image/construction plane 7 is shifted in the corresponding sub-pixel range in X and Y.

b) In FIG. 6, a cardanically mounted transparent, plane-parallel plate 9 (glass plate) is disposed between the protection unit 1 and the image/construction plane 7, which plate shifts the protection irradiation path 8 and thus the image within the image/construction plane 7 in the sub-pixel range in X and Y by means of rotation around two axis (XY), which are located parallel in plane to the image/construction plane.

c) In FIG. 7, the projection unit 1 is maintained fixed in its position. The projection beam 8 is deflected via a mirror 10 into the image/construction plane 7. The deflecting mirror 10 is provided with an adjustment possibility (cardanic support), by which the protection beam can be deflected for each shifted bitmap such that a shift of the image within the image/construction plane 7 in the sub-pixel range is achieved.

The embodiments 1) to 5) or a) to c) described above can be realized individually or combined with each other.

The bitmaps of each individual layer necessary for mask projection are generated from layer data, in which the outer and inner contours of the respective object section is represented in vectorial trails (as e.g. defined in the data format CLI).

For this, a specific SW is used which carries out the transformation of the vectorial trails into the bitmap format (bitmapping).

For each sub-pixel shift in XY, a separate bitmap is generated by transforming the XY coordinates of the vectors (for the outer and the inner contours) of the layer data by the respective shift-offset in XY (in the sub-pixel range), and by superposing them over the bitmap-raster, and thus by calculating a new distribution of active pixels for each shift.

The projected light output per pixel can be varied by "grey scaling" within a projection mask, in order to selectively influence the hardening level in one layer thereby. This is particularly meaningful in order to raise the light output of the pixels of the contour because only partial superimposition of the respective pixels of the contour are produced here due to the sub-pixel shift over individual bitmaps (in the areas within the contours a complete superimposition of the pixels of each individual bitmap is ensured).

When projecting/superimposing the section images shifted by sub-pixels, an almost homogeneous distribution of the light output or the illumination intensity can be achieved by means of the superimposition of grey scalings, particularly along the contours of the projected area structure, through the sum of the grey scaling masks.

The invention claimed is:

1. A process for the production of a three-dimensional object by layer-wise solidification of a material solidifiable by the action of electromagnetic irradiation by means of mask illumination, comprising: providing a projection unit for producing a mask having an image forming optic directed at a solidifiable material; producing a mask, wherein the mask is produced by an image forming unit having a prescribed reso-

lution, which mask is formed from a constant number of image forming elements (pixel) being discrete and spatially arranged in a fixed manner to each other, characterized in that, for improving the resolution in the sub-pixel range along the outer and inner contours of the sectional areas of the object to be generated layer-wise, a multiple illumination is carried out for each layer which consists of a sequence of a multitude of images mutually shifted in the sub-pixel range in the image/construction plane, wherein a separate mask/bitmap is produced for each shifted image.

2. The process according to claim 1, characterized in that said image forming unit is formed of a constant number of image forming elements (pixel) being discrete and spatially arranged to each other in a two-dimensional matrix.

3. The process according to claim 1, characterized in that a sequence of at least 2 images mutually shifted in the sub-pixel range is carried out in the image/construction plane, corresponding to the resolution of the image forming unit and under consideration of the corresponding sub-pixel shift.

4. The process according to claim 1 for the generation of the bitmap from a sectional area of a three-dimensional object, characterized in that the sectional area, i.e. outer and inner contours, are defined by vector paths which are superimposed by technical image processing by a rastered area (bitmap), the resolution of which exactly corresponds to the resolution of the discrete elements (pixels) in the image forming unit and thus in the image in the construction plane, wherein the superimposition of vector paths and bitmap takes place in a superior-ordered XY-coordinate system, and wherein the active pixels are calculated by a specific algorithm in order to define the sectional area in the form of a rastered mask.

5. The process according to claim 1, characterized in that the mask generation (bitmapping) of each sectional area of a three-dimensional object is carried out in the starting position and in various states displaced (shifted) in the sub-pixel range in XY, and that a total image having an enhanced resolution in the contour portion corresponding to the pixel shift is obtained by the superimposition of these bitmaps per sectional area.

6. The process according to claim 1, characterized in that a bitmap is produced which is shifted relative to the sectional area by delta X, which results in a new distribution of active pixels.

7. The process according to claim 1, characterized in that a bitmap is produced which is shifted by delta Y in the sub-pixel range relatively to the sectional area, which results in a new distribution of active pixels.

8. The process according to claim 1, characterized in that a bitmap is produced which is shifted along the pixel diagonal by delta X and delta Y relatively to the sectional area, which results in a new distribution of active pixels.

9. The process according to claim 1, characterized in that the total illumination of an individual layer results from the sum of the partial illuminations of the masks/bitmaps shifted in the sub-pixel range.

10. The process according to claim 1, wherein, for each layer of the object, a multitude of masks or bitmaps having different sub-pixel shifts in XY can be generated and can be illuminated serially for each layer to be hardened.

11. The process according to claim 1, characterized in that a simplified process for resolution improvement is achieved in such a manner that only the bitmap of the starting position and the bitmap of the diagonal-shift by a half pixel-diagonal are produced and are subsequently illuminated for each layer to be hardened.

12. The process according to claim 1, characterized in that, for the shifted imaging of the rastered masks/bitmaps in the construction plane which are produced in a shifted manner in the sub-pixel range for the purpose of selectively hardening the material layer, the image forming unit is tilted for each shifted bitmap such that the desired shift of the image in the sub-pixel range in the image/construction plane is achieved.

13. The process according to claim 1, characterized in that, for the shifted imaging of the rastered masks/bitmaps in the construction plane which are produced in a shifted manner in the sub-pixel range for the purpose of selectively hardening the material layer, the image forming unit for each shifted bitmap is shifted by the corresponding sub-pixel range in X and Y, that is parallel in plane to the image/construction plane.

14. The process according to claim 1, characterized in that, for the shifted imaging of the rastered masks/bitmaps in the construction plane which are produced in a shifted manner in the sub-pixel range for the purpose of selectively hardening the material layer, the image forming projection unit is maintained fixed in its position, and the imaging optic of the projection unit is tilted for each shifted bitmap such that the desired shift of the image in the image/construction plane in the sub-pixel range is achieved.

15. The process according to claim 1, characterized in that, for the shifted imaging of the rastered masks/bitmaps in the construction plane which are produced in a shifted manner in the sub-pixel range for the purpose of selectively hardening the material layer, the image forming projection unit is maintained fixed in its position, and the imaging optic of the projection unit is shifted for each shifted bitmap in XY such that the desired shift of the image in the image/construction plane in the sub-pixel range is achieved.

16. The process according to claim 1, characterized in that, for the shifted imaging of the rastered masks/bitmaps in the construction plane which are produced in a shifted manner in the sub-pixel range for the purpose of selectively hardening the material layer, the projection unit is tilted for each bitmap via actuators such that the projected image in the construction plane is shifted in the corresponding sub-pixel range in X and Y.

17. The process according to claim 1, characterized in that, for the shifted imaging of the rastered masks/bitmaps in the construction plane which are produced in a shifted manner in the sub-pixel range for the purpose of selectively hardening of the material layer, a cardanic mounted transparent, plane-parallel plate is arranged between the projection unit and the image/construction plane, which plate shifts, by rotation around two axis (XY) which are present in-plane parallel to the image/construction plane, the projection beam path and thus the image in the image/construction plane in the sub-pixel range in X and Y.

18. The process according to claim 1, characterized in that, for the shifted imaging of the rastered masks/bitmaps in the construction plane which are produced in a shifted manner in the sub-pixel range for the purpose of selectively hardening of the material layer, a transparent plane-parallel plate is arranged between the projection unit and the image/construction plane, which plate shifts, by rotation around an axis parallel to a pixel-diagonal, the projection beam path and thus the image in the image/construction plane in the sub-pixel range along the pixel diagonal which is orthogonal thereto.

19. The process according to claim 1, characterized in that, for the shifted imaging of the rastered masks/bitmaps in the construction plane which are produced in a shifted manner in the sub-pixel range for the purpose of selectively hardening of the material layer, the projection unit is maintained fixed in its position, and the projection beam is deflected via a mirror into

## 11

the image/construction plane, wherein the deflecting mirror is provided with an adjustment possibility (cardanic support) by which the projection beam for each shifted bitmap can be deflected such that a shift of the image in the sub-pixel range is achieved in the image-/construction plane.

20. The process according to claim 1, characterized in that the projected light output for each pixel is varied by "grey scaling" within a projection mask, in order to selectively influence the hardening level in a layer thereby and thus to raise the light output of the contour-pixel relative to the light output of the area-pixel, in order to compensate the partial illumination due to partial superimposition of a contour-pixel by the sub-pixel shift of the individual bitmap in the contour portion.

21. The process of claim 1, wherein each image that is mutually shifted in the subpixel range defines a degree of overlap between the object and each pixel and the multiple illumination step comprises projecting the electromagnetic radiation onto the solidifiable material based on each degree of overlap for each pixel and each mutually shifted image.

22. The process of claim 1, wherein each image in the multitude of images corresponds to a different bitmap location relative to a fixed coordinate system.

23. The process of claim 1, wherein the image forming unit includes an image forming matrix, and the multiple illumination of each object layer comprises:

- providing an image of the object layer;
- defining a bitmap, wherein the bitmap has a plurality of grid elements and each grid element corresponds to a location in the image forming unit;

## 12

superimposing the layer image on the bitmap to define a first relative orientation between the layer image and the bitmap;

calculating a first degree of overlap between each grid element and the layer image when the bitmap is in the first relative orientation;

shifting the bitmap relative to the layer image to define a second relative orientation between the layer image and the bitmap;

calculating a second degree of overlap between each grid element and the layer image when the layer image is in the second relative orientation; and

projecting electromagnetic radiation onto the curable resin based on the first degree of overlap and the second degree of overlap for each grid element.

24. The process of claim 23, wherein the step of projecting electromagnetic radiation onto the curable resin comprises first projecting electromagnetic radiation onto the curable resin such that each location in the image forming unit matrix projects electromagnetic radiation having an intensity that corresponds to the first degree of overlap for the bitmap grid element that corresponds to the image forming unit matrix location and second projecting electromagnetic radiation onto the curable resin such that each location in the image forming unit matrix projects electromagnetic radiation having an intensity that corresponds to the second degree of overlap for the bitmap grid element that corresponds to the image forming unit matrix location.

\* \* \* \* \*



UNITED STATES PATENT AND TRADEMARK OFFICE  
**CERTIFICATE OF CORRECTION**

PATENT NO. : RE43,955 E  
APPLICATION NO. : 13/230270  
DATED : February 5, 2013  
INVENTOR(S) : Shkolnik

Page 1 of 2

It is certified that error appears in the above-identified patent and that said Letters Patent is hereby corrected as shown below:

Please delete the title page and insert the new title page with deleting "El-Sibiani" and inserting --El-Siblani-- as shown on the attached page

Signed and Sealed this  
Twenty-sixth Day of February, 2013



Teresa Stanek Rea  
*Acting Director of the United States Patent and Trademark Office*

(19) **United States**  
 (12) **Reissued Patent**  
**Shkolnik et al.**

(10) **Patent Number:** **US RE43,955 E**  
 (45) **Date of Reissued Patent:** **Feb. 5, 2013**

(54) **PROCESS FOR THE PRODUCTION OF A THREE-DIMENSIONAL OBJECT WITH RESOLUTION IMPROVEMENT BY PIXEL-SHIFT**

4,999,143 A 3/1991 Hull et al.  
 5,093,130 A 3/1992 Fujii et al.  
 5,137,662 A 8/1992 Hull et al.  
 5,143,663 A 9/1992 Leyden et al.  
 5,173,266 A 12/1992 Kenney  
 5,174,931 A 12/1992 Almquist et al.  
 5,236,637 A 8/1993 Hull

(75) Inventors: **Alexandr Shkolnik**, Los Angeles, CA (US); **Hendrik John Hunxe** (DE); **All El-Siblani**, Dearborn Heights, MI (US)

(Continued)

(73) Assignee: **Envisiontec GmbH**, Gladbeck (DE)

**FOREIGN PATENT DOCUMENTS**

DE 4105314 A1 8/1991  
 DE 4102257 A1 7/1992

(21) Appl. No.: **13/230,270**

(Continued)

(22) Filed: **Sep. 12, 2011**

**OTHER PUBLICATIONS**

**Related U.S. Patent Documents**

Opposition to EP 1,849,587, dated Apr. 8, 2010

Reissue of:

(Continued)

(64) Patent No.: **7,790,093**  
 Issued: **Sep. 7, 2010**  
 Appl. No.: **11/126,068**  
 Filed: **May 9, 2005**

*Primary Examiner* Joseph Del Sole  
*Assistant Examiner* Kimberly A Stewart  
 (74) *Attorney, Agent, or Firm* Hansen IP Law PLLC

U.S. Applications:

(60) Provisional application No. 60/569,893, filed on May 10, 2004.

(57) **ABSTRACT**

(30) **Foreign Application Priority Data**

May 10, 2004 (DE) ..... 10 2004 022 961

The invention relates to a process or a device for the production of a three-dimensional object by layer-wise solidification of a material which is solidifiable under the application of electromagnetic irradiation by means of mask illumination, wherein the mask is produced using an image forming unit having a prescribed resolution, which is formed from a constant number of image forming elements (pixels) being discrete and being arranged in a spatially mutually fixed manner. For the improvement of the resolution along the outer and inner contours of the sectional areas of the object to be generated layer-wise in the sub-pixel range, a multiple illumination per layer is performed, which consists of a series of multiple images that are mutually shifted in the sub-pixel range in the image/construction plane, wherein a separate mask/bitmap is produced for each shifted image.

(51) **Int. Cl.**  
**G02F 1/00** (2006.01)  
 (52) **U.S. Cl.** ..... 264/401; 700/120; 264/497  
 (58) **Field of Classification Search** ..... 264/401, 264/497; 700/120  
 See application file for complete search history.

(56) **References Cited**

**U.S. PATENT DOCUMENTS**

4,575,330 A 3/1986 Hull  
 4,837,379 A 6/1989 Weinberg  
 4,929,402 A 5/1990 Hull

**24 Claims, 7 Drawing Sheets**

