



US00RE43920E

(19) **United States**
(12) **Reissued Patent**
Giddens

(10) **Patent Number:** **US RE43,920 E**
(45) **Date of Reissued Patent:** **Jan. 15, 2013**

(54) **PORTION OF A RECOIL COVER FOR AN INTERNAL COMBUSTION ENGINE**
(75) Inventor: **Keith B. Giddens**, Travelers Rest, SC (US)
(73) Assignee: **Liquid Combustion Technology LLC**, Travelers Rest, SC (US)
(21) Appl. No.: **29/316,068**
(22) Filed: **Aug. 20, 2009**
Related U.S. Patent Documents

Reissue of:
(64) Patent No.: **Des. 549,241**
Issued: **Aug. 21, 2007**
Appl. No.: **29/211,157**
Filed: **Aug. 11, 2004**
(51) **LOC (9) Cl.** **15-01**
(52) **U.S. Cl.** **D15/5**
(58) **Field of Classification Search** D15/1-5;
123/41.7, 50 A, 50 R, 50 B, 198 E, 65 R,
123/51 R, 657; 74/6; 474/8
See application file for complete search history.

(56) **References Cited**
U.S. PATENT DOCUMENTS
D257,844 S 1/1981 Stevens
(Continued)

OTHER PUBLICATIONS
U.S. Appl. No. 29/199,532 entitled *Portion of an Engine*; In re: Giddens; filed Feb. 16, 2004.
(Continued)

Primary Examiner — Sandra Snapp
(74) *Attorney, Agent, or Firm* — J. Bennett Mullinax, LLC

(57) **CLAIM**
The ornamental design for a portion of a recoil cover for an internal combustion engine, as shown and described.

DESCRIPTION

FIG. 1 is a perspective view of a portion of a recoil cover for an internal combustion engine according to [an] *first* embodiment of the present design;

FIG. 2 is a front elevation view of the portion of a recoil cover for [an] *the* internal combustion engine shown in FIG. 1; FIG. 3 is a top plan view of the portion of a recoil cover for [an] *the* internal combustion engine shown in FIG. 1; FIG. 4 is a bottom plan view of the portion of a recoil cover for [an] *the* internal combustion engine shown in FIG. 1; FIG. 5 is a right side elevation view of the portion of a recoil cover for [an] *the* internal combustion engine shown in FIG. 1; [and,] FIG. 6 is a left side elevation view of the portion of a recoil cover for [an] *the* internal combustion engine shown in FIG. 1[.]; FIG. 7 is a perspective view of a portion of a recoil cover for an internal combustion engine according to a second embodiment of the present design; FIG. 8 is a front elevation view of the portion of a recoil cover for the internal combustion engine shown in FIG. 7; FIG. 9 is a top plan view of the portion of a recoil cover for the internal combustion engine shown in FIG. 7; FIG. 10 is a bottom plan view of the portion of a recoil cover for the internal combustion engine shown in FIG. 7; FIG. 11 is a right side elevation view of the portion of a recoil cover for the internal combustion engine shown in FIG. 7; FIG. 12 is a left side elevation view of the portion of a recoil cover for the internal combustion engine shown in FIG. 7; FIG. 13 is a perspective view of a portion of a recoil cover for an internal combustion engine according to a third embodiment of the present design; FIG. 14 is a front elevation view of the portion of a recoil cover for the internal combustion engine shown in FIG. 13; FIG. 15 is a top plan view of the portion of a recoil cover for the internal combustion engine shown in FIG. 13; FIG. 16 is a bottom plan view of the portion of a recoil cover for the internal combustion engine shown in FIG. 13; FIG. 17 is a right side elevation view of the portion of a recoil cover for the internal combustion engine shown in FIG. 13; and FIG. 18 is a left side elevation view of the portion of a recoil cover for the internal combustion engine shown in FIG. 13. The broken lines shown in FIGS. 1-[6] 18 are for illustrative purposes only and form no part of the claimed design.

1 Claim, 12 Drawing Sheets

Matter enclosed in heavy brackets [] appears in the original patent but forms no part of this reissue; matter printed in italics indicates the additions made by reissue.

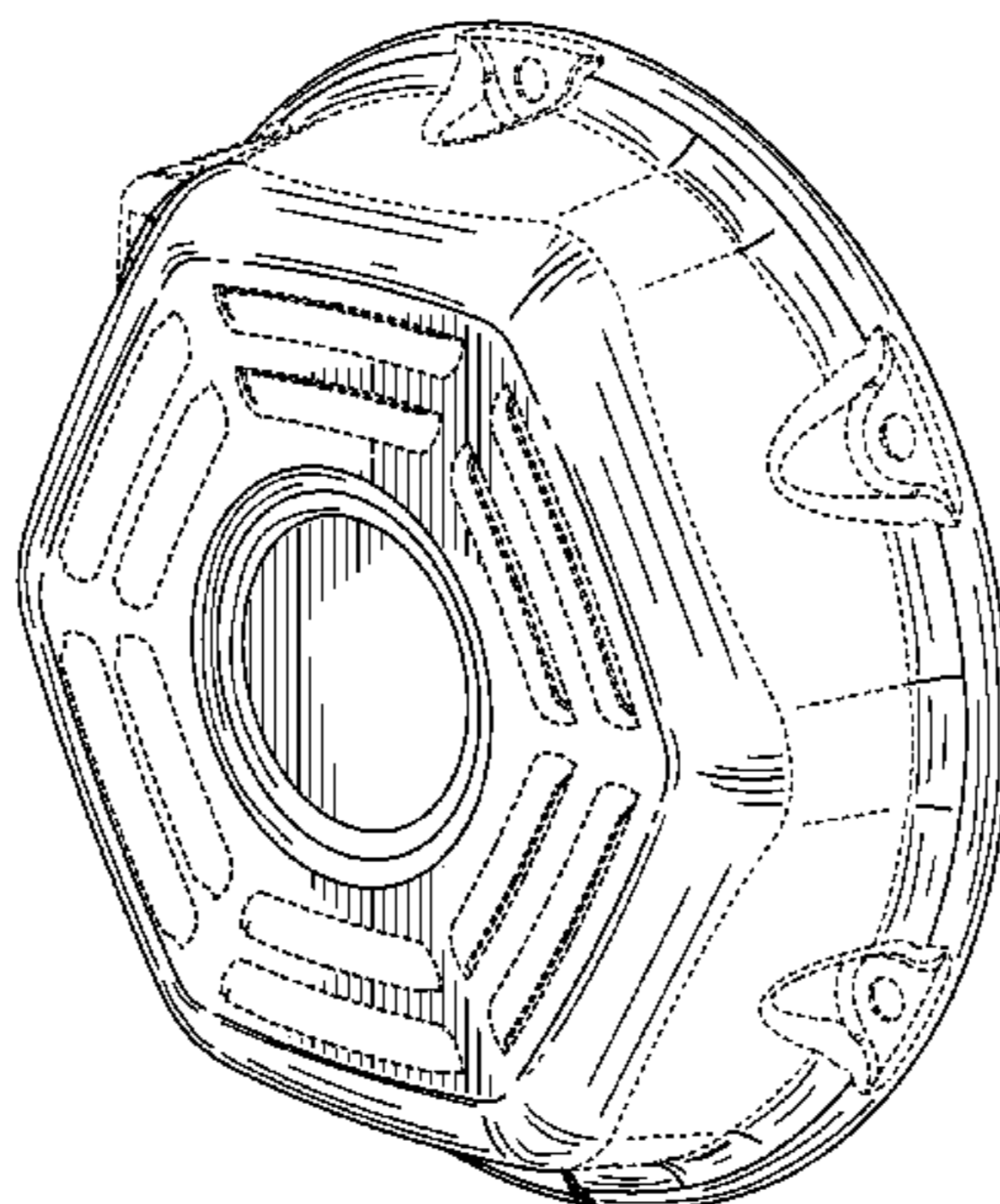

US RE43,920 E

Page 2

U.S. PATENT DOCUMENTS

D282,071 S 1/1986 Nakamura
D294,832 S 3/1988 Itou et al.
4,813,385 A 3/1989 Yamaguchi et al.
D305,432 S 1/1990 Hashigaki
D307,147 S 4/1990 Sasaki et al.
D307,148 S 4/1990 Mikado
D308,871 S 6/1990 Harkness et al.
D308,872 S 6/1990 Harkness et al.
D309,457 S 7/1990 Eifert et al.
D309,458 S 7/1990 Johnson et al.
5,072,627 A 12/1991 Horiye et al.
D330,897 S 11/1992 Carlson et al.
D331,929 S 12/1992 Leaf et al.
5,197,426 A 3/1993 Frangesch et al.
D342,076 S 12/1993 Heismann
D343,843 S 2/1994 Mikado
D353,381 S 12/1994 Yoshida et al.
D367,070 S 2/1996 Maeda et al.
D392,647 S 3/1998 Ueda et al.
D396,045 S 7/1998 Neeley
D396,476 S 7/1998 Shimizu
D397,342 S 8/1998 Shimizu
D398,010 S 9/1998 Yoshida et al.
D414,498 S 9/1999 Yoshida
D417,675 S 12/1999 Yaguchi et al.
D441,714 S 5/2001 Yuzuriha
D443,280 S 6/2001 Shimizu
6,240,889 B1 6/2001 Kuwabara et al.
D444,478 S 7/2001 Shimizu
D449,051 S 10/2001 Miyashita
6,331,740 B1 12/2001 Morohoshi et al.
6,362,533 B1 3/2002 Morohoshi et al.

D457,891 S 5/2002 Matre
D462,363 S 9/2002 Burmeister et al.
6,489,690 B1 12/2002 Hatsugai et al.
D468,751 S 1/2003 Neeley et al.
6,520,141 B2 2/2003 Ryczek et al.
6,525,430 B1 2/2003 Asai et al.
D471,207 S 3/2003 Kern et al.
D474,783 S 5/2003 Momoi
D475,065 S 5/2003 Shimizu et al.
D478,042 S 8/2003 Yaguchi et al.
D481,042 S 10/2003 Yuzuriha et al.
D481,043 S 10/2003 Yuzuriha et al.
D488,167 S 4/2004 Momoi
D491,193 S 6/2004 Davis
D503,722 S 4/2005 Stenz et al.
D503,723 S 4/2005 Giddens
D521,024 S 5/2006 Giddens
D532,794 S 11/2006 Glass
D539,818 S * 4/2007 Giddens D15/5
D549,241 S * 8/2007 Giddens D15/5
2001/0039845 A1 11/2001 Tachibana
2003/0154934 A1 8/2003 Nakamizo et al.
2003/0182823 A1 10/2003 Sanders et al.
2004/0224806 A1 11/2004 Chonan

OTHER PUBLICATIONS

U.S. Appl. No. 29/199,533 entitled *Portion of an Engine*; In re: Giddens; filed Feb. 16, 2004.

U.S. Appl. No. 29/211,389; entitled *Portion of an Internal Combustion Engine*; In re: Glass; filed Feb. 16, 2004.

* cited by examiner

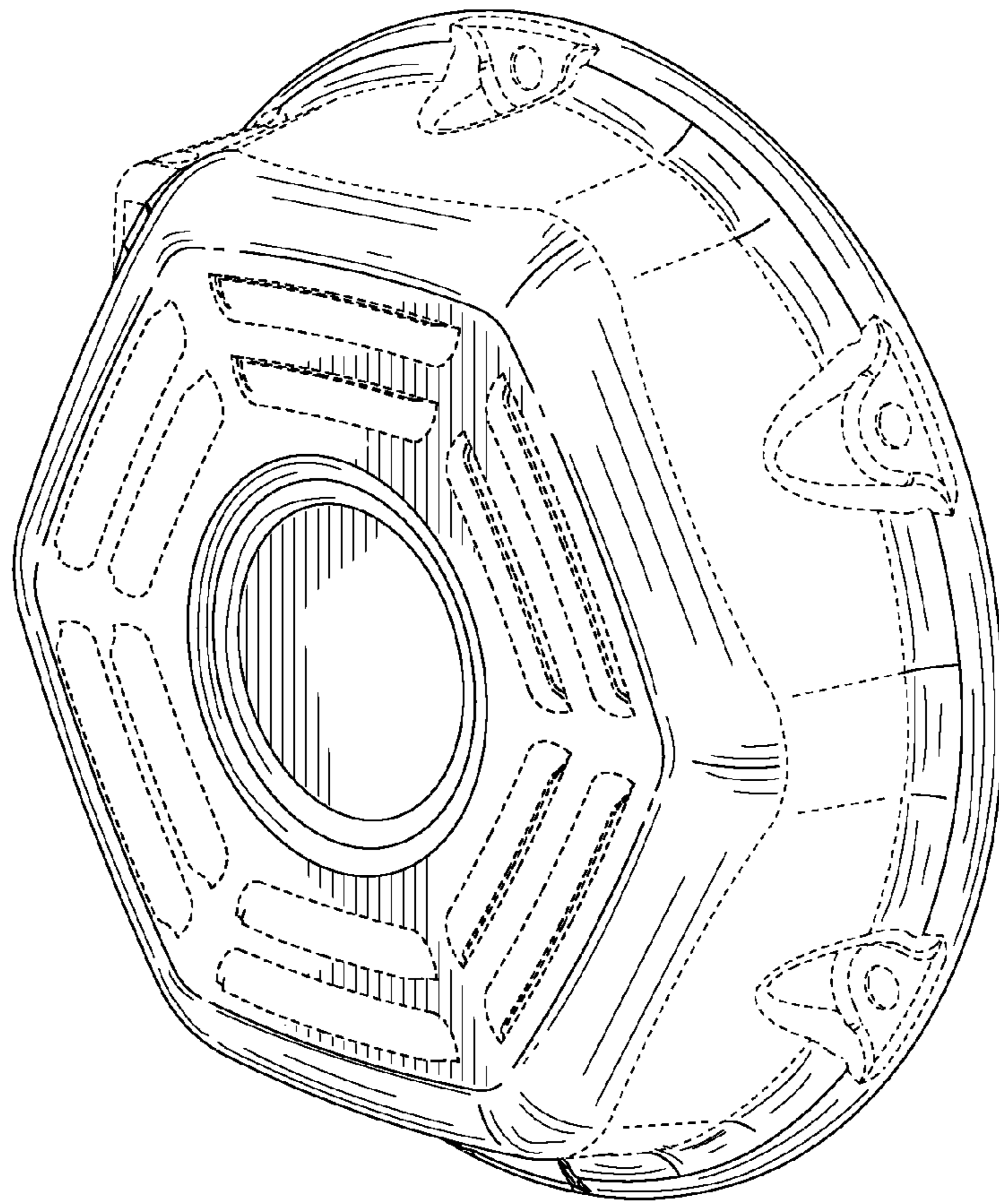

FIG. 1
AMENDED

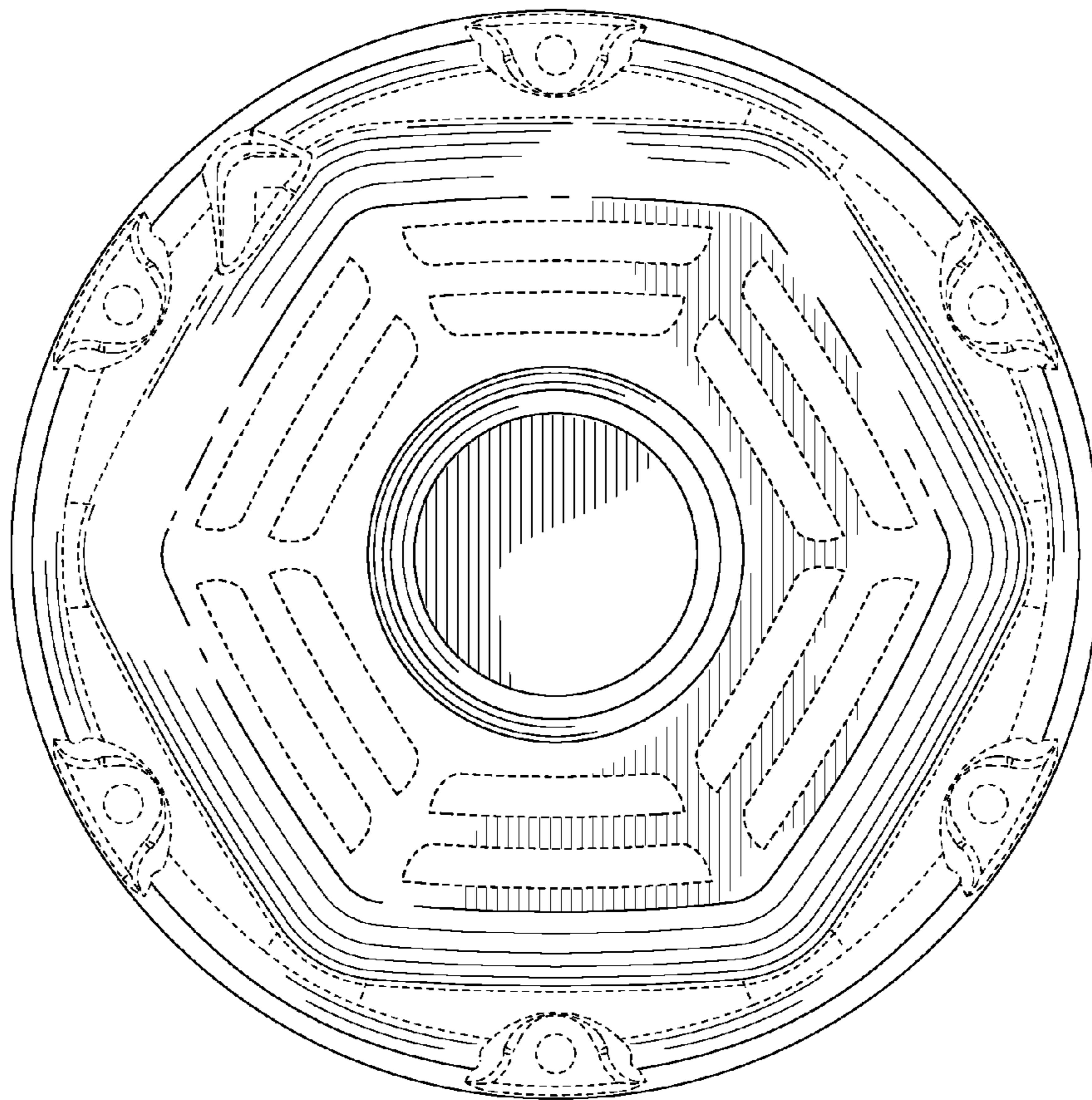

FIG. 2
AMENDED

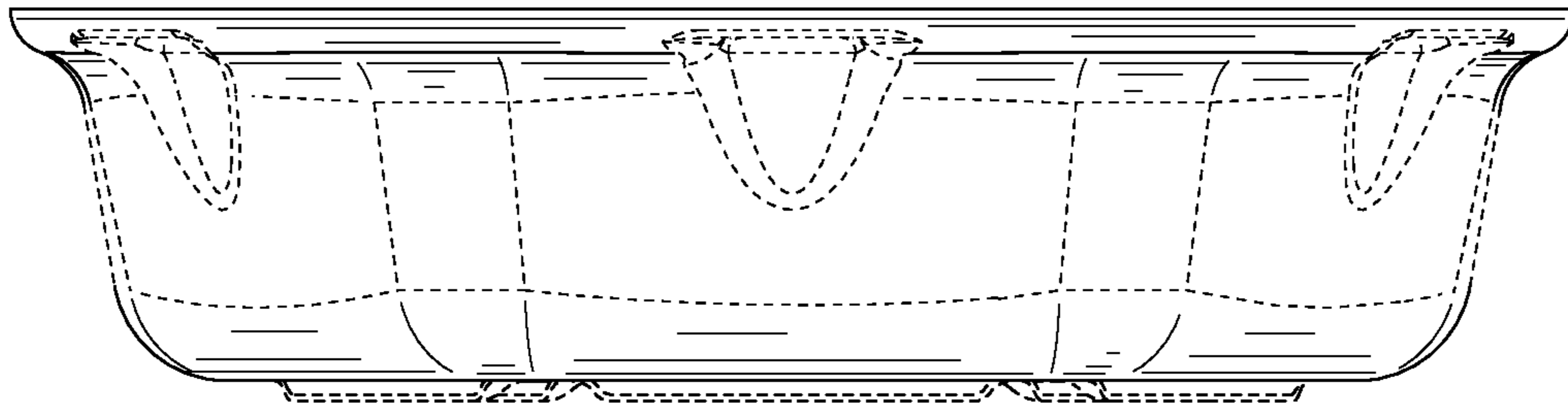

FIG. 3
AMENDED

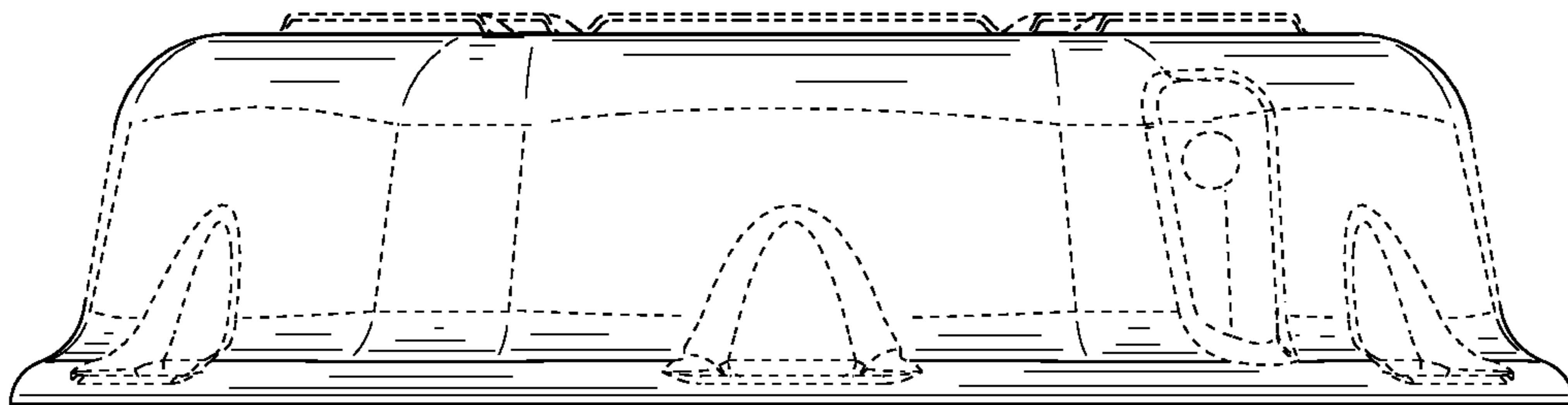

FIG. 4
AMENDED

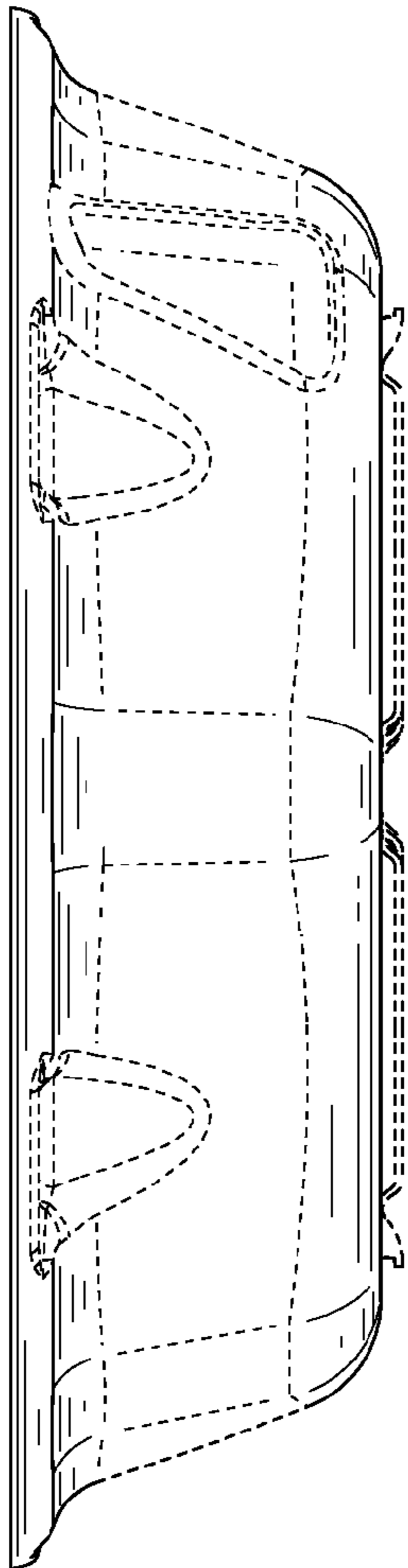
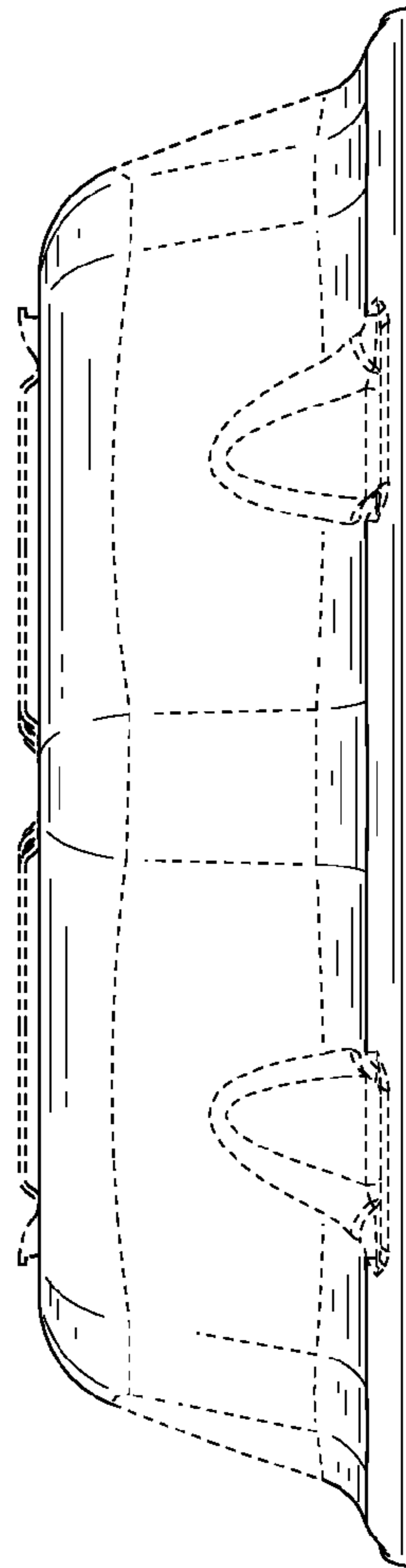

FIG. 6
AMENDED

FIG. 5
AMENDED



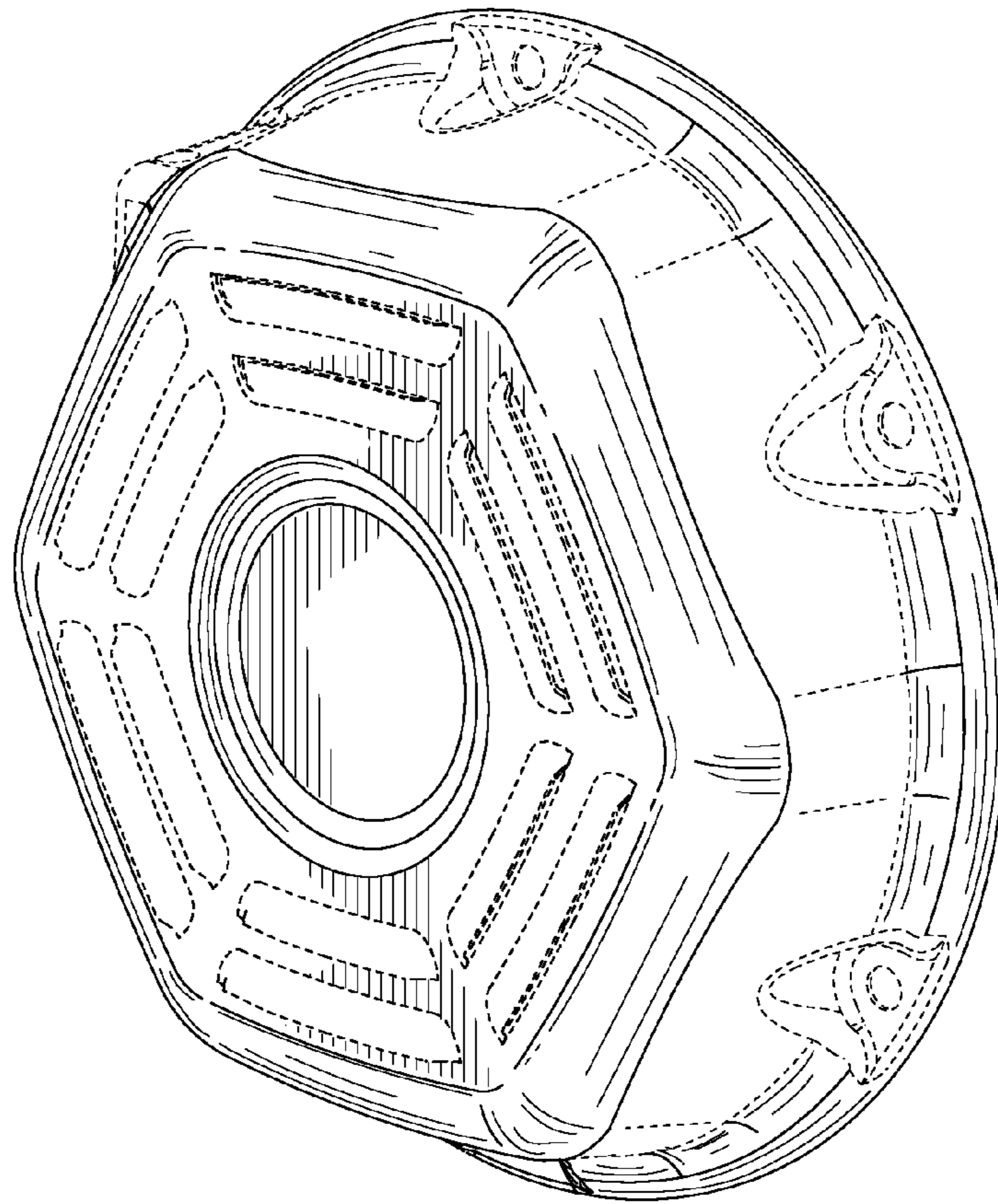

FIG. 7
NEW

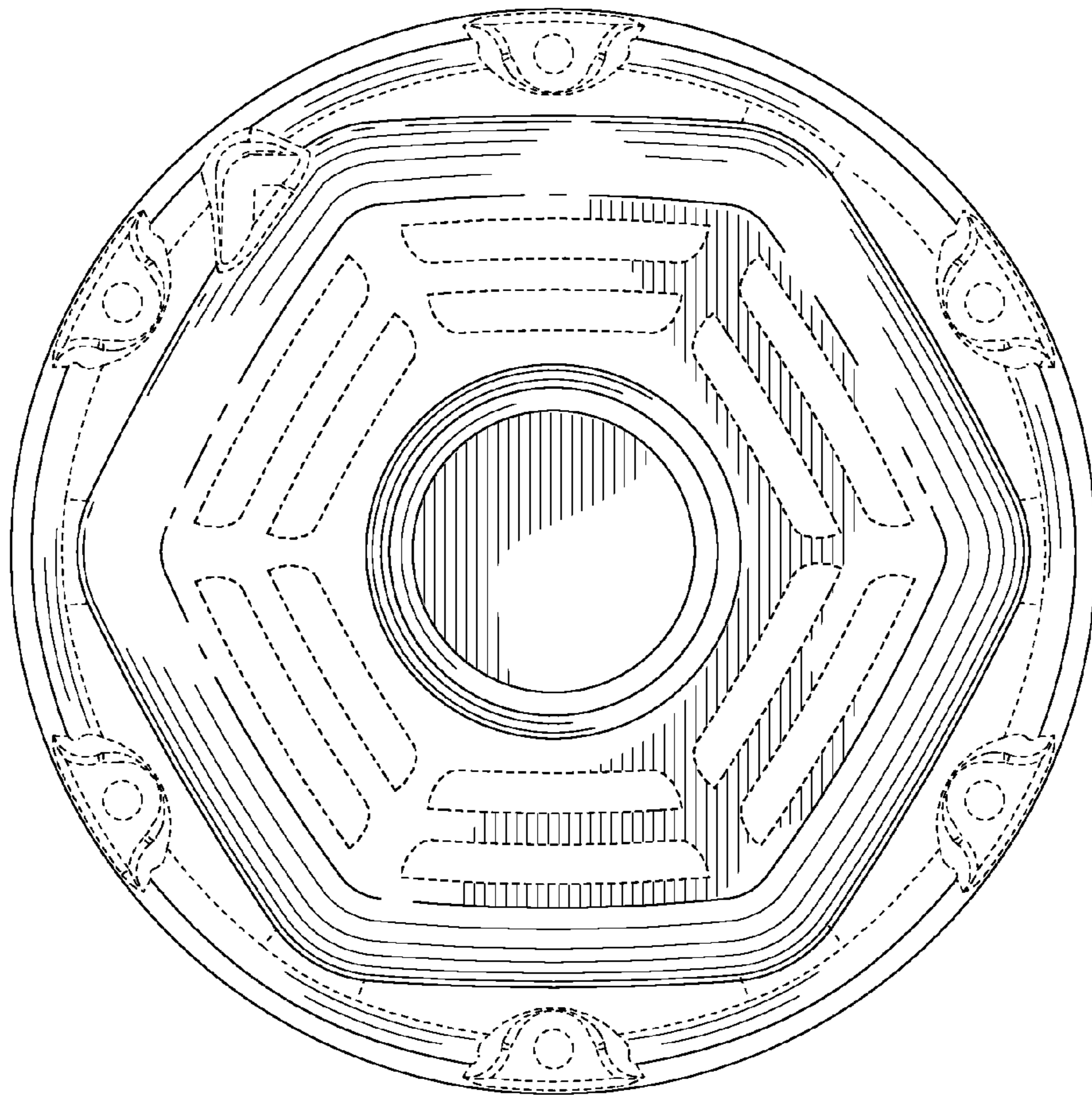

FIG. 8
NEW

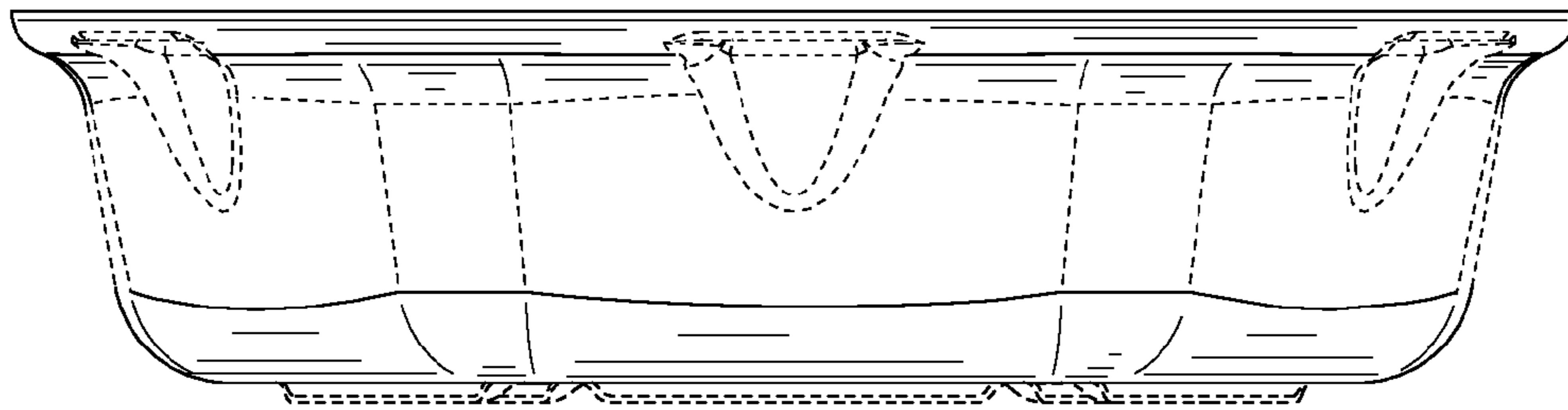

FIG. 9
NEW

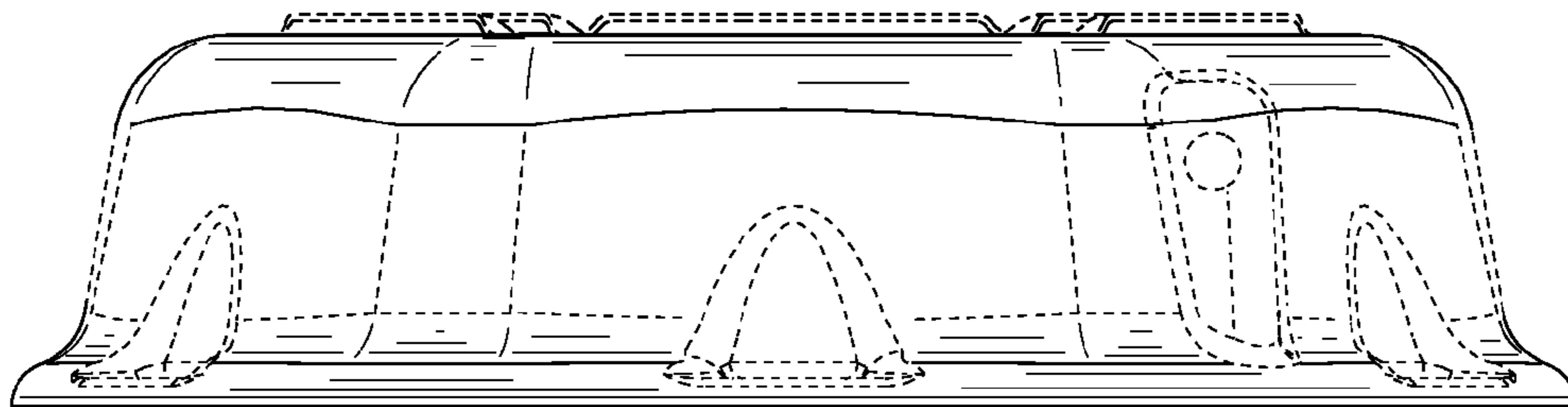

FIG. 10
NEW

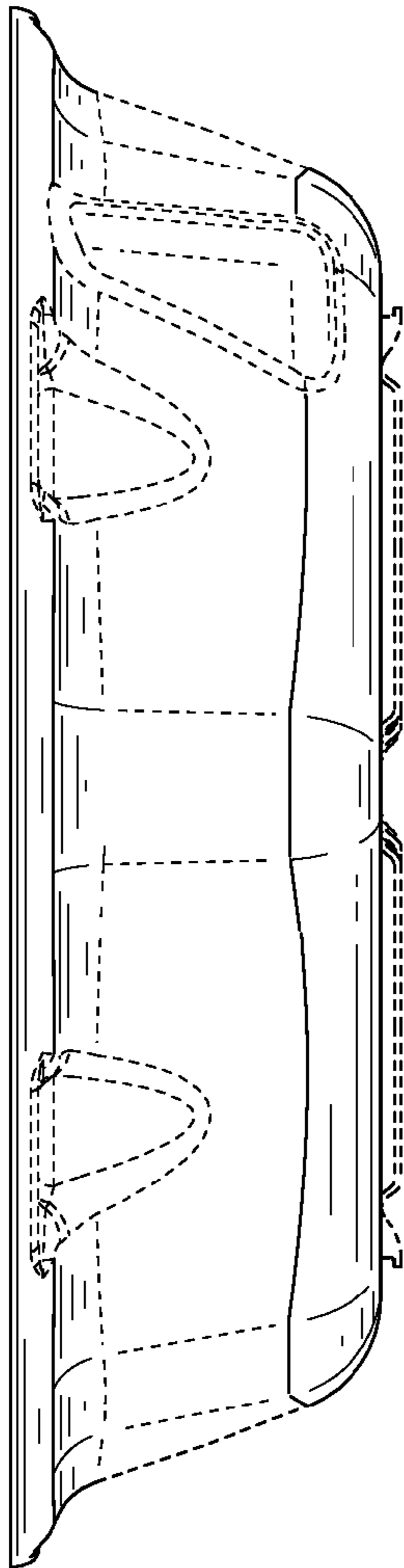
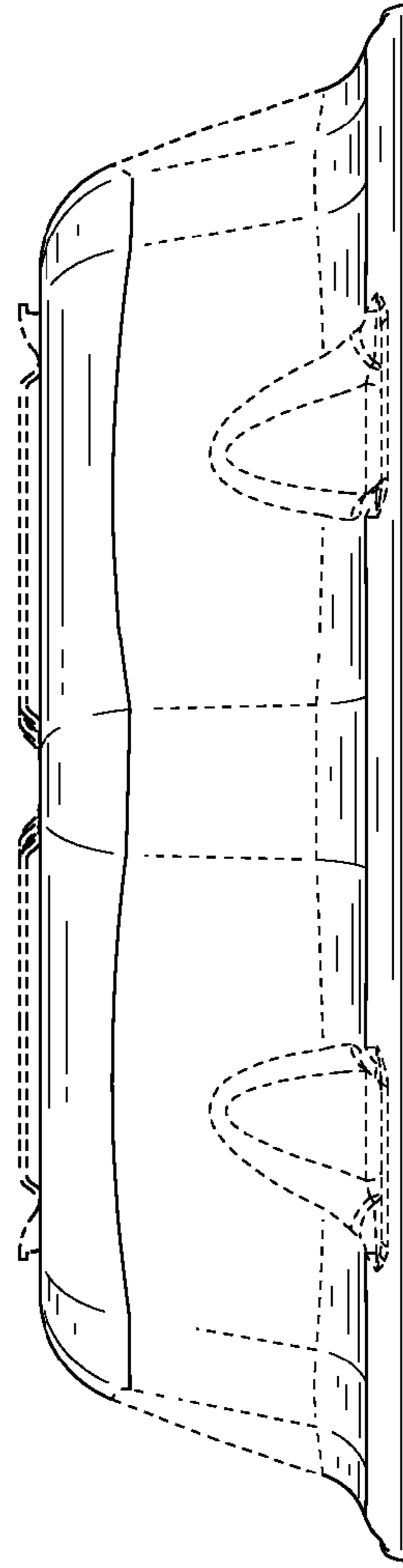

FIG. 12
NEW

FIG. 11
NEW



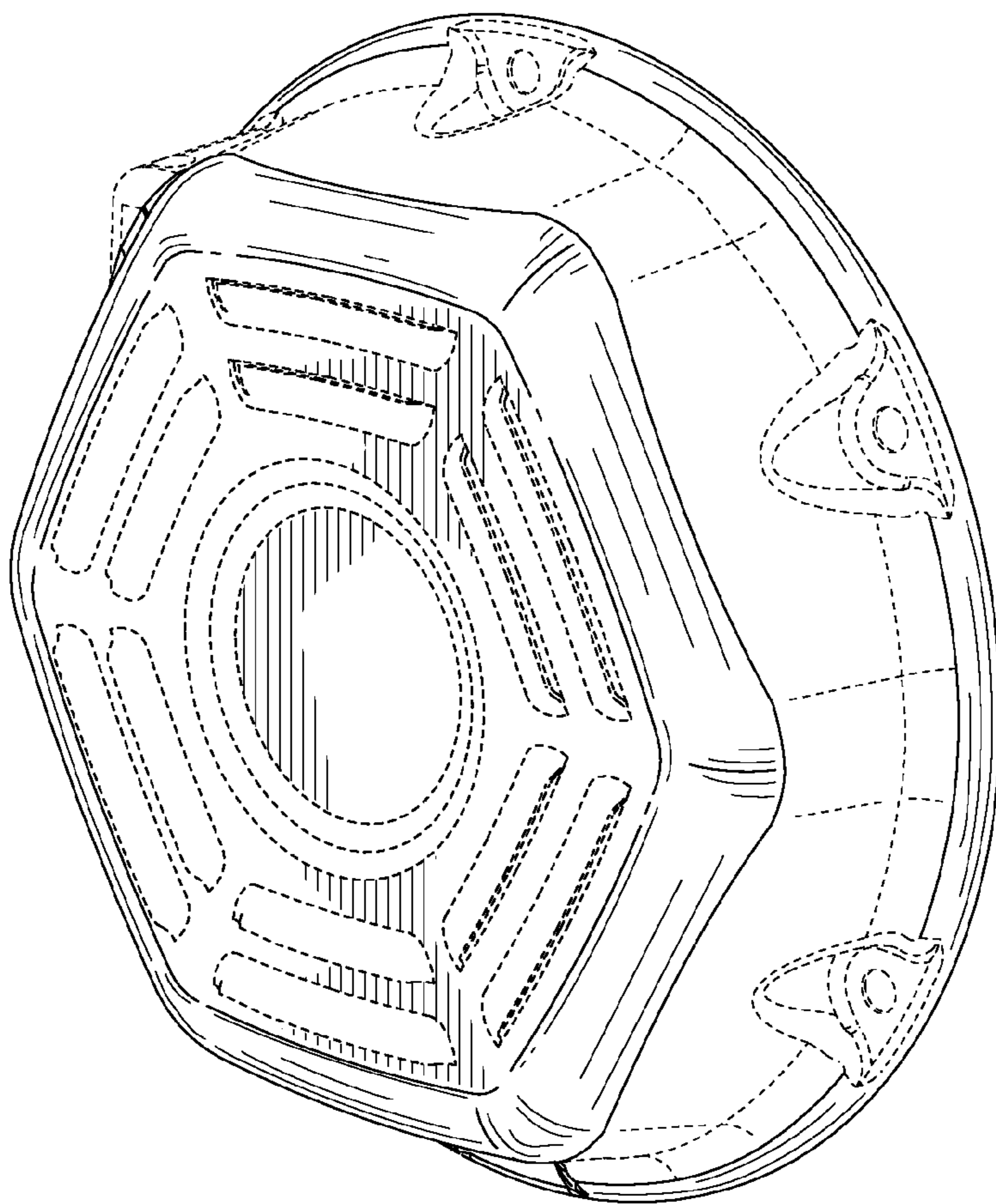

FIG. 13
NEW

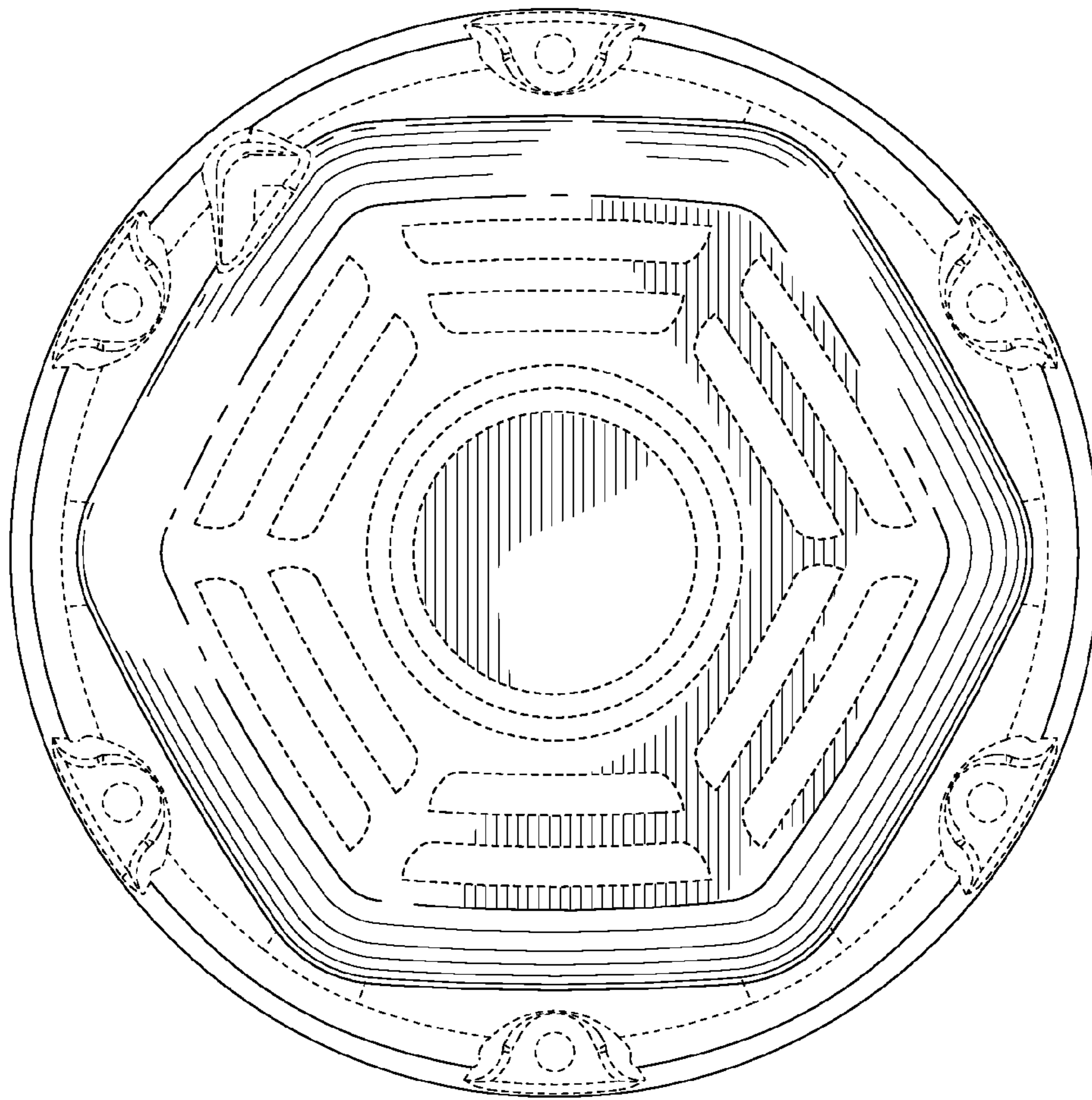

FIG. 14
NEW

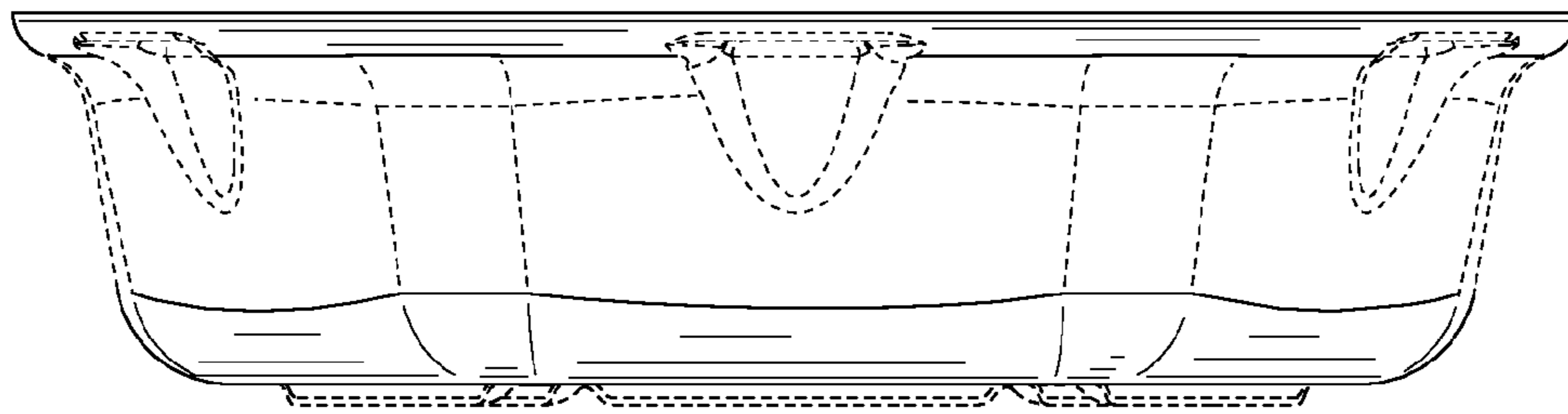

FIG. 15
NEW

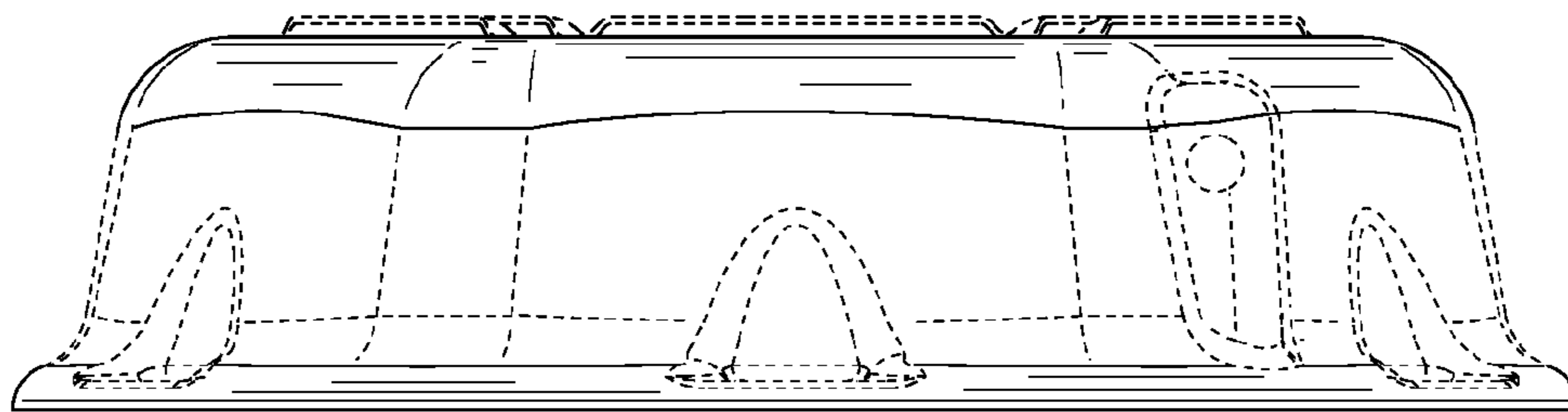

FIG. 16
NEW

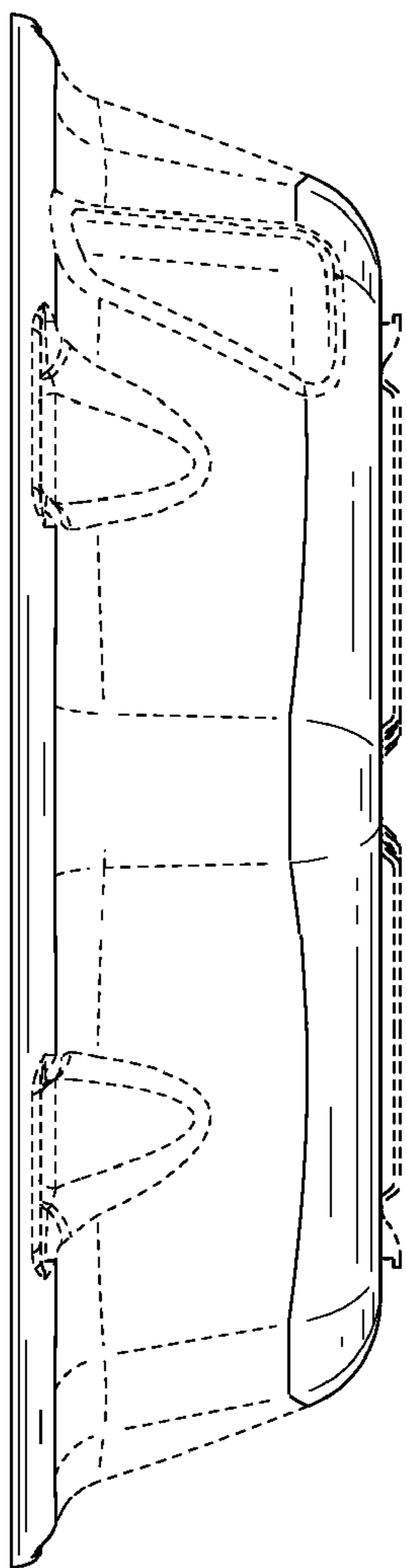

FIG. 18
NEW

FIG. 17
NEW

