



US00RE43859E

(19) **United States**
(12) **Reissued Patent**
Karim et al.

(10) **Patent Number:** **US RE43,859 E**
(45) **Date of Reissued Patent:** **Dec. 11, 2012**

(54) **METHOD FOR PRODUCING VINYL ACETATE MONOMER FROM ETHANE OR ETHYLENE OXIDATION**

(75) Inventors: **Khalid Karim**, Riyadh (SA); **Alaa E. M. Adris**, Cairo (EG)

(73) Assignee: **Saudi Basic Industries Corporation**, Riyadh (SA)

4,370,492 A	1/1983	Wunder et al.
4,902,823 A	2/1990	Wunder et al.
5,185,308 A	2/1993	Bartley et al.
6,013,597 A	1/2000	Karim et al.
6,030,920 A	2/2000	Karim et al.
6,060,421 A	5/2000	Karim et al.
6,194,610 B1	2/2001	Borchert et al.
6,399,816 B1	6/2002	Borchert et al.
6,670,504 B1	12/2003	Borchert et al.
7,491,843 B2 *	2/2009	Jobson et al. 560/241

(21) Appl. No.: **11/363,148**

(22) Filed: **Feb. 8, 2006**

FOREIGN PATENT DOCUMENTS

DE	19630832 A1	2/1998	
WO	98/05620 A1	2/1998 53/8
WO	WO98/05620	2/1998	

Related U.S. Patent Documents

Reissue of:

(64) Patent No.: **6,143,921**
Issued: **Nov. 7, 2000**
Appl. No.: **09/312,683**
Filed: **May 14, 1999**

(51) **Int. Cl.**
C07C 67/05 (2006.01)
C07C 67/02 (2006.01)
C07C 51/16 (2006.01)
C07C 53/08 (2006.01)

(52) **U.S. Cl.** **560/245; 560/261; 562/549; 562/607**

(58) **Field of Classification Search** None
See application file for complete search history.

(56) **References Cited**

U.S. PATENT DOCUMENTS

3,190,912 A	6/1965	Robinson
3,637,819 A	1/1972	Sennewald et al.
3,650,896 A	3/1972	Goeddel
3,792,087 A	2/1974	McClain et al.
3,970,697 A	7/1976	Scheben et al.
4,188,490 A	2/1980	Hinnekamp et al.

FOREIGN PATENT DOCUMENTS

DE	19630832 A1	2/1998	
WO	98/05620 A1	2/1998 53/8
WO	WO98/05620	2/1998	

(Continued)

OTHER PUBLICATIONS

White et al, Basic Energy Sciences Advisory Committee Subpanel Workshop Report, Opportunities for Catalysis in the 21st Century, 2002, pp. 1-47.*

(Continued)

Primary Examiner — Paul A Zucker
(74) *Attorney, Agent, or Firm* — Cantor Colburn LLP

(57) **ABSTRACT**

Methods for the catalytic production of vinyl acetate monomer from ethane, ethylene or an ethane/ethylene mixture using a first catalyst containing MoVNbPd, MoVLAPdNbX (where X is Al, Ga, Ge or Si) or MoVNBX (where X is P, B, Hf, Te, As or mixtures thereof) in the first step of oxidation and using a conventional VAM catalyst for the second step. The method produces high yields to acetic acid and vinyl acetate without the coproduction of carbon monoxide. Further-more, the ethylene and acetic acid produced in the first step may be utilized in the second step for VAM production

32 Claims, 2 Drawing Sheets

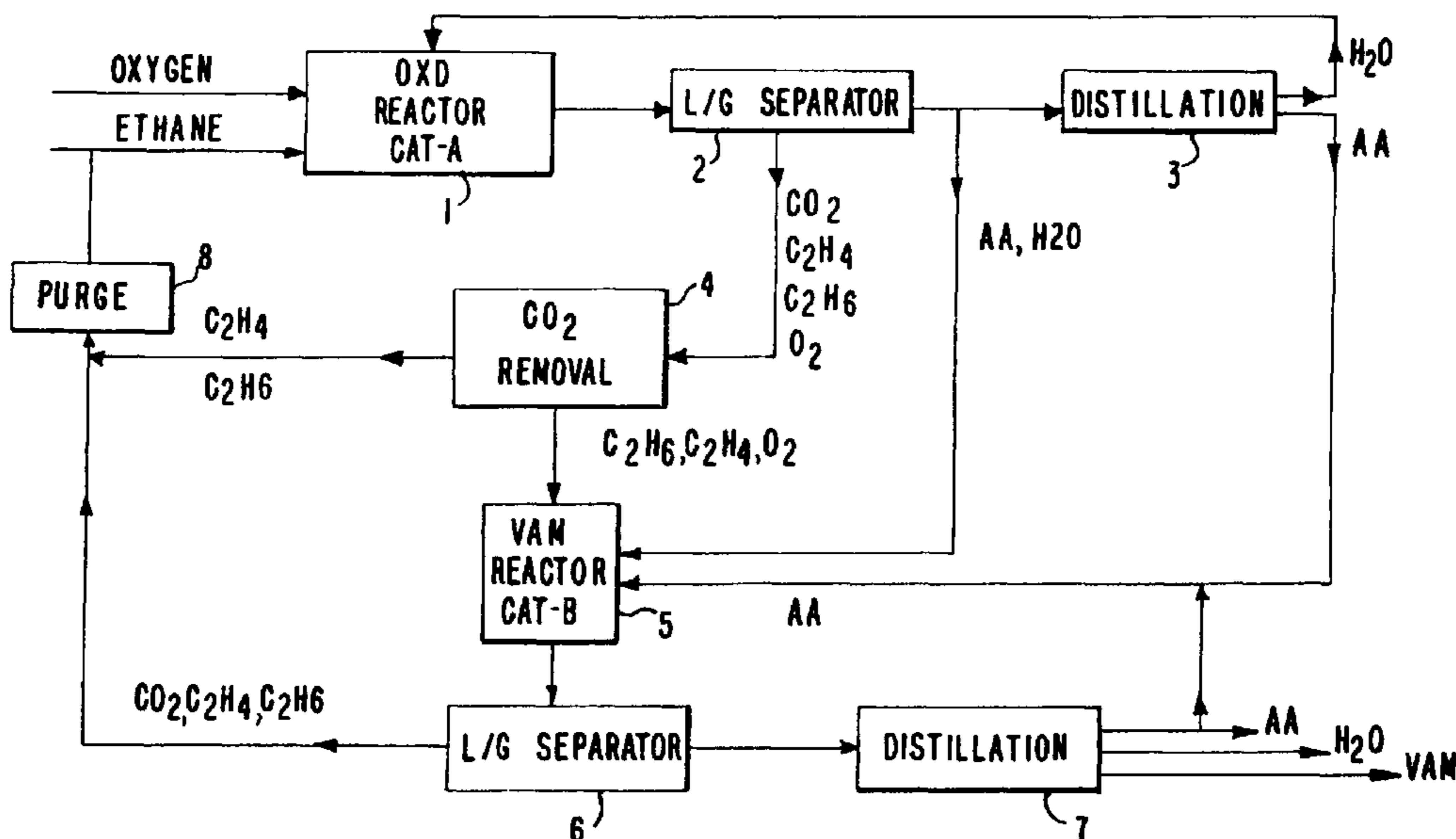

FOREIGN PATENT DOCUMENTS

WO	9847851 A1	10/1998
WO	9913980 A1	3/1999
WO	20592	4/1999
WO	WO99/20592	4/1999
WO	0000284 A1	1/2000
WO	0069802 A1	11/2000

OTHER PUBLICATIONS

Cordonna et al.; "Gas Turbine Emission Control: Platinum and Platinum-Palladium Catalysts for Carbon Monoxide and Hydrocarbon Oxidation"; Platinum Metals Rev.; vol. 33, Issue 2; 1989; pp. 46-54; Opposition Against European Patent No. 1180092 (B1); Submitted to the European Patent Office Jul. 8, 2006.

Decision to Revoke; Opposition Against European Patent No. 1180092 (B1); Mailed Mar. 29, 2010; 7 Pages.

Grounds for Appeal; Submitted by Forrester & Boehmert; Opposition Against European Patent No. 1180092 (B1); Submitted to the European Patent Office Jul. 2, 2010; 14 Pages.

Notice of New Opposition; Submitted by BP International Limited; Opposition Against European Patent No. 1180092 (B1); Submitted to the European Patent Office Jul. 7, 2006; 7 Pages.

Notice of New Opposition; Submitted by Celanese; Opposition Against European Patent No. 1180092 (B1); Submitted to the European Patent Office Jul. 8, 2006; 13 Pages.

Notice of Appeal; Submitted by Forrester & Boehmert; Opposition Against European Patent No. 1180092 (B1); Submitted to the European Patent Office Mar. 31, 2010; 2 Pages.

Minutes from Oral Proceedings; Opposition Against European Patent No. 1180092 (B1); Mailed Mar. 29, 2010; 7 Pages.

Research Disclosure 2244; Jun. 1992; Opposition Against European Patent No. 1180092 (B1); Submitted to the European Patent Office Jul. 8, 2006; 6 Pages.

Response to Notice of Opposition; Submitted by Saudi Basic Industries Corporation (SABIC); Opposition Against European Patent No. 1180092 (B1); Submitted to the European Patent Office Feb. 27, 2007; 28 Pages.

Response to Office Action dated Jul. 15, 2003; Submitted by Forrester & Boehmert; Opposition Against European Patent No. 1180092 (B1); Submitted to the European Patent Office Nov. 4, 2003; 3 Pages.

Summons to Attend Oral Proceedings; Opposition Against European Patent No. 1180092 (B1); Mailed Aug. 7, 2009; 11 Pages.

Vinyl Acetate; Chem Systems; Oct. 1992; Opposition Against European Patent No. 1180092 (B1); Submitted to the European Patent Office Jul. 8, 2006; 7 Pages.

Vinyl Esters; Ullmann's Encyclopedia of Industrial Chemistry; 5th Edition, vol. A 27; Opposition Against European Patent No. 1180092 (B1); Submitted to the European Patent Office Jul. 8, 2006; 10 Pages.

Written Submissions from BP International Limited in Response to Grounds of Appeal; Opposition Against European Patent No. 1180092 (B1); Submitted to the European Patent Office on Nov. 19, 2010; 10 Pages.

Written Submissions from von Kreisler Selting Werner in Response to Grounds of Appeal; Opposition Against European Patent No. 1180092 (B1); Submitted to the European Patent Office on Nov. 22, 2010; 9 Pages.

Written Submissions from Forrester & Boehmert in Response to Grounds of Appeal; Opposition Against European Patent No. 1180092 (B1); Submitted to the European Patent Office on Mar. 16, 2011; 23 Pages.

Written Submissions; Submitted by von Kreisler Selting Werner; Opposition Against European Patent No. 1180092 (B1); Submitted to the European Patent Office Dec. 18, 2009; 4 Pages.

Written Submissions; Submitted by Saudi Basic Industries Corporation (SABIC); Opposition Against European Patent No. 1180092 (B1); Submitted to the European Patent Office Dec. 18, 2009; 14 Pages.

* cited by examiner

FIG. 1

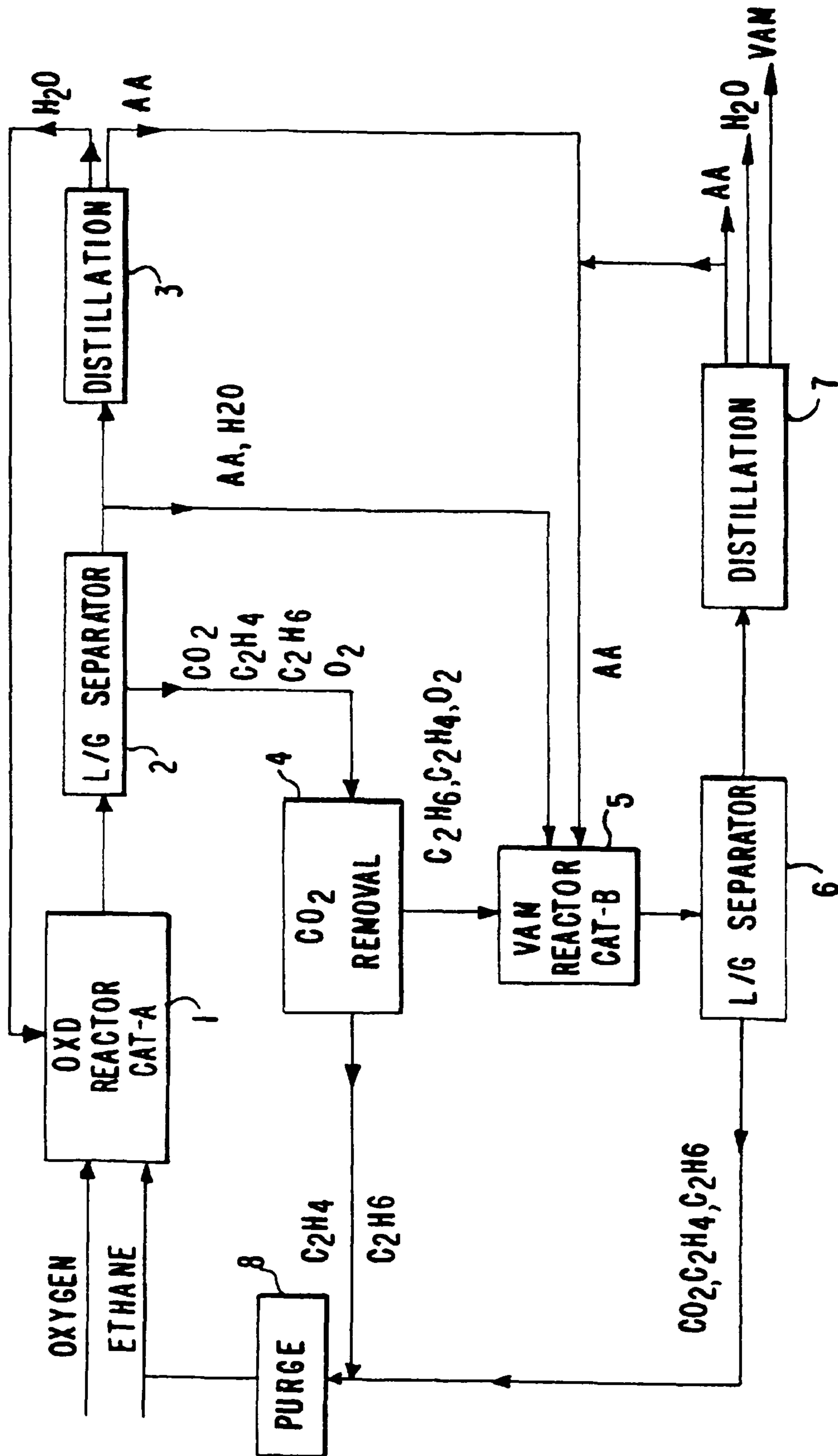
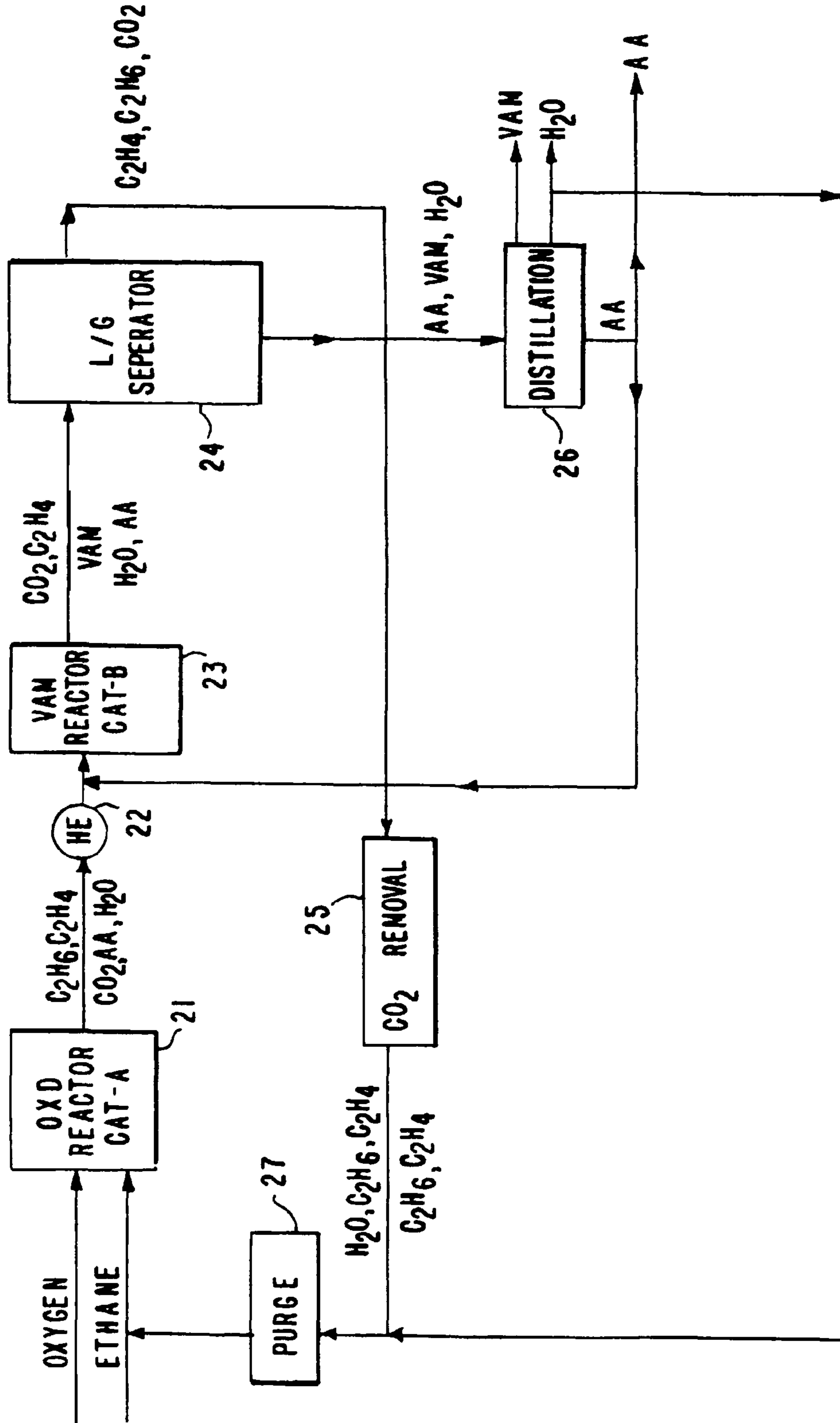

FIG. 2



1

**METHOD FOR PRODUCING VINYL
ACETATE MONOMER FROM ETHANE OR
ETHYLENE OXIDATION**

Matter enclosed in heavy brackets [] appears in the original patent but forms no part of this reissue specification; matter printed in italics indicates the additions made by reissue.

BACKGROUND OF THE INVENTION

1. Field of the Invention

The invention relates to improved integrated methods of making vinyl acetate monomers from ethane or ethylene using metal oxide catalysts.

2. Description of the Related Art

Several publications are referenced in this application. These references describe the state of the art to which this invention pertains and are hereby incorporated by reference.

The utilization of lower alkanes (C₁-C₄) as feed stock to produce value added petrochemicals is an industrially desired process. Lower alkanes are low cost and environmentally acceptable because of their low chemical reactivity. There are only a few commercially available chemical catalytic processes, which utilize lower alkanes as a feed, such as butane to maleic anhydride.

Vinyl acetate monomer (VAM) is a well-known industrial chemical. The production of VAM from ethylene, oxygen and acetic acid using conventional VAM catalysts is known in the art. VAM is typically used as a raw material for vinyl resins such as polyvinyl acetate. VAM was previously primarily manufactured from the vapor phase reaction of ethylene, acetic acid and oxygen with a zinc acetate catalyst.

More recently, VAM has been produced from the vapor-phase reaction of ethylene, acetic acid and oxygen, with a palladium catalyst. For example, VAM may be made from ethylene wherein the first step involves reacting the ethylene to form acetic acid, followed by a second step of reacting a mixture of the acetic acid and ethylene to form vinyl acetate.

Numerous methods are known for the catalytic oxidation of ethylene to acetic acid. See, for example, U.S. Pat. Nos. 3,792,087 and 3,970,697. Similarly, numerous methods are known for the catalytic production of vinyl acetate by reacting ethylene with acetic acid and oxygen in the gaseous phase. See, U.S. Pat. Nos. 3,190,912; 3,637,819; 3,650,896; 4,370,492; 5,185,308; and 4,902,823.

PCT Patent Publication WO 98/05620 describes the production of acetic acid and/or vinyl acetate from ethylene (or ethane) using a first catalyst active for the oxidation of ethylene to acetic acid and/or active for the oxidation of ethane to acetic acid, ethylene and carbon monoxide, and a second catalyst active for the production of vinyl acetate. The patent also describes an additional necessary step for conversion of carbon monoxide to carbon dioxide. This is because carbon monoxide is poisonous to the VAM catalyst.

U.S. Pat. No. 4,188,490 relates to a catalytic oxidation process for the production of mixtures of acetic acid and vinyl acetate comprising the step of contacting a feed mixture containing ethylene, oxygen and water (as steam) with a catalyst composition to provide a mixture of acetic acid and vinyl acetate. The catalyst system comprises a palladium metal on a zinc oxide support treated in the presence of a sulfur modifier. The method requires the subsequent step of fractional distillation to separate the acetic acid from the vinyl acetate. Alternatively, the acetic acid contained in the product mixture is converted in situ to an alkali metal salt such as sodium

2

acetate. The method also requires the step of treating the catalyst with the sulfur modifier by, for example, flowing moist air containing SO₂ over the catalyst at 200° C. for about one hour.

Several methods for producing vinyl acetate from ethylene result in the production of carbon monoxide. The production of carbon monoxide is disadvantageous because it is poisonous to the second stage catalyst. Moreover, carbon monoxide is also a less desirable by-product due to environmental law constraints. In order to avoid this problem, it is necessary to introduce another catalytic reactor for the total oxidation of CO to CO₂. This can add significant costs to the catalytic process.

Accordingly, it would be desirable to provide an improved method for the selective production of vinyl acetate monomer from ethane without the production of carbon monoxide.

OBJECTS OF THE INVENTION

It is an object of the invention to overcome the above-identified deficiencies.

It is another object of the invention to provide an improved catalytic method for the production of vinyl acetate.

It is a further object of the invention to provide an improved catalytic method for the oxidation of ethylene to produce vinyl acetate.

It is a further object of the invention to provide an improved catalytic method for the oxidation of ethane to produce vinyl acetate.

It is a still further object of the invention to provide an improved catalytic method for the oxidation of ethane, ethylene or a mixture of ethane and ethylene to produce vinyl acetate without the production of carbon monoxide as a by-product.

It is yet another object of the invention to provide an improved catalytic method for the single stage oxidation of ethane or ethylene or mixtures thereof to vinyl acetate.

The foregoing and other objects and advantages of the invention will be set forth in or be apparent from the following description.

SUMMARY OF THE INVENTION

According to the present invention, vinyl acetate is produced catalytically from ethane feed stocks. Another aspect of the invention relates to the production of vinyl acetate from ethylene. The catalysts suitable for use in the methods of the invention are active and selective to the desired end product, vinyl acetate. The catalytic process for the production of VAM from ethane involves two steps. In the first step, a catalyst (the "first catalyst") is used to provide the function of activation of ethane to ethylene and acetic acid. In the second step, ethylene and acetic acid are further oxidized to VAM in the presence of a conventional VAM catalyst (the "second catalyst"). Another preferred embodiment relates to a method of forming a stoichiometric mixture of ethylene and acetic acid using the first catalyst, which mixture can be directly fed into a vinyl acetate reactor containing the VAM catalyst without adjustments. Yet another preferred embodiment relates to a catalytic method wherein ethylene or ethane is converted to vinyl acetate in a single stage reactor.

Advantageously, the preferred catalytic methods of the invention do not produce carbon monoxide. This is advantageous because carbon monoxide is not environmentally friendly and can have a significant impact on down stream separation costs, as well as on the poisoning of the VAM catalyst.

Other objects as well as aspects, features and advantages of the present invention will become apparent from a study of the present specification, including the claims, figures and specific examples.

DESCRIPTION OF THE FIGURES

FIG. 1 is a schematical representation of a ethane to VAM reaction scheme according to one embodiment of the invention.

FIG. 2 is a schematical representation of a ethane to VAM reaction scheme according to another embodiment of the invention.

DESCRIPTION OF THE PREFERRED EMBODIMENTS

The invention relates to novel methods of producing vinyl acetate. In the first step, the first catalyst is used which provides the dual functions of (a) activation of ethane (or ethane/ethylene) to acetic acid and ethylene and (b) ethylene to acetic acid. In the second step, vinyl acetate is formed through further oxidation of ethylene with acetic acid in the presence of a second catalyst, the VAM catalyst. According to one preferred embodiment, the catalysts of the invention can also be used to provide an optimal feed to a vinyl acetate reactor. That is, catalytically oxidizing ethane (or ethylene/ethane) to form a mixture containing the optimal stoichiometric mixture of ethylene and acetic acid for use as a feed to a vinyl acetate reactor containing the conventional VAM catalyst, such as a Pd/Al catalyst.

The catalyst system suitable for the first step of the present invention (the first catalyst) can be formed from compositions including a catalyst (a) of the formula $Mo_aV_bNb_cPd_d$, wherein:

- a is 1 to 5;
- b is 0 to 0.5;
- c is 0.01 to 0.5; and
- d is 0 to 0.2.

The numerical values of a, b, c and d represent the relative gram-atom ratios of the elements Mo, V, Nb and Pd, respectively, in the catalyst. The elements are preferably present in combination with oxygen in the form of various oxides.

Another catalyst system, catalyst (b), has a composition comprising the elements Mo, V, Pd, Nb, La, and X where X is Al, Ga, Si, or Ge) in the form of oxides in the ratio $Mo_aV_bLa_cPd_dNb_eX_f$ wherein:

- a is 1;
- b is 0.01 to 0.9;
- c is >0 to 0.2;
- d is >0 to 0.2.
- e is >0 to 0.2; and
- f is >0 to 0.3.

The numerical values of a, b, c, d, e and f represent the relative gram-atom ratios of the elements Mo, V, Pd, La, Nb and X, respectively, in the catalyst. The elements are preferably present in combination with oxygen in the form of various oxides.

Another catalyst system, catalyst (c), suitable for the invention is formed from a calcined composition of $Mo_aV_bNb_cX_d$, wherein:

- X is at least one promoter element selected from the group consisting of: P, B, Hf, Te, and As;
- a is about 1 to 5;
- b is 1;
- c is about 0.01 to 0.5; and
- d is about 0 to 0.1.

The numerical values of a, b, c and d represent the relative gram-atom ratios of the elements Mo, V, Nb and X, respectively, in the catalyst. The elements are preferably present in combination with oxygen in the form of various oxides.

The first catalyst (catalysts (a) or (b) or (c) or mixtures thereof) and methods of making the first catalyst are set forth in copending U.S. application Ser. No. 08/932,075, filed Sep. 17, 1997, entitled "Catalysts for the Oxidation of Ethane to Acetic Acid, Processes of Making the Same and Processes of Using the Same"; U.S. patent application Ser. No. 08/997,913, filed Dec. 24, 1997, entitled "Catalyst for Producing Acetic Acid from Ethane Oxidation, Processes of Making the Same and Methods of Using the Same" and U.S. Ser. No. 09/219,702, filed Dec. 23, 1998, entitled "Catalysts for the Oxidation of Ethane to Acetic Acid, Methods of Making and Using the Same", each of which is herein incorporated by reference.

One broad aspect of the invention relates to the production of vinyl acetate from ethane, ethylene or mixtures of ethane and ethylene. The method utilizes a first catalyst ((a) or (b) or (c) or mixtures thereof) providing the functions of activation of ethane to acetic acid and ethylene and further oxidation of ethylene with acetic acid to vinyl acetate using a conventional VAM catalyst such as a Pd/Al catalyst. Overall, the recycled yield for vinyl acetate can be greater than 95%.

Advantageously, the methods of the invention produce vinyl acetate with zero (or nondetectable) or insignificant production of carbon monoxide. Preferably, less than 0.1 wt % carbon monoxide is produced as an end product using the invention, more preferably less than 0.01% and most preferred no detectable carbon monoxide is produced. Accordingly, one preferred aspect of the invention relates to a method which employs a catalyst designed in such way that it does not produce any CO, which saves the treatment step of converting CO to CO₂.

One embodiment of the invention comprises reacting ethane with oxygen and water (e.g. steam) in the presence of a first catalyst ((a) or (b) or (c) or mixtures thereof) to form a mixture containing ethylene and acetic acid which is then reacted to form vinyl acetate.

The raw material used as the source for the ethane or ethylene/ethane can be a gas stream, which preferably contains at least five volume percent of ethane/ethylene. The gas can also contain minor amounts of the C₃-C₄ alkanes and alkenes, preferably less than five volume percent of each. The gas stream can also contain major amounts, preferably more than five volume percent, of nitrogen, carbon dioxide, and water in the form of steam.

The reaction mixture useful in carrying out the process is generally from 5 to 50 moles % of ethane, 5 to 50 moles % of molecular oxygen either as pure oxygen or in the form of air, and optionally 2 to 50 moles % of water in the form of steam. The amount of oxygen present may be a stoichiometric amount, or lower, of the hydrocarbons in the feed. Other gases may be used as reaction diluents or heat moderators such as helium, nitrogen, and carbon dioxide.

The gaseous components of the reaction mixture are preferably uniformly admixed prior to being introduced into the reaction zone. The components may be preheated, individually or after being mixed, prior to being introduced into the reaction zone.

The first reaction zone, containing the first catalyst ((a) or (b) or (c) or mixtures thereof), generally has a pressure of from 15 to 500 psi, preferably from 150 to 350 psi; a temperature of from about 100° C. to about 450° C., preferably from 200° C. to 350° C., more preferably from 250° C. to 300° C.; a contact time between the reaction mixture and the

5

catalyst of from about 2 seconds to about 100 seconds, preferably from 5 seconds to 30 seconds; and a space hourly velocity of from about 50 to about 50,000 h⁻¹, preferably from 100 to 10,000 h⁻¹ and most preferably from 200 to 3,000 h⁻¹.

According to one preferred embodiment, the process occurs in two stages. In the first stage, a mixture comprising ethane or ethylene, oxygen or a compound capable of providing oxygen and water (e.g., steam) is reacted to form a mixture containing ethylene, acetic acid, oxygen and water (e.g., steam). The product mixture of the first stage is then fed into the second stage and reacted to produce vinyl acetate.

The feed from the first stage may be adjusted prior to being introduced into the second stage. For example, the oxygen, ethylene and acetic acid concentration may be adjusted to optimize the catalytic reaction. Preferably, the first stage of the process produces a stoichiometric composition of acetic acid and ethylene as a feed for the second stage. According to one particularly preferred embodiment, adjustments of the feed for the second reactor are not required as the mixture produced in the first stage can be directly fed into the second stage. Thus, a dual-function catalyst can be used in the first stage to provide the feed stock for the second stage, which may contain a conventional Pd/Al VAM catalyst or any catalyst suitable for converting the feed stock of acetic acid and ethylene to VAM.

Therefore, using the present invention, VAM can also be directly produced from only ethane, oxygen and water without additional components since the outlet of the first reactor may be optimized to contain a stoichiometric mixture of acetic acid, ethylene and oxygen which is the feed mixture for the second reactor. Preferably, the temperature and pressure of the feed from the first stage are also not adjusted prior to the second stage.

According to one embodiment, the output from either the first or second stage is recycled into the same or an earlier stage. For example, the output from stage 1 may be recycled into stage 1 or the output from stage 2 may be recycled into stage 1 and/or stage 2.

According to another embodiment, the reaction zone comprises multiple stages of bilayered catalyst consisting of layers of a first catalyst ((a) or (b) or (c) or mixtures thereof) according to the invention and a second conventional vinyl acetate catalyst. In this manner, the first catalyst converts ethane to a mixture of acetic acid and ethylene, preferably to an optimal mixture, and the second catalyst converts the ethylene/acetic acid to vinyl acetate in a single reaction zone.

Accordingly, one preferred embodiment relates to a process carried out in a single stage with all the reactants being supplied as a single feed with unreacted initial reactants being recycled. However, multiple stage addition of oxygen to the reactor with an intermediate hydrocarbon feed can also be used. This may improve productivity to vinyl acetate and avoid potentially hazardous conditions.

Two possible integrated schemes using the first catalyst and the second VAM catalyst for direct production of VAM from ethane or ethane/ethylene mixtures without producing carbon monoxide are shown in FIGS. 1 and 2.

FIG. 1 is schematical representation of one reaction scheme A according to one embodiment of the invention. The partial oxidation reactor 1 containing the first catalyst (CAT-A) converts fresh and recycled ethane or ethane/ethylene with oxygen into ethylene, acetic acid and carbon dioxide. An optimum amount of water from distillation reactor 3 is also introduced to partial oxidation reactor 1 in order to increase

6

the acetic acid selectivity. The effluent from partial oxidation reactor 1 enters a gas/liquid separation unit 2. The gas stream from gas/liquid separation unit 2 is recycled to partial oxidation reactor 1 or goes to carbon dioxide absorption unit 4, where CO₂ is removed. The liquid stream from gas/liquid separation unit 2 goes to distillation unit 3, where acetic acid is separated from water or the liquid stream from gas/liquid separation unit 2 can directly go to VAM reactor 5 containing a conventional VAM catalyst (CAT-B). The treated gases consisting of ethane, ethylene and oxygen and the liquid stream consisting of acetic acid or acetic acid and water are fed to VAM reactor 5 to produce VAM, CO₂ and unreacted ethane, ethylene and acetic acid. The effluent of VAM reactor 5 is then fed to gas liquid separation unit 6 where gases including ethane, ethylene and CO₂ are separated, partially purged to control the build up of non reacting species in purge unit 8 and recycled back to partial oxidation reactor 1. The liquids are sent to distillation unit 7 for recovery of VAM. Acetic acid or unreacted acetic acid is recycled back to VAM reactor 5.

FIG. 2 is a schematical representation of reaction scheme B according to another embodiment of the invention. The partial oxidation reactor 21 containing the first catalyst (CAT-A) converts fresh and recycled ethane or ethane/ethylene with oxygen into ethylene, acetic acid and carbon dioxide. The effluent of reactor 21 is fed to VAM reactor 23 containing the VAM catalyst (CAT-B) via optional heat exchanger 22, which allows adjustment of the temperature of the feed to VAM reactor 23. optionally, the two catalysts CAT-A and CAT-B can be in one reactor in the form of a physical mixture or in alternating layer form. Additional amounts of gases to VAM reactor 23, such as ethylene, acetic acid, and oxygen may be added depending upon the process conditions. The effluent from VAM reactor 23 is fed to gas/liquid separation unit 24, where gases including CO₂, C₂H₄, and C₂H₆ are separated from liquid VAM, acetic acid and water. The gas streams from gas/liquid separation unit 24 are recycled via carbon dioxide removal unit 25 to reactor 21. Optionally, the gas streams can also be recycled to reactor 21 without the absorption unit 25, as the catalyst CAT-A in the reactor 21 is not affected by the presence of carbon dioxide. Further, a specific amount of carbon dioxide also enhances the performance of the catalyst CAT-A. Gases are partially purged to control the build up of non reacting species in purge unit 27. Liquid stream from separator unit 24 is fed to distillation unit 26 where acetic acid is separated from VAM and water and is optionally recycled to reactor 23 for make up or can be recovered. VAM goes to a recovery unit and H₂O is recycled to reactor unit 21 for enhancement of acetic acid and selectivity.

EXAMPLES

The following examples are illustrative of some of the products and methods of making and using the same falling within the scope of the present invention. They are, of course, not to be considered in any way limitative of the invention. Numerous changes and modifications can be made with respect to the invention.

Catalytic oxidation processes using a first catalyst ((a) or (b) or (c) or mixtures thereof) were carried out in a tubular reactor under the following conditions. All experiments were run at the temperatures set forth below ranging from 260° C. to 286° C., at a pressure of about 200 psig.

Reaction products were analyzed on-line by gas chromatography. Oxygen, nitrogen and carbon monoxide were analyzed using a 3 mm by 3 mm column of 13X molecular sieve. Carbon dioxide, ethane, ethylene and water were analyzed

7

using a 1.8 m by 3 mm column packed with material sold under the name HAYASEP™. Acetic acid was analyzed using a 0.5 m by 3 mm column packed with material sold under the name PORAPACK™ N.

In all cases, the conversion and selectivity calculations were based on the stoichiometry.

Data for the stage I reaction mentioned in the examples is experimental and the production of vinyl acetate (VAM) data in the stage II is calculated based on 92% yield to VAM from ethylene (Chem. System 91-10, October 1992, herein incorporated by reference).

Example 1

The Production of VAM from Ethylene

The first catalyst (catalyst (a)): $\text{MoV}_{0.396}\text{Nb}_{0.128}\text{Pd}_x\text{O}_y$ (where $x=1.90\text{e-}04$ and y is based on the co-ordination valence)

Process conditions for stage I reactor: $286^\circ\text{C./}200\text{ psi}$

Process conditions for stage II reactor as described in reference Chem. System 91-10, October 1992.

Results data:

Compound (g.mol.min.)	Stage I		Stage II	
	Feed	Product	Feed	Product
Ethylene	5.65E-4	2.07E-4	2.07E-4	
Oxygen	6.73E-4	1.23E-4	1.23E-4	
Nitrogen	2.53E-3	2.47E-4		
Water	2.23E-5	2.13E-4		
Acetic Acid		2.80E-4	2.80E-4	
CO ₂		1.56E-4		
VAM				1.90E-4

The nitrogen, CO₂ and water are diluents in the stage II reaction.

Example 2

The Production of VAM from Ethane

First catalyst (catalyst (a)): $\text{MoV}_{0.396}\text{Nb}_{0.128}\text{Pd}_x\text{O}_y$ (where x is $1.90\text{e-}04$ and y is based on the co-ordination valence)

Process conditions for stage I reactor: $286^\circ\text{C./}200\text{ psi}$.

Process conditions for stage II reactor as described in Chem System 91-10, October 1992.

Results data:

Compound (g.mol.min.)	Stage I		Stage II	
	Feed	Product	Feed	Product
Ethane	4.43E-04	2.40E-4		
Oxygen	5.10E-04	5.07E-05	5.07E-05	
Nitrogen	1.92E-03	1.98E-03		
Water		3.18E-04		
Ethylene		8.86E-05	8.86E-05	
Acetic Acid	9.28E-05	9.28E-05		
CO ₂		1.77E-04		
VAM				9.00E-5

The nitrogen, CO₂ and water act as diluents in stage II.

8

Example 3

The Production of VAM from Ethane

First catalyst (catalyst (a)): $\text{Mo}_{2.5}\text{V}_{1.0}\text{Nb}_{0.32}\text{Pd}_{0.03}\text{O}_y$ (where y is based on the coordination valence)

Process conditions for stage I reactor: $260^\circ\text{C./}200\text{ psi}$.

Process conditions for stage II reactor as described in Chem. System 91-10, October 1992.

Results Data:

Compound (g.mol.min.)	Stage I		Stage II	
	Feed	Product	Feed	Product
Ethane	1.91E-04	7.87E-05		
Oxygen	2.25E-04	1.30E-05	5.07E-5	
Nitrogen	8.45E-04	8.40E-04		
Water		1.87E-04		
Ethylene		3.41E-05	3.41E-05	
Acetic Acid		4.08E-05	4.08E-05	
CO ₂		3.53E-05		
CO		4.68E-05		
VAM				3.13E-5

The nitrogen, CO₂ and water act as diluents in stage II.

Based on the above-described catalytic data, the following general characteristics can be concluded for the methods of the invention:

1. The catalytic methods used show high selectivity to vinyl acetate by oxidizing mixtures of ethane and ethylene.
2. The catalytic methods used also show high selectivity to vinyl acetate by oxidizing ethane.
3. The catalytic method systems used produce vinyl acetate without the production of by-products such as carbon monoxide. This advantage reduces the step of CO conversion to CO₂ in the conventional VAM process.

The above description of the invention is intended to be illustrative and not limiting. Various changes or modifications in the embodiments described may occur to those skilled in the art. These can be made without departing from the spirit or scope of the invention.

What is claimed is:

[1.] A process for the production of vinyl acetate monomer comprising the steps of: (1) contacting a gaseous feed mixture of ethane or ethylene or ethane/ethylene, steam and a molecular oxygen containing gas in the presence of a first catalyst active for oxidation of ethane, ethylene or ethane/ethylene to produce a selective stream of acetic acid, ethylene, carbon dioxide and water and (2) converting a second feed mixture comprising ethylene, acetic acid and oxygen to vinyl acetate monomer in the presence of a second catalyst active for the production of vinyl acetate, wherein said process does not include an intermediate separation step to remove the CO between the two reaction steps.]

2. The process of claim [1] 3, wherein said process produces no carbon monoxide.

3. [The process of claim 2.] A process for the production of vinyl acetate monomer comprising the steps of:

(1) contacting a gaseous feed mixture of ethane or ethylene or ethane/ethylene, steam and a molecular oxygen containing gas in the presence of a first catalyst active for oxidation of ethane, ethylene or ethane/ethylene to produce a selective stream of acetic acid, ethylene, carbon

dioxide and water, wherein the first [oxidation] catalyst is selected from the following catalyst compositions:

a) a catalyst composition [comprising] *consisting of* the elements Mo, V, Nb, and Pd, in the form of oxides, in the ratio $Mo_aV_bNb_cPd_d$ wherein:

a is 1 to 5;
b is 0 to 0.5;
c is 0.01 to 0.5; and
d is >0 to 0.2;

b) a catalyst composition [comprising] *consisting of* the elements Mo, V, Pd, Nb, La and X, in the form of oxides, wherein X is Al, Ga, Si or Ge, in the ratio $Mo_aV_bLa_cPd_dNb_eX_f$ wherein:

a is 1;
b is 0.01 to 0.9;
c is >0 to 0.2;
d is >0 to 0.2;
e is >0 to 0.2; and
f is >0 to 0.3; and

c) a catalyst composition [comprising] *consisting of* the elements Mo, V, Nb and X which is selected from P, B, Hf, Te, As or mixtures thereof in the form of an oxide, in the following ratio $Mo_aV_bNb_cX_d$ wherein:

a is 1 to [S] 5;
b is >0 to 0.1;
c is 0.01 to 0.5;
d is >0 to 0.1; and

(2) *converting a second feed mixture comprising ethylene, acetic acid, and oxygen to vinyl acetate monomer in the presence of a second catalyst active for the production of vinyl acetate, wherein said process does not include an intermediate separation step to remove CO between the production of the selective stream and the converting of the second feed mixture, wherein at least a portion of the ethylene, acetic acid, and oxygen in the second feed mixture are from the selective stream.*

4. The process of claim 3, wherein said first catalyst consists essentially of catalyst composition (a), catalyst composition (b), catalyst composition (c) or mixtures thereof.]

5. The process of claim 2, wherein said first catalyst and second catalyst are in the form of a fixed or fluidized bed or a solid moving bed reactor.

6. The process of claim 2, wherein said feed mixture is fed into a second reaction zone.

7. The process of claim 6, wherein the second feed mixture for the second step comprises ethylene, acetic acid, CO₂ and oxygen.

8. The process of claim 2, wherein said feed mixture comprises molecular oxygen ranging from 0.1 to 25% by volume of the feed mixture.

9. The process of claim 2, wherein said feed mixture is diluted with N₂ in an amount ranging from 5 to 90% by volume.

10. The process of claim 2, wherein said feed mixture is diluted with steam in an amount ranging from 0 to 40% by volume.

11. The process of claim 2, wherein said feed mixture comprises from 1% to 95% by volume of ethane, ethylene or mixtures thereof.

12. The process of claim 2, wherein first step oxidation is achieved at a temperature of from 150 to 450° C., under a pressure of from 15 to 600 psi, and with a contact time between reaction mixture and the catalyst of from 0.1 to 60 seconds.

13. The process of claim 2, wherein said contacting comprises reacting ethane or ethane/ethylene with steam and oxygen or a compound capable of providing oxygen in the pres-

ence of said first catalyst in a first reaction zone to form a first product mixture comprising ethylene, oxygen, steam and acetic acid and the said first product mixture is fed into a second reaction zone wherein the ethylene and acetic acid react to form vinyl acetate in the presence of said second [reaction] catalyst.

14. The process of claim 13, wherein said first product mixture is fed directly into said second reaction zone without adding additional components.

15. The process of claim 13, wherein said first product mixture is fed into said second reaction zone with addition/adjustment of ethylene, acetic acid, oxygen or combinations thereof.

16. The process of claim 13, wherein said first product mixture is subjected to temperature and/or pressure adjustments prior to being fed into said second reaction zone.

17. A process of producing vinyl acetate monomer comprising the step of catalytically oxidizing ethane to form vinyl acetate in a single reaction zone containing a first catalyst having activity for oxidation of ethane to ethylene and acetic acid and a second catalyst having activity for oxidation of ethylene with acetic acid to vinyl acetate, wherein said first catalyst is at least one catalyst selected from the following catalyst compositions:

a) a catalyst composition [comprising] *consisting of* the elements Mo, V, Nb, and Pd in the form of oxides, in the ratio $Mo_aV_bNb_cPd_d$ wherein:

a is 1 to 5;
b is 0 to 0.5;
c is 0.01 to 0.5; and
d is >0 to 0.2;

b) a catalyst composition [comprising] *consisting of* the elements Mo, V, Pd, Nb, La and X, in the form of oxides, wherein X is Ga, Si, Al or Ge, in the ratio $Mo_aV_bLa_cPd_dNb_eX_f$ wherein:

a is 1;
b is 0.01 to 0.9;
c is >0 to 0.2;
d is >0 to 0.2;
e is >0 to 0.2; and
f is >0 to 0.3; and

c) a catalyst composition [comprising] *consisting of* the elements Mo, V, Nb and X which is selected from P, B, Hf, Te, As or mixtures thereof in the form of an oxide, in the following ratio $Mo_aV_bNb_cX_d$ wherein:

a is 1 to 5;
b is >0 to 0.1;
c is 0.01 to 0.5; and
d is >0 to 0.1.

18. The process of claim 17, wherein said single reaction zone comprises a mixture of said first catalyst and said second catalyst.

19. The process of claim 17, wherein said single reaction zone comprises layers of said first [reaction] catalyst and said second catalyst.

20. The process of claim 2, wherein said process produces ethylene, acetic acid, VAM or combinations thereof.

21. *A process for the production of vinyl acetate monomer comprising the steps of:*

(1) *contacting a gaseous feed mixture of ethane or ethylene or ethane/ethylene, steam and a molecular oxygen containing gas in the presence of a first catalyst active for oxidation of ethane, ethylene or ethane/ethylene to produce a selective stream of acetic acid, ethylene, carbon*

11

dioxide and water, wherein the first catalyst is selected from the following catalyst compositions:

a) a catalyst composition consisting of the elements Mo, V, Nb, and Pd, in the form of oxides, in the ratio $Mo_aV_bNb_cPd_d$ wherein:

a is 1 to 5;
b is 0 to 0.5;
c is 0.01 to 0.5; and
d is >0 to 0.2;

b) a catalyst composition consisting of the elements Mo, V, Pd, Nb, La and X, in the form of oxides, wherein X is Al, Ga, Si or Ge, in the ratio $Mo_aV_bLa_cPd_dNb_eX_f$ wherein:

a is 1;
b is 0.01 to 0.9;
c is >0 to 0.2;
d is >0 to 0.2;
e is >0 to 0.2; and
f is >0 to 0.3; and

c) a catalyst composition consisting of the elements Mo, V, Nb and X which is selected from P, B, Hf, Te, As or mixtures thereof in the form of an oxide, in the following ratio $Mo_aV_bNb_cX_d$ wherein:

a is 1 to 5;
b is >0 to 0.1;
c is 0.01 to 0.5;
d is >0 to 0.1; and

(2) optionally adjusting the selective stream; and converting a second feed mixture comprising ethylene, acetic acid, and oxygen to vinyl acetate monomer in the presence of a second catalyst active for the production of vinyl acetate, wherein at least a portion of the ethylene, acetic acid, and oxygen in the second feed mixture are from the selective stream;

wherein no detectable or measurable levels of CO is produced when contacting said gaseous feed mixture in the presence of said first catalyst, and wherein said process does not include an intermediate separation step to remove CO between the production of the selective stream and the converting of the second feed mixture.

22. The process of claim 21, wherein said process produces no carbon monoxide.

23. The process of claim 22, wherein said first catalyst and second catalyst are in the form of a fixed or fluidized bed or a solid moving bed reactor.

12

24. The process of claim 22, wherein said gaseous feed mixture is fed into a second reaction zone.

25. The process of claim 24, wherein the second feed mixture for the second step comprises ethylene, acetic acid, CO₂ and oxygen.

26. The process of claim 22, wherein said gaseous feed mixture comprises molecular oxygen ranging from 0.1 to 25% by volume of the feed mixture.

27. The process of claim 22, wherein said gaseous feed mixture is diluted with N₂ in an amount ranging from 5 to 90% by volume.

28. The process of claim 22, wherein said gaseous feed mixture is diluted with steam in an amount ranging from 0 to 40% by volume.

29. The process of claim 22, wherein said gaseous feed mixture comprises from 1% to 95% by volume of ethane, ethylene or mixtures thereof.

30. The process of claim 22, wherein first step oxidation is achieved at a temperature of from 150 to 450° C., under a pressure of from 15 to 600 psi, and with a contact time between reaction mixture and the catalyst of from 0.1 to 60 seconds.

31. The process of claim 22, wherein said contacting comprises reacting ethane or ethane/ethylene with steam and oxygen or a compound capable of providing oxygen in the presence of said first catalyst in a first reaction zone to form a first product mixture comprising ethylene, oxygen, steam and acetic acid and the said first product mixture is fed into a second reaction zone wherein the ethylene and acetic acid react to form vinyl acetate in the presence of said second catalyst.

32. The process of claim 31, wherein said first product mixture is fed directly into said second reaction zone without adding additional components.

33. The process of claim 31, wherein said first product mixture is fed into said second reaction zone with addition/adjustment of ethylene, acetic acid, oxygen or combinations thereof.

34. The process of claim 31, wherein said first product mixture is subjected to temperature and/or pressure adjustments prior to being fed into said second reaction zone.

* * * * *