

US00RE43773E

(19) **United States**
(12) **Reissued Patent**
Duhn

(10) **Patent Number:** **US RE43,773 E**
(45) **Date of Reissued Patent:** ***Oct. 30, 2012**

(54) **DRILLING QUICK CONNECTORS**

(75) Inventor: **Rex E. Duhn**, The Woodlands, TX (US)

(73) Assignee: **Seaboard International Inc.**, Houston, TX (US)

(*) Notice: This patent is subject to a terminal disclaimer.

(21) Appl. No.: **11/581,229**

(22) Filed: **Oct. 12, 2006**

Related U.S. Patent Documents

Reissue of:

(64) Patent No.: **6,199,914**
Issued: **Mar. 13, 2001**
Appl. No.: **09/274,857**
Filed: **Mar. 23, 1999**

U.S. Applications:

(60) Provisional application No. 60/088,586, filed on Jun. 9, 1998.

(51) **Int. Cl.**
F16L 21/00 (2006.01)

(52) **U.S. Cl.** **285/123.1; 285/123.13; 285/309; 285/404**

(58) **Field of Classification Search** **285/90, 285/920, 123.1, 123.9, 123.13, 390, 404**
See application file for complete search history.

(56) **References Cited**

U.S. PATENT DOCUMENTS

190,965 A 5/1877 Foster, Jr.
503,432 A 8/1893 McIntyre
1,122,422 A 12/1914 Ross
1,193,923 A 8/1916 Rateike

1,232,129 A 7/1917 Wafer
1,455,971 A 5/1923 Rickenbacker et al.
1,512,298 A 10/1924 Mueller
1,607,430 A 11/1926 Brewster
1,898,617 A 2/1933 Church
1,993,372 A 3/1935 Jones
2,044,302 A 6/1936 Holton
2,067,773 A 1/1937 Long
2,075,899 A 4/1937 Humason
2,112,352 A 3/1938 Vetrano
2,178,699 A 11/1939 Penick et al.
2,220,359 A 11/1940 Tschappat

(Continued)

FOREIGN PATENT DOCUMENTS

JP 05010490 A * 1/1993

(Continued)

OTHER PUBLICATIONS

Cooper Oil, Tool Division, Fastlock™ Connector, Catalog, 1992 (1 page).

(Continued)

Primary Examiner — Aaron Dunwoody

(74) *Attorney, Agent, or Firm* — Christie, Parker & Hale, LLP

(57) **ABSTRACT**

A quick connector fitting assembly is provided which includes a fitting which releasably connects to a well casing for providing an interface for the attachment of various types of well related equipment. The quick connector fitting connects using fasteners to a lip or groove formed on the casing. The fasteners can easily connect or disconnect from the groove or lip facilitating the quick connection and disconnection of the fitting from the casing.

66 Claims, 12 Drawing Sheets

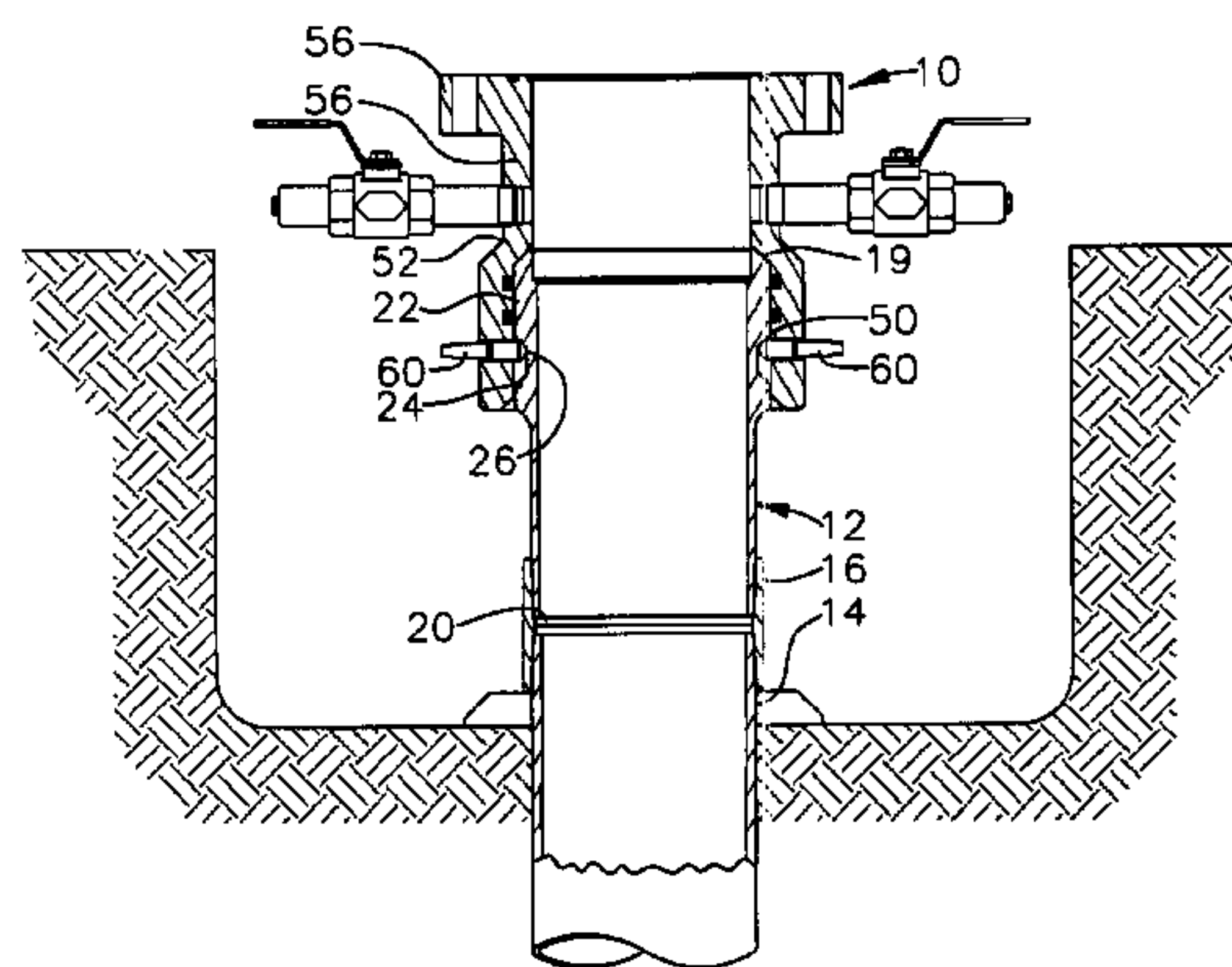
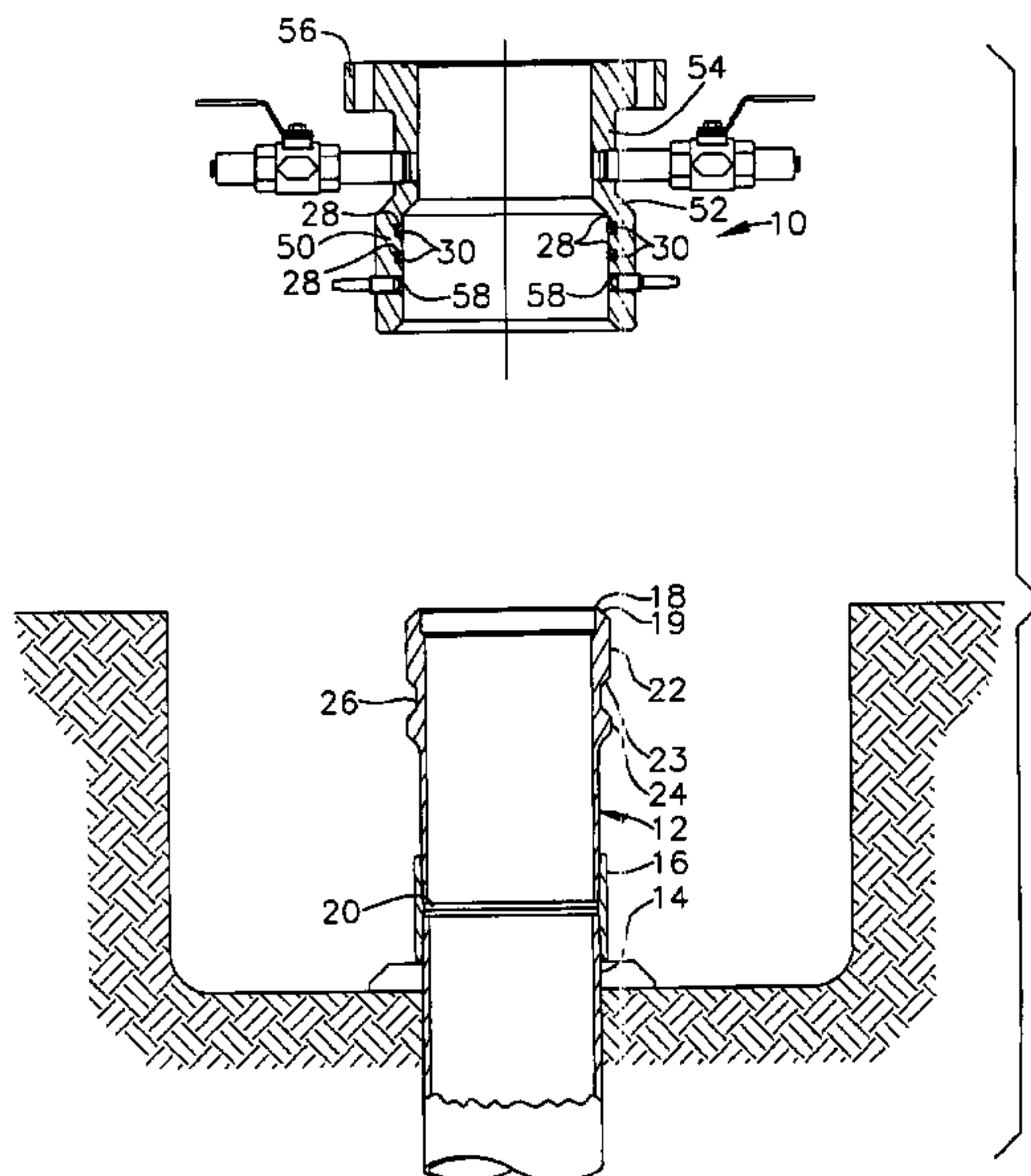

US RE43,773 E

Page 2

U.S. PATENT DOCUMENTS

2,284,869 A 6/1942 Hinderliter
2,391,632 A 12/1945 Knight et al.
2,927,642 A 3/1960 Meredith, Jr. et al.
3,177,013 A 4/1965 Rector
3,239,248 A 3/1966 Jones
3,321,217 A 5/1967 Ahlstone
3,325,190 A 6/1967 Eckert et al.
3,345,087 A * 10/1967 Hanes et al. 285/39
3,427,048 A 2/1969 Brown
3,435,895 A 4/1969 Lee
3,606,393 A * 9/1971 Huntsinger et al. 285/90
3,608,932 A 9/1971 Brown
3,827,728 A 8/1974 Hynes
3,955,835 A 5/1976 Farrington
4,056,272 A 11/1977 Morrill
4,068,865 A * 1/1978 Shanks, II 285/90
4,114,928 A 9/1978 Lochte
4,124,231 A * 11/1978 Ahlstone 285/18
4,209,193 A * 6/1980 Ahlstone 285/309
4,335,904 A 6/1982 Saliger et al.
4,402,533 A 9/1983 Ortloff
4,441,740 A 4/1984 Cowan et al.
4,452,472 A 6/1984 Crase
4,479,669 A * 10/1984 Hynes 285/332.3
4,522,430 A 6/1985 Stromberg
4,524,998 A 6/1985 Brisco

4,541,490 A 9/1985 Bigbie et al.
4,606,557 A 8/1986 Coffey
4,610,465 A * 9/1986 Boyadjieff 285/3
4,923,006 A 5/1990 Hartmann et al.
4,974,676 A 12/1990 Duhn et al.
5,141,257 A * 8/1992 Taylor 285/18
5,145,213 A 9/1992 Marrison et al.
5,149,143 A 9/1992 Howell
5,176,409 A 1/1993 Brooks
5,333,911 A 8/1994 Watkins
5,362,109 A 11/1994 Pacht
5,441,310 A 8/1995 Barrett et al.
5,611,398 A 3/1997 Duhn et al.
6,123,363 A * 9/2000 Burgard et al. 285/24
6,138,762 A 10/2000 Sweeney et al.
6,328,343 B1 * 12/2001 Hosie et al. 285/90

FOREIGN PATENT DOCUMENTS

JP 06213379 A * 8/1994

OTHER PUBLICATIONS

Huber-Hercules Wellhead Accessories, Drilling and Completion Flanges, Catalog, p. 15 (1 page).
Larkin Products, Inc., Drilling and Adaptor Flanges, Catalog, p. 15 (1 page).

* cited by examiner

FIG. 1A

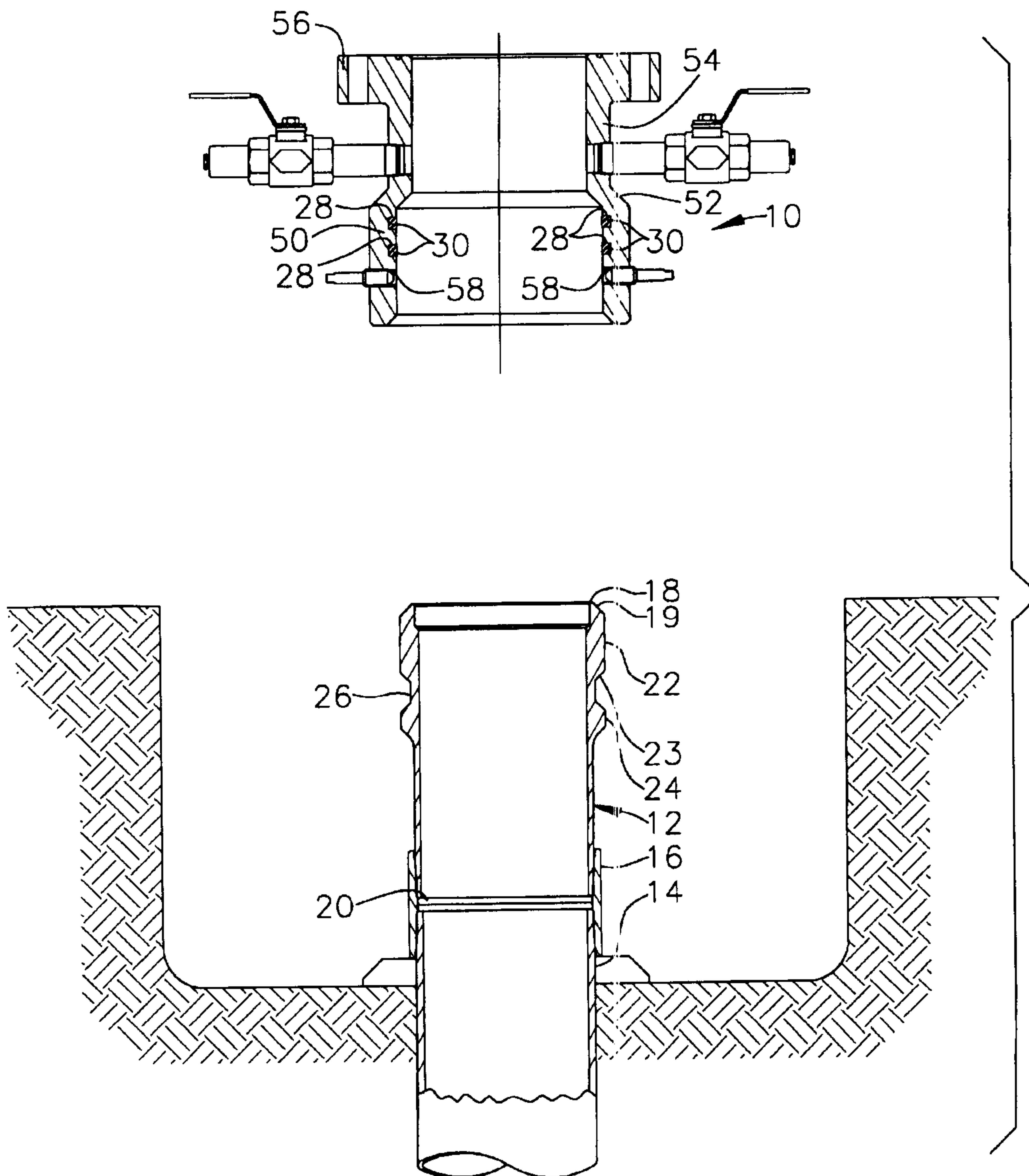

FIG. 1B

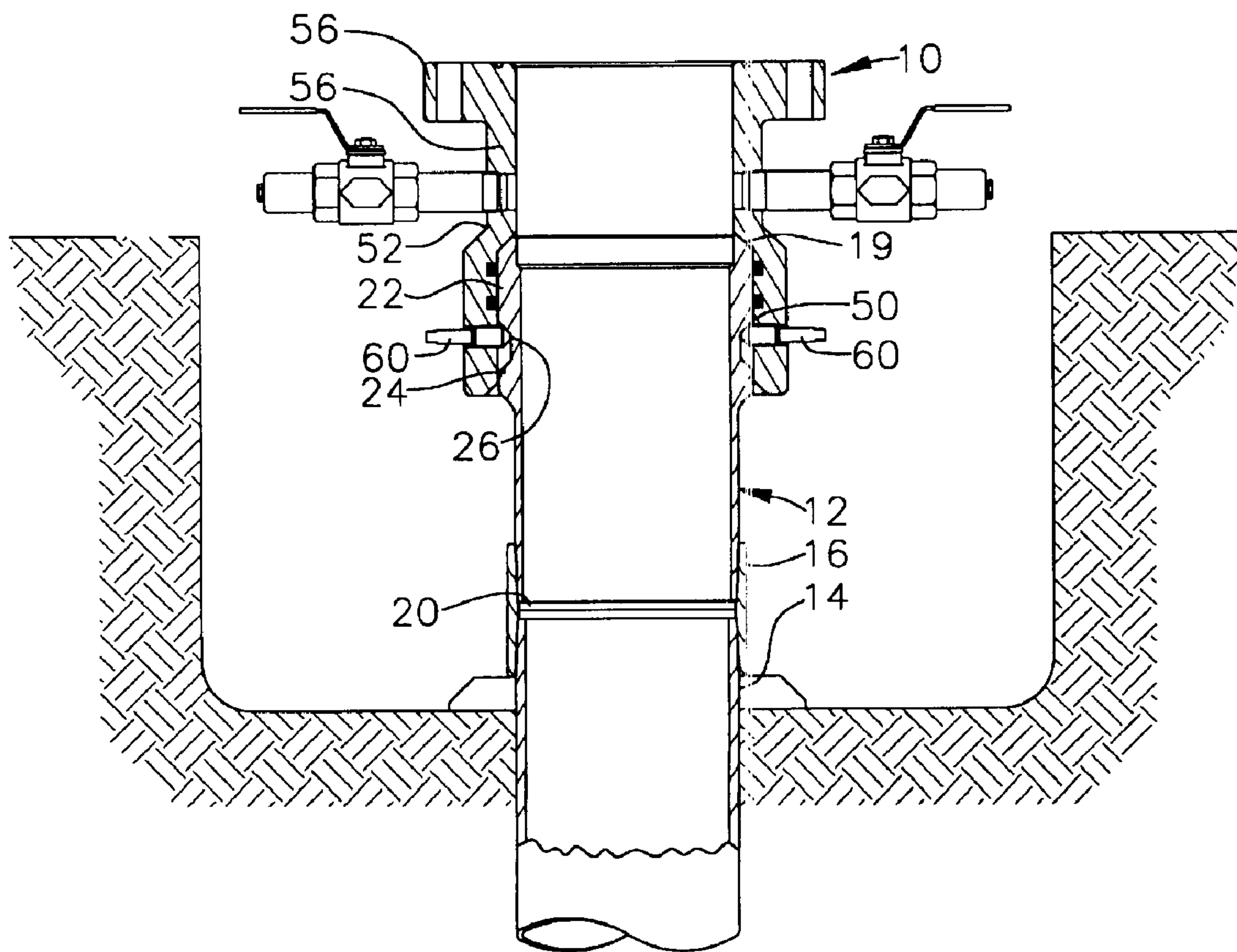

FIG. 2A

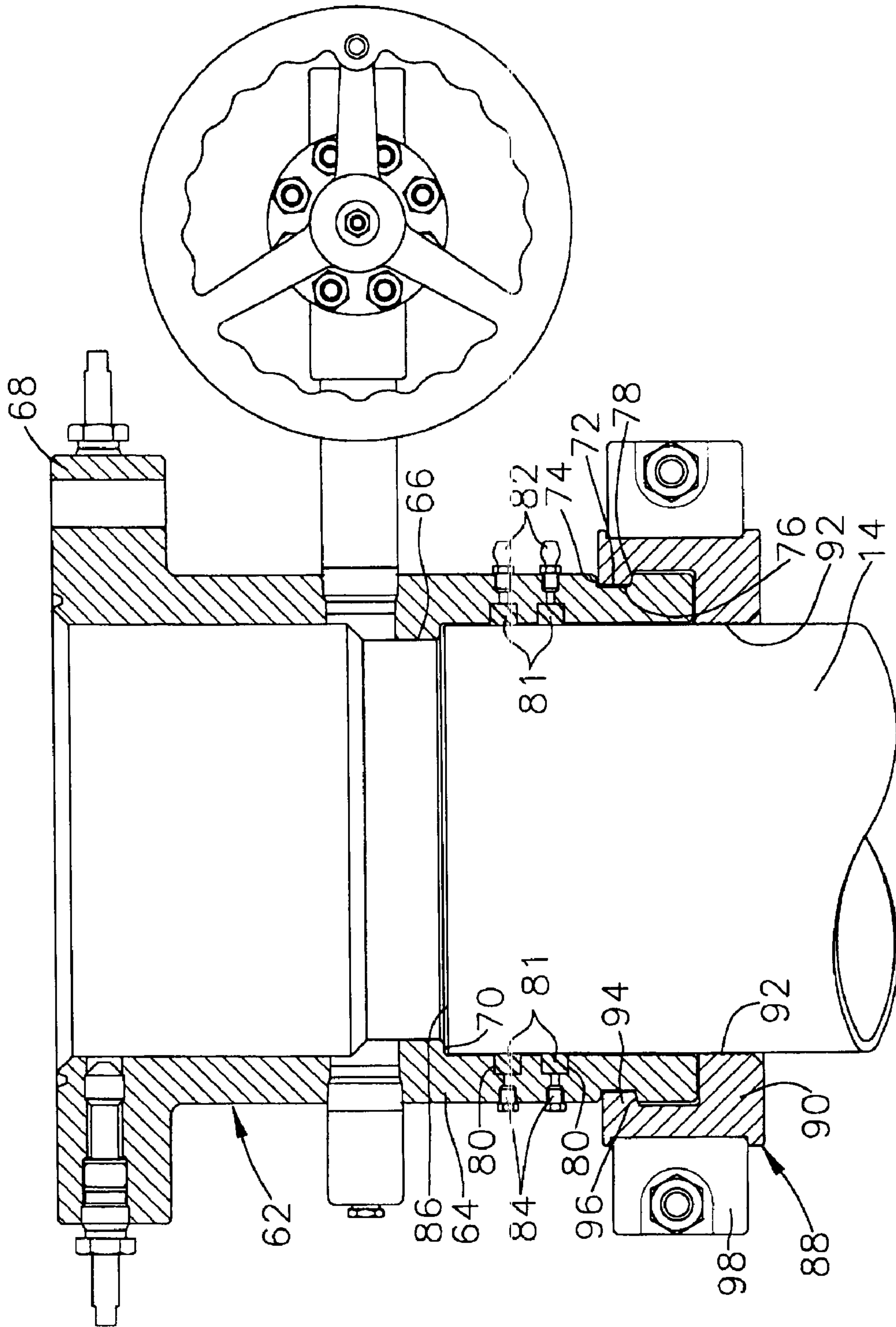
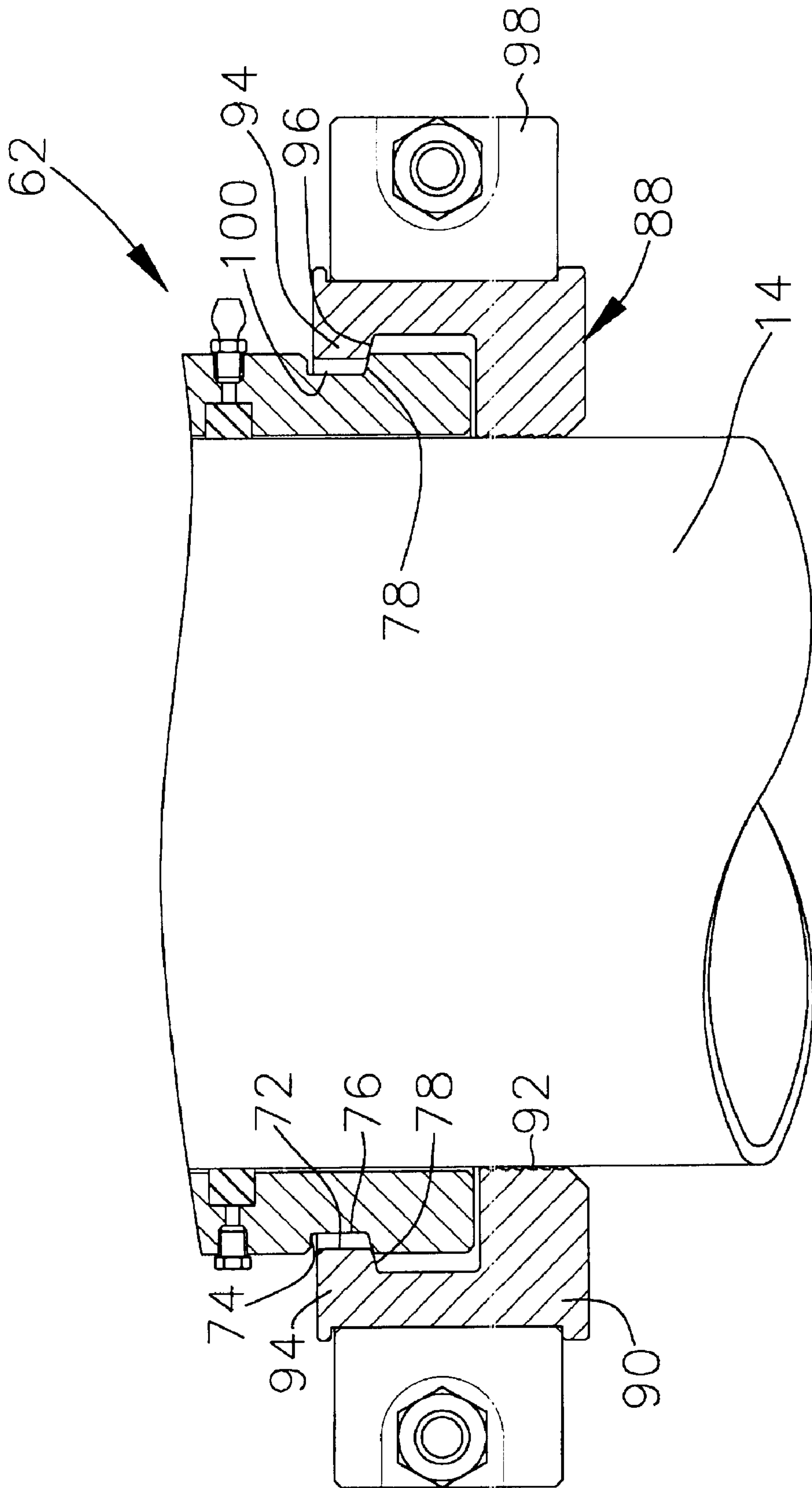
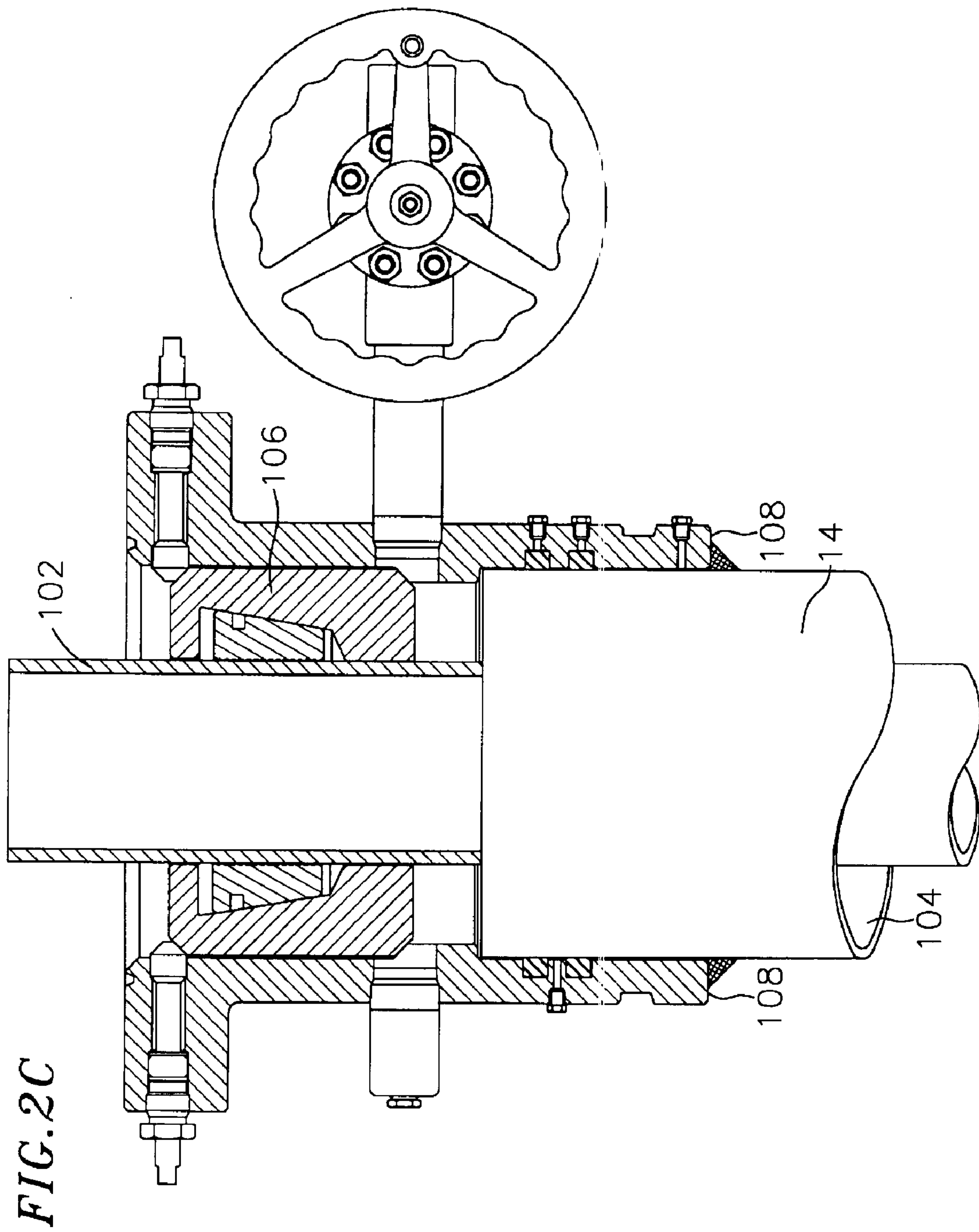

FIG. 2B





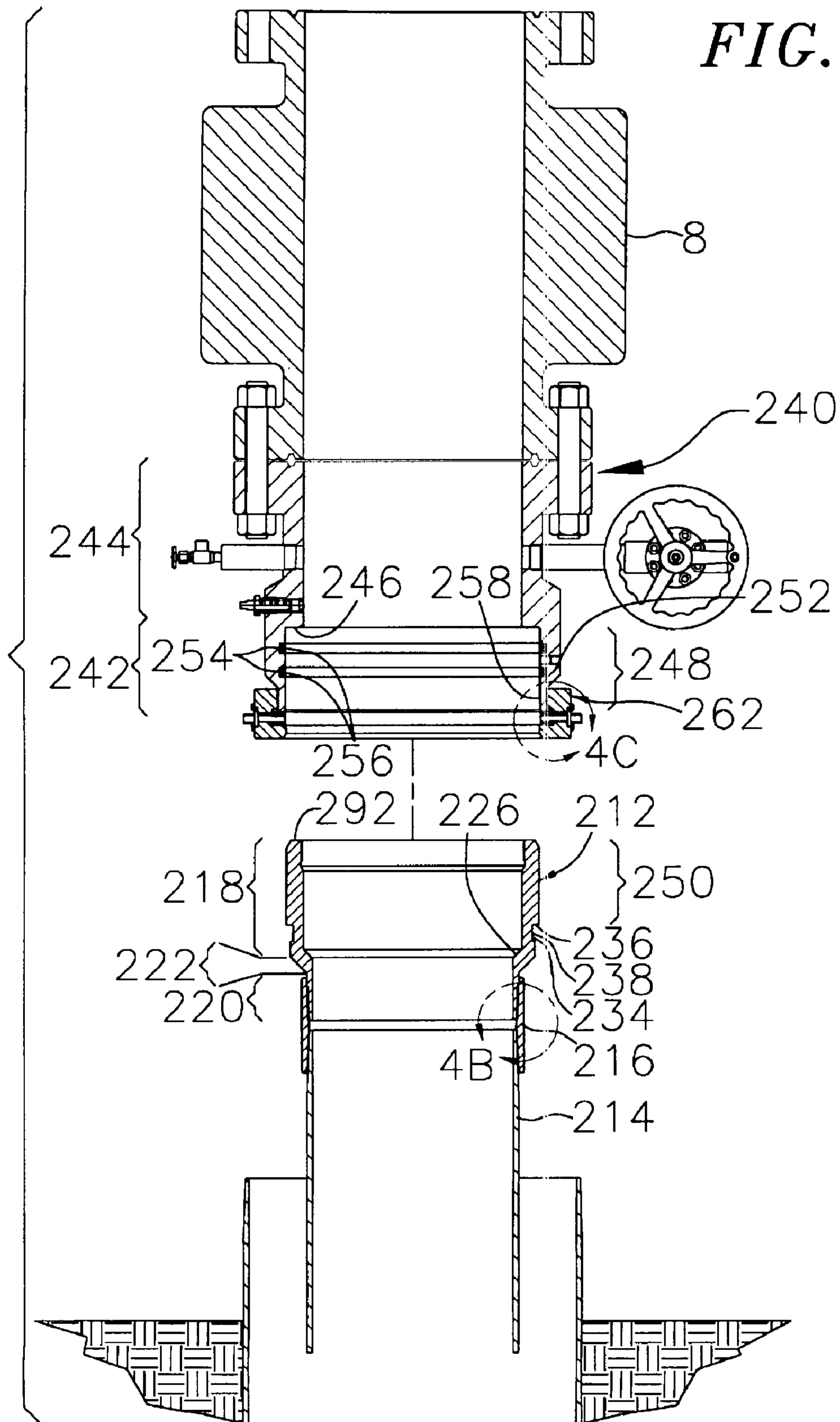

FIG. 4B

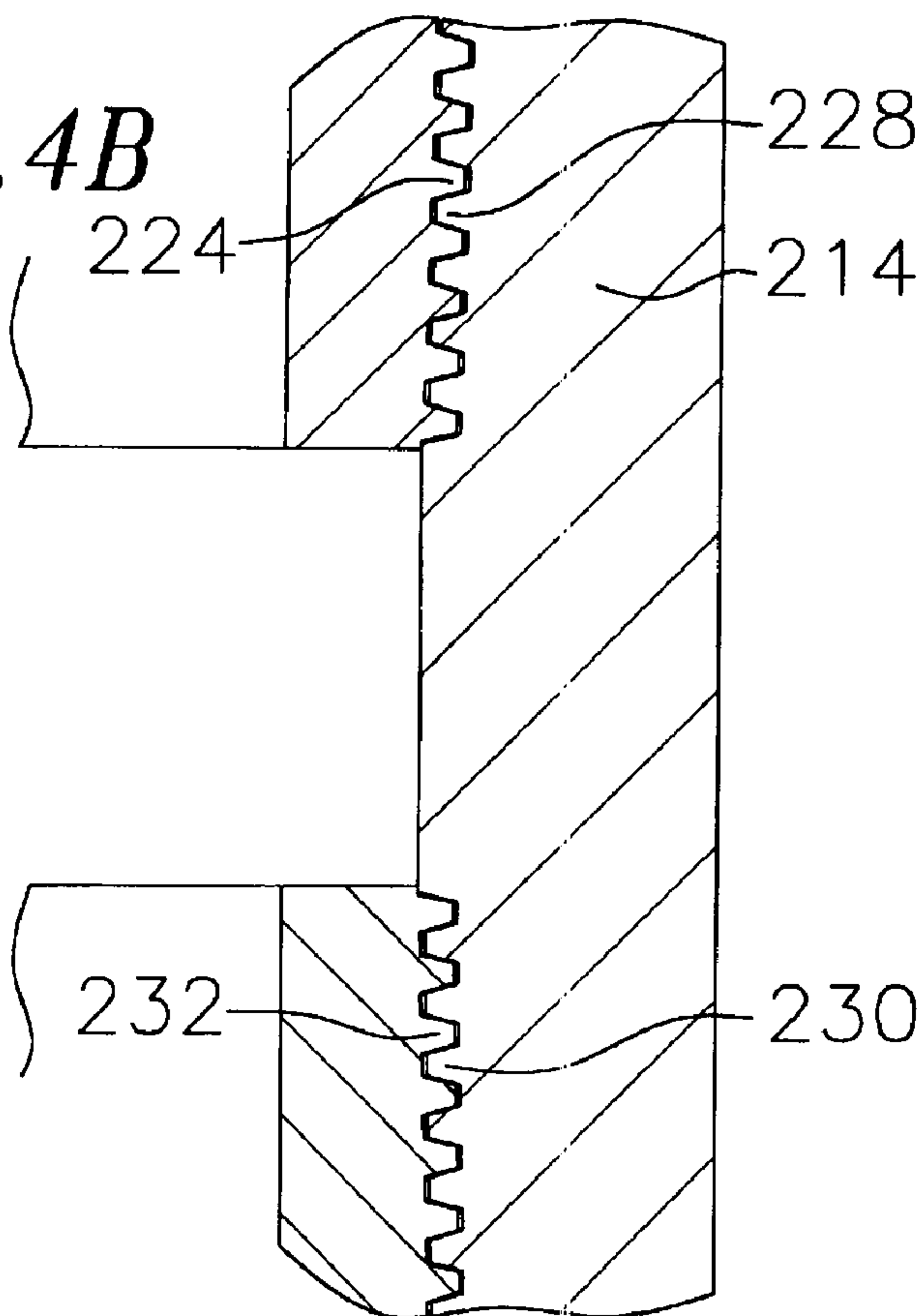

FIG. 4C

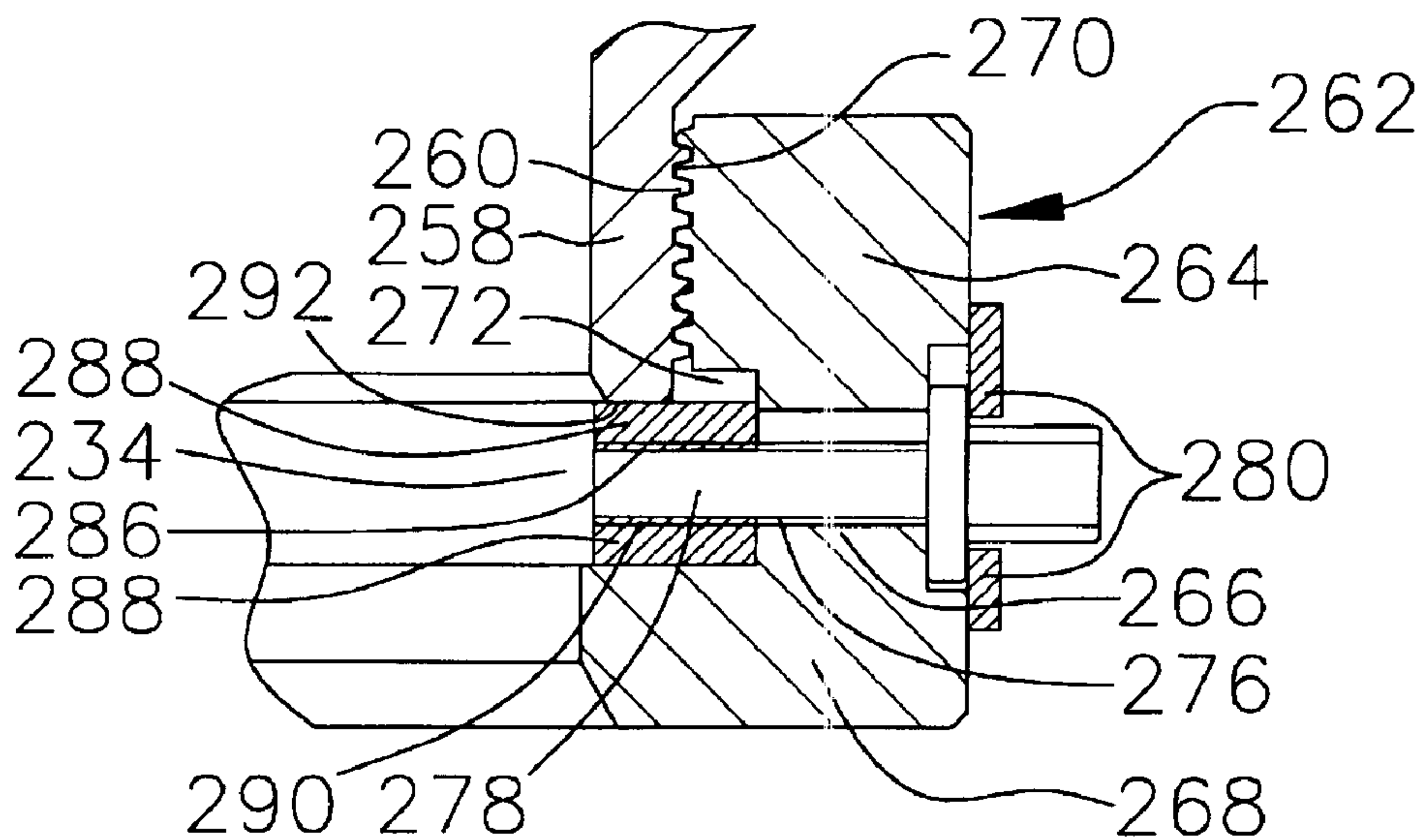

FIG. 4D

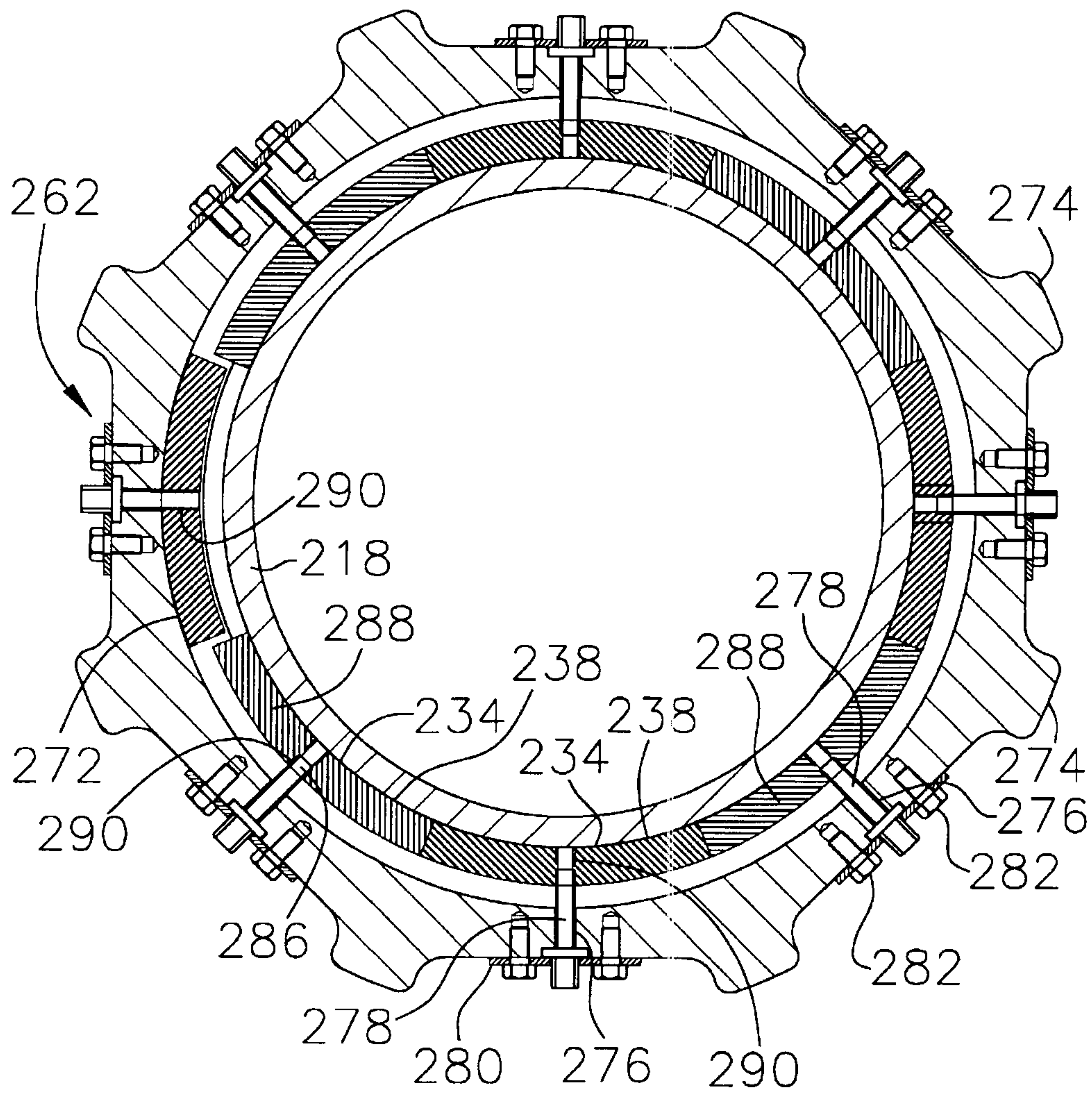

FIG. 4E

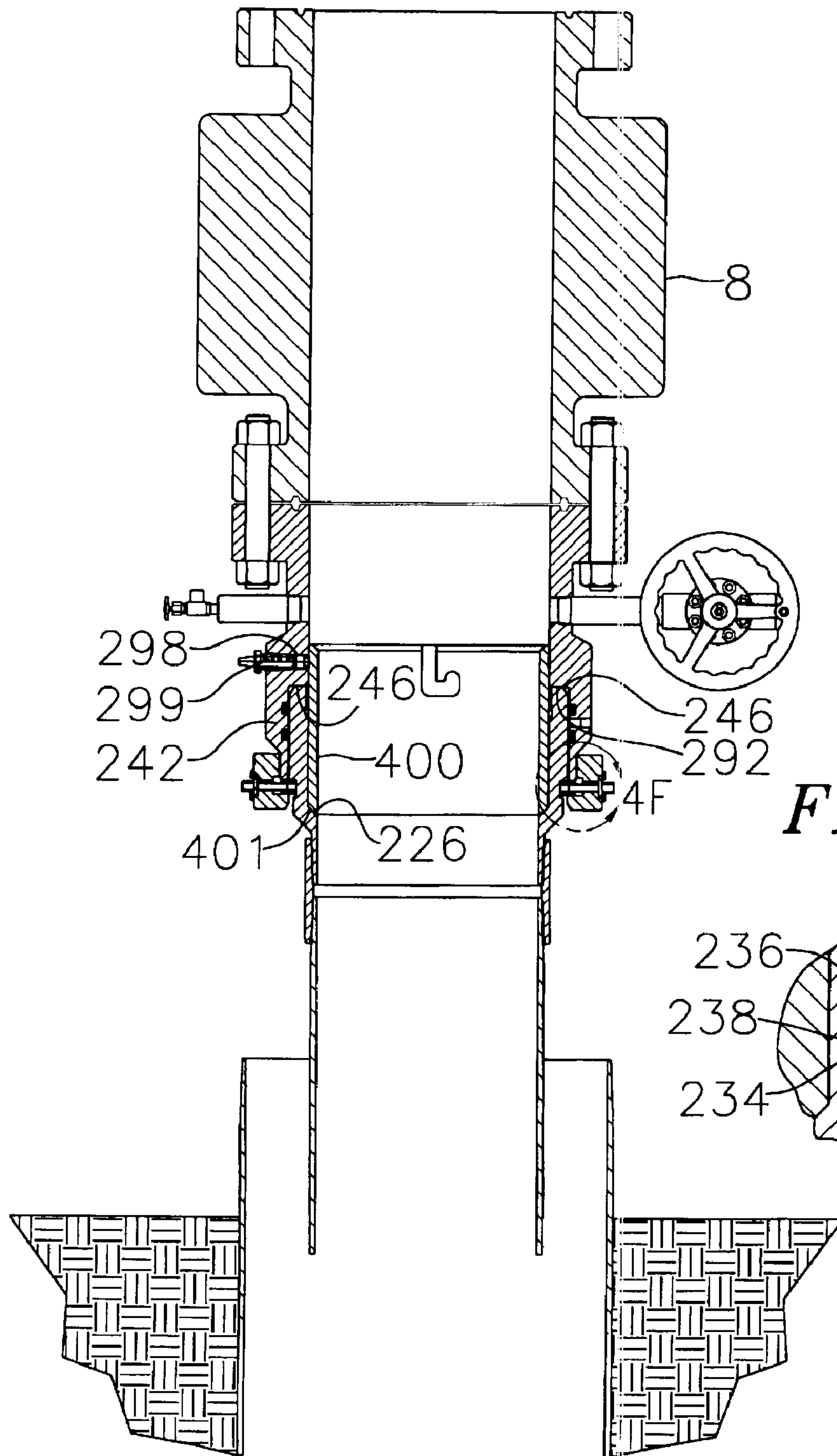
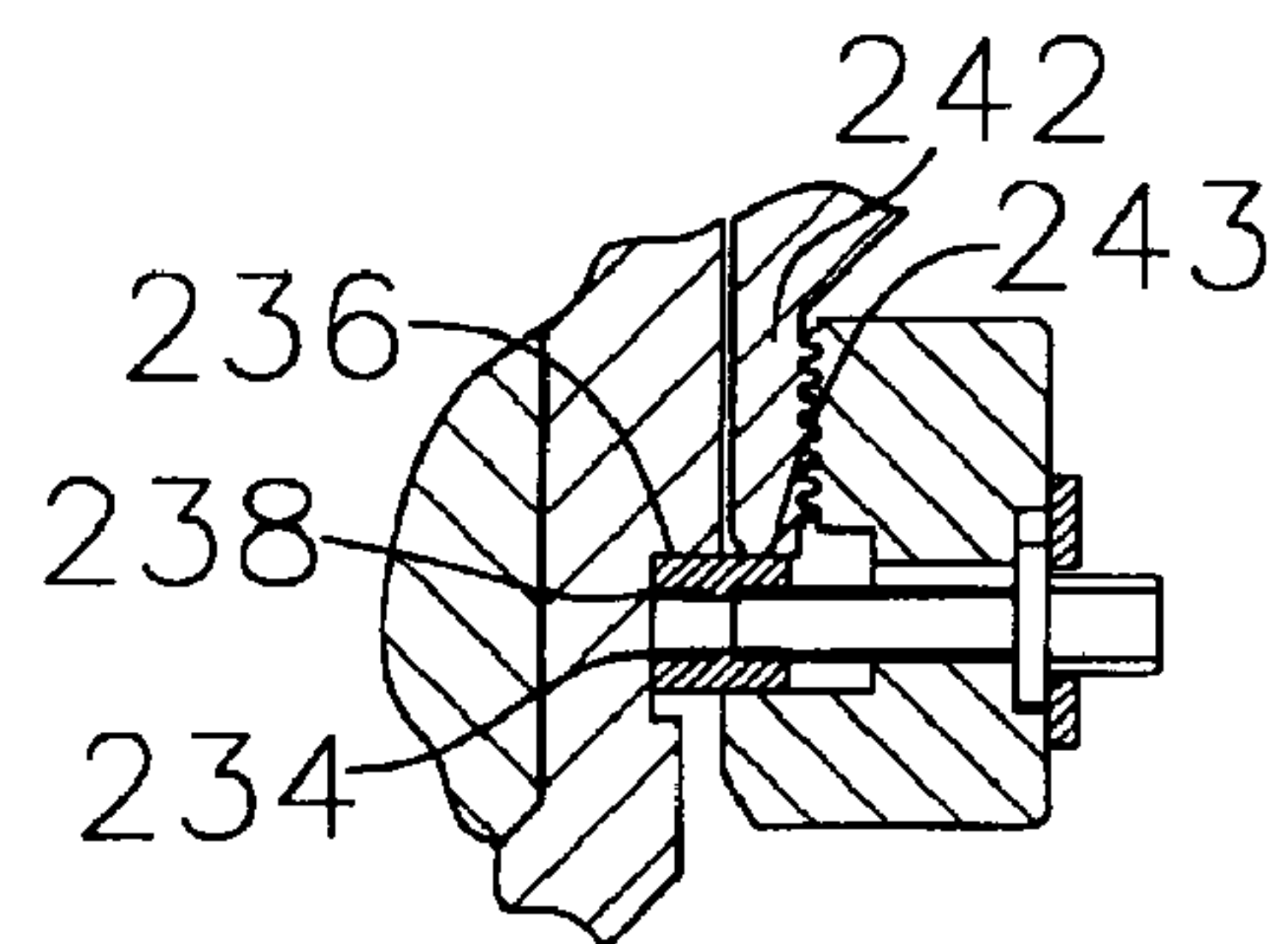

FIG. 4F



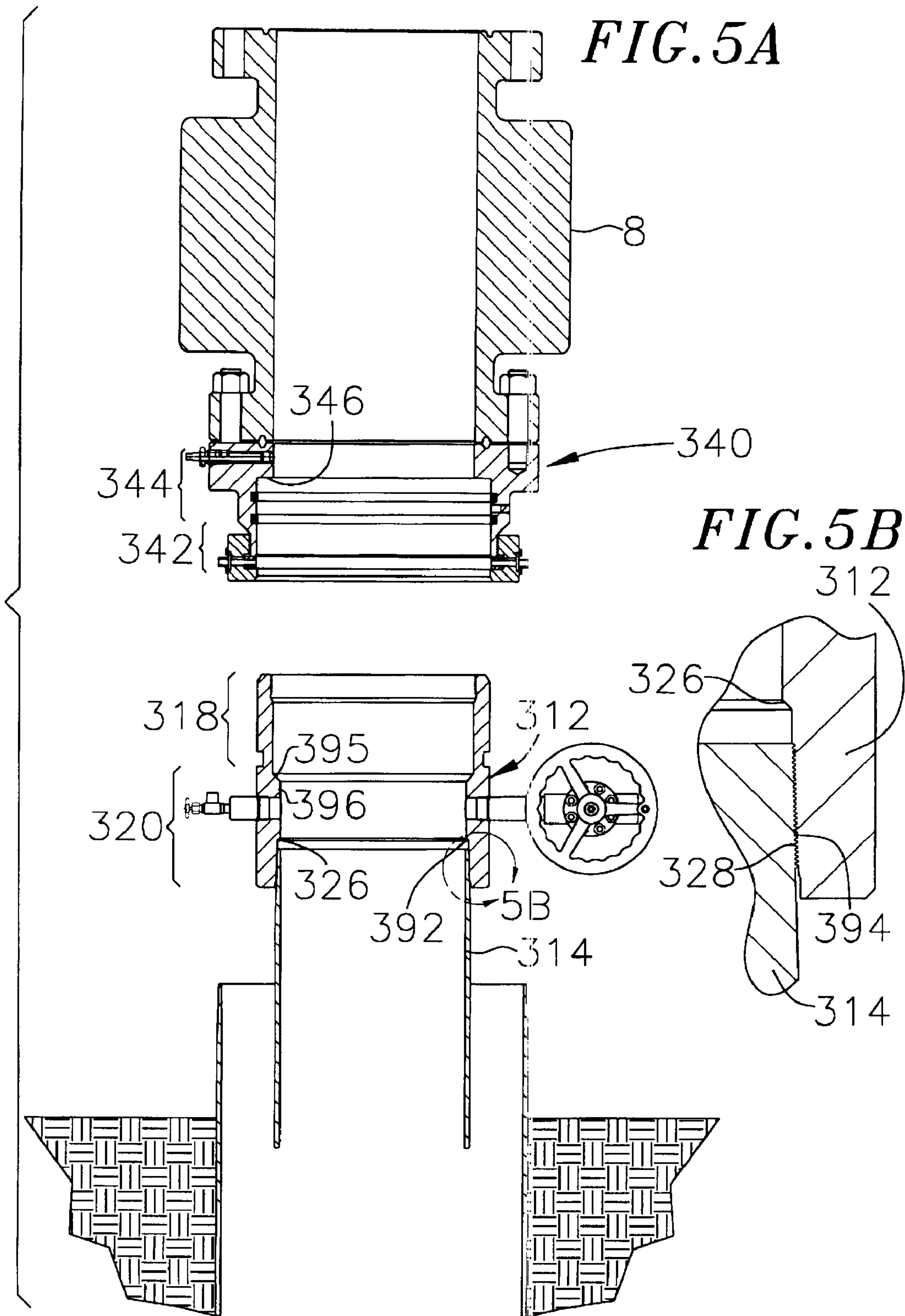
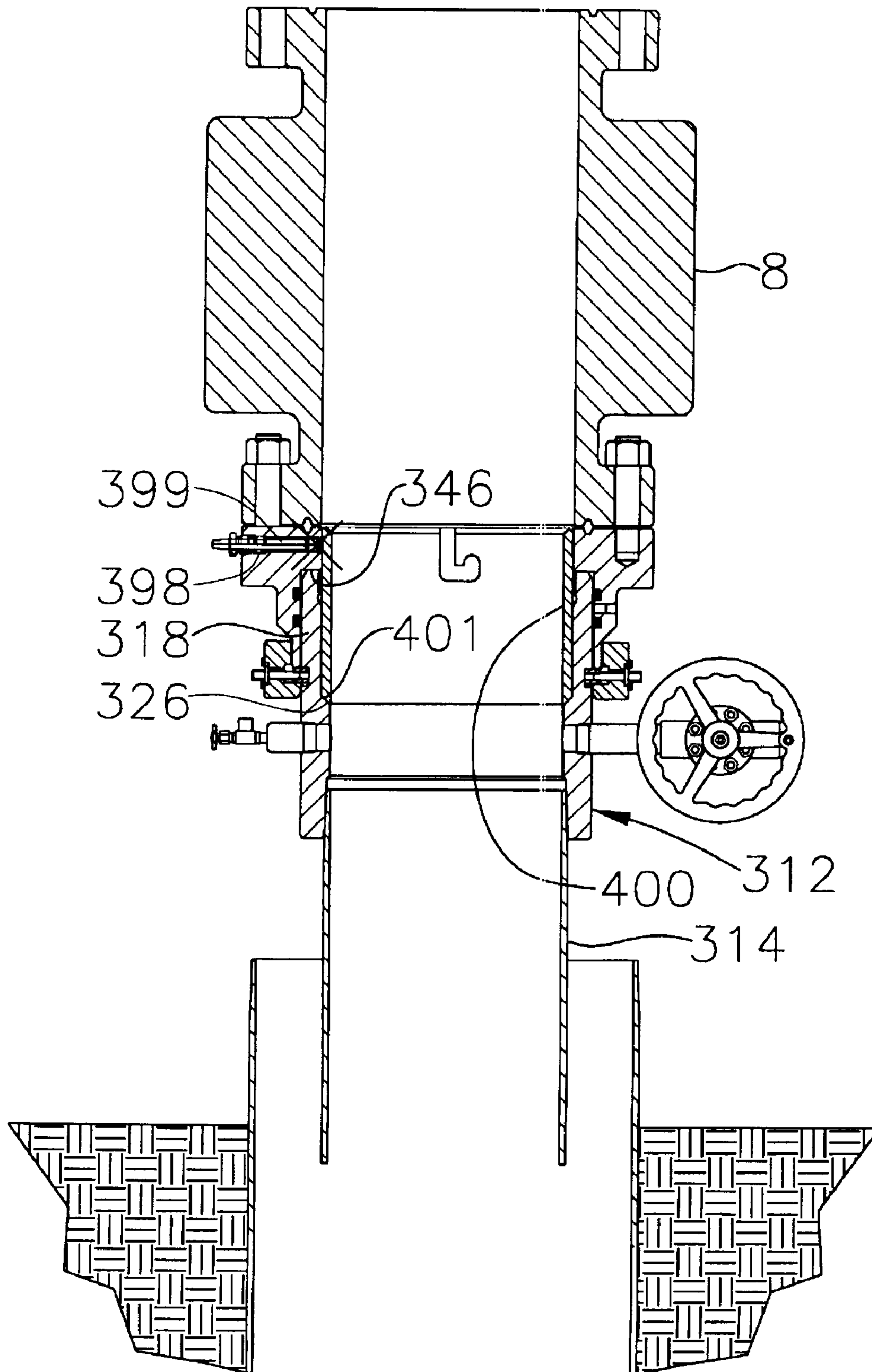

FIG. 5C



DRILLING QUICK CONNECTORS

Matter enclosed in heavy brackets [] appears in the original patent but forms no part of this reissue specification; matter printed in italics indicates the additions made by reissue.

CROSS-REFERENCE TO RELATED APPLICATION

More than one reissue application has been filed for the reissue of U.S. Pat. No. 6,199,914. The reissue applications are reissue application Ser. No. 10/325,047 filed on Dec. 20, 2002 and the present reissue application which is a divisional of reissue application Ser. No. 10/325,047.

This application claims priority and is based on Provisional Application 60/088,586 filed on Jun. 9, 1998.

BACKGROUND OF THE INVENTION

This invention relates to quick connect assemblies including quick connector fittings which quickly and releasably connect to a well casing for providing an interface for attaching well related equipment such as blowout preventors to the casing.

Fittings, such as drilling flanges, are currently used to provide an interface to well casings for mounting various equipment such as blowout preventors. A conventional fitting, such as a drilling flange, is threaded onto the casing until a shoulder within the drilling flange makes contact with the casing mouth. An elastomeric O-ring seals the drilling flange/casing interface. Once such a drilling flange is mounted on a casing, it is difficult to remove. Consequently, in many instances, the drilling flange remains permanently on the casing. As a result, on the field where multiple drilling operations may be going on at once, a separate drilling flange is required for each casing. This can be expensive.

Another problem with these flanges is that their orientation with respect to the casing cannot be accurately predetermined. The orientation depends on how tight the flange is threaded on the casing. This shortcoming poses a problem in situations where the equipment to be attached requires a specific orientation relative to the casing.

As such, a quick connect assembly is needed which provides for the easy installation and removal of a quick connector fitting so as to allow the fitting to be used on multiple casings in the field and which allows the fitting to be oriented to any desired position relative to the casing.

SUMMARY OF THE INVENTION

The present invention is directed to quick connect assemblies allowing for the quick and releasable connection of a quick connector fitting to a well casing for providing an interface for the attachment of well related drilling equipment such as blowout preventors. In a first embodiment, a male receiver is coupled to the casing. The receiver has an annular lip formed on its outer surface near its upper open end or mouth. The annular lip has a lower surface which slopes upward in a radially outward direction. A quick connector fitting has a first cylindrical section which tapers to a smaller second cylindrical section. A flange extends radially from an upper end of the smaller cylindrical section. The flange provides the interface for attaching well related equipment. The larger cylindrical section of the fitting is slid over the mouth of the male receivers. Threaded openings are formed radially

through the larger section of the fitting and are arranged circumferentially around the fitting. Lock screws are threaded through the openings to engage the lower sloping surface of the annular lip male receiver. As the lock screws are tightened, the lip sloping surface guides them downward thereby causing the fitting to seat and lock on the male receiver mouth. To remove the fitting, the lock screws are loosened.

In another embodiment, a quick connector fitting is used having an annular lip formed on its inner surface. A flange extends from an upper end of the fitting to provide the interface for attachment of the various well related equipment. The fitting lower end is slid over the casing head such that a lower surface of the annular lip is seated on the mouth of the casing. An annular groove is formed circumferentially around the outer surface of the fitting near the fitting lower end. The annular groove has a lower surface that slopes downward in a radially outward direction. A retainer slip, preferably a four piece retainer slip, having an upper and a lower annular lip is used to secure the fitting to the casing. The upper lip engages the groove, while the lower lip engages the outer surface of the casing. Teeth are formed on the face of the lower retainer slip lip that engages the casing. A clamp surrounds the retainer slip. As the clamp is tightened, it provides radial forces on the retainer slip causing the teeth formed on the lower lip to engage the casing outer surface and thus fix the position of the retainer slip relative to the casing. As the clamp is further tightened, the retainer slip upper lip engages the lower sloping surface of the groove formed on the outer surface of the fitting and causes the fitting to move downward against the casing. As a result, the annular lip formed on the inner surface of the fitting sits tightly against the casing mouth.

In yet a further embodiment, an annular bushing is threaded on the outer threads formed on the casing. Preferably the bushing is threaded downward about $\frac{1}{4}$ inch \pm $\frac{1}{8}$ inch from the casing mouth. An annular groove is formed on the outer surface of the bushing. The groove has an upper surface which slopes upward in a radially outward direction. A fitting is then fitted over the casing and the bushing. The fitting has an inner shoulder which sits on the mouth of the casing. On its opposite end, the fitting forms a flange for providing an interface for the well related equipment. Fasteners are threaded radially through the fitting to engage the upper surface annular groove. The sloping upper surface guides the fasteners downward thereby causing the fitting to tightly seat on the mouth of the casing and to lock on the bushing and thereby on the casing. Lock nuts may be threaded on the fasteners from the ends opposite the ends engaging the groove on the bushing. These lock nuts are threaded until they engage the outer surface of the fitting providing a radially outward force on the fasteners preventing them from loosening from the fitting.

In another embodiment an annular casing head is coupled to the casing. The casing head can be threaded directly to the casing or may be coupled to the casing using a coupling. An annular groove is formed on the outer surface of the casing head. The annular groove has an annular upper surface and an annular base.

A quick connector fitting is mated to the casing head. The quick connector fitting has a flange that extends from an upper end of the fitting for providing an interface for connecting well related equipment.

An annular drilling flange nut is threaded on the lower outer surface of the quick connector fitting. Load key bolts are fitted through radial openings formed on the flange nut. A retainer is used to retain each bolt on the flange nut. A preferably arc-shaped load key located inside the flange nut is threadedly engaged by each load key bolt. As a load key bolt

is turned it causes its corresponding load key to translate radially and into the groove formed on the outer surface of the casing head. The flange nut is then further torqued causing the load keys to contact and apply a force against the upper surface of the annular groove on the casing head. As result, a downward force is applied by the flange nut on the quick connector fitting causing the quick connector to further sit on the mouth of the casing head forming a tight connection.

With any of the above described embodiments, a wear bushing may be fitted such that it provides a protecting lining to the inner surface of the casing head and a portion of the quick connector inner surface extending above the casing head. Moreover, with all of these embodiments, the quick connector fittings are preferably fastened to a groove. As a result, the fittings can be oriented to any position over the casing mouth prior to being quickly and releasably connected to the casing.

DESCRIPTION OF THE DRAWINGS

FIG. 1A is an exploded cross-sectional view of a quick connector assembly including a male receiver coupled to a well casing and a quick connector fitting.

FIG. 1B is a cross-sectional view of the assembled quick connector assembly shown in FIG. 1A.

FIG. 2A is a partial cross-sectional view of an alternate embodiment quick connector.

FIG. 2B is a partial cross-sectional view of the quick connector shown in FIG. 2A prior to the tightening of a slip retainer clamp.

FIG. 2C is a partial cross-sectional view of the quick connector shown in FIG. 2A with the quick connector body welded to the casing.

FIG. 3 is a cross-sectional view of an alternate embodiment quick connector assembly incorporating a bushing.

FIG. 4A is an exploded cross-sectional view of an alternate embodiment quick connector assembly prior to the mounting of the quick connector fitting on to the casing head.

FIG. 4B is an enlarged cross-sectional view of the coupling member of the assembly shown in FIG. 4A coupling the casing head to the casing.

FIG. 4C is an enlarged cross-sectional view of the drilling flange nut of the assembly shown in FIG. 4A.

FIG. 4D is another cross-sectional view of the drilling flange nut shown in FIG. 4C.

FIG. 4E is a cross-sectional view of the assembled quick connector assembly shown in FIG. 4A.

FIG. 4F is an enlarged cross-sectional view of the drilling flange nut of the assembly shown in FIG. 4E.

FIG. 5A is an exploded cross-sectional view of another embodiment quick connector assembly.

FIG. 5B is a partial enlarged cross-sectional view of the casing head of the assembly shown in FIG. 5A threaded to a casing.

FIG. 5C is a cross-sectional view of another embodiment quick connector fitting assembly.

DETAILED DESCRIPTION OF THE INVENTION

This invention relates to quick connect assemblies which include a quick connector fitting (also referred to herein as a "quick connector") that can be mounted quickly on a well casing providing an interface for the mounting of well related equipment such as blow out preventors ("BOP"). The quick connector fittings may be used and re-used on many different casings.

In a first embodiment, the quick connect assembly comprises a quick connector fitting **10** and a male receiver **12**. The quick connector fitting **10** releasably connects to the male receiver **12** which is coupled to a well casing **14** (FIGS. 1A and 1B). The casings typically have a diameter of 13-³/₈ inches. The male receiver is typically connected to the casing using a coupling **16**. The coupling is an internally threaded cylindrical member. One end of the coupling is threaded to the external casing threads. The male receiver is then torqued to inner threads on the coupling other end.

The male receiver is typically a tubular member. The male receiver has a first end or mouth **18** for connecting with the quick connector fitting and a second end **20** for threading on the coupling. Two parallel annular lip protrusions are formed on the outer surface of the male receiver near its first end (FIGS. 1A and 1B). The first or upper lip **22** is formed around the mouth of the male receiver. The upper lip has an upper surface **19** that slopes downward in a radially outward direction. The upper lip also has a lower surface **23** that slopes upward in a radially outward direction. The second or lower lip **24** is formed below and spaced apart from the upper lip. An annular groove **26** is formed between the two lips.

The coupling **16** is threaded to the casing **14**. The male receiver is then torqued to the coupling. The male receiver may be torqued to the coupling using conventional tools such as tongs (not shown). Once the male receiver is torqued in place, the quick connector is fitted over the male receiver. The quick connector has a first larger cylindrical section **50** which tapers via a tapered section **52** to a second smaller cylindrical section **54** (FIG. 1A). A flange **56** is formed around the mouth of the second section to allow for the connection of a BOP or other well related equipment. The BOP or other well related equipment may be connected to the flange prior to installation of the quick connector to the male receiver.

The larger cylindrical section of the quick connector is placed over the male receiver such that its tapered section contacts and mates with the sloping upper surface **19** of the upper lip **22** at the mouth of the male receiver. At least two internally threaded holes **58** are formed circumferentially on the larger cylindrical section of the quick connector. When in position over the male receiver, the holes **58** are aligned with an upper portion of the groove **26** formed between the lips on the male receiver (FIG. 1B). Lock down screws **60** are then threaded through the holes and engage the lower sloping surface **23** of the upper lip. As the lock down screws are threaded farther, they ride on the sloping lower surface of the upper lip pulling the quick connector tighter against the mouth of the male receiver.

Preferably, two annular grooves **28** are formed on the inner surface of the first cylindrical section above the threaded holes **58**. A pressure or mechanically energized seal **30** is fitted in each groove. A single groove fitted with a single seal may suffice. When the quick connector is mounted on the male receiver, the seals **30** also contact the outer surface of the upper lip of the male receiver. As such, the seals form a seal against the upper lip as well as against the inner surface of the first cylindrical section of the quick connector fitting. Alternatively, the grooves **28** may be formed on the outer surface of the upper lip of the male receiver instead of the quick connector first section inner surface. The seals **30** are then seated on the grooves such that when the fitting is positioned over the male receiver, the seals will again seal against the inner surface of the first section of the quick connector and against the upper lip of the male receiver. Alternatively, the groove(s) and seal(s) may be positioned so that the seal(s) seal against the male receiver lower lip and the inner surface of the first cylindrical section of the quick connector. In a further

5

embodiment, a seal or multiple seals may be used to form a seal against the inner surface of the quick connector and the male receiver upper lip while a second seal or second set of seals may be used to form a seal between the quick connector and the male receiver lower lip.

In an alternate embodiment, a quick connector fitting **62** is used that fits directly over the outer casing **14** (FIG. 2A). This quick connector consists of a cylindrical body **64**. An inner annular lip **66** is formed on the inner surface of the cylindrical body. An outer annular flange **68** is formed on the upper end of the cylindrical body. The upper flange serves as the connection interface with the BOP or other well related equipment. An annular groove **72** is formed on the outer surface of the cylindrical body near the body lower end (FIG. 2B). In cross-section, the groove has an upper surface **74**, a base **76** parallel to the longitudinal axis of the body and a lower surface **78** that slopes downward in a radially outward direction.

One, but preferably two, spaced apart annular grooves **80** are formed on the inner surface of the body below the inner annular lip (FIG. 2A). These grooves are designed to accommodate pressure or mechanically energized seals (not shown). In an alternate embodiment, an injection fitting **82** and a pressure relief fitting **84** are fitted in the wall of the body such that they extend from the outer surface of the body to an inner groove. The injection fitting and the pressure relief fitting should be spaced preferably 180° apart. An injection and a pressure relief fitting may be incorporated for each of the inner grooves.

The quick connector is slid over the outer surface of the casing **14** until the lower face **70** of the inner lip **66** rests against the mouth **86** of the casing. In the embodiment where the inner annular grooves **80** are fitted with seals, the seals must be fitted in the grooves prior to the installation of the quick connector over the casing.

A retainer slip **88** is fitted over the quick connect. The retainer slip is preferably in four pieces, each forming a 90 degree arc. However, a two or more piece retainer slip may also be used. The retainer slip consists of a lower annular lip **90** extending radially inward. Teeth **92** are formed on the inner surface of the lower annular lip. The retainer slip also has an upper inwardly extending annular lip **94** that has a shape complementary to the shape of the groove **72** formed on the outer surface of the quick connector body. As such, the lower surface **96** of the retainer slip upper lip slopes downwardly in a radially outward direction such that it is complementary to the bottom sloped surface **78** of the annular external groove formed on the quick connector body.

A slip retainer clamp **98** is clamped around the retainer slip so as to hold all the retainer slip pieces in place. As is apparent to one skilled in the art, it may be preferable to place the retainer slip and clamp over the casing prior to the placement of the quick connector body over the casing. In this regard, when the body is fitted over the casing, the slip may be easily moved over the quick connector body and clamped into place.

Initially, the clamp is tightened just enough to hold the retainer slip pieces in place as shown in FIG. 2B. When this occurs the tip portion **100** of the retainer slip upper lip is in contact with the lower sloped surface **78** of the groove formed on the body outer surface. As the clamp is further tightened, the teeth **92** formed on the inner surface of the lower lip of the retainer slip bite onto the outer surface of the casing **14** fixing the relative position between the casing and the retainer slip. As the clamp is further tightened, it causes the lower sloped surface **96** of the upper lip of the slip to attempt to travel up the lower sloped surface **78** of the external groove. As a result, the retainer slip, which is now fixed relative to the casing, causes

6

the quick connector body to move downward and therefore the body inner lip lower surface **70** to tightly engage the mouth **86** of the casing.

If the body has injection and pressure relief fittings, a sealing material **81** may be injected into the annular grooves through the injection fittings **82** until it is relieved through the pressure relief fittings **84** to form a seal between the casing and the connector.

A production or inner casing **102** is always fitted within the casing **14** (i.e., the outer casing) forming an annulus **104** therebetween (FIG. 2C). In many situations, after drilling is completed, a predetermined amount of cement is pumped down the production casing until it exits the lower end product on casing and comes around filling and sealing the annulus.

For proper sealing, the Department of Oil and Gas ("DOG") requires that the annulus is completely filled with cement. As such, enough cement must be pumped to fill the annulus. If more cement than required to fill the annulus is pumped, the cement will stay within the bottom of the production casing creating a blockage. As such, operators are inclined to be conservative in the amount of cement pumped into the production casing. As a result, sometimes the amount of cement pumped may be insufficient and does not fill the annulus completely. In these situations, the DOG permits the use of an automatic casing hanger **106**—or with a pack-off hanger (not shown) or with a mandrel casing hanger (not shown)—fitted within the quick connector as a supplement for sealing the annulus. Automatic casing hangers, pack-off hangers and mandrel casing hangers are well known in the art. When a hanger is used for sealing, the quick connector becomes a permanent fixture of the casing and thus, cannot be used with another casing. For economic purposes, however, it is recommended that the retainer clamp **98** and retainer slip **88** are removed so that they can be re-used. In their stead, the lower edge **108** of the quick connector body is welded to the outer casing.

In a further embodiment, an annular bushing **110** is threaded hand tight on the outer threads **111** formed on the outer surface of the casing head **112** (FIG. 3). The casing head is coupled to the open end of a casing (not shown), preferably by threading. The outer bushing is preferably threaded down a distance **116** of about ¼ inch ± ⅛ inch from the casing head mouth **120**. A circumferential groove **129** is formed on the outer surface of the bushing. The groove has an upper surface **146** that slopes upward in a radially outward direction. A quick connect fitting **124** is fitted over the bushing and the casing head.

The quick connector fitting has an upper and a lower section. The lower section defined by an annular lip wall **128** which defines a first opening with a diameter slightly larger than the bushing outer surface diameter. At least two internally threaded holes **126** are defined circumferential through the wall **128**. A second opening **132** is defined in the upper section of the fitting. The second opening concentric to and in communication with the first opening and has a diameter preferably equal to the inner diameter of the mouth of the casing head. A flange **134** is formed at the mouth **136** of the upper section for mating with a BOP or other well related equipment. An internal annular shoulder **138** is formed at the interface between the upper and lower sections of the flange member. An annular groove **140** is formed on the shoulder to accommodate a pressure or mechanically energized seal **141**.

The fitting is fitted over the bushing and rotated to a desired position. When the flange is fitted over the casing head, the seal sits on the mouth **127** of the casing head. When the fitting is seated on the casing head mouth, the threaded hole **126**

centers will be located at a level aligned with an upper portion of the bushing circumferential groove. Lock down screws **142** having a threaded head **145** are then threaded through the threaded holes. The lock down screw heads have a tip portion **144** that is frusto-conical in shape having a frusto-conical surface **143**. As the lock down screws are threaded into the holes their tip portions first engage the sloping upper surface **146** of the bushing groove. As they are further threaded on the fitting they ride against the groove upper sloping surface pulling the quick connector fitting further downward and creating a tight seal between the fitting shoulder, the seal, and the mouth of the casing head. Consequently, the fitting is locked on the bushing and thereby on the casing head. Because the fitting locks against a groove (i.e., the bushing groove **146**), the fitting can be rotated and locked at any desired position.

In a further embodiment, the lock down screws **142** have a section **150** of their shaft threaded. This threaded shaft section is spaced apart from the threaded head section of the screws which engage the threaded holes **126**. A lock nut **152** is threaded on the threaded section **150** formed on the shaft of each screw after the screws have locked the fitting on the bushing. The lock nut **152** has a central threaded bore section **154** which extends into a non-threaded bore section **156**. The non-threaded bore section has a diameter larger than the threaded bore section. As the nut is screwed on the threaded shaft, its unthreaded bore section contacts the fitting annular wall **128** outer surface. As it is further screwed, it exerts a radial outward force on the screw which is threaded on the fitting wall, thereby locking the screw in place. A retainer ring **158** may then be fitted on the screw behind the nut to prevent the nut from getting lost if it were to loosen. The screw with lock nut can be preassembled with the retainer ring in place.

In another embodiment an annular casing head **212** is coupled to the casing **214** using an annular coupling member **216** (FIG. 4A). Typically the casing head has a first annular portion **218** which tapers into a second annular portion **220** via a truncated cone shaped annular third portion **222**. The first portion has an inner diameter greater than the inner diameter of the second portion. The second portion has threads **224** formed on its outer surface at its and furthest from the first portion. The inner surface of the third portion defines a shoulder **226** that slopes upward in a radially outward direction.

The coupling member **216** is a cylindrical member having inner threads. Preferably two sets of threads are formed beginning on the inner surface of the coupling member, one set at either end. The first set of threads **228** are matched to the outer threads **224** formed on the second portion of the casing head (FIG. 4B). The second set of threads **230** are matched to the outer threads **232** on the casing. The coupling through its second set of threads is threaded on the outer threads of the casing. The casing head is then threaded onto the first set of the coupling threads.

An annular groove **234** is formed on the outer surface of the first portion of the casing head near the intersection of the first portion with the truncated cone shaped portion. The annular groove has an annular upper surface **236** and an annular base **238**.

A quick connector fitting **240** is then mated to the casing head. The quick connector fitting has a first section **242** which extends into a second section **244** forming an inner annular shoulder **246** at interface between the first and second section inner surfaces. In other words, the fitting first section has an inner diameter is larger than the inner diameter of the second section. The length of the first section as measured from the annular shoulder should be slightly less than the length **250**

measured from the mouth of the casing head to the upper surface of the annular groove. A flange extends from the end of the second section opposite the first section providing an interface for connecting well related equipment.

Preferably two annular grooves **254** are formed on the inner surface of the first section, preferably on the upper thicker wall portion of the section. A flange seal **256**, which is typically an O-ring seal, is fitted into each groove. An annular wall **252** defines the fitting first section. The annular wall **252** is thinner at the open or lower end of the first section. However, the inner diameter of the first section is constant throughout the length of the section. Threads **260** are formed on the outer surface of the lower thinner portion **258** of the fitting first section.

An annular drilling flange nut **262** has an annular upper section **264**, an annular intermediate section **266** and an annular lower section **268** (FIGS. 4A and 4C). The inner surface diameter of the upper section is smaller than the inner surface diameter of the intermediate section and greater than the inner surface diameter of the lower section. The inner surface diameter of the lower section should preferably be at least slightly larger than the outer surface diameter of the casing head first section **218**. The three sections form an annular channel **272**. Threads **270** are formed on inner surface of the upper annular section matched to the threads **260** on the outer surface of the lower portion **258** of the fitting first section.

The outer surface of the drilling flange nut **242** preferably has an octagonal shape providing grip **274** areas for torquing on to the fitting using a wrench or a hammer (FIG. 4D). Radial openings **276** are formed equidistantly through the nut outer surface penetrating the nut intermediate section and exiting on the annular channel **272** formed on the inner surface of the flange nut. The openings are formed to accommodate load key bolts **278**. Each load key bolt is rotatably connected to a retainer **280**. The retainer is perpendicular to the load key bolt. Each load key bolt can rotate relative to, but cannot longitudinal translate through, its corresponding retainer. The load key bolts are fitted through the radial opening **276** on the flange nut and the retainer **280** is bolted on the outer surface of the flange nut using retainer bolts **282**.

A tip portion **286** of each load key bolt shaft extending radially beyond its corresponding radial opening **276** is threaded. Each load key bolt is able to freely rotate relative to its corresponding opening **276** formed on the flange nut. An arc shaped load key **288** is threaded to each threaded shaft portion **286**. In a preferred embodiment, eight load keys are used, one for each load key bolt. Each load key is an eighth of a ring section. The load key bolt is threaded to a threaded opening **290** formed on the center section of the load key causing the load keys to translate radially outward and rest against the annular channel **272** formed on the flange nut.

The inner surface diameter of the quick connector first section **242** is slightly greater than the outer surface diameter of the casing head first portion **218**. The quick connector is slid over the casing head until the annular shoulder **246** sits on the mouth **292** of the casing head (FIG. 4E). When at this position, the lowest end **243** of the fitting first section **242** extends almost to the upper surface **236** of the annular groove formed on the outer surface of the casing head. The fitting is rotated in relation to the casing head to a desired orientation.

The flange nut is then threaded to the outer threads **260** formed on the first section of the fitting. The flange nut may also be pre-threaded on the first section of the fitting prior to mounting the fitting over the casing head. When the flange nut is threaded on the fitting, the load keys are sandwiched between the lower portion **288** of the flange nut **262** and the lower end **243** of the fitting first section.

The flange nut is threaded sufficiently for aligning the load keys with the groove 234 formed on the outer surface of the casing head. Each load key bolt is then rotated causing its respective load key to unthread from the load key bolt and travel radially inward into the groove 234 formed on the casing head (FIG. 4D). The load keys bolts are rotated until the load keys stop against the base 238 of the casing head groove without exerting a force on the groove. When in that position, preferably, all the load keys abut each other forming a continuous ring.

The flange nut is then further torqued on the lower portion of the fitting first section causing the load keys to contact and apply a force against the upper surface 236 of the annular groove 234 on the casing head (FIG. 4F). As result, a downward force is applied by the flange nut on the quick connector first section causing the quick connector to further sit on the mouth 292 of the casing head forming a tight connection.

In an alternate embodiment, a casing head 312 is directly threaded on to the casing 314 (FIGS. 5A and 5C). With this embodiment, the casing head has a first portion 318. A second portion 320 extends below from the first portion. Threads 394 are formed in the lower inner surface of the second portion. These threads are matched to threads 328 formed on the outer surface of the casing head allowing for the torquing of the casing head to the casing (FIG. 5B). An annular lip 396 is formed on the inner surface of the second portion. The annular lip forms an upper shoulder 395 that slopes upward in a radially outward portion direction. In addition, the annular lip forms a lower annular shoulder 326. The quick connector fitting 340 mates with the casing head as described above in relation to the previous embodiment. The quick connector fitting also has a first section 342 which extends into a second section 344 forming an inner annular shoulder 346 at the interface between the first and second section inner surfaces.

With any of the above described embodiments, a wear bushing 400 (FIGS. 4E and 5C) may be fitted such that it lines the inner surface of the casing head first portion 218, 318 and a portion of the quick connector inner surface extending above the casing head first portion. When in position, typically, the bottom edge 401 of the wear bushing which is sloped mates with and rests against the sloping shoulder 226, 326 formed on inner surface of the casing head. Preferably, a threaded hole 298, 398 is formed radially through the second section 244, 324 of the quick connector fitting near the fitting inner shoulder 246, 346. When the wear bushing is properly seated, the threaded hole provides access to an outer surface of the bushing. A lock screw 299, 399 is threaded through the threaded hole for engaging and locking the wear bushing in place.

With any of the aforementioned embodiments, the BOP 8 (FIGS. 4A, 4E, 5A, 5C) or other well related equipment is connected, typically by fasteners, to the fitting. In this regard, the BOP or other well related equipment can be easily connected to or disconnected from the well casing.

Although the present invention has been described and illustrated to respect to multiple embodiments thereof, it is to be understood that it is not to be so limited, since changes and modifications may be made therein which are within the full intended scope of this invention as hereinafter claimed.

What is claimed is:

[1. A quick connect assembly for providing an interface for the attachment of equipment to a well casing, the assembly comprising:

- a tubular male receiver comprising,
- a first end for coupling to the well casing,
- a second end forming a mouth, and

a first annular lip formed around the second end, the annular lip having a lower surface sloping upward in a radially outward direction; and

a fitting mounted over the second end of the male receiver, the fitting comprising,

a first section having a cylindrical inner surface having a diameter at least as large as the outer surface diameter of the annular lip,

a second section over the first section,

a surface at an upper end of the second section for interfacing with the equipment to be mounted,

at least a threaded opening formed radially through the first section, and

a fastener threaded through the opening and having a frusto-conical tip portion for engaging the lower sloping surface of the first lip for pulling the fitting against the male receiver and for fastening the fitting to the male receiver.]

[2. An assembly as recited in claim 1 further comprising a seal between the annular lip and the first section.]

[3. An assembly as recited in claim 1 further comprising a second annular lip formed around the outer surface of the male receiver below and spaced apart from the first lip forming a groove therebetween.]

[4. An assembly as recited in claim 3 further comprising at least one depression on the second annular lip for accepting a torque tool for torquing the male receiver to the coupling.]

[5. An assembly as recited in claim 1 further comprising a coupling member for coupling the male receiver to the casing, wherein the coupling member comprises inner threads for threading to an outer surface of the well casing and to the outer surface of the male receiver.]

[6. An assembly as recited in claim 1 wherein the fitting further comprises intermediate section between the first and second sections, wherein the intermediate section has a frusto-conical inner surface and wherein the annular lip comprises an upper surface sloping downward in a radially outward direction, wherein the frusto-conical inner surface is complementary to the lip upper surface.]

[7. An assembly as recited in claim 6 wherein the annular lip lower surface slopes upwards in a radially outward direction, and wherein threading of the fastener on the threaded opening causes the fastener to engage the sloping lower surface of the lip, wherein as the fastener is further threaded the lip lower surface guides the fastener downward causing the fitting to move downward and the frusto-conical inner surface to engage the complementary upper surface of the lip.]

[8. An assembly as recited in claim 1 wherein the fitting comprises four radially threaded openings through the second section and wherein the assembly comprises four fasteners threaded through the openings and engaging the lower surface of the lip.]

9. A quick connect assembly for providing an interface for the attachment of equipment to a well casing, the assembly comprising:

an annular fitting having an inner and an outer surface for fitting over a well casing, comprising,

a surface at a top end of the fitting for providing an interface for the equipment to be mounted,

an annular surface extending from the inner surface for engaging the casing [mouth], and

an annular groove formed on the outer surface near a lower end of the fitting, the groove having an upper surface, a lower surface and a side surface therebetween;

an annular retainer slip comprising,

11

an upper annular lip extending radially inward for fitting within the fitting annular groove, and
 a lower annular lip *below said upper annular lip and* extending radially inward and having an annular edge comprising a surface *comprising teeth* for frictionally engaging an outer surface of the casing; and
 a clamp surrounding the retainer slip for compressing the retainer slip toward the casing.

10. An assembly as recited in claim 9 further comprising: an inner annular groove formed on the inner surface of the fitting below the fitting annular surface; and
 an annular seal within the inner annular groove.

11. An assembly as recited in claim 10 further comprising: a second annular groove formed on the inner surface of the fitting below the first annular groove; and
 a second annular seal within the inner annular groove.

[12. An assembly as recited in claim 10 further comprising an injection fitting extending from the outer surface of the fitting and providing access to the annular groove for injecting the groove with a sealing material.]

[13. An assembly as recited in claim 10 wherein the retainer slip lower annular lip surface for engaging the outer surface of the casing comprises teeth.]

[14. An assembly as recited in claim 13 wherein the retainer slip comprises at least two sections and wherein the fitting outer annular groove has a bottom surface that slopes downward in a radially outward direction, wherein the retainer slip upper lip has a bottom surface that slopes downward in a radially outward direction, wherein as the clamp is tightened around the retainer slip it causes the teeth on the bottom lip to engage the outer surface of the casing fixing the retainer slip relative to the casing, wherein further tightening of the clamp causes the retainer slip upper lip bottom surface to ride on the fitting annular groove bottom surface causing the fitting to move downward and the fitting inner lip to seat on the casing.]

[15. A quick connect assembly for providing an interface for the attachment of equipment to a well casing having a mouth and outer threads, the assembly comprising:

an annular bushing for threading on a well casing, the bushing having an outer surface and comprising, and a depression on the outer surface;

a fitting mounted over the bushing, the fitting having a central opening and comprising,

an annular shoulder formed around the central opening for seating on the mouth of the casing,

an annular wall extending downward from the shoulder having an inner surface diameter not less than the outer surface diameter of the bushing, and a radially threaded bore aligned with the depression, and

a surface at an upper end of the fitting for interfacing with the equipment; and

a fastener having outer threads matched to the threads on the radial bore, wherein the fastener is threaded through the threaded bore and extends into the depression for fastening the fitting to the bushing and thereby the casing.]

[16. An assembly as recited in claim 15 further comprising: an annular groove formed on the shoulder; and
 an annular seal seated in the groove.]

[17. An assembly as recited in claim 15 wherein the depression formed on the outer surface of the bushing is an annular groove.]

[18. An assembly as recited in claim 17 wherein the groove has an upper surface sloping upward in a radially outward direction, wherein the fastener has a head having a tip having a frusto-conical shaped surface, wherein as the fastener is

12

threaded on the threaded bore a frusto-conical surface of the tip engages the upper surface of the groove guiding the fastener in a downward direction and thereby causing the fitting to move downward for sitting on the mouth of the casing.]

[19. An assembly as recited in claim 18 comprising: a plurality of threaded bores formed on the annular wall aligned with the annular groove; and
 a plurality of fasteners for threading into the threaded bores for engaging the groove.]

[20. An assembly as recited in claim 19 wherein each fastener further comprises a shaft extending from the tip and having a threaded section, wherein the assembly further comprising lock nuts having inner threads matched to the threads of the threaded section, wherein each nut is threaded on the shaft from an end opposite the tip, wherein the nut contacts the annular wall and exerts a radially outward force on the fastener.]

[21. An assembly as recited in claim 20 further comprising a retainer behind the shaft threads on each fastener for preventing the lock nuts from sliding off the fastener shafts.]

[22. A method for removably connecting a fitting to a well casing having a mouth and external threads allowing for the attachment of well related equipment, the method comprising the steps of:

threading a bushing on the external threads of the casing, the bushing having an outer depression;

mounting a fitting over the bushing and well head, the fitting providing an interface for mounting well related equipment; and

fastening the fitting against the depression on the bushing.]

[23. A method as recited in claim 22 wherein the depression on the bushing is an annular groove, the method further comprising the step of orienting the fitting to a desired position over the bushing and casing prior to the step of fastening.]

[24. A method as recited in claim 23 wherein the step of fastening comprises the step of threading fasteners through the fitting to engage the groove.]

[25. A method as recited in claim 24 further comprising the step of threading a nut on a fastener from end opposite an end engaging the groove for contacting the fitting and preventing the loosening of the fastener from the fitting.]

[26. A method as recited in claim 22 wherein the step of fastening comprises the step of pulling the fitting toward the casing for seating on the mouth of the casing.]

[27. A method as recited in claim 26 wherein the step of fastening further comprises the step of forming a seal between the fitting and the mouth of the casing.]

[28. A method as recited in claim 22 wherein the step of threading comprises the step of threading the bushing to a location about $\frac{1}{8}$ inch to $\frac{3}{8}$ inch below the mouth of the casing.]

[29. A quick connect assembly for providing an interface for the attachment of equipment to a well casing, the assembly comprising:

a casing head comprising,
 a first portion forming a mouth and having an outer surface diameter;

a second portion for coupling to the well casing, and
 a groove formed on the outer surface of the casing head;

a fitting mounted over the first portion of the casing head, the fitting comprising,

a first section mounted over the first portion of the casing head, the fitting first section comprising a lower annular edge,

a second section extending over the first section and having a surface for interfacing with the equipment to be mounted;

13

an annular flange nut releasably coupled to the fitting and having a channel formed on its inner surface; and a plurality of lock keys located in the channel and moveable to a position within the groove on the outer surface of the casing head for engaging a surface of the groove and the first section lower annular edge.]

[30. An assembly as recited in claim 29 wherein the annular flange nut comprises:

an upper annular section coupled to the fitting;
an intermediate section extending from the upper section and having an inner surface diameter larger than the first section; and

a lower section extending from the intermediate section and having an inner surface diameter smaller than the inner surface diameter of the first section, wherein the channel is bounded by the three sections.]

[31. An assembly as recited in claim 30 wherein threads are formed on a lower portion of the outer surface of the fitting first section and wherein threads are formed on the inner surface of the flange nut upper section, and wherein the flange nut upper section is threaded to the lower portion of the fitting first section.]

[32. An assembly as recited in claim 31 further comprising a load key bolt corresponding to each load key, wherein each load key bolt radially penetrates a corresponding opening formed on the second section of the flange nut and threadedly engages a load key.]

[33. An assembly as recited in claim 32 further comprising a retainer coupled to each load key bolt, wherein each retainer allows for rotational movement of its corresponding bolt, and wherein each retainer is mounted on an outer surface of the flange nut.]

[34. An assembly as recited in claim 31 wherein each load key is arc shaped.]

[35. An assembly as recited in claim 34 wherein the groove formed on the outer surface of the casing head is an annular groove and wherein the load keys abut each other forming a ring when moved to a position in the annular groove.]

[36. An assembly as recited in claim 31 wherein the casing head second portion has threads formed on its inner surface for threading onto threads formed on the outer surface of the casing.]

[37. An assembly as recited in claim 29 further comprising a coupling for coupling the casing head to the casing, the coupling having first and second ends and inner threads, wherein the first end of the coupling is threaded to the outer surface of the casing and wherein the casing head has outer threads for threading on to the inner threads at the second end of the coupling.]

[38. An assembly as recited in claim 29 further comprising: a wear bushing lining at least a portion of the inner surface of the casing head and at least part of the inner surface of the quick connector fitting immediately above the casing head; and

and a lock screw radially screwed through the fitting and engaging the bushing for retaining the bushing in place.]

[39. An assembly as recited in claim 29 further comprising: an annular groove formed on the inner surface of the fitting; and

a seal fitted within the annular groove for sealing against an outer surface of the casing head.]

40. A method for removably connecting a fitting to a well casing allowing for the attachment of well related equipment, the method comprising the steps of:

releasably coupling a casing head having an external groove to the casing;

14

mounting a fitting over the casing head, the fitting comprising a portion surrounding the casing head and providing an interface for mounting well related equipment; coupling a flange nut on the fitting, the flange nut comprising a plurality of moveable load keys; and moving a plurality of load bolts through the flange nut for moving the load keys into the groove for locking the fitting onto the casing head.

41. A method as recited in claim 40 wherein [the] coupling a flange nut step comprises [the step of] threading the flange nut on a lower outer surface portion of the fitting.

42. A method as recited in claim 41 further comprising [the step of] further threading the flange nut onto the fitting after [the step of] moving for causing the fitting to seat tightly against the casing head.

43. A method as recited in claim 40 wherein the keys are arc shaped.

[44. A quick connect assembly for providing an interface for the attachment of equipment to a well casing, the assembly comprising:

a tubular male receiver comprising,
a first end portion for coupling to the well casing,
a second end portion forming a mouth, and
an annular lip formed around the second end portion, the annular lip having a lower surface sloping upward in a radially outward direction;

a fitting mounted over the second end portion of the male receiver, the fitting comprising,
a first section having a cylindrical inner surface having a diameter at least as large as the outer surface diameter of the annular lip,

second section over the first section,
a surface at an upper end of the second section for interfacing with the equipment to be mounted, and
at least an opening formed radially through the first section; and

a fastener fitted through the opening and having a frustoconical tip portion engaging the lower sloping surface of the annular lip for pulling the fitting against male receiver and for fastening the fitting to the male receiver.]

[45. An assembly as recited in claim 44 further comprising a seal between the annular lip and the first section.]

[46. A quick connect assembly for providing an interface for the attachment of equipment to a well casing, the assembly comprising:

a tubular male receiver comprising,
a first end portion for coupling to the well casing,
a second end portion forming a mouth and having an outer surface, and
a groove formed on the second end portion outer surfaces the groove having an upper surface sloping upward in a radially outward direction;

a fitting mounted over the second end portion of the male receiver, the fitting comprising,
a first section having a cylindrical inner surface having a diameter at least as large as the outer surface diameter of the male receiver second end portion,

second section over the first section,
a surface at an upper end of the second section for interfacing with the equipment to be mounted, and
at least an opening formed radially through the first section; and

a fastener fitted through the opening and having a frustoconical tip portion for engaging to the groove sloping

15

upper surface for pulling the fitting against the male receiver and for fastening the fitting to the male receiver.]

[47. An assembly as recited in claim 46 further comprising a seal between the second end portion and the first section.] 5

[48. An assembly as recited in claim 46 wherein the groove circumferentially spans the entire second end portion outer surface.]

[49. A quick connect assembly for providing an interface for the attachment of equipment to a well casing, the assembly comprising: 10

- a tubular male receiver comprising,
 - a first end for coupling to the well casing,
 - a second end forming a mouth, and
 - a first annular lip formed around the second end, the annular lip having a lower surface, 15
 - a second annular lip formed around the outer surface of the male receiver below and spaced apart from the first lip forming a groove there between,
 - at least one depression on the second annular lip for accepting a torque tool for torquing the male receiver to the coupling; and 20
 - a fitting mounted over the second end of the male receiver, the fitting comprising,
 - a first section having a cylindrical inner surface having a diameter at least as large as the outer surface diameter of the first annular lip, 25
 - a second section over the first section,
 - a surface at an upper end of the second section for interfacing with the equipment to be attached, 30
 - at least a threaded opening formed radially through the first section, and
 - a fastener threaded through the opening and engaging the lower surface of the first lip for fastening the fitting to the male receiver.] 35

[50. A quick connect assembly for providing an interface for the attachment of equipment to a well casing, the assembly comprising:

- a tubular male receiver comprising,
 - a first end for coupling to the well casing, 40
 - a second end forming a mouth, and
 - a first annular lip formed around the second end, the annular lip having an upper surface sloping downward in a radially outward direction and a lower surface; and 45
 - a fitting mounted over the second end of the male receiver, the fitting comprising,
 - a first section having a cylindrical inner surface having a diameter at least as large as the outer surface diameter of the annular lip, 50
 - a second section over the first section,
 - a surface at an upper end of the second section for interfacing with the equipment to be attached,
 - an intermediate section between the first and second sections, wherein the intermediate section has a frusto-conical inner surface complementary to the lip upper surface; 55
 - at least a threaded opening formed radially through the first section, and
 - a fastener threaded through the opening and engaging the lower surface of the first lip for fastening the fitting to the male receiver.] 60

[51. A quick connect assembly for providing an interface for the attachment of equipment to a well casing, the assembly comprising:

- an annular fitting having an inner and an outer surface for fitting over a well casing, comprising,

16

a surface at a top end of the fitting for providing an interface for the equipment to be mounted, an annular surface extending from the inner surface for engaging the casing mouth,

an inner annular groove formed on the inner surface of the fitting below the fitting annular surface,

an injection fitting extending from the outer surface of the fitting and providing access to the inner annular groove for injecting the groove with a sealing material, and

an annular groove formed on the outer surface near a lower end of the fitting, the groove having an upper surface, a lower surface and a side surface therebetween;

an annular retainer slip comprising,

- an upper annular lip extending radially inward for fitting within the fitting outer surface annular groove, and
- a lower annular lip extending radially inward and having an annular edge comprising a surface for engaging an outer surface of the casing; and
- a clamp surrounding the retainer slip for compressing the retainer slip toward the casing.]

52. A quick connect assembly for providing an interface surface for the attachment of equipment to a well casing, the assembly comprising:

a casing head comprising an outer surface and a groove formed on the outer surface;

a fitting mounted over the casing head comprising an inner surface surrounding at least a portion of the casing head outer surface and an interface surface for interfacing with the equipment to be mounted wherein said portion of the casing head outer surface is within and concentric with said fitting inner surface;

an annular nut releasably coupled to the fitting and having a channel formed on its inner surface;

a plurality of arc shaped members moveable from a first position at least partly within said channel to a second position wherein at least a portion of each arc shaped member is received in the groove, and wherein each arc shaped member is sandwiched between the annular nut and the fitting; and

a rotating member coupled to the annular nut wherein rotation of the rotating member in a first direction causes one of said plurality of arc shaped members to translate to the second position.

53. A quick connect assembly as recited in claim 52 wherein the rotating member is a bolt.

54. A quick connect assembly as recited in claim 52 wherein the annular nut surrounds the fitting.

55. A quick connect assembly as recited in claim 54 wherein the annular nut is threaded to the fitting.

56. A quick connect assembly as recited in claim 52 further comprising a seal between the inner surface of the fitting and the outer surface of the casing head.

57. A quick connect assembly as recited in claim 56 wherein the seal is fitted in a groove formed on the inner surface of the fitting.

58. A quick connect assembly as recited in claim 56 further comprising a rotating member coupled to the fitting, wherein rotation of the rotating member in a first direction causes one of said plurality of arc shaped members to move the second position.

59. A quick connect assembly as recited in claim 58 wherein the rotating member is a bolt.

60. A quick connect assembly as recited in claim 59 wherein the annular nut surrounds the fitting.

61. A quick connect assembly as recited in claim 60 wherein the annular nut is threaded to the fitting.

62. A quick connect assembly as recited in claim 52 wherein each arc shaped member is mounted on the annular nut.

63. A quick connect assembly for tubular members comprising:

a first tubular member comprising an outer surface and a groove formed on the outer surface;

a second tubular member mounted over the first tubular member and comprising an inner surface surrounding at least a portion of the first tubular member outer surface, wherein said at least a portion of the first tubular member outer surface is within and concentric with said second tubular member inner surface;

an annular member coupled to the second tubular member and surrounding the first tubular member; and

a plurality of moveable members moveable from a first position to a second position wherein at least a portion of each moveable member is received in the groove, and wherein each moveable member is mounted on the annular member; and

an actuating member coupled to the annular member, wherein the actuating member translates in a first direction moving one of said movable members to the second position and in a second direction opposite the first direction.

64. A quick connect assembly as recited in claim 63 wherein upon rotation of the actuating member in a first rotational direction, the actuating member translates in the first direction, and wherein rotation of the actuating member in a second rotational direction opposite the first rotational direction causes the actuating member to translate in the second direction.

65. A quick connect assembly as recited in claim 64 wherein upon rotation, the actuating member translates transversely to a longitudinal axis of the second tubular member.

66. A quick connect assembly as recited in claim 65 wherein the actuating member is a bolt.

67. A quick connect assembly as recited in claim 63 wherein the annular member is an annular nut coupled to the second tubular member, wherein the actuating member is mounted on the annular nut.

68. A quick connect assembly as recited in claim 63 wherein each moveable member is sandwiched between the annular nut and the second tubular member.

69. A quick connect assembly as recited in claim 68 wherein the annular nut is threaded to the second tubular member.

70. A method for removably connecting a first fitting to a well fitting having a mouth and external threads, allowing for the attachment of well related equipment, the method comprising:

threading a bushing on the external threads of the well fitting to a location about $\frac{1}{8}$ inch to $\frac{3}{8}$ inch below the mouth of the well fitting, the bushing having an outer depression;

mounting the first fitting over the bushing and well fitting, the first fitting providing an interface for mounting well related equipment; and

fastening the first fitting against the depression on the bushing by threading a fastener through the fitting and into the depression.

71. A method for removably connecting a first fitting to a well fitting having a mouth and external threads, allowing for the attachment of well related equipment, the method comprising:

threading a bushing on the external threads of the well fitting, the bushing having an outer depression spanning an entire circumference of said bushing;

mounting the first fitting over the bushing and well fitting, the first fitting providing an interface for mounting well related equipment; and

fastening the first fitting against the depression on the bushing by threading a fastener through the fitting and into the depression.

72. A method for removably connecting a first fitting to a well fitting allowing for the attachment of well related equipment, the method comprising:

coupling a well fitting having an external groove to the casing;

mounting the first fitting over the well fitting, the first fitting providing an interface surface for mounting well related equipment;

releasably coupling a flange nut on the first fitting, wherein a plurality of moveable load keys are connected to the flange nut;

translating the load keys into the groove for locking the first fitting onto the well fitting; and

further threading the flange nut onto the first fitting causing the first fitting to seat tightly against the well fitting.

73. A quick connect assembly for tubular members comprising:

a first tubular member comprising an outer surface and a groove formed on the outer surface;

a second tubular member mounted over the first tubular member and comprising an inner surface surrounding at least a portion of the first tubular member outer surface, wherein said at least a portion of the first tubular member outer surface is within and concentric with said second tubular member inner surface;

an annular member coupled to the second tubular member and surrounding the second tubular member; and

a moveable member translating from a first position to a second position, wherein at least a portion of the moveable member is received in the groove, and wherein the moveable member is connected to the annular member and spans an arc less than 180° .

74. A quick connect assembly as recited in claim 73 wherein the moveable member is sandwiched between the annular member and the second tubular member.

75. A method for removably connecting a fitting to a well casing having a mouth and external threads allowing for the attachment of well related equipment, the method comprising the steps of:

threading a bushing on the external threads of the casing, the bushing having a generally cylindrical outer surface and an outer depression formed on said generally cylindrical outer surface;

mounting a fitting over the bushing and well casing, the fitting providing an interface for mounting well related equipment; and

threading a fastener through the fitting to engage the depression on the bushing fastening the fitting against the depression on the bushing.

76. A method as recited in claim 75 wherein the depression on the bushing is an annular groove, the method further comprising orienting the fitting to a desired position over the bushing and casing prior to fastening.

77. A method as recited in claim 76 further comprising threading a nut on a fastener from an end opposite an end engaging the groove for contacting the fitting and preventing the loosening of the fastener from the fitting.

78. A method as recited in claim 75 wherein fastening the fitting comprises pulling the fitting toward the casing for seating on the mouth of the casing.

79. A method as recited in claim 74 wherein fastening the fitting further comprises forming a seal between the fitting and the mouth of the casing.

80. A method as recited in claim 75 wherein threading a bushing comprises threading the bushing to a location about $\frac{1}{8}$ inch to $\frac{3}{8}$ inch below the mouth of the casing.

81. A method as recited in claim 75 wherein the depressions spans an entire circumference of said bushing.

82. A quick connect assembly for providing an interface surface for the attachment of equipment to a well casing, the assembly comprising:

casing head comprising,

a first portion forming a mouth and having an outer surface having a diameter;

a second portion for coupling to the well casing, and a groove formed on the outer surface of the casing head;

a fitting mounted over the first portion of the casing head and surrounding at least a portion of the first portion outer surface, wherein said at least a portion of the casing head outer surface is within and concentric with said fitting, the fitting comprising,

a first section mounted over the first portion of the casing head, the fitting first section comprising an annular edge, and

a second section extending over the first section and having a surface for interfacing with the equipment to be mounted;

an annular flange nut releasably coupled to the fitting and having a channel formed on its inner surface;

a plurality of load keys located in the channel and movable to a position within the groove on the outer surface of the casing head for engaging a surface of the groove and the first section annular edge; and

a load key bolt for each load key for moving said load keys for engaging the surface of the groove.

83. An assembly as recited in claim 80 wherein the annular flange nut comprises:

an upper annular section coupled to the fitting;

an intermediate section extending from the upper section and having an inner surface diameter larger than the first section; and

a lower section below the upper annular section and extending from the intermediate section and having an inner surface diameter smaller than the inner surface diameter of the first section, wherein the channel is bounded by the three sections.

84. An assembly as recited in claim 83 wherein threads are formed on a lower portion of the outer surface of the fitting first section and wherein threads are formed on the inner surface of the annular flange nut upper section, and wherein the annular flange nut upper section is threaded to the lower portion of the fitting first section.

85. An assembly as recited in claim 84 wherein each load key bolt radially penetrates a corresponding opening formed on the second section of the annular flange nut and threadedly engages a load key.

86. An assembly as recited in claim 85 further comprising a retainer coupled to each load key bolt, wherein each retainer allows for rotational movement of its corresponding

bolt, and wherein each retainer is mounted on an outer surface of the annular flange nut.

87. An assembly as recited in claim 84 wherein each load key is arc shaped.

88. An assembly as recited in claim 87 wherein the groove formed on the outer surface of the casing head is an annular groove and wherein the load keys abut each other forming a ring when moved to a position in the annular groove.

89. An assembly as recited in claim 84 wherein the casing head second portion has threads formed on its inner surface for threading onto threads formed on the outer surface of the casing.

90. An assembly as recited in claim 82 further comprising a coupling for coupling the casing head to the casing, the coupling having first and second ends and inner threads, wherein the first end of the coupling is threaded to the outer surface of the casing and wherein the casing head has outer threads for threading onto the inner threads at the second end of the coupling.

91. An assembly as recited in claim 82 further comprising: a wear bushing lining at least a portion of the inner surface of the casing head and at least part of the inner surface of the quick connector fitting immediately above the casing head; and

a lock screw radially screwed through the fitting and engaging the bushing for retaining the bushing in place.

92. An assembly as recited in claim 82 further comprising: an annular groove formed on the inner surface of the fitting; and

a seal fitted within the annular groove for sealing against an outer surface of the casing head.

93. A quick connect assembly for providing an interface for the attachment of equipment to a well casing, the assembly comprising:

a tubular male receiver comprising,

a second end portion for coupling to the well casing,

a first end portion opposite the first end portion forming a mouth, and

an annular lip formed around the first end portion, the annular lip having a surface sloping upward in a radially outward direction;

a fitting mounted over the first end portion of the male receiver, the fitting comprising,

a first section having a cylindrical inner surface having a diameter at least as large as the outer surface diameter of the annular lip,

a second section over the first section

a flange having a surface at an end of the second section for interfacing with the equipment to be mounted, and for supporting said equipment said surface extending above the male receiver, and

at least an opening formed radially through the first section; and

a fastener fitted through the opening and having a frusto-conical tip portion engaging the sloping surface of the annular lip for pulling the fitting against the male receiver and for fastening the fitting to the male receiver, wherein the flange comprises at least an axial opening for receiving a fastener for fastening said equipment.

94. A quick connect assembly for providing an interface for the attachment and support of equipment to a well casing, the assembly comprising:

a tubular male receiver comprising,

a second end portion for coupling to the well casing,

a first end portion over the second end portion, said first end portion forming a mouth and having an outer surface, and

21

a groove formed on the first end portion outer surface the groove having a surface sloping upward in a radially outward direction;

a fitting mounted over the first end portion of the male receiver, the fitting comprising,

5 a first section having a cylindrical inner surface having a diameter at least as large as the outer surface diameter of the male receiver first end portion,

a second section over the first section and extending above the male receiver,

10 a flange having a surface at an end of the second section for interfacing with the equipment to be mounted and for supporting said equipment, and at least an opening formed radially through the first section; and

15 a fastener fitted through the opening and having a frusto-conical tip portion for engaging the groove sloping surface for pulling the fitting against the male receiver and for fastening the fitting to the male receiver, wherein the flange comprises at least an axial opening for receiving a fastener for fastening said equipment.

95. A quick connect assembly:

a tubular member comprising,

a second end for coupling to a well casing,

a first end over the second end forming a mouth, and

a first annular lip formed around the first end, the first annular lip having a lower surface below an upper surface; and

30 a fitting mounted over the first end of the tubular member, the fitting comprising,

a first section having a cylindrical inner surface having a diameter at least as large as the outer surface diameter of the second annular lip,

a second section over the first section said second section extending above the tubular member and comprising a flange extending therefrom, and

35 at least an opening formed radially through the first section; and

a fastener threaded to the opening and engaging the lower surface of the first lip for fastening the fitting to the tubular member, wherein the flange comprises at least an axial opening for receiving a fastener.

96. A quick connect assembly:

a well tubular member comprising,

a first end forming a mouth, and

a first annular lip formed around the end, the first annular lip having a lower surface below an upper surface; and

50 a fitting mounted over the end of the tubular member, the fitting comprising,

a first section having a cylindrical inner surface having a diameter at least as large as an outer surface diameter of the first annular lip,

55 second section over the first section said second section extending above the well tubular member and comprising flange extending therefrom,

22

at least an opening formed radially through the first section, and

a fastener threaded to the opening and engaging the lower surface of the first annular lip for fastening the fitting to the tubular member, wherein the flange comprises at least an axial opening for receiving a fastener.

97. An assembly as recited in claim 52 wherein said interface surface is defined on a flange extending from said fitting.

98. An assembly as recited in claim 97 wherein the flange comprises at least an axial opening for receiving a fastener for fastening said equipment.

99. An assembly as recited in claim 63 wherein a flange extends from said second tubular member and comprises at least an axial opening.

100. An assembly as recited in claim 73 wherein a flange extends from said second tubular member and comprises at least an axial opening.

101. An assembly as recited in claim 80 wherein said interface surface is defined on a flange extending from said fitting.

102. An assembly as recited in claim 101 wherein the flange comprises at least an axial opening for receiving a fastener for fastening said equipment.

25 103. An assembly as recited in claim 93 further comprising a seal between the annular lip and the first section.

104. An assembly as recited in claim 94 further comprising a seal between the second end portion and the first section.

105. An assembly as recited in claim 94 wherein the groove circumferentially spans the entire second end portion outer surface.

106. An assembly as recited in claim 95 further comprising a seal between the annular lip and the first section.

35 107. An assembly as recited in claim 95 further comprising a second annular lip formed around the outer surface of the tubular member below and spaced apart from the first annular lip forming a groove therebetween.

108. An assembly as recited in claim 95 further comprising at least one depression on the first annular lip for accepting a torque tool for torquing the tubular member to a coupling.

40 109. An assembly as recited in claim 95 wherein the fitting comprises four radial openings through the second section, said openings being equidistantly located around the second section, and wherein the assembly comprises four fasteners penetrating the openings and engaging the lower surface of the first annular lip.

45 110. An assembly as recited in claim 96 wherein the fitting further comprises a frusto-conical section between the first and second sections, wherein the frusto-conical section has a frusto-conical inner surface and wherein the first annular lip upper surface slopes downward in a radially outward direction, wherein the frusto-conical inner surface is complementary to the lip upper surface.

* * * * *

UNITED STATES PATENT AND TRADEMARK OFFICE
CERTIFICATE OF CORRECTION

PATENT NO. : RE43,773 E
APPLICATION NO. : 11/581229
DATED : October 30, 2012
INVENTOR(S) : Rex E. Duhn

Page 1 of 1

It is certified that error appears in the above-identified patent and that said Letters Patent is hereby corrected as shown below:

In the Claims

Column 16, Claim 56, line 52	Delete "are" Insert -- as --
Column 19, Claim 79, line 8	Delete "74" Insert -- 78 --
Column 19, Claim 83, line 43	Delete "80" Insert -- 82 --
Column 22, Claim 101, line 19	Delete "80" Insert -- 82 --

Signed and Sealed this
Sixteenth Day of September, 2014



Michelle K. Lee
Deputy Director of the United States Patent and Trademark Office