

US00RE43635E

(19) **United States**  
(12) **Reissued Patent**  
**Dunn et al.**

(10) **Patent Number:** **US RE43,635 E**  
(45) **Date of Reissued Patent:** **Sep. 11, 2012**

(54) **BOTTLE RACK**

(76) Inventors: **Steven B. Dunn**, Beverly Hills, CA (US); **Tor H. Petterson**, Rancho Palos Verdes, CA (US); **Grace C. Petterson**, legal representative, San Pedro, CA (US)

(21) Appl. No.: **09/902,904**  
(22) Filed: **Jul. 11, 2001**

**Related U.S. Patent Documents**

Reissue of:

(64) Patent No.: **6,038,784**  
Issued: **Mar. 21, 2000**  
Appl. No.: **09/113,868**  
Filed: **Jul. 10, 1998**

(51) **Int. Cl.**  
**F26B 25/18** (2006.01)  
(52) **U.S. Cl.** ..... **34/104; 34/107; 211/41.6; 211/74; 248/102**  
(58) **Field of Classification Search** ..... **34/437, 34/440, 104, 105, 106, 107; 211/41.3, 41.5, 211/41.6, 74, 71.01, 181.1, 70.7, 85.18, 85.25, 211/41.4; 248/102**

See application file for complete search history.

(56) **References Cited**

**U.S. PATENT DOCUMENTS**

499,881	A	6/1893	Goldstein	
1,697,879	A *	1/1929	Olson	34/229
1,942,345	A *	1/1934	Ristow	493/109
2,039,927	A	5/1936	Poglein	
2,128,192	A *	8/1938	Risser	198/403
2,197,178	A *	4/1940	Gates	34/569
2,258,676	A *	10/1941	De Lano	15/210.1
2,273,761	A *	2/1942	Newton et al.	366/217
2,295,736	A	9/1942	Jernson	
2,328,129	A *	8/1943	Earle	34/90
2,351,309	A *	6/1944	White	106/131.1

(Continued)

**FOREIGN PATENT DOCUMENTS**

CH 685919 A5 11/1995  
(Continued)

**OTHER PUBLICATIONS**

Product Literature of Safety 1st entitled "Bottle & Nipple Drying Rack," 1996.

(Continued)

*Primary Examiner* — Stephen M. Gravini

(74) *Attorney, Agent, or Firm* — Robert Z. Evora, Esq.; John L. Knoble, Esq.

(57) **ABSTRACT**

An apparatus for drying and storing an article, such as a baby bottle, after washing and rinsing includes a tray having a bottom face that is adapted to be supported by an underlying surface such as a counter-top, and an upper face. A plurality of pegs extend out from the upper face, and each peg is sized and arranged so as to be able to support an article, such as a baby bottle, after washing and rinsing. Each peg is mounted to the tray in such a manner as to be movable between a first storage position, wherein the entire peg is positioned relatively close to the upper face for storage and packaging, and a second, operative position. This permits the apparatus to be conveniently folded for packaging and storage purposes. Another aspect of the apparatus involves disk holding structure, connected to the upper face of the tray, for holding baby bottle disks in a location that is isolated from areas of the tray in which liquid may collect. This permits baby bottle disks to be dried and stored in a safe manner at a location that is convenient to a location at which baby bottles are being dried.

**5 Claims, 3 Drawing Sheets**

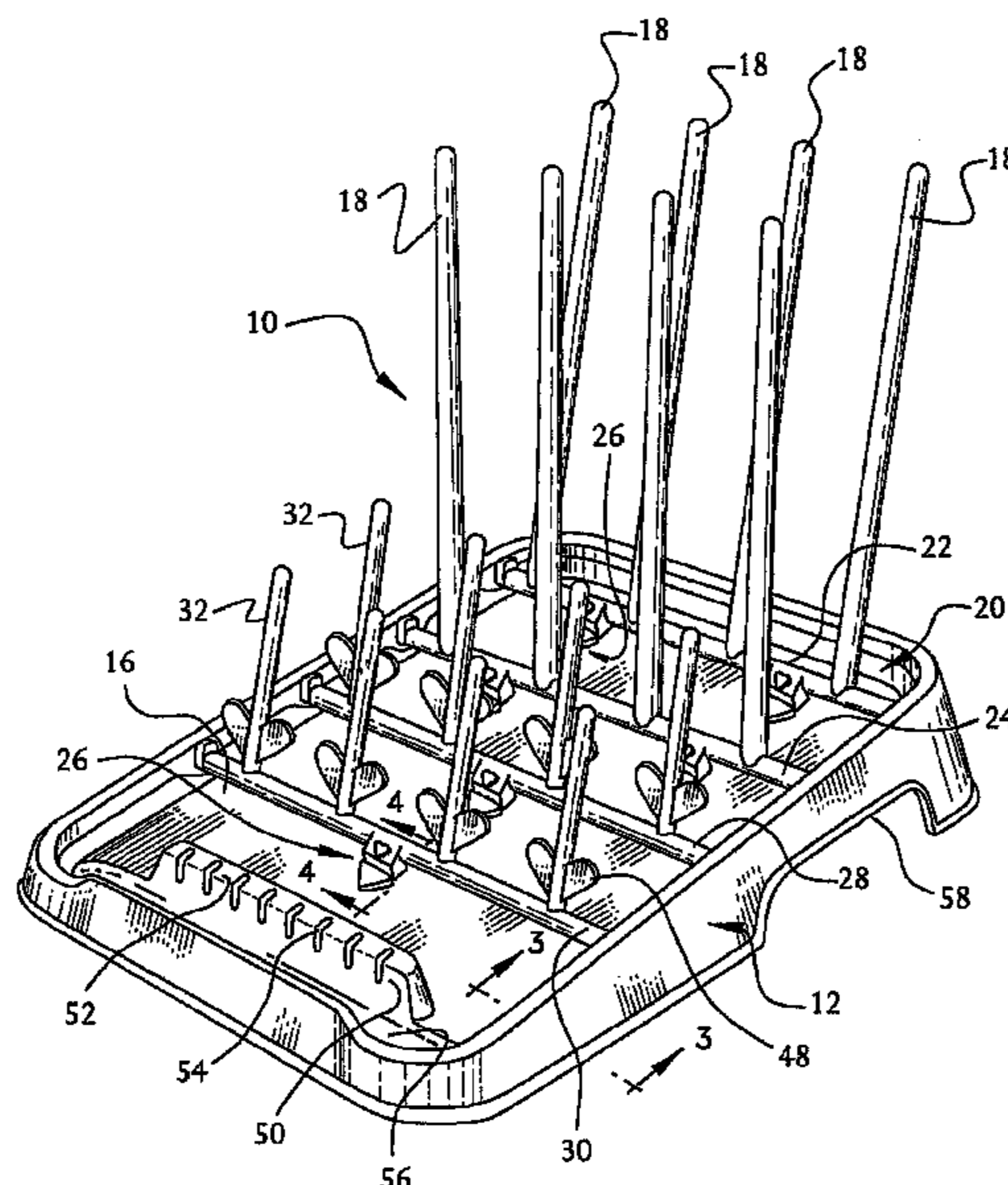

# US RE43,635 E

Page 2

## U.S. PATENT DOCUMENTS

2,411,365 A \* 11/1946 Card ..... 34/82  
 2,419,040 A 4/1947 Stepanian  
 2,441,417 A 5/1948 Hopkins  
 2,455,848 A 12/1948 Young  
 2,472,028 A \* 5/1949 Son ..... 422/310  
 2,516,088 A 7/1950 Einhorn  
 2,539,613 A \* 1/1951 Earle ..... 62/258  
 2,551,140 A \* 5/1951 Ladewig ..... 134/74  
 2,595,242 A \* 5/1952 Goodin ..... 34/69  
 2,708,350 A \* 5/1955 Earle ..... 62/277  
 2,724,329 A \* 11/1955 Lucas ..... 101/126  
 2,879,900 A 3/1959 Fox  
 2,884,708 A \* 5/1959 Levitt ..... 34/553  
 2,892,733 A \* 6/1959 Gardner et al. .... 427/223  
 2,936,898 A 5/1960 Miguez  
 3,026,628 A \* 3/1962 Berger, Sr. et al. .... 34/231  
 3,072,452 A \* 1/1963 Sleeper ..... 312/228  
 3,150,996 A \* 9/1964 Johnson ..... 118/102  
 3,193,160 A \* 7/1965 Veit et al. .... 222/440  
 3,339,595 A \* 9/1967 Pechmann ..... 141/44  
 3,367,044 A \* 2/1968 Fitch ..... 34/197  
 3,464,566 A 9/1969 Gilson  
 3,587,865 A 6/1971 Phillips  
 3,730,354 A 5/1973 Bronstein  
 3,886,683 A \* 6/1975 Hudgin et al. .... 47/9  
 3,984,940 A \* 10/1976 Reich et al. .... 47/9  
 3,989,575 A \* 11/1976 Davies et al. .... 156/355  
 4,193,588 A 3/1980 Doneaux  
 4,202,948 A \* 5/1980 Peascoe ..... 525/70  
 4,221,299 A 9/1980 Taylor  
 4,238,035 A \* 12/1980 Kassanchuk ..... 211/74  
 4,457,877 A \* 7/1984 Love et al. .... 261/64.3  
 4,485,929 A 12/1984 Betts, Sr.  
 4,498,594 A 2/1985 Elder  
 4,512,489 A 4/1985 Green et al.  
 4,578,881 A \* 4/1986 Karlsson ..... 34/619  
 4,708,153 A 11/1987 Hambleton et al.  
 4,732,291 A 3/1988 McConnell  
 4,748,993 A \* 6/1988 Llewellyn ..... 134/166 R  
 4,830,200 A 5/1989 Zambano et al.  
 4,836,392 A 6/1989 Constantino  
 4,928,841 A 5/1990 Arthurs  
 5,211,191 A \* 5/1993 Brown ..... 134/201  
 5,242,255 A 9/1993 Gleffe et al.  
 D342,191 S 12/1993 Cronk  
 5,284,170 A \* 2/1994 Larsen ..... 134/44  
 5,287,636 A 2/1994 Lafleur et al.  
 5,336,330 A \* 8/1994 Shumway et al. .... 134/8  
 5,406,717 A 4/1995 Dofka  
 5,469,635 A 11/1995 Lamontagne et al.  
 5,492,237 A 2/1996 Chang  
 5,494,086 A \* 2/1996 McBrady et al. .... 141/163  
 5,507,060 A \* 4/1996 Quimpo ..... 15/63

5,555,640 A \* 9/1996 Ou ..... 34/202  
 5,855,219 A \* 1/1999 Spencer ..... 134/167 R  
 5,857,473 A \* 1/1999 Vanover et al. .... 134/135  
 5,875,563 A 3/1999 Snow  
 5,884,778 A 3/1999 Freiheit  
 5,903,944 A \* 5/1999 Burrell ..... 15/65  
 5,913,527 A 6/1999 Hailston  
 5,967,000 A \* 10/1999 Davis ..... 81/3.4  
 5,996,600 A \* 12/1999 Ostry ..... 134/169 R  
 6,038,784 A \* 3/2000 Dunn et al. .... 34/104  
 6,073,783 A 6/2000 Allman  
 6,125,548 A \* 10/2000 Dunn et al. .... 34/104  
 6,306,219 B1 \* 10/2001 Ofosu-Asante et al. .... 134/1  
 6,363,951 B1 \* 4/2002 Wood ..... 134/102.2  
 6,743,299 B1 \* 6/2004 Barton et al. .... 134/7  
 6,814,091 B2 \* 11/2004 McConnell et al. .... 134/135  
 6,907,893 B2 \* 6/2005 Eisenberg et al. .... 134/148  
 7,165,562 B2 \* 1/2007 Myong ..... 134/56 R  
 7,478,642 B2 \* 1/2009 Koch et al. .... 134/135  
 7,549,429 B2 \* 6/2009 Nunomura et al. .... 134/184  
 7,591,273 B2 \* 9/2009 Holley, Jr. .... 134/166 R  
 7,695,572 B2 \* 4/2010 Ahn et al. .... 134/58 D  
 2003/0047198 A1 \* 3/2003 Fagnoli ..... 134/22.18  
 2003/0188769 A1 \* 10/2003 Eisenberg et al. .... 134/57 D  
 2003/0205258 A1 \* 11/2003 McConnell et al. .... 134/138  
 2004/0040586 A1 \* 3/2004 Kumar ..... 134/26  
 2004/0060577 A1 \* 4/2004 Dunn ..... 134/8  
 2004/0123885 A1 \* 7/2004 Myong ..... 134/168 R  
 2005/0178412 A1 \* 8/2005 Koch et al. .... 134/135  
 2006/0065295 A1 \* 3/2006 Dunn et al. .... 134/135  
 2006/0191562 A1 \* 8/2006 Nunomura et al. .... 134/184  
 2006/0208172 A1 \* 9/2006 Akkerman et al. .... 250/223 B  
 2006/0260651 A1 \* 11/2006 Holley, Jr. .... 134/22.1  
 2007/0102025 A1 \* 5/2007 Ahn et al. .... 134/25.2  
 2007/0212667 A1 \* 9/2007 Jung et al. .... 433/223  
 2007/0289212 A1 \* 12/2007 Shein ..... 47/65.8  
 2009/0242000 A1 \* 10/2009 Jimenez ..... 134/135  
 2009/0320889 A1 \* 12/2009 Holley, Jr. .... 134/166 R  
 2010/0043249 A1 \* 2/2010 Mulaw ..... 34/275

## FOREIGN PATENT DOCUMENTS

FR	403.288	10/1909
FR	403288	10/1909
GB	12089	0/1915
GB	160098	5/1920
GB	174267	11/1920
GB	160098	3/1921
GB	2260483 A *	4/1993

## OTHER PUBLICATIONS

Product Literature of Mommy's Helper, Inc. entitled "Drain 'N Dry Bottle Drying Rack," 1996.

\* cited by examiner

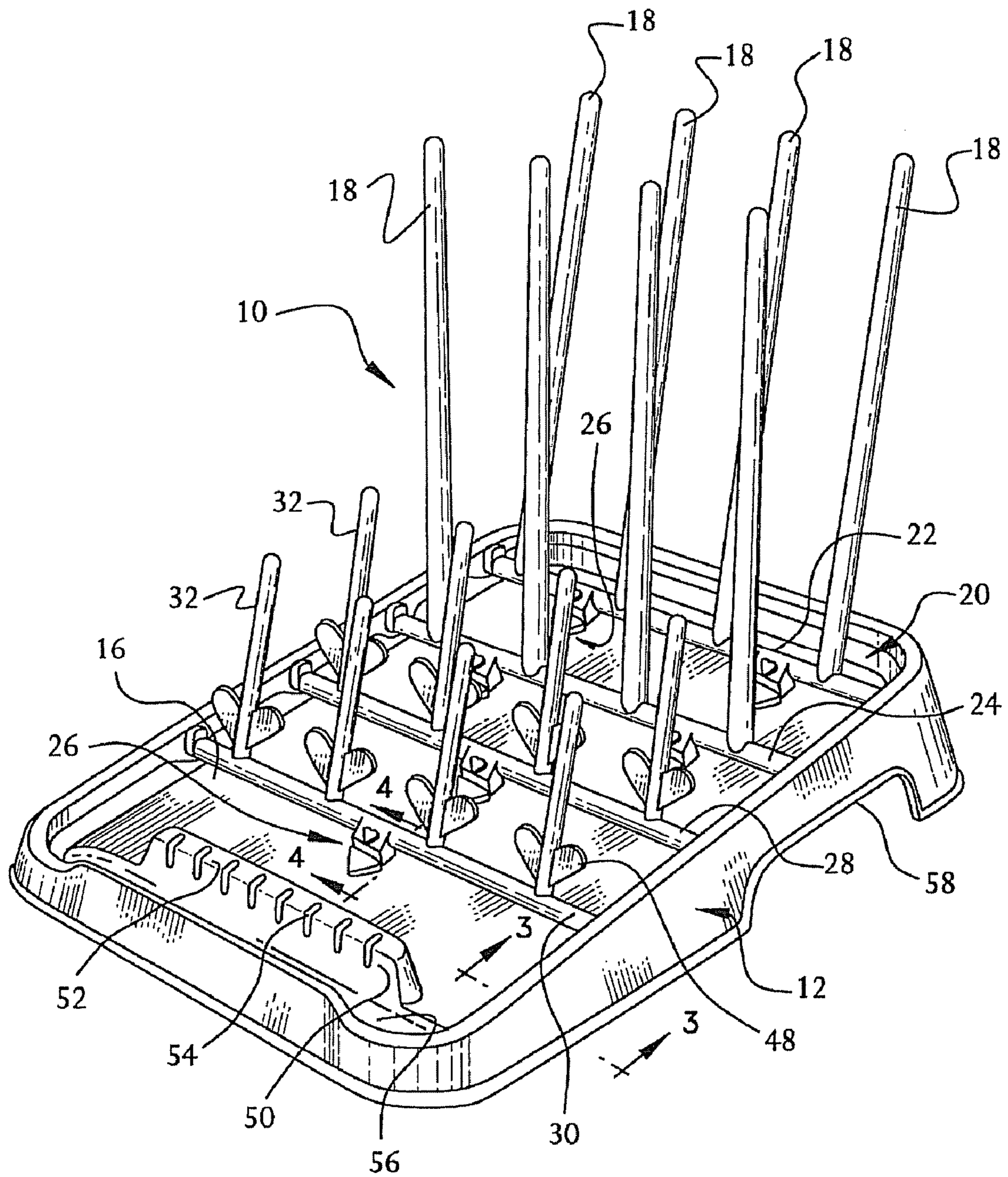

FIG. 1

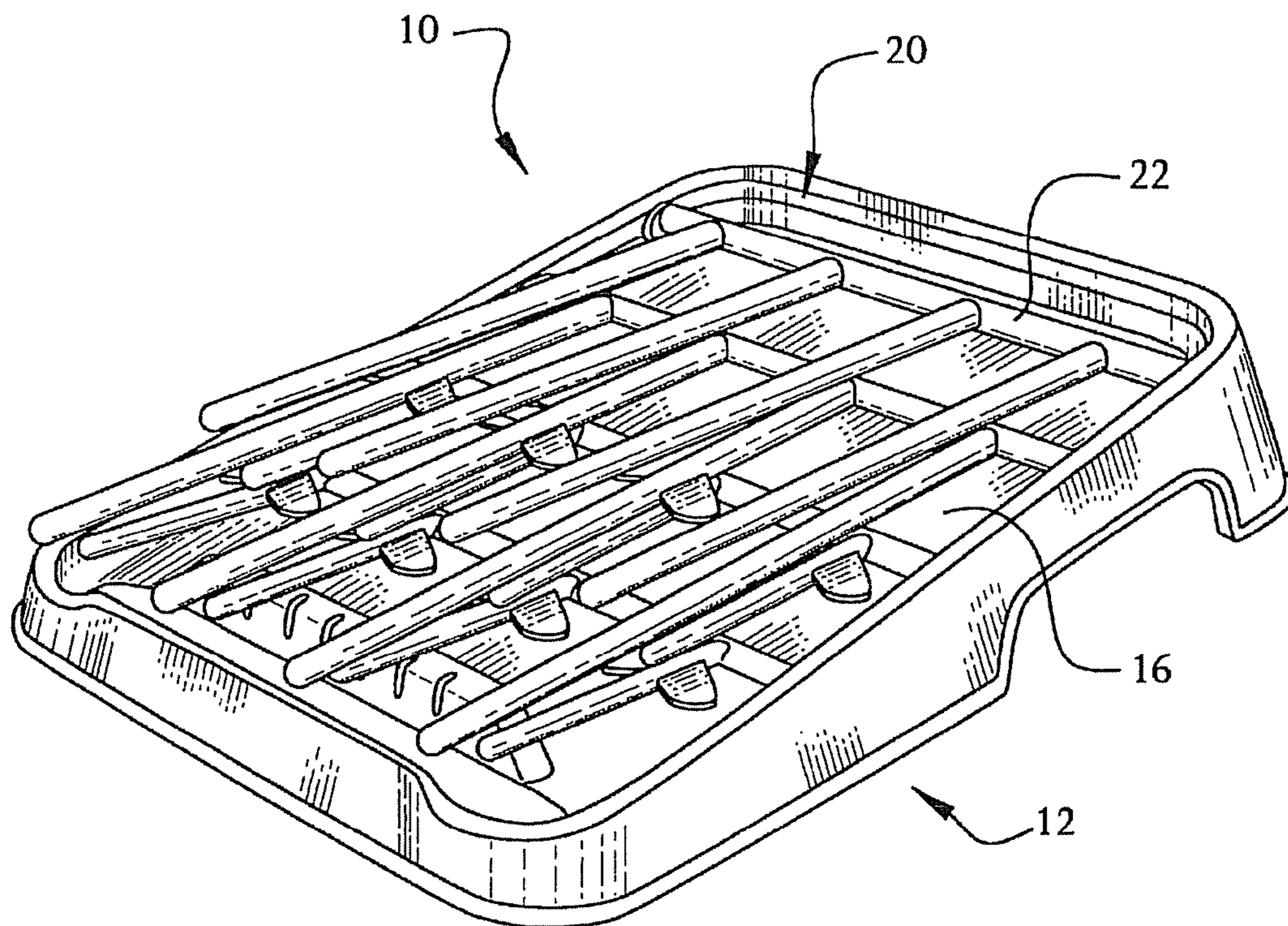

FIG. 2

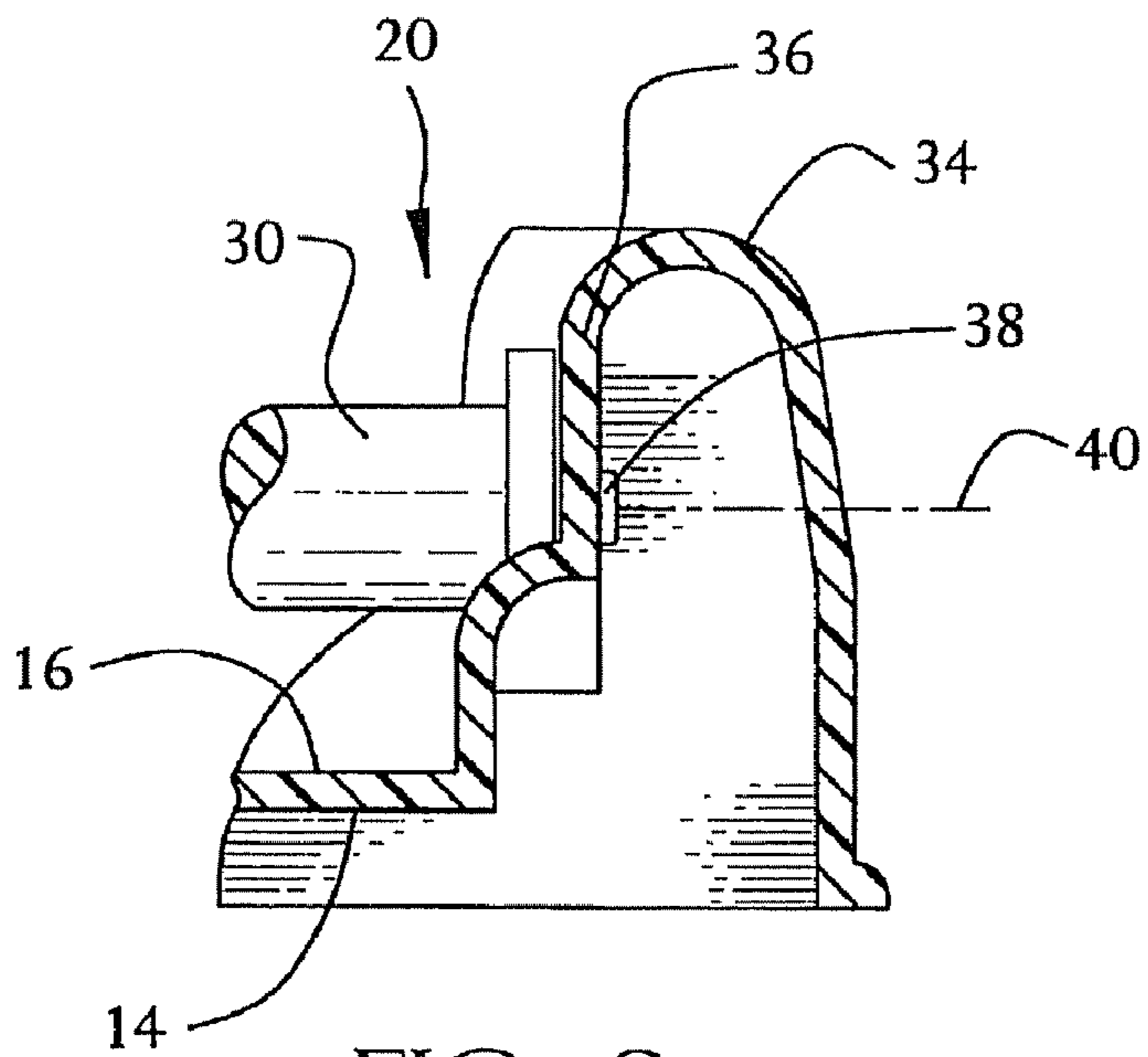

FIG. 3

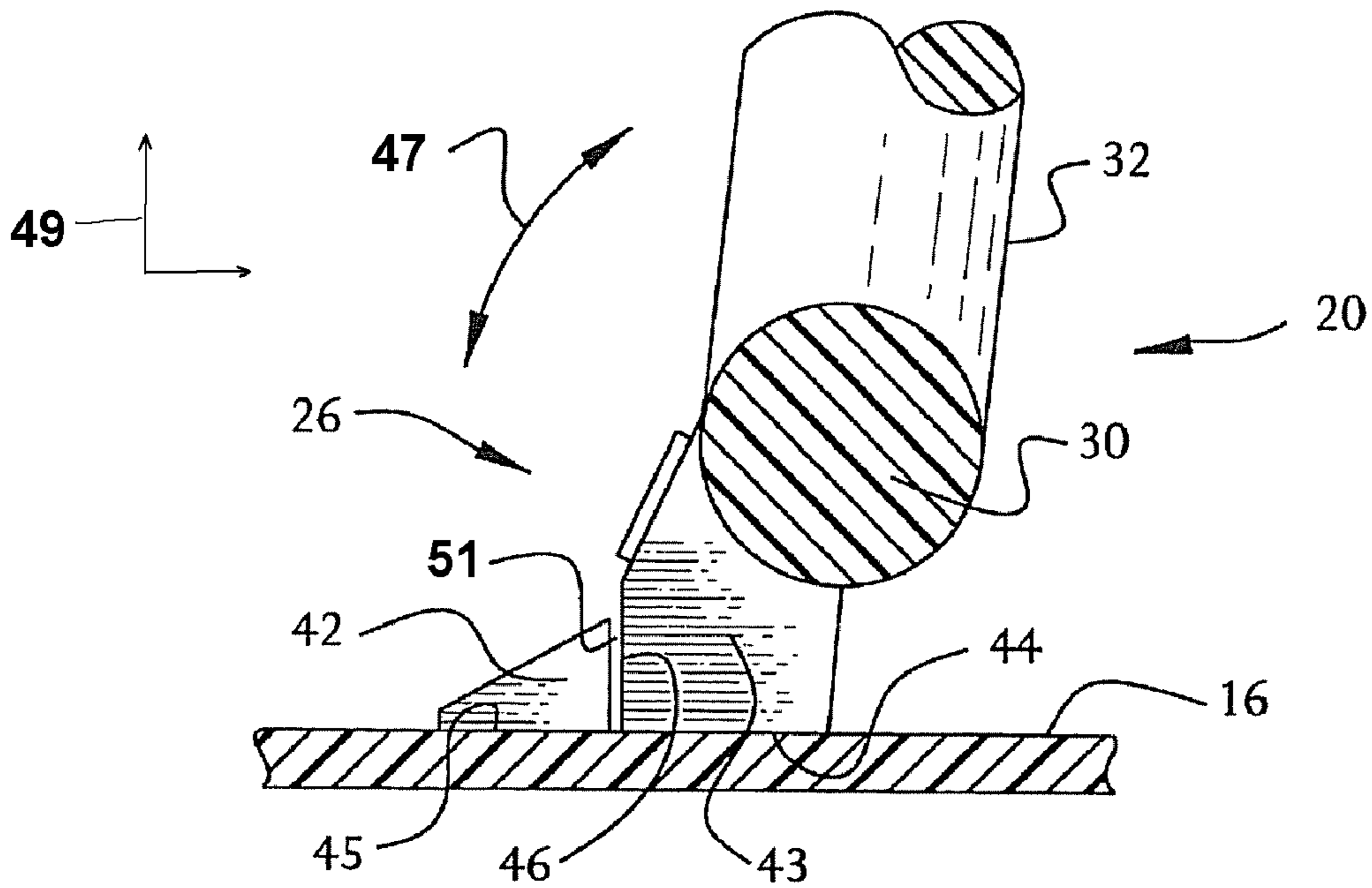

FIG. 4 (Amended)

# 1

## BOTTLE RACK

**Matter enclosed in heavy brackets [ ] appears in the original patent but forms no part of this reissue specification; matter printed in italics indicates the additions made by reissue.**

### BACKGROUND OF THE INVENTION

#### 1. Field of the Invention

This invention pertains generally to the field of infant feeding and care. More specifically, this invention relates to an improved apparatus for storing and drying infant nursing bottles, nipples and rings that is more hygienic, efficient and attractive than articles that are presently available for similar purposes, and that is more convenient to store for consumers.

#### 2. Description of the Related Technology

The importance of proper hygiene when handling and cleaning infant feeding equipment such as baby bottles and nursing nipples cannot be overstated. Ideally, bottles and nipples should be thoroughly scrubbed, then sterilized by immersion in boiling water between uses. At the very least, baby bottles and components thereof, which typically include rings, nipples, hoods and disks, must be washed with an effective detergent and dried in a location that is separated from dirty water or potential contaminants prior to storage for future use.

Drying racks for holding baby bottles, rings and nipples after washing are commercially available. For example, such products are sold by Safety 1<sup>st</sup>, Inc. as a "Bottle and Nipple Drying Rack," and by Mommy's Helper, Inc. as a "Drain 'N Dry." Both of these products are characterized by a plastic tray that has a number of socket recesses defined in a top face thereof. Plastic pegs are provided that are insertable into the socket recesses. Some of the plastic pegs are relatively long, for supporting a bottle, while others are shorter, for supporting nipples, rings and caps. Neither these products nor any other drying rack of which the inventors are aware have any way of storing the disks of a baby bottle in a sanitary location after washing.

Although products of the type described above are quite useful, the lack of disk storage forces conscientious caregivers to separate baby bottle components after washing and rinsing, which can be frustrating and can result in mix-ups between disks that have been washed and unwashed disks. In addition, the sockets that are defined in the top faces of such products can collect water and become points of nucleation for bacteria and mold growth. Furthermore, assembly and disassembly of these products can be laborious, with the need to insert multiple pegs in matching sockets and having to figure out which peg to place in each socket. These products are not convenient to store for a consumer, unless they are completely disassembled. In households that have toddlers, such racks can quickly unbeknownst to the caregiver become a plaything, and pegs can be pulled from the sockets, creating more work and frustration for the caregiver, possibly presenting a risk of injury.

A need exists for a bottle rack that requires minimal or no assembly by the user, that provides a secure and sanitary drying location for all baby bottle components, that minimizes the potential for mold and bacteria growth during use and is easy to store.

### SUMMARY OF THE INVENTION

Accordingly, it is an object of the invention to provide a bottle rack that requires minimal or no assembly by the user,

# 2

that provides a secure and sanitary drying location for all baby bottle components, that minimizes the potential for mold and bacteria growth during use and that is easy to store.

In order to achieve the above and other objects of the invention, an apparatus for drying and storing an article, such as a baby bottle includes a tray having a bottom face that is adapted to be supported by an underlying surface such as a counter-top, and an upper face; and a plurality of pegs extending outwardly from the upper face, each of the pegs being sized and arranged so as to be able to support an article, such as a baby bottle, and wherein each of the pegs are permanently mounted to the tray in such a manner as to be movable between a first storage position, wherein the entire peg is positioned relatively close to the upper face for storage and packaging of the apparatus, and a second, operative position, wherein the peg is positioned at a large angle with respect to the upper surface, so as to enable the peg to support an article such as a baby bottle, wherein the apparatus can conveniently be folded for packaging and storage purposes.

According to a second aspect of the invention, an apparatus for drying and storing an article, such as a baby bottle, includes a tray having a bottom face that is adapted to be supported by an underlying surface such as a counter-top, and an upper face; bottle support means for supporting a baby bottle; and disk holding structure, connected to the upper face of the tray, for holding baby bottle disks in a location that is isolated from areas of the tray in which liquid may collect, whereby baby bottle disks are dried and stored in a safe manner at a location that is convenient to a location at which baby bottles are being dried.

These and various other advantages and features of novelty that characterize the invention are pointed out with particularity in the claims annexed hereto and forming a part hereof. However for a better understanding of the invention, its advantages, and the objects obtained by its use, reference should be made to the drawings which form a further part hereof, and to the accompanying descriptive matter, in which there is illustrated and described a preferred embodiment of the invention.

### BRIEF DESCRIPTION OF THE DRAWINGS

FIG. 1 is a perspective view of an apparatus that is constructed according to a preferred embodiment of the invention, shown in an operative position;

FIG. 2 is a perspective view of the apparatus of FIG. 1, shown in a storage position;

FIG. 3 is a cross-sectional view taken along lines 3-3 in FIG. 1; and

FIG. 4 is a cross-sectional view taken along lines 4-4 in FIG. 1.

### DETAILED DESCRIPTION OF THE PREFERRED EMBODIMENT(S)

Referring now to the drawings, wherein like reference numerals designate corresponding structure throughout the views, and referring in particular to FIG. 1, an apparatus 10 for drying and storing an article, such as a baby bottle, after washing and rinsing includes a tray 12 having a bottom face 14 (viewable in FIG. 3) that is adapted to be supported by an underlying surface such as a countertop. Tray 12 further has an upper face 16, as may be seen in FIGS. 1-4. Tray 12 is further configured to have a number of cutout/grip areas 58 defined in sides thereof, as may best be seen in FIG. 1. The purpose of the cutout area 58 is to permit a consumer to more easily lift the apparatus 10 during use, as well as to prevent

vapor lock from occurring between the apparatus 10 and a smooth underlying surface such as a countertop. In the preferred embodiment, a cutout area 58 is positioned on each side of the apparatus 10, as well as on the rear end thereof.

As is best shown in FIGS. 1 and 2, apparatus 10 further includes a plurality of pegs 18 that extend outwardly from the upper face 16 of tray 12. Each of the pegs 18 is sized and arranged so as to be able to support an article, such as a baby bottle, after washing and rinsing. According to one important aspect of the invention, each of the pegs 18 are permanently mounted to the tray 12 in such a manner as to be moveable between a first storage position, which is illustrated in FIG. 2, wherein the entire peg 18 is positioned relatively close to the upper face 16 for storage and packaging, and a second, operative position, illustrated in FIG. 1, wherein the pegs 18 are positioned at a large angle with respect to the upper surface 16. This mounting arrangement is made possible by a permanent mounting structure 20, which is best illustrated in FIGS. 1, 3 and 4, and which will be discussed in greater detail below. The permanent mounting structure 20, as will become apparent from the description given below, is constructed in such a way that no standing water may collect at a point where a peg 18 is mounted, thereby minimizing potential for mold and bacterial growth. Permanent mounting structure 20 is further constructed so as to constrain the pegs 18 for movement about only a single axis of rotation.

As may be seen in FIG. 1, apparatus 10 further includes a number of [nipple] ring support members 32 that are constructed and arranged to support a nipple portion of a baby bottle after washing and rinsing. The [nipple] ring support members 32 are, in a manner that is substantially identical to that of the pegs 18, mounted by means of a permanent mounting structure 20 for movement between a first storage position, where the entire [nipple] ring support member 32 is positioned relatively close to the upper face 16 for storage and packaging purposes, and a second, operative position where the [nipple] ring support member 32 is positioned at a large angle with respect to the upper face 16. In other words, the mounting structure 20 for the pegs 18 is substantially identical to that of the [nipple] ring support members 32. The [nipple] ring support members 32 have stylized stops 48, which in the preferred embodiment are styled as hearts, mounted thereon for supporting rings or small bottles above the surface of tray 12. Looking again to FIG. 1, it will be seen that in the illustrated embodiment of the invention four pegs 18 are constrained for common, ganged movement in an arc about a common axis of rotation that is created by a first axle 22. Similarly, a second four pegs 18 are mounted for common movement with a second axle 24. Four [nipple] ring support members 32 are mounted for common movement about a third axle 28, while a second four [nipple] ring support members 32 are mounted for common movement with a fourth axle 30. In the preferred embodiment, the axles 22, 24, 28, 30 are substantially parallel, and therefore define arcuate paths of movement for the various pegs 18 and [nipple] ring support members 32 that are located within substantially parallel planes. This permits the various pegs 18 and [nipple] ring support members 32 to move between the first and second positions, as represented by FIGS. 2 and 1, respectively, with a minimum of interference with each other.

Looking now to FIG. 3, it will be seen that each axle 22, 24, 28, 30 includes a journal 38 that extends through a mounting hole that is defined in a sidewall 36 of an upstanding dam 34 that is formed along the periphery of the upper face 16 of the tray 12. A significant vertical distance exists between the bottom of the mounting hole and the top face 16 of the tray 12, so that water cannot escape through the mounting holes onto

an underlying surface during normal use of the apparatus 10. This mounting structure 20 is arranged in such a way so as to constrain the axle 22, 24, 28, 30 for movement about an axis of rotation 40, as is shown in FIG. 3.

Mounting structure 20, by ganging adjacent pegs 18 and adjacent [nipple] ring support members 32 together by use of a common axle, thereby imparts lateral stability to the pegs 18 and the [nipple] ring support members 32, further deterring any motion other than about the single axis of rotation 40. Accordingly, the pegs 18 are constrained to move in a predetermined plane of rotation 49.

As may best be seen in FIGS. 1 and 4, each axle 22, 24, 28, 30 includes at least one locating structure 26, the purpose of which is to lock the respective axle in a rotational position that corresponds to the second operative position shown in FIG. 1. In the illustrated embodiment, first and second axles 22, 24 include two such locating structures 26, while the third and fourth axles 28, 30 which support the shorter [nipple] ring support members 32, are equipped with but one locating structure 26. The construction of the locating structures 26, however, is uniform throughout the four axles 22, 24, 28, 30. As may be seen in FIG. 4, locating structure 26 includes a cam member 43 having a lower surface 44 that is constructed and arranged to bear against the upper face 16 of tray 12, and a forward surface 46 that is constructed and arranged to come into contact with a rear surface 44 of a cam stop 42 that projects upwardly and is unitary with the upper face 16 of tray 12. FIG. 1 and FIG. 4 both depict the locking structure 26 in the second, operative position. The path between the first and second positions is indicated in FIG. 4 by arrow 46. The [nipple] ring support member 32 is prevented from bending backwardly in the direction away from the first storage position by contact of the forward surface 46 of cam member 43 with the rear surface 44 of cam stop 42.

If it is desired to move the [nipple] ring support member 32 from the second, operative position shown in FIG. 1 to the first storage position shown in FIG. 2, a user will push the [nipple] ring support member 32 in the desired direction. Initially, this movement will be deterred by the frictional contact of the lower surface 44 and the leading edge 45 of the lower surface with the upper face 16 of tray 12. Once the leading edge 45 has cleared the upper face, however, the [nipple] ring support member 32 will easily fold down into the position that is shown in FIG. 2.

According to another important aspect of the invention, apparatus 10 further includes a disk holding system 50 for holding baby bottle disks in a location that is isolated from areas of the tray 12 in which liquid may collect. This allows baby bottle [disk] disks to be dried and stored in a safe manner at a location that is convenient to a location at which baby bottles are being dried. In the preferred embodiment, [disc] disk holding system 50 includes an upstanding boss member 52 that projects upwardly from the upper face 16 of tray 12 and has a plurality of [disc] disk receiving slots 54 defined therein. Boss member 52 and slots 54 are raised with respect to an underlying reservoir 56 that is located in the forward portion of tray 12. As an added benefit, the reservoir space also acts as a finger space area for a user to get his/her fingers beneath the [disc] disk members for lifting them out after drying.

It is to be understood, however, that even though numerous characteristics and advantages of the present invention have been set forth in the foregoing description, together with details of the structure and function of the invention, the disclosure is illustrative only, and changes may be made in detail, especially in matters of shape, size and arrangement of parts within the principles of the invention to the full extent

5

indicated by the broad general meaning of the terms in which the appended claims are expressed.

What is claimed is:

- [1.** An apparatus for storing an article, comprising:  
a tray having a bottom face that is adapted to be supported  
by an underlying surface such as a counter-top, and an  
upper face; and  
a plurality of pegs extending outwardly from said upper  
face, each of said pegs being sized and arranged so as to  
be able to support an article, and wherein  
each of said pegs are permanently mounted to said tray in  
such a manner as to be movable between a first storage  
position, wherein said entire peg is positioned adjacent  
to said upper face for storage and packaging of said  
apparatus, and a second, operative position, wherein  
said peg is positioned so as to extend outwardly from  
said upper surface, so as to enable said peg to support an  
article, wherein said apparatus can conveniently be  
folded for packaging and storage purposes.]
- [2.** An apparatus according to claim 1, wherein said pegs  
are mounted to said tray in such a manner that no standing  
water may collect at a point where a peg is mounted, thereby  
minimizing potential for mold and bacterial growth.]
- [3.** An apparatus according to claim 1, wherein said pegs  
are mounted to said tray in such a manner as to be movable  
only about a single axis of rotation.]
- [4.** An apparatus according to claim 3, further comprising  
means for imparting lateral stability to said pegs, further  
detrerring any motion other than about said single axis of  
rotation.]
- [5.** An apparatus according to claim 4, wherein said means  
for imparting lateral stability to said pegs comprises at least  
one axle joining adjacent pegs together for common, ganged  
movement about a common axis of rotation.]
- [6.** An apparatus according to claim 5, further comprising  
location means for locking said axle in a rotational position  
that corresponds to said second operative position.]
- [7.** An apparatus according to claim 6, wherein said loca-  
tion means comprises means, connected to said axle, for  
frictional engaging said upper surface of said tray.]
- [8.** An apparatus according to claim 1, further comprising a  
collection reservoir defined in said tray for collecting any  
liquid that might run out of articles during drying.]
- 9.** [An apparatus according to claim 1, further comprising]  
*An apparatus for storing an article, comprising:*  
*a tray having a bottom face that is adapted to be supported*  
*by an underlying surface, and an upper face; and*  
*a plurality of pegs extending outwardly from said upper*  
*face, each of said pegs being sized and arranged so as to*  
*be able to support an article,*  
disk holding means, connected to said upper face of said  
tray, for holding baby bottle disks in a location that is  
isolated from areas of said tray in which liquid may  
collect; and wherein  
each of said pegs are permanently mounted to said tray in  
such a manner as to be movable between a first storage  
position, wherein said entire peg is positioned adjacent  
to said upper face for storage and packaging of said  
apparatus, and a second, operative position, wherein  
said peg is positioned so as to extend outwardly from  
said upper surface, so as to enable said peg to support an  
article, wherein said apparatus can conveniently be  
folded for packaging and storage purposes.
- 10.** An apparatus according to claim 9, wherein said disk  
holding means comprises an upstanding boss member that is  
raised from said upper face of said tray, and a plurality of  
disk-receiving slots defined in said boss member.

6

**[11.** An apparatus according to claim 1, further comprising  
a plurality of ring support members that are constructed and  
arranged to support a ring portion of a baby bottle.]

**[12.** An apparatus according to claim 11, wherein said ring  
support members include a stop member for supporting a ring  
member above and out of contact from said upper face of said  
tray.]

**[13.** An apparatus according to claim 11, wherein said  
nipple support members are mounted to said tray in such a  
manner as to be movable between a first storage position,  
wherein said entire nipple support member is positioned adja-  
cent to said upper face for storage and packaging of said  
apparatus, and a second, operative position, wherein said  
nipple support member is positioned at a large angle with  
respect to said upper face.]

**[14.** An apparatus according to claim 13, wherein said  
nipple support members are mounted to said tray in such a  
manner as to be movable only about a single axis of rotation.]

**[15.** An apparatus according to claim 14, further compris-  
ing means for imparting lateral stability to said nipple support  
members, further detrerring any motion other than about said  
single axis of rotation.]

**[16.** An apparatus according to claim 15, wherein said  
means for imparting lateral stability to said nipple support  
members comprises at least one axle joining adjacent nipple  
support members together for common, ganged movement  
about a common axis of rotation.]

**[17.** An apparatus according to claim 16, further compris-  
ing location means for locking said axle in a rotational posi-  
tion that corresponds to said second operative position.]

**[18.** An apparatus according to claim 1, further comprising  
a cutout area on a side of said apparatus for facilitating lifting  
of said apparatus by a user.]

**19.** An apparatus for drying and storing an article, com-  
prising:

a tray having a bottom face that is adapted to be supported  
by an underlying surface [such as a counter-top,] and an  
upper face;

bottle support means for supporting a baby bottle; and  
disk holding means, connected to said upper face of said  
tray, for holding baby bottle disks in a location that is  
isolated from areas of said tray in which liquid may  
collect, whereby baby bottle disks are and stored in a  
safe manner at a location that is convenient to a location  
at which baby bottles are being dried.

**20.** An apparatus according to claim 19, wherein said disk  
holding means comprises an upstanding boss member that is  
raised from said upper face of said tray, and a plurality of  
disk-receiving slots defined in said boss member.

**21.** *An apparatus for supporting baby bottles for drying,*  
*comprising:*

*a tray having a bottom portion that is adapted to be sup-*  
*ported by an underlying surface and an upper portion;*  
*a plurality of pegs extending outwardly from said upper*  
*portion, each of said pegs being sized and arranged so as*  
*to be able to support a baby bottle;*

*mounting means for mounting said pegs to said tray so that*  
*said pegs are movable while mounted to said tray*  
*between a first storage position, wherein said entire peg*  
*is positioned adjacent to said upper portion for storage*  
*and packaging of said apparatus, and a second, opera-*  
*tive position, wherein said peg is positioned so as to*  
*extend outwardly from said upper portion, so as to*  
*enable said peg to support an article, wherein said appa-*  
*ratus can conveniently be folded for packaging and stor-*  
*age purposes;*



7

*frictional means connected to said pegs for frictionally engaging said upper portion of said tray when said pegs are moved between said first storage position and said second operative position; and*

*location means for locking said pegs in said second, operative position, said location means comprising a cam member having a first surface that is constructed and arranged to come into contact with a cam stop surface that is defined in said upper portion of said tray; and*

8

*wherein said frictional means comprises a second surface on said cam member, said second surface being constructed and arranged to bear against an upper portion of said tray that is on said upper portion when said peg is moved between said first storage position and said second operative position.*

\* \* \* \* \*