



US00RE43626E

(19) **United States**
(12) **Reissued Patent**
Tain et al.

(10) **Patent Number:** **US RE43,626 E**
(45) **Date of Reissued Patent:** **Sep. 4, 2012**

(54) **LED LAMP**

(58) **Field of Classification Search** 362/294,
362/373
See application file for complete search history.

(75) Inventors: **Ra-Min Tain**, Zhonghe (TW);
Tzong-Che Ho, Hsinchu (TW);
Shyi-Ching Liau, Qionglin Township
(TW)

(56) **References Cited**

(73) Assignee: **Transpacific IP I Ltd.**, Taipei (TW)

U.S. PATENT DOCUMENTS

(21) Appl. No.: **12/859,141**

(22) Filed: **Aug. 18, 2010**

5,857,767	A	1/1999	Hochstein
6,149,283	A	11/2000	Conway et al.
6,220,722	B1	4/2001	Begemann
6,577,073	B2	6/2003	Shimizu et al.
6,617,616	B2	9/2003	Shibuya
6,663,248	B2	12/2003	Hsieh
6,864,513	B2	3/2005	Lin et al.
7,086,767	B2	8/2006	Sidwell et al.
7,097,317	B2	8/2006	Kim
7,144,135	B2	12/2006	Martin et al.
7,259,403	B2 *	8/2007	Shimizu et al. 257/99
7,314,291	B2	1/2008	Tain et al.
2006/0001384	A1	1/2006	Tain et al.

Related U.S. Patent Documents

Reissue of:

(64) Patent No.: **7,413,326**
Issued: **Aug. 19, 2008**
Appl. No.: **11/851,930**
Filed: **Sep. 7, 2007**

* cited by examiner

U.S. Applications:

(63) Continuation of application No. 10/963,401, filed on
Oct. 12, 2004, now Pat. No. 7,314,291.

Primary Examiner — Stephen F Husar

Assistant Examiner — James Cranson, Jr.

(74) *Attorney, Agent, or Firm* — Knobbe, Martens, Olson &
Bear LLP

(30) **Foreign Application Priority Data**

Jun. 30, 2004 (TW) 93119800 A

(57) **ABSTRACT**

(51) **Int. Cl.**
F21V 29/00 (2006.01)
H01L 29/22 (2006.01)

An LED lamp includes LED chips, an axle, and a lampshade. The LED chips are mounted on surface of the axle. The axle which is coupled to the lampshade includes heat pipes for transferring the heat generated by the LED chips to exterior of the lampshade and obtaining a better heat dissipation.

(52) **U.S. Cl.** 362/294; 362/373

22 Claims, 8 Drawing Sheets

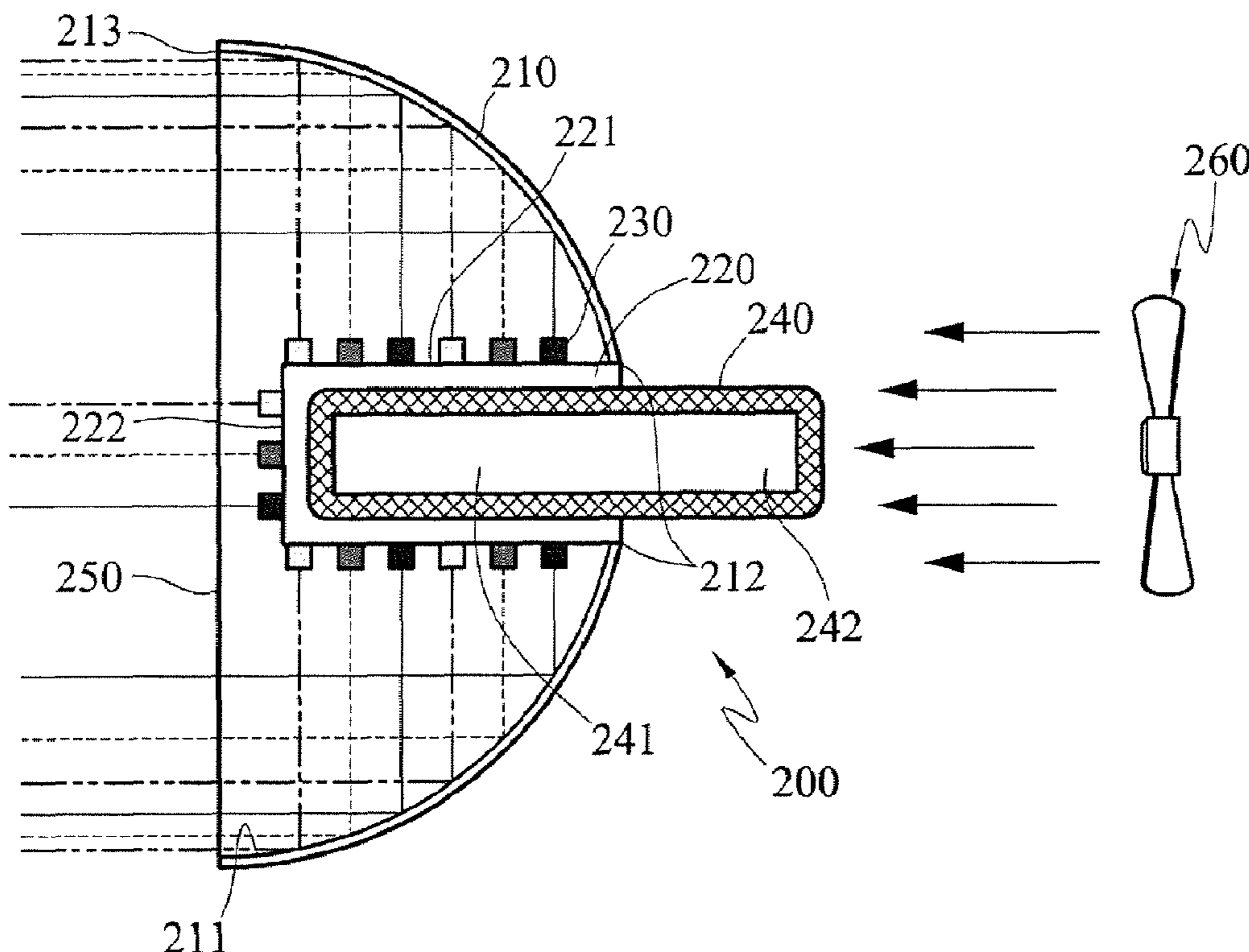

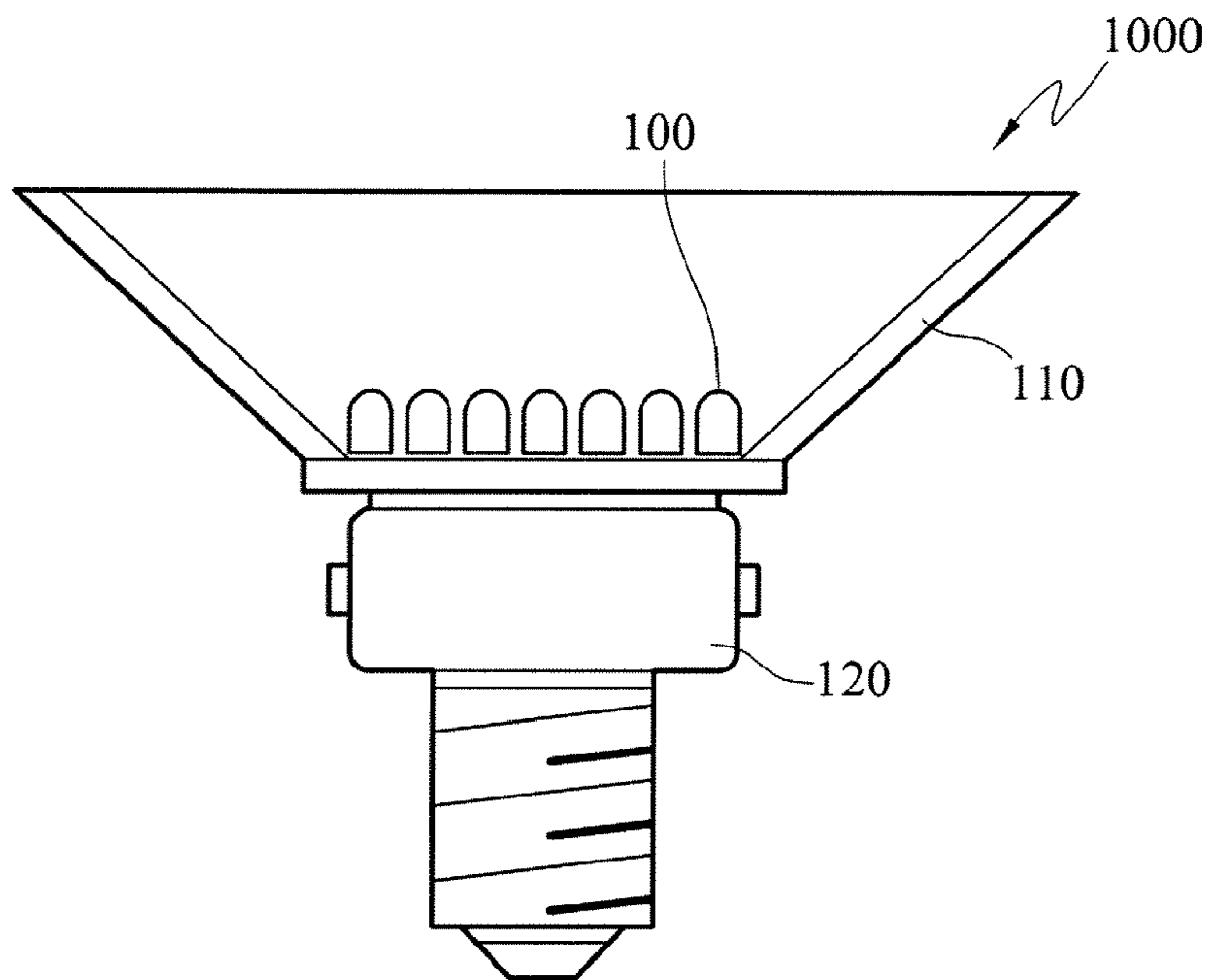

FIG. 1 (PRIOR ART)

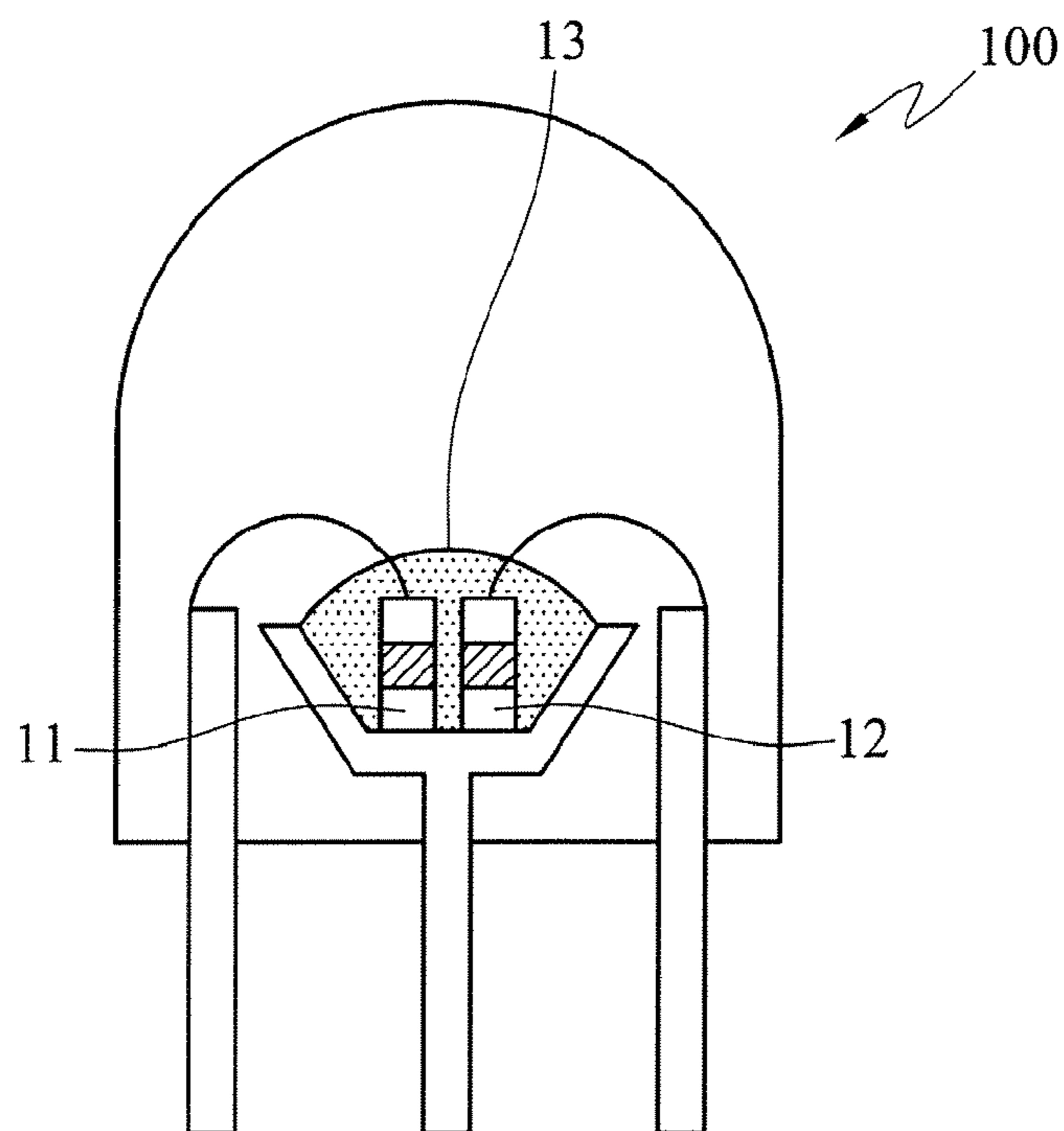

FIG. 2 (PRIOR ART)

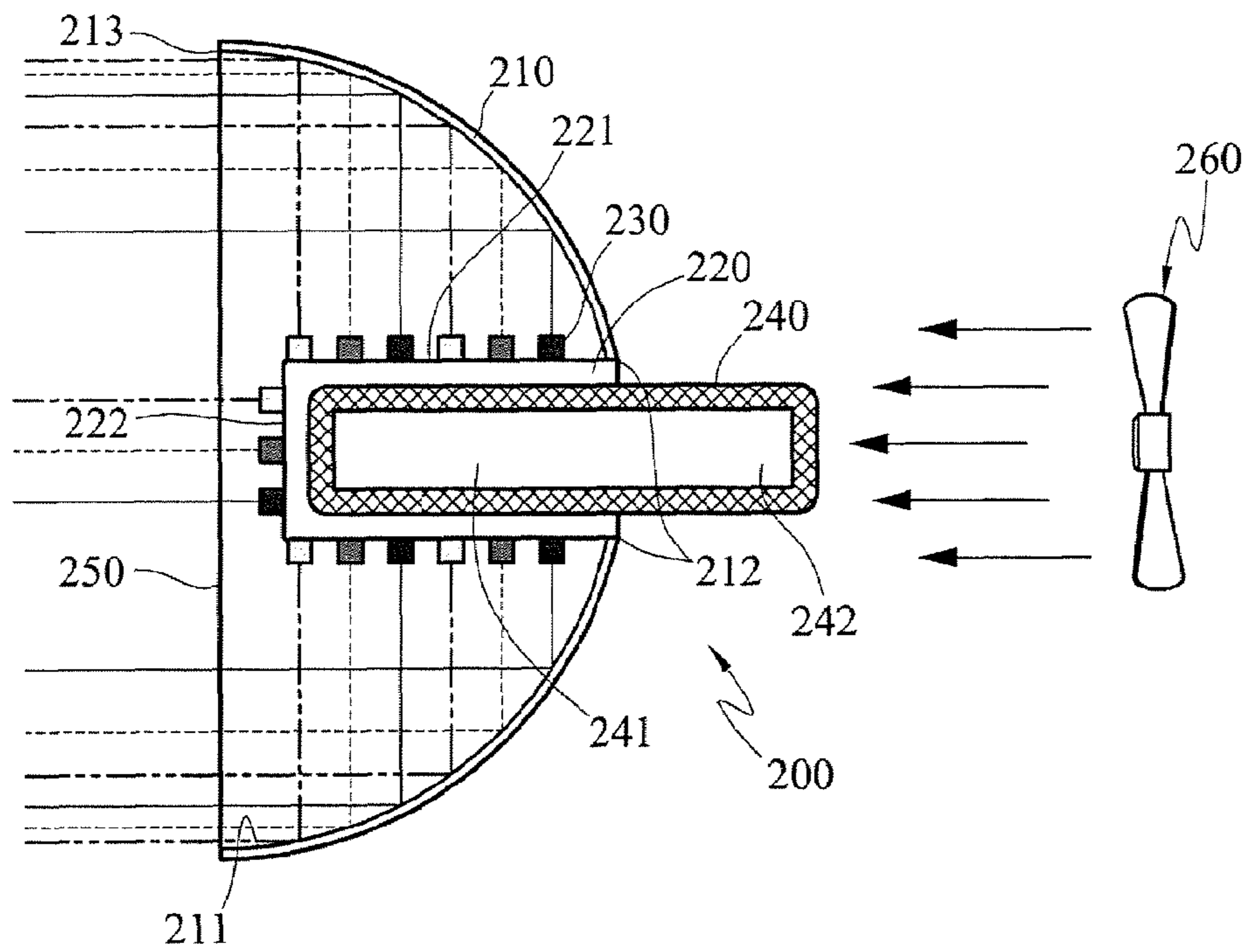

FIG. 3A

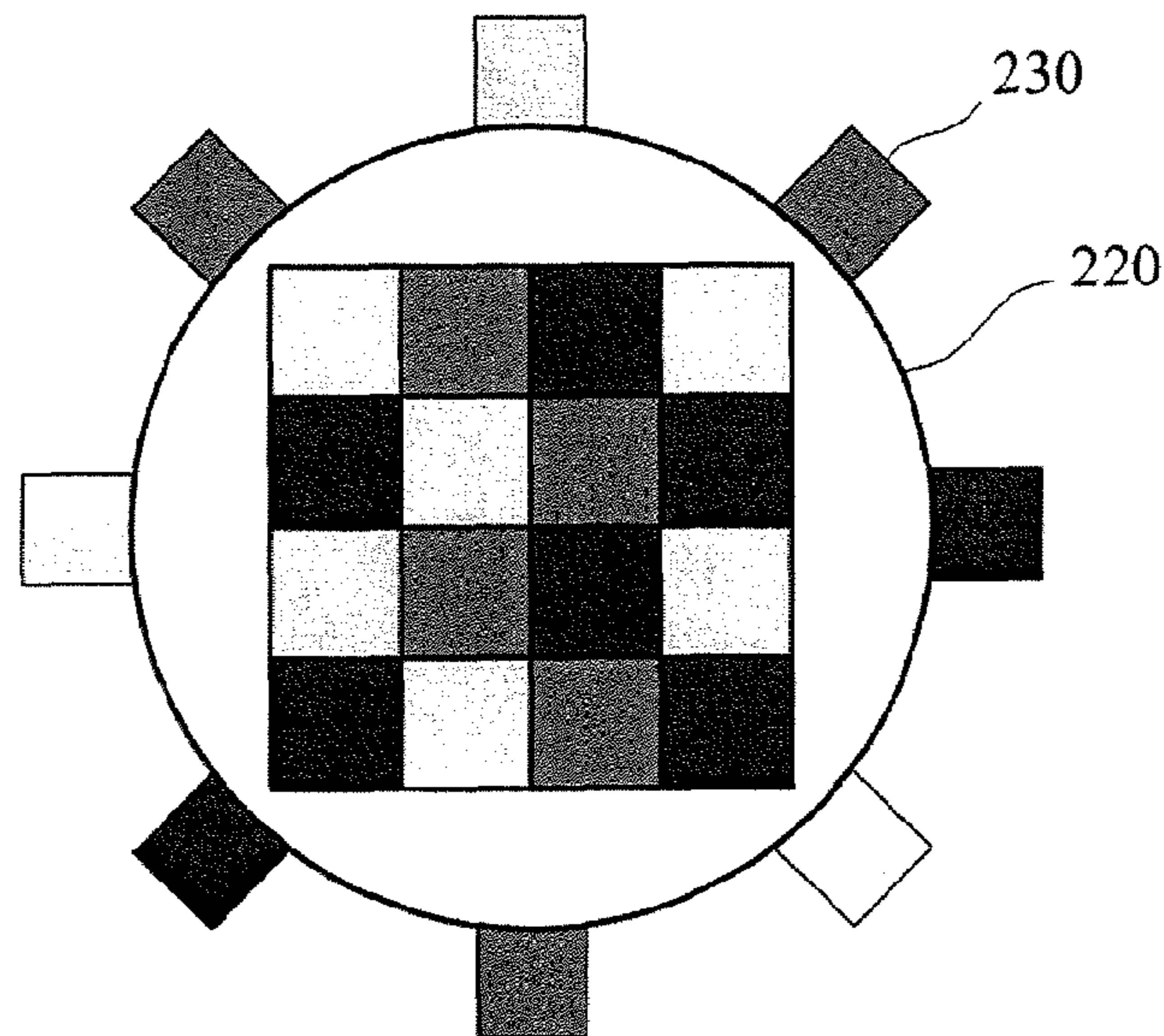
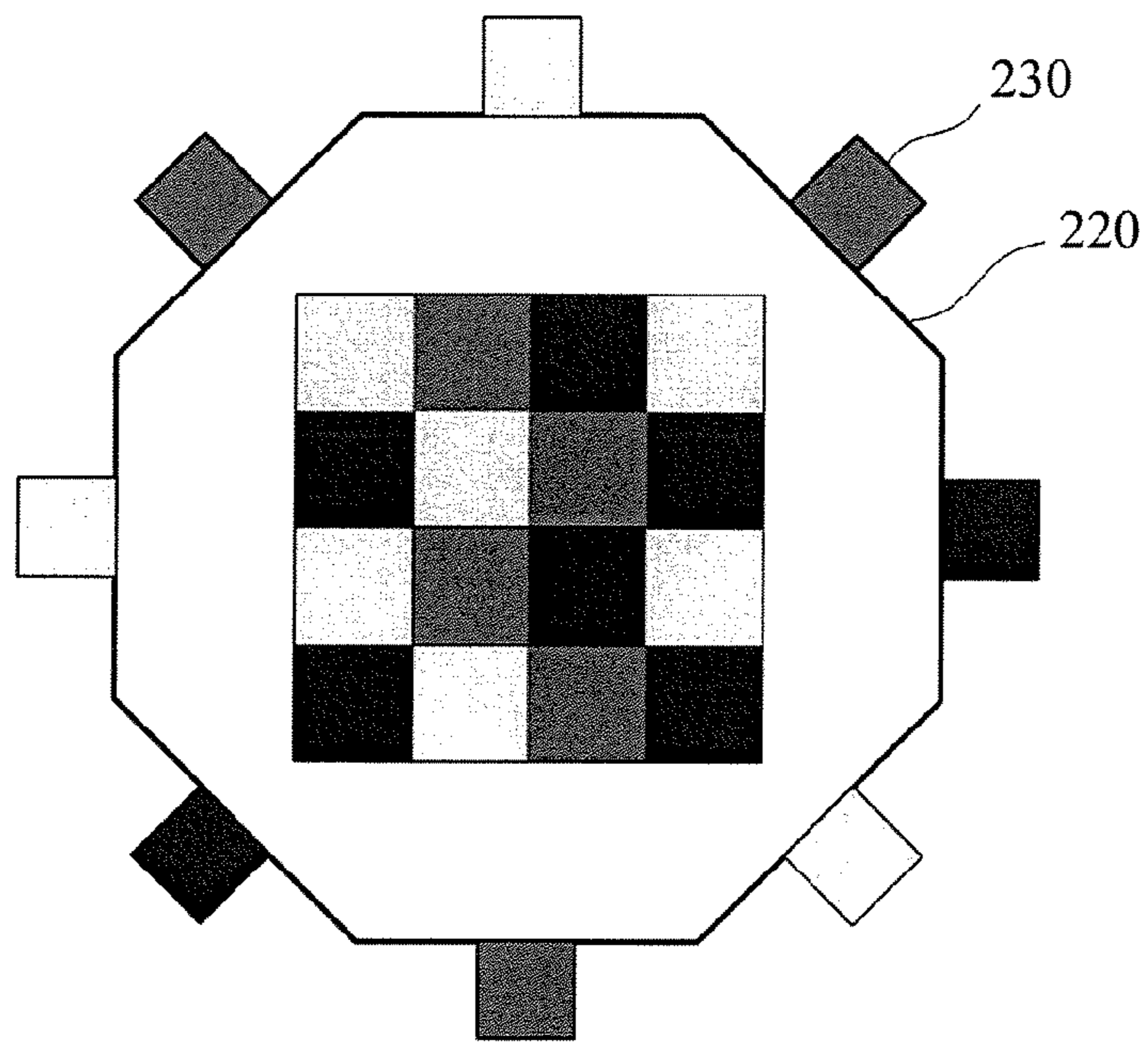
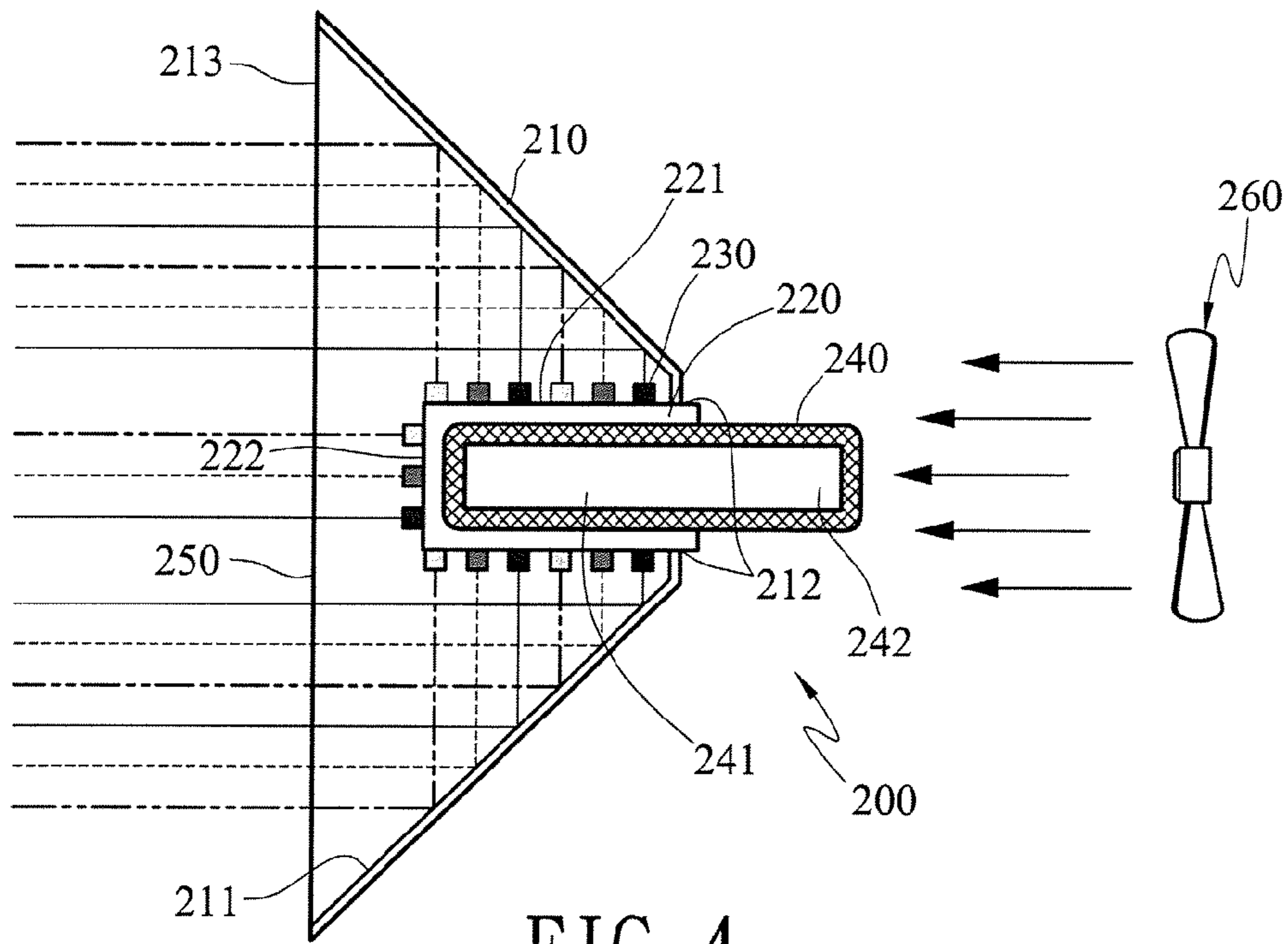

FIG. 3B



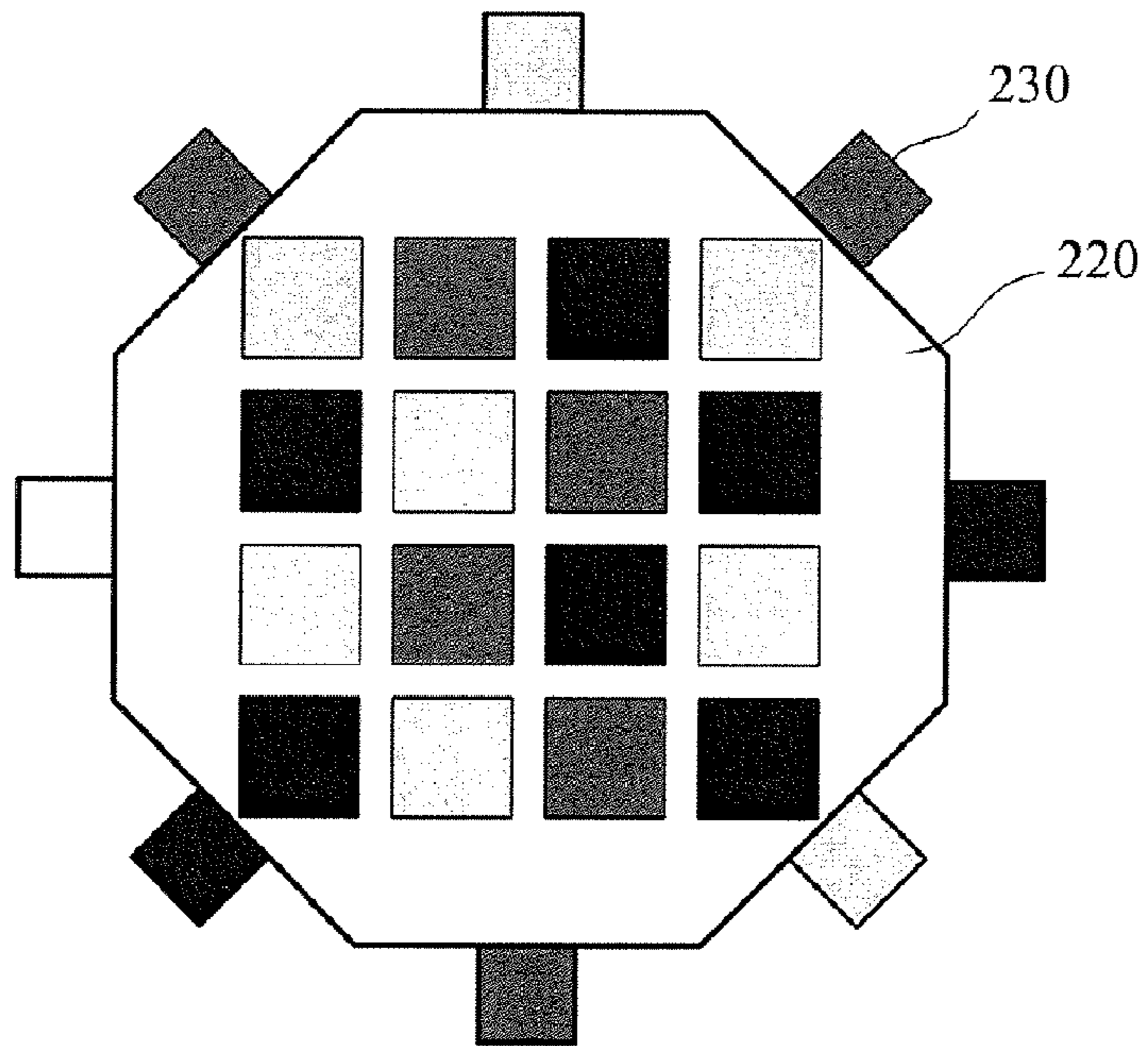

FIG. 6

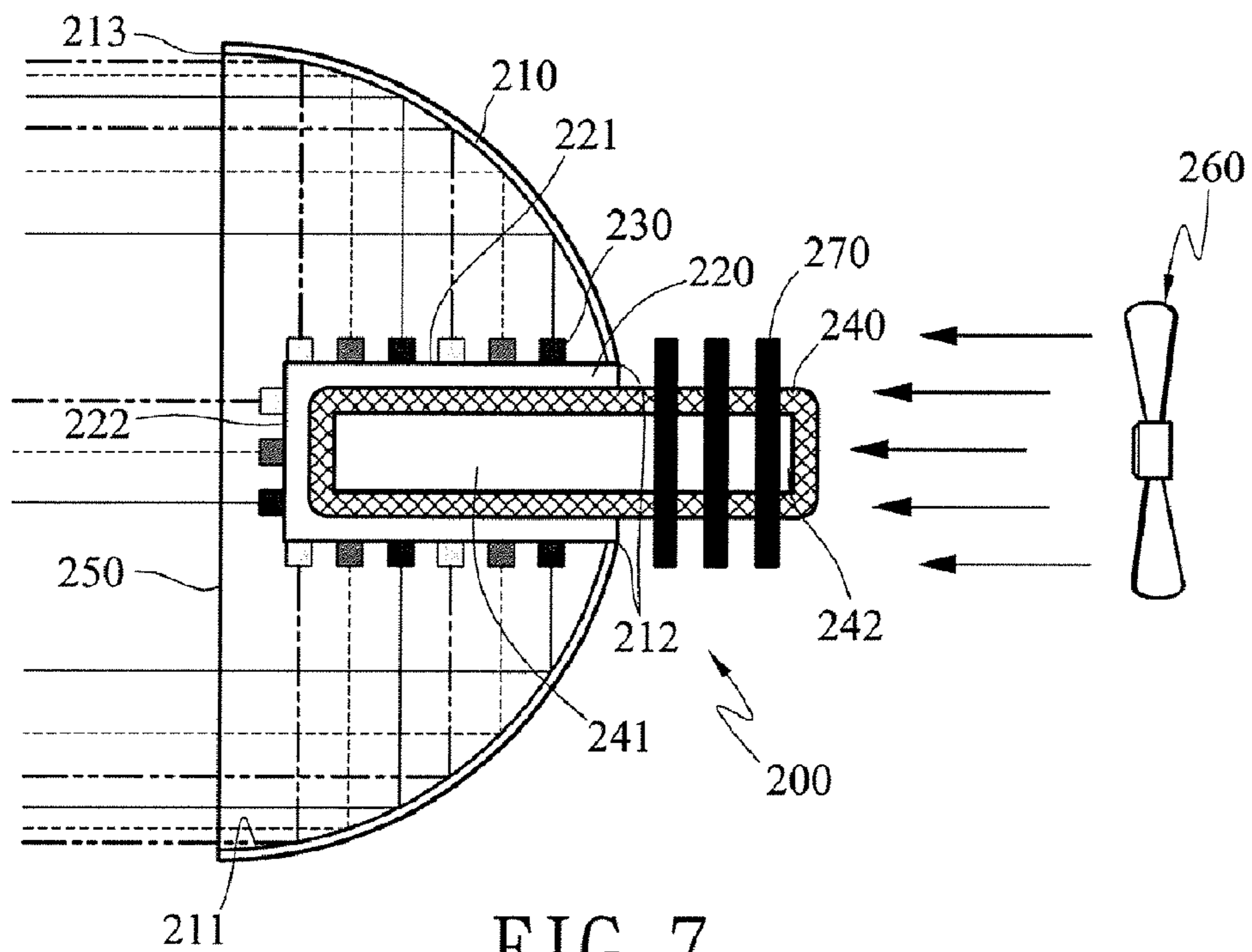

FIG. 7

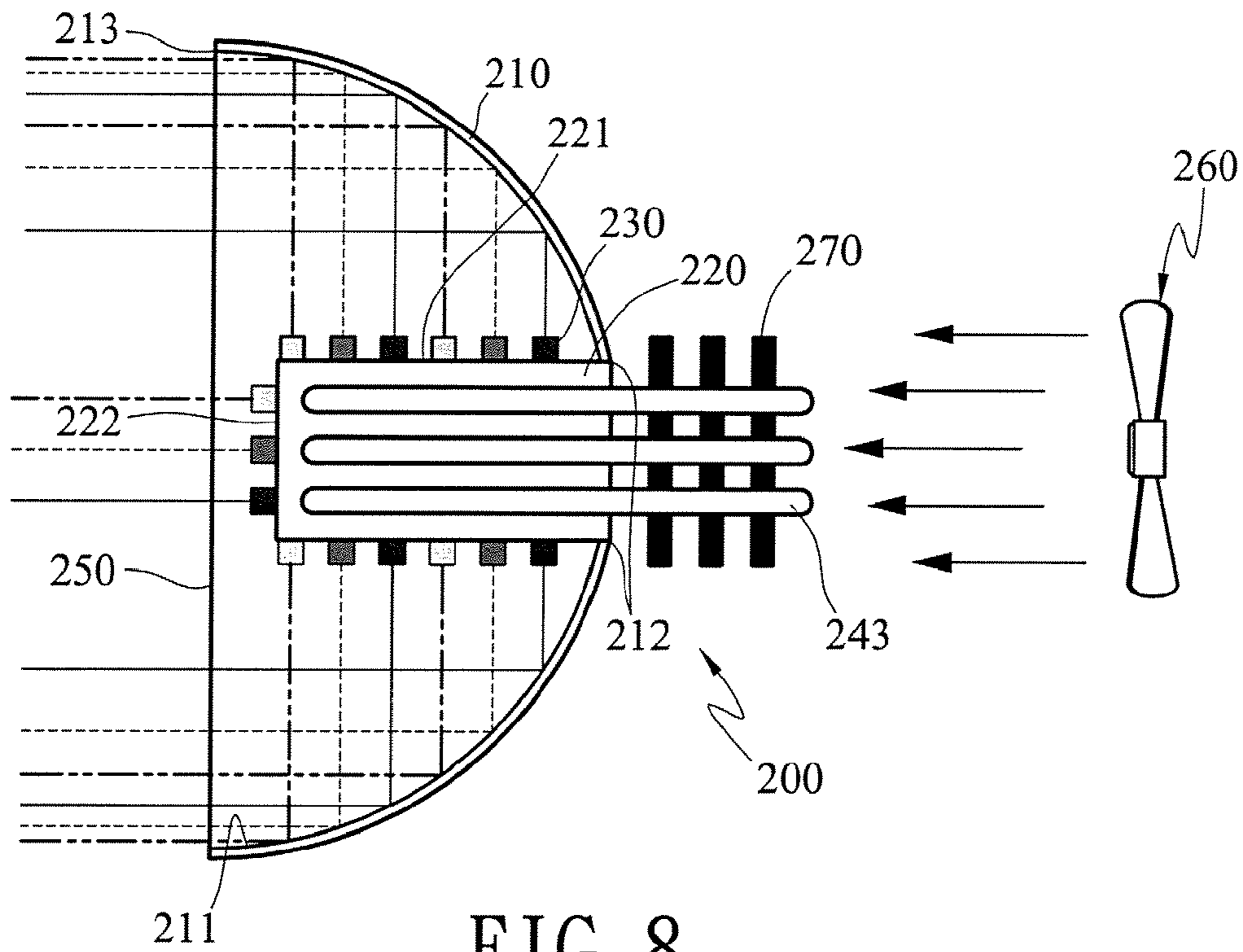

FIG. 8

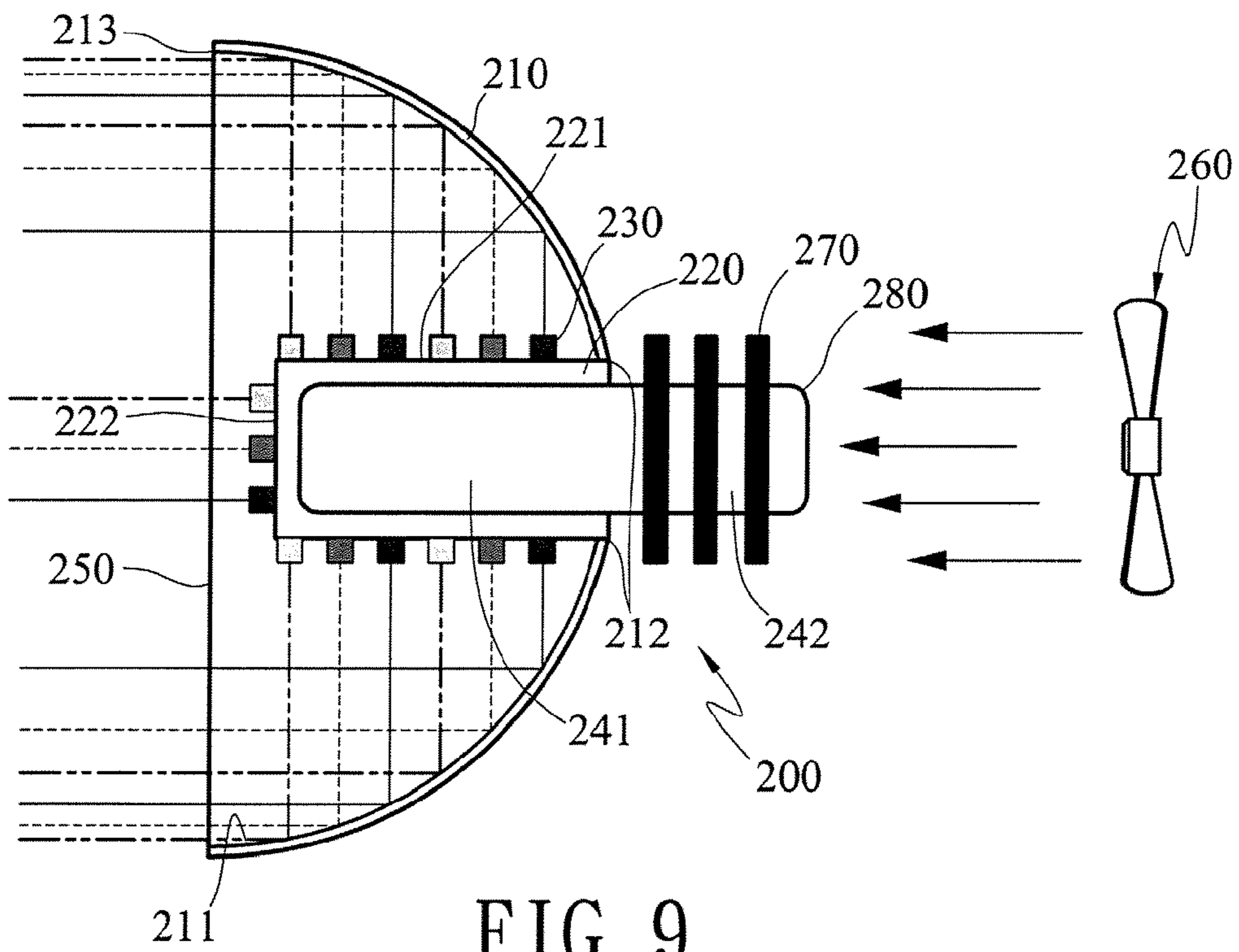
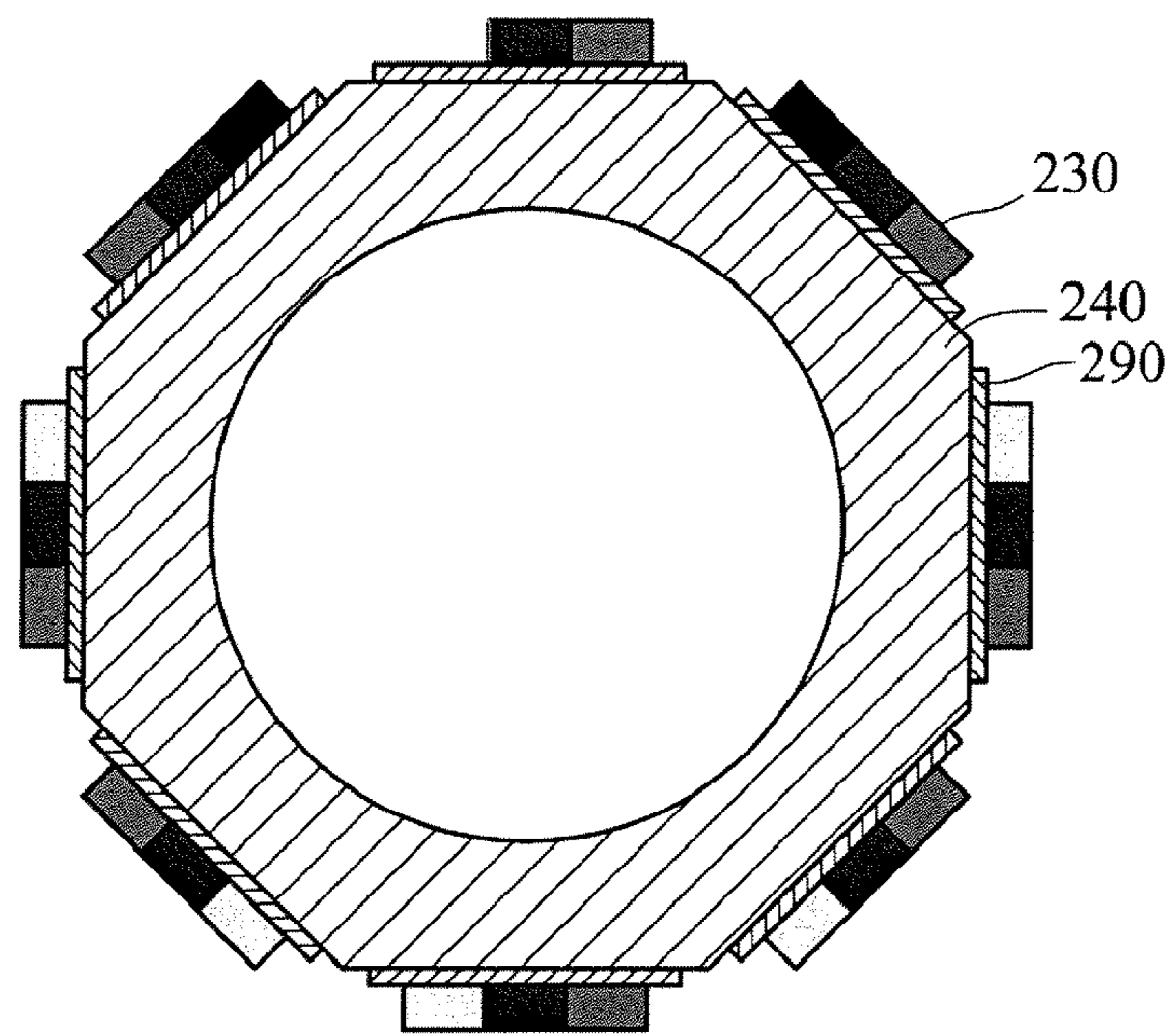
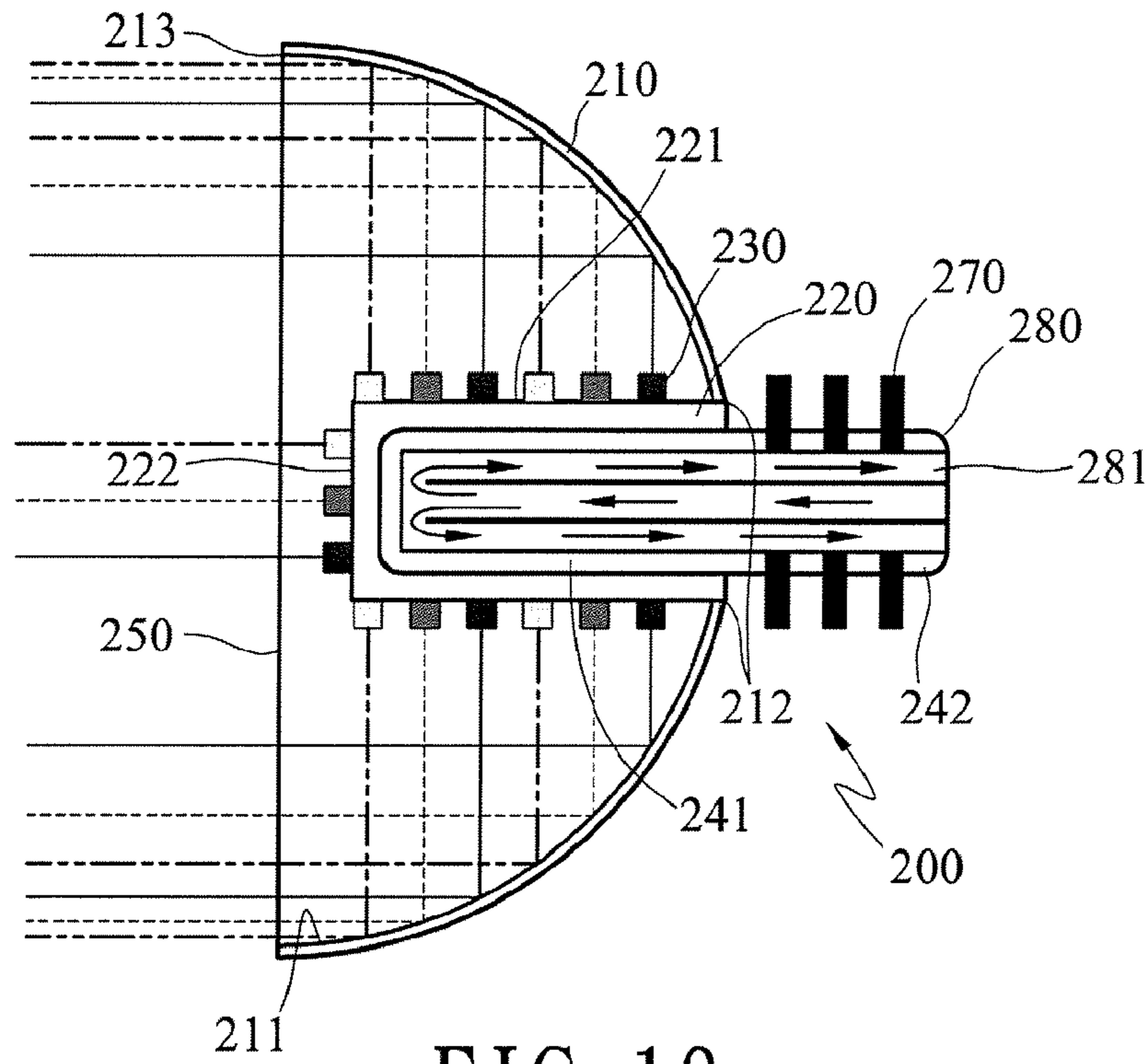

FIG. 9



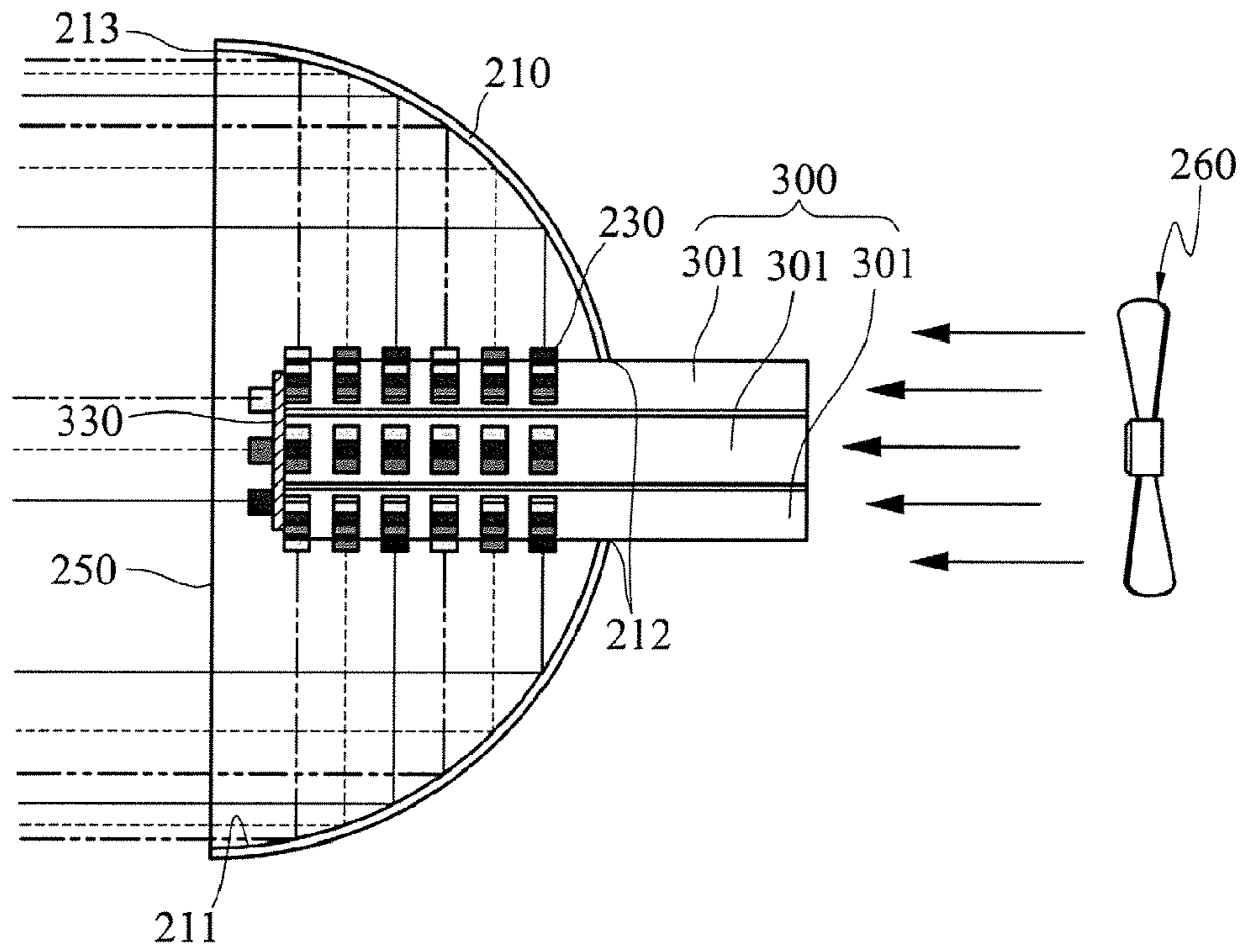

FIG. 12A

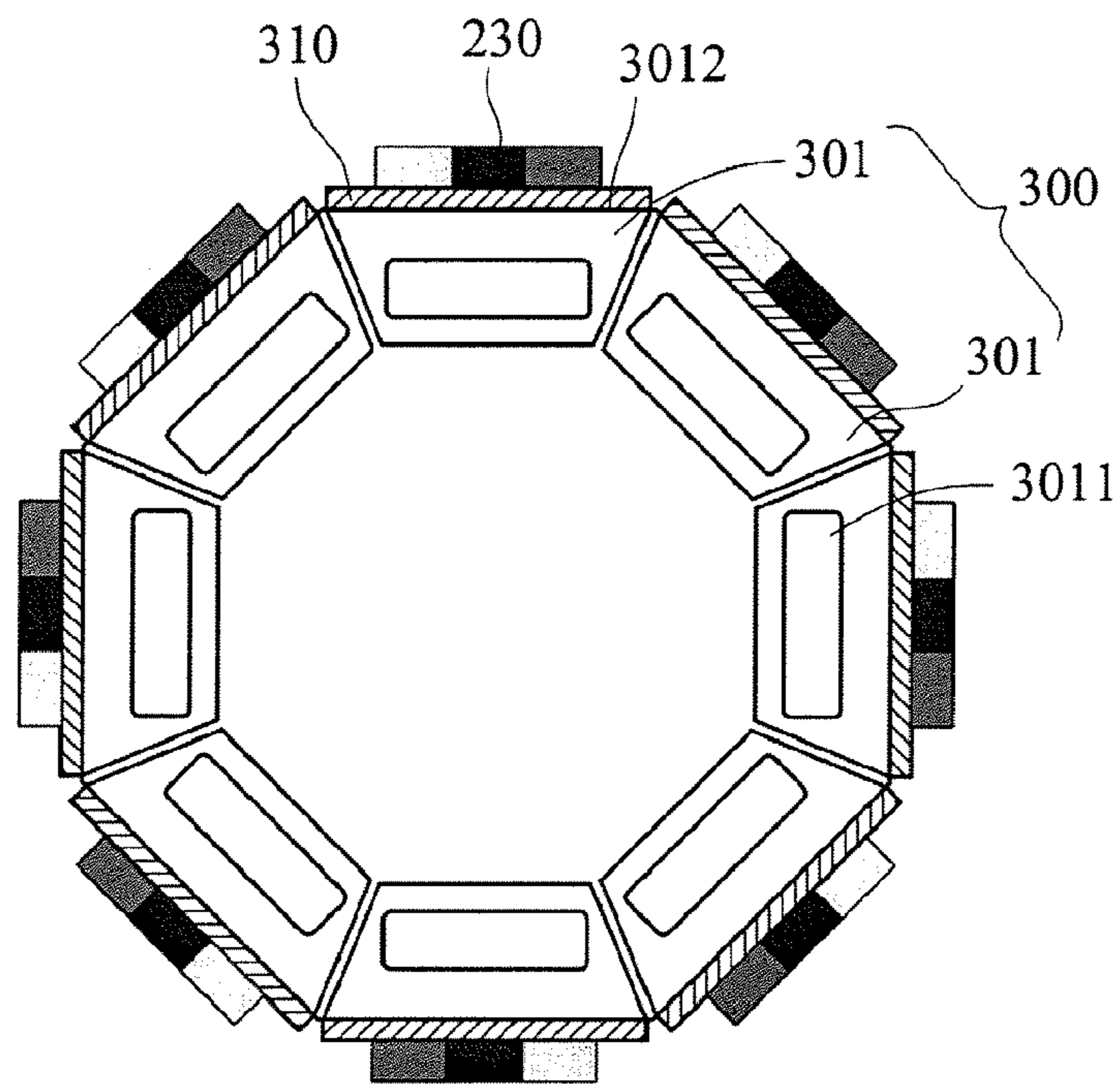

FIG. 12B

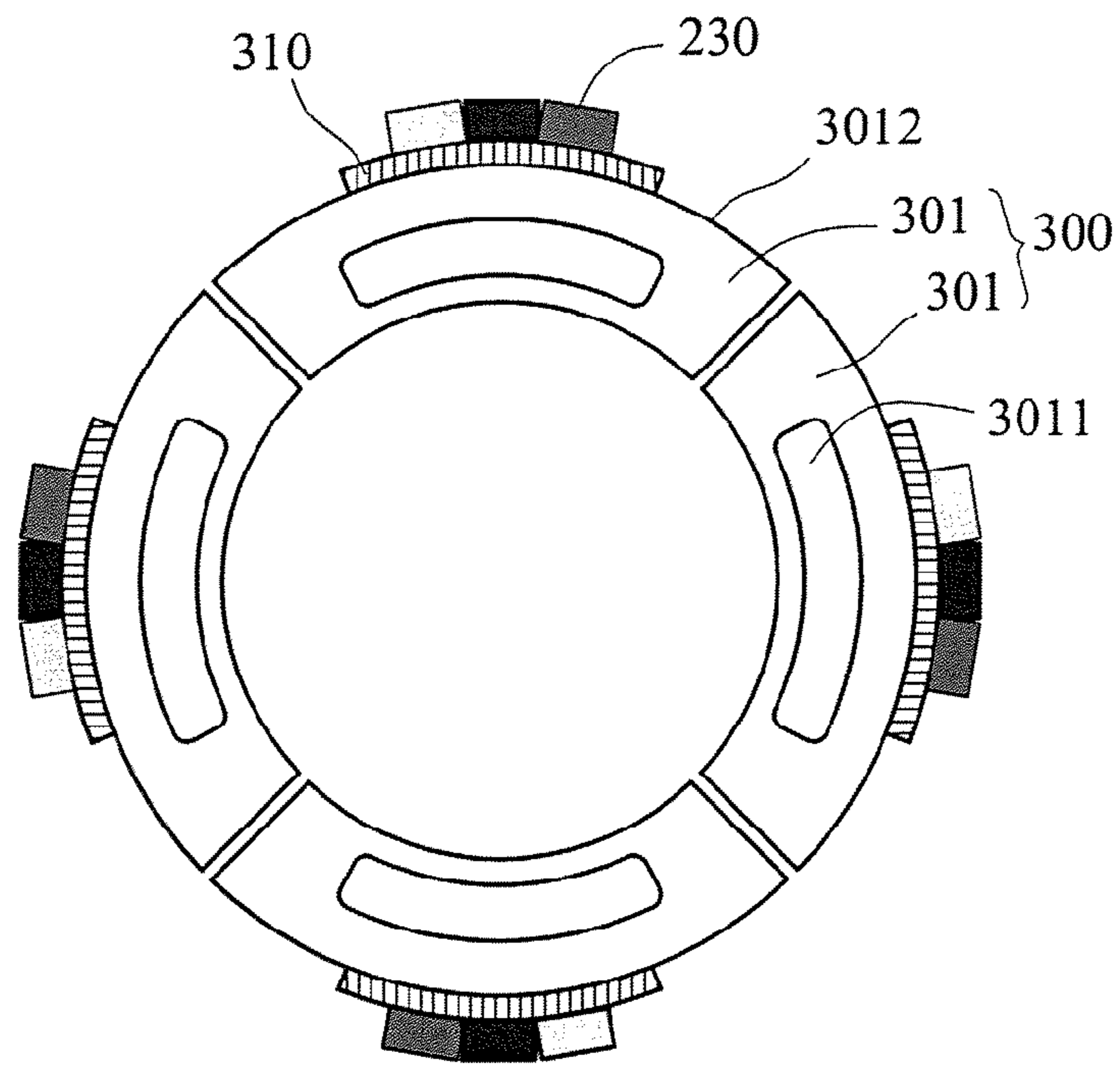

FIG. 13

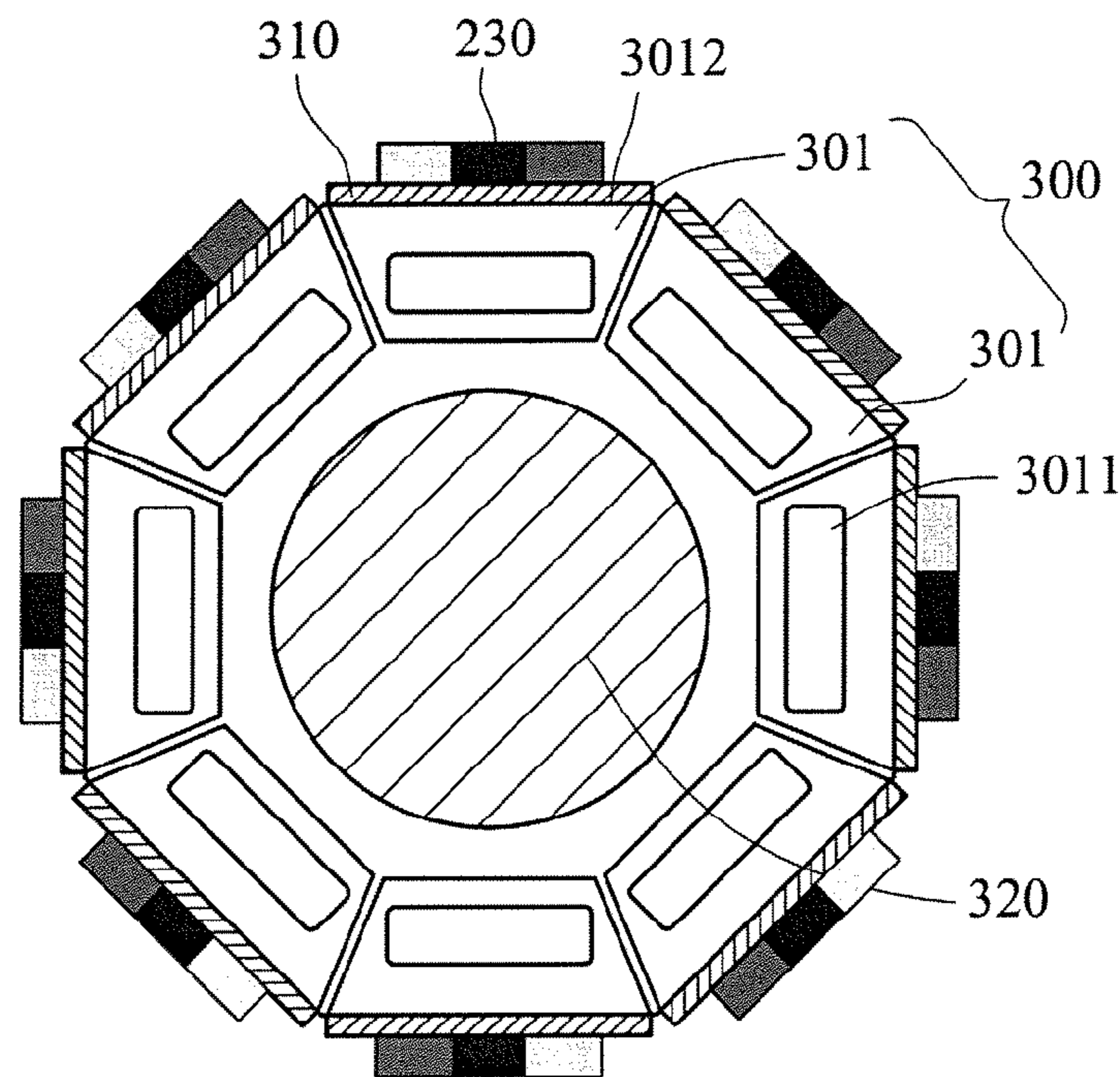

FIG. 14

1

LED LAMP

Matter enclosed in heavy brackets [] appears in the original patent but forms no part of this reissue specification; matter printed in italics indicates the additions made by reissue.

CROSS REFERENCE TO RELATED APPLICATION

This is a continuation of parent application Ser. No. 10/963,401, filed Oct. 12, 2004 now U.S. Pat. No. 7,314,291. The entire disclosure of the parent application is incorporated herein by reference.

FIELD OF THE INVENTION

The invention generally relates to an LED lamp, and in particular relates to an LED lamp applying heat pipe for heat dissipation.

BACKGROUND OF THE INVENTION

Light emitting diode (LED) is a highly efficient device to transform electric energy into light in comparison to conventional incandescent bulbs. The most important part of an LED is the semi-conductor chip located in the center of the bulb. The LED chip has two regions separated by a junction. The p region is dominated by positive electric charges, and the n region is dominated by negative electric charges. The junction acts as a barrier to the flow of electrons between the p and the n regions. Only when sufficient voltage is applied to the semi-conductor chip, can the current flow, and the electrons cross the junction into the p region. When an electron moves sufficiently close to a positive charge in the p region, the two charges "re-combine". Each time an electron recombines with a positive charge, electric potential energy is converted into electromagnetic energy. For each recombination of a negative and a positive charge, a quantum of electromagnetic energy is emitted in the form of a photon of light.

LEDs have advantages of small size, low driving voltage, fast response, resistance to vibration and long service life. They do dozens of different jobs and are found in all kinds of devices. Among other things, they form the numbers on digital clocks, transmit information from remote controls, light up watches and tell you when your appliances are turned on. Collected together, they can form images on a jumbo television screen or illuminate a traffic light.

Common LED lamps usually can be divided into two kinds of monochromatic light and polychromatic light. The polychromatic light LED lamp usually includes several lamps being able to provide different colored lights under individual controls so as to perform blends of light change.

As shown in FIG. 1, a side view of an LED lamp unit disclosed in U.S. Pat. No. 6,577,073, a lamp unit **1000** mainly includes LED lamps **100**, a reflector **110** and a power supply **120**. The reflector **110** reflects the light produced from the LED lamps **100**. The power supply **120** supplies power to the lamps **100**. A number of, typically 10 to 200, LED lamps **100** are arranged on the bottom of the reflector **110** to provide the required luminosity. As shown in FIG. 2, each LED lamp includes blue and red LEDs and a phosphor. The blue LED produces an emission at a wavelength falling within a blue wavelength range. The red LED produces an emission at a wavelength falling within a red wavelength range. The phosphor is photoexcited by the emission of the blue LED to

2

exhibit a luminescence having an emission spectrum in an intermediate wavelength range between the blue and red wavelength ranges.

In each LED lamp **100**, the blue and red LEDs and the phosphor are integrated together within a single envelope. The lamp unit **1000** is composed of a plurality of such LED lamps. In comparison with prior arts that individual LED of monochromatic light being used, the LED lamp **100** of the prior patent saves about half of the space and cost of package.

However, in FIG. 1, the whole assembly of the plurality of LED lamps **100** in envelopes still occupies much area and decreases the number of possible LED lamps in the cluster and the luminosity of the lamp unit **1000** in the limited space.

There is further a problem that when arranging the LED lamps **100** tightly to get higher luminosity, the heat generated from the LED lamps is hard to be dissipated. The reflector **110** thermally coupled through solid conduction to the LED lamps **100** is insufficient for dissipating the heat. The heat accumulation will influence the service life of the lamp unit **1000**.

SUMMARY OF THE INVENTION

In view of the aforesaid problems, the invention provides an LED lamp applicable to spotlight, headlight, house lamp, street lamp and so on. The LED lamp mainly includes a lampshade, an axle, LED chips, a driving circuit and a heat pipe.

The lampshade can be a bowl-shaped structure having a concave surface, a central hole and an opening. The surface can be used to reflect the light emitted from the LED chips. To achieve a better reflection, the surface is coated with a reflective film of suitable material.

The central hole is formed on bottom of the lampshade for receiving the axle and the heat pipe passing through. This heat pipe protrudes across both sides of the lampshade. A transparent plate is formed on the opening of the lampshade for enabling the light to pass through while preventing dust, insect or the like entering the lampshade and influencing the service life of the LED chips.

The material of the axle can be chosen from general printed circuit boards, ceramics or other electrically insulative while thermally conductive material. The heat pipe passes the central hole into the lampshade, and being defined with a heat receiving portion and a heat dissipation portion. The heat receiving portion is covered by the lampshade where the LED chips emit light and heat.

Several LED chips are mounted on surface of the axle and corresponding to the heat receiving portion of the heat pipe, including the exterior axial surface of the axle and the end surface facing the transparent plate. The color, number and arrangement of the LED chips can be designed by user for achieving specific light effects.

The characteristics of the invention are that the LED chips can be bare chips without packages as prior arts. Therefore, the quantity of LED chips capable of being arranged in the limited area can be increased so as to increase the luminosity. Meanwhile, the cost and time of packaging the LED chips individually are also saved.

The driving circuit is embedded in the axle for actuating the LED chips individually, controlling the brightness and color blending of the LED lamp, and preventing static electricity to damage the LED chips. The LED chips are electrically connected to the driving circuit through embedding, wire bonding or other methods.

The heat pipe is installed along the axle for dissipating the heat generated by the LED chips from the heat receiving

portion to the heat dissipation portion. The heat pipe is able to transport heat by an evaporation-condensation cycle with the help of porous capillaries. It dissipates the heat at the heat dissipation portion via natural convection or additional cooling fan, and solves the problem of heat accumulation in the LED chips.

BRIEF DESCRIPTION OF THE DRAWINGS

The invention will become more fully understood from the detailed description given hereinbelow. However, this description is for purposes of illustration only, and thus is not limitative of the invention, wherein:

FIG. 1 is a side view of an LED lamp unit disclosed in U.S. Pat. No. 6,577,073;

FIG. 2 is a side view of an LED lamp used in a lamp unit of U.S. Pat. No. 6,577,073;

FIGS. 3A and 3B are side view and front view of an LED lamp of a first embodiment of the invention;

FIG. 4 is a sectional view of a pyramid lampshade in an LED lamp of the invention;

FIG. 5 is a front view of a polygon axle in an LED lamp of the invention;

FIG. 6 is a front view of an axle where LED chips are dispersedly arranged;

FIG. 7 is a side view of an LED lamp of a second embodiment of the invention;

FIG. 8 is a side view of an LED lamp of a third embodiment of the invention;

FIG. 9 is a side view of an LED lamp of a fourth embodiment of the invention;

FIG. 10 is a side view of an LED lamp of a fifth embodiment of the invention;

FIG. 11 is a front view of an LED lamp of a sixth embodiment of the invention;

FIGS. 12A and 12B are side view and front view of an LED lamp of a seventh embodiment of the invention;

FIG. 13 is a front view of four quarters of circular heat pipes of an LED lamp of the invention; and

FIG. 14 is a sectional front view of an axle that includes a core.

DETAILED DESCRIPTION OF THE INVENTION

As shown in FIGS. 3A and 3B, a side view and a front view of an LED lamp in a first embodiment of the invention, the LED lamp 200 mainly includes a lampshade 210, an axle 220, LED chips 230, a driving circuit (not shown) and a heat pipe 240.

The lampshade 210 is a bowl-shaped construction having a concave surface 211, a central hole 212 and an opening 213. The concave surface 211 is used to reflect the light emitted from the LED chips 230 toward the opening 213 of the lampshade 210. To achieve a better reflection, the surface 211 is coated with a reflective film of suitable material or has been polished to reflect light. The central hole 212 is formed on bottom of the lampshade 210 for receiving the axle 220 and the heat pipe 240 passing through.

A transparent plate 250 is mounted on the opening 213 of the lampshade 210 for enabling the light emitted from the LED chips 230 to pass through while preventing dust, insect or the like entering the lampshade 210 and influencing the service life of the LED chips 230. The transparent plate 250 can also be processed with diffusion patterns, light-enhancing film, polarization film and so on for achieving different light effects.

The shape of the lampshade 210 is not limited to spherical but also be a pyramid as shown in FIG. 4, or other concave shapes.

The axle 220 passes the central hole 212 and extrudes into the lampshade 210. The material of the axle 220 can be chosen from general printed circuit boards, ceramics or other electrically insulative while thermally conductive material.

The heat pipe 240 passes the central hole into the lampshade 210 and being defined with a heat receiving portion 241 (at the left side of the drawing) and a heat dissipation portion 242 (at the right side of drawing). The heat receiving portion 241 is covered by the lampshade 210 where the LED chips 230 emit light and heat.

Several LED chips 230 are mounted on surface of the axle 220 and corresponding to the heat receiving portion 241 of the heat pipe 240, including the exterior axial surface 221 of the axle 220 and the end surface 222 facing the transparent plate 250.

The driving circuit (not shown in the drawing) is embedded in the axle 220 for activating the LED chips 230 individually, controlling the brightness and color blending of the LED lamp 200, and preventing static electricity to damage the LED chips 230. The LED chips 230 are electrically connected to the driving circuit through embedding, wire bonding or other methods.

When using printed circuit board to make the axle 220, the driving circuit can be made with stacks inside the axle 220, or printed on surface of the axle 220. When the axle 220 is not made by printed circuit board, the surface of the axle 220 can be covered with a printed circuit to achieve the same function.

In order to prevent oxidization of the LED chips 230 caused by direct exposure to the air, the space enclosed by the lampshade 210 and the transparent plate 250 can be filled with nitrogen or other inert gas. Or, the surface of the LED chips 230 is coated with a transparent material, such as epoxy or silicone. Another method is to vacuum the space enclosed by the lampshade 210 and the transparent plate 250 and to prevent the LED chips 230 from reaction with air.

The characteristics of the invention are that the LED chips 230 are bare chips without packages as prior arts. Therefore, the quantity of LED chips 230 capable of being arranged in the limited area can be increased so as to increase the luminosity. Meanwhile, the cost and time of packaging the LED chips 230 individually are also saved so as to improve the manufacturing efficiency of the LED lamp 200.

The LED chips 230 mounted on the axle 220 can be of monochromatic light or polychromatic light. When using LED chips 230 of different colors, the different color LED chips 230 (for example of red, blue and green lights) are interposed so that the adjacent LED chips 230 can be controlled to provide different colors of light for different light effects of the LED lamp 200.

The heat pipe 240 is installed along the axle 220 for dissipating the heat generated by the LED chips 230 from the heat receiving portion 241 to the heat dissipation portion 242. The heat pipe 240 is able to transport heat by an evaporation-condensation cycle with the help of porous capillaries. It dissipates the heat at the heat dissipation portion 242 via natural convection or an additional cooling fan 260, and solves the problem of heat accumulation in the LED chips 230.

The heat pipe 240 works with liquid and gas phase transitions of a working fluid sealed inside the heat pipe. It has a thermal conductivity dozens of times to that of copper. Therefore, the heat applied to the heat receiving portion 241 of the heat pipe 240 is fast transferred to the heat dissipation portion 242.

5

The section of the axle **220** is not limited to circular as shown in FIG. 3B, but can also be polygons as shown in FIG. 5, or any other suitable shape.

The arrangement of the LED chips **230** on the axle **220** can be tight as shown in FIG. 3B, or be dispersed as shown in FIG. 6 for different light effects.

Now referring to FIG. 7, a second embodiment of the invention, the LED lamp is similar to the first embodiment but having radiation fins **270** mounted on the end of heat pipe **240** for dissipating the heat transferred to the heat dissipating portion **242**. In accompany with an additional fan **260** to expel airflow, higher efficiency heat dissipation is achieved.

The LED chips **230** can be of monochromic light or polychromatic light. When using LED chips **230** of different colors, the different color LED chips **230** (for example of red, blue and green lights) are interposed so that the adjacent LED chips **230** can be controlled to provide different colors of light for different light effects of the LED lamp. The arrangement of the LED chips can be tight or dispersed.

As shown in FIG. 8, the heat pipe **240** is replaced with several heat pipes **243** of smaller dimensions to get the same function.

FIG. 9 is a side view of an LED lamp of a fourth embodiment of the invention. The LED lamp is similar to the first embodiment but the heat pipe **240** of FIG. 3 being replaced with a thermally conductive rod (such as a copper rod) **280** for dissipating the heat transferred from the heat receiving portion **241** to the heat dissipating portion **242**. Similarly, several radiations fins **270** can be mounted on the end of the rod **280** to obtain higher efficiency heat dissipation.

The LED chips **230** can be of monochromic light or polychromatic light. When using LED chips **230** of different colors, the different color LED chips **230** (for example of red, blue and green lights) are interposed so that the adjacent LED chips **230** can be controlled to provide different colors of light for different light effects of the LED lamp. The arrangement of the LED chips can be tight or dispersed.

FIG. 10 is a side view of an LED lamp of a fifth embodiment of the invention. The LED lamp is similar to the fourth embodiment but having a plurality of small passages formed in parallel in the thermally conductive rod **280** and allowing fluid to flow inside of the passages for heat transfer purpose. The fluid can be gas or liquid for transferring the heat from the heat receiving portion **241** to the heat dissipating portion **242**.

The LED chips **230** can be of monochromic light or polychromatic light. When using LED chips **230** of different colors, the different color LED chips **230** (for example of red, blue and green lights) are interposed so that the adjacent LED chips **230** can be controlled to provide different colors of light for different light effects of the LED lamp. The arrangement of the LED chips can be tight or dispersed.

FIG. 11 is a front view of an LED lamp of a sixth embodiment of the invention. The LED lamp **200** is simplified from the first embodiment. An insulation layer **290** is formed outside the heat pipe **240** for the LED chips **230** to be mounted on. The arrangement of the LED chips can be tight or dispersed.

The LED chips **230** can be of monochromic light or polychromatic light. When using LED chips **230** of different colors, the different color LED chips **230** (for example of red, blue and green lights) are interposed so that the adjacent LED chips **230** can be controlled to provide different colors of light for different light effects of the LED lamp. The arrangement of the LED chips can be tight or dispersed.

FIGS. 12A and 12B are side view and front view of an LED lamp of a seventh embodiment of the invention. The axle **300** has a different construction from the aforesaid embodiments.

6

The axle **300** is composed of eight heat pipes **301** each having a trapezoid section so as to form the axle **300** an octagon section with a hollow core. An end plate **330** is mounted on front end of the axle **300** and facing the transparent cover **250**.

Of course, the heat pipes **301** of the axle **300** are not limited to the octagon section. They can be of quarters of a circle as shown in FIG. 13, or other sections to form an axle **300** with circular, hexagon or other polygon sections.

A fluid conduit **3011** is formed inside each heat pipe **301** for performing liquid and gas phase cycles and removing the heat from the LED chips **230**. The exterior surface **3012** of each heat pipe **301** is covered with a layer of printed circuit board **310**. The driving circuit (not shown in the drawing) is stacked in the printed circuit board **310**, or printed on surface of the printed circuit board **310**.

Further, the printed circuit board **310** on exterior surface **3012** of the heat pipe **301** can be replaced with an insulation layer, such as an oxide or ceramic material to get the same insulation function. Then, forming the driving circuit inside or on surface of the insulation layer.

The axle **300** passes the central hole **212** and extrudes into the lampshade **210**. Each heat pipe **301** passes the central hole **212** into the lampshade **210**, and being defined with a heat receiving portion **302** and a heat dissipation portion **303**. As shown in FIG. 14, a rod **320** is inserted into the axle **300** for improving the stiffness of the axle **300**.

The LED chips **230** are mounted on the exterior surface **3012** of the heat pipes **301** and the end plate **330**. The LED chips **230** can be of monochromic light or polychromatic light. When using LED chips **230** of different colors, the different color LED chips **230** (for example of red, blue and green lights) are interposed so that the adjacent LED chips **230** can be controlled to provide different colors of light for different light effects of the LED lamp. The arrangement of the LED chips can be tight or dispersed.

The heat generated by the LED chips **230** is transferred from the heat receiving portion **302** to the heat dissipating portion **303** by means of thermal conduction of each heat pipe **301**. The heat transferred to the heat dissipation portion **242** is then dissipated by natural convection or an additional cooling fan **260**. It solves the problem of heat accumulation in the exterior surface **3012** of the heat pipe **301**.

The invention being thus described, it will be obvious that the same may be varied in many ways. Such variations are not to be regarded as a departure from the spirit and scope of the invention, and all such modifications as would be obvious to one skilled in the art are intended to be included within the scope of the following claims.

What is claimed is:

1. An LED lamp, comprising:

a lampshade having a concave surface, at least a hole and an opening said hole being formed on said lampshade;
an axle including a plurality of heat pipes, each one of said heat pipes having a heat receiving portion being coupled to said lampshade and a heat dissipating portion being disposed outside of said lampshade; and

a plurality of LED chips, mounted on surface of said heat receiving portion of said heat pipes;

wherein said plurality of LED chips and said heat pipes are arranged with respect to each other so that heat generated by said LED chips is transferred by said heat pipes from said heat receiving portion to said heat dissipating portion.

2. The LED lamp according to claim 1, wherein surface of said LED chips are covered with a transparent material for preventing said LED chips from reaction with air.

7

3. The LED lamp according to claim 2, wherein said transparent material is chosen from one of epoxy and silicone.

4. The LED lamp according to claim 1, further comprising a transparent plate mounted on said opening of said lampshade for preventing foreign objects entering said lampshade.

5. The LED lamp according to claim 4, wherein a space enclosed by said transparent plate and said lampshade is filled with a transparent material for preventing said LED chips from reaction with air.

6. The LED lamp according to claim 5, wherein said transparent material is chosen from one of nitrogen and inert gas.

7. The LED lamp according to claim 5, wherein said transparent material is chosen from one of epoxy and silicone.

8. The LED lamp according to claim 4, wherein a space enclosed by said transparent plate and said lampshade is vacuumed for preventing said LED chips from reaction with air.

9. The LED lamp according to claim 1, wherein an end of said axle is covered with an end plate for mounting LED chips.

10. The LED lamp according to claim 1, wherein each heat pipe has a trapezoid section for forming said axle with a polygon section.

11. The LED lamp according to claim 1, wherein each exterior surface of said heat pipe is covered by a printed circuit board.

12. The LED lamp according to claim 1, further comprising an electrically insulation layer covering exterior surface of said heat pipes.

13. The LED lamp according to claim 1, wherein said LED chips are bare chips.

14. The LED lamp according to claim 1, wherein said LED chips emit light of different colors or the same color.

8

15. The LED lamp according to claim 1, wherein said axle further comprises a rod for enhancing stiffness.

16. The LED lamp according to claim 1, further comprising at least a radiation fin mounted on said heat dissipating portion of said axle.

17. The LED lamp according to claim 1, wherein said heat pipes pass through said hole into said lampshade, extend across both sides of said lampshade and is defined with said heat receiving portion and said heat dissipating portion.

18. The LED lamp according to claim 1, wherein said heat receiving portion is disposed inside of said lampshade.

19. *An LED lamp, comprising:*

a lampshade having a reflective surface and a hole formed therein;

an axle extending through the hole and including one or more heat transfer members, wherein each one of the heat transfer members has a heat receiving portion coupled to the lampshade and a heat dissipating portion located outside of the lampshade; and

a plurality of LED chips mounted on the heat receiving portions of the one or more heat transfer members;

wherein the plurality of LED chips and the one or more heat transfer members are arranged with respect to each other such that heat, generated by the LED chips is transferred by the one or more heat transfer members from the heat receiving portions to the heat dissipating portions.

20. *The LED lamp of claim 19, wherein the reflective surface has a concave-shaped sectional side profile.*

21. *The LED lamp of claim 19, wherein the reflective surface has a pyramid-shaped sectional side profile.*

22. *The LED lamp of claim 19, wherein the one or more heat transfer members comprises one or more heat pipes.*

* * * * *

UNITED STATES PATENT AND TRADEMARK OFFICE
CERTIFICATE OF CORRECTION

PATENT NO. : RE43,626 E
APPLICATION NO. : 12/859141
DATED : September 4, 2012
INVENTOR(S) : Tain et al.

Page 1 of 1

It is certified that error appears in the above-identified patent and that said Letters Patent is hereby corrected as shown below:

In Column 6, Line 53, in Claim 1, delete “opening” and insert -- opening, --, therefor.

Signed and Sealed this
Twelfth Day of February, 2013



Teresa Stanek Rea
Acting Director of the United States Patent and Trademark Office