



US00RE43526E

(19) **United States**
(12) **Reissued Patent**
Morrison et al.

(10) **Patent Number:** **US RE43,526 E**
(45) **Date of Reissued Patent:** **Jul. 17, 2012**

(54) **ROD INTRODUCTION APPARATUS**
(75) Inventors: **Matthew M. Morrison**, Cordova, TN (US); **Eric A. Loveless**, Jacksonville, FL (US); **David L. Brumfield**, Southaven, MS (US); **B. Thomas Barker**, Memphis, TN (US); **Catalina J. Carroll**, Memphis, TN (US); **David Miller**, Eads, TN (US); **Dominique Petit**, Sur Mer (FR)
(73) Assignee: **Warsaw Orthopedic, Inc.**, Warsaw, IN (US)

5,314,431 A * 5/1994 Graziano 606/101
5,330,472 A 7/1994 Metz-Stavenhagen
5,364,397 A 11/1994 Hayes et al.
5,389,099 A * 2/1995 Hartmeister et al. 606/86 A
5,392,978 A 2/1995 Velez et al.
5,423,855 A * 6/1995 Marianne 606/208
5,449,361 A 9/1995 Preissman
5,458,608 A 10/1995 Wortrich
5,466,243 A 11/1995 Schmieding et al.
5,588,580 A 12/1996 Paul et al.
5,616,143 A 4/1997 Schlapfer et al.
5,720,751 A * 2/1998 Jackson 606/86 R

(Continued)

(21) Appl. No.: **12/052,465**
(22) Filed: **Mar. 20, 2008**

FOREIGN PATENT DOCUMENTS

DE 4238339 5/1994

(Continued)

Related U.S. Patent Documents

Reissue of:

(64) Patent No.: **5,910,141**
Issued: **Jun. 8, 1999**
Appl. No.: **08/798,092**
Filed: **Feb. 12, 1997**

OTHER PUBLICATIONS

Compact CD Low Back Surgeon's Documentation, Sofamor Spine Division, pp. 60-61, 78-79. Date unknown.*

(Continued)

(51) **Int. Cl.**
A61B 17/56 (2006.01)
(52) **U.S. Cl.** **606/86 A**
(58) **Field of Classification Search** 606/246,
606/264, 265, 278, 279, 86 R, 99, 100, 101,
606/86 A, 300, 305
See application file for complete search history.

Primary Examiner — Eduardo C Robert
Assistant Examiner — David Comstock

(57) **ABSTRACT**

An introduction apparatus for approximating a longitudinal member and an implant to permit fixation therebetween. The introduction apparatus having a gripping nose for securely engaging an implant, a lateral approximation mechanism for laterally aligning an implant and an offset longitudinal member, and a reduction mechanism for reducing the vertical distance between the implant and the longitudinal member. The introduction apparatus is provide with a gripping nose actuated by axial movement of a clamping shaft in an outer sleeve. The clamping shaft further includes an axial cannula for passage of a fastener to the implant.

(56) **References Cited**

U.S. PATENT DOCUMENTS

3,604,487 A 9/1971 Gilbert
3,844,291 A 10/1974 Moen
4,411,259 A 10/1983 Drummond
5,020,519 A * 6/1991 Hayes et al. 606/237
5,113,685 A * 5/1992 Asher et al. 72/458
5,209,755 A 5/1993 Abrahan et al.
5,308,357 A 5/1994 Lichtman

39 Claims, 10 Drawing Sheets

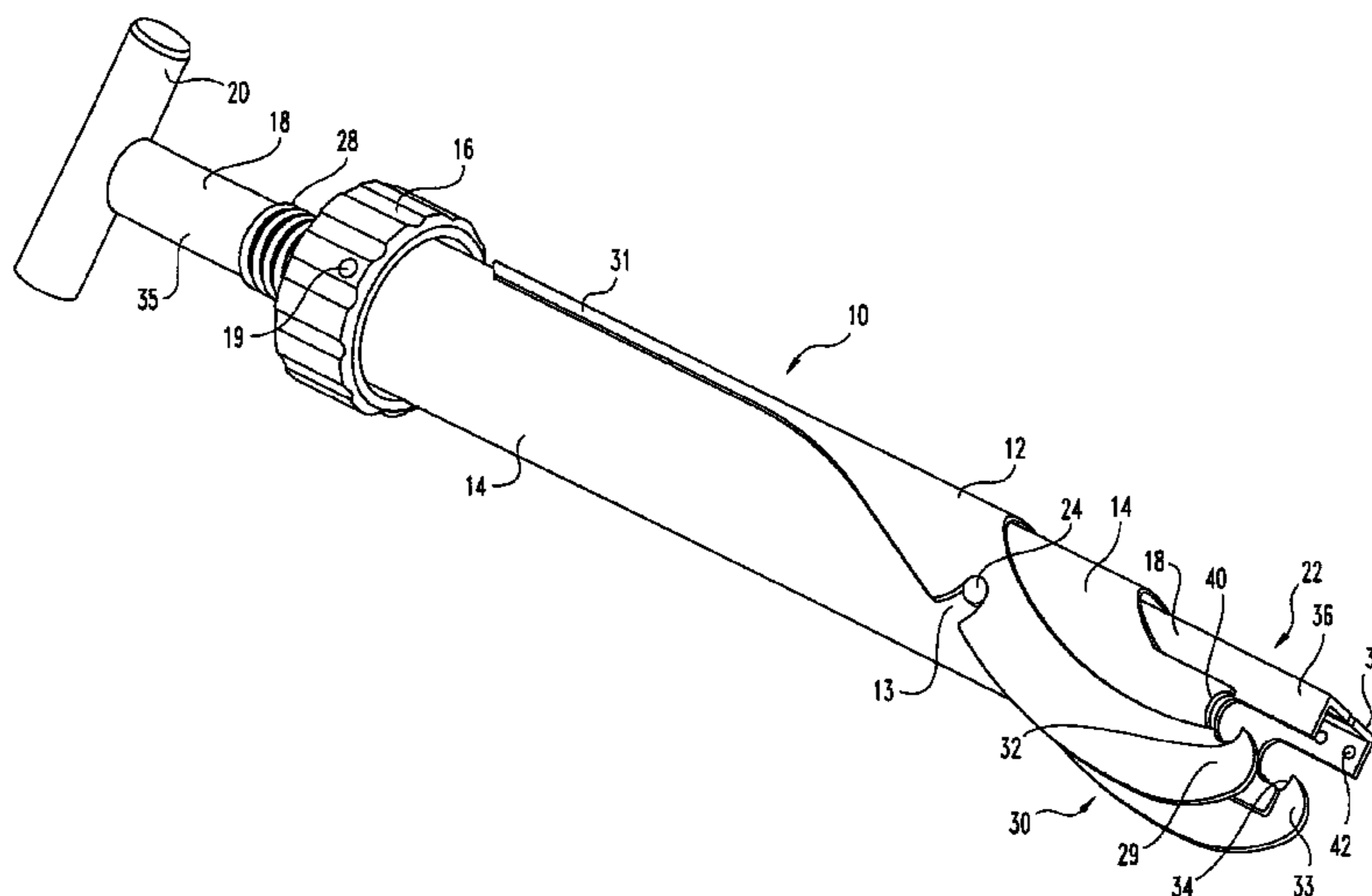

US RE43,526 E

Page 2

U.S. PATENT DOCUMENTS

5,782,830 A 7/1998 Farris
5,782,831 A 7/1998 Sherman et al.
5,810,878 A 9/1998 Burel et al.
5,855,311 A 1/1999 Hamblin et al.
5,899,901 A 5/1999 Middleton
5,944,720 A 8/1999 Lipton
6,036,692 A 3/2000 Burel et al.
6,042,582 A 3/2000 Ray
6,063,088 A 5/2000 Winslow
6,261,296 B1 7/2001 Aebi et al.
6,440,133 B1 8/2002 Beale et al.
6,790,209 B2 9/2004 Beale et al.
6,830,570 B1 12/2004 Frey et al.
7,156,849 B2 1/2007 Dunbar et al.
7,470,279 B2 12/2008 Jackson
7,611,517 B2 11/2009 Lim
7,625,376 B2 12/2009 Brumfield et al.
2004/0267275 A1 12/2004 Cournoyer et al.
2005/0192570 A1 9/2005 Jackson
2005/0192579 A1 9/2005 Jackson
2005/0228400 A1 10/2005 Chao et al.
2006/0036244 A1 2/2006 Spitler et al.
2006/0074418 A1 4/2006 Jackson
2006/0111712 A1 5/2006 Jackson
2006/0173454 A1 8/2006 Spitler et al.
2007/0270867 A1 11/2007 Miller et al.
2007/0270868 A1 11/2007 Dewey
2007/0276379 A1 11/2007 Miller et al.
2008/0077139 A1 3/2008 Landry et al.
2008/0091213 A1 4/2008 Jackson
2008/0234678 A1 9/2008 Gutierrez et al.
2008/0234765 A1 9/2008 Frasier et al.

FOREIGN PATENT DOCUMENTS

RU 995769 * 2/1983 606/101

OTHER PUBLICATIONS

The RSRH Minicordscrew, pp. 50-51, ch. 2. Date unknown.*
Cortel-Dubousset Instrumentation (1 page). Date unknown.*
Universal Spinal System Rod Introduction Pliers by Synthes Spine (13 pages). Date unknown.*
Sofamor, "Introducteur—Contreur De Tige" (schematic drawings), Jan. 1, 1994.
Laufer and Bowe, CD Horizon Spinal System, Surgical Technique, 1996, Sofamor Danek.
TSRH-3D Vertebral Body Reduction Instrumentation, 2001, Medtronic Sofamor Danek.
Shufflebarger et al., Taking Spinal Instrumentation to a New Dimension, 1995.
Moss® Miami 3-Dimensional Instrumentation Product Catalogue, 1995, Depuy Motech, Inc.
Pediatric Isola® Spinal System, Ordering Information for Implants and Instruments, 1998, AcroMed Corporation.
Orthopedic Sourcebook, Instruments for Surgeons, Section K, 1999, Medic.
Z Spinal Instrumentation, Section D, 1987, Zimmer, Inc.
Sofamor Rod Reducer (1994).
Universal Spinal System Rod Introduction Pliers by Synthes Spine (13 Pages).
Pages 50-51, Chapter 2, The TSRH Minicordscrew.

* cited by examiner

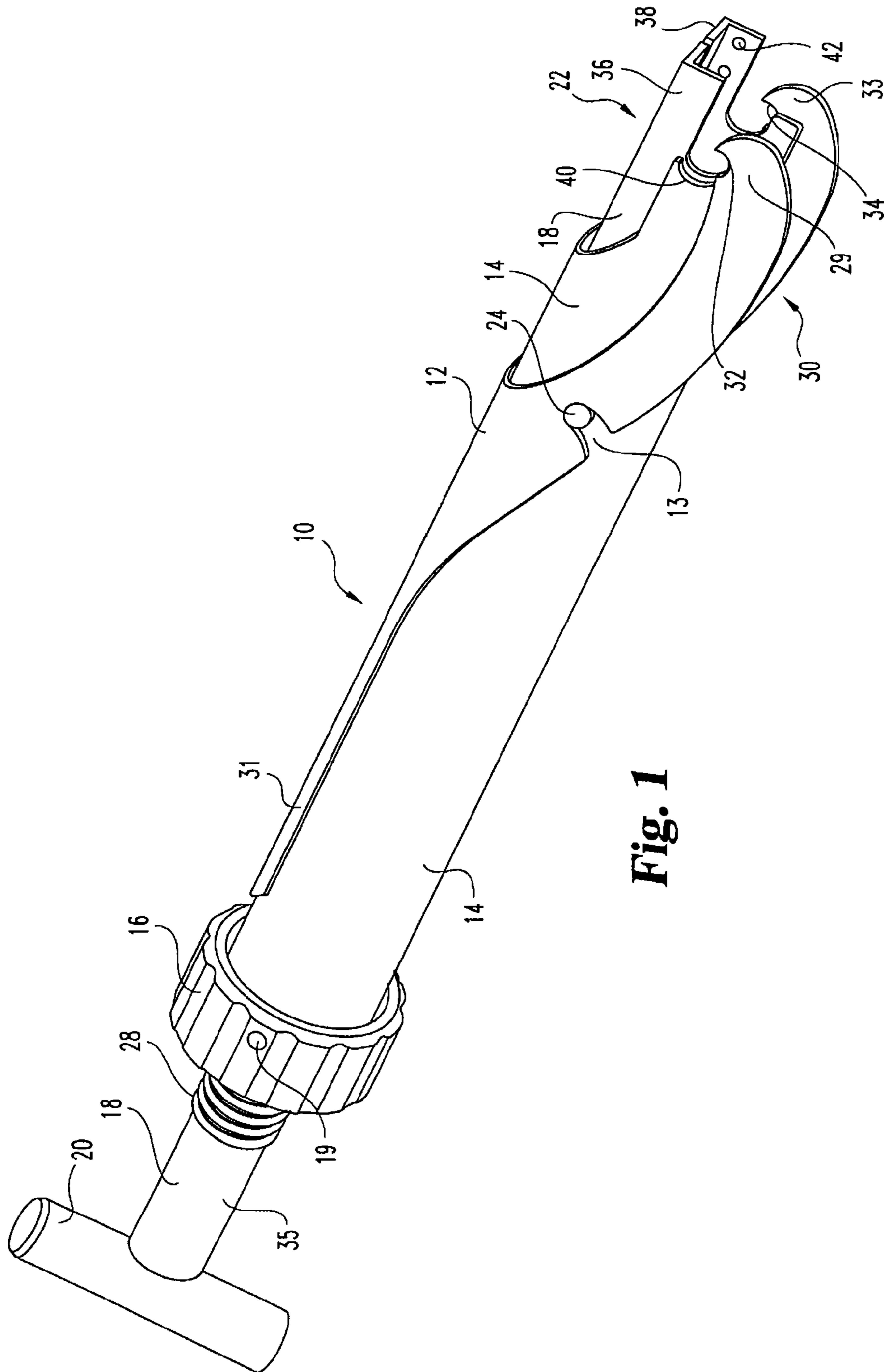

Fig. 1

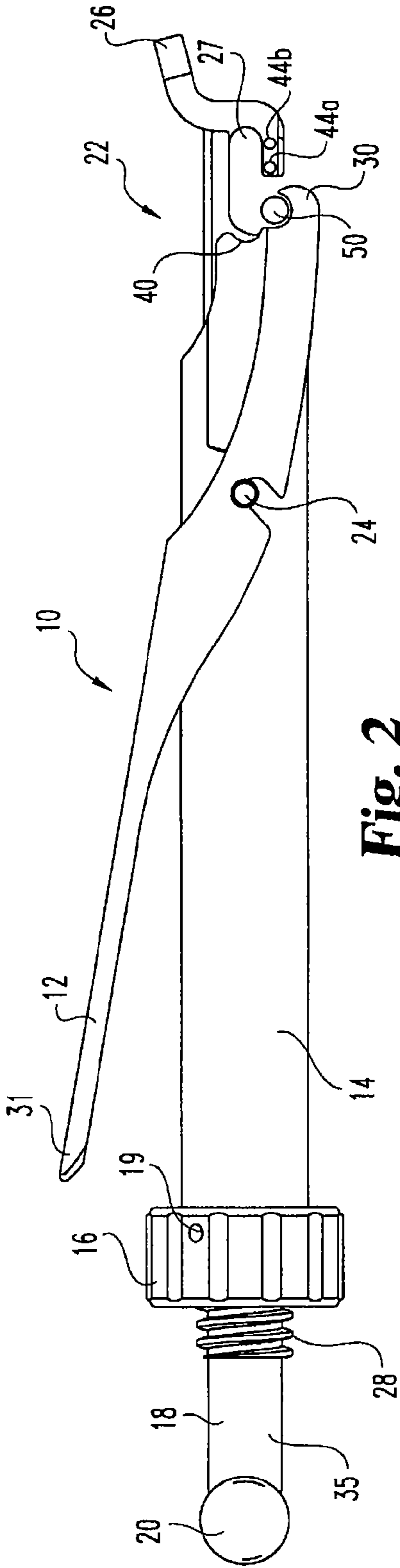

Fig. 2

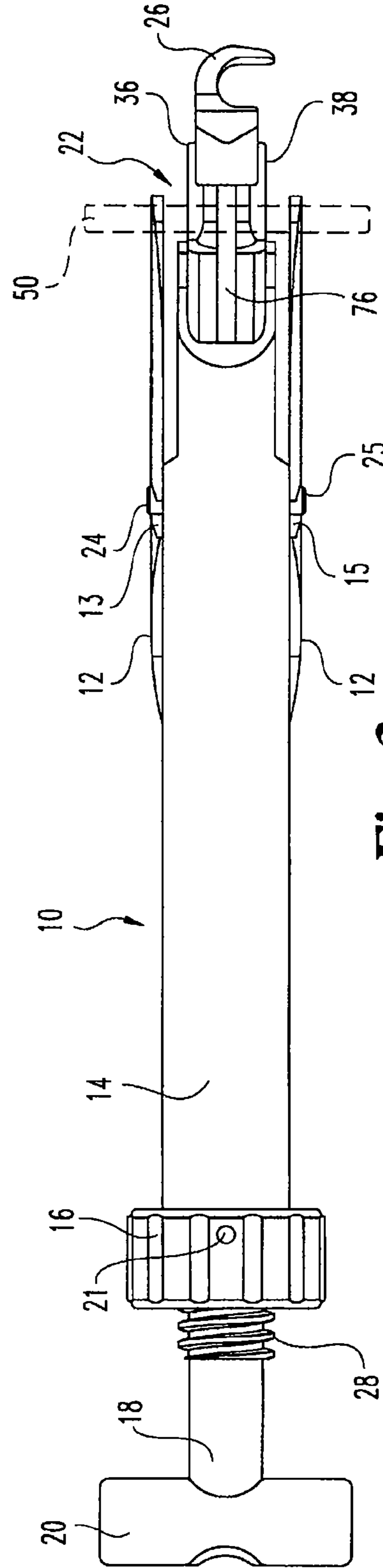

Fig. 3

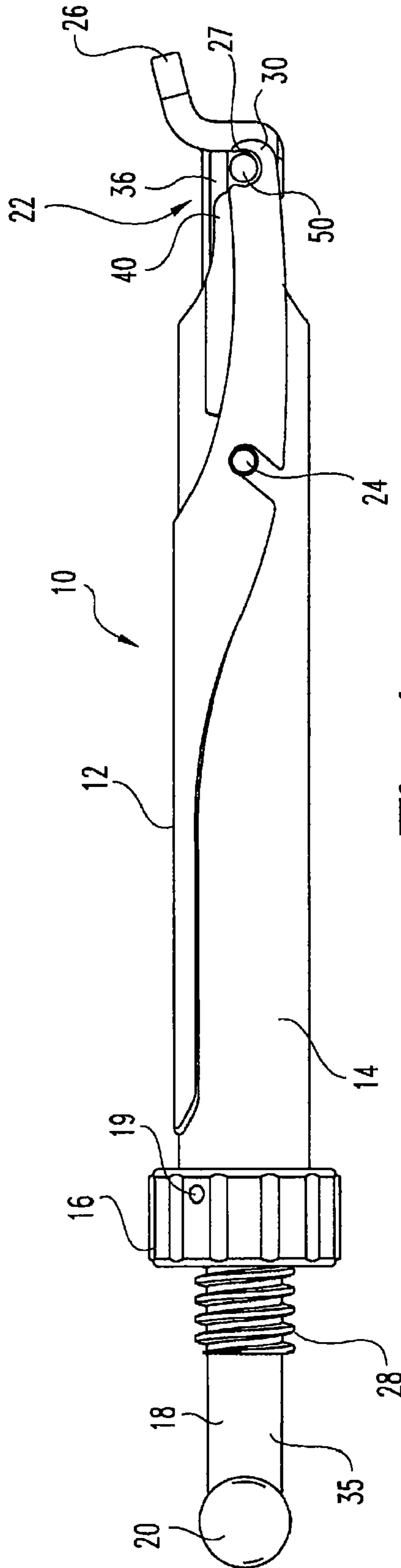

Fig. 4

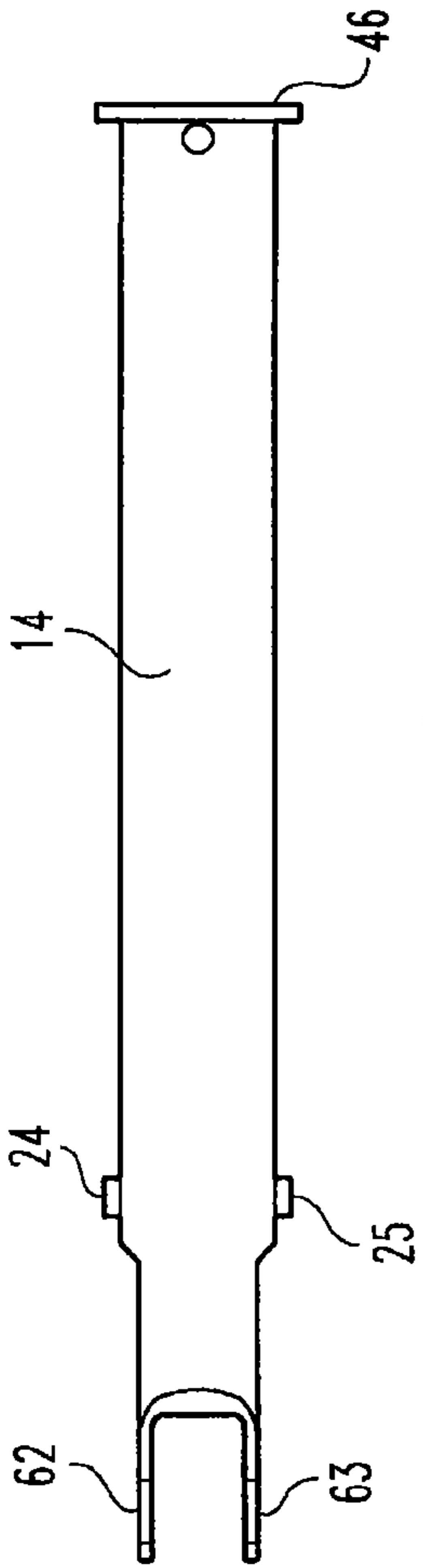

Fig. 5

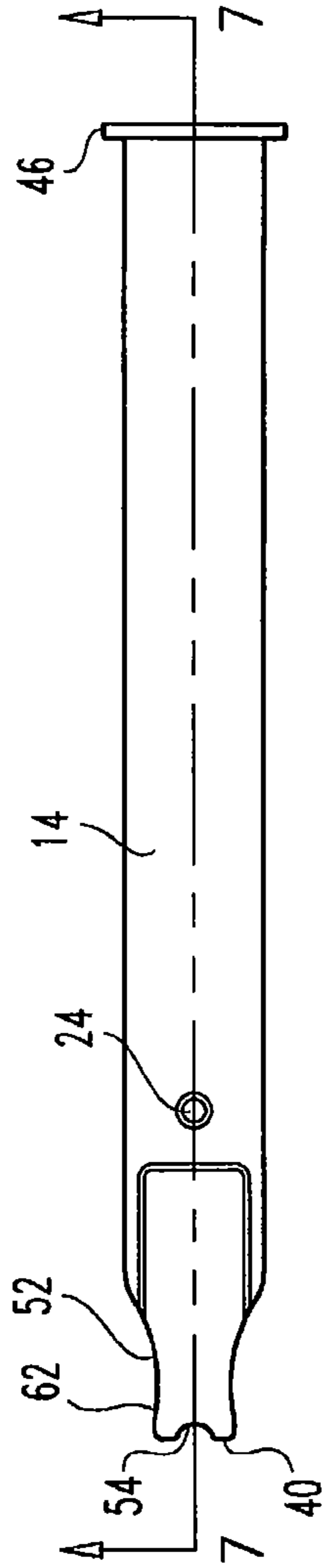

Fig. 6

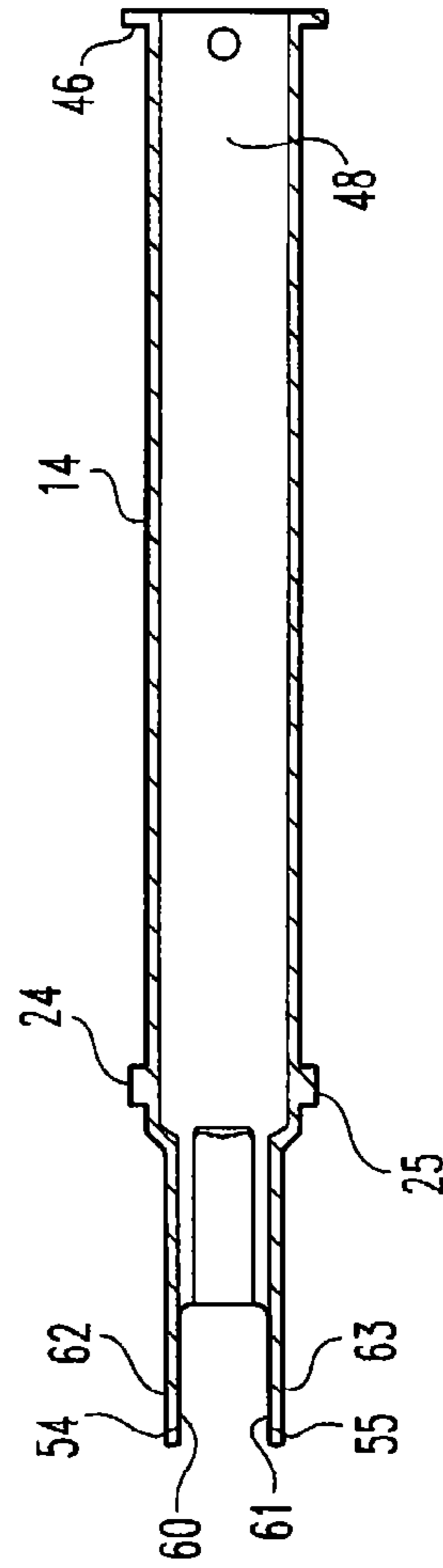

Fig. 7

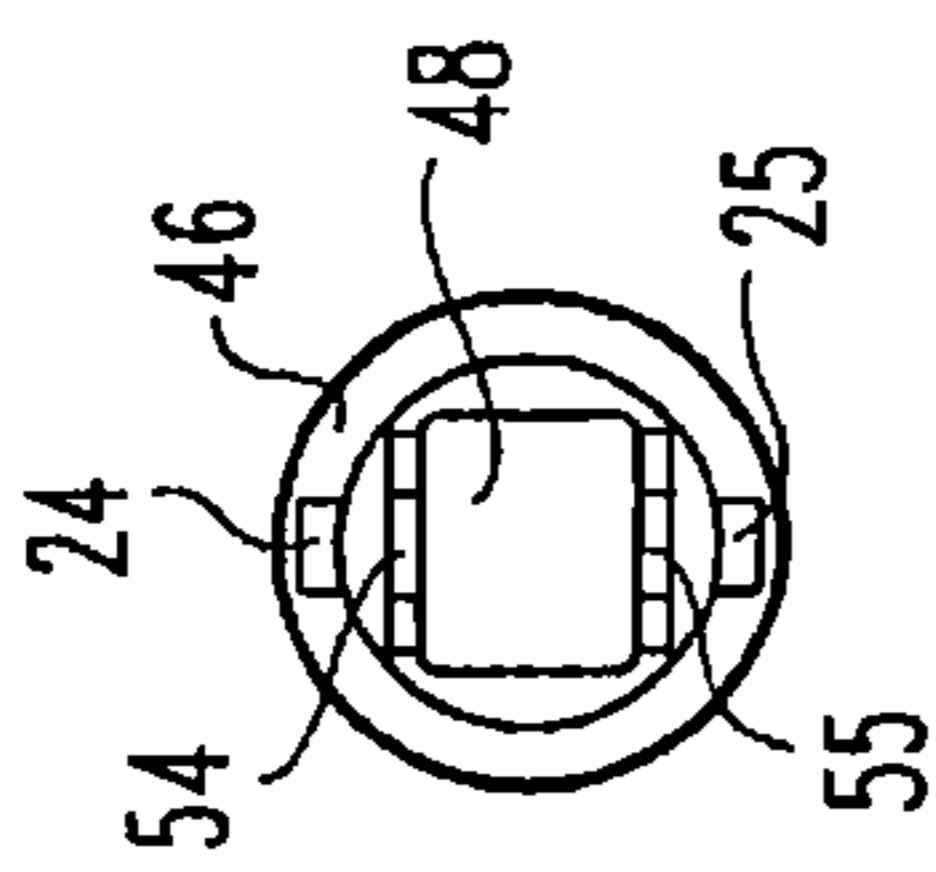

Fig. 8

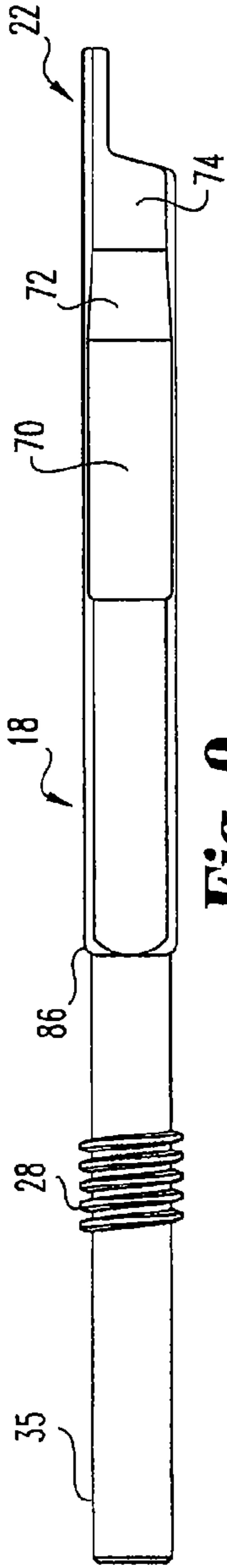

Fig. 9

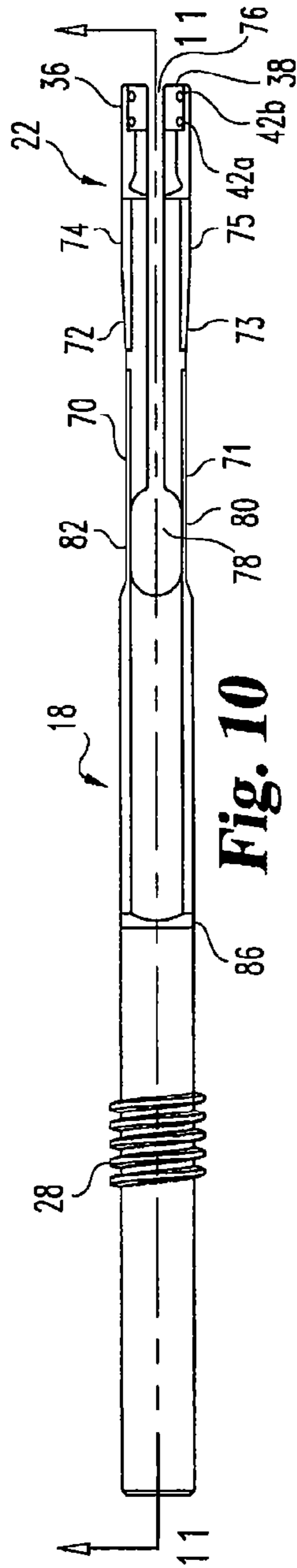

Fig. 10

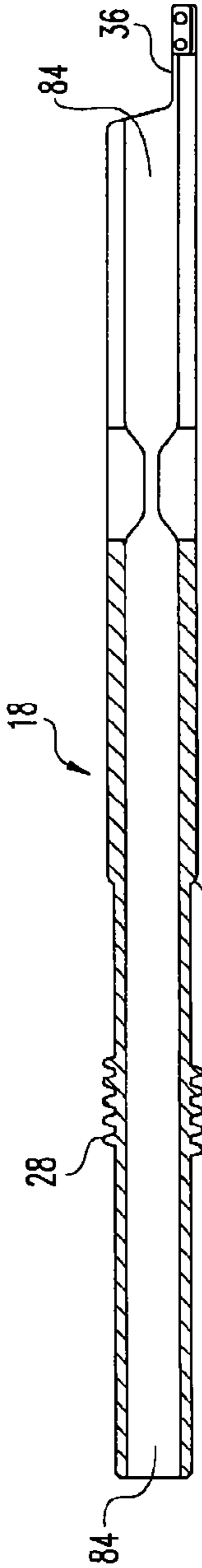

Fig. 11a

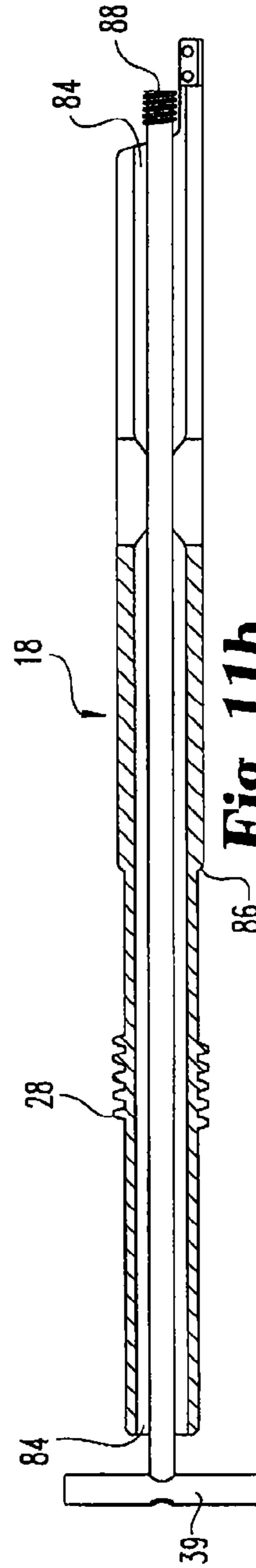

Fig. 11b

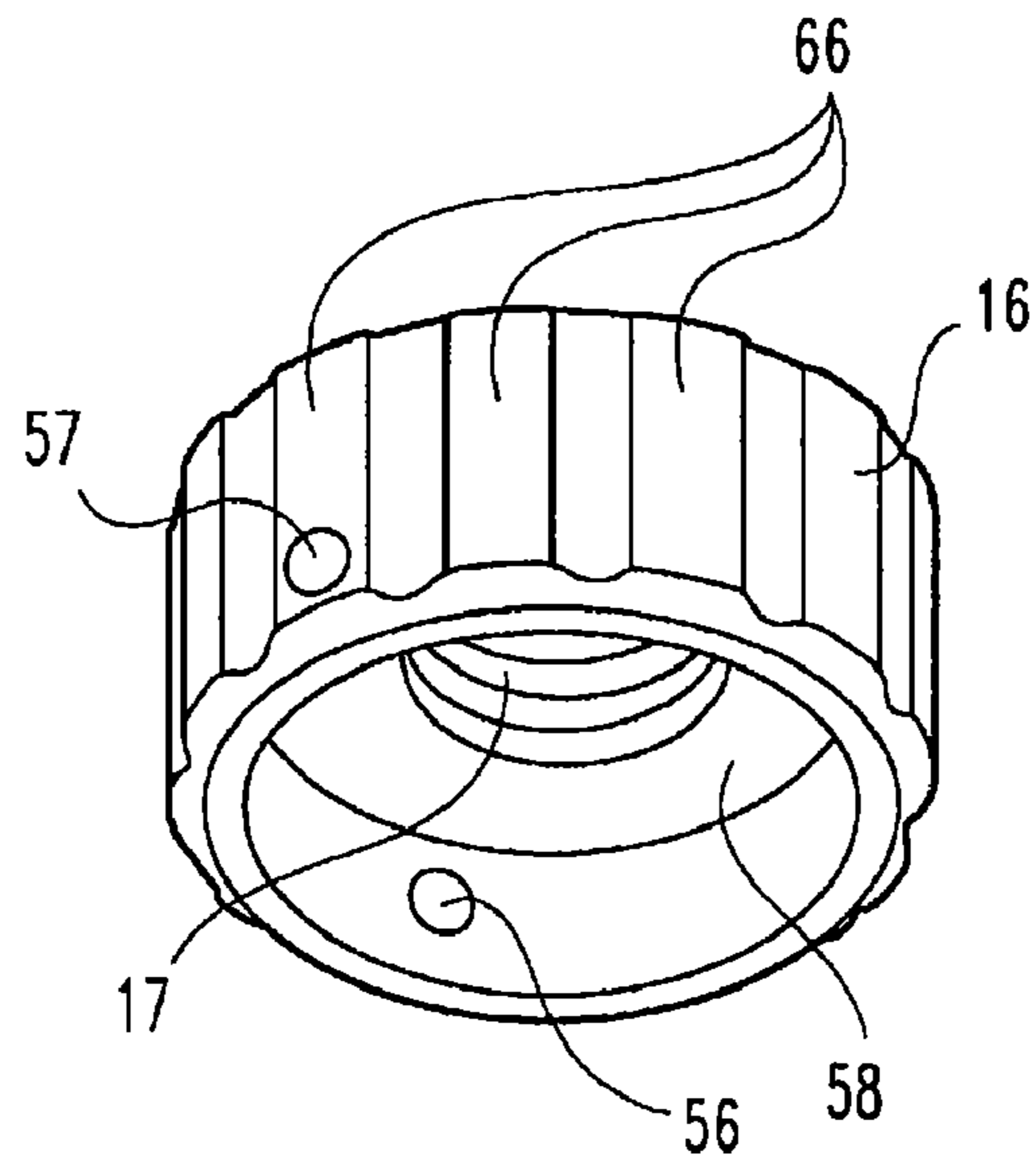

Fig. 12

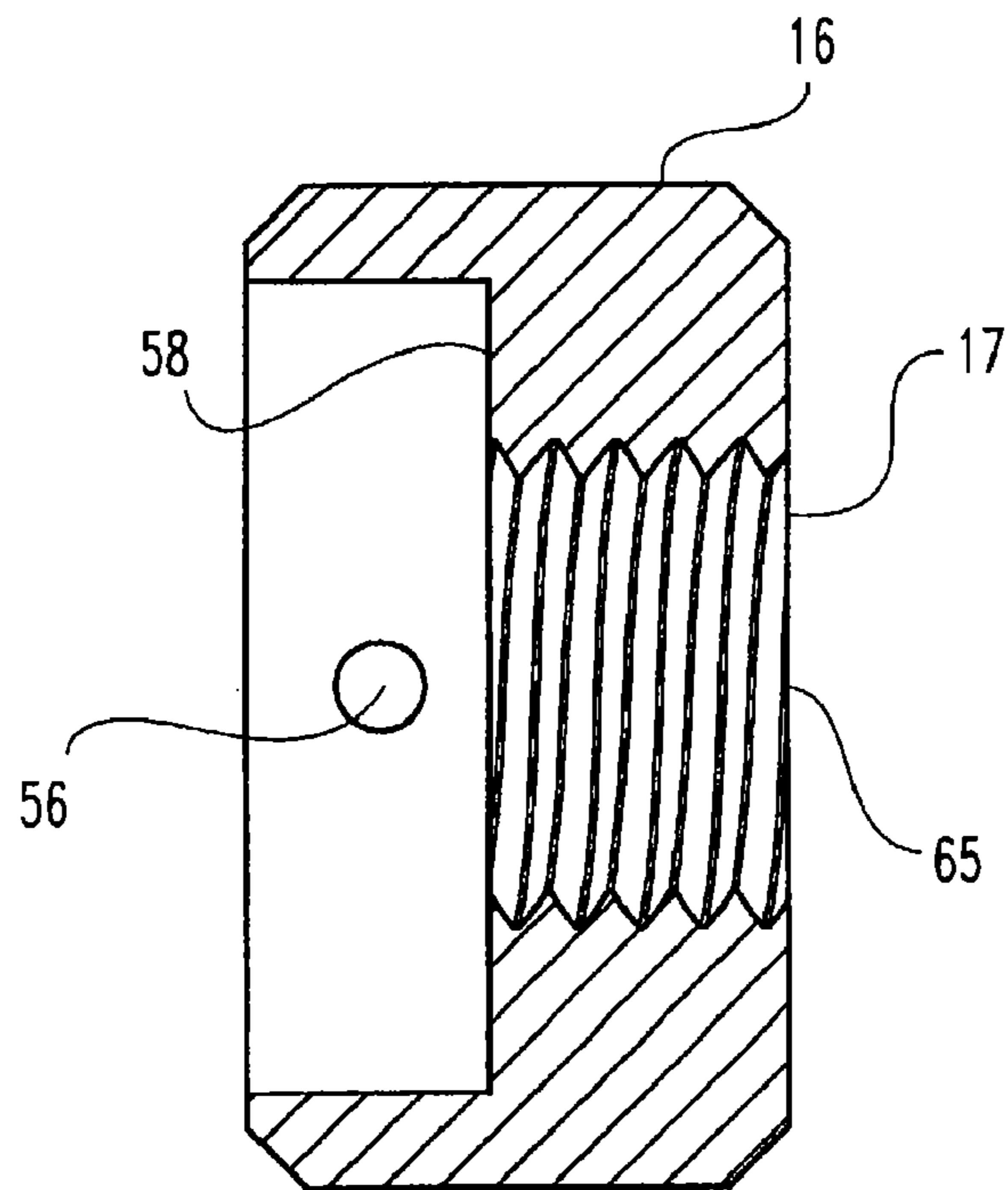

Fig. 13

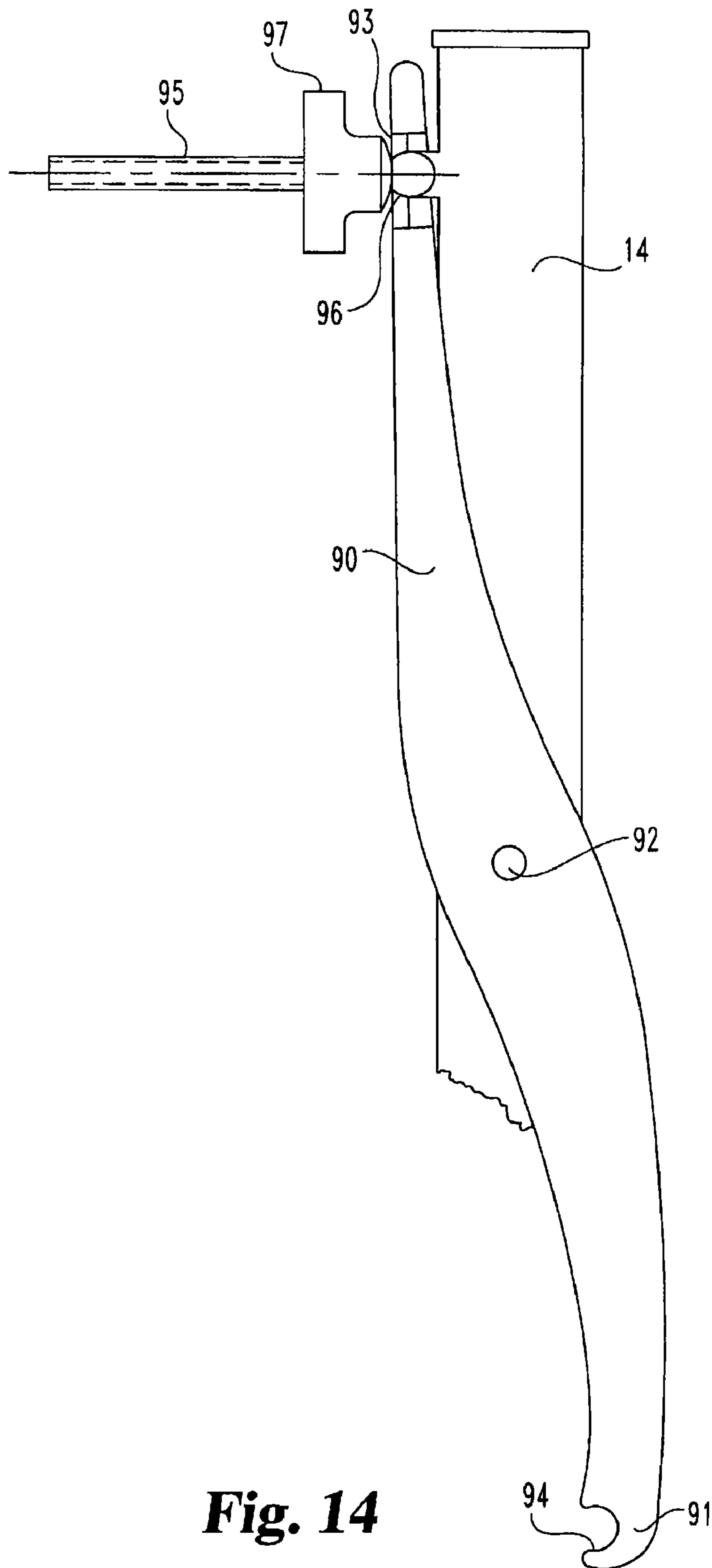

Fig. 14

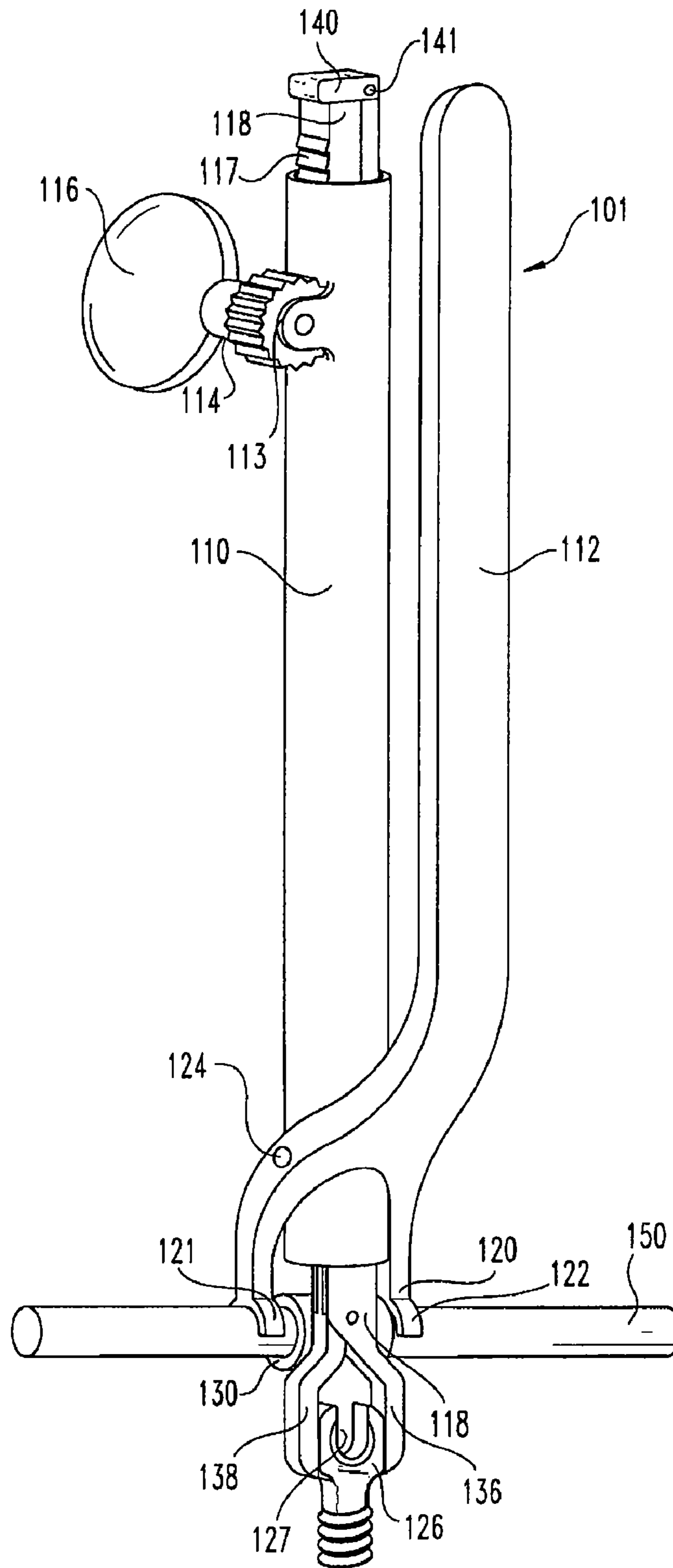

Fig. 15

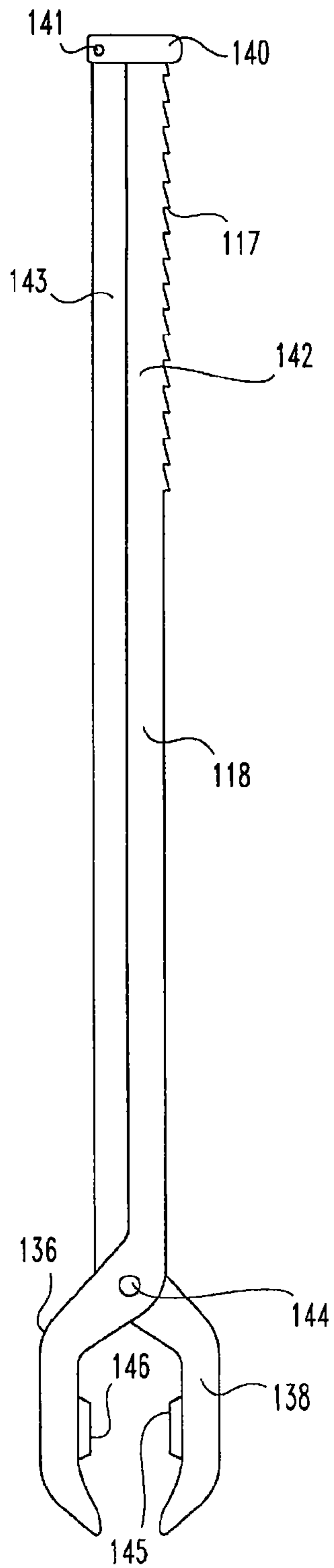

Fig. 16

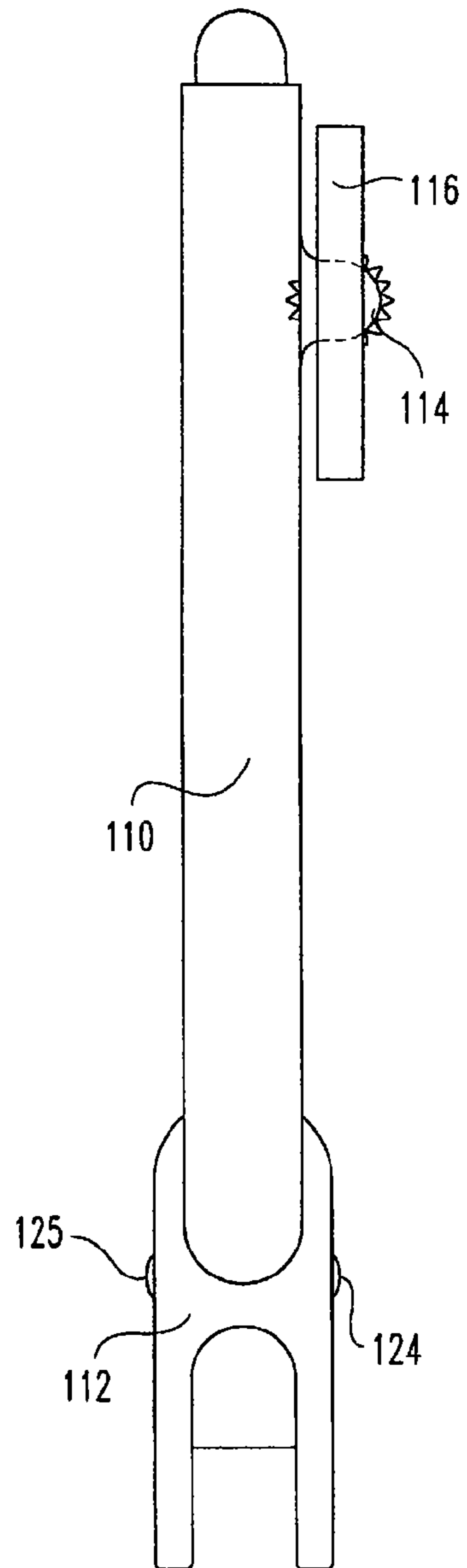

Fig. 17

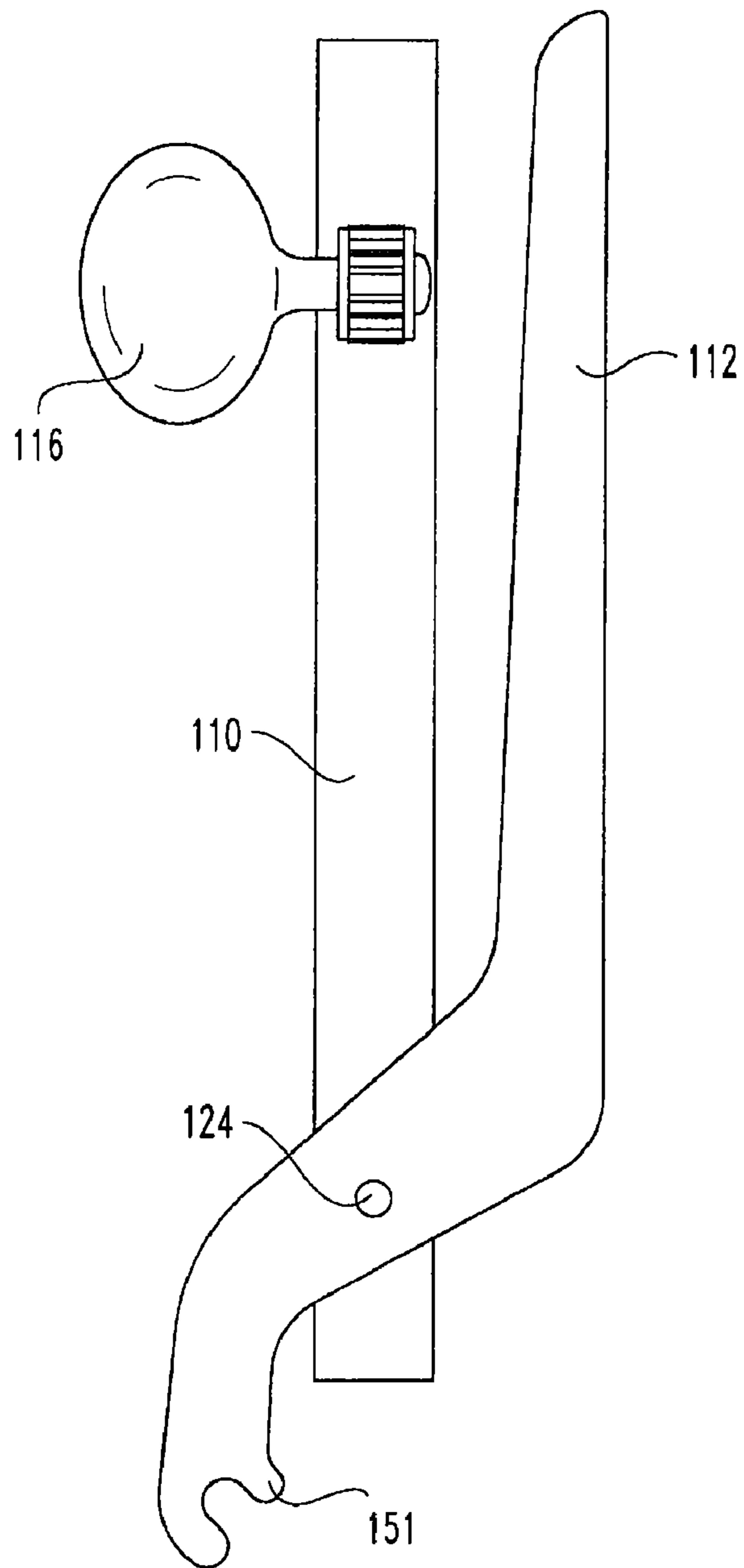

Fig. 18

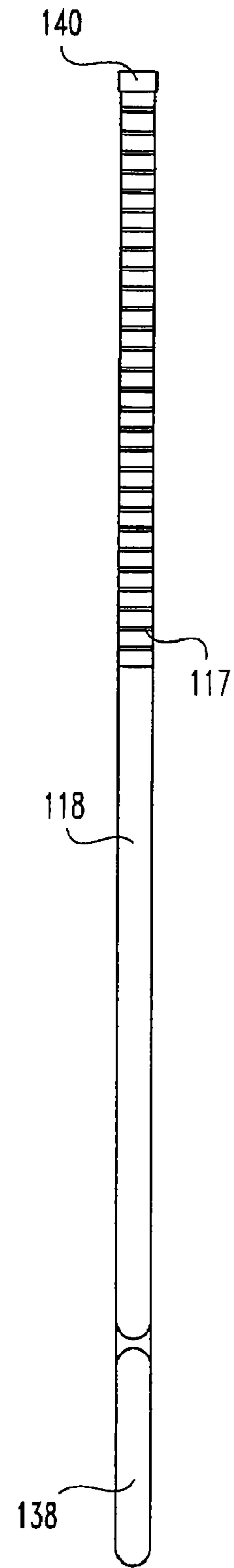

Fig. 19

ROD INTRODUCTION APPARATUS

Matter enclosed in heavy brackets [] appears in the original patent but forms no part of this reissue specification; matter printed in italics indicates the additions made by reissue.

This application is a reissue of U.S. Pat. No. 5,910,141, issued on Jun. 8, 1999, which is hereby incorporated by reference, as if fully set forth herein. U.S. Pat. No. 5,910,141 matured from U.S. application Ser. No. 08/798,092, filed Feb. 12, 1997.

BACKGROUND OF THE INVENTION

1. Description of the Prior Art

The present invention relates generally to instruments used to manipulate orthopedic implants. More particularly, the present invention relates to the manipulation of bone anchoring elements positioned in the spine and longitudinal members interconnecting those elements. While the present invention is particularly useful in spinal surgery, it may find use in other areas of medicine as well.

In many applications, particularly those relating to spinal correction techniques, it is desirable to place a series of implants in a patient's spine prior to inserting a longitudinal member (a rod or a plate) along the spine to interconnect the previously placed implants. On occasion, implants may be vertically spaced from the rod or plate and require a mechanical mechanism to bring the rod or plate into contact with the implant. In the instance of a plate, often the implant is a double threaded bolt with a series of bone screw threads anchoring into the bone and a machine threaded post extending through an opening in the plate. A machine threaded nut slightly larger than the opening in the plate may then be threaded onto the threaded post and tightened to bring the implant closer to the plate. For rod systems, a similar arrangement can be utilized whereby the threaded post of the implant extends through a connector attached to the rod. In these systems a nut is used to draw the implant closer to the connector by progressively threading the nut onto the post of the bone bolt.

Alternatively, it is known to provide a rod introducer mechanism that forces the rod and an implant towards each other. In some cases, the threaded post of a bolt type bone anchor is not long enough to extend through a connector attached to the rod. In this situation a mechanism is used to grasp the bolt and pull it towards the connector until the threaded post extends through an opening in the connector. A threaded nut may then be used to complete the connection to the connector.

In other cases the implant, either a bone screw or spinal hook, includes an open channel to receive the rod. A plug or set screw can be used to close the channel and lock the rod to the implant. In certain surgical techniques a rod is anchored at both ends by at least one implant, resulting in the rod being suspended above a second implant. A mechanism is then required to urge the second implant and rod together to permit connection of the implant to the rod and more particularly to seat the rod within the open channel of the implant. One such instrument marketed by Sofamor Danek Group as part of the Compact CD™ system, is an introducer lever C-6903 which resembles a fork with a pair of offset tines. The tines of this device extend over the vertically spaced rod and under either side of an enlarged portion of the implant. Once in place, the

fork handle is moved toward the rod thereby forcing the rod and implant together. One problem with this arrangement is that the fork tines must pass between the implant and the bone, which in many cases may be difficult and may result in damage to the bone. Moreover, the connection between the fork tines and the implant is not a secure engagement and may result in the rod introducer slipping during the procedure of forcing the rod into the implant.

Other types of rod introduction devices have overcome the problems associated with the simple fork device by first achieving a secure attachment to the implant with articulated forceps or the like. Various instruments for gripping and handling implants are commonly known. One such instrument has a pair of articulating branches defining a gripping nose opposite a pair of handles. While many varieties of these forceps exist to accomplish various functions during surgery, some are adapted specifically to securely hold an implant, and in particular, a spinal osteosynthesis implant. The gripping nose of one such configuration utilizes a pair of inwardly facing cylindrical projections disposed at the distal end of the gripping nose. The cylindrical projections are adapted to engage corresponding recesses on an implant, thereby providing a secure grip. Because of the small size of many spinal implants and the accompanying difficulty gaining a secure grip with only manual pressure, such forceps are often utilized in the manipulation and placement of the implants.

In addition to providing a nose for gripping implants, many forceps also provide a locking mechanism to hold the forceps in the gripping position once the implant is gripped. A common example is the provision of one half of a ratchet rack on one articulating branch aligned to engage a second half of the ratchet rack on the other articulating branch. Upon movement of the branches towards one another, the separate halves of the ratchet rack come into engagement thereby preventing separation of the articulating branches. As is common with such arrangements, the articulating branches have sufficient flexibility that they may be flexed with respect to one another, thereby disengaging the ratchet racks.

An alternative forcep locking mechanism is disclosed in U.S. Pat. No. 5,423,855 owned by the Sofamor SNC subsidiary of Sofamor Danek Group. This patent shows forceps having an implant gripping nose as previously discussed. In this configuration, the articulating branches are held in the closed position by a spring biased cap disposed on the end of the branches opposite the gripping nose.

In prior systems, once a secure engagement has been accomplished between the forceps and the implant, a separate apparatus is attached between the forceps and the rod. In one such mechanism marketed by Sofamor Danek Group as the TSRH™ mini-corkscrew, a threaded rod is threadedly coupled at one end to the forceps and engages the rod at the opposite end. Rotation of the threaded rod urges the rod and implant towards each other. In another mechanism marketed by Sofamor Danek Group as an articulated rod pusher C-6211 for use with the Compact CD™ system, forceps grip the implant and a pivoting two piece rod pusher lever is used to urge the rod and implant towards one another. In this device, a lower end of the first member of the rod pusher engages the rod and the upper end of the first member is pivotally attached to the second member of the rod pusher lever. The lower end of a second member engages the forceps while the upper end of the second member is rotated to force the rod and implant towards each other.

U.S. Patent 5,020,519 to Hayes et al. discloses a single mechanism which both grips the rod and has a threaded mechanism to accomplish vertical reduction of the rod into the implant. As this reference discloses, the mechanism must

first be attached to the implant and then the rod threaded through the opening between the clamping jaws. This unnecessarily creates a complication for the surgeon, i.e. maintaining both the reduction mechanism and the hook in the desired position while attempting to thread the rod through various implants and the opening in the reduction apparatus. Moreover, once the rod has been reduced into the implant opening, the reduction apparatus interferes with visualizing the implant and rod connection, and with placement of a fastener to hold the rod in the implant.

In addition to the surgical condition where the rod is suspended above the implant, the rod may be laterally offset with respect to the implant. Moreover, in some applications the implant may have an implant opening for receiving the rod which opens to the side, thereby requiring the rod to be laterally introduced into the implant. In these instances, it is often desirable to have mechanical assistance in bringing the rod and implant together to permit securing the rod within the implant. One such device marketed by Synthes Spine as the Universal Spinal System Rod Introduction Pliers is utilized to urge a laterally offset rod into a side opening implant. The Rod Introduction Pliers are used in conjunction with a Hook or Screw Holder device threadedly engaging the implant. One branch of the pliers consists of a barrel while the opposing branch defines a rod engaging surface. In operation, this barrel is placed over the Hook or Screw Hold device and the opposing branch of the pliers engages the offset rod and upon actuation of the plier handles the rod is urged into the implant opening. While this system provides a means to reduce the lateral displacement of the rod, it does not permit the user to additionally reduce any vertical displacement between the rod and the implant. Rather, the barrel of the rod introduction pliers apparently slides freely up and down the hook holder.

In addition to having a need, in some surgical situations, to both laterally approximate the rod to the implant and to vertically reduce the rod into the implant, there is a need to deliver a fastening member to the implant while the rod is securely held in place by the rod reduction apparatus. In some systems, the components required to accomplish reduction are offset with respect to the implant, thereby providing access to the implant to facilitate placement of the fastener once the rod is inserted into the implant. Use of offset instruments to apply force to the rod and implant may impart rotational forces to the implant tending to displace the implant from the desired location. Moreover, in most applications the fastening elements must be relatively small to prevent unnecessary protrusion from the implant. While this is desirable after placement, the small size of the fastener makes handling these items difficult. The difficulty of handling the small fasteners is increased when it is required to place them in the implant that is partially obscured by the rod introduction device. One approach to solving this problem is taken by the Universal Spine System pliers discussed above. In operation, a fastening collar is preloaded over the barrel prior to placement over the hook holder. Once the rod has been inserted into the implant the collar may be advanced over the barrel and engaged with the implant.

One disadvantage to the systems discussed above, is that none of the systems provide both a mechanism for reducing vertical rod offset and lateral rod offset from the bone anchor in a single device. Moreover, many of the systems utilize articulating clamping tips actuated by articulating handles to hold the implants and require a separate apparatus attached to the hook or screw holder to perform manipulation of the rod. It will be appreciated that the various handles extending out of the patient interfere both with vision and work space in an already limited surgical field. Therefore, it is desirable to

provide a compact implant holder adapted to perform both vertical and lateral reduction of a rod.

The present invention overcomes the problems associated with the prior art by providing a gripping mechanism and a rod introduction lever for both lateral and vertical approximation in a single convenient instrument.

SUMMARY OF THE INVENTION

One form of the present invention contemplates a multiple action insertion apparatus for engaging a longitudinal member and an implant, comprising an implant holder including a first clamping branch and a second clamping branch cooperable with the first clamping branch to hold to the implant, a reduction mechanism interconnected with the implant holder, the reduction mechanism having a distal end for engaging the longitudinal member, wherein the reduction mechanism urges the longitudinal member into vertical alignment with the implant, and a lateral approximator mechanism interconnected with the implant holder, the lateral approximator mechanism having a distal end disposed adjacent the first and second clamping branches, said distal end adapted to engage the longitudinal member, wherein said lateral approximator mechanism urges the longitudinal member into lateral alignment with the implant.

Still a further form of the present invention contemplates a multiple action insertion apparatus for engaging a longitudinal member and an implant, comprising a device for attaching to an implant having an opening for receiving a rod, a device for lateral approximation of a longitudinal member laterally offset from the implant rod opening, the device for lateral approximation interconnected with the device for attaching, and a device for vertical reduction of a longitudinal member vertically offset from the implant, the device for vertical reduction interconnected with the device for attaching, wherein the device for lateral approximation laterally aligns the longitudinal member over the implant and the device for vertical reduction vertically aligns the longitudinal member with the implant.

Another form of the invention contemplates an implant holder for holding an implant adapted to receive a fastener, comprising a device for gripping the implant, the device for gripping including a gripping end and a handle defining a longitudinal cannula having a distal end adjacent the gripping end, the cannula adapted to receive a fastener cooperable with the implant.

In another aspect, the present invention contemplates an implant holder for gripping an implant, comprising a shaft having a gripping end with a portion, the gripping end defining a first clamping branch and a cooperable second clamping branch, the first and second clamping branches tending to assume an insertion position defining a first distance between the first and second clamping branches, and the first and second clamping branches compressible into a clamping position defining a second distance between the first and second clamping branches, the first distance greater than the second distance, and a sleeve defining an interior channel, the shaft slidably received within the interior channel, the shaft moveable between a first position with the portion extending from the sleeve and a second position with the portion drawn into the sleeve, wherein movement of the shaft within the tubular sleeve from the first position to the second position controls the first and second clamping branches from the insertion position to the clamping position.

Another form of the present invention contemplates an implant holder having a rod reduction mechanism for vertically aligning a longitudinal member and an implant, com-

5

prising a device for gripping the implant, a sleeve having an axis and a distal end adapted to engage the longitudinal member, the sleeve having an axial bore sized to receive the device for gripping, the device for gripping slidably received within the axial bore, and a device for axially displacing the sleeve with respect to the device for gripping, whereby the vertical offset longitudinal member is urged into alignment with the implant.

Additionally, the invention includes a method for for interconnecting a longitudinal member and an implant adapted to engage the longitudinal member, comprising the steps of providing an introduction apparatus having an attachment mechanism with a cannula and a vertical reduction mechanism, attaching the introduction apparatus to the implant, operating the vertical reduction mechanism to force the longitudinal member into alignment with the implant, inserting a fastener through the cannula, interconnecting the fastener and the implant, wherein the longitudinal member is securely attached to the implant, and removing the introduction apparatus.

The invention includes an additional method for interconnecting a longitudinal member and an implant adapted to engage the longitudinal member, comprising the steps of providing an introduction apparatus having an attachment mechanism, a lateral approximation lever, and a vertical reduction mechanism, attaching the introduction apparatus to the implant, engaging a laterally offset longitudinal member with one end of the lateral approximator lever, rotating the lever to urge the longitudinal member into lateral alignment with the implant, operating the vertical reduction mechanism to force the longitudinal member into vertical alignment with the implant, and interconnecting the longitudinal member and the implant.

One object of the present invention is to provide an implant holder having a cannula for passage of a fastener to the implant while it is being securely held.

Another object of the present invention is to provide a simple device for gripping the implant and reducing vertical offset between an implant and a longitudinal member.

A further object of the present invention is to provide an implant holder operable in a small lateral area to clamp an implant by axial movement of the holder mechanism.

Still a further object of the present invention is to provide a multiple action insertion apparatus that is capable of gripping an implant, approximating the implant and an laterally offset longitudinal member, and reducing the vertical distance between the implant and the longitudinal member.

Another object of the present invention is to provide a multiple action insertion apparatus that is capable of gripping an implant, approximating the implant and an laterally offset longitudinal member, and reducing the vertical distance between the implant and the longitudinal member wherein the apparatus includes a cannula for insertion of a fastening member.

Related objects and advantages of the present invention will be apparent from the following description.

BRIEF DESCRIPTION OF THE DRAWINGS

FIG. 1 is a perspective view of the rod introduction apparatus according to the present invention.

FIG. 2 is a side view of the rod introduction apparatus of FIG. 1.

FIG. 3 is a bottom plan view of the rod introduction apparatus of FIG. 1.

FIG. 4 is a side view of the rod introduction apparatus of FIG. 2 with the rod seated in the implant.

6

FIG. 5 is a top view of the rod introduction sleeve.

FIG. 6 is a side view of the rod introduction sleeve.

FIG. 7 is a cross-sectional view taken along section lines 7—7.

FIG. 8 is an end view of the rod introduction sleeve looking into the rod bearing surface.

FIG. 9 is a side view of a rod introduction clamp shaft.

FIG. 10 is a bottom view of the rod introduction clamp shaft.

FIG. 11(a) is a cross-sectional view of the rod introduction clamp shaft taken along section lines 11—11.

FIG. 11(b) is a cross-sectional view of the rod introduction clamp shaft showing a threaded plug and driving member extending through the cannula.

FIG. 12 is a perspective view of the rod introduction speed nut.

FIG. 13 is a cross-sectional view of the speed nut of FIG. 12.

FIG. 14 is a partial side view of a lever mechanism according to another embodiment of the present invention.

FIG. 15 is an alternative embodiment of a rod reduction apparatus according to the present invention.

FIG. 16 is a front view of the clamp shaft of the embodiment of FIG. 15.

FIG. 17 is a front view of the outer sleeve of the embodiment of FIG. 16.

FIG. 18 is a side view of the outer sleeve of FIG. 17.

FIG. 19 is a side view of the clamp shaft of FIG. 16.

DESCRIPTION OF THE PREFERRED EMBODIMENTS

For the purposes of promoting an understanding of the principles of the invention, reference will now be made to the embodiments illustrated in the drawings and specific language will be used to describe the same. It will nevertheless be understood that no limitation of the scope of the invention is thereby intended, such alterations and further modifications in the illustrated device, and such further applications of the principles of the invention as illustrated therein being contemplated as would normally occur to one skilled in the art to which the invention relates.

Referring now to FIG. 1, a rod introduction apparatus 10 according to the present invention includes an outer sleeve 14, a clamp shaft 18 and a lateral approximator lever 12. As will be appreciated by the detailed description that follows, the rod introduction apparatus is a multiple action device having the capability of securely holding an implant (often a hook or a screw), aligning a laterally offset longitudinal member (typically a rod or a plate), reducing the vertical distance between the longitudinal member and the implant, and providing a passage for placement of a fastener into the implant while the implant and longitudinal member are held in alignment. It is understood that all of the features of the apparatus may be used in combination or only a select portion thereof may be utilized, the features utilized will depend on the needs of the surgery being performed.

Referring now to FIGS. 5 through 8, outer sleeve 14 includes on its proximal end a shoulder 46 extending around the entire circumference of the outer sleeve. Pivot pins 24 and 25 project from opposite sides of the outer sleeve. The distal end of outer sleeve 14 is the rod engagement end 40, which defines a pair of diametrically opposed rod engagement arms 62 and 63. As shown in FIG. 6, these arms have a substantially reduced width 52 in comparison to diameter of outer sleeve 14, as they extend towards the rod engagement end 40. Disposed on the distal tip of rod engagement arm 62 is a concave

recess **54** having a curvature substantially equivalent to the outside diameter of a rod. A similar concave recess **55** is disposed on the distal tip of rod engagement arm **63** and is in alignment with concave recess **54** to permit a rod to be engaged by both recesses simultaneously. It will be understood that rod engaging arms **62** and **63** have concave recesses **54** and **55** in order to hold a portion of the rod and inhibit lateral movement thereof.

FIG. 7 shows a cross-sectional view of outer sleeve **14**. The outer sleeve is a hollow substantially cylindrical tube defining an interior channel **48** extending therethrough. Interior channel **48** is substantially narrowed adjacent the distal end by inner surfaces **60** and **61** of rod engagement arms **62** and **63**, respectively. As shown in FIG. 8, an end view of outer sleeve **14** looking into the distal end, the inner sidewalls of outer sleeve **14** can form a substantially rectangular surface defining interior channel **48**.

Referring now to FIGS. 9 through 11, clamp shaft **18** is sized to be slidably received within the interior channel of outer sleeve **14**. Clamp shaft **18** includes gripping nose **22** having a portion extendable beyond the distal end of outer sleeve **14**. Gripping nose **22** includes a first clamping branch **36** and a second clamping branch separated by space **76**. The distance between first clamping branch **36** and second clamping branch **76** changes as the clamping branches are moved from their insertion position, with ramped sidewall portion extending outside outer sleeve **14**, to a clamping position with ramped sidewall portions **72** and **73** engaging bearing surfaces **60** and **61** respectively. In the preferred embodiment the clamping branches resiliently tend to assume their insertion form unless constrained by outer sleeve **14**. Preferably, clamping branches **36** and **38** have an area of reduced wall thickness defining a void **78** adjacent their attachment points to the remainder of clamping shaft **18**. This area of reduced wall thickness tends to experience the greatest amount of deflection when the clamping branches are in the clamping position. While the preferred embodiment relies on the resiliency of the clamping branches themselves to assume the insertion position, it is contemplated that a mechanical means cooperable with the clamping branches may be utilized to move the clamping branches between the insertion and clamping positions.

Each clamping branch includes a series of projections **42a** and **42b** to engage corresponding recesses **44a** and **44b** on implant **26**. While FIGS. 2 and 3 show implant **26** as a spinal hook, it is contemplated that the clamping branches may be adapted to engage a variety of implants, with or without the use of interengaging projections and recesses. In the preferred embodiment, each branch includes two projections **42a** and **42b** to engage a corresponding two recesses **44a** and **44b** on implant **26**. However, it is contemplated that the number of projections on each clamping branch can vary, depending on the number of mating recesses disposed on implant **26**. Moreover, it is contemplated that implant **26** may contain a series of projections while clamping branches may have corresponding recesses.

Disposed on the opposite end of clamp shaft **18** is T-handle **20**. Adjacent T-handle **20** and spaced by a smooth cylindrical shank portion **35**, are external threads **26** adapted to engage an internally threaded nut. Additionally, disposed between the threads **26** and the gripping nose **22** is a shoulder **86** where clamping shaft **18** transitions from a cylindrical cross section adjacent threads **26** to a substantially rectangular cross section extending to gripping nose **22**.

Referring now to FIG. 10, clamp shaft **18** has a substantially uniform width when viewed from this side, with the exception of a reduced width portion disposed between

shoulder **86** and gripping end **22**. The reduced width area is defined by sidewalls **70** and **71** and continues at a reduced width until it begins to increase at ramped portions **72** and **73**. Ramp portions terminate in sidewalls **74** and **75**, having the same width as the remainder of the clamp shaft **18**. In addition to the area of reduced outer width, in the area of reduced outer width, the walls also include reduced thickness sidewalls **80** and **82**. This area of reduced thickness creates void **78**. It will be understood that in use, as clamp shaft **18** is withdrawn into outer sleeve **14**, outer sleeve side walls **60** and **61** will engage ramps **72** and **73**, respectively, thereby urging clamping branches **36** and **38** toward one another and reducing the distance between the clamping branches. Moreover, it will be understood that a major portion of the deformation required to urge clamping branches **36**, **38** toward one another will occur in the sidewalls defining cavity **78**.

Referring now to FIG. 11(a), clamp shaft **18** has a central cannula **84** extending throughout the entire length of the shaft. Cannula **84** has a uniform diameter throughout and is adapted to receive a fastener for placement onto an implant. The internal passage for delivery of the fastening member to the implant provides an important advantage to the surgeon when the rod is being held in alignment with the implant because external passages to the implant may be obstructed or have limited clearance because of the presence of the rod reduction apparatus. In the preferred embodiment, an externally threaded plug **88** (FIG. 11(b)) may be placed into the cannula and urged into engagement with an internally threaded opening in hook **26**. An elongated driving member **89** is then inserted through cannula **84** and engaged with threaded plug **88** to threadedly insert the plug into a corresponding threaded opening in the implant. Although an externally threaded plug is shown in this embodiment, it is contemplated that an internally threaded nut could be passed through cannula **84** to engage an externally threaded portion of a hook or a screw. The internally threaded nut could then be tightened by engagement of projections on a tightening tool with corresponding recesses in the nut.

Speed nut **16** of the present invention is of conventional design (FIGS. 12 and 13) and is rotatably mounted on outer sleeve **14**. Speed nut **16** includes a central threaded opening **65** sized to freely slide over smooth shank portion **35** of clamping shaft **18**. Threads **17** are adapted to engage cooperable threads **28** on clamping shaft **18**. Bearing surface **58** surrounds threaded opening **65** and forms an internal bearing surface for bearing against outer sleeve **14**. Extending through the sidewall of the nut **16** are a series of openings **56** and **57** (and a third opening not shown), each adapted to receive a retaining pin. In the preferred embodiment, speed nut **16** has a series of projections **66** on its outer surface for ease of gripping during the turning process.

Preferably, the rod insertion apparatus of the present invention includes a lateral approximator mechanism to bring an implant into alignment with a laterally offset longitudinal member. In the preferred embodiment, the lateral approximator mechanism is a lateral approximator lever **12** pivotally attached to outer sleeve **14** (FIG. 1). Lateral approximator lever **12** defines a pair of keyways **13** and **15** (FIG. 3) adapted to selectively engage a pair of pivot pins **24** and **24** on outer sleeve **14**. The proximal end **31** of lever **12** is configured to be a handle for manually manipulating the lever to urge a laterally offset rod and implant into alignment.

The rod engaging end **30** of lever **12** is bifurcated into a first lever arm **29** and a second lever arm **33**. Each arm freely passes over the outer surface of outer sleeve **14**. First lever arm **29** has a rod engaging hook **32** disposed at its distal end. Likewise, second lever arm **33** has a corresponding rod

engaging hook **34** disposed at its distal end and in alignment with engaging hook **32** permitting both hooks to contact a rod simultaneously. It is contemplated that the extent of lever arm extending distally beyond hooks **32** and **34** should be minimized in order to limit contact with surrounding anatomical structures during the lateral approximation procedure and the vertical reduction procedure if performed.

The above-described components of the rod introduction apparatus of the present invention are assembled as follows. Clamp shaft **18** as shown in FIGS. **9** through **11**, is inserted into outer sleeve **14** with surfaces **70** and **72** aligned with surfaces **60** and **61** of the outer sleeve, respectively. Speed nut **16** is then passed over the proximal end **29** of clamp shaft **18** until bearing surface **58** abuts shoulder **46** on outer sleeve **14**. A series of retaining pins **19**, **21** and a third pin (not shown) are placed in the openings **56**, **57** and a third opening in nut **16** (not shown). The retaining pins extend into the space between nut **16** and outer sleeve **14**. Nut **16** is thereby retained on shoulder **46** by bearing surface **58** and a series of retaining pins.

In the preferred embodiment, T-handle **20** having a central opening aligned with cannula **84** is added for ease of manipulation of clamp shaft **18** within outer sleeve **14**. In the preferred embodiment, T-handle **20** is welded onto clamp shaft **18**, although it is contemplated that other means such as brazing or threading may be used to attach T-handle **20**. It is contemplated that a separate handle is not required, instead, the surface of clamp shaft **18** may be roughened for easy gripping by the surgeon or the shaft may be machined to define an enlarged area for gripping. Finally, at the option of the user, lateral rod approximator lever slides about the outer surface of outer sleeve **14** to pass key way **13** and corresponding key way **15** on the opposite side of lever **12** over pivot pins **24** and **25**, respectively. In the preferred embodiment, lateral approximator lever **12** can be selectively interconnected with the outer sleeve, thus permitting the lever to be added or removed at the user's discretion.

As shown in FIG. **14**, it is contemplated that a lateral approximator lever **90** having rod engaging end **91** with rod hook **94** could be pivotally attached to outer sleeve **14** in a non-removable fashion. In this embodiment, lever **90** is pivotally attached to outer sleeve **14** by a pivot pin **92** and a similar pivot pin (not shown) disposed on the opposite side of outer sleeve **14**. Moreover, in this embodiment, lever **90** is provided with a mechanical means to urge the rod and implant into lateral alignment. The mechanical mechanism extends through oblong opening **93** in lever **90**. A threaded shaft **95** is pivotally connected to outer sleeve **14** by a pin **96**. An enlarged finger nut **97** is threaded onto threaded shaft **95** to urge lever **90** into the desired position.

Referring now to FIGS. **2** through **4**, in operation, the rod introduction apparatus of the present invention may be utilized to both laterally approximate a spinal rod to an implant having an opening for receiving a rod and to vertically reduce the rod into the opening of the implant. As will be appreciated by those skilled in the art, clamp shaft **18** is free to slide within outer sleeve **14** when threads **28** are not engaged with speed nut **16**. In a first area of freedom of movement, clamp shaft **18** is free to move the length of smooth shank portion **35** disposed between threads **28** and T-handle **20**. In this position, gripping nose **22** may be extended a substantial distance beyond the rod engagement end **40** of outer sleeve **14** into the insertion position in preparation for securely clamping an implant. It will be understood that with T-handle engaging speed nut **16**, space **76** between clamping branches **36** and **38** will be at its maximum, thereby permitting the clamping branches to extend around an implant. As clamp shaft **18** is

manually withdrawn into outer sleeve **14**, ramp surfaces **72** and **73** of the clamp shaft bear against surfaces **60** and **61** of the outer sleeve, thereby urging clamping branches **36** and **38** toward one another and into the clamping position. It is contemplated that the action of drawing clamp shaft **18** within outer sleeve **14** is performed only after aligning projections **42** with the corresponding recesses **44** in the implant **26**. In this manner, the implant may be securely gripped by the rod introduction apparatus of the present invention. At this point, speed nut **16** may be partially rotated to engage at least a portion of threads **28** in order to securely hold clamp shaft **18** in the clamping position.

Once the implant has been securely gripped, the spinal rod **50** may then be aligned with the opening in the implant, both laterally and vertically. For lateral approximation, lateral rod approximator lever **12** is positioned as previously described about the outer sleeve **14** and pivotally connected with pivot pins **24** and **25**. As shown in FIG. **2**, the upper end **31** of lever **12** is displaced from the body of outer sleeve **14**, thereby pivoting about the pivot pins and extending the rod engaging portion **30** of the lever a sufficient distance laterally from the outer sleeve to securely engage spinal rod **50** within hooks **32** and **34**. After hooks **32** and **34** are securely engaged with rod **50**, the upper end **31** of lever **12** is urged back into alignment with outer sleeve **14**, thereby urging spinal rod **50** into alignment with rod engagement end **40** of the outer sleeve. Once this position has been achieved, the vertical displacement between rod **50** and implant **26** may then be reduced. Speed nut **16** is rotated while engagement with threads **28** to urge gripping nose **22** of clamping shaft **18** to be drawn into outer sleeve **14**. As the clamping shaft is drawn into the outer sleeve, rod engagement end **40** approaches gripping nose **22** and thereby forces rod **50** into implant opening **27**. Once in the final position (FIG. **4**), implant **26** may be secured to rod **50** by any number of means, which include a threaded plug or blocking sleeve. In the preferred embodiment, clamp shaft **18** includes a cannula **84** extending therethrough. Once the rod has been positioned within the opening **27** of implant **26**, a threaded plug **88** is passed through cannula **84** until it seats into the correspondingly threaded opening in implant **26**. A driving member extending through cannula **84** is used to tighten the plug in the implant. Threaded plug **88** securely holds the rod in the implant opening.

Once the rod has been secured to the implant, rod adjustability lever **12** is rotated away from engagement with outer sleeve **14**, thereby releasing the rod **50**. Further, speed nut **16** is rotated to urge gripping nose **22** out of outer sleeve **14** and thereby separate rod engagement end **40** from rod **50**. Speed nut **16** is continued to be rotated until it no longer engages threads **28**, which thereby allows clamp shaft **18** to slide within outer sleeve until handle **20** engages speed nut **16**. This movement permits clamping branches **36** and **38** to assume the insertion position and thereby release the implant. Once released, the rod introduction apparatus of the present invention may then be withdrawn.

Referring now to FIGS. **15** through **19**, an alternative embodiment of the rod introduction apparatus according to the present invention includes outer sleeve **110**, clamping shaft **118**, and lateral approximator lever **112**. Similar to the first described embodiment, rod reduction apparatus **101** is capable of gripping an implant, engaging a laterally offset longitudinal member and aligning the implant and offset longitudinal member and reducing the vertical distance between the implant and longitudinal member.

In this embodiment, clamping shaft **118** comprises two articulating branches **142** and **143** pivoting about a connecting pivot pin **144** (FIG. **16**). While the branches illustrated do

11

not define an internal cannula, it is contemplated that for certain applications it may be desirable that each branch form a portion of a cannula adapted for insertion of a fastener. Distally of pivot pin 144, articulating branches 142 and 143 define clamping branches 138 and 136, respectively. Clamping branches 136 and 138 have projections 146 and 145, respectively, adapted to engage corresponding recesses (not shown) in screw 126. Articulating movement of branches 142 and 143 moves clamping branches 136 and 138 between an insertion position with clamping branches spaced by a first larger distance and a clamping position with clamping branches spaced by a second smaller distance. The branches are held in the clamping position by retaining cap 140 pivotally connected to branch 143 and selectively engaging branch 142. Articulating branch 142 further includes a rack 117 disposed on its outer surface.

Outer sleeve 110 includes mounting brackets 113 and 144. An opening (not shown) is formed in the sidewall of outer sleeve 110 between mounting brackets 113 and 114. Pinion 116 is pivotally mounted to mounting brackets 113 and 144 with a portion of the pinion extending through the opening and into the interior channel of outer sleeve 110.

Lateral rod approximation lever 112 is pivotally mounted to outer sleeve 110 by pivot pins 124 and 125. The rod engaging end 120 of lever 112 includes a pair of hooks 121 and 122 for engaging a rod. As shown in FIG. 18, each hook includes an upper projection 151 for securely engaging the rod during vertical reduction.

In operation, articulating branches 142 and 143 are separated to position clamping branches 136 and 138 in the insertion position. The clamping branches are positioned adjacent screw 126 with projections 145 and 146 aligned with corresponding recesses (not shown) in screw 126. Articulating branches are then brought together, thereby urging projections into the screw recesses to securely hold the implant. Retaining cap 140 is then rotated about pin 141 until the cap securely engages articulating branch 142. In this manner, the branches remain in the clamping position.

After the implant has been securely clamped, outer sleeve 110 with interconnected lever 112 and pinion 116 is slid over clamping shaft 118 with pinion 116 aligned with rack 117 and is urged downwardly until pinion 116 engages rack 117. Lever 112 is then positioned to engage rod 150. Lever 112 is moved to bring rod 150 into lateral alignment with screw 126. Pinion 116 is then rotated to urge outer sleeve 110 towards screw 126 thereby urging engaged rod 150 into vertical alignment with screw 126. In the illustrated embodiment, screw 126 is a variable angle screw engagable by an eyebolt mechanism previously placed on rod 150. Such an eyebolt attachment mechanism is offered by Sofamor Danek Group as the TSRH™ Variable Angle Eyebolt. Once in alignment, the eyebolt mechanism is utilized to securely interconnect the screw and rod.

Once screw and rod are interconnected, pinion 116 must be reversed to move outer sleeve 110 away from screw 126. Once pinion 116 is free of rack 117, outer sleeve 110 may be removed. Retaining cap 140 is then removed from articulating branch 142, thereby permitting the branches to disengage screw 126.

While the invention has been illustrated and described in detail in the drawings and foregoing description, the same is to be considered as illustrative and not restrictive in character, it being understood that only the preferred embodiments have been shown and described and that all changes and modifications that come within the spirit of the invention are desired to be protected.

12

What is claimed is:

[1. A multiple action insertion apparatus for engaging a longitudinal member and an implant, comprising:

an implant holder including a first clamping branch and a second clamping branch cooperable with said first clamping branch to hold to an implant;

a reduction mechanism interconnected with said implant holder, said reduction mechanism having a distal end for engaging the longitudinal member, wherein said reduction mechanism urges the longitudinal member into vertical alignment with the implant; and

a lateral approximator mechanism interconnected with said implant holder, said lateral approximator mechanism having a distal end disposed adjacent said first and second clamping branches, said distal end adapted to engage the longitudinal member, wherein said lateral approximator mechanism urges the longitudinal member into lateral alignment with the implant.]

[2. The insertion apparatus of claim 1, wherein said lateral approximator mechanism is a lever arm pivotally connected to said implant holder.]

3. [The insertion apparatus of claim 1,] *A multiple action insertion apparatus for engaging a longitudinal member and an implant, comprising:*

an implant holder including a first clamping branch and a second clamping branch cooperable with, and movable relative to, said first clamping branch to hold to an implant;

a reduction mechanism interconnected with said implant holder, said reduction mechanism having a distal end for engaging the longitudinal member, wherein said reduction mechanism urges the longitudinal member into vertical alignment with the implant; and

a lateral approximator mechanism interconnected with said implant holder, said lateral approximator mechanism having a distal end disposed adjacent said first and second clamping branches, said distal end adapted to engage the longitudinal member, wherein said lateral approximator mechanism urges the longitudinal member into lateral alignment with the implant,

wherein said implant holder comprises a shaft having a gripping end with a portion, said gripping end defining a first clamping branch and a cooperable second clamping branch, said first and second clamping branches tending to assume an insertion position defining a first distance between said first and second clamping branches, and said first and second clamping branches compressible into a clamping position defining a second distance between said first and second clamping branches, said first distance greater than said second distance; and

a sleeve defining an interior channel, said shaft slidably received within said interior channel, said shaft moveable between a first position with said portion extending from said sleeve and a second position with said portion drawn into said sleeve;

wherein movement of said shaft within said tubular sleeve from said first position to said second position controls said first and second clamping branches from said insertion position to said clamping position.

4. The introduction apparatus of claim 3, wherein said reduction apparatus comprises a series of external threads disposed on said shaft and an internally threaded nut rotatably mounted on said sleeve, said internally threaded nut cooperable with said external threads, said sleeve further defining a bearing surface adjacent said gripping end for engaging the longitudinal member, wherein rotation of said nut moves said shaft with respect to said sleeve and urges said bearing surface

13

against the longitudinal member thereby reducing the distance between the longitudinal member and the implant.

5. The introduction apparatus of claim 4, wherein the longitudinal member is a rod and said bearing surface is a recessed area on said sleeve.

[6. A multiple action insertion apparatus for engaging a longitudinal member and an implant, comprising:

means for attaching to an implant;

means for lateral approximation of a longitudinal member laterally offset from the implant, said means for lateral approximation interconnected with said means for attaching; and

means for vertical reduction of the longitudinal member vertically offset from the implant, said means for vertical reduction interconnected with said means for attaching, wherein said means for lateral approximation laterally aligns the longitudinal member over the implant and said means for vertical reduction vertically aligns the longitudinal member with the implant.]

[7. An implant holder for holding an implant adapted to receive a fastener, comprising:

means for gripping the implant said means for gripping including a gripping end and a handle defining a longitudinal cannula having a distal end adjacent said gripping end, said cannula adapted to receive a fastener cooperable with said implant;

wherein said means for gripping includes a first clamping branch and a second clamping branch defining said gripping end, said first and second clamping branches aligned in a spaced relationship and cooperable to engage the implant, and wherein said handle defines a series of threads opposite said gripping end, and further including a sleeve defining an internal channel adapted to receive at least a portion of said gripping end and said handle, and a nut rotatably mounted on said sleeve, said nut cooperable with said threads on said handle.]

[8. The implant holder of claim 7, wherein said sleeve has a distal end adjacent said gripping end and said sleeve defines a bearing surface adapted to bear against a longitudinal member, wherein rotation of said nut draws said handle into said sleeve and thereby reduces the distance between the implant engaged by said first and second clamping branches and the longitudinal member bearing against said bearing surface of said sleeve.]

[9. The implant holder of claim 8, further including a lateral approximating lever pivotally attached to said sleeve.]

10. An implant holder for gripping an implant, comprising: a shaft having a gripping end with a portion, said gripping end defining a first clamping branch and a cooperable second clamping branch, said first and second clamping branches tending to assume an insertion position defining a first distance between said first and second clamping branches, and said first and second clamping branches compressible into a clamping position defining a second distance between said first and second clamping branches, said first distance greater than said second distance; [and]

a sleeve defining an interior channel, said shaft slidably received within said interior channel, said shaft moveable between a first position with said portion extending from said sleeve and a second position with said portion drawn into said sleeve; and

an actuating mechanism for moving said shaft within said tubular sleeve, said actuating mechanism provided about said tubular sleeve and an actuating force for operating said actuating mechanism applied about the tubular sleeve,

14

wherein movement of said shaft within said tubular sleeve from said first position to said second position controls said first and second clamping branches from said insertion position to said clamping position.

11. The implant holder of claim 10, wherein said sleeve defines an engagement surface for engaging a longitudinal member to be interconnected with said implant, whereby positioning said shaft in said second position clamps the implant and further movement of said inner shaft into said sleeve urges the implant into alignment with the longitudinal member.

12. The implant holder of claim 11, [further including means for controlling the position of said shaft within said sleeve] *wherein said actuator mechanism comprises threads provided about the central opening of said tubular sleeve.*

13. The implant holder of claim 12, wherein said [means for controlling] *actuator mechanism* includes an external thread disposed on said inner shaft and a nut rotatably mounted on said tubular sleeve, said nut having an internal thread corresponding to said external thread, whereby said inner shaft may be drawn into said outer sleeve by rotation of said nut.

14. The implant holder of claim 11, wherein said *threads on said shaft* [includes] *are formed as* a series of external threads and *said shaft* further [including] *includes* an internally threaded nut rotatably mounted on said sleeve, said internally threaded nut cooperable with said external threads, wherein rotation of said nut moves said shaft with respect to said sleeve.

15. The implant holder of claim 14, further including a lateral approximator lever pivotally engaging said sleeve, said lateral approximator lever having a rod engaging end adapted to engage a laterally offset rod, wherein upon engaging a laterally offset rod, said lateral approximator lever may be pivoted toward said sleeve, thereby positioning the rod adjacent the implant.

16. The implant holder of claim 15, wherein said first and second clamping branches each have a distal end and include at least one projection defined on each of said distal ends.

17. The implant holder of claim 10, wherein said shaft includes a handle disposed opposite said gripping, said handle utilized to position said shaft within said sleeve.

18. The implant holder of claim 10, wherein said shaft is cannulated to slidably receive a fastening member adapted to be engaged with the implant.

19. The implant holder of claim 10, wherein said attachment to said implant is a non-pivotal attachment.

20. The implant holder of claim 10, further including a lateral approximator lever pivotally engaging said sleeve, said lateral approximator lever having a rod engaging end adapted to engage a laterally offset rod, wherein upon engaging a laterally offset rod, said lateral approximator lever may be pivoted toward said sleeve, the rod is positioned adjacent the implant.

21. The implant holder of claim 20, wherein said lateral approximator lever removably engages said sleeve, whereby said lever may be selectively removed.

22. The implant holder of claim 10, wherein said first and second clamping branches each have a distal end and include at least one projection defined on said distal end.

23. The implant holder of claim 10, wherein said shaft defines a cannula having a distal end adjacent said first and second clamping branches, said cannula adapted to slidably receive a fastener, whereby said fastener is delivered through said cannula to said distal end for interengagement with the implant.

15

24. An implant holder having a rod reduction mechanism for vertically aligning a longitudinal member and an implant, comprising:

means for gripping the implant;
 a sleeve having an axis and a distal end adapted to engage 5
 the longitudinal member, said sleeve having an axial bore sized to receive said means for gripping, said means for gripping slidably received within said axial bore; and
threaded means for axially displacing said sleeve with respect to said means for gripping, whereby a [vertical] 10
vertically offset longitudinal member is urged into alignment with the implant.

25. The implant holder of claim 24, wherein said means for gripping are articulating forceps.

26. The implant holder of claim 24, wherein said means for axial displacement includes a series of threads disposed on said means for gripping and a nut rotatably mounted on said sleeve and threadedly engagable with said threads. 15

27. The implant holder of claim 24, wherein said means for axial displacement includes a rack disposed on said means for gripping and a pinion pivotally mounted on said sleeve and interengagable with said rack. 20

28. A method for interconnecting a longitudinal member and an implant adapted to engage the longitudinal member, comprising the steps of: 25

providing an introduction apparatus having an attachment mechanism with a cannula and a vertical reduction mechanism;
 attaching the introduction apparatus to the implant;
 operating the vertical reduction mechanism, *by actuating a threaded engagement mechanism of the vertical reduction mechanism*, to force the longitudinal member into alignment with the implant;
 inserting a fastener through the cannula;
 interconnecting the fastener and the implant, wherein the longitudinal member is securely attached to the implant;
 and
 removing the introduction apparatus.

[29. A method for interconnecting a longitudinal member and an implant adapted to engage the longitudinal member, comprising the steps of: 40

providing an introduction apparatus having an attachment mechanism, a lateral approximation lever, and a vertical reduction mechanism;
 attaching the introduction apparatus to the implant;
 engaging a laterally offset longitudinal member with one end of the lateral approximator lever;
 rotating the lever to urge the longitudinal member into lateral alignment with the implant;
 operating the vertical reduction mechanism to force the longitudinal member into vertical alignment with the implant; and
 interconnecting the longitudinal member and the implant.] 50

30. [The method of claim 29.] *A method for interconnecting a longitudinal member and an implant adapted to engage the longitudinal member, comprising the steps of: 55*

providing an introduction apparatus having an attachment mechanism, a lateral approximation lever, and a vertical reduction mechanism;
attaching the introduction apparatus to the implant;
engaging a laterally offset longitudinal member with one end of the lateral approximator lever;
rotating the lever to urge the longitudinal member into lateral alignment with the implant;
operating the vertical reduction mechanism to force the longitudinal member into vertical alignment with the implant; and 65

16

interconnecting the longitudinal member and the implant, wherein the providing step includes providing attachment mechanism having a cannula and further including the step of delivering a fastener through the cannula and to the implant prior to interconnecting the longitudinal member and the implant.

31. *A method for interconnecting a longitudinal member and an implant adapted to engage the longitudinal member, comprising the steps of:*

providing an introduction apparatus having an attachment mechanism with attachment prongs for attaching to the implant, a cannula and a vertical reduction mechanism;
attaching the introduction apparatus to the implant;
operating the vertical reduction mechanism to force the longitudinal member into alignment with the implant;
inserting a threaded fastener through the cannula;
interconnecting the fastener and the implant, wherein the longitudinal member is securely attached to the implant; and

removing the introduction apparatus,
wherein the introduction apparatus further comprises an elongated member that extends through the cannula, the elongated member engaging the fastener in said interconnecting step to cause the fastener to interconnect with the implant. 25

32. *The method of claim 31, wherein the attachment prongs are formed on the proximal end of the cannula.*

33. *The method of claim 32, wherein the implant is a bone screw.*

34. *The method of claim 33, wherein the longitudinal member is an implantable rod.*

35. *The method of claim 32, wherein the elongated member is separate from the vertical reduction mechanism.*

36. *The method of claim 32, wherein the introduction apparatus further comprises an actuator for operating the vertical reduction mechanism in said operating step, and the actuator connects to the distal end of the cannula about a circumference of the distal end.*

37. *The method of claim 36, wherein the implant contains a threaded opening that receives the threaded fastener in said interconnecting step.*

38. *The method of claim 31, wherein the operating and inserting steps take place separately.*

39. *An implant holder for gripping an implant, comprising: a shaft having a gripping end with a portion, said gripping end defining a first clamping branch and a cooperable second clamping branch, said first and second clamping branches tending to assume an insertion position defining a first distance between said first and second clamping branches, and said first and second clamping branches compressible into a clamping position defining a second distance between said first and second clamping branches, said first distance greater than said second distance; and*

a sleeve defining an interior channel, said shaft slidably received within said interior channel, said shaft moveable between a first position with said portion extending from said sleeve and a second position with said portion drawn into said sleeve;

wherein movement of said shaft within said tubular sleeve from said first position to said second position controls said first and second clamping branches from said insertion position to said clamping position, and wherein said implant holder further comprises an actuator for moving said shaft relative to said tubular sleeve, said actuator comprising a first portion engaging a first side of said sleeve and a second portion engaging a second

17

side of said sleeve opposite said first side, said first and second portions moving relative to said shaft to actuate movement of said sleeve.

40. *A system for spinal, surgery comprising: said implant holder of claim 39; a series of implants; and a longitudinal member, wherein said implant holder grips each of said series of implants, and wherein the relative movement of said shaft and said tubular sleeve of said implant holder operate to reduce said longitudinal member to connect to an implant of said series of implants.*

41. *The system of claim 40, wherein said series of bone implants are bone screws and said longitudinal member is a rod.*

42. *The system of claim 41, wherein said shaft defines a passage through which a fastener for fastening said rod to a bone screw is insertable, while said first and second clamping branches grip said bone screw in the clamping position.*

43. *The system of claim 42, wherein a distal opening of said sleeve has an arcuate engaging edge for engaging said rod when said shaft and said sleeve are actuated relative to each other, said engaging edge operating to reduce said rod.*

18

44. *The system of claim 43, wherein said actuator is symmetrical with respect to opposing sides of said shaft.*

45. *A system for spinal surgery comprising: the insertion apparatus of claim 40; a series of implants; and a longitudinal member, wherein said implant holder grips each of said series of implants, and wherein the relative movement of said shaft and said tubular sleeve of said implant holder operate to reduce said longitudinal member to connect to an implant of said series of implants.*

46. *A system for spinal surgery comprising: said implant holder of claim 10; a series of implants; and a longitudinal member, wherein said implant holder grips each of said series of implants, and wherein the relative movement of said shaft and said tubular sleeve of said implant holder operate to reduce said longitudinal member to connect to an implant of said series of implants.*

* * * * *