

US00RE43414E

(19) **United States**
(12) **Reissued Patent**
Walters et al.

(10) **Patent Number:** **US RE43,414 E**
(45) **Date of Reissued Patent:** **May 29, 2012**

(54) **SYNTHETIC RIPPLE REGULATOR**

(75) Inventors: **Michael M. Walters**, Apex, NC (US);
Vladimir Muratov, Manchester, NH
(US); **Stefan Wlodzimierz Wiktor**,
Raleigh, NC (US)

(73) Assignee: **Intersil Americas Inc.**, Milpitas, CA
(US)

(21) Appl. No.: **12/255,346**

(22) Filed: **Oct. 21, 2008**

Related U.S. Patent Documents

Reissue of:

(64) Patent No.: **7,132,820**
Issued: **Nov. 7, 2006**
Appl. No.: **10/853,733**
Filed: **May 25, 2004**

U.S. Applications:

(63) Continuation-in-part of application No. 10/236,787,
filed on Sep. 6, 2002, now Pat. No. 6,791,306.

(51) **Int. Cl.**
G05F 1/40 (2006.01)

(52) **U.S. Cl.** **323/288**; 323/282; 323/285

(58) **Field of Classification Search** 323/282-288,
323/222, 224, 280; 363/16, 89, 95, 97, 98,
363/132

See application file for complete search history.

(56) **References Cited**

U.S. PATENT DOCUMENTS

4,413,224 A 11/1983 Krupka et al.
4,521,726 A 6/1985 Budnik

4,658,204 A 4/1987 Goodwin
5,399,958 A 3/1995 Iyoda
5,514,947 A * 5/1996 Berg 323/282
6,064,187 A * 5/2000 Redl et al. 323/285
6,147,478 A * 11/2000 Skelton et al. 323/288
6,433,525 B2 8/2002 Muratov et al.
6,495,995 B2 12/2002 Groom et al.
6,583,610 B2 6/2003 Groom et al.
7,132,820 B2 * 11/2006 Walters et al. 323/288
7,768,246 B2 8/2010 Huang et al.

FOREIGN PATENT DOCUMENTS

DE 3343883 A1 6/1984
DE 42 06 478 A1 9/1993
EP 0 650 250 A1 4/1995
EP 0 883 051 A1 12/1998
EP 1 703 187 A2 1/2001
FR 2 610 149 A1 7/1988

* cited by examiner

Primary Examiner — Rajnikant Patel

(74) *Attorney, Agent, or Firm* — Gary R. Stanford

(57) **ABSTRACT**

A synthetic ripple regulator including a synthetic ripple voltage generator that generates a synthetic ripple voltage indicative of the ripple current through an output inductor. The regulator uses the synthetically generated ripple voltage to control toggling of a hysteretic comparator for developing the pulse width modulation (PWM) signal that controls switching of the regulator. In a non-limiting implementation, a transconductance amplifier monitors the phase node voltage of the inductor and supplies an inductor voltage-representative current to a ripple capacitor, which produces the synthetic ripple voltage. Using the replicated inductor current for ripple regulation results in low output ripple, input voltage feed forward, and simplified compensation.

38 Claims, 4 Drawing Sheets

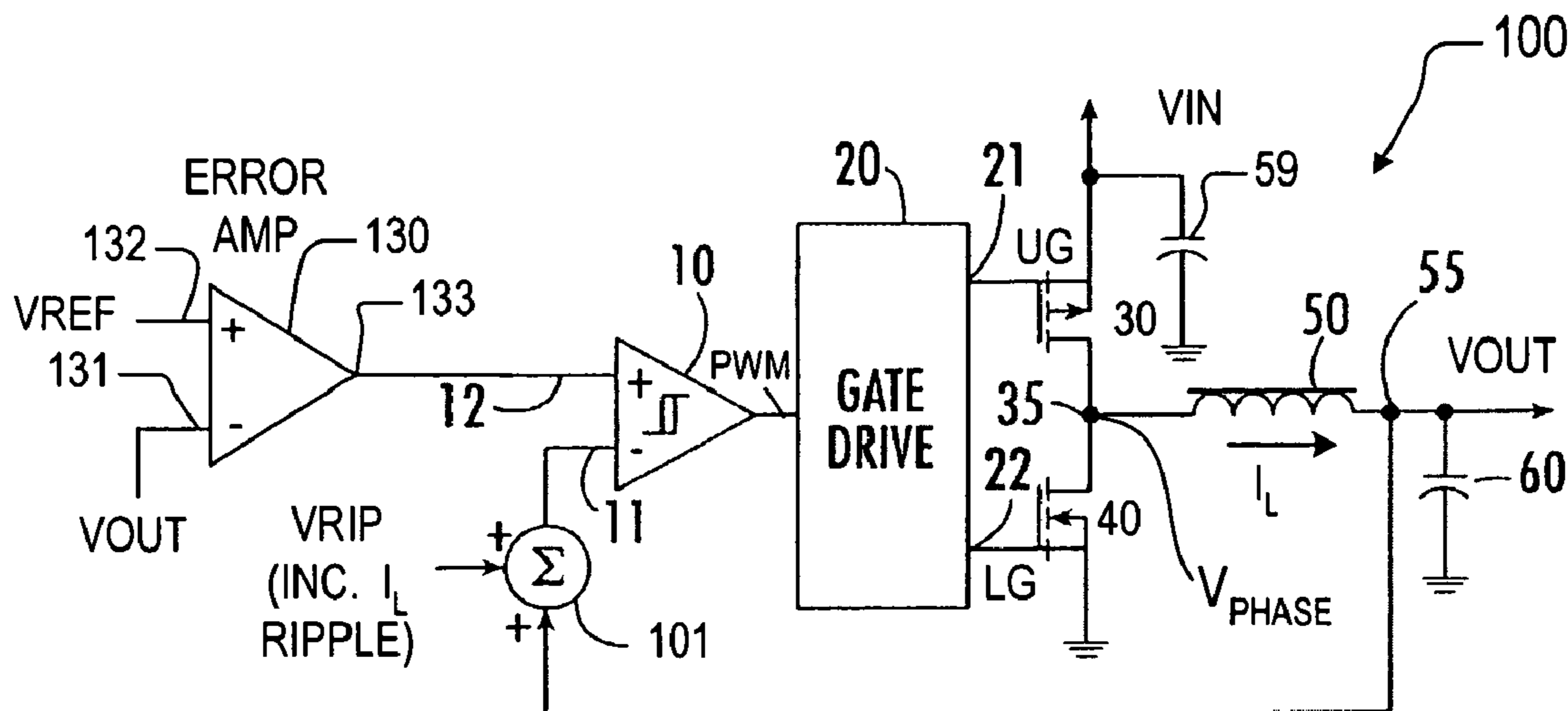

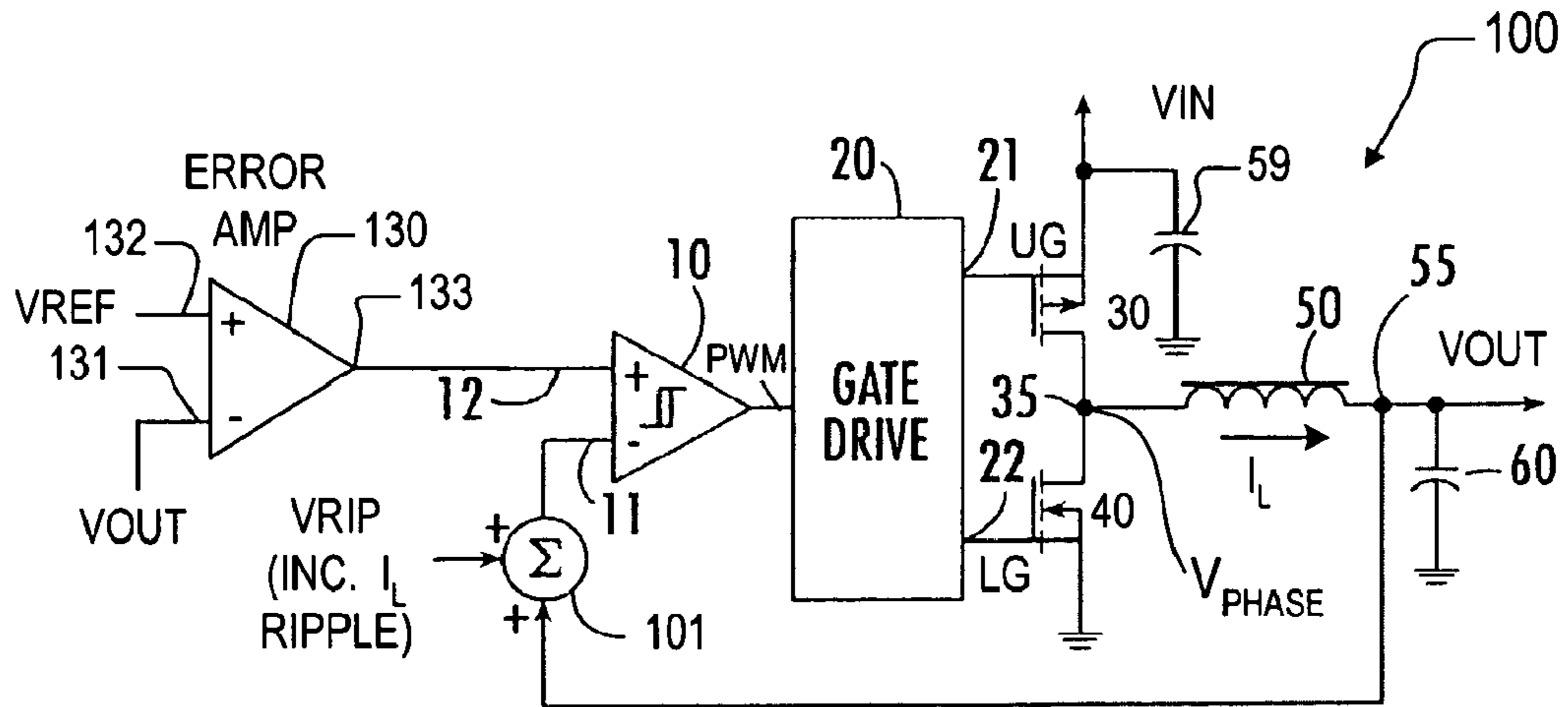

FIG. 1

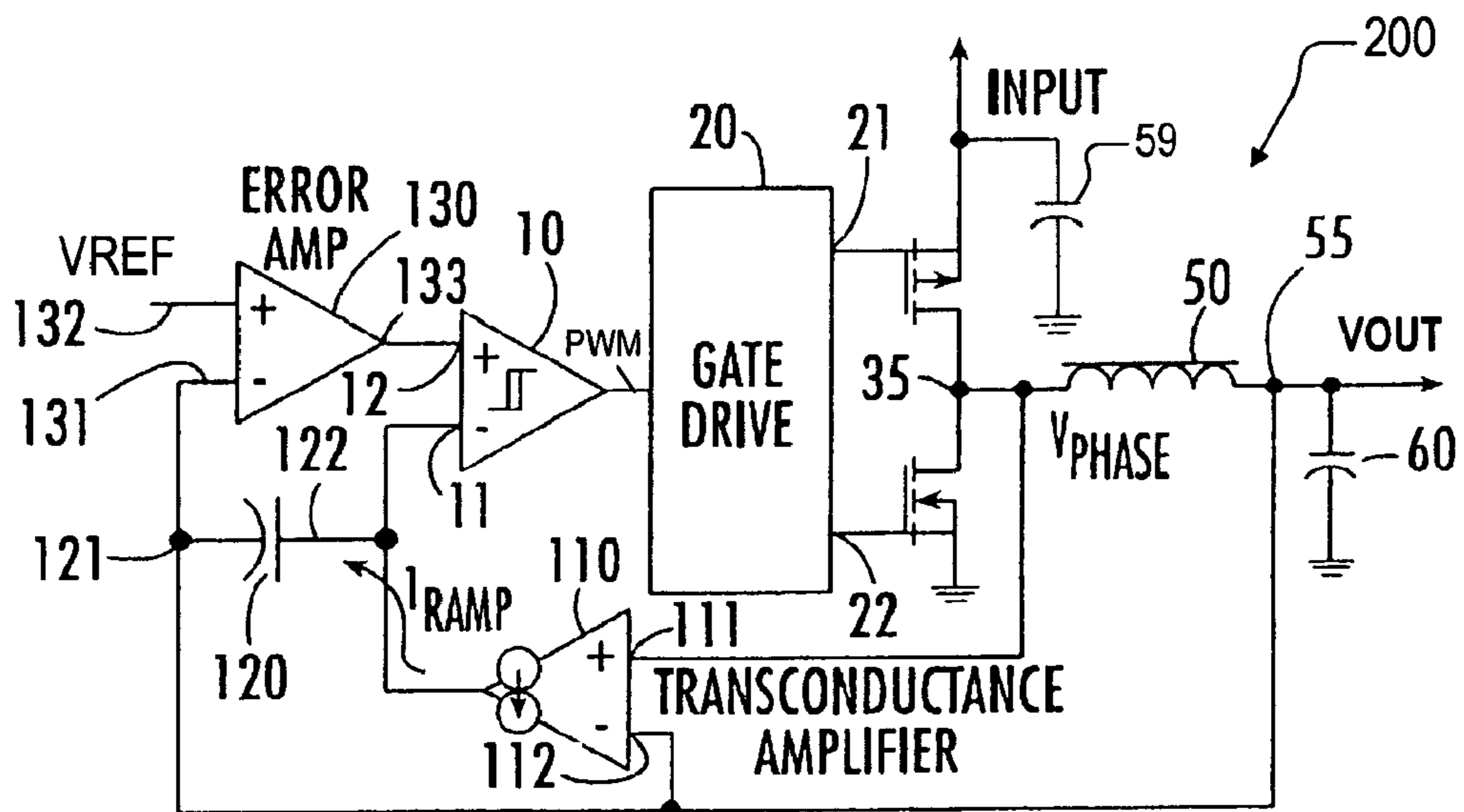

FIG. 2

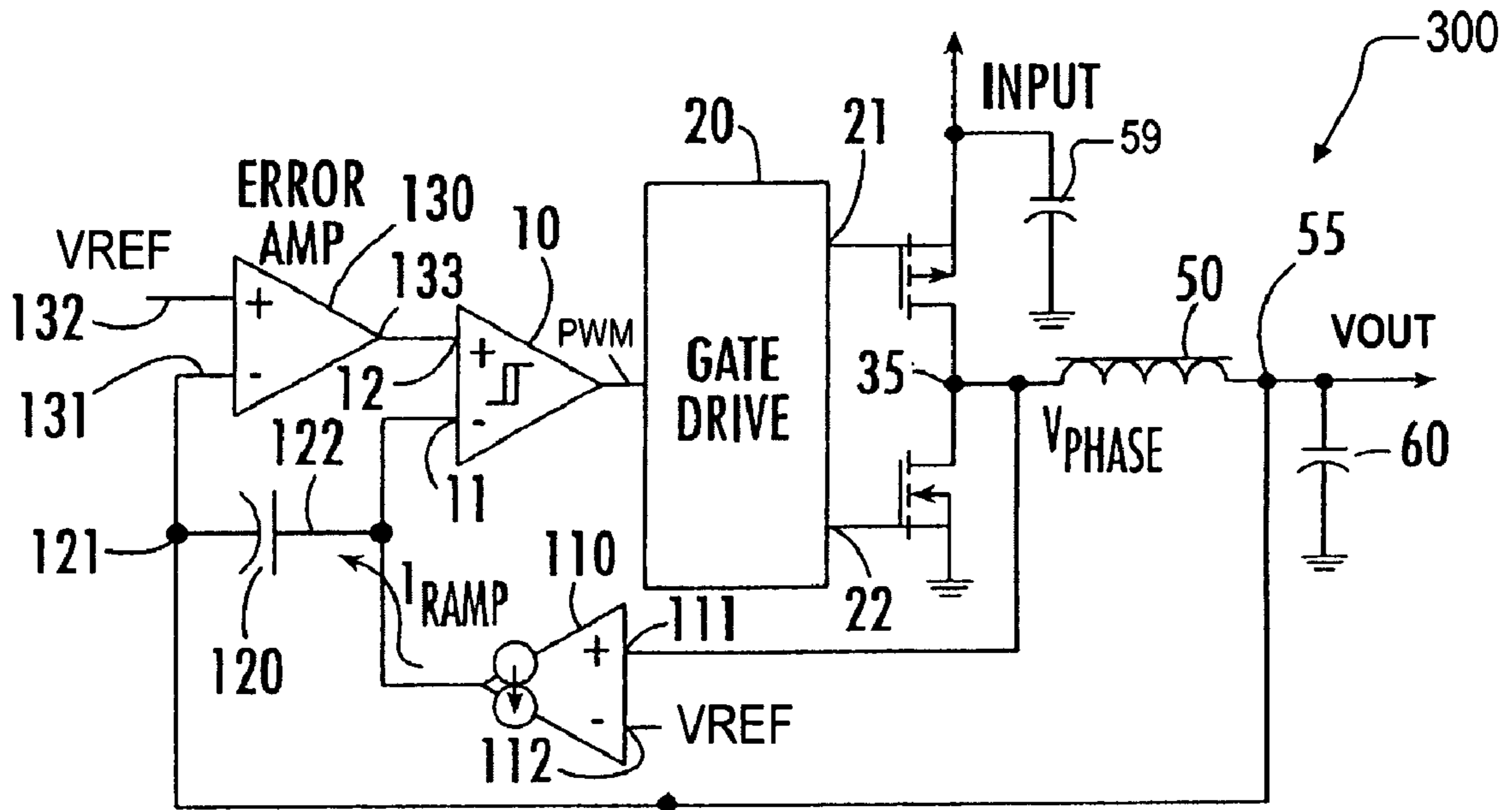

FIG. 3

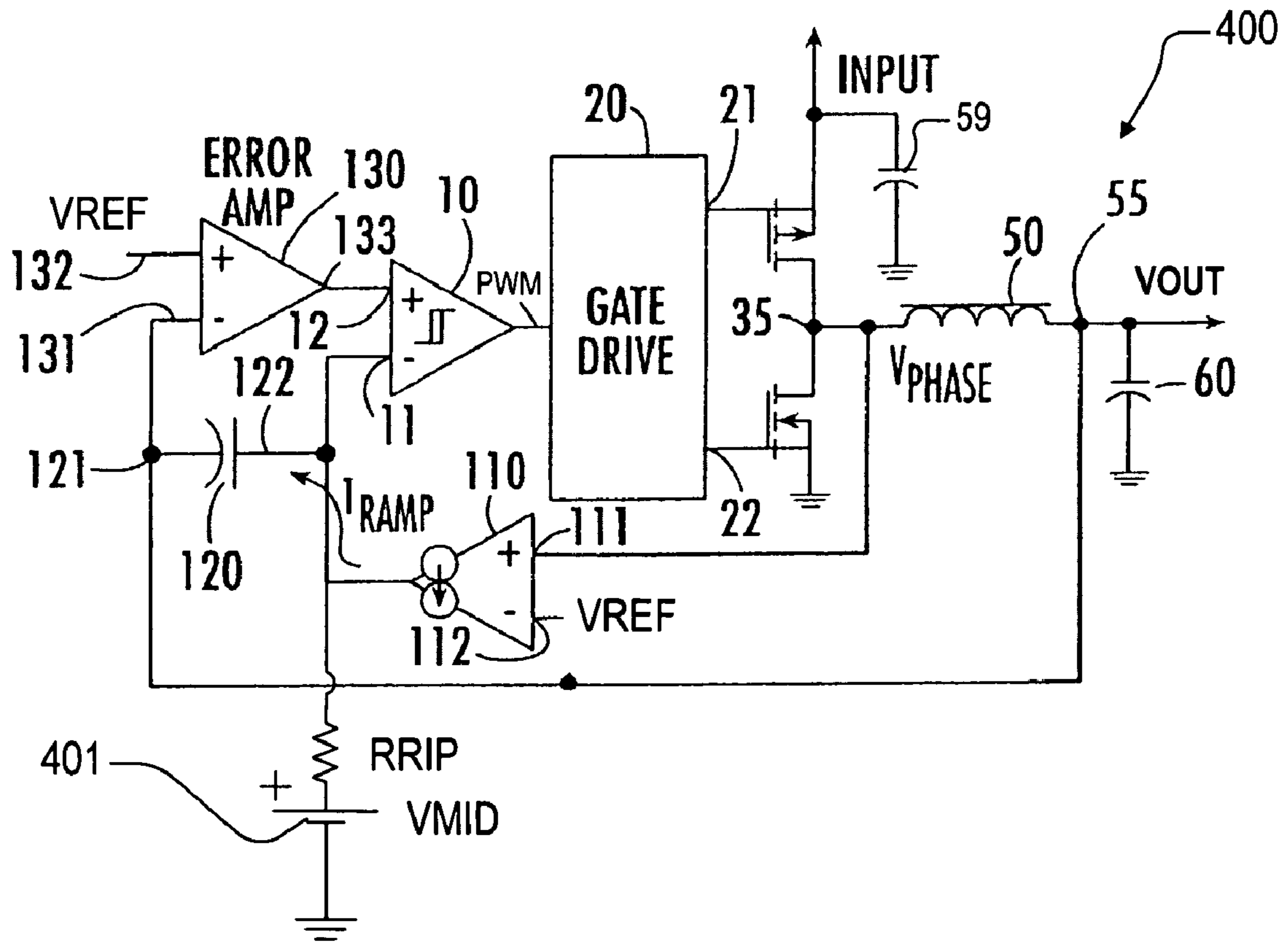

FIG. 4

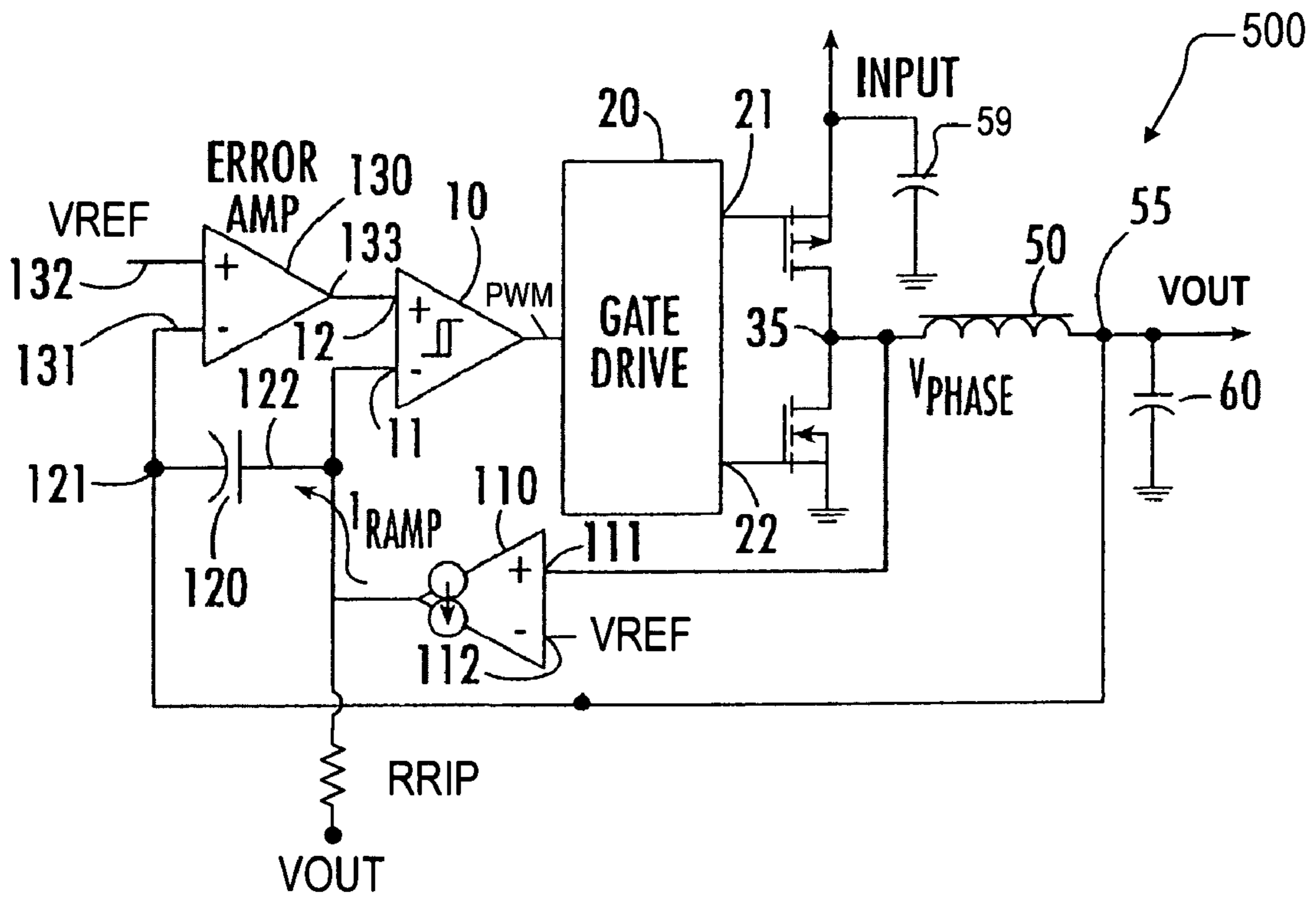

FIG. 5

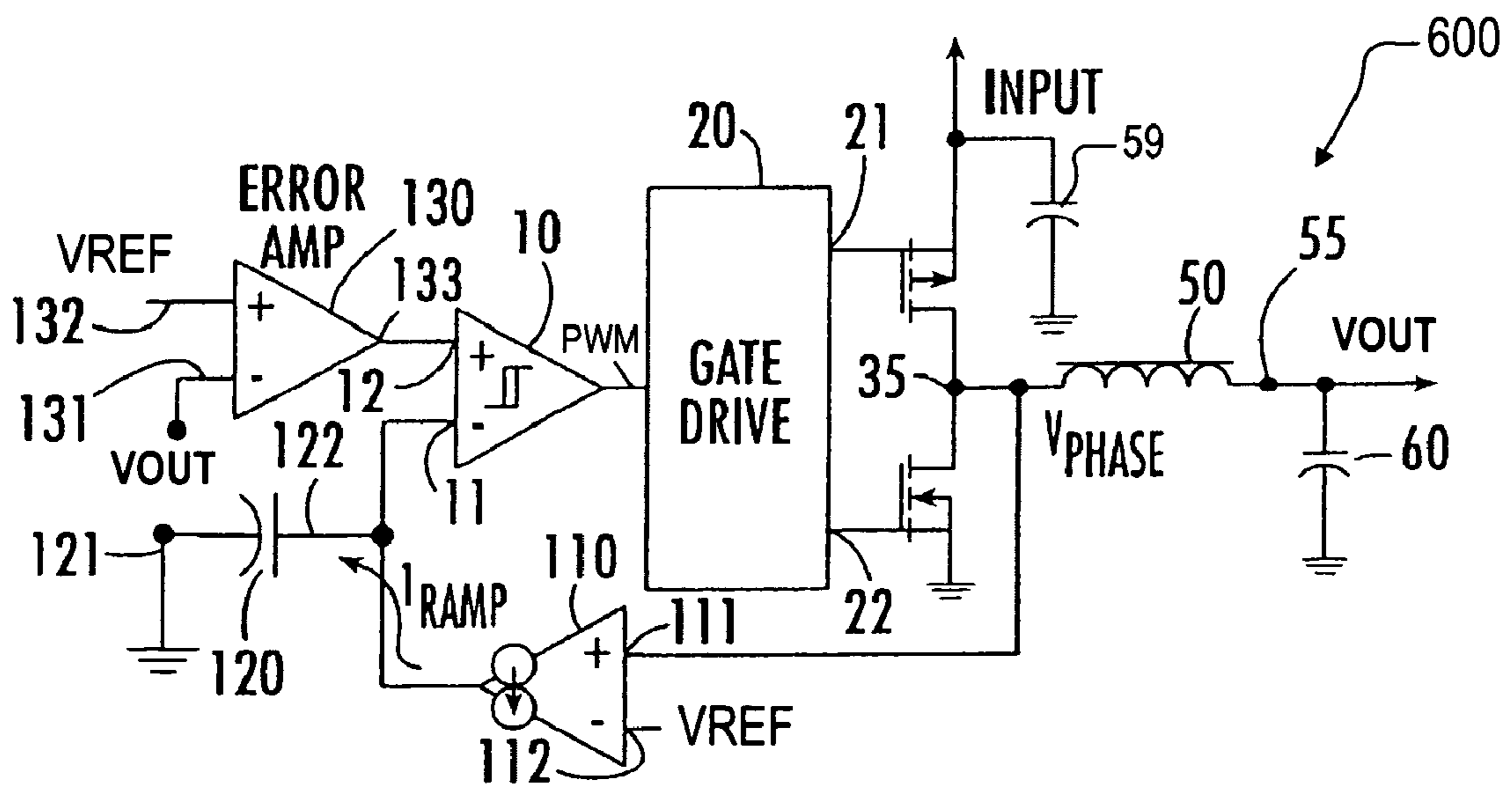

FIG. 6

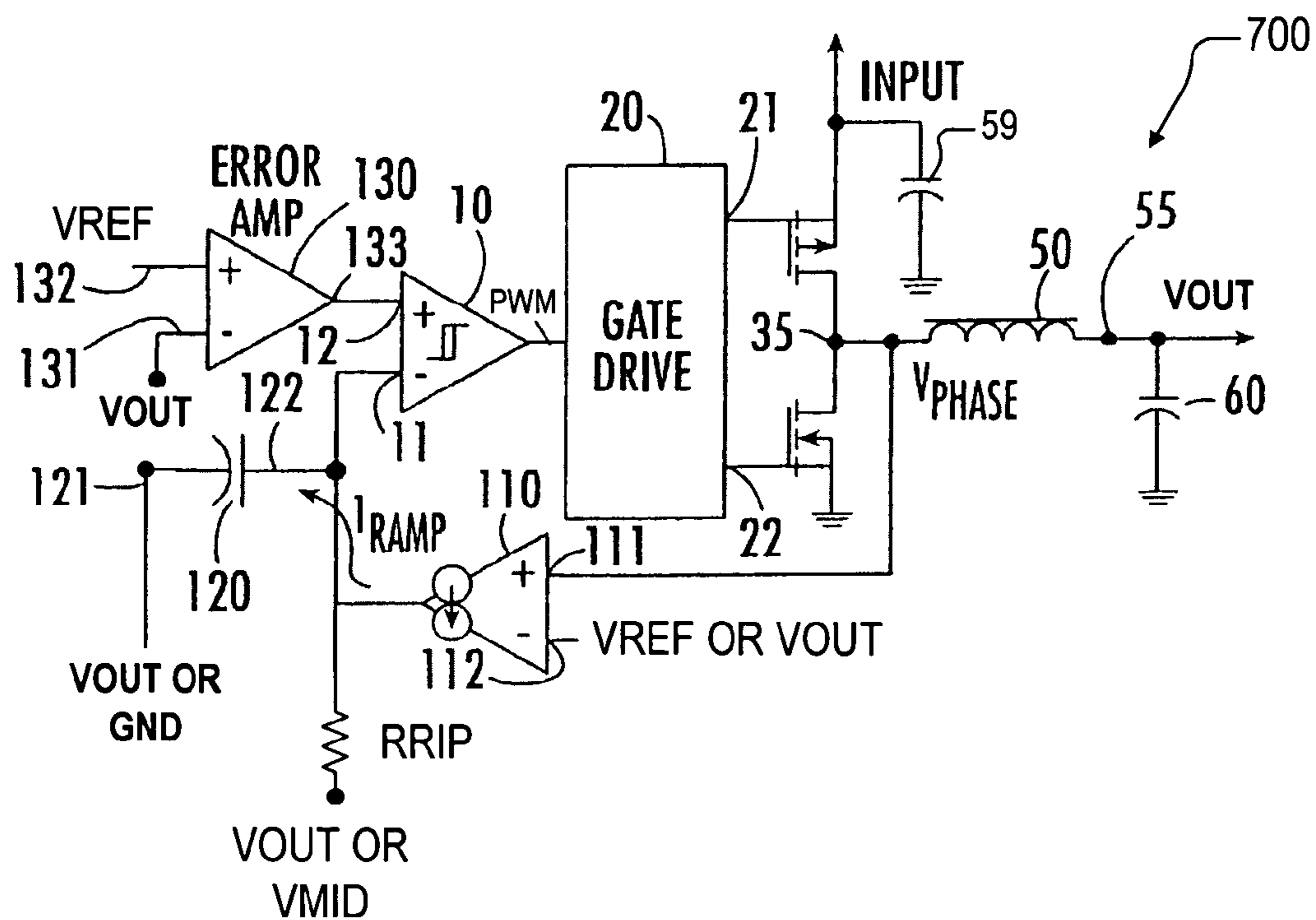

FIG. 7

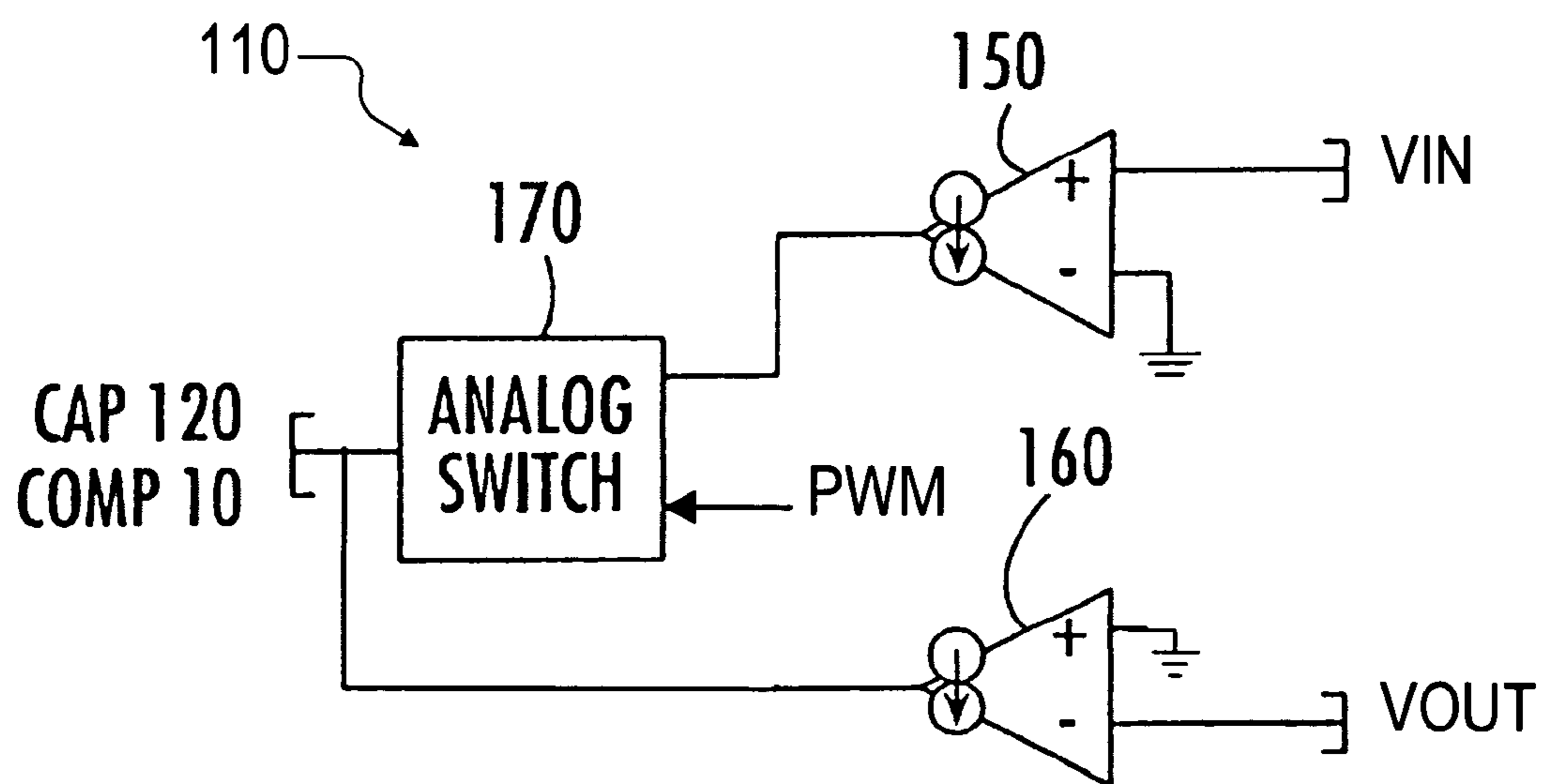

FIG. 8

SYNTHETIC RIPPLE REGULATOR

Matter enclosed in heavy brackets [] appears in the original patent but forms no part of this reissue specification; matter printed in italics indicates the additions made by reissue.

CROSS-REFERENCE TO RELATED APPLICATIONS

This application is a continuation-in-part of commonly assigned U.S. patent application Ser. No. 10/236,787, filed on Sep. 6, 2002 now U.S. Pat. No. 6,791,306, which is herein incorporated by reference for all intents and purposes.

BACKGROUND OF THE INVENTION

1. Field of the Invention

The present invention relates to powers supply circuits and related components, and is particularly directed to a DC-DC regulator including a synthetic ripple voltage generator which generates an artificial or synthesized ripple waveform that controls the switching operation of the regulator, reduces output ripple and improves DC accuracy.

2. Description of the Related Art

Electrical power for integrated circuits is typically supplied by one or more direct current (DC) power sources. In a number of applications the circuit may require multiple regulated voltages that are different from the available supply voltage (which may be relatively low e.g., on the order of a few volts or less, particularly where low current consumption is desirable, such as in portable, battery-powered devices). Moreover, in many applications the load current may vary over several orders of magnitude. To address these requirements it has been common practice to employ pulse or ripple-based regulators, such as a hysteresis or 'bang-bang' regulator.

Such a ripple-based DC-DC voltage regulator employs a relatively simple control mechanism and provides a fast response to a load transient. The switching of the ripple regulator is asynchronous, which is advantageous in applications where direct control of the switching edges is desired. For this purpose, a ripple regulator typically employs a hysteresis comparator or the like that controls a gate drive circuit coupled to the control or gate drive inputs of a pair of electronic power switching devices, such as FETs or MOSFETs or the like. The gate drive circuit controllably switches or turns the switching devices on and off in accordance with a pulse width modulation (PWM) switching waveform as known to those skilled in the art.

In such a hysteretic or 'bang-bang' regulator, the output PWM signal waveform produced by hysteresis comparator transitions to a first state (e.g., goes high) when the output voltage falls below a reference voltage minus the comparator's inherent hysteresis voltage and the comparator's PWM output transitions to a second state (e.g., goes low) when the output voltage exceeds the reference voltage plus the hysteresis voltage. The application of or increase in load causes the output voltage to decrease below the reference voltage, in response to which the comparator triggers the gate drive to turn on the upper switching device. Because the regulator is asynchronous, the gate drive control signal does not wait for a synchronizing clock, as is common in most fixed frequency PWM control schemes.

Principal concerns with this type of ripple regulator include large ripple voltage, DC voltage accuracy, and switching frequency. Since the hysteretic comparator directly

sets the magnitude of the ripple voltage, employing a smaller hysteresis voltage reduces the power conversion efficiency, as switching frequency increases with smaller hysteresis. In order to control the DC output voltage, which is a function of the ripple wave shape, the peaks and valleys of the output ripple voltage are regulated. The DC value of the output voltage is a function of the PWM duty factor. The output voltage wave shape also changes at light loads, when current through the output inductor becomes discontinuous, producing relatively short 'spikes' between which are relatively long periods of low voltage. Since the ripple voltage wave shape varies with input line and load conditions, maintaining tight DC regulation is difficult.

In addition, improvements in capacitor technology changes the ripple wave shape. In particular, the current state of ceramic capacitor technology has enabled the equivalent series resistance or ESR (which produces the piecewise linear or triangular wave shape of the output voltage waveform) of ceramic capacitors to be reduced to very low values. At very low values of ESR, however, the output voltage's ripple shape changes from triangular to a non-linear shape (e.g., parabolic and sinusoidal). This causes the output voltage to overshoot the hysteretic threshold, and results in higher peak-to-peak ripple. As a result, the very improvements that were intended to lower the output voltage ripple in DC-DC regulators can actually cause increased ripple when used in a ripple regulator.

SUMMARY OF THE INVENTION

A synthetic ripple voltage generator for a DC-DC regulator according to an exemplary embodiment of the present invention includes a transconductance amplifier circuit and a ripple capacitor. The DC-DC regulator includes a hysteretic comparator which develops a pulse width modulation (PWM) signal provided to a switching circuit that switches an input voltage via a phase node through an output inductor to develop an output voltage at an output node. The transconductance amplifier circuit has an input for coupling to the output inductor and an output coupled to the ripple capacitor and for coupling to an input of the hysteretic comparator. In this manner, the transconductance amplifier circuit monitors voltage applied to the output inductor and supplies an inductor voltage-representative current to the ripple capacitor, which produces the synthetic ripple voltage. Using the replicated inductor current for ripple regulation results in low output ripple, input voltage feed forward, and simplified compensation.

The transconductance amplifier circuit may be a single transconductance amplifier having a non-inverting input for coupling to the phase node and an inverting input for coupling to the output node or to a reference voltage. Alternatively, the transconductance amplifier circuit includes first and second transconductor amplifiers and a switch circuit. The first transconductance amplifier has an input for coupling to the output node and an output coupled to the ripple capacitor to discharge the ripple capacitor based on the output voltage. The switch circuit has an input coupled to the output of the second transconductance amplifier, an output coupled to the ripple capacitor, and a control input for receiving the PWM signal. The switch circuit is operative to couple the output of the second transconductance amplifier to charge the ripple capacitor based on the input voltage upon initiation of PWM cycles. The ripple capacitor may be referenced to ground or to the output node. A ripple resistor may be included which is coupled to the ripple capacitor to modify frequency response

3

and/or change bias voltage. The ripple resistor may be referenced to the output voltage or to a voltage source coupled in series with the ripple resistor.

A method of synthetically generating ripple voltage for a DC-DC regulator according to an embodiment of the present invention includes developing a ripple voltage indicative of current through the output inductor, and applying the ripple voltage to an input of the hysteretic comparator. The hysteretic comparator develops a PWM signal provided to a switching circuit that switches an input voltage via a phase node through an output inductor to develop an output voltage at an output node.

The developing a ripple voltage indicative of ripple current through the output inductor may include sensing voltage applied to the output inductor, converting the sensed voltage to a sense current, and charging a capacitive device with the sense current. The sensing voltage applied to the output inductor may include sensing voltage at the phase node. The method may include referencing the capacitive device to the output node or to ground. The method may include coupling a resistive device to the capacitive device. The method may include referencing the resistive device to the output node or biasing the resistive device with a voltage source.

The developing a ripple voltage indicative of ripple current through the output inductor may alternatively include converting the output voltage into a first current, discharging a capacitive device with the first current, converting the input voltage into a second current, and charging the capacitive device with the second current upon initiation of each PWM cycle using the PWM signal.

The developing a ripple voltage indicative of ripple current through the output inductor may alternatively include sensing ripple current through the output inductor and converting the sensed current into the ripple voltage.

A synthetic ripple regulator according to an exemplary embodiment of the present invention includes a hysteretic comparator, a switching circuit, an output inductor, a transconductance amplifier circuit, and a capacitor. The hysteretic comparator has an output that provides a PWM signal and the switching circuit alternately couples a phase node to opposite polarities of an input voltage source based on the PWM signal. The output inductor is coupled between the phase node and an output node that develops a regulated output signal. The transconductance amplifier circuit has an input coupled to the output inductor and an output coupled to an input of the hysteretic comparator. The capacitor is coupled to the output of the transconductance amplifier and develops a ripple voltage indicative of current through the output inductor.

The transconductance amplifier circuit may be a single transconductance amplifier having a differential input coupled across the output inductor or coupled between the phase node and a reference voltage. Alternatively, the transconductance amplifier circuit includes first and second transconductance amplifiers and a switch. The first transconductance amplifier that discharges the capacitor based on the regulated output signal. The switch couples the second transconductance amplifier to the capacitor based on the PWM signal to charge the capacitor based on input voltage during portions of PWM cycles.

BRIEF DESCRIPTION OF THE DRAWINGS

The benefits, features, and advantages of the present invention will become better understood with regard to the following description, and accompanying drawings where:

4

FIG. 1 is a schematic diagram of a synthetic ripple regulator implemented according to an exemplary embodiment of the present invention including a summation unit that adds a synthetic ripple voltage in the feedback control path;

FIG. 2 is a schematic diagram of a synthetic ripple regulator including an exemplary implementation of a synthetic ripple voltage generator including a transconductance amplifier;

FIG. 3 is a schematic diagram of a synthetic ripple regulator including another exemplary implementation of a synthetic ripple voltage generator in which the transconductance amplifier of FIG. 2 is coupled to a reference voltage;

FIG. 4 is a schematic diagram of a synthetic ripple regulator including another exemplary implementation of a synthetic ripple voltage generator including a ripple resistor and a voltage source;

FIG. 5 is a schematic diagram of a synthetic ripple regulator including another exemplary implementation of a synthetic ripple voltage generator including a ripple resistor referenced to the output voltage;

FIG. 6 is a schematic diagram of a synthetic ripple regulator including another exemplary implementation of a synthetic ripple voltage generator in which the ripple capacitor is referenced to a common reference voltage;

FIG. 7 is a schematic diagram of another synthetic ripple regulator illustrating that any one or more of the variations of the regulators of FIGS. 2-6 may be applied in any combination as appreciated by those of ordinary skill in the art

FIG. 8 is a schematic and block diagram illustrating an alternative embodiment of the transconductance amplifier of FIGS. 2-7 including two transconductance amplifiers generating current based on the input and output voltages, respectively.

DETAILED DESCRIPTION

The following description is presented to enable one of ordinary skill in the art to make and use the present invention as provided within the context of a particular application and its requirements. Various modifications to the preferred embodiment will, however, be apparent to one skilled in the art, and the general principles defined herein may be applied to other embodiments. Therefore, the present invention is not intended to be limited to the particular embodiments shown and described herein, but is to be accorded the widest scope consistent with the principles and novel features herein disclosed.

FIG. 1 is a schematic diagram of a synthetic ripple regulator **100** implemented according to an exemplary embodiment of the present invention including a summation unit **101** that adds a synthetic ripple voltage VRIP in the feedback control path. The synthetic ripple regulator **100** employs a hysteresis comparator **10** that controls a gate drive circuit **20** with respective output drive ports **21** and **22**. The drive ports **21** and **22** are coupled to the control or gate drive inputs of a pair of electronic power switching devices, respectively shown as an upper P-MOSFET (or PFET) device **30** and a lower N-MOSFET (or NFET) device **40**. The switching devices **30** and **40** have their drain-source paths coupled in series between first and second reference voltages, such as an input voltage VIN and ground (GIN). An input filter capacitor **59** is coupled between VIN and GIN. The gate drive circuit **20** controllably switches or turns the two switching devices **30** and **40** on and off in accordance with a pulse width modulation (PWM) switching waveform supplied by comparator **10**. The upper switching device **30** is turned on and off by an upper gate switching signal UG applied by the gate driver **20** and the

switching device **40** is turned on and off by a lower gate switching signal LG applied by the gate driver **20**.

A common or phase voltage node **35** between the two switching devices **30** and **40** develops a phase voltage VPHASE and is coupled to one end of an output inductor **50**, having its other end coupled to an output node **55** developing an output signal VOUT. The output node **55** is coupled to an output capacitor **60** referenced to a prescribed reference potential, such as GIN. The output node **55** is coupled to an input of the summation unit **101**, which receives an auxiliary ripple voltage VRIP at its other input. The summation unit **101** adds VRIP to VOUT in the feedback path and provides the result to the inverting (−) input **11** of the hysteretic comparator **10**. The output node **55** is further coupled to the inverting (−) input **131** of an error amplifier **130**. The error amplifier **130** has its non-inverting (+) input **132** coupled to receive a DC reference voltage VREF, and has its output **133** coupled to the non-inverting (+) input **12** of hysteresis comparator **10**. In the illustrated embodiments, VREF has a voltage representative of the voltage of VOUT under little or no load conditions. The error amplifier **130** serves to increase the DC regulation accuracy, providing high DC gain to reduce errors due to ripple wave shape, various offsets, and other errors. The error amplifier **130** operates as an integrator that generates an error reference voltage provided to the non-inverting input **12** of hysteresis comparator **10**.

The summation unit **101** injects the auxiliary ripple voltage VRIP into the feedback path to input **11** of the hysteretic comparator **10**, so as to be combined with the VOUT signal at node **55**. VRIP may be generated by many methods, including an independent, clock-generated signal sufficient to provide the desired regulation of the regulator **100**. In one embodiment, VRIP is synchronized to the switching intervals of the regulator **100** and has a shape corresponding to, or otherwise indicative of, the inductor current I_L through the output inductor **50**. The inductor current I_L includes a ripple current, which, in the present example, is a triangular wave shaped ripple current. The inductor current I_L may also include a DC component. Many methods are known for sensing the current I_L through the output inductor **50** and converting the sensed current into a proportional voltage for generating the VRIP signal, such as a current sensor and current to voltage converter. In one embodiment, VRIP is proportional to I_L including its AC and DC components. Alternatively, VRIP follows only the output inductor ripple current without the DC component of I_L . In any event, VRIP is, or otherwise incorporates, a ripple voltage indicative of the ripple current through the output inductor **50**. VRIP may also include a separate DC or offset voltage component in the various embodiments.

It is noted that the ripple portion of the inductor current I_L through the inductor **50** is related to, but not the same as, the output voltage ripple of the VOUT signal at node **55**. The output voltage ripple depends on many factors, including, for example, the type and configuration of the output capacitor **60**. If the capacitor **60** is a ceramic capacitor, for example, the output ripple voltage may be very low especially in low-load conditions, which would otherwise cause regulation difficulty at the comparator **10**. The comparator **10** operates best with a ripple voltage having a sufficient magnitude relative to the hysteresis voltage difference of the comparator **10** and which has relatively clean or sharp transitions (e.g., peaks and valleys). Synthetically generating the ripple voltage VRIP based on I_L and adding to the feedback loop of the comparator **10** provides a ripple signal suitable for regulation and that is naturally synchronized to the switching intervals of the regulator **100**.

FIG. 2 is a schematic diagram of a synthetic ripple regulator **200** including an exemplary implementation of a synthetic ripple voltage generator including a transconductance amplifier **110**. Similar components as those for the regulator **100** are shown with the same reference numbers. The output of the transconductance amplifier **110** is coupled to one terminal **122** of a ripple capacitor **120** and to the inverting input **11** of the comparator **10**. The transconductance amplifier **110** has its non-inverting (+) input **111** coupled to the phase node **35** and its inverting (−) input **112** coupled to the output voltage node **55**. The output node **55** is further coupled to another terminal **121** of the capacitor **120** and to the inverting (−) input **131** of the error amplifier **130**.

In this manner, the transconductance amplifier **110** produces an output current I_{RAMP} based on or otherwise proportional to the voltage across the inductor **50**. The ripple voltage capacitor **120** transforms the I_{RAMP} current into an inductor current-representative voltage having the desired waveform shape. At least one benefit of synthesizing the ripple waveform based on the inductor current I_L is the inherent feed-forward characteristic. For a step input voltage change of V_{IN} , the current I_{RAMP} changes accordingly to modify the conduction interval of the power switching devices **30** and **40**. As described in the prior disclosure, the ripple voltage generated across the ripple voltage capacitor **120** is substantially similar in form and frequency with the current through inductor **50**. The amount of ripple at the output is relatively small during large load current transients, which also causes corresponding changes in switching frequency as described in the prior disclosure.

FIG. 3 is a schematic diagram of a synthetic ripple regulator **300** including another exemplary implementation of a synthetic ripple voltage generator in which the transconductance amplifier **110** receiving the reference voltage VREF. Similar components as those for the regulators **100** and **200** are shown with the same reference numbers. The regulator **300** is substantially similar to the regulator **200** except that the inverting input **112** of the transconductance amplifier **110** is coupled to VREF instead of VOUT. The connection to VOUT in the regulator **200** results in relatively fast feedback in response to changes in VOUT which may be unstable in certain configurations. VREF is constant and does not change so that the VOUT feedback response characteristic at the input of transconductance amplifier **110** is eliminated for the regulator **300**.

FIG. 4 is a schematic diagram of a synthetic ripple regulator **400** including another exemplary implementation of a synthetic ripple voltage generator including a ripple resistor and a voltage supply **401**. The regulator **400** is substantially similar to the regulator **300** in which similar components assume the same reference numbers. In this case, a ripple resistor RRIP has one end coupled to the output of the transconductance amplifier **110** and another end coupled to the positive terminal of the voltage source **401**, having its negative terminal coupled to GIN. The voltage source **401** develops a mid-supply voltage VMID. The voltage of VMID is based on the supply voltage for digital logic. In one embodiment, for example, the supply voltage is 5V and VMID is approximately 1.5V. The voltage across the inductor **50** includes a DC voltage level, due at least in part to its inherent DCR, which otherwise continuously charges the capacitor **120** so that its voltage rises over time. The resistor RRIP provides compensation or otherwise modifies frequency response by discharging the capacitor **120** at the appropriate rate to prevent charge build-up. Also, in certain embodiments, the DC voltage on the capacitor may go too high and/or too low, so that it is biased to the mid-supply voltage VMID via

the relatively large resistor RRIP. The RC time constant of the ripple capacitor **120** and the resistor RRIP creates a “zero” in the transfer function of the regulator **400**. The effect of the zero is taken into account when selecting the specific component values to make the regulation loop stable.

FIG. **5** is a schematic diagram of a synthetic ripple regulator **500** including another exemplary implementation of a synthetic ripple voltage generator including the ripple resistor RRIP referenced to VOUT. The regulator **500** is substantially similar to the regulator **400** in which similar components assume the same reference numbers. In this case, RRIP is provided and coupled between the output of the transconductance amplifier **110** and VOUT. The ripple resistor RRIP provides a similar function as previously described. Compensation is potentially improved when referencing RRIP to VOUT in certain configurations.

FIG. **6** is a schematic diagram of a synthetic ripple regulator **600** including another exemplary implementation of a synthetic ripple voltage generator in which the ripple capacitor **120** is referenced to a common reference voltage (e.g., GIN). The regulator **600** is substantially similar to the regulator **300** in which similar components assume the same reference numbers. In this case, the terminal **121** of the capacitor **120** is coupled to a common reference voltage, such as GIN, rather than to VOUT. The regulator **600** provides additional stability by eliminating the almost immediate feedback connection to VOUT, at the cost of reduced responsiveness to step transitions of VOUT.

FIG. **7** is a schematic diagram of a synthetic ripple regulator **700** illustrating that any one or more of the variations of the regulators **200-600** may be applied in any combination as appreciated by those of ordinary skill in the art. Again, similar components assume identical reference numbers. As illustrated, the inverting input of the transconductance amplifier **110** is either coupled to VREF or VOUT, the terminal **121** of the capacitor **120** is either coupled to VOUT or GIN, and the optional resistor RRIP is referenced to either VOUT or VMID. Thus, any combination of the described variations is contemplated.

FIG. **8** is a schematic and block diagram illustrating an alternative embodiment of the transconductance amplifier **110**. In this case, the functionality of transconductance amplifier **110** is implemented as two independently controlled transconductance amplifiers **150** and **160** and an analog switch **170** receiving the PWM signal. As illustrated, the transconductance amplifier **150** has its non-inverting input receiving VIN and its inverting input coupled to GIN, while the transconductance amplifier **160** has its inverting input receiving VOUT and its non-inverting input coupled to GND. The output of the amplifier **150** is selectively switched through the analog switch **170** to capacitor **120** and the inverting (−) input **11** of the hysteretic comparator **10**. This alternative configuration allows the ramp current to be more precisely controlled for improved linearity.

In operation, the transconductance amplifier **160** continuously discharges the capacitor **120** at a rate based on the voltage level of VOUT and the transconductance amplifier **150** charges the capacitor **120** at a rate based on VIN when coupled to the capacitor **120** via the analog switch **170**. In the simplified embodiment illustrated, the analog switch **170** is responsive to the PWM signal to couple the output of the transconductance amplifier **150** to the capacitor **120** at the beginning of the PWM cycle when the PWM signal is asserted high. Since VIN is typically significantly larger than VOUT and since the analog switch **170** switches relatively quickly, the capacitor **120** is quickly charged without the potential delays otherwise associated with the phase node **35**.

The analog switch **170** decouples the transconductance amplifier **150** from the capacitor **120** in response to PWM going low.

Although the present invention has been described in considerable detail with reference to certain preferred versions thereof, other versions and variations are possible and contemplated. Those skilled in the art should appreciate that they can readily use the disclosed conception and specific embodiments as a basis for designing or modifying other structures for providing out the same purposes of the present invention without departing from the spirit and scope of the invention as defined by the following claim(s).

The invention claimed is:

1. A synthetic ripple voltage generator for a DC-DC regulator having a hysteretic comparator that develops a pulse width modulation (PWM) signal provided to a switching circuit that switches an input voltage via a phase node through an output inductor to develop an output voltage at an output node, said synthetic ripple voltage generator comprising:

a transconductance amplifier circuit having an input for coupling to the output inductor and an output for coupling to an input of the hysteretic comparator; and a ripple capacitor coupled to said output of said transconductance amplifier circuit;

wherein said transconductance amplifier circuit provides current to said ripple capacitor which develops a voltage indicative of ripple current through the output inductor.

2. The synthetic ripple voltage generator of claim **1**, wherein said transconductance amplifier circuit comprises a transconductance amplifier having a non-inverting input for coupling to the phase node and an inverting input for coupling to the output node.

3. The synthetic ripple voltage generator of claim **1**, wherein said transconductance amplifier circuit comprises a transconductance amplifier having a non-inverting input for coupling to the phase node and an inverting input for coupling to a reference voltage.

4. The synthetic ripple voltage generator of claim **1**, wherein said ripple capacitor has a first end coupled to said output of said transconductance amplifier circuit and a second end for coupling to the output node.

5. The synthetic ripple voltage generator of claim **1**, wherein said ripple capacitor has a first end coupled to said output of said transconductance amplifier circuit and a second end coupled to ground.

6. The synthetic ripple voltage generator of claim **1**, further comprising a ripple resistor coupled to said ripple capacitor.

7. The synthetic ripple voltage generator of claim **6**, further comprising:

a voltage source referenced to ground; and said ripple resistor having a first end coupled to said ripple capacitor and a second end coupled to said voltage source.

8. The synthetic ripple voltage generator of claim **6**, wherein said ripple resistor has a first end coupled to said ripple capacitor and a second end for coupling to the output node.

9. The synthetic ripple voltage generator of claim **1**, wherein said transconductance amplifier circuit comprises:

a first transconductance amplifier having an input for coupling to the output node and an output coupled to said ripple capacitor to discharge said ripple capacitor based on the output voltage;

a second transconductance amplifier having an input for receiving the input voltage and an output; and

a switch circuit, having an input coupled to said output of said second transconductance amplifier, an output

coupled to said ripple capacitor, and a control input for receiving the PWM signal, said switch circuit operative to couple said output of said second transconductance amplifier to said ripple capacitor to charge said ripple capacitor based on the input voltage upon initiation of PWM cycles.

10. A method of synthetically generating ripple voltage for a DC-DC regulator including a hysteretic comparator that develops a pulse width modulation (PWM) signal provided to a switching circuit that switches an input voltage via a phase node through an output inductor to develop an output voltage at an output node, said method comprising:

developing a ripple voltage indicative of current through the output inductor; and
applying the ripple voltage to an input of the hysteretic comparator.

11. The method of claim 10, wherein said developing a ripple voltage indicative of current through the output inductor comprises:

sensing voltage applied to the output inductor;
converting the sensed voltage to a sense current; and
charging a capacitive device with the sense current.

12. The method of claim 11, wherein said sensing voltage applied to the output inductor comprises sensing voltage at the phase node.

13. The method of claim 11, further comprising referencing the capacitive device to the output node.

14. The method of claim 11, further comprising referencing the capacitive device to ground.

15. The method of claim 11, further comprising coupling a resistive device to the capacitive device.

16. The method of claim 15, further comprising referencing the resistive device to the output node.

17. The method of claim 15, further comprising biasing the resistive device with a voltage source.

18. The method of claim 10, wherein said developing a ripple voltage indicative of current through the output inductor comprises:

converting the output voltage into a first current;
discharging a capacitive device with the first current;
converting the input voltage into a second current; and
charging the capacitive device with the second current upon initiation of each PWM cycle using the PWM signal.

19. The method of claim 10, wherein said developing a ripple voltage indicative of ripple current through the output inductor comprises:

sensing ripple current through the output inductor, and
converting sensed current into the ripple voltage.

20. A synthetic ripple regulator, comprising:

a hysteretic comparator having a first input and having an output that provides a pulse width modulation (PWM) signal;

a switching circuit that alternately couples a phase node to opposite polarities of an input voltage source based on said PWM signal;

an output inductor coupled between said phase node and an output node that develops a regulated output signal;

a transconductance amplifier circuit having an input coupled to said output inductor and an output coupled to said first input of said hysteretic comparator; and

a capacitor, coupled to said output of said transconductance amplifier circuit, that develops a ripple voltage indicative of ripple current through said output inductor.

21. The synthetic ripple regulator of claim 20, further comprising an error amplifier having a first input receiving a

reference voltage, a second input coupled to said output node, and an output coupled to a second input of said hysteretic comparator.

22. The synthetic ripple regulator of claim 20, wherein said transconductance amplifier circuit comprises a transconductance amplifier having a first input coupled to said phase node and a second input coupled to said output node.

23. The synthetic ripple regulator of claim 20, wherein said transconductance amplifier circuit comprises a transconductance amplifier having a first input coupled to said phase node and a second input coupled to a reference voltage.

24. The synthetic ripple regulator of claim 20, wherein said capacitor has a first end coupled to said output of said transconductance amplifier circuit and a second end coupled to said output node.

25. The synthetic ripple regulator of claim 20, wherein said capacitor has a first end coupled to said output of said transconductance amplifier circuit and a second end coupled to ground.

26. The synthetic ripple regulator of claim 20, further comprising:

a resistive device having a first end coupled to said output of said transconductance amplifier circuit and a second end; and

a voltage source coupled between said second end of said resistive device and ground.

27. The synthetic ripple regulator of claim 20, further comprising a resistive device having a first end coupled to said output of said transconductance amplifier circuit and a second end coupled to said output node.

28. The synthetic ripple regulator of claim 20, wherein said transconductance amplifier circuit comprises:

a first transconductance amplifier having an input coupled to said output node and an output coupled to said capacitor to discharge said capacitor based on said regulated output signal;

a second transconductance amplifier having an input coupled to said input voltage source and an output; and

a switch that couples said output of said second transconductance amplifier to said capacitor based on said PWM signal to charge said capacitor based on input voltage during portions of PWM cycles.

29. A synthetic ripple voltage generator for a DC-DC regulator having a hysteretic comparator that develops a pulse width modulation signal provided to a switching circuit that controls switching of voltage across an output inductor which is coupled to an output node developing an output voltage, said synthetic ripple voltage generator comprising:

a transconductance amplifier circuit having an input for coupling to the output inductor and an output for coupling to an input of the hysteretic comparator; and
a ripple capacitor coupled to said output of said transconductance amplifier circuit;

wherein said transconductance amplifier circuit provides current to said ripple capacitor which develops a voltage indicative of ripple current through the output inductor.

30. The synthetic ripple voltage generator of claim 29, wherein said transconductance amplifier circuit comprises a transconductance amplifier having a pair of inputs for coupling across the output inductor.

31. The synthetic ripple voltage generator of claim 29, wherein said ripple capacitor has a first end coupled to said output of said transconductance amplifier circuit and a second end for coupling to either one of the output node and ground.

11

32. The synthetic ripple voltage generator of claim 29, further comprising a ripple resistor having one end coupled to said ripple capacitor and another end coupled to either one of the output node and a voltage source providing a constant voltage level.

33. A method of synthetically generating ripple voltage for a DC-DC regulator including a hysteretic comparator that develops a pulse width modulation signal provided to a switching circuit that controls switching of voltage applied to an output inductor coupled to an output node which develops an output voltage, said method comprising: developing a ripple voltage indicative of current through the output inductor; and applying the ripple voltage to an input of the hysteretic comparator.

34. The method of claim 33, wherein said developing a ripple voltage indicative of current through the output inductor comprises: sensing voltage applied to the output inductor;

12

converting the sensed voltage to a sense current; and charging a capacitive device with the sense current.

35. The method of claim 33, wherein said sensing voltage applied to the output inductor comprises sensing voltage at the input node.

36. The method of claim 33, wherein said sensing voltage applied to the output inductor comprises sensing voltage across the output inductor.

37. The method of claim 33, further comprising coupling a resistive device to the capacitive device.

38. The method of claim 37, wherein said developing a ripple voltage indicative of ripple current through the output inductor comprises: sensing ripple current through the output inductor; and converting sensed current into the ripple voltage.

* * * * *