

US00RE43362E

(19) **United States**
(12) **Reissued Patent**
Yerazunis et al.

(10) **Patent Number:** **US RE43,362 E**
(45) **Date of Reissued Patent:** **May 8, 2012**

(54) **PRIVACY-ENHANCED DISPLAY DEVICE**
(75) Inventors: **William S. Yerazunis**, Acton, MA (US);
Darren L. Leigh, Round Hill, VA (US);
Marco S. Carbone, Brooklyn, NY (US)
(73) Assignee: **Binary Services Limited Liability**
Company, Wilmington, DE (US)
(21) Appl. No.: **12/354,415**
(22) Filed: **Jan. 15, 2009**

5,063,602 A 11/1991 Peppers et al.
5,117,302 A 5/1992 Lipton
5,181,133 A 1/1993 Lipton
5,463,428 A 10/1995 Lipton et al.
5,488,492 A 1/1996 Abe
5,528,319 A 6/1996 Austin
5,583,674 A 12/1996 Mosley
5,629,984 A 5/1997 McManis
5,717,412 A 2/1998 Edwards
5,963,371 A 10/1999 Needham et al.
5,991,426 A 11/1999 Cox et al.
6,018,331 A 1/2000 Ogawa
6,128,049 A 10/2000 Butterworth
6,421,109 B1 7/2002 Popovich
6,456,432 B1 * 9/2002 Lazzaro et al. 359/464
6,597,328 B1 7/2003 Stern et al.
6,661,425 B1 12/2003 Hiroaki
6,784,887 B1 * 8/2004 Tourai 345/501

Related U.S. Patent Documents

Reissue of:

(64) Patent No.: **7,164,779**
Issued: **Jan. 16, 2007**
Appl. No.: **09/923,107**
Filed: **Aug. 6, 2001**

(51) **Int. Cl.**
G06K 9/00 (2006.01)
G09G 5/00 (2006.01)
G09G 5/10 (2006.01)
G06K 9/74 (2006.01)
G06K 9/20 (2006.01)
G06K 9/36 (2006.01)
(52) **U.S. Cl.** **382/100; 359/464; 359/465; 348/43;**
348/53; 348/56; 345/629; 345/634; 345/690;
382/213; 382/214; 382/283
(58) **Field of Classification Search** **382/100,**
382/213, 214, 283; 359/464-465; 348/43,
348/53, 56; 345/629, 634, 690
See application file for complete search history.

(56) **References Cited**

U.S. PATENT DOCUMENTS

4,870,486 A * 9/1989 Nakagawa et al. 349/15
4,967,268 A 10/1990 Lipton et al.

OTHER PUBLICATIONS

InvisiView Technologies. www.man-machine.com/invisivw.html.
Jul. 19, 2001.
Alfred Poor, "InvisiView Makes your Notebook Snoop-Proof"; PC
Magazine Online, Jul. 19, 2001.

* cited by examiner

Primary Examiner — Wesley Tucker
(74) *Attorney, Agent, or Firm* — Woodcock Washburn LLP

(57) **ABSTRACT**
A method displays an image only to an authorized user by generating a mask image from a data image. The data and mask image are then displayed periodically in an alternating manner on a display device by a select signal. The opening end shutting of an optical shutter device is synchronized to the displaying of the selected images so that only the data image is perceived by the authorized user viewing the display device through the optical shutter device, and a gray image is perceived by an unauthorized user viewing the data and mask images directly.

33 Claims, 4 Drawing Sheets

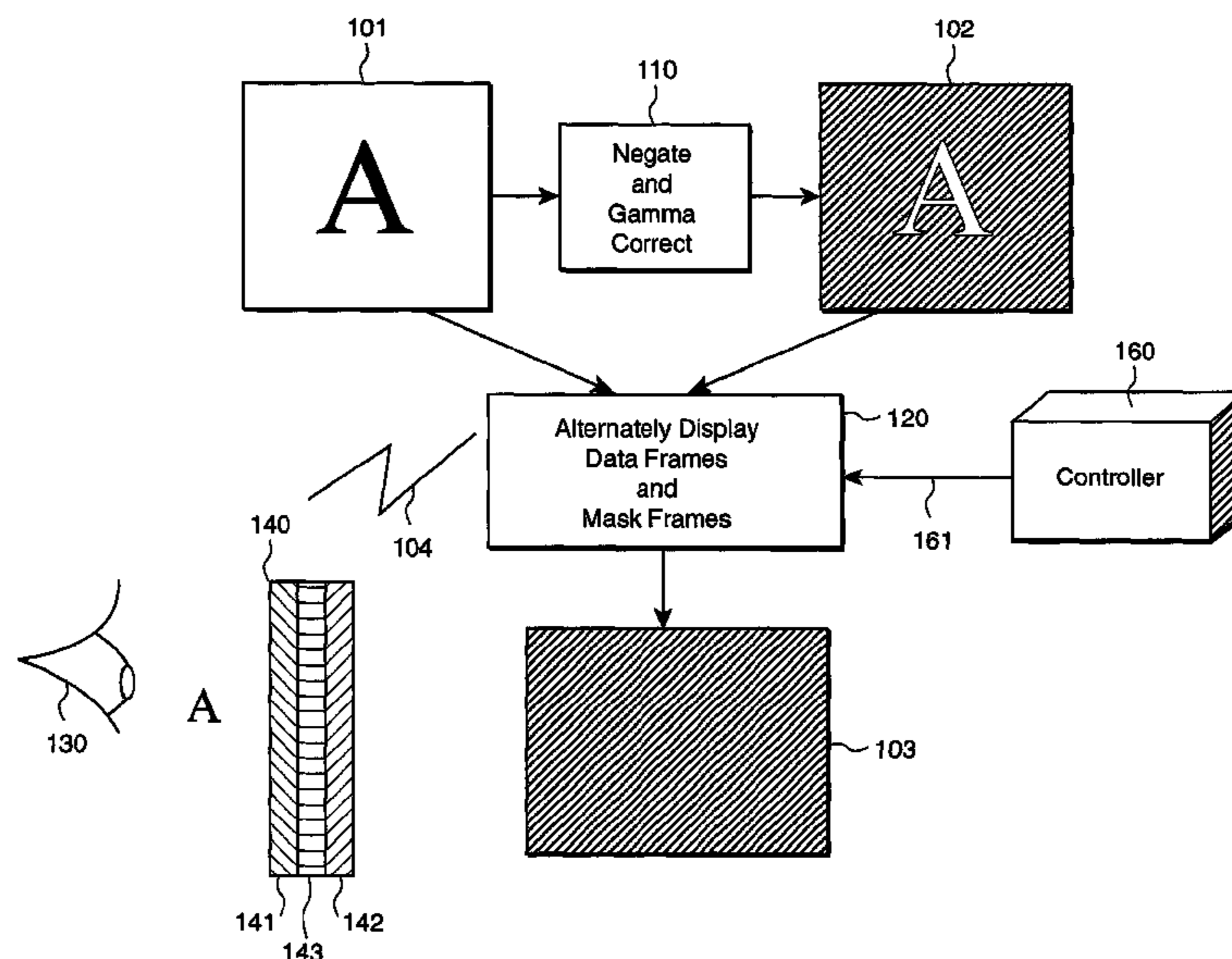

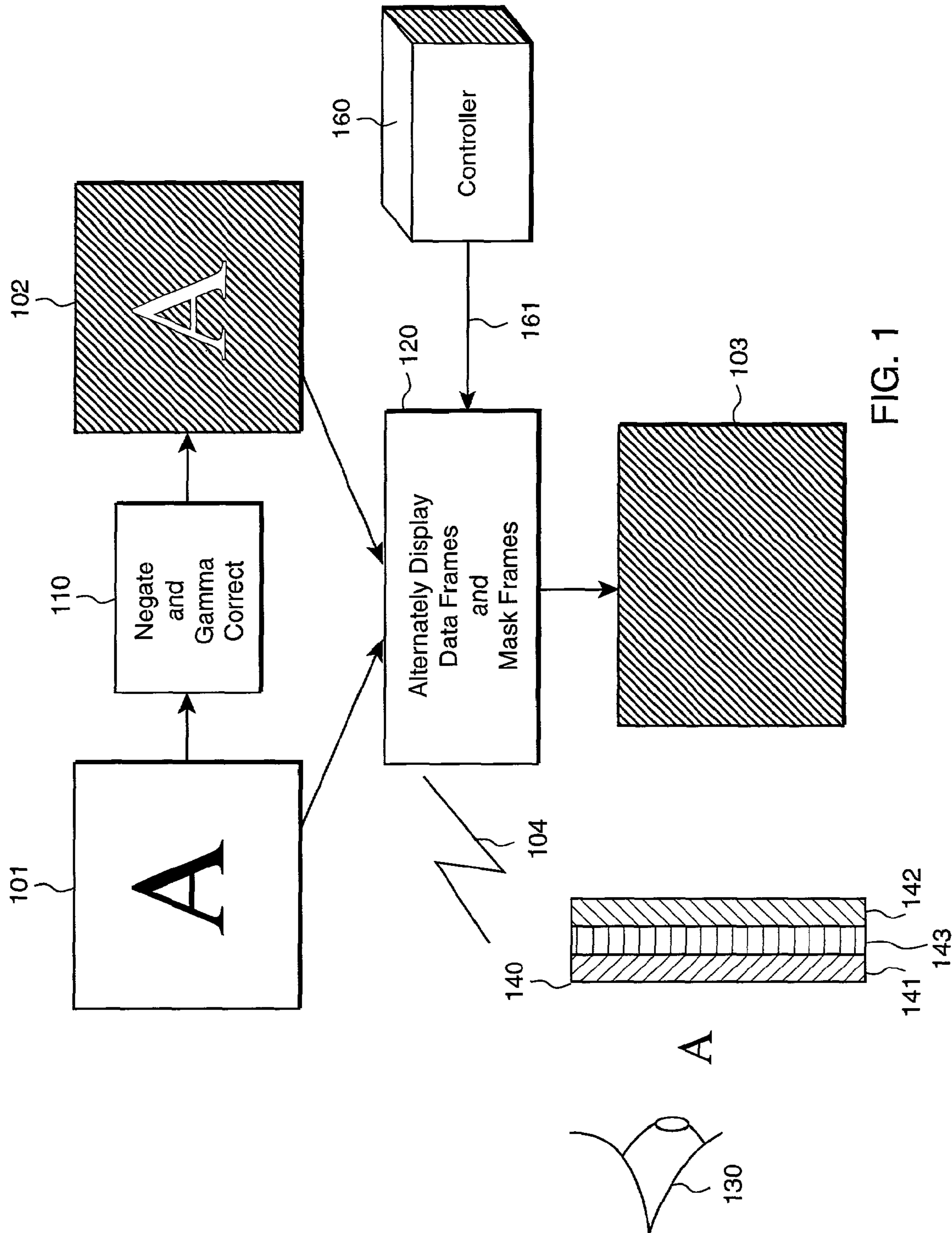

FIG. 1

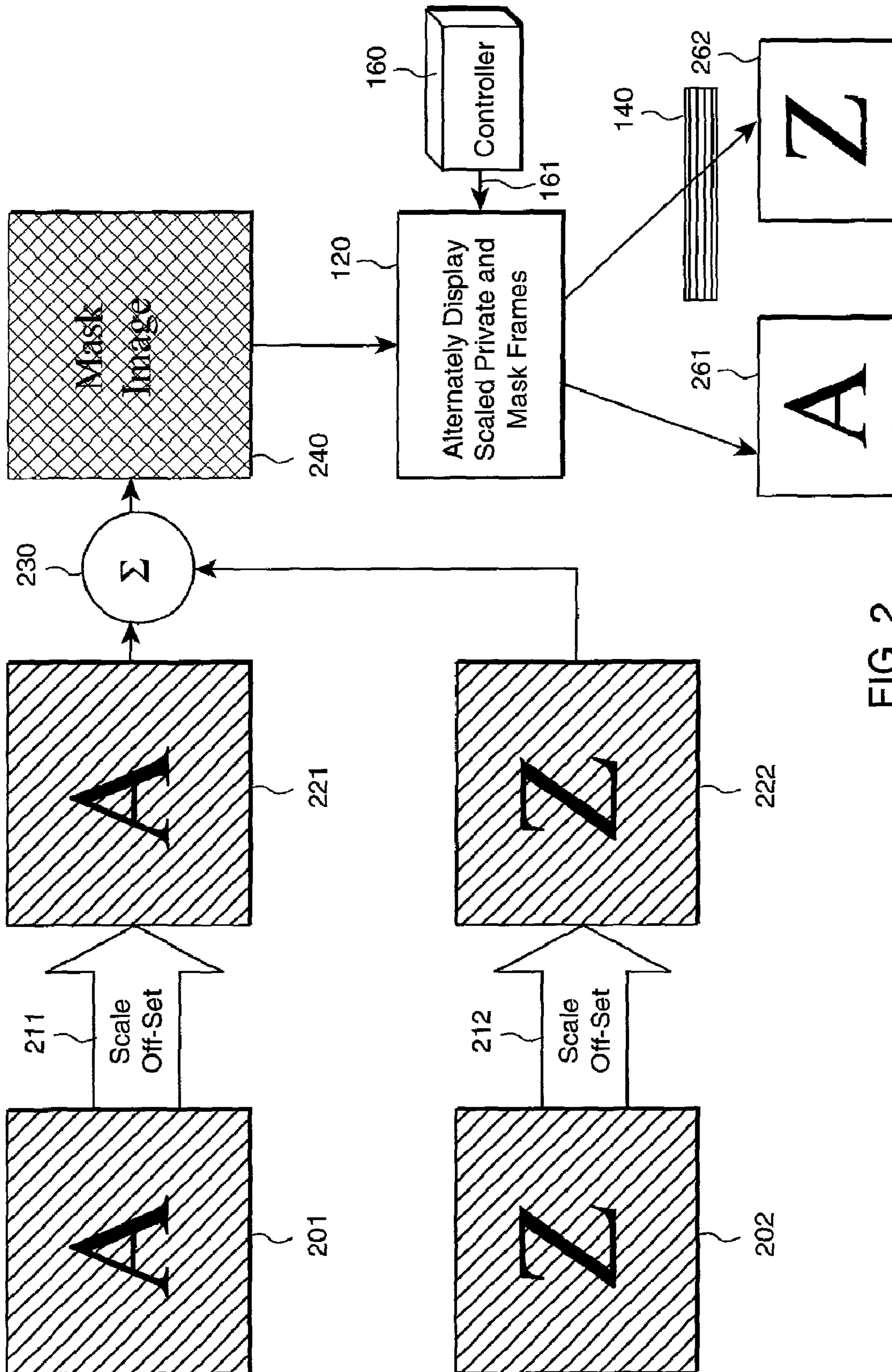

FIG. 2

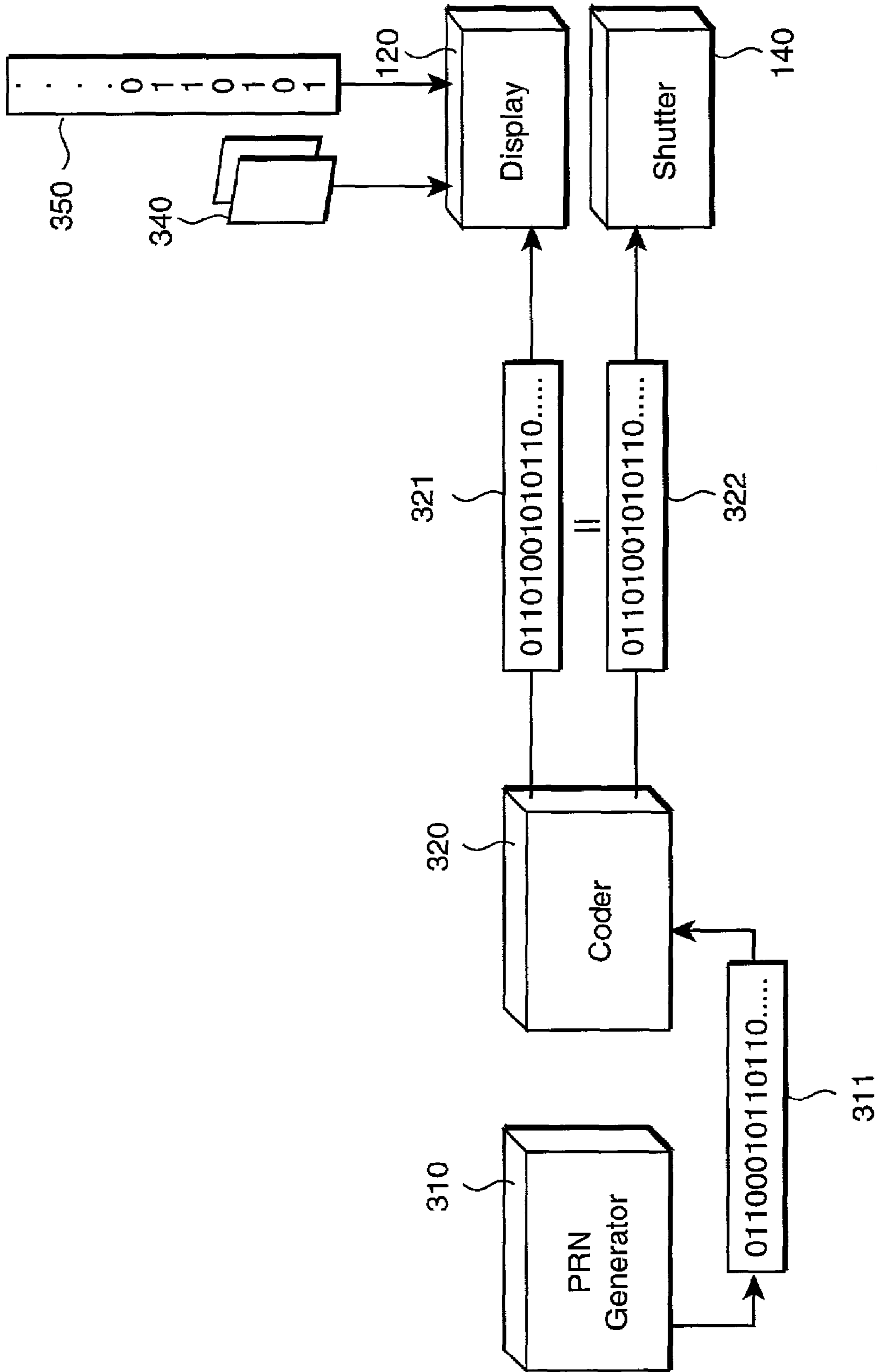

FIG. 3

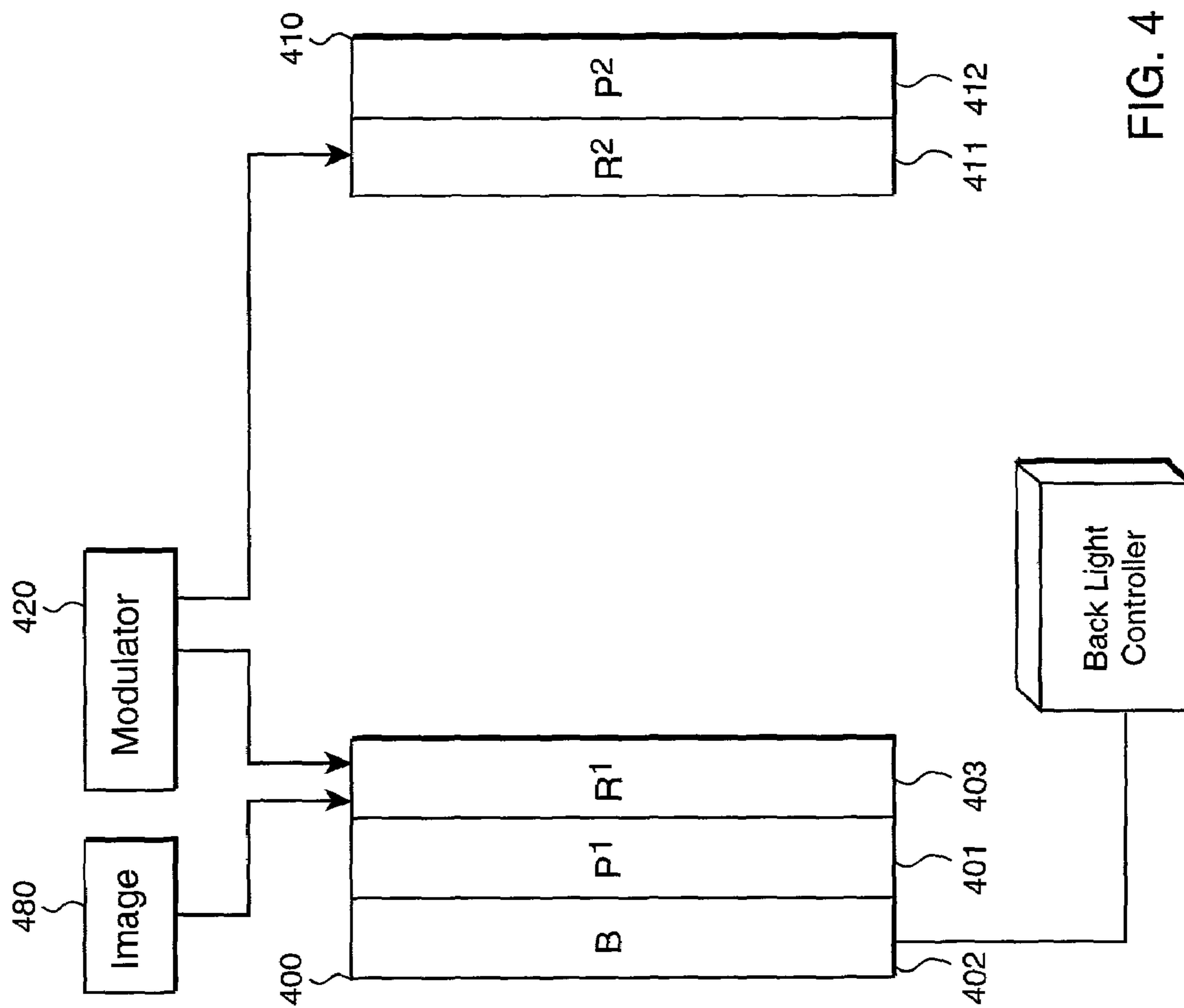

FIG. 4

PRIVACY-ENHANCED DISPLAY DEVICE

Matter enclosed in heavy brackets [] appears in the original patent but forms no part of this reissue specification; matter printed in italics indicates the additions made by reissue.

FIELD OF THE INVENTION

The present invention relates generally to the field of data security, and more particularly to displaying secure data on display devices in public locations.

BACKGROUND OF THE INVENTION

With the advent of desktop and portable computer systems, the problem of maintaining the confidentiality of secure data is increased. This is a particular problem for laptop computers and hand-held personal digital assistants (PDAs) that are frequently used in public locations. Data security is also a problem for other display systems, such as automated teller machines, and Internet terminals in public locations, such as Internet shops and airports.

In recent years, a great deal of effort has been expended on making flat panel display screens as readable as CRT screens by using active matrix technology. However, enhanced readability of displayed data increases the risk of confidential information being viewable by unauthorized persons when portable displays are used in public locations.

One solution is to provide the display with physical "blind-ers" mounted on the side of the display to limit the angle at which the display can be seen. Another type of mechanical solution uses microscopic louvers to obscure the screen to any viewer not along the axis of the louvers. However, this does not prevent viewing by a person sitting directly behind the user of the display. In addition, this type of arrangement does not allow the user to leave the equipment unattended.

One manufacturer, InvisiView Technologies, Inc., Boca Raton, Fla., removes the front polarizer from a LCD type of device so the displayed image is no longer visible. If the display is viewed through polarized lenses, it becomes visible. This is a partial solution because anyone wearing consumer-grade polarized sunglasses can defeat the system.

U.S. Pat. No. 5,528,319 "Privacy filter for a display device" issued to Austin on Jun. 18, 1996 describes a privacy filter constructed of spaced-apart opaque grids that can be fitted to a display device. The problems with this arrangement is that it requires physical modification of the device, and like the blinders above, only limits the angle at which the display can be viewed.

U.S. Pat. No. 5,629,984 "System and method for data security" issued to McManis on May 13, 1997 describes a display system that alternates data frames with flash frames where an overwhelming majority of pixels are illuminated so that the flash frames have an average intensity substantially greater than the data frames. The user views the display with a shutter device that is synchronized to the displayed frames. The shutter is open for the data frames, and closed for the flash frames. The interspersed flash frames are intended to make it difficult for a viewer without the optical shutter device to intelligibly read the data frames.

The problem with this system is that most people can perceive images even is the relative intensity of darkest elements is only about $1/100$ that of the brightest elements. In other words, the intensity of the flash frames would have to be increased by at least 20 db in order for the device to be

effective. In a practical LCD applications, the display elements are usually driven at full power to maximize brightness. Therefore, it is problematic whether the driving voltage can be increased by a factor of a hundred. Even if the flash frames can be displayed, it is well known that over illuminating the display screen greatly shortens its useable life-span. In addition, the flash frames would attract attention to bystanders, and the device is more susceptible to counter attacks.

SUMMARY OF THE INVENTION

The invention provides a method for displaying an image only to an authorized user by generating a mask image from a data image. The data and mask image are then displayed periodically in an alternating manner on a display device by a select signal. The opening and shutting of an optical shutter device is synchronized to the displaying of the selected images so that only the data image is perceived by the authorized user viewing the display device through the optical shutter device, and a gray image is perceived by an unauthorized user viewing the data and mask images directly. Alternatively, the displaying and operation of the optical shutter device can be in a random order that is only known to the display device and the shutter. In another alternative, the displaying and operation of the optical shutter device is done on a per pixel basis, either randomly or periodically.

BRIEF DESCRIPTION OF THE DRAWINGS

FIG. 1 is flow diagram of a privacy enhanced display system according to the invention;

FIG. 2 is a flow diagram of a secure display according to the invention;

FIG. 3 is a flow diagram of an encoded display according to the invention; and

FIG. 4 is a flow diagram of an alternative embodiment of a secure display system.

DETAILED DESCRIPTION OF THE PREFERRED EMBODIMENT

System Overview

Movies, televisions and computerized display devices normally display frames at a predetermined frame rate, e.g., twenty-four per second or higher. Persistence in the human visual system causes the rapidly displayed frames to merge into a continuous image. In the present invention, this persistence is used to enable privacy-enhanced display devices.

As shown in FIG. 1, input to the system is a data frame **101**, or perhaps a sequence of data frames as in a video. Each data frame, in sequential order, is negated **110** to produce a mask (reverse) frame **102**. The negation can be done by an inverter. A display device **120** then selectively displays either the data frame or the mask frame **102**. The selection is done according to a select signal **161** generated by a controller **160**. In one embodiment, the controller **160** produces a clock signal that alternatively selects either the data frame or the negative frame.

The net result is a featureless neutral "gray" image **103** because the overall perceived intensity of the image is half-way between sum of the intensities of the data and mask frames. Thus, privacy of the displayed information is preserved. It should be understood that frames of a video can be similarly be processed in sequence.

A user **130** perceives only the data frames **101** by viewing the neutral images **103** through a shutter device **140** that is synchronized **104** in phase and frequency to the frame rate of

the display device **120**. Frequency synchronization can be done internally to the optical shutter device **140**. The shutter device **140** is open for the data frames **101** and closed for the mask frames **102** so that only the phase needs to be synchronized.

One type of shutter device can use modified CrystalEyes™ eyewear manufactured by StereoGraphics Corporation of San Rafael, Calif. and described in U.S. Pat. Nos. 44,967,268, 5,117,302, 5,181,133, and 5,463,428 incorporated herein by reference. The unmodified glasses operate the left and right lenses sequentially for stereoscopic viewing, the modified lenses operate in parallel.

However, nematic liquid-crystal stereographic shutter glasses are typically limited to an operating frequency of 60 Hz, or less. This leads to noticeable flickering in the perceived image. Therefore, our shutter device **140** includes polarizing lenses **141-142** on either side of a ferro-electric liquid crystal (FLC) polarization rotator **143**. The FLC rotator can switch polarization rotation from $+\pi/4$ to $-\pi/4$ at a frequency up to about 100 KHz, when driven by a bipolar ± 5.0 volt control line **144** to take advantage of faster displays.

Wire or wireless, e.g., infra-red, communication can be used to synchronize to the phase of the display device **120**. This allows the display device according to the invention to be used concurrently by multiple users in a public location without requiring a physical link between the users and the display device.

For safety and ease-of-use reasons, the optical shutter device **140** operates continuously while worn by the user so that the user's environment remains visible even if the user is not in range of the display unit. Thus, the synchronization signal **104** only needs to control the phase, and not the frequency or amplitude, of the select signal **161**.

If the data frames **101** are binary or two-tone image, then a negation simply means turning all white components of the data frames, e.g., pixels with zero or off values, to black components in the negative frames, e.g. pixels with one or on values. If the data frame use a gray scale, then the negation simply subtracts the pixel values of the data frames from the maximum pixel value, i.e., 255 for an eight bit pixel value.

Although a primary use of the invention is with portable display devices, it should be noted that the display system as described above can use any number of illumination techniques including CRT, LCD, LED, laser, digital projector—rear- or front, large or small, and so forth.

Color Display

In the case of color images, the negation is performed independently on each of the color channels, e.g., red, green, and blue for a "RGB" display system. Thus, for a system that display each of red, green, and blue at 256 levels, such as commonly available 24-bit (3×8) color mode display devices, each pixel of the red negative frame is displayed at a value of 255 minus the corresponding red data frame pixel value. Similarly, the values for the green and blue channels are determined.

The intensity of the light generated by most display devices is usually not a linear function of the applied signal. A conventional CRT has a power-law response to voltage. Therefore, the intensity of the light produced at the face of the screen of the display is approximately the applied voltage, raised to the 2.2 power. The numerical value of the exponent of this power function is colloquially known as gamma (γ). This non-linearity must be compensated for in the negated frames.

To do this correction for a typical CRT type of display device, the input pixel values from 0 to 255, after negation, are remapped to output pixel values according to

$$\text{output} = 255((\text{input}/255)^{1/\gamma}) + 0.5$$

where γ is obtained from the display device CRT manufacturer's specifications.

Secure Display

FIG. 2 shows an alternative embodiment the input is a public image **201** and a secret image **102**. The intensity values of the images **201-202** are respectively scaled and off-set **211-212** to produce a scaled public image A **221** and a scaled secret image Z **222**. For every pixel p_p in the public image **201**, $\alpha p_p + A$, and the secret pixels are $\beta p_s + B$. The scaled images **221-222** are then combined **230** to produce a mask image **240**. The mask image **240** and scaled secret image **222** are then displayed **120** according to the select signal **161** produced by the controller **160**, as described above. The result is that without the optical shutter device **140**, the perceived image **261** is the scaled public image **221**. However, when the display device **120** is viewed through the optical shutter device **140**, the perceived image **262** is the scaled secret image **222**.

The scaling and off-setting are such that the intensity values of the mask image **240** are within the dynamic range of the display device. If the normalized dynamic range of the display device is 0 to 1, and the respective scaling factors are α and β , and the off-sets A and B, then $\alpha + \beta \leq 1$, and $\alpha + A \leq B$. These inequalities constrain the respective dynamic ranges of the perceived public image **261** and the perceived secret images **262**. A high-dynamic-range public image forces a low-dynamic-range, dim perceived secret image, and vice versa. If $\alpha = \beta$, and $A = 0.0$ and $B = 0.5$, the perceived public and secret images will be of equal quality. The perceived public image will lower in contrast with an elevated black level, and the perceived secret image will be dimmer, but still within a brightness range for acceptable viewing.

Coded Display

The above described display devices provide a reasonable level of privacy for the casual user. However, because the displayed images alternate at a constant frequency, e.g., 60 Hz, the system is still open to attack by a persistent snooper. By scanning through the frequency range, a snooper could determined the frequency of the alternating display.

FIG. 3 shows an embodiment where a pseudo random (PR) generator **310** is used to generate a pseudo random sequence of zero and one bits **311**. The random sequence can be produced by a hash function that uses a seed value, half of which is stored internally, and the other half is supplied in real-time, perhaps at the frame rate. The PR generator **310** can be incorporated into the controller **160** instead of a constant frequency clock.

In the case of a wireless interconnection, two pseudo-random generators can be used. Each is initialized to the same state and so will produce the same random sequence. One sequence is used in the display device, and the other in the optical shutter device. Synchronization between the sequences can be done as described above.

A coder **320** converts each zero bit to a pair of select signals **[0,1]**, and each one bit to a pair of select signals **[1,0]**. The resulting coding sequences **321-322** are fed, in parallel, to the display device **120** and a shutter device **140** to perform the appropriate selection of the order of displayed images. Note, the pairs in the select signals **321** and **322** ensure that each successive pair of input frames **340** will alternate, so the perceived effect will be as above, with the added advantage that it is impossible for a snooper to determine the random sequence **311**, without direct access to the equipment.

Serial Coding

So far, we have assumed that pixels are displayed and perceived in a parallel manner. This is effectively true for most LCD and CRT devices. Even though the pixels are

5

initially generated in a serial beam and displayed in a raster scan order on a CRT, the relatively long decay time of the physical display elements, e.g., phosphor dots, parallelizes the perceived illumination. Consequently, the optical shutter device can operate at the frame rate of the display device.

For a device where the pixels can truly be displayed in a serial manner, e.g., LEDs, FLCs, or laser displays, we can modify the above encoding technique to further enhance the security of the displayed images.

In this embodiment, the input image is in the form of a serial stream of pixel values **350**, e.g., zeroes and ones for a binary image or byte values for gray-scale and color images. Now, we modulate the pixels and shutter on a per pixel basis. For every zero value in the coding sequence **321** we display the correct pixel value, and for every one bit in the coding sequence, we negate the pixel value, as described above with reference to FIG. 1. Similarly, the opening and closing of the optical shutter device **140** is on a pixel basis, with the optical shutters closed for negated pixel values. Thus, some one viewing the display synchronized to the frame rate of the images will still only perceive a gray image.

LCD Display

In the case where the display device **120** uses a low-powered liquid crystal display (LCD), such as used with many portable display systems, additional enhancement can be made, as shown in FIG. 4, for the following reasons. First, a LCD cannot change state as quickly as CRT type of display devices, therefore perceived persistence may be an issue. Second, LCDs are generally low-power, aggravating the degradation of the perceived images.

Therefore, our LCD **400** is constructed as follows. A first polarizer (P^1) **401** is disposed between a backlight (B) **420** and a first optical rotator element (R^1) **430**. The backlight is a source of incident light of mixed polarization. We omit the customary other polarizer found in conventional LCDs. In this embodiment, the optical shutter device **440** includes a second optical rotator element (R^2) **411** and a second polarizer (P^2) **412**. An input image **400** is modulated **420** by angle of polarization. The modulation can be regular or random as described above.

If the image is viewed by the unaided eye, then it appears uniformly white. If the image is viewed through standard polarizing lenses, as for the prior art InvisiView device, it is still unreadable. However, when the image is viewed through the optical shutter device **410** modulated synchronously to the image **400**, the image will become visible.

The modulation of the rotators can be done adding $\pm 45^\circ$ off-set to the normal polarization modulation. This can be done by biasing the overall screen voltage, because in the LCD, the amount of rotation is substantially linearly proportional to the driving voltage. As described above, the modulation of the rotators can be done periodically or randomly, depending on the level of security desired.

Thus, areas of the image that appear bright in one polarization direction appear dark in a perpendicular direction, and these are reverse whenever the $+45$ to -45 degree rotational voltage modulation occurs. The result is as before, the screen appears a featureless gray to unauthorized viewers, even those wearing polarizing sunglasses, and only properly modulated shutter devices will make the image **400** visible.

This invention is described using specific terms and examples. It is to be understood that various other adaptations and modifications may be made within the spirit and scope of the invention. Therefore, it is the object of the appended claims to cover all such variations and modifications as come within the true spirit and scope of the invention.

6

What is claimed is:

1. A method for displaying [an] a data image only to an authorized user, comprising:

[generating a data image;]

generating a mask image, from pixels of the data image, wherein the mask image is a negation of the pixels of the data image;

generating automatically a select signal with a controller; selecting alternately the data image or the mask image according to the select signal; and

sequentially displaying the selected images on a display device to merge the data image and the mask image into a perceived continuous image to provide a perceived gray image to an unauthorized user while displaying the data image only to an authorized user.

2. The method of claim 1 further comprising:

opening an optical shutter device, according to the select signal, when the data image is displayed;

shutting the optical shutter device, according to the select signal, when the mask image is displayed so that only the data image is perceived by the authorized user viewing the display device through the optical shutter device, and the gray image is perceived by the unauthorized user viewing the data and mask images directly, the opening and shutting synchronized in phase and frequency to the select signal.

3. The method of claim 2 wherein the optical shutter device includes a polarizing lens on either side of a ferroelectric liquid crystal polarization rotator.

4. The method of claim 2 further comprising:

synchronizing the displaying, and the opening and shutting by a wire link.

5. The method of claim 2 further comprising:

synchronizing the displaying, and the opening and shutting by a wireless link.

6. The method of claim 5 wherein the synchronization is according to a phase of the select signal.

7. The method of claim 2 further comprising:

generating a first random select signal to select the displayed images;

generating a second random select signal to open and shut the optical shutter device; and

synchronizing the second random select signal to the first random select signal.

8. The method of claim 1 wherein each image is a color image, and the negation is done independently for each color channel of the color image.

9. The method of claim 8 further comprising:

gamma-correcting each color channel after the negation.

10. The method of claim 8 wherein each input pixel of each color image has an intensity in a range from 0 to 255, and each output pixel is determined by:

$$\text{output} = 255((\text{input}/255)^{1/\gamma}) + 0.5.$$

11. The method of claim 1 wherein the select signal is generated by a clock, and further comprising: alternately selecting the data and mask images according to clock cycles.

12. The method of claim 1 wherein the select signal is generated by a random generator of the controller.

13. The method of claim 12 wherein the displayed images occur in pairs so that each pair includes a first image and a second image in a random order.

14. The method of claim 12 wherein the random generator operates according to an internal seed value and a real-time supplied value.

7

15. The method of claim 1 wherein [each] *the* data image includes a plurality of pixels, and further comprising: negating each pixel of the data image serially to generate each corresponding pixel of the mask image; and serially selecting each pixel of the data image or the mask image according to [a] *the* select signal; and sequentially displaying the selected pixels on [a] *the* display device.

16. The method of claim 15 further comprising: opening an optical shutter device when the selected pixel of the data image is displayed; shutting the optical shutter device when the selected pixel of the mask image is displayed so that only the data image is perceived by the authorized user viewing the display device through the optical shutter device, and a gray image is perceived by the unauthorized user viewing the data and mask images directly, the opening and shutting synchronized in phase and frequency to the select signal.

17. The method of claim 16 wherein the select signal is generated by a clock, and further comprising: alternately selecting the pixel from the data *image* and the pixel from the mask [images] *image* according to clock cycles of the controller.

18. The method of claim 1 wherein the select signal is generated by a random generator of the controller.

19. The method of claim 1 wherein a plurality of data images are provided in a video, and each data image is sequentially negated to produce the corresponding mask image.

20. An apparatus for displaying [an] *a* data image only to an authorized user, comprising:

[a video camera generating a data image;]
an inverter for generating a mask image from pixels of the data image, wherein the mask image is a negation of the pixels of the data image;

a controller generating automatically a select signal for selecting alternately the data image or the mask image; and

a display device for sequentially displaying selected images as a merged perceived continuous image on [a] *the* display device to [produce] *provide* a perceived gray image [and] *to an unauthorized user* while displaying the data image only to an authorized user.

21. The apparatus of claim 20 further comprising: an optical shutter device *that is* opened when the data image is displayed and closed when the mask image is displayed so that only the data image is perceived by the authorized user viewing the display device through the optical shutter device, and a gray image is perceived by the unauthorized user viewing the data and mask images directly, the opening and shutting of the optical shutter device synchronized in phase and frequency to the select signal.

22. The apparatus of claim 20 wherein the data and mask images are selected periodically by the automatically generated select signal.

23. The apparatus of claim 20 wherein the data and mask images are selected randomly.

8

24. The apparatus of claim 20 wherein each image includes a plurality of pixels, and wherein each pixel of the data image is negated serially.

25. *The apparatus of claim 20 further comprising a video camera operable to generate the data image.*

26. *A method for displaying a data image only to an authorized user, comprising:*

emitting a backlight through at least one polarizer and an optical rotator element to project said data image outwardly from a display; and

automatically controlling a modulation of an angle of polarization of the projected data image by controlling said optical rotator element, wherein a substantially uniformly solid color is perceived when viewing the projected data image with an unaided eye and wherein the projected data image is viewable through an optical shutter modulated substantially synchronously with the modulation of the angle of polarization of the projected data image.

27. *The method as recited in claim 26 wherein the automatically controlling a modulation of the angle of polarization is performed at least in part by the optical rotator element offsetting a polarization angle by substantially 45°.*

28. *The method as recited in claim 26 wherein the automatically controlling a modulation of the angle of polarization is random.*

29. *An apparatus for displaying a data image only to an authorized user, comprising:*

a backlight;

an optical rotator element disposed in front of a polarizer, the optical rotator element modulating an angle of polarization of the data image;

the polarizer positioned between said backlight and said optical rotator element, such that light from the backlight passes through the polarizer and the optical rotator element to project the data image outwardly; and

a controller configured to automatically control the modulation of the angle of polarization by the optical rotator element such that a substantially uniformly solid color is perceived by an unaided eye.

30. *The apparatus as recited in claim 29, further comprising:*

an optical shutter device comprising a second optical rotator element;

a second polarizer disposed proximate said second optical rotator element; and

a second controller configured to automatically control a modulation of the angle of polarization by the second optical rotator element, such that said data image is viewable through said optical shutter device.

31. *The apparatus as recited in claim 30 wherein the second controller controls the modulation of the angle of polarization to offset the angle of polarization by substantially 45°.*

32. *The apparatus as recited in claim 30 wherein the modulation is random.*

33. *The method as recited in claim 26 wherein the uniformly solid color is white.*

* * * * *

UNITED STATES PATENT AND TRADEMARK OFFICE
CERTIFICATE OF CORRECTION

PATENT NO. : RE43,362 E
APPLICATION NO. : 12/354415
DATED : May 8, 2012
INVENTOR(S) : Yerazunis et al.

Page 1 of 1

It is certified that error appears in the above-identified patent and that said Letters Patent is hereby corrected as shown below:

In Column 2, Line 30, delete “is” and insert -- is a --, therefor.

In Column 3, Line 8, delete “44,967,268,” and insert -- 4,967,268, --, therefor.

In Column 3, Line 19, delete “ $-\pi/4$ ” and insert -- $\pi/4$ --, therefor.

In Column 4, Line 39, delete “determined” and insert -- determine --, therefor.

In Column 6, Line 10, in Claim 1, delete “the” and insert -- [a] *the* --, therefor.

Signed and Sealed this
Twenty-third Day of October, 2012



David J. Kappos
Director of the United States Patent and Trademark Office