

US00RE43340E

(19) **United States**  
(12) **Reissued Patent**  
Heinz et al.

(10) **Patent Number:** **US RE43,340 E**  
(45) **Date of Reissued Patent:** **May 1, 2012**

(54) **METHOD FOR OPERATING AN ETHERNET OPTICAL AREA NETWORK (“EOAN”) OVER ONE OR MORE METROPOLITAN AREAS**

FOREIGN PATENT DOCUMENTS  
EP 335562 \* 10/1989  
(Continued)

(75) Inventors: **Patrick Heinz**, Burnsville, MN (US);  
**Christopher Scheper**, New Miami, OH (US); **David Leary**, Cincinnati, OH (US)

OTHER PUBLICATIONS

“Building New-Generation Metropolitan Area Networks”, White Paper, Extreme Networks, 2000.\*

(73) Assignee: **511 Technologies, Inc.**, Marshall, TX (US)

(Continued)

(21) Appl. No.: **12/806,733**

Primary Examiner — Leslie Pascal

(22) Filed: **Aug. 19, 2010**

(74) Attorney, Agent, or Firm — Loudermilk & Associates

**Related U.S. Patent Documents**

Reissue of:

(64) Patent No.: **7,415,209**  
Issued: **Aug. 19, 2008**  
Appl. No.: **11/656,340**  
Filed: **Jan. 22, 2007**

U.S. Applications:

(63) Continuation of application No. 10/001,524, filed on Oct. 24, 2001, now Pat. No. 7,167,648.

(51) **Int. Cl.**  
**H04B 10/20** (2006.01)  
**H04J 14/00** (2006.01)  
**H04L 12/28** (2006.01)

(52) **U.S. Cl.** ..... **398/58; 398/59; 370/404**

(58) **Field of Classification Search** ..... 398/46,  
398/58–59, 66, 71–72, 78–79, 82, 118, 177;  
370/404

See application file for complete search history.

(56) **References Cited**

**U.S. PATENT DOCUMENTS**

4,063,220 A \* 12/1977 Metcalfe et al. .... 370/462  
5,050,164 A \* 9/1991 Chao et al. .... 398/67

(Continued)

(57) **ABSTRACT**

An Ethernet Optical Area Network (EOAN) system, and methods for implementing and using such an EOAN system, are disclosed. The EOAN system may be used to improve the speed and reliability of data communications networks for small to medium-sized companies in metropolitan area networks. The EOAN system provides end-to-end Ethernet protocol, enabling professionals to have high-speed data communications in real time. The EOAN system may be generally utilized for improving data communications between branch offices, home offices, campuses, and remote sites for a wide variety of industries. The present invention preferably includes a fiber optic ring, Network Operation Center (NOC), NOC architecture components, existing client equipment, and one or more Free Space Optic (FSO) devices, microwave communication technology, and/or data switching platforms to implement high-speed Ethernet-based connections such as within a specified metropolitan area. The preferred EOAN system preferably integrates a plurality of FSO, microwave, and/or fiber optic technologies with Ethernet protocol (Fast Ethernet, Gigabit Ethernet, 10 Gigabit, etc.) to provide data connection services.

**41 Claims, 10 Drawing Sheets**

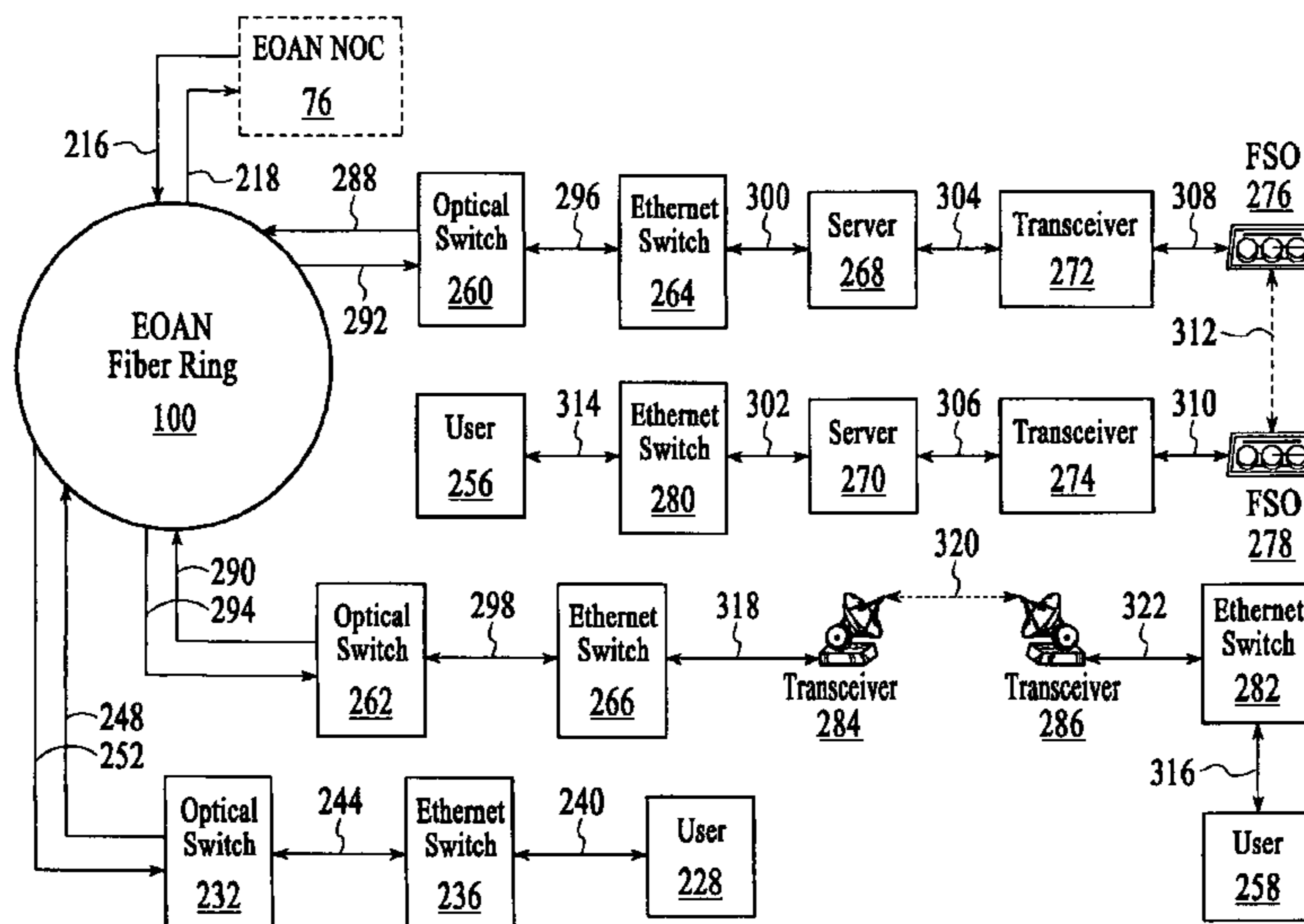

# US RE43,340 E

Page 2

## U.S. PATENT DOCUMENTS

5,247,381	A *	9/1993	Olmstead et al. ....	398/58
5,647,035	A *	7/1997	Cadeddu et al. ....	385/24
6,067,179	A *	5/2000	Roberts et al. ....	398/97
6,104,700	A *	8/2000	Haddock et al. ....	370/235
6,185,023	B1 *	2/2001	Mizrahi .....	398/9
6,198,556	B1 *	3/2001	Mizrahi .....	398/85
6,359,729	B1 *	3/2002	Amoruso .....	359/341.1
6,359,882	B1 *	3/2002	Robles et al. ....	370/389
6,366,584	B1 *	4/2002	Gulliford et al. ....	370/403
2002/0013858	A1 *	1/2002	Anderson .....	709/245
2002/0191250	A1 *	12/2002	Graves et al. ....	359/128

## FOREIGN PATENT DOCUMENTS

WO	9810566	*	3/1998
WO	9962224	*	12/1999
WO	WO 0004660		1/2000
WO	WO 0124134		4/2001
WO	0004660	*	1/2009
WO	0124134	*	4/2011

## OTHER PUBLICATIONS

“Fiber Optic Infrastructure”, Wite Paper, ExtremeNetworks, 2000.\*  
Held, Gilbert, “Understanding Data Communication”, 6th Edition, Indianapolis; New Riders, 1999, Ch. 7, pp. 263-286 and Ch. 11, pp. 414-427.\*  
IEEE;Standards for Local and Metropolitan Area Networks Overview and Architecture; Dec. 31, 1990.\*  
“Policy Based Quality of Service for Service Providers”, White Paper, Extreme Networks, 2000.\*  
Ramswami, R. et al, “Optical Networks: A Practice Perspective”, New York, Morgan Kaufman Publishers, 1998.\*  
IEEE: Standard for Local and Metropolitan Area Networks: Overview and Architecture, Dec. 31, 1990.  
Ramaswami, R. and Kumar N. Sivarajan, “Optical Networks: A Practical Perspective”, New York, Morgan Kaufmann Publishers, 1998.

\* cited by examiner

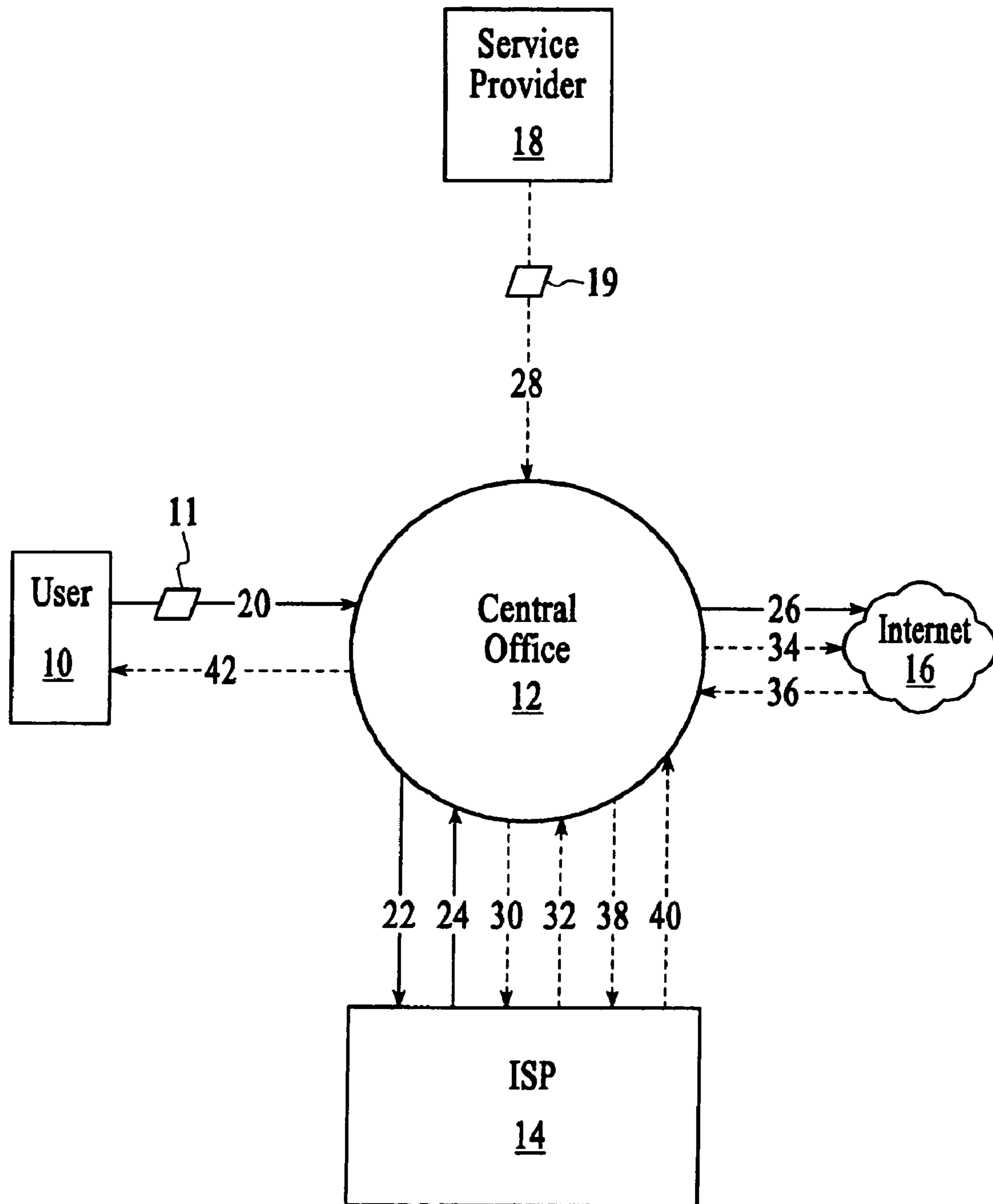

**FIG. 1A**  
(PRIOR ART)

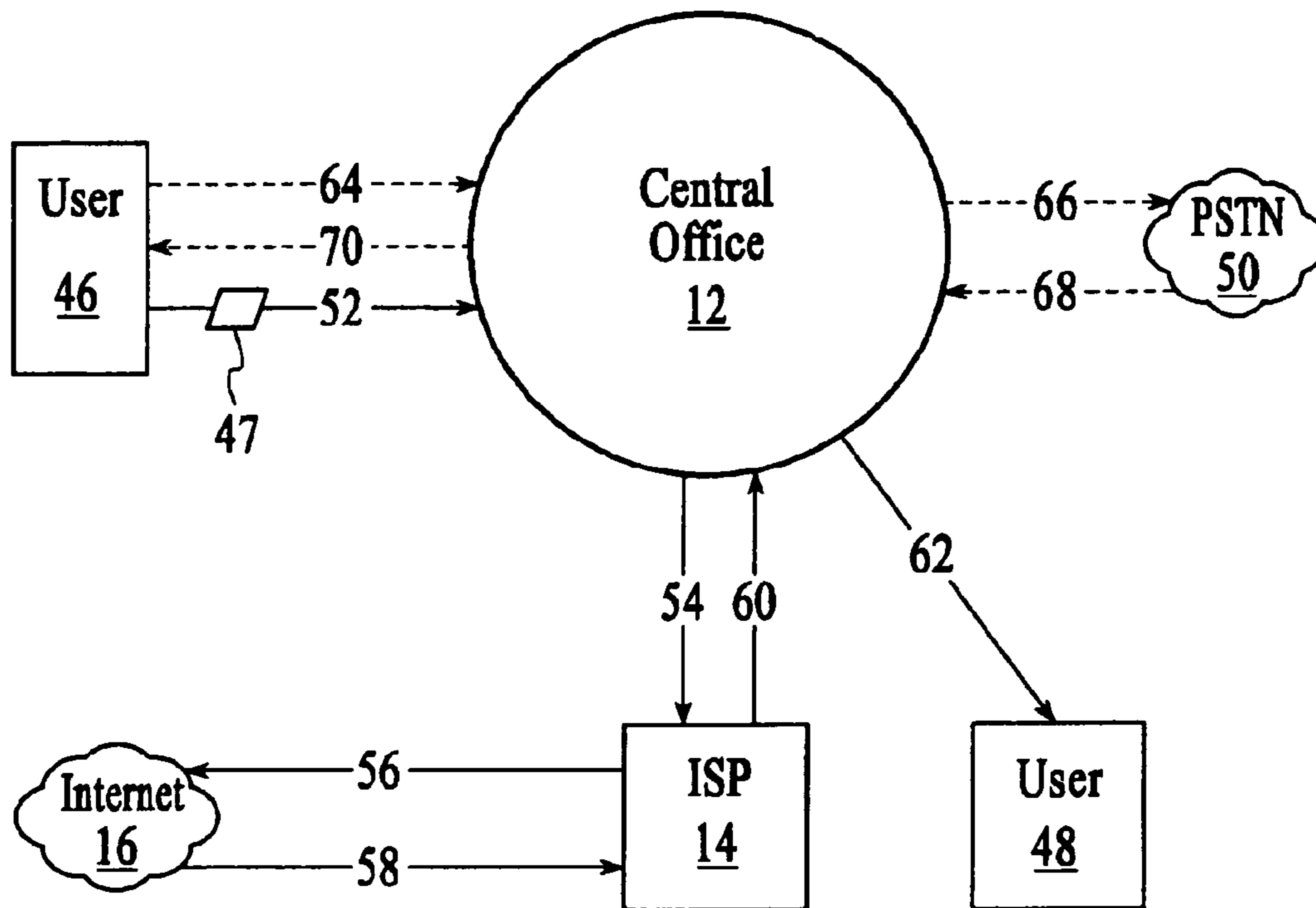

**FIG.1B**  
(PRIOR ART)

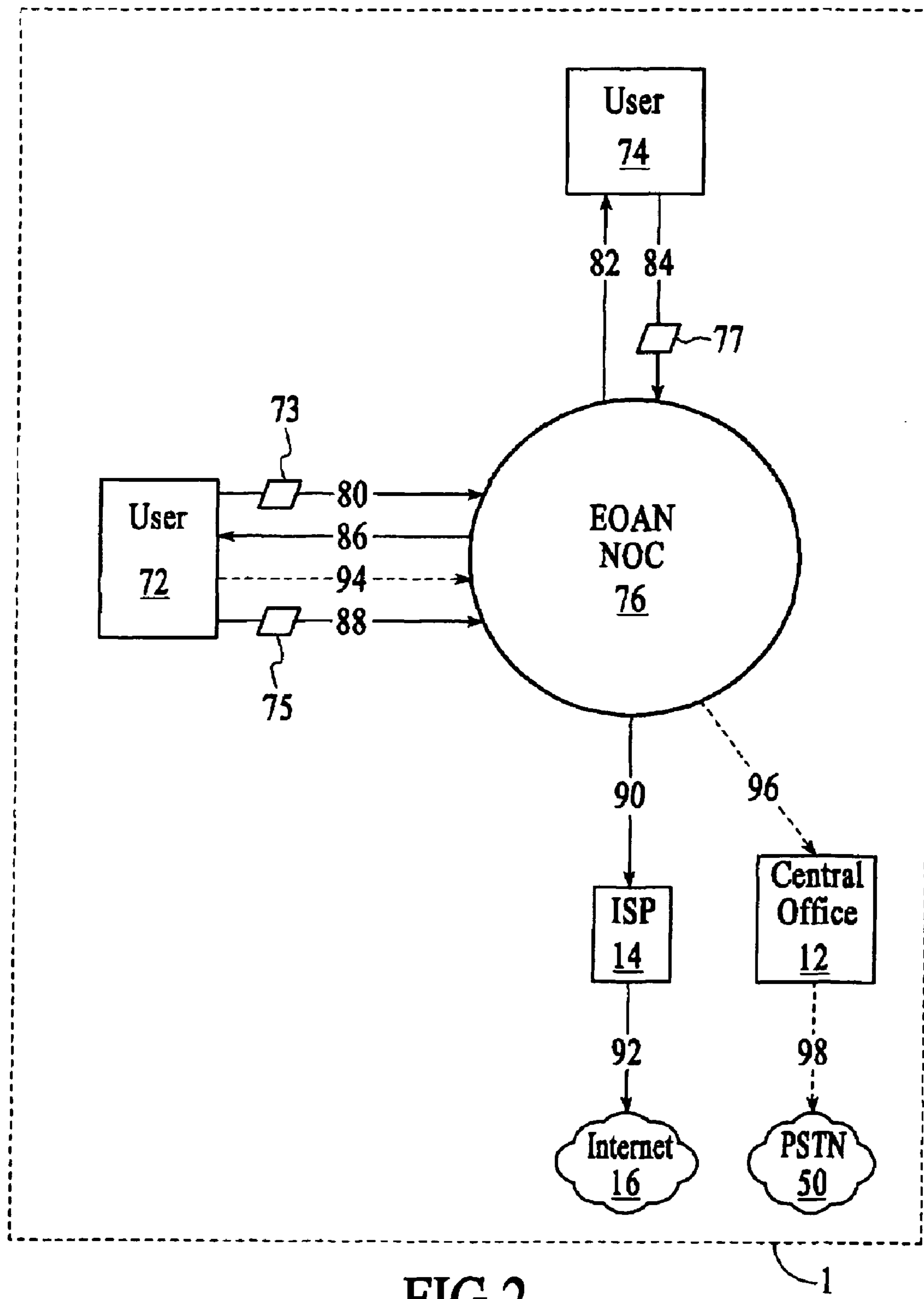

FIG.2



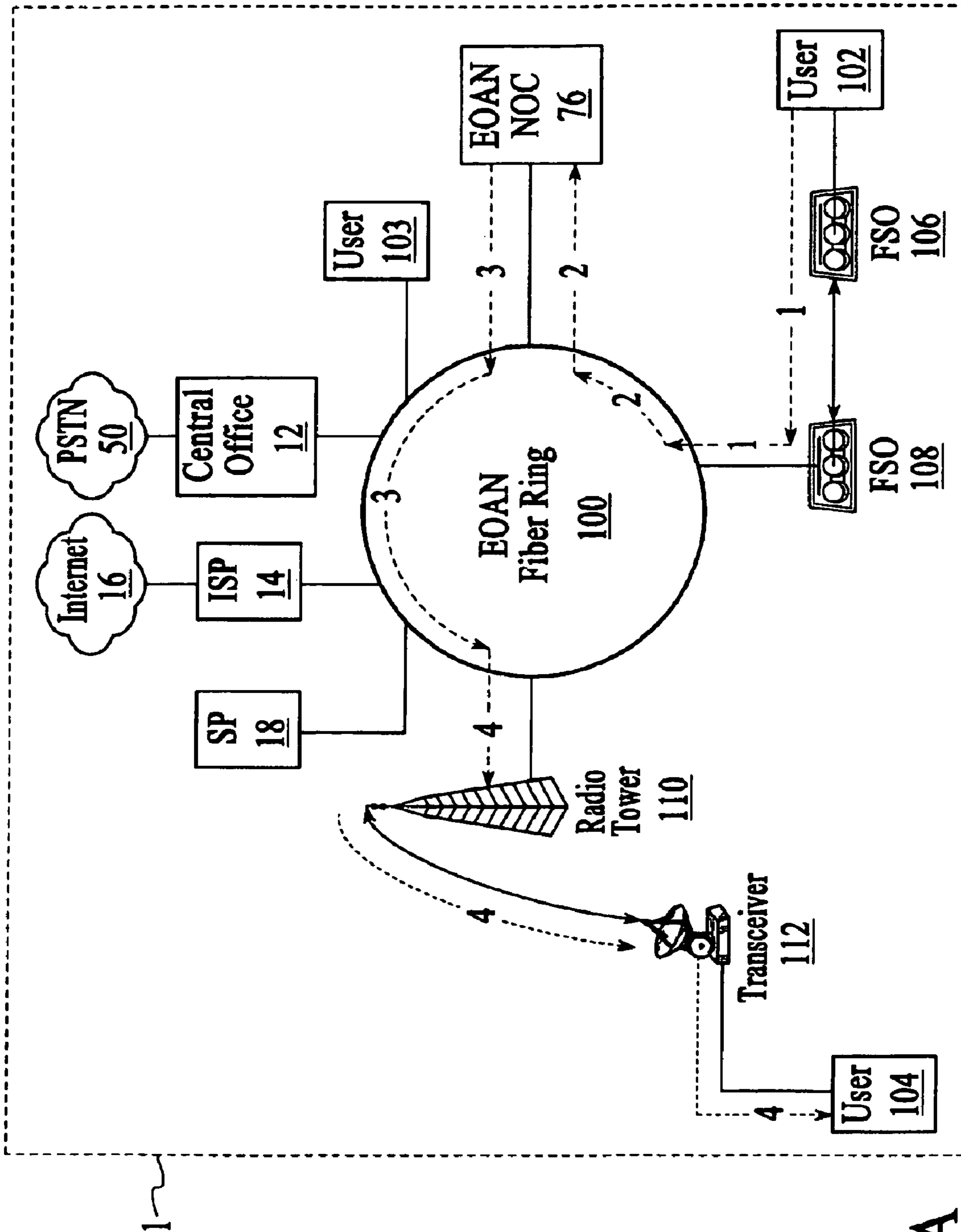

FIG.3A

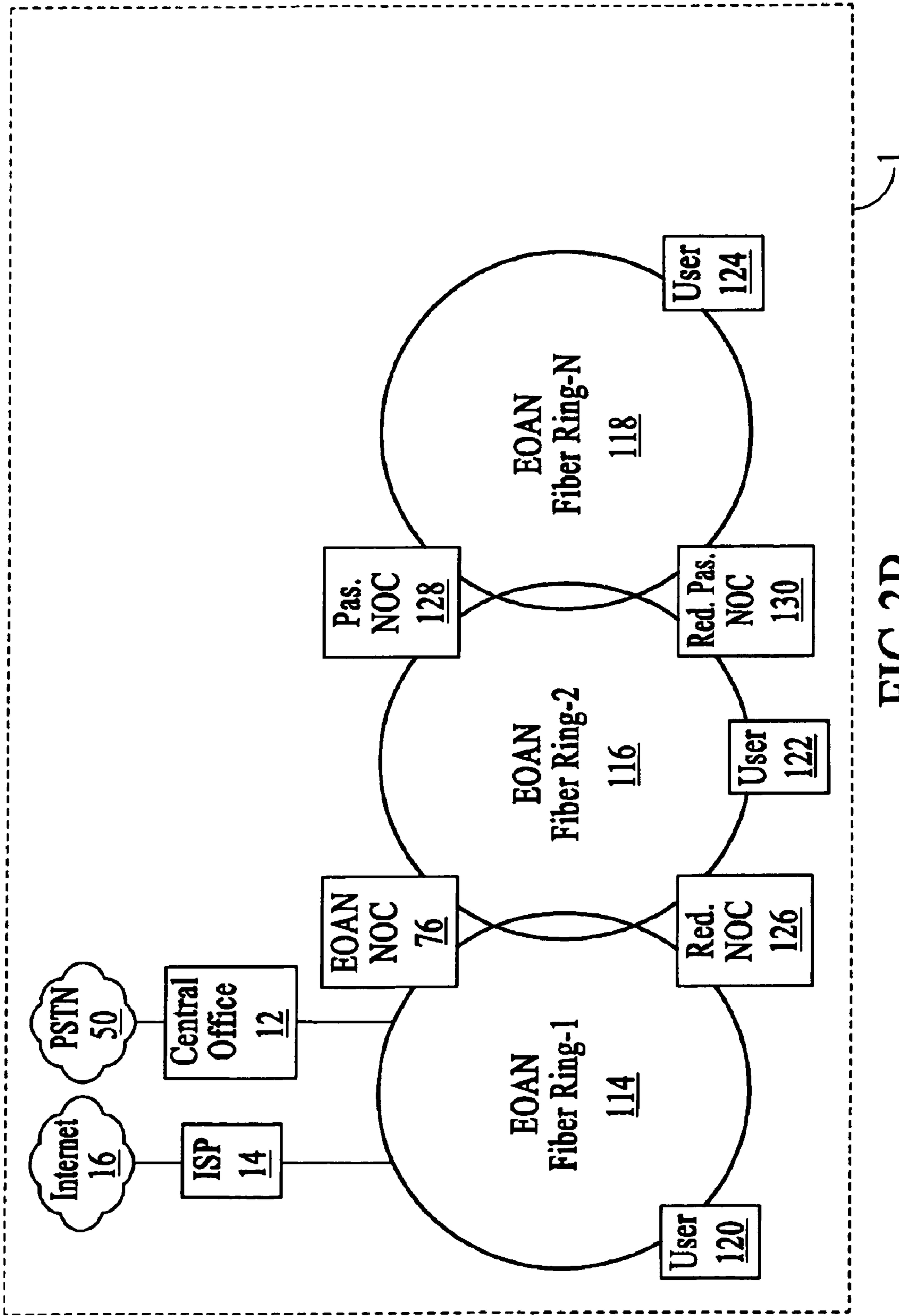

FIG.3B

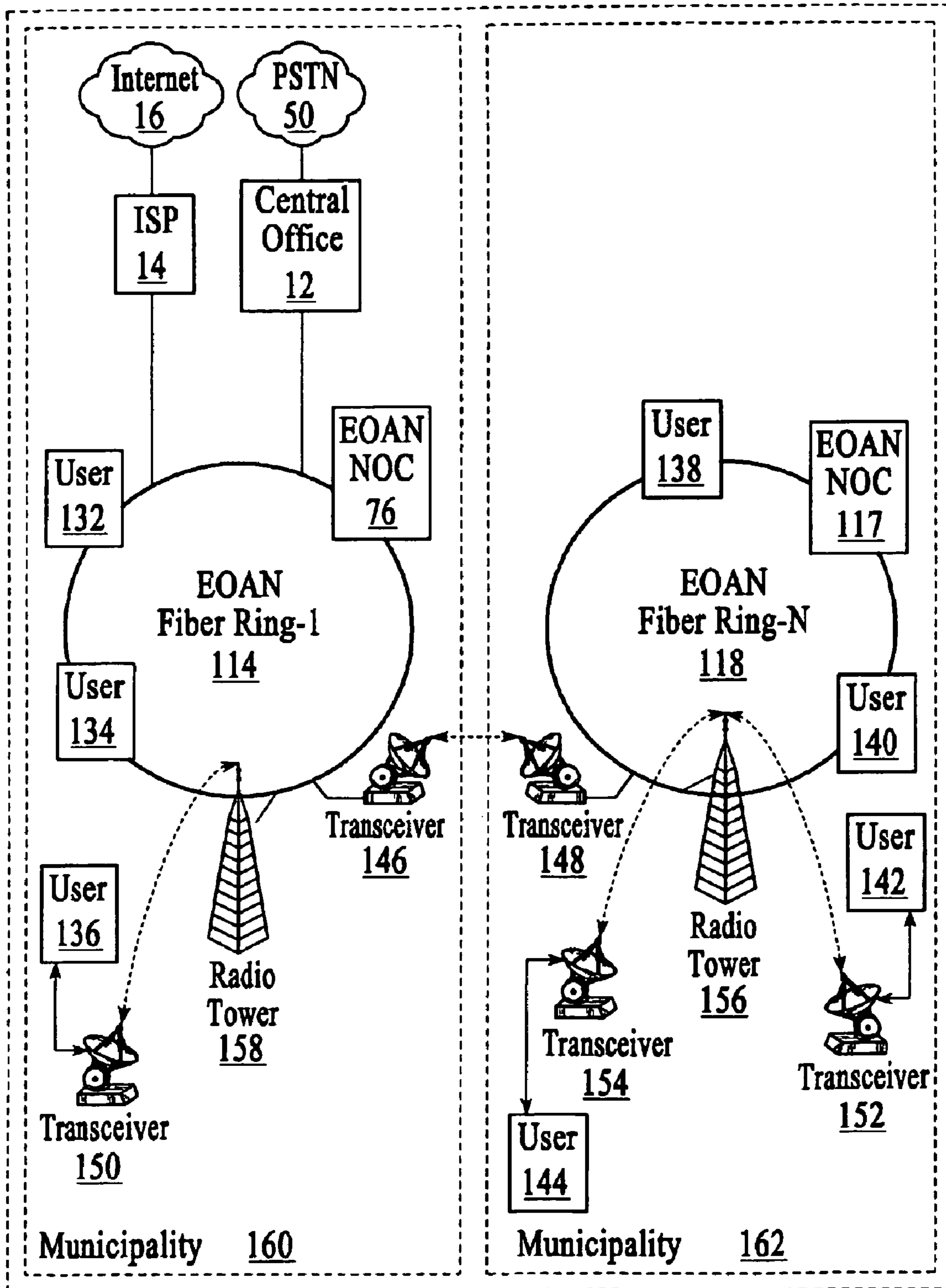

FIG.3C

1



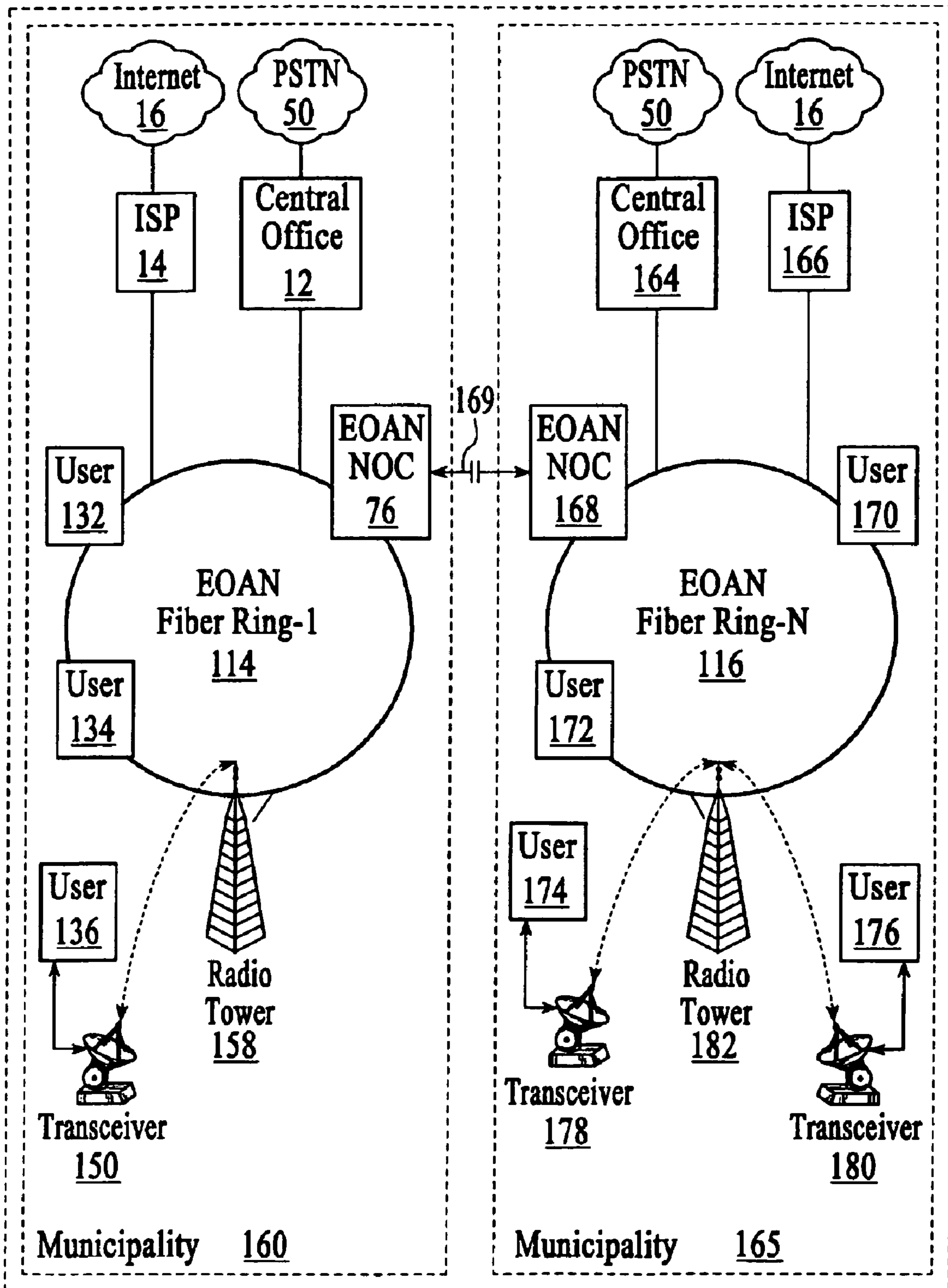

FIG.3D

1

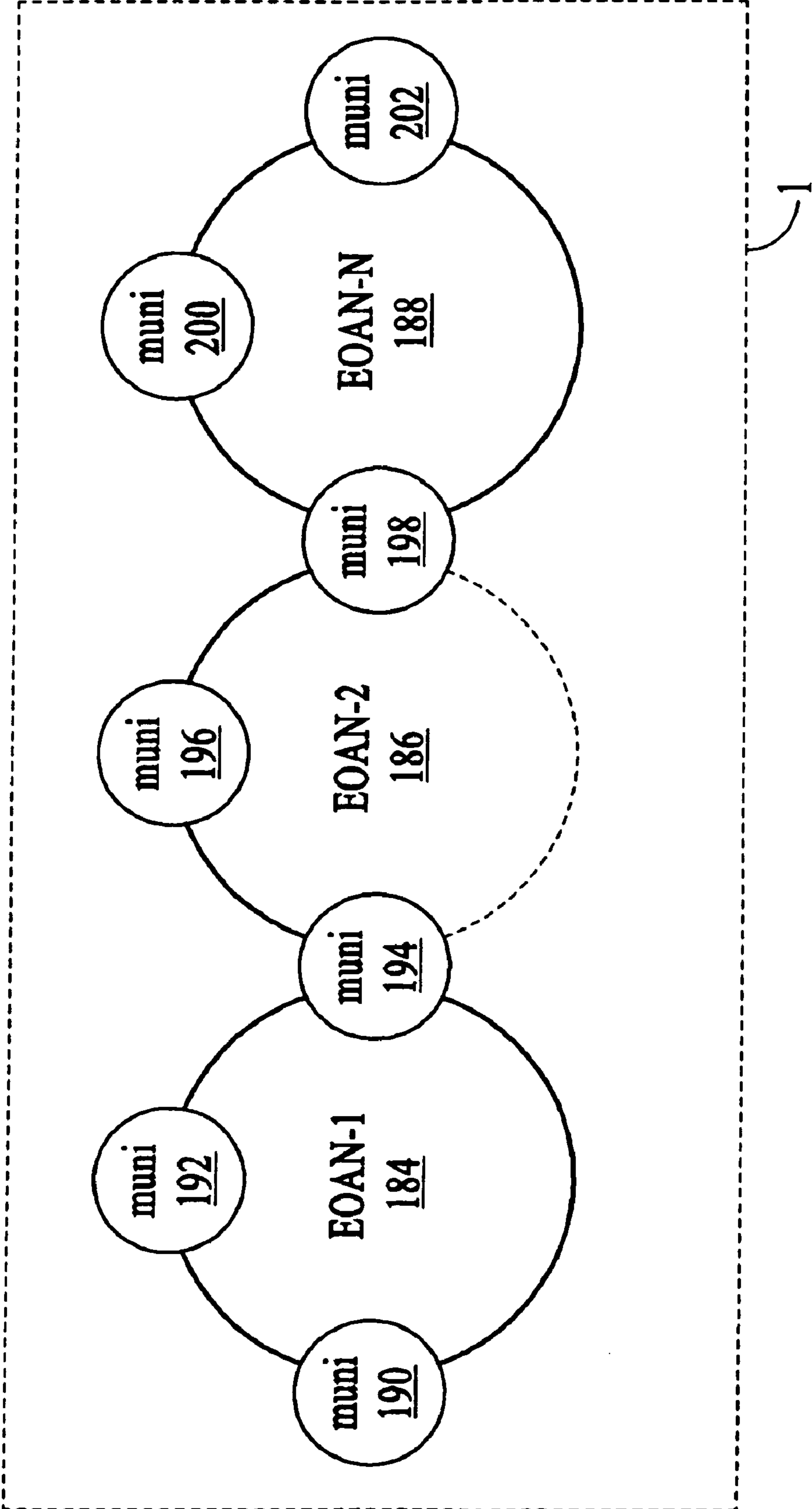

FIG.3E

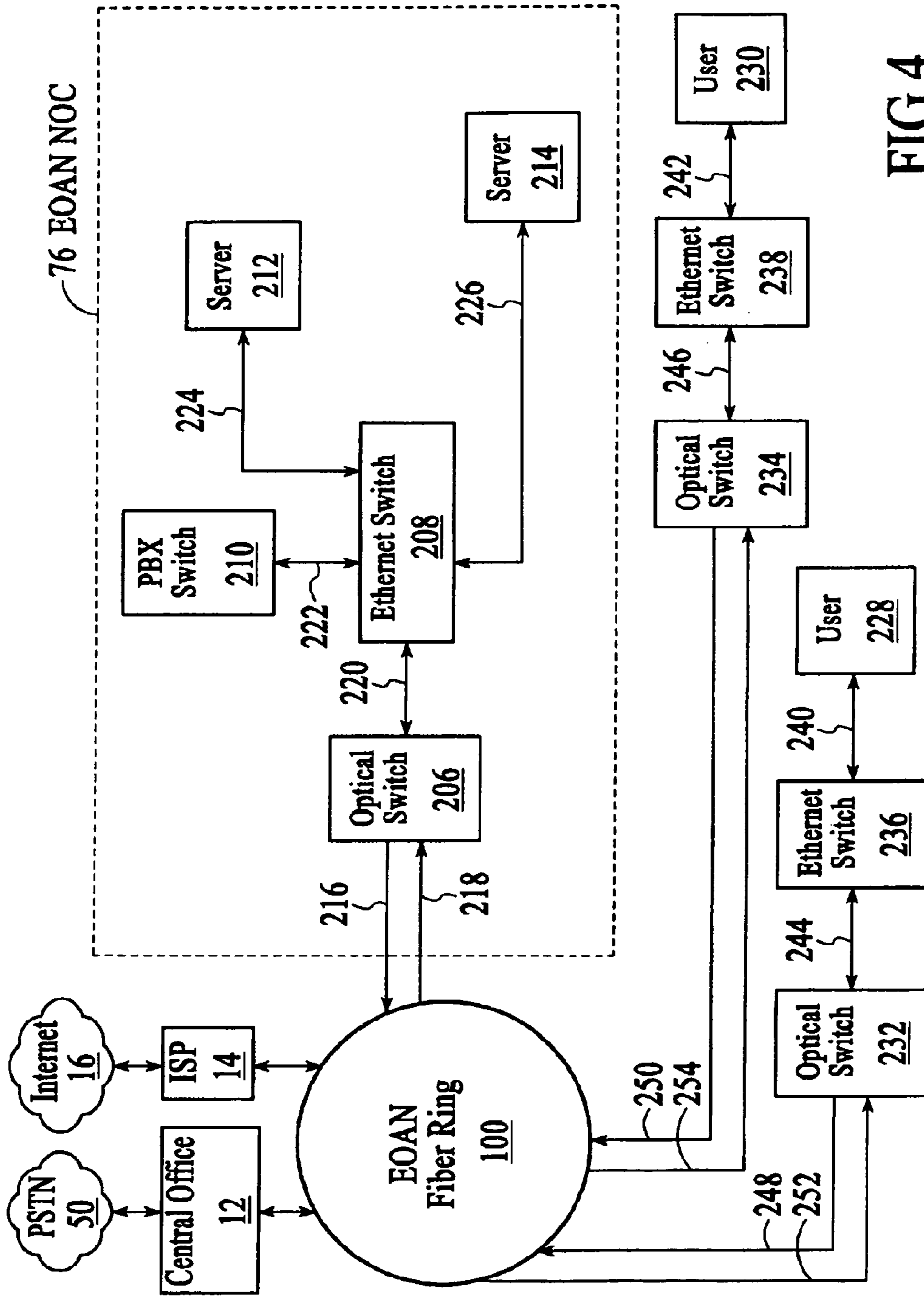

FIG.4

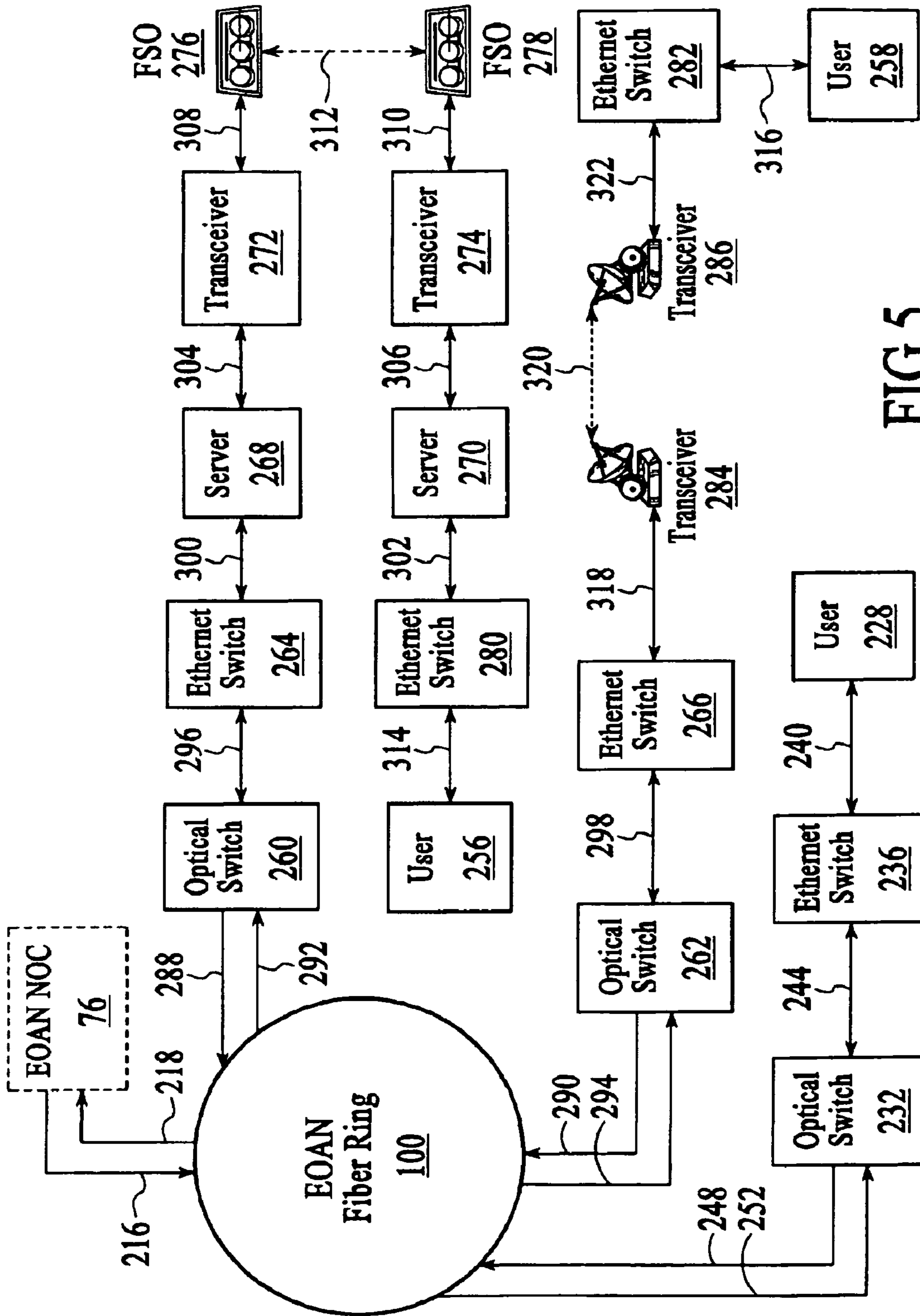

FIG. 5



**METHOD FOR OPERATING AN ETHERNET  
OPTICAL AREA NETWORK (“EOAN”) OVER  
ONE OR MORE METROPOLITAN AREAS**

**Matter enclosed in heavy brackets [ ] appears in the original patent but forms no part of this reissue specification; matter printed in italics indicates the additions made by reissue.**

This application is a continuation of U.S. Application Ser. No. 10/001,524, filed Oct. 24, 2001, now U.S. Pat. No. 7,167,648.

FIELD OF THE INVENTION

The invention generally relates to the fields of voice and data communications, specifically metropolitan area networks, Ethernet networks and fiber optic rings. More particularly, the present invention relates to an Ethernet optical area network system and methods for providing Ethernet protocol end-to-end and uses thereof.

BACKGROUND OF THE INVENTION

Data communications is one of the fastest growing segments of the telecommunications industry. Bandwidth, speed, latency, reliability, security, and Quality of Service (QoS) remain paramount concerns for data communications networks. However, current data communication networks connect to and often include the public telephone system, which was originally designed for analog (voice) communications. The public telephone system places inherent limits on the development of efficient, high-speed, digital data transmissions.

Currently data routing through a central switching office occurs across a local loop, which often consists of Unshielded Twisted Pair (UTP) copper cable. As is understood by one skilled in the art, UTP cable is a low-frequency transmission media and has a limited frequency range of approximately 300 Hz to 3300 Hz. While data rates of 100 Mbps are possible for short distances across UTP cable, 56 Kbps generally is considered the standard rate for analog telephone lines. Thus, the transmission media most often used by the central switching offices of local telephone companies is not conducive to high-speed data transmission.

While Local Area Networks (LANs) within company offices can operate at speeds measured in Gigabits per second (Gbps), data transmissions between offices over Wide Area Networks (WANs) and Metropolitan Area Networks (MANs) are subject to the speed constraints of the so-called “last mile.” The “last mile” refers to the physical copper connection of local access lines between the central switching office of a telephone company and an end-user, lines that typically are controlled by RBOCs (Regional Bell Operating Companies) and other telecommunications companies. These companies have invested billions of dollars in building the “last mile” with UTP cable, but such technology now acts as a bottleneck to the transmission of large data files and streaming media between offices outside the LAN. Currently there are few incentives for the RBOCs and other telecommunications companies to rapidly implement new technology solutions and replace this installed copper base of UTP.

Bandwidth is also a defining element in allowing state-of-the-art applications to fully exploit their capabilities. When data is sent to and from branch offices, bandwidth is critical to

making the files useful. As applications grow more complex, the various types of files (data, graphic, audio, video, etc.) have tended to grow larger and larger. For example, medical networks require high-speed data rates to achieve timely and efficient data communications between separate facilities, such as hospitals, clinics and research institutes, but UTP cable does not transmit well over anything but very short distances. Currently, data from most medical equipment, such as a Magnetic Resonance Imaging (MRI) system, cannot be efficiently transmitted between separate facilities because the data files (which frequently include numerous images) are typically too large. For instance, an MRI system, which may be used to help diagnose tumors in a cancer patient, requires specialized software (such as what is known as “syngo”) for high-resolution imaging and produces image files in a standard format (such as a DICOM file format) that may include hundreds of image files. The problem is the present bandwidth of most medical intranets cannot achieve the necessary speeds for efficient data transmission between facilities outside of a LAN environment.

Remote hosting has also been restricted by the limitations of the public telephone network. Typically, an Internet Service Provider (ISP) or other web hosting company provides a server for back-up service. Connectivity beyond the physical limitations of the 10/100 Base-T Ethernet cables is available through dedicated lines, dial-up access, etc., but connection speeds drop dramatically once outside the Ethernet network. For example, speeds within the LAN using Ethernet vary from 10 Mbps to 10 Gbps, while speeds outside the LAN on UTP cable vary from 56 Kbps to 45 Mbps. The legacy transmission media and its protocols of the public telephone system are the main reasons for the slower data rates.

The present invention attempts to address such limitations of current data communications between WANs and MANs with Ethernet Optical Area Network (EOAN) systems. Such EOAN systems extend the LAN infrastructure of companies and organizations beyond the physical boundaries of the office or campus. The present invention is based on the Ethernet protocol, which is the current standard transmission protocol for LANs. The present invention provides routerless and server-less network access to outside networks at the same speed at which a computer inside an office is connected to a LAN. Such EOAN systems, for example, will allow businesses within the same metropolitan area to create private networks with unparalleled speed and ease of management at a fraction of the present cost.

EOAN systems provide companies and organizations within the same metropolitan area with high-speed data communications via Fast Ethernet, Gigabit Ethernet, and 10 Gigabit Ethernet. In accordance with the present invention, EOAN systems enable companies and organizations to communicate with each other at data rates that are potentially more than 80 times current bandwidth connections. The present invention can attain such high-speed data rates by combining wireless connections, fiber optics, and Ethernet capable switches to create a network that has the ability to deliver Terabits of information over metropolitan area networks and that is cost-effective for small to medium-sized businesses. The interconnectivity of EOAN systems provides data transport for a variety of services, which may include private network security, satellite office interconnectivity, carrier grade Voice over IP (VoIP), ultra high-speed Internet access, real-time remote imaging, high quality video conferencing, real-time distance learning, cooperative data environments, etc.

SUMMARY OF INVENTION

The present invention provides what is referred to herein as Ethernet Optical Area Network (EOAN) system, and meth-



ods for implementing and using such an EOAN system. In accordance with the present invention, an EOAN system is provided that may be used to improve the speed and reliability of data communications networks for small to medium-sized companies in metropolitan area networks. An EOAN system provides end-to-end Ethernet protocol, enabling professionals to have high-speed data communications in real time. As will be appreciated, the present invention may be generally utilized for improving data communications between branch offices, home offices, campuses, and remote sites for a wide variety of industries. The present invention preferably includes a fiber optic ring, Network Operation Center (NOC), NOC architecture components, existing client equipment, and one or more Free Space Optic (FSO) devices, microwave communication technology, and/or data switching platforms to implement high-speed Ethernet-based connections within a specified metropolitan area. The present invention preferably integrates a plurality of FSO, microwave, and/or fiber optic technologies with Ethernet protocol (Fast Ethernet, Gigabit Ethernet, 10 Gigabit, etc.) to provide data connection services that will enable users to connect at rates that may be potentially more than 80 times the current, conventional bandwidth connections.

An object of the present invention is to provide a system and methods for data communications, which integrate FSO, microwave, and fiber optic technologies with Ethernet protocol (Fast Ethernet, Gigabit Ethernet, 10 Gigabit, etc.) in accordance with the present invention.

Another object is to provide a system and methods for delivering end-to-end Ethernet protocol (Fast Ethernet, Gigabit Ethernet, 10 Gigabit, etc.) between a plurality of users in separate locations but on the same optical network in accordance with the present invention.

A further object is to provide a system and methods for high-speed data communications for satellite office interconnectivity in real time in accordance with the present invention.

Still a further object of the present invention to provide a system and methods for high-speed data communications with network-wide Internet access, real-time remote imaging, carrier grade VoIP, high quality video conferencing, and/or real-time distance learning in accordance with the present invention.

Yet another object is to provide a system and methods for high-speed data communications and interconnectivity for a plurality of networks (i.e., legal, medical, insurance, etc.) in accordance with the present invention.

#### BRIEF DESCRIPTION OF THE DRAWINGS

The present invention may be more fully understood by a description of certain preferred embodiments in conjunction with the attached drawings in which:

FIG. 1A is a diagram illustrating a conventional network topology for data communications via a central switching office of a local telephone company;

FIG. 1B is a diagram illustrating an alternate embodiment of a conventional network topology for voice and data communications via a central switching office of a local telephone company;

FIG. 2 is a diagram illustrating a network topology for an Ethernet Optical Area Network (EOAN) system in accordance with one preferred embodiment of the present invention;

FIG. 3A is a diagram illustrating an EOAN network in accordance with a preferred embodiment of the present invention;

FIG. 3B is a diagram illustrating an EOAN network with a plurality of fiber optic rings in accordance with another preferred embodiment of the present invention;

FIG. 3C is a diagram illustrating an EOAN network serving a plurality of municipalities in accordance with another preferred embodiment of the present invention;

FIG. 3D is a diagram illustrating an alternate embodiment of an EOAN network serving a plurality of municipalities in accordance with another preferred embodiment of the present invention;

FIG. 3E is a diagram illustrating an EOAN network serving a plurality of metropolitan areas in accordance with another preferred embodiment of the present invention;

FIG. 4 is a diagram illustrating NOC architecture for an EOAN system in accordance with a preferred embodiment of the present invention; and

FIG. 5 is a diagram illustrating client architecture for an EOAN system in accordance with a preferred embodiment of the present invention.

#### DETAILED DESCRIPTION OF PREFERRED EMBODIMENTS

The present invention will now be described in greater detail with reference to particular preferred and alternative embodiments. Such description is for a more complete understanding of the background, utility and application of the present invention, and is without being bound by any particular theory or the like.

FIG. 1A is a diagram illustrating a conventional network topology for data communications using a central switching office of a local telephone company. In accordance with current conventions, user 10 is coupled to central office 12, which is connected to ISP 14, Internet 16, and service provider 18. Typically user 10 is a single location business without a Dedicated Access Line (DAL) such as a T-1 connection. Central office 12 is a central switching office of a local telephone company. ISP 14 is an Internet Service Provider that provides a variety of utilities and services to users (such as user 10, etc.) and is connected to one or more Network Access Points (NAPs) typically on the digital backbone of the Internet. Service provider 18 preferably is a company that provides data and/or services to a plurality of users (such as user 10, etc.) via the Internet (such as Internet 16). Within such a conventional network, user 10 may access Internet 16 and send data to service provider 18 (and vice versa).

As illustrated in FIG. 1A, in order for user 10 to transmit/receive data to and from Internet 16, user 10 must connect to ISP 14 via central office 12. For example, in accordance with current conventions, user 10 transmits data 11 via UTP cable 20 (e.g., providing a standard telephone connection at up to 56 Kbps, etc.) to central office 12, which routes data 11 via UTP cable 22 (e.g., providing large bandwidth connection via T-1 at 1.54 Mbps, etc.) to ISP 14, which then routes data 11 back via UTP cable 24 to central office 12, which then transmits data 11 via fiber optic cable 26 (e.g., providing carrier class connection via OC-12 at 622 Mbps, etc.) to Internet 16. Thus, as noted in the example, a minimum of four hops across the network generally is required for data 11 of user 10 to reach Internet 16.

Data communications through a central switching office of a local telephone company (such as central office 12) poses several limitations to high-speed data transmission. For example, in accordance with current conventions illustrated in FIG. 1A, central office 12 typically uses UTP cable for data routing across a local loop. As will be understood by one skilled in the art, UTP cable has a frequency range basically



5

limited to approximately 300 Hz to 3300 Hz. In certain circumstances (such as for single location businesses without Dedicated Access Lines or DALs, etc.), digital signals from user 10 must be converted with a modem to analog signals before being transmitted to central office 12. For instance, user 10 modulates (i.e., converts) data 11 and transmits data 11 via UTP cable 20 to central office 12, which routes data 11 via UTP cable 22 to ISP 14, wherein ISP 14 receives data 11, demodulates data and routes it via UTP cable 24 back to central office 12, which then routes data 11 via fiber optic cable 26 to Internet 16.

As further illustrated in FIG. 1A, service provider 18 may transmit data to user 10 and vice versa. In order for service provider 18 to transmit data and provide services to user 10, for example, data of service provider 18 must make eight hops across the network. Accordingly, service provider 18 must transmit data 19 to central office 12, which routes data 19 to ISP 14, which routes data 19 back to central office 12, which then transmits data 19 to Internet 16, which sends data back to central office 12, which routes data 19 to ISP 14, which routes data 19 back to central office 12, which finally routes data 19 to user 10. Accordingly, eight hops are required for service provider 18 to send data 19 to user 10. Moreover, the data must be converted several times during the process. Such data conversions not only slow data transmission, but also may cause jitter in audio communications because of the latency. For example, service provider 18 preferably transmits data 19 via UTP cable 28 (e.g., providing large bandwidth connection via T-1 at 1.54 Mbps) to central office 12, which routes data 19 via UTP cable 30 (e.g., providing T-1 connection at 1.54 Mbps) to ISP 14, wherein ISP 14 receives data 19 through one or more servers that route data 19 via UTP cable 32 (e.g., providing T-1 connection at 1.54 Mbps) to central office 12, which then routes data 19 via fiber optic cable 34 (e.g., providing OC-12 connection at 622 Mbps) to Internet 16. (As will be understood by one skilled in the art, Internet 16 may route data across the NAPs of the digital backbone of the Internet through multiple Metropolitan Area Exchanges (MAEs) back to central office 12.) Accordingly, Internet 16 then routes data 19 via fiber optic cable 36 (e.g., providing OC-12 connection at 622 Mbps) to central office 12, which routes data 19 via UTP cable 38 (e.g., providing T-1 connection at 1.54 Mbps) to ISP 14, which then transmits data 19 via UTP cable 40 to central office 12, which routes data 19 via UTP cable 42 (e.g., providing a standard telephone connection at a rate of up to 56 Kbps) to user 10.

FIG. 1B is a diagram illustrating an alternate embodiment of a conventional network topology for voice and data communications using a central switching office of a local telephone company. Such a conventional network provides separate voice and data communications across the Public Switched Telephone Network (PSTN) and the Internet via a central switching office of a local telephone company. In accordance with current conventions, user 46 connects to central office 12, which is coupled to ISP 14, user 48, and PSTN 50. Preferably users 46-48 are single location businesses without a Dedicated Access Lines (DALs), and central office 12 is a central switching office of a local telephone company. ISP 14 preferably is an Internet Service Provider that provides a variety of utilities and services to a plurality of users (such as users 46-48) and is connected to one or more NAPs on the digital backbone of the Internet. PSTN 50 preferably includes local, long distance, and international telephone companies (such as RBOCs, etc.) and their Local Access and Transport Areas (LATAs). Within such a conven-

6

tional network, user 46 may place a telephone call via central office 12 through PSTN 50 and may transmit data through central office 12 to user 48.

As illustrated in FIG. 1B, in order for user 46 to transmit/receive data to and from another user (such as user 48), user 46 must have access to an ISP (such as ISP 14) via a central switching office of a local telephone company (such as central office 12). For example, in accordance with current conventions, user 46 transmits data 47 via UTP cable 52 (e.g., providing a standard telephone connection at a rate of up to 56 Kbps) to central office 12, which routes data 47 across UTP cable 54 (e.g., providing T-1 connection at 1.54 Mbps, etc.) to a router at ISP 14, which then routes data 47 via fiber optic cable 56 (e.g., providing OC-3 connection at 155 Mbps, etc.) to Internet 16, which routes data 47 back via fiber optic cable 58 (e.g., providing OC-3 connection at 155 Mbps, etc.) to ISP 14, which sends data 47 via UTP cable 60 (e.g., providing T-1 connection at 1.54 Mbps, etc.) to central office 12, which then sends data 47 via UTP cable 62 (e.g., providing a standard telephone connection at a rate of up to 56 Kbps, etc.) to user 48. A minimum of six hops across the network typically is required for data 47 to reach user 48 from user 46.

Moreover, when data (such as data 47) is sent from one or more users (such as user 46) via the central office (such as central office 12) to an ISP (such as ISP 14), for instance, the data is typically modulated into an analog signal before being transmitted to the central office. Likewise, for example, when data (such as data 47) is being sent from ISP 14 to user 48, the data must be modulated by the ISP before being transmitted to the user (such as user 48), who must in turn demodulate (via CSU/DSU) the data upon receipt. Thus, six hops and multiple data conversions typically are required for one user to send data to another user.

As further illustrated in FIG. 1B, a user (such as user 46) can place a local or long distance call separately through a central switching office of a local telephone company (such as central office 12). In spite of recent trends toward voice/data convergence, voice and data communications often remain separated for efficiency of high-speed transmissions across WANs and MANs. For instance, user 46 makes a telephone call and sends a signal via analog line 64 to central office 12, which routes the signal via analog line 66 to PSTN 50, which then makes the connection and sends back a signal via analog line 68 to central office 12, which routes signal via analog line 70 to user 46 to complete the connection.

Although FIGS. 1A and 1B illustrate a single central office for background discussion purposes, it will be appreciated that such conventional network topologies utilize numerous interconnected central offices with similar limitations and operational inefficiencies.

FIG. 2 is a diagram illustrating an exemplary embodiment of a network topology for an Ethernet Optical Area Network (EOAN) system in accordance with the present invention. In a preferred embodiment, EOAN system 1 is a private data network (incorporating voice communications) that provides network connectivity with the geographical range of a MAN, but primarily uses Ethernet protocols for data communications. Accordingly, it should be noted that data preferably includes a plurality of data types (data, graphic, audio, video, etc.) that may be suitable for data communication via Ethernet protocols. Moreover, data communications as used hereinafter may incorporate voice communications and virtually all types of data. In accordance with the present invention, EOAN system 1 utilizes standard, high-speed Ethernet protocols (e.g., Fast Ethernet, Gigabit Ethernet, 10 Gigabit Ethernet, etc.), which allows for internetworking of data transmission devices. As will be understood by one skilled in the



art, these protocols enable very high-speed data communications with real-time streaming media.

In accordance with the present invention, user **72** is preferably connected to EOAN NOC **76**, which is a Network Operations Center (NOC) that provides data switching and management functions. (EOAN NOC **76** will be described in further detail in connection with FIG. **4**.) Users **72-74** preferably are single location businesses, whereas central office **12** is a central switching office of a local telephone company. It should be noted that users refer to clients and their existing technology (which may include, for example, Ethernet switches, hubs, servers, and other devices necessary for the client's LAN/data network). ISP **14** provides a variety of utilities and services to a plurality of users (i.e., user **72**, user **74**, etc.) and is connected to one or more NAPs on the digital backbone of the Internet. PSTN **50** preferably includes local, long distance, and international telephone companies and their LATAs. Data (such as data **73**) may include a plurality of data files (audio, video, graphic, data, etc.) and can be transmitted/received in a plurality of protocols (e.g., Ethernet, ATM, etc., although in preferred embodiments an Ethernet-based protocol is used) via a plurality of transmission media (such as FSO, optical signals, microwaves, infrared light, etc.) and physical pathways (such as UTP, fiber optic cable, etc.). Optical network connections **80-88** and **94** preferably consist of a plurality of types of physical pathways and transmission media (such as FSO, fiber optic cable, microwaves, infrared light, etc.) that may be used to transmit/receive data. Fiber optic cable **90** (e.g., OC-3, OC-12, etc.) is a conventional fiber optic cable. NAP connection **92** provides a connection to a Network Access Point on the digital backbone at broadband speeds (e.g., DS3, OC-3, OC-12, etc.). Network connection **96** preferably includes a wide range of types of transmission media that may be used to transmit/receive data preferably via a suitable telecommunications protocol (including UTP cable, FSO, fiber optic cable, microwaves, infrared light, etc.), and preferably is a fiber optic connection using a telecommunications protocol such as OC-3 to enable a suitable, high speed connection between EOAN NOC **76** and central office **12**. PSTN backbone connection **98** preferably provides a connection to a backbone of the Public Switched Telephone Network (PSTN) at a plurality of speeds.

In accordance with the present invention, user **72** is coupled via an optical network connection to EOAN NOC **76**, which in turn is connected to central office **12**, user **74**, and ISP **14**. Unlike conventional MAN topologies, user **72** can transmit data **73** via Ethernet protocol through EOAN NOC **76** to user **74** with only two hops across the network. In the process, data **73** of user **72** does not have to leave the local EOAN. Moreover, user **72** can access Internet **16** via ISP **14** in three hops or can place a telephone call through PSTN **50** via central office **12** in three hops at very high speeds.

As illustrated in FIG. **2**, unlike conventional MAN and WAN-based networks, a user (e.g., user **72**) preferably transmits data (e.g., data **73**) to one or more users (e.g., user **74**) without having to transmit data through a central switching office of the local telephone company (e.g., central office **12**) or without having to access an ISP (e.g., ISP **14**). In an exemplary embodiment of the present invention, user **72** transmits data **73** via optical network connection **80** to EOAN NOC **76**, which routes data **73** via optical network connection **82** to user **74**. It should be noted that optical network connections **80-82** preferably provide high-speed Ethernet connections (i.e., Fast Ethernet, Gigabit Ethernet, 10 Gigabit Ethernet, etc.) and attach to the LANs or other data networks of users **72** and **74**. In accordance with the present invention, user **72** may transmit data **73** to user **74** with only two hops

across the network of EOAN system **1**. In addition, data **73** does not need to be converted or modulated to be transmitted. Moreover, users may communicate bi-directionally (i.e., exchange data, send e-mail, make telephone calls, etc.) with each other. For example, user **74** may transmit data to user **72**. For example, user **74** may send data **77** via optical network connection **84** to EOAN NOC **76**, which routes data **77** via optical network connection **86** to user **72**. Thus, users may also transmit data to each other with two hops across the network.

As further illustrated in FIG. **2**, a user (e.g., user **72**) may preferably send data via the Internet (e.g., Internet **16**) without having to transmit the data through a central switching office (e.g., central office **6**). In an exemplary embodiment of the present invention, user **72** transmits data **75** via optical network connection **88** to EOAN NOC **76**, which routes data **75** via fiber optic cable **90** to ISP **14**, which in turn sends data **75** via NAP connection **92** to Internet **16**. The present invention requires only three hops across the network of EOAN system **1** for data **75** from user **72** to reach Internet **16**. Moreover, in accordance with the present invention, for a user to access the Internet, data (such as data **75**) does not need to be modulated prior to transmission because it is being transmitted via an Ethernet protocol. In accordance with the present invention, users may communicate bi-directionally with each other.

In accordance with the present invention as illustrated in FIG. **2**, a user (e.g., user **72**) may also place a phone call via a NOC (e.g., EOAN NOC **76**) through a central switching office (e.g., central office **12**). In an exemplary embodiment of the present invention, user **72** may transmit voice data via optical network connection **94** to EOAN NOC **76**, which may convert the voice data to telecommunication protocols via an IP-enabled PBX and transmit the voice signal via (preferably) optical network connection **96** to central office **12** via a suitable telecommunications protocol, which then routes the voice signal via optical network connection **98** to PSTN **50**. In an alternate embodiment of the present invention, user **72** may transmit voice data using a suitable telecommunication protocol directly to central office **12** via EOAN NOC **76**.

FIG. **3A** is a diagram illustrating an exemplary embodiment of EOAN system **1**. In accordance with the present invention, EOAN fiber ring **100** is a component of an Ethernet-based network and consists of a fiber optic ring, comprised of groupings of optical fibers (e.g., **144** optical fibers, etc.). Preferably EOAN fiber ring **100** connects a plurality of users, facilities, and/or devices, and is a self-healing fiber optic ring utilizing one or more pairs of fibers, wherein data is sent in both directions simultaneously around the ring to provide redundancy in case a connection is severed. For example, EOAN fiber ring **100** may be a continuous fiber optic ring physically analogous to a Synchronous Optical Network (SONET) ring.

In accordance with the present invention, central office **12**, EOAN NOC **76**, and a plurality of data transmission equipment, such as radio towers (e.g., radio tower **110**) and Free Space Optic (FSO) devices (e.g., FSO **108**), are coupled to EOAN fiber ring **100**. While not expressly shown or central to the present invention, connections to EOAN fiber ring **100** preferably are made by what are typically known as fiber optic laterals to suitable optical multiplexers or switches. In a typical arrangement, a physical break in the transmit/receiver fiber pair may be made with lateral fibers optically coupled to and extending from the broken fibers to the optical multiplexer/switch, which selectively (such as by wavelength) may receive or transmit or forward optical data along the fiber ring (the use of such a multiplexer or switch, particularly optical



switches, is discussed later in connection with FIGS. 4 and 5). What is important is that suitable fiber optic connections be made to EOAN fiber ring 100 in order for the EOAN-type of network as described herein to be implemented and operated as described herein.

Preferably EOAN NOC 76, which is a NOC that provides data switching and management functions, is linked to ISP 14, which provides utilities and services to a plurality of users and is coupled to one or more NAPs on a digital backbone of the Internet. (It should be noted that in accordance with the present invention, an additional redundant NOC may be coupled to EOAN fiber ring 100 in order to provide redundancy; the additional redundant NOC preferably provides equivalent functionality in the event that EOAN NOC 76 fails or is otherwise unable to provide the routing, management and control functions as described herein.) ISP 14, in turn, is coupled to Internet 16. Central office 12 is a central switching office of a local telephone company. Preferably FSO 106-108 are either Point-to-Point (P2P) or Point-to-Multipoint (P2M) laser devices that support Ethernet signaling natively and provide a continuous optical connection. Radio tower 110 and transceiver 112 transmit/receive microwave frequencies to and from users, transceivers, and/or other radio towers via P2P or P2M delivery method. Service provider 18 preferably is a company that provides data and/or services to a plurality of users (such as users 102-104, etc.) and is connected to EOAN fiber ring 100 preferably via a fiber optic lateral. In addition, user 102 preferably is a single location business located within the greater metropolitan area and connected to EOAN fiber ring 100 via FSO 106; user 104 is preferably a remote user located within a certain distance (wherein the certain distance falls within the current limits of microwave technology, i.e., within 35 miles, etc.) from the greater metropolitan area and is connected to EOAN fiber ring 100 via microwave transceiver (such as transceiver 112). User 103 preferably is a single location business connected to EOAN fiber ring 100 via a fiber optic lateral.

In an alternate preferred embodiment of the present invention, ISP 14 may be coupled directly to EOAN NOC 76, wherein, for example, the equipment in EOAN NOC 76 and ISP 14 may be co-located in the same facility.

It is important to note that while the protocol used to transmit/receive data throughout EOAN system 1 is primarily an Ethernet protocol, other protocols may be used in particular circumstances in accordance with the present invention. For instance, telecommunications protocols may be used to transmit voice data to central office 12 when required by a user. For example, such voice data may be transmitted to/from central office 12 in accordance with a suitable telecommunications protocol (such as an OC-3 protocol) via the same fiber optic ring. In one preferred embodiment, EOAN NOC 76 provides voice data to/from central office 12 using a separate wavelength of the WDM wavelengths utilized to transmit data over EOAN fiber ring 100. With such an embodiment, one wavelength may in effect be dedicated for communications with central office 12 utilizing a suitable telecommunications protocol, while all other data transmissions within the EOAN preferably use an Ethernet-based protocol. It also should be noted that the physical transmission media may change depending on particular circumstances.

In accordance with the present invention, in order for one or more users in a metropolitan area to send data to one or more users in a remote location, the user in a metropolitan area (such as user 102) may transmit data via EOAN system 1 to one or more users in a remote location (such as user 104) via a plurality of data transmission technologies using an

Ethernet protocol. In an exemplary embodiment of the present invention, user 102 is coupled to FSO 106, which, as will be understood by one skilled in the art, may be implemented so as to not require protocol conversion and may be implemented within a certain radius (wherein the certain radius falls within the current limits of FSO transmission technology, i.e., within 2-kilometer radius, etc.). User 102 preferably transmits data via an Ethernet protocol via an optical network connection (such as fiber optic cable, etc.) or LAN cable to FSO 106, which sends optical signals to FSO 108, which is coupled to EOAN fiber ring 100 (see e.g., FIG. 5). FSO 108 preferably receives the data and transmits them across EOAN fiber ring 100 to EOAN NOC 76, which routes the optical signals to radio tower 110, where the optical signals are converted to microwave signals and sent to transceiver 112, which converts the microwave signals to electrical signals and sends the data preferably via standard LAN cable to user 104. In accordance with the present invention, users may communicate bi-directionally with each other, and preferably using an Ethernet-based protocol as described herein.

As will be understood by one skilled in the art, microwave transmission devices can support Ethernet protocols natively, can exceed 2.4 Gbps, and can have an extensive transmission range of up to 35 miles radius. Thus, unlike conventional MAN technologies, user 102 preferably can transmit data to user 104 via EOAN system 1 in approximately four hops (as illustrated by the dashed lines) while effectively maintaining a local Ethernet connection.

As further illustrated in FIG. 3A, users (such as user 102) may also access the Internet (such as Internet 16) via EOAN system 1. In an exemplary embodiment, user 102 transmits data via Ethernet protocol via optical fiber or LAN cable to FSO 106, which converts electrical signals to optical signals and sends the data to FSO 108, which is coupled to EOAN fiber ring 100. FSO 108 transmits the optical signals via EOAN fiber ring 100 to EOAN NOC 76, which routes the data to ISP 14 and onto Internet 16. Such data transmissions do not require the loss of the Ethernet connection.

In accordance with the present invention, one or more users (such as user 102, etc.) may also connect telephone calls via EOAN fiber ring 100 with EOAN system 1. In an exemplary embodiment, user 102 transmits voice data using an Ethernet protocol via optical fiber or LAN cable to FSO 106, which converts electrical signals to optical signals and sends the voice data to FSO 108, which is coupled to EOAN fiber ring 100. FSO 108 receives the optical signals and transmits them across EOAN fiber ring 100 to EOAN NOC 76, which converts the Ethernet protocols into telecommunication protocols preferably with an IP-enabled PBX and routes the voice data preferably via EOAN fiber ring 100 (such as using a suitable telecommunications protocol and preferably using a dedicated wavelength or channel, as previously described) to central office 12, which is coupled to PSTN 50 and connects the telephone call (as will be appreciated by those of skill in the art, return signals/data transmissions complete the telephone call). Alternatively, voice data may be coupled between EOAN NOC 76 and central office 12 using a separate connection (e.g., UTP cable, fiber optic cable, etc.), and not utilizing EOAN fiber ring 100 as the transport medium for such connection.

In accordance with an alternate embodiment of the present invention, user 102 may transmit voice data using telecommunication protocols via optical fiber or LAN cable to FSO 106, which converts electrical signals to optical signals and transmits the voice data to FSO 108, which is connected to EOAN fiber ring 100. FSO 108 transmits the data across EOAN fiber ring 100 to EOAN NOC 76, which routes the



voice data using telecommunication protocols to central office **12** (such as previously described), which is coupled to PSTN **50** and connects the telephone call.

FIG. **3B** is a diagram illustrating an exemplary embodiment of a plurality of fiber rings connected via EOAN system **1**. In accordance with the present invention, EOAN fiber ring-**1 114**, EOAN fiber ring-**2 116** and EOAN fiber ring-**N 118** are fiber optic rings that connect a plurality of users, facilities, and/or devices and have properties consistent with EOAN fiber ring **100**, such as described in conjunction with FIG. **3A**. In accordance with the present invention, central office **12**, ISP **14**, EOAN NOC **76**, redundant NOC **126**, and a plurality of users, such as user **120**, are coupled to EOAN fiber ring-**1 114**; EOAN NOC **76**, redundant NOC **126**, passive NOC **128**, passive redundant NOC **130**, and a plurality of users, such as user **122**, are coupled to EOAN fiber ring-**2 116**; and passive NOC **128**, passive redundant NOC **130**, and a plurality of users, such as users **124**, are coupled to EOAN fiber ring-**N 118**. Preferably EOAN NOC **76** provides data switching and management functions and is coupled to both EOAN fiber ring-**1 114** and EOAN fiber ring-**2 116**. ISP **14**, which is connected to EOAN fiber ring-**1 114** and Internet **16**, provides utilities and services to a plurality of users and is coupled to one or more NAPs on a digital backbone of the Internet. Central office **12** is a central switching office of a local telephone company coupled to EOAN fiber ring-**1 114**. Redundant NOC **126** preferably is a NOC that provides equivalent data switching and management capabilities as EOAN NOC **76** and serves as a redundant NOC for EOAN NOC **76**. Preferably user **120** is connected to EOAN fiber ring-**1 114** via optical network connection (e.g., fiber optic cable, etc.), while user **122** is connected to EOAN fiber ring-**2 116** via optical network connection (e.g., fiber optic cable, fiber optic lateral and optical multiplexer or switch, etc.). It is important to note that EOAN fiber ring-**1 114** and EOAN fiber ring-**2 116** are coupled together via both EOAN NOC **76** and redundant NOC **126**. Thus, in accordance with the present invention, one or more fiber rings may be coupled together using one or more NOCs.

As further illustrated in FIG. **3B**, in an alternate preferred embodiment of the present invention, a passive NOC (such as passive NOC **128**), which serves as a two-way repeater, may be implemented at a node connecting one or more fiber rings (such as EOAN fiber ring-**2 116** and EOAN fiber ring-**N 118**). Redundant passive NOC **130** may also be coupled to EOAN fiber ring-**2 116** and EOAN fiber ring-**N 118** in order to provide redundancy; redundant passive NOC **130** preferably provides equivalent functionality to passive NOC **128**.

It is important to note that a plurality of fiber rings may be connected to one NOC, but additional NOCs (such as redundant NOCs, redundant passive NOCs, etc.) are recommended for redundancy purposes. For example, EOAN fiber ring- **1 114** and EOAN fiber ring-**2 116** may be connected by EOAN NOC **76** without redundant or passive NOCs. In accordance with the present invention, EOAN system **1** may connect a plurality of fiber rings via a plurality of NOCs, but only one NOC is required as long as reliable high-speed data communication can be maintained consistent with the data switching and other capabilities of the one NOC, etc.

In accordance with the present invention, one or more users (such as users **120-122**) in a metropolitan area may send data to each other via separate but connected fiber rings (such as EOAN fiber ring-**1 114** and EOAN fiber ring-**N 116**, etc.). For example, user **120** may transmit data via Ethernet protocol via EOAN fiber ring-**1 114** to EOAN NOC **76**, which routes the data via EOAN fiber ring-**2 116** to user **122**. In accordance

with the present invention, users may communicate bi-directionally with each other across separate connected fiber rings.

FIG. **3C** is a diagram illustrating an exemplary embodiment of a plurality of municipalities connected via EOAN system **1**. In accordance with the present invention, one or more municipalities, such as Dayton, Ohio and Springfield, Ohio, may be connected via EOAN system **1**. Preferably, EOAN fiber ring-**1 114** and EOAN fiber ring-**N 118** are fiber optic rings that connect a plurality of users, facilities, and/or devices and have properties consistent with EOAN fiber ring **100**, such as described in conjunction with FIG. **3A**. In this exemplary embodiment, EOAN fiber ring-**1 114** is preferably connected to EOAN fiber ring-**N 118** via microwave transceivers (such as transceivers **146-148**). Preferably EOAN NOC **76** is a NOC that provides data switching and management functions and is coupled to EOAN fiber ring-**1 114**. ISP **14** connected to EOAN fiber ring-**1 114** provides utilities and services to a plurality of users and is coupled to Internet **16**. Central office **12** is a central switching office of a local telephone company coupled to EOAN fiber ring-**1 114**. EOAN NOC **117** preferably provides equivalent data switching and management capabilities as EOAN NOC **76**. Radio towers **156-158** preferably transmit/receive microwave frequencies to and from users, microwave transceivers, and/or other radio towers. Preferably, a plurality of users (such as users **132-136**) are connected to EOAN fiber ring-**1 114** and a plurality of users (such as users **138-144**) are connected to EOAN fiber ring-**N 118**. For example, user **132** and user **138** may be single location businesses, while user **134** and user **140** may be main offices for multi-office businesses. Preferably, user **136** is located within the greater metropolitan area of municipality **160** and connected to EOAN fiber ring-**1 114** via microwave technology in this example. Likewise, users **142-144** are located within the greater metropolitan area of municipality **162** and connected to EOAN fiber ring-**118 N** via microwave technology in this example. User **136** may be a remote office affiliated with user **140**, while users **142-144** may be remote offices affiliated with user **134**. It should be noted that remote offices may include branch offices, home offices, etc., that may be located in a single-tenant building or a multi-tenant building. Transceivers **146-154** and radio towers **156-158** transmit/receive microwave frequencies to and from users, microwave transceivers, and/or other radio towers via a P2P or P2M delivery method. (In an alternate preferred embodiment, transceiver **148** may be directly coupled to radio tower **156**.)

As illustrated in FIG. **3C**, in accordance with the present invention, users may share data communications with other users in the same municipality. For instance, a user (such as user **132**) may send data to one or more users (such as users **134-136**). User **132**, which is connected to EOAN NOC **76** via an optical network connection (e.g., fiber optic cable, fiber optic lateral and optical multiplexer or switch, etc.), transmits data via an Ethernet protocol across EOAN fiber ring-**1 114** to EOAN NOC **76**, which routes the data to user **134**. In addition, user **132** may send the same data to user **136**; in this example user **132** sends data via an Ethernet protocol across EOAN fiber ring-**1 114** to EOAN NOC **76**, which routes the data to radio tower **158**, where the optical signals are converted to microwave signals and transmitted to transceiver **150**. Transceiver **150** converts the microwave signals to electrical signals and sends the data to user **136**. Accordingly, users may communicate bi-directionally with each other on the same fiber ring.

In accordance with the present invention, users in one municipality (such as municipality **160**) may also share the same data communications with users in another municipal-



ity (such as municipality **162**). Microwave technology may be used to connect municipalities on separate fiber rings located within a certain distance of each other (wherein the certain distance falls within the current limits of microwave technology, for example, within 35 miles, etc.). For instance, a user in one municipality (such as user **132**) may send data to one or more users in a different municipality (such as users **138-140**). User **132**, which preferably is connected to EOAN NOC **76** via an optical network connection (e.g., fiber optic cable, fiber optic lateral and optical multiplexer or switch, etc.), transmits data via an Ethernet protocol across EOAN fiber ring-**1 114** to EOAN NOC **76**, which routes the data via an Ethernet protocol to transceiver **146**. Transceiver **146** converts optical signals to microwave signals and transmits the microwave signals to transceiver **148**. Upon receipt of the microwave signals, transceiver **148** converts the microwave signals back to optical signals and sends the data to EOAN NOC **117**, which routes the data via an Ethernet protocol to users **138-140**. In accordance with the present invention, users may communicate bi-directionally with each other across the separate fiber optic rings.

As further illustrated in FIG. 3C, one or more users in one municipality, such as user **134**, may send data to one or more users in remote office locations in another municipality, such as user **142-144**. For example, user **134** transmits data via an Ethernet protocol across EOAN fiber ring-**1 114** to EOAN NOC **76**, which switches the data to transceiver **146**, which converts optical signals to microwave signals and transmits them to transceiver **148**. Transceiver **148** receives the microwave signals and converts them back to optical signals and sends the data via an Ethernet protocol to EOAN NOC **117**, which routes the data to radio tower **156**, where optical signals are converted to microwave signals and transmitted to transceivers **152-154**. Transceivers **152-154** convert the microwave signals to electrical signals and send the data via an Ethernet protocol to users **142-144**, respectively. Accordingly, users may communicate bi-directionally with each other across separate fiber rings.

It is important to note that transceivers **146-154** and radio towers **156-158** may use a P2P or P2M delivery methods. For example, radio tower **158** may transmit microwave signals to a single transceiver (e.g., transceiver **150**), a single radio tower (e.g., radio tower **156**), or a plurality of transceivers and/or radio towers (e.g., transceivers **146-154**, radio tower **156**, etc.).

In accordance with the present invention, one or more users in one municipality, such as user **140**, etc., may also place a telephone call through central office **12** in another municipality. For example, user **140** transmits voice data (using Voice Over IP, for example) via optical signals across EOAN fiber ring-**N 118** to EOAN NOC **117**. EOAN NOC **117** routes the voice data to transceiver **148**, which converts optical signals to microwave signals and transmits them to transceiver **146**. Transceiver **146** preferably receives the microwave signals and converts them back to optical signals and sends the voice data to EOAN NOC **76**, which converts the data into telecommunication protocols with a PBX switch and routes the voice data via optical signals across EOAN fiber ring-**1 114** to central office **12**, which connects the telephone call via PSTN **50**.

In alternate preferred embodiments of the present invention, one or more users in one municipality, such as user **140**, etc., may also place a telephone call via standard telecommunication protocols through central office **12** in another municipality. For instance, user **134** transmits voice data via standard telecommunication protocols via optical signals across EOAN fiber ring-**N 118** to EOAN NOC **117**, which

routes the voice data to transceiver **148**, which converts optical signals to microwave signals and transmits them to transceiver **146**. Transceiver **146** receives the microwave signals and converts them back to optical signals and sends the voice data to EOAN NOC **76**, which routes the voice data via telecommunications protocols via optical signals across EOAN fiber ring-**1 114** to central office **12**, which connects the telephone call via PSTN **50**. In such embodiments, as described earlier herein, dedicated channels or wavelengths may be dedicated to such telecommunication protocol communications with central office **12**, which may serve to facilitate the convenient implementation of voice-telephony services over the EOAN.

It should be noted that in an alternate embodiment of the present invention, an additional radio tower may be provided to extend the range of microwave transmissions. For instance, users **142-144** may be connected to EOAN fiber ring-**N 118** via an additional radio tower, which may act as a repeater and transmit microwave signals between radio tower **156** and transceivers **152-154**. Thus, user **138** may send data to user **142** by transmitting data via an Ethernet protocol via EOAN fiber ring-**N 118** to EOAN NOC **117**, which routes optical signals to radio tower **156**, where the optical signals are converted to microwave signals and transmitted to an additional radio tower, which may process and/or amplify the microwave signals and send them to transceivers **152-154**. Transceivers **152-154** then convert the microwave signals to electrical signals and sends the data via an Ethernet protocol to users **142-144**, respectively. In accordance with the present invention, the range of microwave transmissions between users may be extended via one or more radio towers functioning as repeaters.

FIG. 3D is a diagram illustrating another exemplary embodiment of one or more municipalities connected via EOAN system **1**. In accordance with the present invention, one or more municipalities, such as Dayton, Ohio and Cincinnati, Ohio, may be connected via EOAN system **1**. Preferably EOAN fiber ring-**1 114** and EOAN fiber ring-**N 116** are fiber optic rings that connect a plurality of users, facilities, and/or devices and have properties consistent with EOAN fiber ring **100**, such as described in conjunction with FIG. 3A. It should be noted that EOAN fiber ring-**1 114** and EOAN fiber ring-**N 116** are separate fiber optic rings and have separate connections to central offices (such as central office **12** and central office **164**). Central office **12** is coupled to PSTN **50** and ISP **14** and central office **164** is connected to PSTN **50** and ISP **166**. ISP **14** and ISP **166** are connected to Internet **16**. EOAN fiber ring-**1 114** is preferably connected to EOAN fiber ring-**N 116** via a long haul fiber connection (such as long haul fiber **169**, which, for example, may consist of leased and/or purchased fiber optic cable and which may have repeaters in order to implement the long haul fiber connection).

As illustrated in FIG. 3D, long haul fiber **169** preferably provides the only network connection between EOAN fiber ring-**1 114** and EOAN fiber ring-**N 116**. Users may communicate bi-directionally with each other across the separate fiber rings. Preferably EOAN NOC **76** and EOAN NOC **168** are NOCs that provide data switching and management functions such as previously described, and are coupled to EOAN fiber ring-**1 114** and EOAN fiber ring-**N 116**, respectively. ISPs **14** and **166** provide utilities and services to a plurality of users and are coupled to one or more NAPs. ISP **14** is connected to EOAN fiber ring-**1 114** and Internet **16**. ISP **166** is connected to EOAN fiber ring-**N 116** and Internet **16**. Central offices **12** and **164** are central switching offices of local telephone companies coupled to EOAN fiber ring-**1 114** and



EOAN fiber ring-N **116**, respectively. Radio towers **158** and **182** preferably transmit microwaves frequencies to and from users, microwave transceivers, and/or other radio towers. Preferably a plurality of users (such as users **132-136**, etc.) are connected to EOAN fiber ring-1 **114** and a plurality of users (such as users **170-178**, etc.) are connected to EOAN fiber ring-N **116**.

In accordance with the present invention, one or more users in one municipality, such as users **132-136**, etc., may also share the same data communications with one or more users in another municipality, such as users **170-176**, etc., via EOAN system **1**. A long haul optical network connection, such as long haul fiber **169**, may be used to connect municipalities on separate fiber rings located within a certain distance of each other (wherein the certain distance exceeds the current limits of microwave technology, for example, about 60 miles or greater, etc.). For instance, user **132** in municipality **160** may send data to users **170-172** in municipality **165**. Accordingly, user **132** transmits data via an Ethernet protocol across EOAN fiber ring-1 **114** to EOAN NOC **76**, which routes the data via optical signals via long haul fiber **117** to EOAN NOC **168**. EOAN NOC **168** transmits the data via optical signals to users **170-172**. In accordance with the present invention, users may communicate bi-directionally with each other across separate fiber optic rings via a long haul fiber connection using an Ethernet protocol.

FIG. **3E** is a diagram illustrating another exemplary embodiment of a plurality of metropolitan areas connected via EOAN system **1**. In accordance with the present invention, a plurality of municipalities, such as New York, N.Y. and Philadelphia, Pa. and Washington, D.C., etc., may be connected via a plurality of EOAN networks (a municipality providing a plurality of users, facilities, and/or devices to be connected to the fiber optic ring, such as previously described). For instance, municipalities (such as municipalities **190-202**, etc.) are connected via large fiber rings to EOAN networks (such as EOAN-1 **184**, EOAN-2 **186**, EOAN-N **188**, etc.). EOAN networks are components of EOAN system **1**, such as previously described in connection with FIG. **3A-3D**. Preferably EOAN networks connect a plurality of municipalities (such as described in FIGS. **3C** and **3D**), so a plurality of users may share data communication across multiple municipalities and regions. In such embodiments, municipalities **190-194** are connected to EOAN-1 **184**, municipalities **194-198** are connected to EOAN-2 **186**, and municipalities **198-202** are connected to EOAN-N **188**, wherein municipality **194** and municipality **198** are coupled to a plurality of EOAN networks (e.g., EOAN-1 **184**, EOAN-2 **186**, EOAN-N **188**, etc.) and thus serve as nodes to more than one network. In accordance with the present invention, municipalities on fiber rings may be connected to each other via a plurality of types of transmission media (such as FSO, optical signals, microwave signals, infrared light, etc.) and physical pathways (such as UTP, fiber optic cable, long haul fiber, OC-3, OC-12, etc.).

As illustrated in FIG. **3E**, a plurality of municipalities may be connected together as part of EOAN system **1**. In accordance with the present invention, a plurality of municipalities (such as municipalities **190-194**) on one EOAN network (such as EOAN-1 **184**) may be connected to a plurality of municipalities (such as municipalities **194-198**) on another separate EOAN network (such as EOAN-2 **186**). Preferably municipalities on separate EOAN networks may share data communications with each other as long as one or more municipalities serve as nodes to more than one EOAN network in EOAN system **1**. For example, municipality **194** serves as a node for both EOAN-1 **184** and EOAN-2 **186**, and

municipality **198** serves as a node for both EOAN-2 **186** and EOAN-N **188**. Thus, a plurality of users in municipality **190** may communicate bi-directionally with a plurality of users in municipality **202**. Accordingly, one or more users in municipality **190** send data via EOAN-1 **184** to EOAN NOC in municipality **194**, which routes data via EOAN-2 **186** to EOAN NOC in municipality **196**, which in turn routes data via EOAN-2 **186** to EOAN NOC in municipality **198**, which sends data via EOAN-N **188** to EOAN NOC in municipality **202**, which routes data to one or more users in municipality **202**. In accordance with the present invention, such data communications preferably occur within EOAN system **1** using an Ethernet protocol.

As further illustrated in FIG. **3E**, municipalities may remain connected to each other via EOAN system **1** when a single network connection is severed. For instance, a connection (such as optical network connection **204**) on EOAN-2 **186** may be cut, potentially severing communications between two municipalities (such as municipality **194** and municipality **202**). In accordance with the present invention, EOAN system **1** implements a continuous loop network, wherein each node on the network is connected to at least two other nodes in the network. Moreover, EOAN system **1** is connected via a plurality of self-healing fiber optic rings, wherein data are sent in both directions simultaneously across the fiber rings. Thus, if any one connection in an EOAN system **1** is severed, it will not disrupt data communications between nodes on the network. For example, municipality **194** connecting EOAN-1 **184** and EOAN-2 **186** may still communicate with municipality **298** and other municipalities on EOAN-N **188**, such as municipalities **200-202**, when optical network connection **204** is severed. As will be understood based on the description herein, this concept of self-healing fiber rings is applicable generally to the fiber rings disclosed herein.

FIG. **4** is a diagram illustrating an exemplary embodiment of the architecture for a Network Operations Center (NOC) for EOAN system **1**. In accordance with the present invention, EOAN NOC **76** provides Ethernet switching and network management functions, which will be described in further detail below. The network architecture for EOAN NOC **76** preferably includes one or more optical switches or multiplexers (such as optical switch **206**), one or more Ethernet switches (such as Ethernet switch **208**), one or more PBX switches (such as PBX switch **210**), and one or more servers (such as servers **212-214**). Optical switch **206** preferably is a Wave Division Multiplexing (WDM) or Dense Wave Division Multiplexing (DWDM) optical switch (such as Ciena Multiwave Metro, Ciena MultiWave MetroDirector K2, LuxN WavSystem 3234, etc.), which can support a plurality of protocols (Ethernet, SONET, ATM, etc.) and interface rates (OC-3, OC-12, OC-48, OC-192, etc.) on each optical fiber. Optical switch **206**, which will be described in greater detail below, provides a means of expanding the capabilities of fiber optic transmissions by multiplexing wavelengths of light into multiple channels. It should be noted that optical switches, as used herein, primarily are used as bridging multiplexers to bolster bandwidth and performance of EOAN system **1** by providing WDM or DWDM capabilities. Accordingly, the management capabilities of the optical switches, which are typically provided by optical switch management applications (such as LuxN OSLM, Ciena OnCenter, etc.), in preferred embodiments are generally limited to functions, such as monitoring data traffic, etc. Ethernet switch **208** preferably is an intelligent Ethernet switch (such as Extreme Networks BlackDiamond 6808, Extreme Networks BlackDiamond 6816, etc.), which is a Layer 2 switch that is Layer 3 aware,



and is designed with carrier-class fault tolerance for data networks requiring scalability from 100 Mbps to 10 Gbps. PBX switch **210** preferably is a VoIP-enabled PBX switch (such as Nortel Meridian, Lucent DFINITY, Inter-Tel Axxess, etc.) designed for routing voice data from users to PSTN **50** via central office **12**. It should be noted that the network management application (e.g., Extreme Networks ExtremeWare, HP OpenView, etc.) provided in EOAN NOC **76** can view an optical switch management application (such as LuxN OSLM, Ciena OnCenter, etc.). In accordance with the present invention, the optical switches preferably are managed via the optical switch management application (such as LuxN OSLM, Ciena OnCenter, etc.), which may be managed on a network basis via the network management application provided in EOAN NOC **76** (thus, the various optical switches are centrally managed via EOAN NOC in accordance with the present invention). Server **212** preferably is a network management server (such as HP NetServer, etc.) that monitors network activity and runs a network management application (such as Extreme Networks ExtremeWare, HP OpenView, etc.) for purposes of providing such central EOAN management. Server **214** preferably is a database server running a database language (such as SQL, etc.) that houses the database for MAN hosting over EOAN system **1**. In accordance with the present invention, servers **212-214** may be combined into a single server providing the same functionality as server **212** and server **214** or may be separated into more than two servers providing the same functionality as server **212** and server **214**.

In accordance with the present invention, servers **212-214** preferably are coupled to Ethernet switch **208** via LAN cable **224** and LAN cable **226**, respectively. Ethernet switch **208** preferably is connected to optical switch **206** via LAN cable **220** and to PBX switch **210** via LAN cable **222**. LAN cables **220-226** preferably are standard LAN cables (e.g., CAT5 cable for Ethernet, etc.). Optical switch **206** preferably is connected to EOAN fiber ring **100** via one or more pairs of optical fibers (i.e., comprising a transmitting fiber and a receiving fiber, such as fibers **216-218**, etc.) from a fiber grouping (this may be a fiber optical lateral, as previously described). Preferably optical fibers (e.g., fibers **216-218** and **248-254**, etc.) are Single Mode (SM) fibers suitable for WDM and DWDM use, such as, for example, fibers in the 1310 nm band or 1550 nm band. Preferably fiber **216** is a transmitting fiber, which transmits data via EOAN fiber ring **100**, and fiber **218** is a receiving fiber, which receives data via EOAN fiber ring **100**. Fiber ring **100** connects a plurality of users, facilities, and/or devices and has the same properties such as described above in conjunction with FIG. 3A. In accordance with the present invention, servers **212-214**, PBX switch **210**, Ethernet switch **208** and optical switch **206** may communicate bi-directionally with each other.

As will be understood by one skilled in the art, fiber optic cable uses light pulses to carry data. Preferably, optical switches can multiplex light waves into a plurality of channels (e.g., 40 channels), wherein each channel has a different frequency/wavelength and transmits data within specified GHz intervals. With such WDM or DWDM optical switches, each channel can be split into multiple managed groups, which can carry data aggregating at rates of up to 10 Gbps. Thus, in accordance with the present invention, for example, EOAN NOC **76** can support 960 separate connections per each fiber pair at data rates between 100 Mbps to 2.4 Gbps when implementing a DWDM optical switch, such as LuxN WavSystem 3234, Ciena Multiwave MetroDirector K2, etc.

As illustrated in FIG. 4, EOAN NOC **76** is coupled to EOAN fiber ring **100**, which in turn is coupled to central office

**12** and ISP **14**. Preferably ISP **14** provides utilities and services to a plurality of users, and is coupled to Internet **16** and one or more NAPs on a digital backbone of the Internet. Optical switch **206** in EOAN NOC **76** is connected via fibers **216-218** to EOAN fiber ring **100**, which may transmit data at rates in excess of 1.6 Terabits per second per pair of fiber. Preferably central office **12** and a plurality of users (e.g., user **228-230**) are coupled to EOAN fiber ring **100** such as previously described: Central office **12** is a central switching office of a local telephone company and is connected to PSTN **50**.

In accordance with the present invention, EOAN system **1** provides network management, QoS standards, and network security through EOAN NOC **76**. Network management is maintained via server **212** and Ethernet switch **208**. As noted above, server **212** (such as HP NetServer, etc.) monitors network activity via a network management application (such as Extreme Networks ExtremeWare, HP OpenView, etc.), which preferably uses a Simple Network Management Protocol (SNMP) type protocol and provides customer data and service management, and other network capabilities (e.g., switch management, status monitoring, port statistics, network audit logs, event databases, software integration, network security, network modeling, etc.). Server **212** manages Ethernet switch **208**, which is an intelligent switch that may be managed directly via a terminal at server **212** or remotely via a plurality of remote access methods, such as Telnet, SSH2, SNMP, browser-based, device management software (e.g., Extreme Networks ExtremeWare Vista), etc. Thus, from EOAN NOC **76** it is possible to direct data traffic to specific nodes, control potential collisions, and provide maintenance to all parts of EOAN system **1**, including the plurality of optical switches provided in EOAN system **1**. It should be noted that Ethernet switches at customer sites, such as Ethernet switches **236-238**, etc., are also intelligent switches that may be managed directly via a terminal or remotely via a plurality of remote access methods, such as Telnet, SSH2, SNMP, browser-based, device management software (e.g., Extreme Networks ExtremeWare Vista), etc.

Because the Ethernet switches (such as Ethernet switches **208** and **236-238**, etc.) are intelligent switches with policy-based QoS, they can reserve and/or limit bandwidth for specified categories of data (e.g., voice, video, etc.) and/or specified categories of applications (e.g., video applications, database applications, etc.). The Ethernet switches perform these functions by applying priority parameters of the management software application (e.g., Extreme Networks ExtremeWare, etc.). The priority parameters determine how an Ethernet switch (such as Ethernet switch **208**, etc.) allocates bandwidth and data traffic for each hardware queue on each physical port. For example, data may be assigned a priority status for Ethernet switch **208**, so that one type of data (such as voice data, etc.) may be given precedence over another type of data (such as e-mail, etc.) placed in a hardware queue on a physical port. When a plurality of hardware queues on the same physical port are contending for transmission, Ethernet switch **208** accordingly prioritizes bandwidth use and data traffic according to the priority parameters.

It has been found to be advantageous to the establishment and maintenance of QoS for EOAN system **1** to use a consistent brand or type of equipment and network management applications (e.g., Extreme Networks BlackDiamond 6816, Alpine 3804, ExtremeWare, etc.) for managing all Ethernet switches throughout EOAN system **1**. The use of such common-management equipment and application potentially reduces the incompatibilities between different protocols, interfaces, and system requirements by securing consistently



terminated end points. While this is recommended, it is not required for the proper function of EOAN system 1.

In accordance with the present invention, EOAN NOC 76 also monitors EOAN fiber ring 100 and each node in EOAN system 1 for network breaks and faults. Thus, if a break in the fiber ring occurs, then EOAN NOC 76 is not only aware of the break, but can also maintain network connectivity throughout EOAN system 1 until the break is repaired because data is transmitted across the fiber ring simultaneously in both directions. For example, if EOAN NOC 76 is sending data to users 228-230 in EOAN system 1 and a break in EOAN fiber ring 100 occurs, data may continue to be sent to and from users 228-230 because if a break occurs on one side of EOAN fiber ring 100, then the data may reach users 228-230 via the other side of EOAN fiber ring 100. Moreover, EOAN NOC 76 can continue to manage optical switches and Ethernet switches throughout EOAN system 1 as long as data traffic is not entirely cut off from any of the nodes.

It is important to note that in accordance with the present invention EOAN system 1 is a private network. Therefore, network security is maintained because EOAN system 1 does not provide direct access to public networks. Accordingly, all data and data transmissions (including data transmissions being sent to PSTN 50, Internet 16, etc.) are managed by (and pass through) EOAN NOC 76. Thus, data may be transmitted bi-directionally between users 228-230 in a secure environment without modems or routers. Since EOAN system 1 does not provide direct access to public networks and uses a plurality of transmission media, it is exceptionally difficult to break network security. For example, it is difficult to intercept a wireless transmission path (such as FSO transmissions, microwave transmissions, etc.) of EOAN system 1 because such methods require knowing the exact frequency and encryption codes of the transmission (both of which are proprietary). It is also difficult, for example, to tap fiber optic cables of EOAN system 1 without being detected because once the physical pathway is severed the transmission of optical signals is corrupted.

Furthermore, in accordance with the present invention, EOAN system 1 may provide Virtual LAN (VLAN) and Virtual MAN (VMAN) environments for users by tagging all data from all user locations, such as an office, lab, etc., with a unique frame tag. Preferably VLANs are managed with network management protocols via a network management server (e.g., server 212, etc.) of EOAN NOC 76. Moreover, by connecting several VLANs, EOAN system 1 may also provide a VMAN environment, wherein several VLANs may share the same but separate unified network.

As further illustrated in FIG. 4 in accordance with the present invention, users 228-230 are also coupled to EOAN fiber ring 100. Users 228-230 are preferably businesses and may include users, servers, switches, telephones, and/or other devices necessary for voice and data communications in a LAN. User 228 is coupled via LAN cable 240 to Ethernet switch 236, which is coupled via LAN cable 244 to optical switch 232, which is connected via fibers 248 and 252. User 230 is coupled via LAN cable 242 to Ethernet switch 238, which is coupled via LAN cable 246 to optical switch 234, which is connected via fibers 250 and 254 (e.g., a lateral fiber arrangement, such as previously described). Preferably Ethernet switches 236-238 are Ethernet switches (such as Extreme Networks Summit 4, etc.) that provide Ethernet connectivity at a plurality of high-speed rates (such as Fast Ethernet, Gigabit Ethernet, 10 Gigabit Ethernet, etc.). Preferably optical switches 232-234 are either WDM or DWDM optical switches (such as Ciena MultiWave Metro One, etc.) designed for customer premise and short-haul fiber ring

applications. Preferably LAN cables 240-246 are standard LAN cables (e.g., CAT5 cable for Ethernet, etc.). Preferably fibers 248-250 and 216 are transmitting fibers, which transmit data via EOAN fiber ring 100. Likewise, fibers 252-254 and 218 are preferably receiving fibers, which receive data via EOAN fiber ring 100.

As further illustrated in FIG. 4, in preferred embodiments a particular user (such as user 228, etc.) may transmit data to one or more users (such as user 230, etc.) via one or more dedicated channels via EOAN system 1 (where, for example, such one or more dedicated channels are assigned to the particular user). For example, user 228 may transmit data via EOAN fiber ring 100 and EOAN NOC 76 to user 230. In accordance with the present invention, user 228 sends data via LAN cable 240 to Ethernet switch 236, which routes data via LAN cable 244 to optical switch 232, which converts electrical signals to optical signals, multiplexes the optical signals, and sends the data to fiber optic ring 100 via a dedicated channel on transmitting fiber 248. Fiber optic ring 100 routes the data via a dedicated channel on receiving fiber 218 to optical switch 206 in EOAN NOC 76. Optical switch 206 de-multiplexes the optical signals, converts the optical signals back to electrical signals, and sends the data via LAN cable 220 to Ethernet switch 208, which in turn routes data via LAN cable 220 back to optical switch 206, which converts electrical signals to optical signals, multiplexes the optical signals, and sends the data via a dedicated channel on transmitting fiber 216 via fiber optic ring 100. Fiber optic ring 100 routes the data via a dedicated channel on receiving fiber 254 to optical switch 234, which de-multiplexes the optical signals, converts the optical signals to electrical signals and transmits the data via LAN cable 246 to Ethernet switch 238, which routes data via LAN cable 242 to user 230. In accordance with the present invention, users may communicate bi-directionally with each other via dedicated channels. Thus, particular users may be assigned one or more particular channels, wherein other users may not be assigned a particular channel (the data for such other users may be segregated such as by VLAN/VMAN-type frame tags and the like).

As further illustrated in FIG. 4, Ethernet switches may be managed from EOAN NOC 76. Preferably a system administrator at EOAN NOC 76 can monitor the status and functions of each Ethernet switch with the network management application (e.g., Extreme Networks ExtremeWare, HP OpenView, etc.) provided in EOAN NOC 76 by viewing logs, running diagnostics, etc. Ethernet switches at the client site (e.g., Ethernet switches 236-238) may be implemented, for example, to send switch information at pre-determined intervals (e.g., every 10 seconds, 20 seconds, etc.) to server 212 in EOAN NOC 76, which maintains data logs on switch and network performance for each node in EOAN system 1. For instance, Ethernet switch 236 routes data (such as switch information, etc.) via LAN cable 244 to optical switch 232, which converts electrical signals to optical signals, multiplexes the optical signals, and sends the data to fiber optic ring 100 via, for example, a dedicated channel on transmitting fiber 248. Fiber optic ring 100 routes the data via a dedicated channel on receiving fiber 218 to optical switch 206, which de-multiplexes the optical signals, converts optical signals back to electrical signals, and sends the data via LAN cable 220 to Ethernet switch 208, which routes data via LAN cable 224 to server 212. Accordingly, server 212 processes the data by running a suitable network management application (e.g., Extreme Networks ExtremeWare, HP OpenView, etc.), which provides users (such as system administrators, etc.) with the capability to monitor switch performance by viewing logs, running diagnostics, etc.



In another example in accordance with the present invention, Ethernet switch **208** in EOAN NOC **76** can manage network traffic and request data directly from Ethernet switch **232**. Server **212** may send requests for data via LAN cable **224** to Ethernet switch **208**, which routes data via LAN cable **220** to optical switch **206**, which converts electrical signals to optical signals, multiplexes the optical signals, and sends the data via, for example, a dedicated channel on transmitting fiber **216** via fiber optic ring **100**. Fiber optic ring **100** routes the data via a dedicated channel on receiving fiber **252** to optical switch **232**, which de-multiplexes the optical signals, converts optical signals to electrical signals and transmits the data via LAN cable **244** to Ethernet switch **236**, which aggregates data and routes data back to server **212** in accordance with the present invention.

As noted above, EOAN NOC **76** may also manage nodes in EOAN system **1** remotely. Accordingly, Ethernet switch **208** can request data from Ethernet switch **238** remotely. For example, a system administrator may use a network management browser-type application (e.g., ExtremeWare Vista, etc.) to monitor the performance of specific switches in EOAN system **1**. The system administrator contacts server **212** remotely via a plurality of remote access methods, such as Telnet, SSH2, SNMP, browser-based, device management software (e.g., Extreme Networks ExtremeWare Vista), etc. and sends a request for data via LAN cable **224** to Ethernet switch **208**, which routes data via LAN cable **220** to optical switch **206**, which converts electrical signals to optical signals, multiplexes the optical signals, and sends the data via, for example, a dedicated channel on transmitting fiber **216** via fiber optic ring **100**. Fiber optic ring **100** routes the data via a dedicated channel on receiving fiber **254** to optical switch **234**, which de-multiplexes the optical signals, converts optical signals to electrical signals and transmits the data via LAN cable **246** to Ethernet switch **238**, which calls data and routes data back to server **212** in accordance with the present invention.

It should be noted that in accordance with the present invention end-to-end Ethernet connectivity is maintained because EOAN fiber ring **100** and the optical switches desirably are Layer **1** specific and transparent within the system. Thus, as noted above, the optical switches (e.g., optical switches **206** and **232-234**) preferably are used to simply transmit raw bits over a dedicated channel at the physical layer.

As further illustrated in FIG. **4**, a user (such as user **228**, etc.) may place a telephone call via, for example, a dedicated channel via EOAN system **1**. For example, in order for user **228** to make a telephone call, user **228** sends voice data via LAN cable **240** to Ethernet switch **236**, which routes the voice data via LAN cable **244** to optical switch **232**. Optical switch **232** converts electrical signals to optical signals, multiplexes the optical signals, and transmits the voice data via a dedicated channel on transmitting fiber **248** via EOAN fiber ring **100**, which sends the voice data via a dedicated channel on receiving fiber **218** to optical switch **206** in EOAN NOC **76**. Optical switch **206** in turn de-multiplexes the optical signals, converts the optical signals to electrical signals, and transmits the voice data via LAN cable **220** to Ethernet switch **208**, which routes voice data via LAN cable **222** to PBX switch **210**. PBX switch **210** then converts the voice data using a suitable telecommunication protocol and sends the voice data via LAN cable **222** to Ethernet switch **208**, which routes the voice data via LAN cable **220** to optical switch **206**, which converts electrical signals to optical signals, multiplexes the optical signals, and transmits the voice data preferably via a dedicated channel on transmitting fiber **216** via fiber optic

ring **100**, which transmits the voice data in accordance with the telecommunication protocol to central office **12**, which de-multiplexes the optical signals, converts the optical signals to electrical signals, and connects the telephone call via PSTN **50** (the use of the telecommunication protocol and dedicated channels of fiber optic ring **100** for such purposes has been previously described).

In an alternate embodiment of the present invention, PBX switch **210** may also be coupled directly to central office **12** via a fiber optic cable or other connection. Thus, PBX switch **210** may route voice data to central office **12** without transmitting the voice data across EOAN fiber ring **100**. For instance, for user **228** to make a telephone call, user **228** may transmit voice data to PBX switch **210** in accordance with the description in the previous example. Upon receipt of the voice data, PBX switch **210** then converts the voice data using a suitable telecommunication protocol and routes the voice data in accordance with the telecommunication protocol to central office **12**, which connects the telephone call via PSTN **50**.

In accordance with the present invention, the data of a plurality of users may be sent over the same or dedicated channels while keeping the data of these users separate. Through the management system in EOAN NOC **76**, EOAN system **1** can provide consistent QoS and Class of Service (COS) to customers and users, securing transmission quality and bandwidth for applications, such as IP multicasting, IP unicasting, VoIP, streaming video, etc.

FIG. **5** is a diagram illustrating an exemplary embodiment of a client architecture for an EOAN system **1**. In accordance with the present invention, a plurality of users (such as user **228**, users **256-258**, etc.) may connect to EOAN fiber ring **100** via a network architecture that includes a plurality of transmission methods, such as FSO transmissions, microwave signals, fiber optic cables, etc. EOAN NOC **76** provides data switching and management functions as described above in conjunction with FIG. **4**. Fiber ring **100** connects a plurality of users, facilities, and/or devices and has the properties such as described in conjunction with FIG. **3A**. Users (such as user **228**, users **256-258**, etc.) are preferably single businesses and may include users, servers, switches, telephones, and/or other devices necessary for voice and data communications in a LAN or other data network. Such equipment may include legacy technology.

In accordance with the present invention, a plurality of data transmission equipment, such as FSO devices (e.g., FSO **276-278**, etc.) and transceivers (e.g., transceivers **284-286**, etc.), may be implemented at the client's site in order to provide data communications between users, facilities, and/or devices. Preferably FSO **276-278** are either P2P or P2M laser devices that support Ethernet signaling natively and provide a continuous optical connection. Transceivers **284-286** preferably transmit/receive microwave signals to and from users, transceivers, and/or other radio towers via P2P or P2M delivery methods. Optical switches **232** and **260-262** preferably are WDM or DWDM optical switches (such as Ciena Multiwave Metro, etc.), which can support a plurality of protocols (Ethernet, SONET, ATM, etc.) and interface rates (OC-3, OC-12, OC-48, OC-192, etc.) on each optical fiber. Ethernet switches **236**, **264-266** and **280-282** preferably are intelligent Ethernet switches (such as Extreme Networks Summit 4, etc.), which are Layer **2** switches that are Layer **3** aware, and designed for customer premise and short-haul fiber ring applications. Fibers, optical switch and Ethernet switches have the same properties as described in conjunction with FIG. **4**. Servers **268-270** (such as Unix server, Windows NT, Linux, etc.) preferably control and manage the transceiv-



ers. LAN cables **240**, **244**, **296-306**, **314-318**, and **322** preferably are standard LAN cables (e.g., CAT5 cable for Ethernet, etc.). Furthermore, as noted in conjunction with FIG. 4, Ethernet switches at client sites, such as Ethernet switches **236-238**, etc., may be managed directly via a terminal or remotely via a plurality of remote access methods, such as Telnet, SSH2, SNMP, browser-based, device management software (e.g., Extreme Networks ExtremeWare Vista), etc.

In order for one or more users (such as user **228**, users **256-258**, etc.) to connect via optical fiber to EOAN fiber ring **100**, the client architecture preferably includes one or more Ethernet switches (such as Ethernet switches **236**, **264-266**, etc.), one or more optical switches (such as optical switches **232** and **260-263**, etc.), and a plurality of network cabling (such as LAN cables, optical fibers, etc.). For example, user **228** requires at a minimum Ethernet switch **236**, LAN cable **240**, optical switch **232**, and fibers **248** and **252** to connect to EOAN fiber ring **100**. It should be noted that optical switches **232** and **260-262** are connected to EOAN fiber ring **100** via one or more pairs of optical fibers from a fiber grouping (e.g., a fiber optical lateral arrangement, such as previously described).

In accordance with a preferred embodiment of the present invention, users may communicate bi-directionally with each other (i.e., exchange data, send e-mail, make telephone calls, etc.) through EOAN fiber ring **100** via fiber optic transmission media, such as described earlier.

As illustrated in FIG. 5, in accordance with an alternate preferred embodiment of the present invention, client architecture of EOAN system may connect to one or more fiber optic rings via FSO technology. In order for one or more users (such as user **256**) to connect via FSO technology, the client architecture preferably includes one or more Ethernet switches (such as Ethernet switches **264** and **280**), one or more optical switches (such as optical switch **260**), a plurality of servers (such as servers **268-270**), a plurality of transceivers (such as transceivers **272-274**), a plurality of FSO devices (such as FSO **276-278**), and a plurality of network cabling (such as LAN cables **300-306**, etc.). As will be apparent to one skilled in the art, servers (the servers primarily existing to service the transceivers and FSO devices, as will be understood by those of skill in the art), transceivers, and FSO devices must be implemented in pairs in accordance with the present invention. For example, user **256** may be connected via LAN cable **314** to Ethernet switch **280**, which is connected via LAN cable **302** to server **270**, which is coupled via LAN cable **306** to transceiver **274**. Transceiver **274** is connected via cable **310** to FSO **278**, which transmits/receives optical signals **312** to and from FSO **276**, which is coupled via cable **308** to transceiver **272**, which is coupled via LAN cable **304** to server **268**, which in turn is coupled via LAN cable **300** to Ethernet switch **264**, which is connected via LAN cable **296** to optical switch **260**, which is connected via optical fibers **288** and **292** to EOAN fiber ring **100**. In accordance with the present invention, users may communicate bi-directionally with each other via, for example, dedicated channels via FSO technology.

It should be noted that in a preferred embodiment of the present invention, a server (e.g., server **270**), transceiver (e.g., transceiver **274**), and FSO device (e.g., FSO **278**) may be integrated in a plurality of combinations as proprietary equipment (such as Terabeam models 4200, 5200, 6200, etc.). Thus, network cabling, such as cables **308-310**, may include cabling for proprietary equipment (such as USB, serial, Ethernet, etc.). What is important is that, in accordance with such embodiments, a FSO link is provided to connect a user such as user **256** to the EOAN system.

As further illustrated in FIG. 5, in accordance with an alternate preferred embodiment of the present invention, a client architecture of an EOAN system may connect to one or more fiber optic rings via microwave technology. In order for one or more users (such as user **258**) to connect via microwave signals to EOAN fiber ring **100**, the client architecture preferably includes one or more optical switches (such as optical switch **262**), one or more Ethernet switches (such as Ethernet switch **266** and **282**), two or more microwave transceivers (such as transceivers **284-286**), and a plurality of network cabling (such as LAN cables **298** and **318**, etc.). For example, user **258** may be connected via LAN cable **316** to Ethernet switch **282**, which is coupled via LAN cable **322** to transceiver **286**. Transceiver **286** transmits/receives microwave signals to and from transceiver **284**, which is connected via LAN cable **318** to Ethernet switch **266**, which is connected via LAN cable **298** to optical switch **262**, which is coupled via fibers **290** and **294** to EOAN fiber ring **100**. In accordance with the present invention, users may communicate bi-directionally with each other via, for example, dedicated channels via microwave technology.

In accordance with the present invention, users may communicate bi-directionally with each other (i.e., exchange data, send e-mail, make telephone calls, etc.) through EOAN fiber ring **100** via FSO devices. For instance, in order for user **228** to transmit data to user **256**, user **228** preferably sends data via LAN cable **240** to Ethernet switch **236**, which routes data via LAN cable **244** to optical switch **232**, which converts electrical signals to optical signals, multiplexes the optical signals, and sends the data via, for example, a dedicated channel on transmitting fiber **248** via fiber optic ring **100**. Fiber optic ring **100** routes the optical signals via a dedicated channel on receiving fiber **218** to EOAN NOC **76**, which routes the data according in accordance with operations such as described above in conjunction with FIG. 4. EOAN NOC **76** routes the optical signals via, for example, a dedicated channel on transmitting fiber **216** via EOAN fiber ring **100**, which sends the optical signals to optical switch **260** via, for example, a dedicated channel on receiving fiber **292**. Optical switch **260** de-multiplexes the optical signals, converts the optical signals to electrical signals, and sends the data via LAN cable **296** to Ethernet switch **264**, which routes the data via LAN cable **300** to server **268**, which sends data via LAN cable **304** to transceiver **272**, transmits data via network cabling **308** to FSO **276**, which transmits optical signals **312** to FSO **278**, which then sends the data via network cabling **310** to transceiver **274**, which transmits data via LAN cable **306** to server **270**, which sends data via LAN cable **302** to Ethernet switch **280**, which routes data via LAN cable **314** to user **256**.

In accordance with the present invention, users may communicate bi-directionally with each other (i.e., exchange data, send e-mail, make telephone calls, etc.) through EOAN fiber ring **100** via microwave technology. For instance, in order for user **228** to transmit data to user **258**, user **228** preferably sends data via LAN cable **240** to Ethernet switch **236**, which routes data via LAN cable **244** to optical switch **232**, which converts electrical signals to optical signals, multiplexes the optical signals, and sends the data via, for example, a dedicated channel on transmitting fiber **248** via fiber optic ring **100**. Fiber optic ring **100** routes the optical signals via a dedicated channel on receiving fiber **218** to EOAN NOC **76**, which routes the data according in accordance with operations such as described above in conjunction with FIG. 4. EOAN NOC **76** routes the optical signals via, for example, a dedicated channel on transmitting fiber **216** via EOAN fiber ring **100**, which sends the optical signals to



25

optical switch 262 via a dedicated channel on receiving fiber 294. Optical switch 262 de-multiplexes the optical signals, converts the optical signals to electrical signals, and sends the data via LAN cable 298 to Ethernet switch 266, which routes the data via LAN cable 318 to transceiver 284, which converts optical signals to microwave signals and transmits the data via microwave signals 320 to transceiver 286, which converts microwave signals to optical signals and sends the data via LAN cable 322 to Ethernet switch 282, which in turn routes data via LAN cable 316 to user 258.

As further illustrated in FIG. 5, one or more users (such as user 228, etc.) may transmit data to one or more users (such as user 258, etc.) via, for example, dedicated channels via EOAN system 1. For example, user 228 may transmit data to users 256-258, and user 256 may transmit data to user 228 and 258, and user 258 may transmit data to user 228 and user 256. In accordance with the present invention, users may communicate bi-directionally with each other via, for example, dedicated channels via a plurality of technologies on EOAN system 1 (alternatively, VLAN/VMAN frame tags and the like may be utilized to segregate user data, while also implementing EOAN system 1 with a plurality of types of transmission types for connecting remote users to the fiber optic ring of the EOAN system, etc.).

It should be noted that while EOAN system 1 can involve the exchange of digital data at 100 Mbps, 1 Gbps, and 10 Gbps, EOAN system 1 can also use other, slower data rates (e.g., 1200 bps, 2400 bps, 9600 bps, 14.4 Kbps, etc.). Thus, EOAN system 1 is not limited to high-speed data rates, but can also communicate at data rates commensurate with the type of data being transmitted/received, the type of service being provided, the quality of service needed, etc.

Although the invention has been described in conjunction with specific preferred and other embodiments, it is evident that many substitutions, alternatives and variations will be apparent to those skilled in the art in light of the foregoing description. Accordingly, the invention is intended to embrace all of the alternatives and variations that fall within the spirit and scope of the appended claims. For example, it should be understood that, in accordance with the various alternative embodiments described herein, various systems, and uses and methods based on such systems, may be obtained. The various refinements and alternative and additional features also described may be combined to provide additional advantageous combinations and the like in accordance with the present invention. Also as will be understood by those skilled in the art based on the foregoing description, various aspects of the preferred embodiments may be used in various subcombinations to achieve at least certain of the benefits and attributes described herein, and such subcombinations also are within the scope of the present invention. All such refinements, enhancements and further uses of the present invention are within the scope of the present invention.

What is claimed is:

1. An method for operating an Ethernet Optical Area Network ("EOAN") extending over one or more metropolitan areas, comprising the steps of:

providing a fiber optic ring;

providing at least a first user facility coupled to the fiber optic ring, wherein the first user facility is coupled to the fiber optic ring via first and second Ethernet switches, first and second wireless transceivers and a first optical switch/multiplexer, wherein the first user facility is connected to the first Ethernet switch, and the first Ethernet switch is connected to the first wireless transceiver;

26

communicating signals wirelessly between the first wireless transceiver and the second wireless transceiver, wherein the second wireless transceiver is connected to the second Ethernet switch, the second Ethernet switch is connected to the first optical switch/multiplexer, and the first optical switch/multiplexer is connected to the fiber optic ring;

providing at least a second user facility coupled to the fiber optic ring, wherein the second user facility is coupled to the fiber optic ring via third and fourth Ethernet switches, third and fourth wireless transceivers and a second optical switch/multiplexer, wherein the second user facility is connected to the third Ethernet switch, and the third Ethernet switch is connected to the third wireless transceiver;

communicating signals wirelessly between the third wireless transceiver and the fourth wireless transceiver, wherein the fourth wireless transceiver is connected to the fourth Ethernet switch, and the fourth Ethernet switch is connected to the second optical switch/multiplexer, and the second optical switch/multiplexer is connected to the fiber optic ring;

coupling network management control information via a network operation center ("NOC") to and from the fiber optic ring, wherein the NOC is coupled to the fiber optic ring via a third optical switch/multiplexer and a fifth Ethernet switch, wherein a server is connected to the fifth Ethernet switch, the first Ethernet switch is connected to the third optical switch/multiplexer, and the third optical switch/multiplexer is connected to the fiber optic ring;

wherein the NOC includes a network management application running on the server for remotely managing the EOAN, the method further comprising the step of providing network management control information to the first, second, third, fourth and fifth Ethernet switches, wherein data is communicated between the first and second user facilities via a communication path directed by the first, second, third, fourth and fifth Ethernet switches based on the provided network management control information, wherein end-to-end Ethernet data communications are provided between the first and second facilities using an Ethernet protocol.

2. The method of claim 1, wherein the NOC sends network management commands to the Ethernet switches, wherein the network management commands allocate bandwidth between types of data communications over the fiber optic ring.

3. The method of claim 2, wherein voice communications are given a higher priority for data transmission over the fiber optic ring as compared to computer data communications.

4. The method of claim 3, wherein a predetermined level of Quality of Service (QoS) is provided for voice communications over the fiber optic ring.

5. The method of claim 1, wherein data is transmitted through the fiber optic ring using a plurality of wavelengths of light, wherein each wavelength provides a channel for data transmission via the fiber optic ring.

6. The method of claim 1, wherein data communications from the first user facility to the second user facility are routed to the NOC via the fiber optic ring and subsequently routed to the second user facility from the NOC via the fiber optic ring.

7. The method of claim 1, wherein voice data communications are transmitted via the fiber optic ring, wherein a particular voice data communication is transmitted from the first user facility to the NOC via an Ethernet protocol, wherein the NOC processes the particular voice data communication in



accordance with a telecommunications protocol, wherein the NOC transmits the particular voice data communication to a telephone company central office, wherein the telephone company central office connects the particular voice data communication to a remote user facility.

8. The method of claim 7, wherein the NOC transmits the particular voice data communication to the telephone company central office via a communication facility separate from the fiber optic ring.

9. The method of claim 7, wherein the NOC transmits the particular voice data communication to the telephone company central office via the fiber optic ring.

10. The method of claim 9, wherein data is transmitted through the fiber optic ring using a plurality of wavelengths of light, wherein each wavelength provides a channel for data transmission via the fiber optic ring, wherein one or more predetermined channels for data transmission are dedicated for communications with the telephone company central office via the fiber optic ring.

11. The method of claim 10, wherein at least a first channel for data transmission via the fiber optic ring is dedicated for communications with the telephone company central office via a telecommunications protocol, wherein at least a second channel for data transmission via the fiber optic ring is dedicated for communications between user facilities or other facilities coupled to the fiber optic ring via an Ethernet protocol.

12. The method of claim 1, wherein the EOAN comprises a plurality of fiber optic rings that are interconnected.

13. The method of claim 12, wherein at least a first fiber optic ring is interconnected with a second fiber optic ring, wherein the first fiber optic ring is coupled to user facilities and other facilities in a first municipality, and wherein the second fiber optic ring is coupled to user facilities and other facilities in a second municipality.

14. The method of claim 13, wherein a NOC coupled to the first fiber optic ring controls routing of data communications via the first and second fiber optic rings.

15. The method of claim 13, wherein data communications occur within and between the first and second municipalities in accordance with an Ethernet protocol.

16. The method of claim 12, wherein the first fiber optic ring is interconnected with the second fiber optic ring via a common NOC, a long-haul fiber connection, a microwave-based connection, or a free space optic connection.

17. The method of claim 1, wherein the first user transmits data to the fiber optic ring at least in part using a free space optic data transmission, wherein the second user transmits data to the fiber optic ring at least in part using a microwave data transmission, wherein a third user transmits data to the fiber optic ring at least in part using a fiber optic data transmission but not a free space optic data transmission or a microwave data transmission.

18. The method of claim 1, wherein the fiber optic ring comprises one or more pairs of fiber optics, wherein a first fiber of at least one pair of fibers transmits data in both directions around the fiber optic ring, wherein a second fiber of the at least one pair of fibers transmits in both directions around the fiber optic ring opposite the first direction.

19. The method of claim 18, wherein data transmissions may occur via the first direction or the second direction, wherein a redundant path for data transmissions via the fiber optic ring is provided.

20. The method of claim 18, wherein the fiber optic ring comprises a self-healing fiber optic ring.

21. *An method for managing a network extending over two or more geographic locations, comprising the steps of:*

*providing a fiber optic topology at a first geographic location, wherein the fiber optic network topology comprises two or more optical Ethernet switches interconnected with fiber optic cable, and wherein the fiber optic network topology is coupled to a wireless network topology via an optical Ethernet switch;*

*providing a wired Ethernet network topology located at a second geographic location, wherein the wired Ethernet network topology comprises two or more wired Ethernet switches interconnected with Ethernet wiring, and wherein the wired Ethernet network topology is coupled to the wireless network topology via a wired Ethernet switch;*

*communicating signals between the fiber optic network topology at the first geographic location and the wired Ethernet network topology located at the second geographic location via the optical Ethernet switch, the wireless network topology, and the wired Ethernet switch;*

*providing network management control information from a network operation center (NOC) to the fiber optic topology and the wired Ethernet topology;*

*wherein end-to-end data communications are provided between the first and second geographic locations via a communication path comprising the wireless network topology, wherein the communications path is directed by the the optical Ethernet switch and the wired Ethernet switch based on the provided network management control information.*

22. *The method of claim 21, wherein the NOC sends network management commands to the fiber optic topology and the wired Ethernet topology, wherein the network management commands allocate bandwidth between types of data communications.*

23. *The method of claim 22, wherein voice communications are given a higher priority for data transmission as compared to data communications.*

24. *The method of claim 23, wherein a predetermined level of Quality of Service (QoS) is provided for voice communications.*

25. *The method of claim 21, wherein data is transmitted over the fiber optic topology using a plurality of wavelengths of light, wherein each wavelength provides a channel for data transmission.*

26. *The method of claim 21, wherein data communications from the first geographical location to the second geographical location are routed to the NOC via the fiber optic topology and subsequently routed to the second geographical location from the NOC via the wired Ethernet topology.*

27. *The method of claim 21, wherein a voice communication is transmitted from the first geographic location to the NOC via an Ethernet protocol, wherein the NOC processes the voice in accordance with a telecommunications protocol, wherein the NOC transmits the voice communication to a telephone company central office, wherein the telephone company central office connects the voice communication to a remote user facility.*

28. *The method of claim 27, wherein the NOC transmits the voice communication to the telephone company central office via a communication facility distinct from the fiber optic topology.*

29. *The method of claim 27, wherein the NOC transmits the voice communication to the telephone company central office via the fiber optic topology.*



29

30. The method of claim 29, wherein data is transmitted through the fiber optic topology using a plurality of wavelengths of light, wherein each wavelength provides a channel for data transmission via the fiber optic topology, wherein one or more predetermined channels for data transmission are dedicated for communications with the telephone company central office via the fiber optic topology.

31. The method of claim 30, wherein at least a first channel for data transmission via the fiber optic topology is dedicated for communications with the telephone company central office via a telecommunications protocol, wherein at least a second channel for data transmission via the fiber optic topology is dedicated for communications between user facilities coupled to the fiber optic topology via an Ethernet protocol.

32. The method of claim 31, wherein the fiber optic topology comprises at least a first fiber optic ring interconnected with a second fiber optic ring.

33. The method of claim 32, wherein the first fiber optic ring is coupled to user facilities at the first geographic location and wherein the second fiber optic ring is coupled to user facilities at a third geographic location.

34. The method of claim 33, wherein a NOC coupled to the first fiber optic ring controls routing of data communications via the first and second fiber optic rings.

35. The method of claim 33, wherein data communications occur within and between the user facilities at the first and third geographic locations in accordance with an Ethernet protocol.

36. The method of claim 32, wherein the first fiber optic ring is interconnected with the second fiber optic ring via a common NOC, a long-haul fiber connection, a microwave-based connection, or a free space optic connection.

37. The method of claim 31, wherein a first user transmits data to the fiber optic topology at least in part using a free space optic data transmission, wherein a second user transmits data to the fiber optic topology at least in part using a microwave data transmission, wherein a third user transmits data to the fiber optic topology at least in part using a fiber optic data transmission but not a free space optic data transmission or a microwave data transmission.

30

38. The method of claim 31, wherein the fiber optic cable comprises one or more pairs of fiber optics, wherein a first fiber of at least one pair of fibers transmits data in both directions around the fiber optic topology, wherein a second fiber of the at least one pair of fibers transmits in both directions around the fiber optic topology opposite the first direction.

39. The method of claim 38, wherein data transmissions may occur via the first direction or the second direction, wherein a redundant path for data transmissions via the fiber optic topology is provided.

40. The method of claim 38, wherein the fiber optic topology comprises a self-healing fiber optic ring.

41. A method for operating an Ethernet Optical Area Network ("EOAN") extending over one or more metropolitan areas, comprising the steps of:

transmitting data via a fiber optic ring;

coupling data to/from at least a first user facility coupled to the fiber optic ring at least in part via a first Ethernet switch and a first wireless transceiver;

coupling data to/from at least a second user facility coupled to the fiber optic ring at least in part via a second Ethernet switch and a second wireless transceiver;

coupling network management control information via a network operation center ("NOC") to and from the fiber optic ring, wherein the NOC is coupled to the fiber optic ring at least in part via a third Ethernet switch, wherein a server is connected to the third Ethernet switch;

wherein the NOC includes a network management application running on the server for remotely managing the EOAN, the method further comprising the step of providing network management control information to the first, second and third Ethernet switches, wherein data is communicated between the first and second user facilities via a communication path directed by the first, second and third Ethernet switches based on the provided network management control information, wherein end-to-end Ethernet data communications are provided between the first and second facilities using an Ethernet protocol.

\* \* \* \* \*