



US00RE43336E

(19) **United States**
(12) **Reissued Patent**
Yamamoto

(10) **Patent Number:** **US RE43,336 E**
(45) **Date of Reissued Patent:** ***May 1, 2012**

(54) **PORTABLE ELECTRONIC TERMINAL APPARATUS HAVING A PLURALITY OF DISPLAYS**

(75) Inventor: **Katsuhisa Yamamoto**, Tokyo (JP)
(73) Assignee: **Ricoh Company, Ltd.**, Tokyo (JP)
(*) Notice: This patent is subject to a terminal disclaimer.

(21) Appl. No.: **12/911,350**
(22) Filed: **Oct. 25, 2010**

Related U.S. Patent Documents

Reissue of:
(64) Patent No.: **6,297,945**
Issued: **Oct. 2, 2001**
Appl. No.: **09/537,265**
Filed: **Mar. 29, 2000**

U.S. Applications:
(60) Continuation of application No. 11/877,458, filed on Oct. 23, 2007, now abandoned, which is a division of application No. 10/677,170, filed on Oct. 2, 2003, now Pat. No. Re. 40,204.

(30) **Foreign Application Priority Data**

Mar. 29, 1999 (JP) 11-086099

(51) **Int. Cl.**
G06F 1/16 (2006.01)
(52) **U.S. Cl.** **361/679.04**; 345/169; 345/905; 312/223.1; 248/917; 455/450
(58) **Field of Classification Search** 345/169, 345/905, 520; 312/223.1-223.6; 455/450, 455/557; 710/305; 711/201; 361/679-687, 361/724-727, 679.01, 679.06, 679.29, 679.22, 361/679.27, 679.05; 248/917, 125.1, 176.1
See application file for complete search history.

(56) **References Cited**

U.S. PATENT DOCUMENTS

5,138,590 A 8/1992 Masuda et al.
5,508,720 A 4/1996 DiSanto et al.
5,646,649 A 7/1997 Iwata et al.
5,673,170 A 9/1997 Register
6,125,286 A 9/2000 Jahagirdar et al.
6,134,103 A 10/2000 Ghanma
6,445,574 B1 9/2002 Saw et al.

(Continued)

FOREIGN PATENT DOCUMENTS

JP 6-292195 10/1994

(Continued)

Primary Examiner — Hung Duong
(74) *Attorney, Agent, or Firm* — Oblon, Spivak, McClelland, Maier & Neustadt, L.L.P.

(57) **ABSTRACT**

A portable electronic terminal apparatus includes a main body, an information input mechanism, a plurality of displays, a communications mechanism, and a flip panel. The main body has a hollow section. The information input mechanism inputs various kinds of information including data and instructions. Each of the displays shows the various kinds of information input through the input mechanism. The communications mechanism transmits and receives the various kinds of information input through the input mechanism. The flip panel is movably mounted on the main body and is configured to rotate to open and close about a side edge portion of the flip panel. This flip panel is retracted in the hollow section of the main body when the flip panel is closed. In addition, one of the displays is mounted on the flip panel.

33 Claims, 9 Drawing Sheets

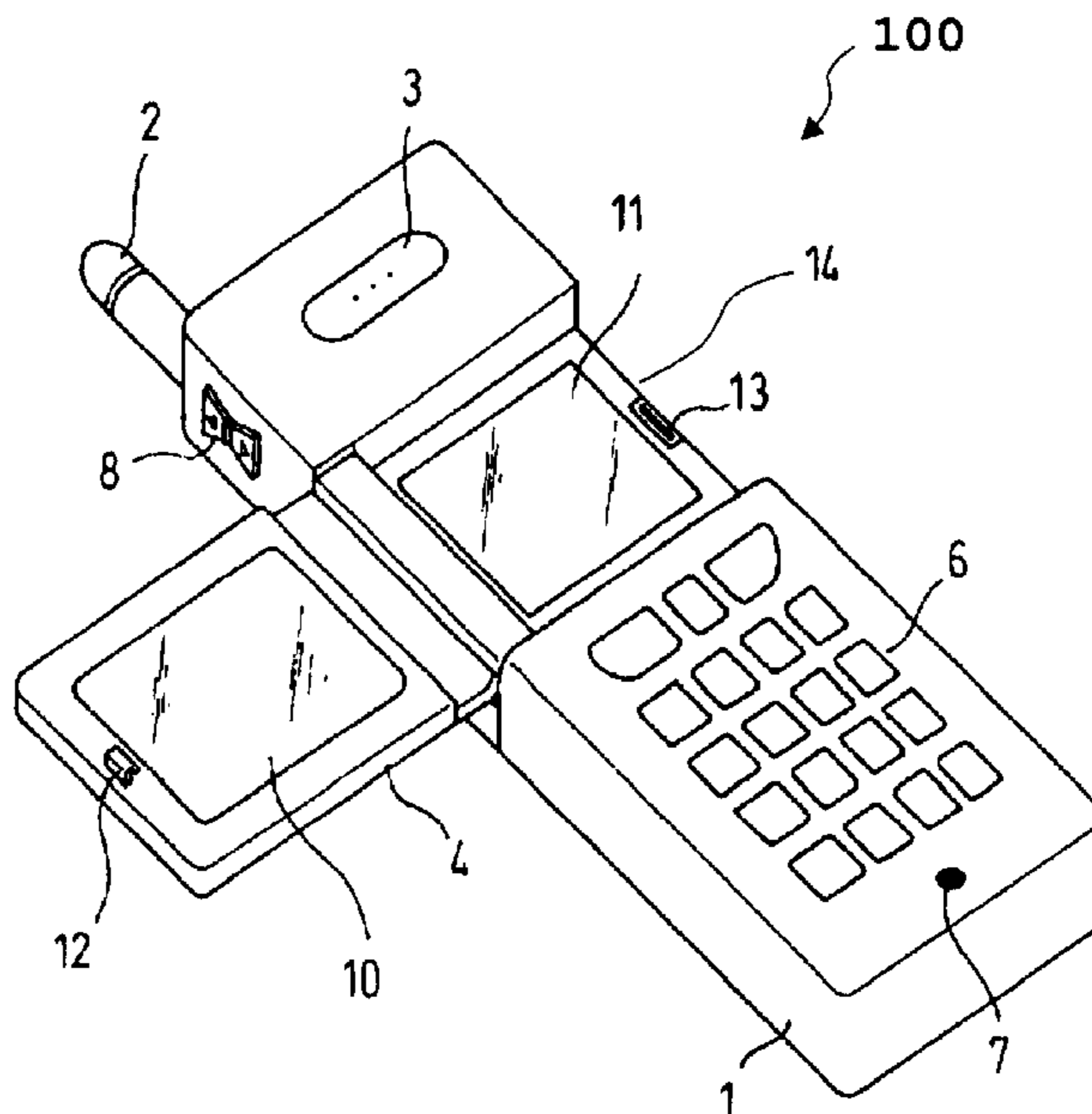

US RE43,336 E

Page 2

U.S. PATENT DOCUMENTS

2006/0256033 A1 11/2006 Chan et al.
2011/0169754 A1* 7/2011 Miyazawa et al. 345/173
2011/0188176 A1* 8/2011 Kim 361/679.01

FOREIGN PATENT DOCUMENTS

JP 07-050711 2/1995

JP	9-181801	7/1997
JP	09-261750	10/1997
JP	10-198291	7/1998
JP	10-224288	8/1998
JP	11-4301	1/1999
JP	11-017579	1/1999

* cited by examiner

Fig. 1
(prior art)

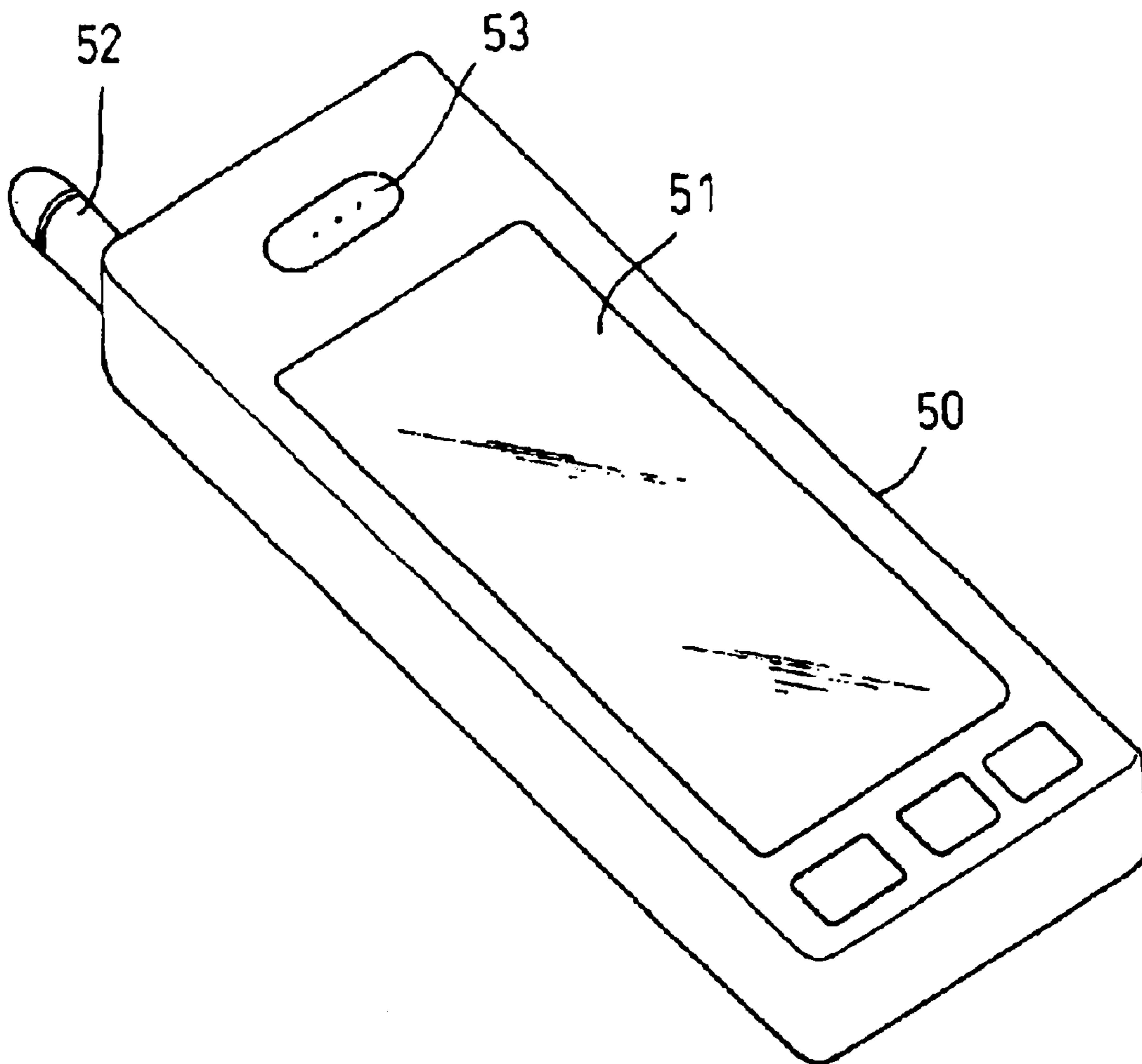

Fig. 2

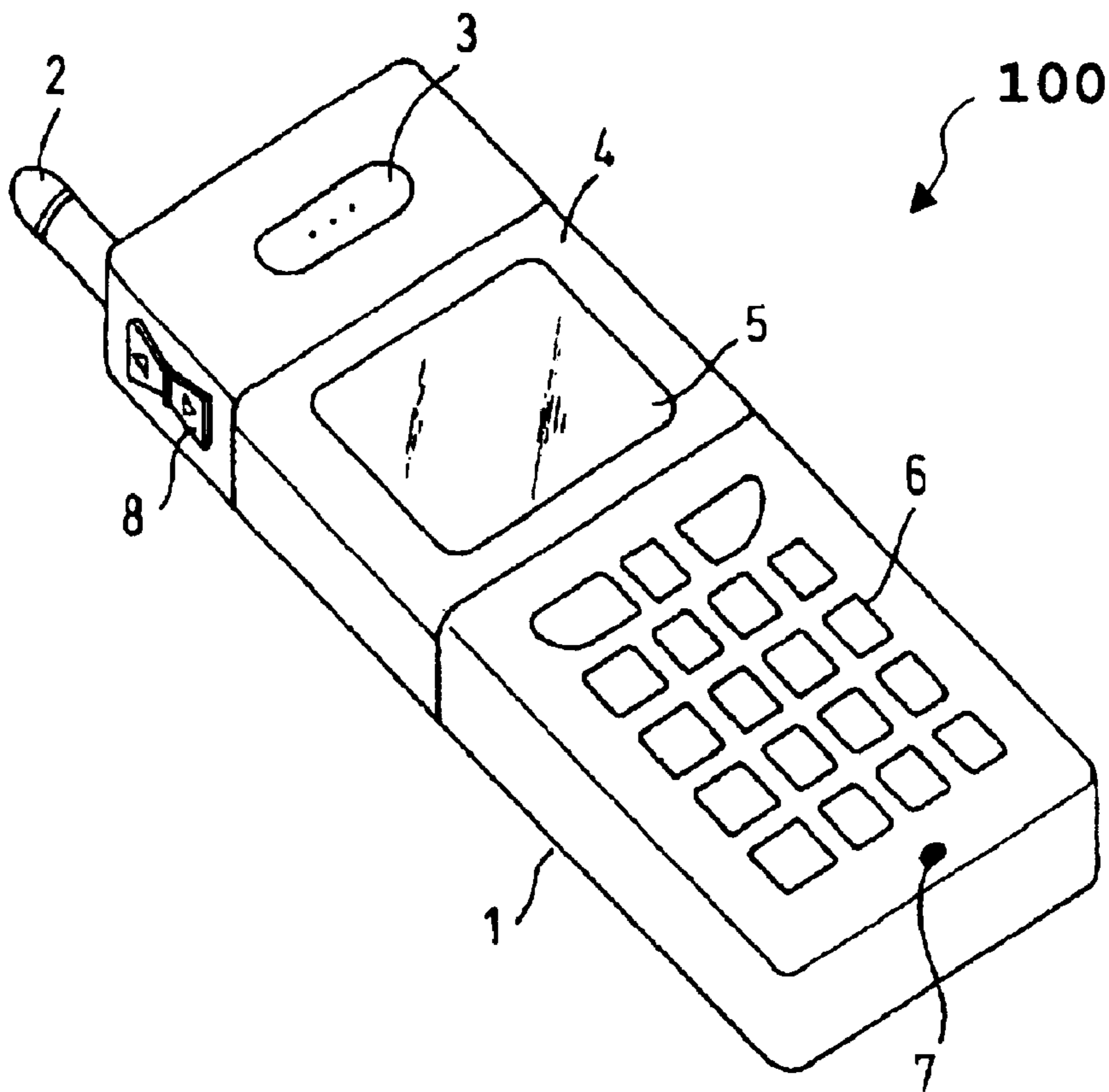

Fig. 3

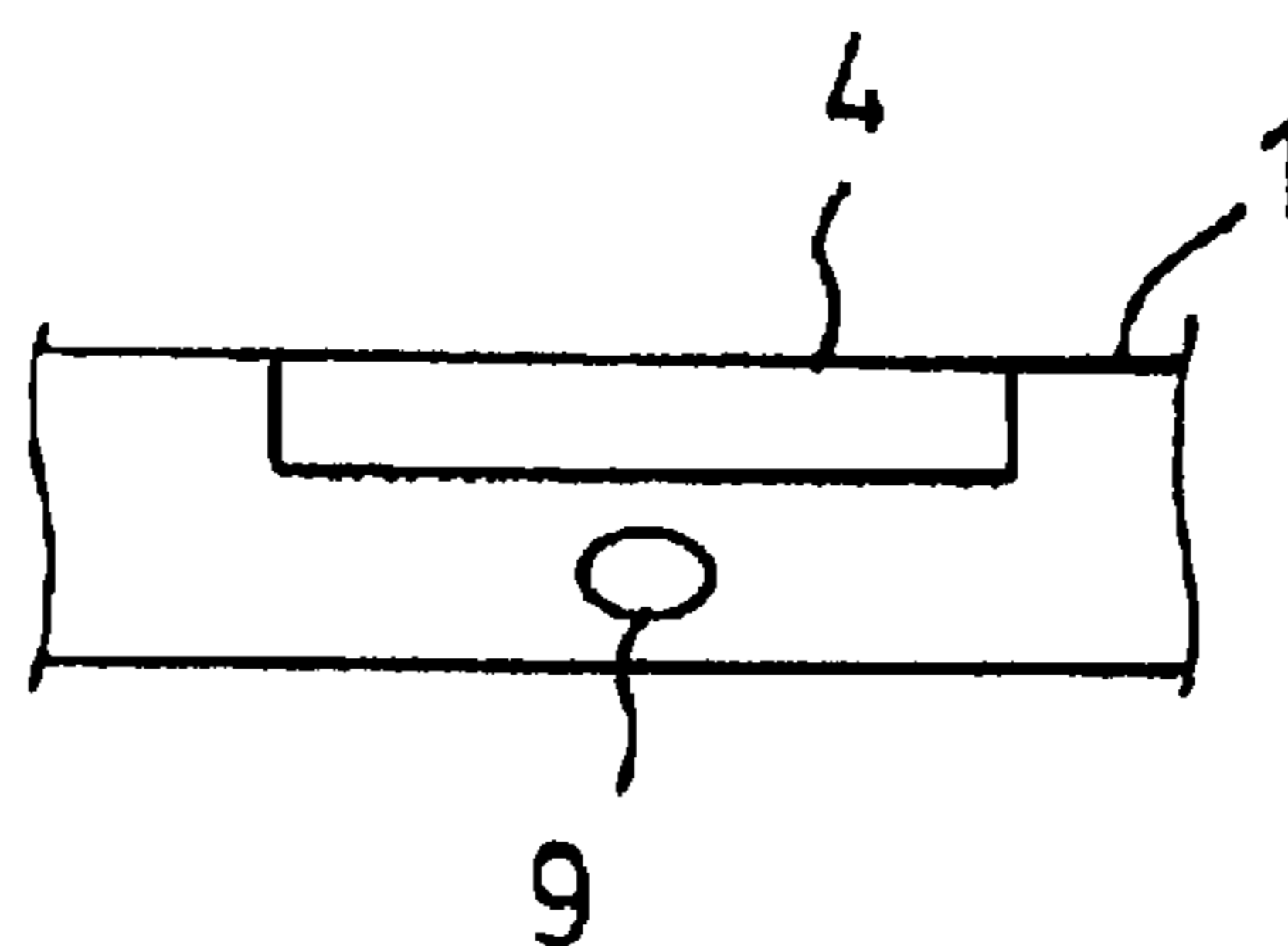

Fig. 4

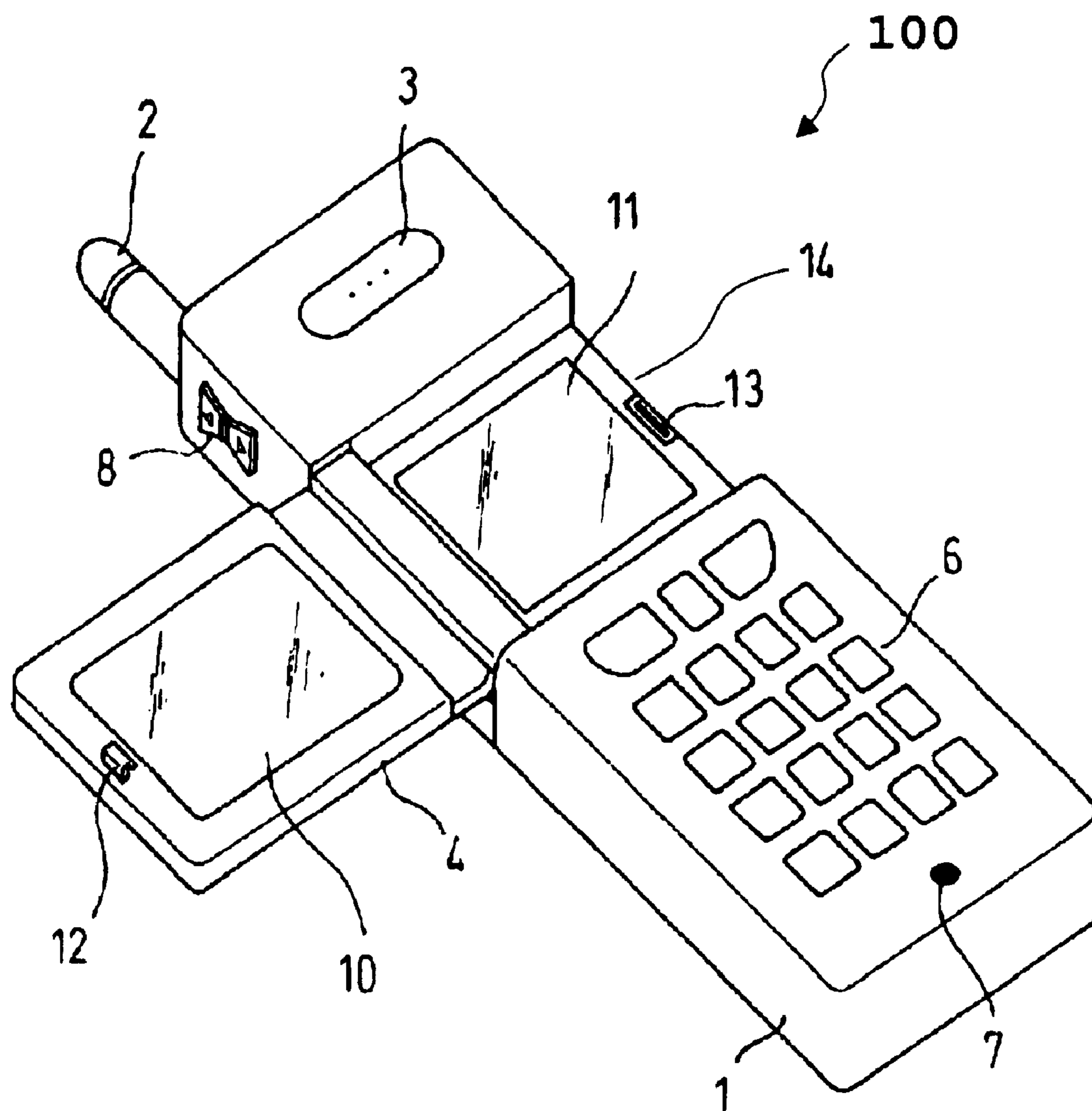

Fig. 5

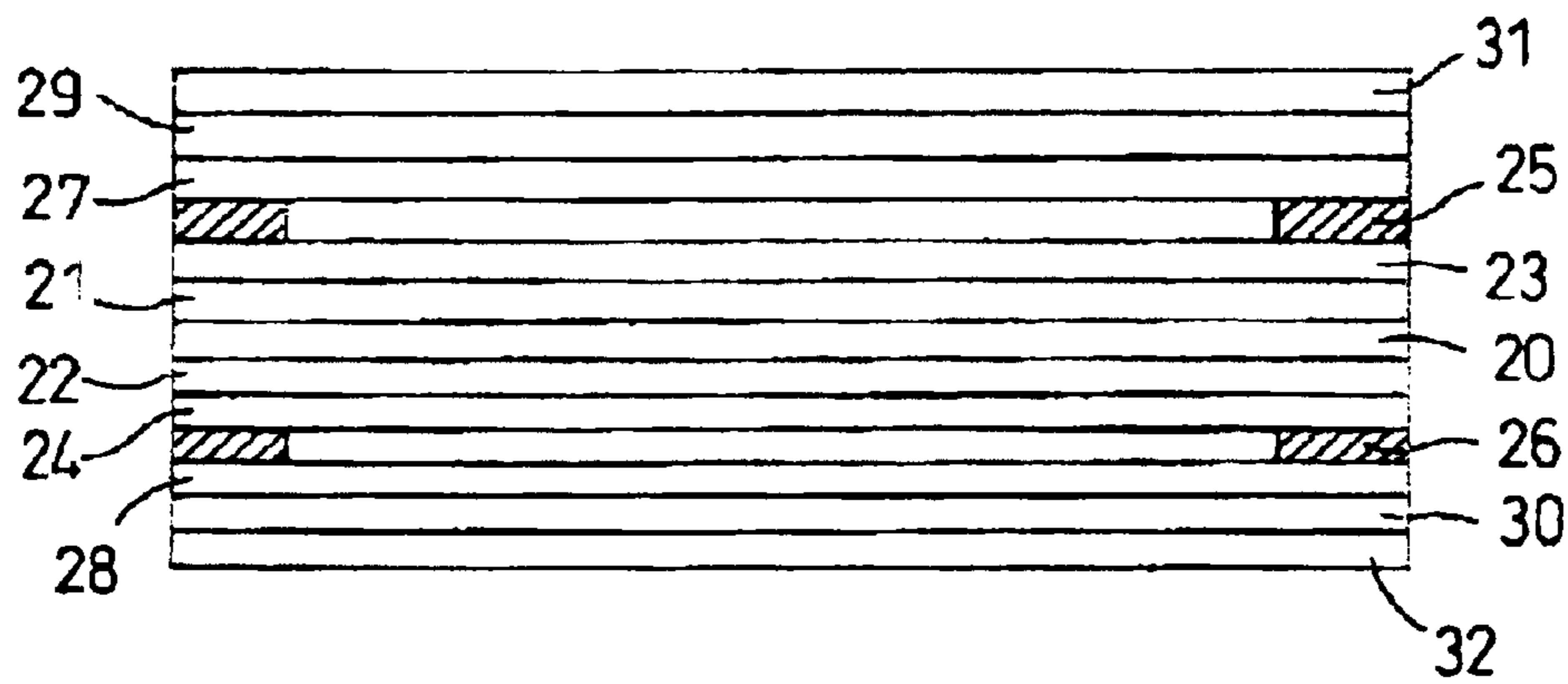

Fig. 6

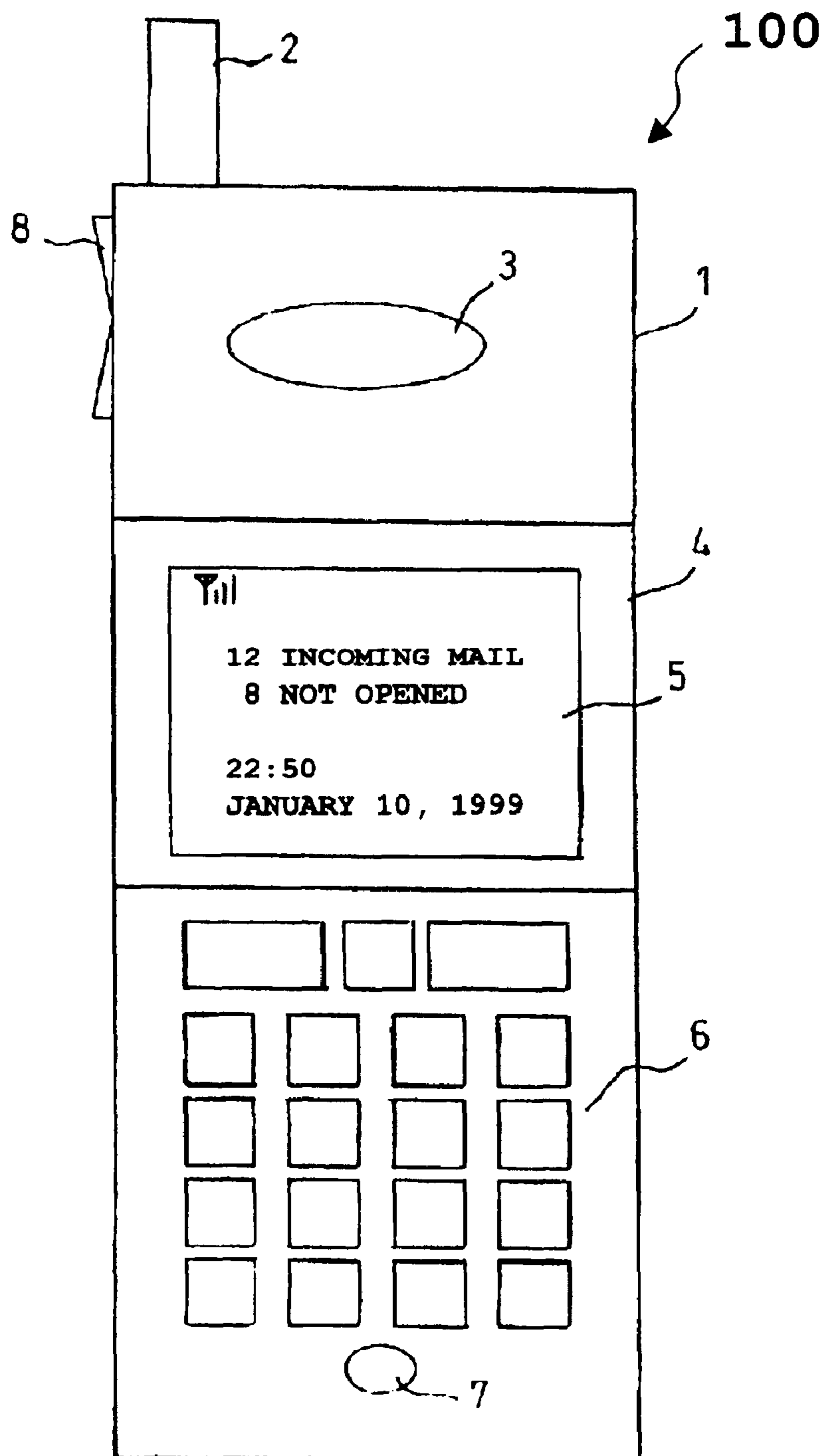

Fig. 7

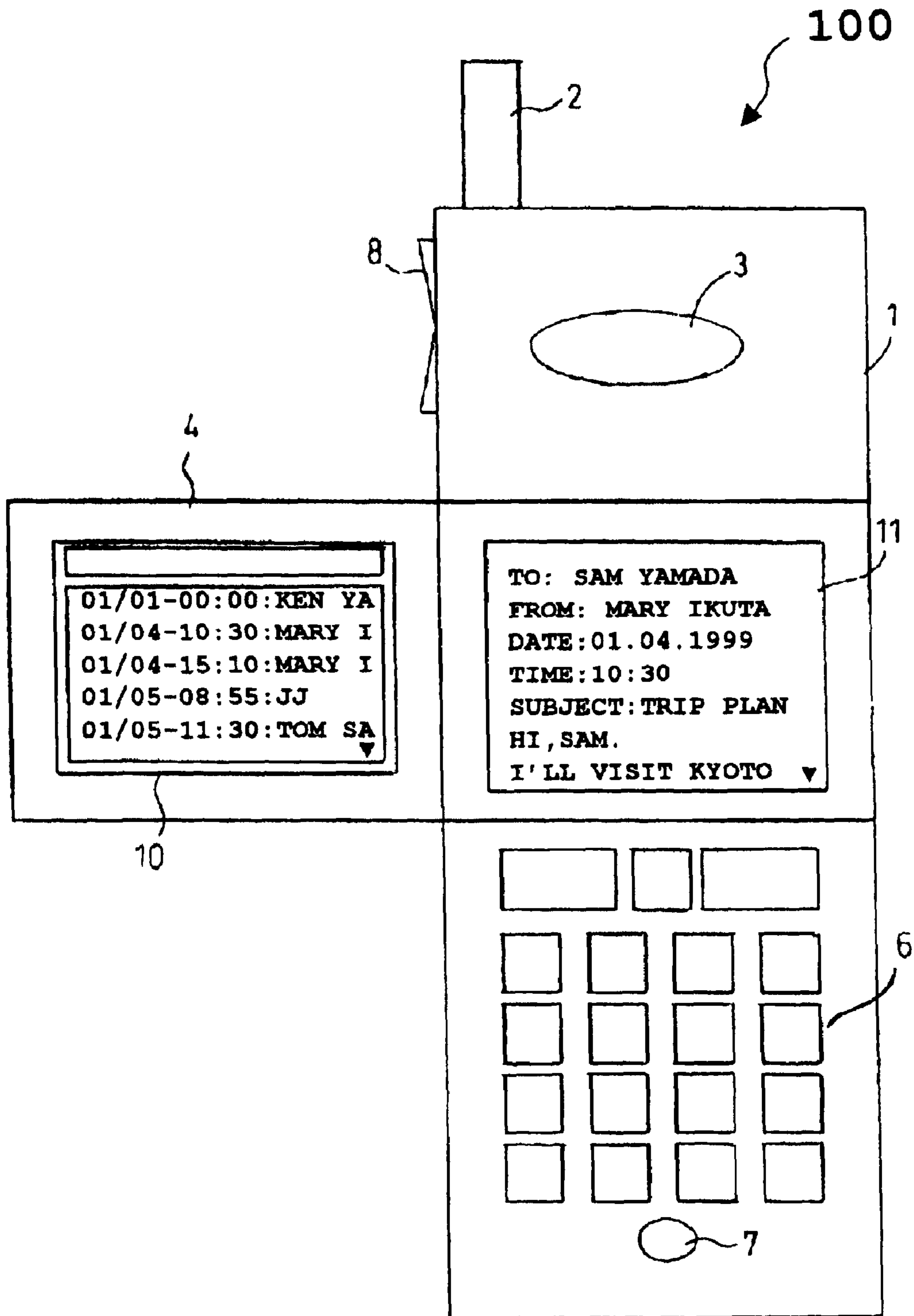

Fig. 8

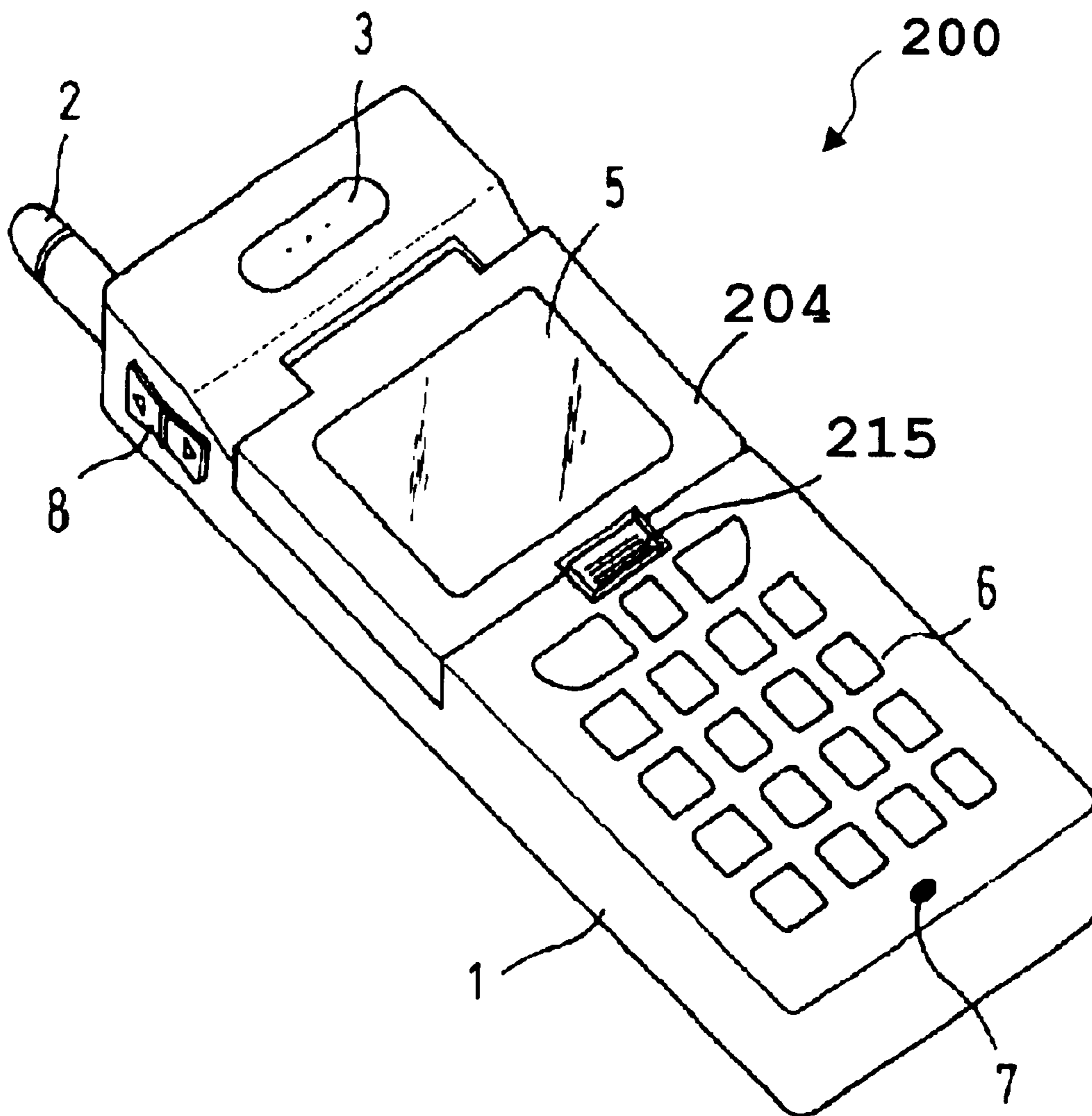

Fig. 9

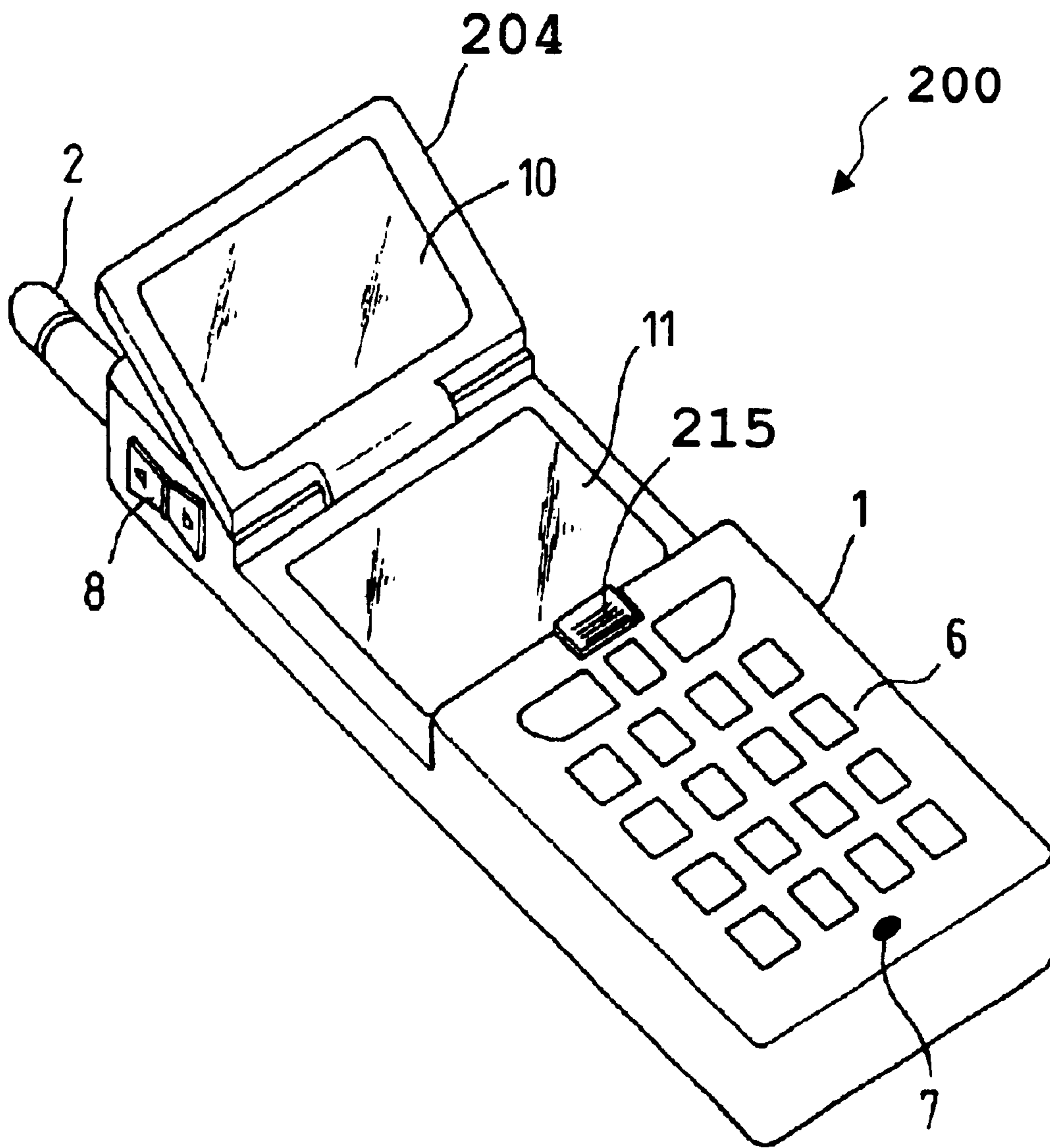

Fig. 10

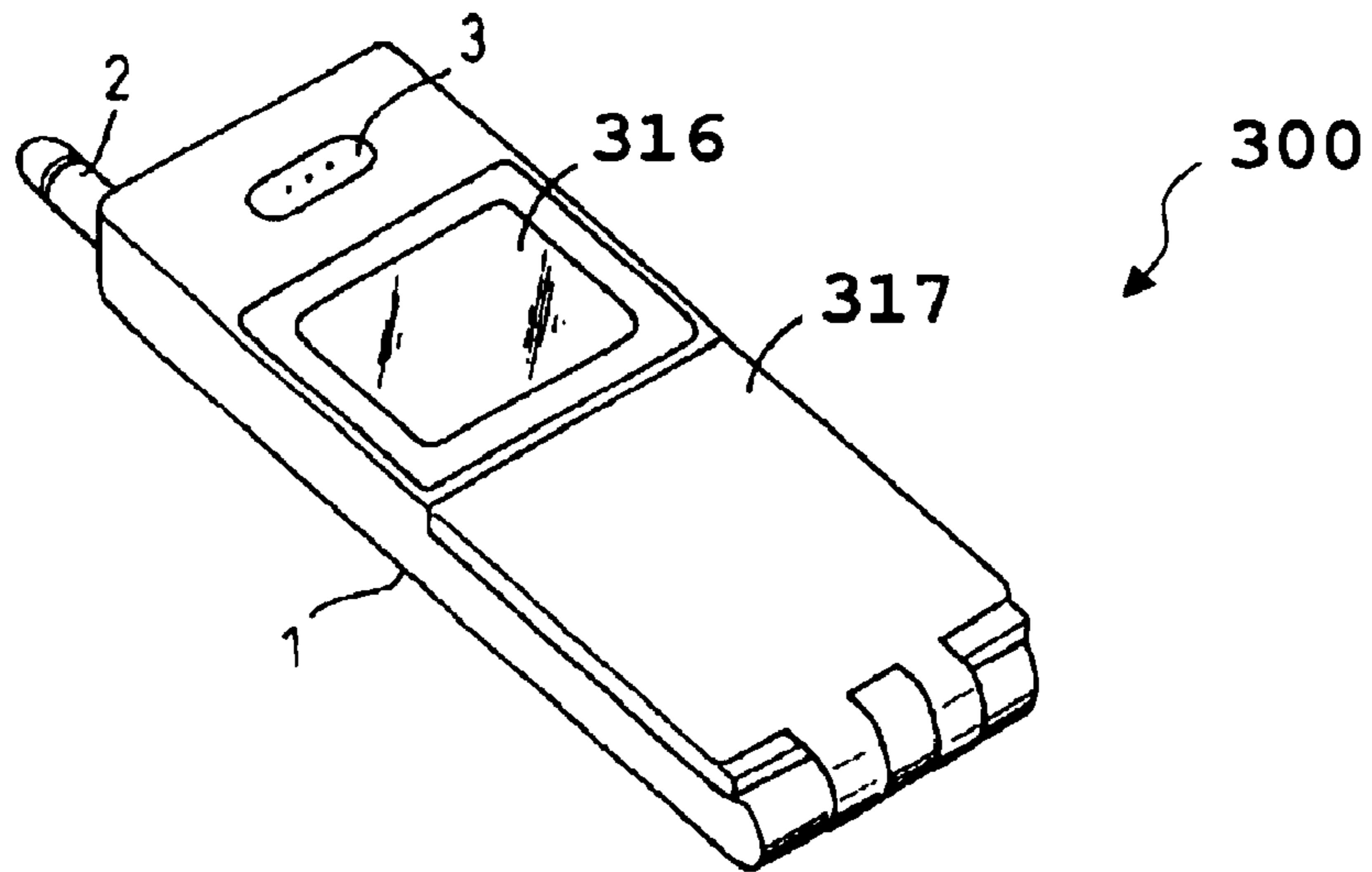
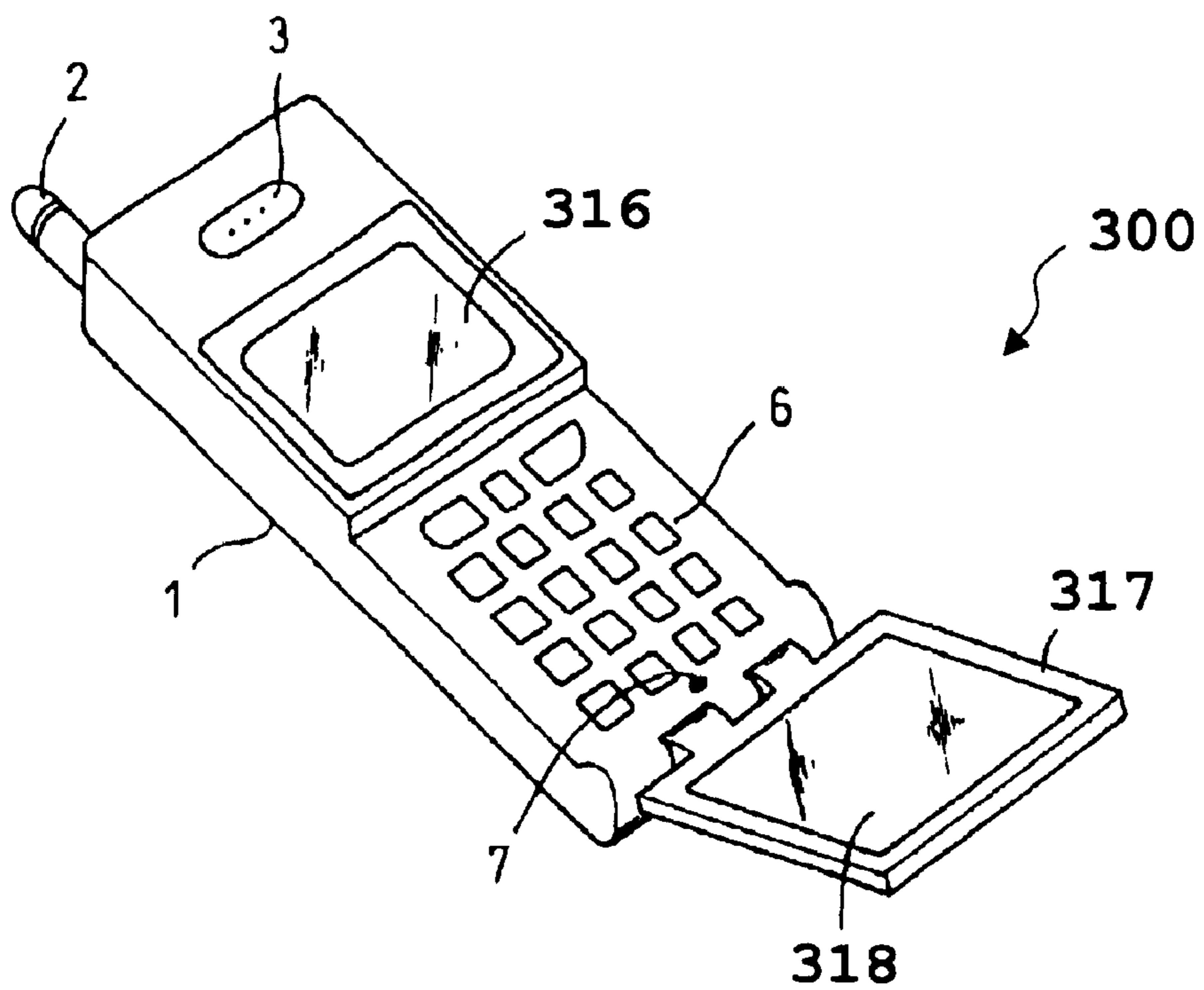

Fig. 11



1

**PORTABLE ELECTRONIC TERMINAL
APPARATUS HAVING A PLURALITY OF
DISPLAYS**

Matter enclosed in heavy brackets [] appears in the original patent but forms no part of this reissue specification; matter printed in italics indicates the additions made by reissue.

Notice: More than one reissue application has been filed for the reissue of U.S. Pat. No. 6,297,945. The reissue applications are application Ser. No. 10/677,170 (Parent reissue application), filed Oct. 2, 2003, divisional reissue application Ser. No. 11/877,458 now abandoned, and present continuation reissue application Ser. No. 12/911,350.

This application is a continuation of Ser. No. 11/877,458, filed Oct. 23, 2007 now abandoned which is a divisional of Ser. No. 10/677,170, filed Oct. 2, 2003 now U.S. Pat. No. Re. 40,204 which is a REISSUE of Ser. No. 09/537,265, filed Mar. 29, 2000 now issued U.S. Pat. No. 6,297,945.

CROSS-REFERENCE TO RELATED
APPLICATIONS

This application claims priority under 35 U.S.C. §119 to Japanese patent application No. JPAP11-086099 filed on Mar. 29, 1999, the entire contents of which are hereby incorporated by reference.

BACKGROUND OF THE INVENTION

1. Field of the Invention

The present invention generally relates to a portable electronic terminal apparatus, and more particularly to a portable electronic terminal apparatus which includes a flip panel and a plurality of displays.

2. Discussion of the Background

Recently, the amount of information for electronic apparatuses to exchange has greatly been increased through data communications verification because of rapid proliferation of portable communications equipment and an establishment of the corresponding infrastructure. In such a circumstance, portability as well as data communications capability has become more important, especially in a portable electronic apparatus (e.g., a cellular mobile phone, a personal assistant device, and the like).

In general, it is difficult to obtain both portability and visibility at the same time in a portable electronic apparatus. Such an apparatus needs to be lighter and smaller for increased portability. For instance, the area reserved for the display of a portable electronic apparatus can be reduced to increase portability. Typically, a portable electronic apparatus has a single display on which various kinds of information are selectively shown as user instructions; such as a screen scroll function, a function for switching over to another function, and so forth. In such a portable electronic apparatus, the user is usually required to perform complex manipulation of the display to finally read incoming mail and/or information received from information service providers.

As one example of the portable electronic apparatus, a mobile cellular phone, as illustrated in FIG. 1, is provided to overcome the above-mentioned problem. The mobile cellular phone of FIG. 1 includes a main body 51, a display 51, an antenna 52, and a loudspeaker 53. In this mobile cellular phone, a mechanical key pad is not used, instead a touch-sensitive

2

display is employed so as to fit in a relatively small area. Since the touch-sensitive display does not provide a tactile "click" response, the user is required to keep watching the display to make sure the input is entered properly. Therefore, the operability of the mobile cellular phone of FIG. 1 is reduced.

SUMMARY OF THE INVENTION

The present invention provides a novel portable electronic terminal apparatus which includes a main body, an information input mechanism, a plurality of displays, a communications mechanism, and a flip panel. The main body has a hollow section. The information input mechanism enables input of information, including data and instructions. A plurality of displays display the information input through the input mechanism. The communications mechanism transmits and receives the input information. The flip panel is movably mounted on the main body and is configured to rotate to open and close about a side edge portion of the flip panel. This flip panel is retracted in the hollow section of the main body when closed. In addition, one of the plurality of displays is mounted on the side of the flip panel that is exposed when closed.

One of the plurality of the displays may be mounted on a surface of the hollow section of the main body.

Another display may be mounted on another side of the flip panel.

One of the displays operates when the flip panel is closed, and the other display operates when the flip panel is opened.

Each of the displays may be a polymer-film liquid crystal display.

The displays may selectively be used by a user instruction input through the information input mechanism.

BRIEF DESCRIPTION OF THE DRAWINGS

A more complete appreciation of the present invention and many of the attendant advantages thereof will be readily obtained as the same becomes better understood by reference to the following detailed description when considered in connection with the accompanying drawings, wherein:

FIG. 1 is a diagram showing an overall view of a conventional mobile cellular phone;

FIG. 2 is a diagram showing an overall view of a portable electronic terminal apparatus according to an embodiment of the present invention;

FIG. 3 is a diagram showing the location of an open button of the portable electronic terminal apparatus of FIG. 2;

FIG. 4 is a diagram showing the portable electronic terminal apparatus of FIG. 2 with a flip panel opened;

FIG. 5 is a diagram showing a structure of a display included in the portable electronic terminal apparatus of FIG. 2;

FIGS. 6 and 7 are diagrams for showing an exemplary way of reading incoming mail on the portable electronic terminal apparatus of FIG. 2;

FIGS. 8 and 9 are diagrams showing a modified portable electronic terminal apparatus based on the portable electronic terminal apparatus of FIG. 2; and

FIGS. 10 and 11 are diagrams showing another modified portable electronic terminal apparatus based on the portable electronic terminal apparatus of FIG. 2.

DESCRIPTION OF THE PREFERRED
EMBODIMENTS

In describing preferred embodiments of the present invention illustrated in the drawings, specific terminology is

employed for the sake of clarity. However, the present invention is not intended to be limited to the specific terminology so selected and it is to be understood that each specific element includes all technical equivalents which operate in a similar manner.

Referring now to the drawings, wherein like reference numerals designate identical or corresponding parts throughout the several views, and more particularly to FIG. 2 thereof, there is illustrated a portable electronic terminal apparatus 100 according to an exemplary embodiment of the present invention. The portable electronic terminal apparatus 100 includes a main body 1, an antenna 2, a loudspeaker 3, a flip panel 4, a first display 5, a data entry panel 6, a microphone 7, and a button 8.

In this exemplary embodiment, the main body 1 has a front surface divided into upper, middle, and lower regions to which the loudspeaker 3, the flip panel 4, and the data entry panel 6 are provided, respectively. The antenna 2 is mounted inside the main body 1 so as to protrude from the top surface of the main body 1. The microphone 7 is mounted on a portion of the lower region closer to the bottom surface of the main body 1, and the button 8 is provided to a side surface of the main body 1 near the upper region. The flip panel 4 has a left side edge portion which is movably mounted in the left side edge of the middle region of the main body 1 so that the flip panel 4 can rotate to open and close about the left side edge portion. The first display 5 is mounted on the front surface of the flip panel 4. The data entry panel 6 includes a ten-key pad, for example, and other instruction keys. In addition, the portable electronic terminal apparatus 100 further includes an open button 9 for opening the flip panel 4. The open button 9 is mounted on a side surface of the main body 1 close to the flip panel 4, as illustrated in FIG. 3.

When the open button 9 is pressed, the flip panel 4 is opened, as illustrated in FIG. 4. As illustrated in FIG. 4, the portable electronic terminal apparatus 100 further includes a second display 10, a third display 11, a hook 12, and a dent 13. A hollow section 14 is created when the flip panel 4 is opened. The second display 10 is mounted on a rear side of the flip panel 4. The second display 10 may be integral with the first display 5. The third display 11 is mounted on a portion of the main body 1 opposite to the second display 10 with the flip panel 4 closed so as to appear next to the second display 10 with the flip panel 4 opened. The hook 12 is provided to a side edge of the rear surface of the flip panel 4 so as to hook up to the main body 1 with the dent 13 mounted on the main body 1. The hollow 14 is to receive the flip panel 4 when it is closed. For the open/close mechanism of the flip panel 4, the portable electronic terminal apparatus 100 is further provided with a hook receiver (not shown) and a spring (not shown). The hook receiver is mounted on a portion of the main body 1 closer to the dent 13 and is engaged with the hook 12 when the flip panel 4 is closed. The spring is mounted on a portion of the left side edge of the flip panel 4 so as to provide a tension to the flip panel 4 to open. The above-mentioned hook receiver is associated with the movement of the open button 9 so that the flip panel 4 is opened, as illustrated in FIG. 4, with the tension of the spring when the open button is pressed and is closed, as illustrated in FIG. 2, when the user closes the flip panel 4.

Each of the first and second displays 5 and 10 may be a thinner display (i.e., a polymer-film liquid crystal display) so that the flip panel 4 can be made thinner.

Referring to FIG. 5, an exemplary structure of a display when the first and second displays 5 and 10 are united in one piece is explained. In FIG. 5, an exemplary structure of a display includes a reflection plate 20, first polarizing plates 21

and 22, first transparent electrodes 23 and 24, liquid crystal layers 25 and 26, second transparent electrodes 27 and 28, phase plates 29 and 30, second polarizing plates 31 and 32. That is, the first display 5 includes the first polarizing plate 21, the first transparent electrode 23, the liquid crystal layer 25, the second transparent electrode 27, the phase plate 29, and the second polarizing plate 31. Further, the second display 10 includes the first polarizing plate 22, the first transparent electrode 24, the liquid crystal layer 26, the second transparent electrode 28, the phase plate 30, and the second polarizing plate 32. The first display 5 is mounted on a front surface of and the second display 10 is mounted on a rear surface of the reflection plate 20 so that a double-sided display is configured with the flip panel 4.

When the flip panel 4 is closed, the first display 5 is supplied with power but the second and third displays 10 and 11 are not supplied with power. That is, the second and third displays 10 and 11 can only be supplied with power when the flip panel 4 is opened. In addition, the user can set a condition in which the second and third displays 10 and 11 are not supplied with power through the data entry panel 6. Accordingly, the second and third displays 10 and 11 will not be supplied with power even when the flip panel 4 is accidentally opened. As a result, it becomes possible to avoid an increase of a power consumption by an accidental opening of the flip panel 4.

Referring to FIGS. 6 and 7, an exemplary way of using the portable electronic terminal apparatus 100 will be explained. When the portable electronic terminal apparatus 100 is not used, it stays in an idle status, as illustrated in FIG. 6. In the idle status, the flip panel 4 is closed and the first display 5 displays minimum information on it. The minimum information may include strength of the electric field (i.e., signal strength), the time of day, date, incoming mails, and so forth.

To read incoming mails, the user opens the flip panel 4 so that the second and third displays 10 and 11 show up, as illustrated in FIG. 7. In this case, the second display 10 shows a list of incoming mails and the third display 11 shows the contents of a selected incoming mail.

With the above-described structure, the portable electronic terminal apparatus 100 can conveniently display multiple pages of information. Moreover, it obviates the necessity for the user to enter the complex instructions through the data entry panel 6 to read incoming mails. Thus, the user can read incoming mails in much the similar way to read a book by turning pages.

Next, a first modification made to the portable electronic terminal apparatus 100 is explained with reference to FIGS. 8 and 9. In FIG. 8, a first modified portable electronic terminal apparatus 200 is shown. The first modified portable electronic terminal apparatus 200 of FIG. 8 is similar to the portable electronic terminal apparatus 100, except for a flip panel 204 and a knob 215.

The flip panel 204 of FIG. 8 is configured to have a top edge portion which is mounted on the top edge of the middle region of the main body 1. That is, the flip panel 204 can rotate about the top edge portion to open and close while the flip panel 4 of FIG. 2 rotates about the left side edge portion. The knob 215 is engaged with a bottom portion of the flip panel 204 when the flip panel 204 is closed and the flip panel 204 is retracted in the main body 1, as illustrated in FIG. 8. To open the flip panel 204, the user needs to push or slide the knob 215 to release its engagement with the bottom portion of the flip panel 204. Consequently, the flip panel 204 is opened towards the side of the loudspeaker 3, as illustrated in FIG. 9. Because of this direction of opening, the flip panel 204 is kept out of the way of the user's hand holding the main body 1.

5

Next, a second modification made to the portable electronic terminal apparatus 100 is explained with reference to FIGS. 10 and 11. In FIG. 10, a second modified portable electronic terminal apparatus 300 is shown. The second modified portable electronic terminal apparatus 300 of FIG. 10 is similar to the portable electronic terminal apparatus 100 of FIG. 2, except for a fixed display panel 316 and a flip panel 317. The fixed display panel 316 is fixed on the middle region of the main body 1. The flip panel 317 includes a secondary display 318, as illustrated in FIG. 11. The flip panel 317 is configured to have a bottom edge portion which is mounted on the bottom of the lower region of the main body 1. That is, the flip panel 317 can rotate about the bottom edge portion to open and close while the flip panel 4 of FIG. 2 rotates about the left side edge portion. With this configuration, the data entry panel 6 can be protected by the flip panel 317 when it is closed and both of the data entry panel 6 and the secondary display 318 will show up when the flip panel 317 is opened. Thus, the display size can be extended without increasing the size of the terminal apparatus.

Numerous additional modifications and variations of the present invention are possible in the light of the above teachings. It is therefore to be understood that within the scope of the appended claims, the present invention may be practiced otherwise than as specifically described herein.

What is claimed as new and is desired to be secured by Letters Patent of the United States is:

[1. A portable electronic terminal apparatus, comprising:
a main body having a hollow section;
an information input mechanism by which information including data and instructions can be input;
a plurality of displays which display said input information on a plurality of display screens;
a communications mechanism which transmits and receives said input information; and
a flip panel movably mounted on said main body and configured to rotatably open and close about a side edge portion of said flip panel, said flip panel being retracted into said hollow section of said main body when closed, wherein one of said plurality of displays is mounted on a side of said flip panel display screen that is exposed when closed.]

[2. The apparatus as defined in claim 1, wherein another one of said plurality of displays is mounted on a surface in said hollow section of said main body.]

[3. The apparatus as defined in claim 1, wherein another one of said plurality of displays is mounted on another side of said flip panel.]

[4. The apparatus as defined in claim 1, each of said plurality of displays is a polymer-film liquid crystal display.]

[5. The apparatus as defined in claim 1, wherein said plurality of displays are selectively used by a user instruction input through said information input mechanism.]

[6. The apparatus as defined in claim 3, wherein said one of said plurality of displays operates when said flip panel is closed, and said other one of said plurality of displays operates when said flip panel is opened.]

[7. A portable electronic terminal apparatus, comprising:
a main body having a hollow section;
an information input mechanism by which information including data and instructions can be input;
display means for displaying a plurality of displays of said input information on a plurality of display screens;
a communications mechanism which transmits and receives said input information; and
flip panel means for movably mounted on said main body and for rotatably opening and closing about a side edge

6

portion of a flip panel, said flip panel being retracted into said hollow section of said main body when closed, wherein one of said plurality of display means is mounted on a side of said flip panel display screen that is exposed when closed.]

[8. The apparatus as defined in claim 7, wherein another one of said plurality of display means is mounted on a surface in said hollow section of said main body.]

[9. The apparatus as defined in claim 7, wherein another one of said plurality of display means is mounted on another side of said flip panel.]

[10. The apparatus as defined in claim 7, each of said plurality of display means is a polymer-film liquid crystal display.]

[11. The apparatus as defined in claim 7, wherein said plurality of display means are selectively used by a user instruction input through said information input mechanism.]

[12. The apparatus as defined in claim 9, wherein said one of said plurality of display means operates when said flip panel is closed, and said other one of said plurality of display means operates when said flip panel is opened.]

*13. A portable electronic terminal apparatus, comprising:
a body having a hollow section;
an information input unit configured to input data and instructions;*

a plurality of displays which display said input information on a plurality of display screens;

a communications unit configured to transmit and receive said input information; and

a flip panel movably mounted on said body and configured to rotatably open and close about an edge portion of said flip panel, said flip panel being retracted into said hollow section of said body if the flip panel is closed,

wherein a first display of said plurality of displays is mounted on a first side of said flip panel that is exposed if the flip panel is closed.

14. The apparatus as defined in claim 13, wherein the information input unit is mounted on a surface in said hollow section of said body.

15. The apparatus as defined in claim 13, wherein a second display of said plurality of displays is mounted on a second side of said flip panel that is hidden if the flip panel is closed.

16. The apparatus as defined in claim 13, each of said plurality of displays is a polymerfilm liquid crystal display.

17. The apparatus as defined in claim 13, wherein said plurality of displays are selectively used by a user instruction input through said information input unit.

18. The apparatus as defined in claim 15, wherein first display of said plurality of displays operates if said flip panel is closed, and said second display of said plurality of displays operates if said flip panel is opened.

19. The apparatus as defined in claim 15, wherein the second display faces the information input unit if the flip panel is closed.

20. The apparatus as defined in claim 13, wherein the flip panel rotates around a side edge of the body.

21. The apparatus as defined in claim 13, wherein the hollow section in the body is bounded by an end wall.

22. The apparatus as defined in claim 21, wherein the end wall of the hollow section is adjacent to a hinge side of the flip panel.

23. The apparatus as defined in claim 13, further comprising:

an adjustment unit configured to reduce power supplied to the first display if the flip panel is open and the apparatus is powered on.

24. A portable electronic terminal apparatus, comprising:
a body having a hollow section;
an information input unit configured to input data and instructions;

display means for displaying a plurality of displays of said input information on a plurality of display screens;

a communications unit configured to transmit and receive said input information; and

flip panel means for rotatably opening and closing a flip panel about an edge portion of the body, said flip panel being retracted into said hollow section of said body if the flip panel is closed,

wherein a first display of said plurality of display means is mounted on a side of said flip panel that is exposed if the flip panel is closed.

25. The apparatus as defined in claim 24, wherein the information input unit is mounted on a surface in said hollow section of said body.

26. The apparatus as defined in claim 24, wherein a second display of said plurality of displays is mounted on a second side of said flip panel that is hidden if the flip panel is closed.

27. The apparatus as defined in claim 24, each of said plurality of displays is a polymerfilm liquid crystal display.

28. The apparatus as defined in claim 24, wherein said plurality of displays are selectively used by a user instruction input through said information input unit.

29. The apparatus as defined in claim 26, wherein first display of said plurality of displays operates if said flip panel is closed, and said second display of said plurality of displays operates if said flip panel is opened.

30. The apparatus as defined in claim 26, wherein the second display faces the information input unit if the flip panel is closed.

31. The apparatus as defined in claim 24, wherein the flip panel means is located on a side edge of the body.

32. The apparatus as defined in claim 24, wherein the hollow section in the body is bounded by an end wall.

33. The apparatus as defined in claim 32, wherein the end wall of the hollow section is adjacent to the flip panel means.

34. The apparatus as defined in claim 24, further comprising:

adjustment means for reducing power supplied to the first display if the flip panel is open and the apparatus is powered on.

35. A portable electronic terminal apparatus, comprising:
a body;
an information input unit configured to input data and instructions;

a plurality of displays which display said input information on a plurality of display screens;

a communications unit configured to transmit and receive said input information; and

a flip panel movably mounted on said body and configured to rotatably open and close about an edge portion of said flip panel, an outer surface of said flip panel being flush with an outer surface of said body if the flip panel is closed,

wherein a first display of said plurality of displays is mounted on a first side of said flip panel that is exposed if the flip panel is closed.

36. The apparatus as defined in claim 35, wherein the information input unit is mounted on a surface in a hollow section of said body.

37. The apparatus as defined in claim 35, wherein a second display of said plurality of displays is mounted on a second side of said flip panel that is hidden if the flip panel is closed.

38. The apparatus as defined in claim 35, each of said plurality of displays is a polymerfilm liquid crystal display.

39. The apparatus as defined in claim 35, wherein said plurality of displays are selectively used by a user instruction input through said information input unit.

40. The apparatus as defined in claim 38, wherein first display of said plurality of displays operates if said flip panel is closed, and said second display of said plurality of displays operates if said flip panel is opened.

41. The apparatus as defined in claim 38, wherein the second display faces the information input unit if the flip panel is closed.

42. The apparatus as defined in claim 35, wherein the flip panel rotates around a side edge of the body.

43. The apparatus as defined in claim 36, wherein the hollow section in the body is bounded by an end wall.

44. The apparatus as defined in claim 43, wherein the end wall of the hollow section is adjacent to a hinge side of the flip panel.

45. The apparatus as defined in claim 35, further comprising:

an adjustment unit configured to reduce power supplied to the first display if the flip panel is open and the apparatus is powered on.

* * * * *