

US00RE43310E

(19) **United States**
(12) **Reissued Patent**
Ishida et al.

(10) **Patent Number:** **US RE43,310 E**
(45) **Date of Reissued Patent:** ***Apr. 10, 2012**

(54) **BLOOD COLLECTING APPARATUS AND BLOOD COLLECTING METHOD USING BLOOD COLLECTING APPARATUS**

5,059,173 A * 10/1991 Sacco 604/80
5,098,371 A 3/1992 Juji et al.
5,348,539 A * 9/1994 Herskowitz 604/141
6,592,613 B1 * 7/2003 Ishida et al. 604/408

(75) Inventors: **Noboru Ishida**, Fujinomiya (JP);
Yoshihiro Yokoo, Fujinomiya (JP);
Hitoshi Kuroki, Fujinomiya (JP)

FOREIGN PATENT DOCUMENTS

EP 0 455 215 11/1991
EP 0 455 215 A2 11/1991
JP 63-132658 A 6/1988

(73) Assignee: **Terumo Kabushiki Kaisha**, Tokyo (JP)

(Continued)

(*) Notice: This patent is subject to a terminal disclaimer.

OTHER PUBLICATIONS

(21) Appl. No.: **12/371,247**

H. Olthuis et al., "A Simple Method to Remove Contaminating Bacteria During Venepuncture," *Vox Sanguinis International Journal of Transfusion Medicine*, 24th Congress of the International Society of Blood Transfusion, Abstract 1/2C-33 OP, Suppl 2, 1996, p. 113, S. Karger Medical and Scientific Publishers.

(22) Filed: **Feb. 13, 2009**

(Continued)

Related U.S. Patent Documents

Reissue of:

(64) Patent No.: **6,328,726**
Issued: **Dec. 11, 2001**
Appl. No.: **09/231,782**
Filed: **Jan. 15, 1999**

Primary Examiner — Manuel Mendez

(74) *Attorney, Agent, or Firm* — Buchanan Ingersoll & Rooney PC

(30) **Foreign Application Priority Data**

Jan. 16, 1998 (JP) 10-020394

(51) **Int. Cl.**
A61B 19/00 (2006.01)

(57) **ABSTRACT**

(52) **U.S. Cl.** **604/408**

(58) **Field of Classification Search** 604/408,
604/401, 501, 502, 503, 6.01-6.09, 6.11-6.12,
604/6.15, 6.16, 244, 410, 262

A blood collecting apparatus comprises a blood collecting needle **152**; the blood collecting bag, a first tube whose one end communicates with the blood collecting bag and other end communicates with the blood collecting needle, the branch portion provided on a portion of the first tube, a second tube connected with the branch portion at one end thereof and having a blood take-out port (sampling port); and a flexible resin bag including a third tube communicating with the second tube. The flexible resin bag is capable of accommodating air inside a part of the first tube between the branch portion and the blood collecting needle and air inside the second tube when the blood collecting apparatus is used.

See application file for complete search history.

(56) **References Cited**

U.S. PATENT DOCUMENTS

2,955,595 A * 10/1960 Semple 600/573
4,846,795 A * 7/1989 Minagawa 604/410

18 Claims, 14 Drawing Sheets

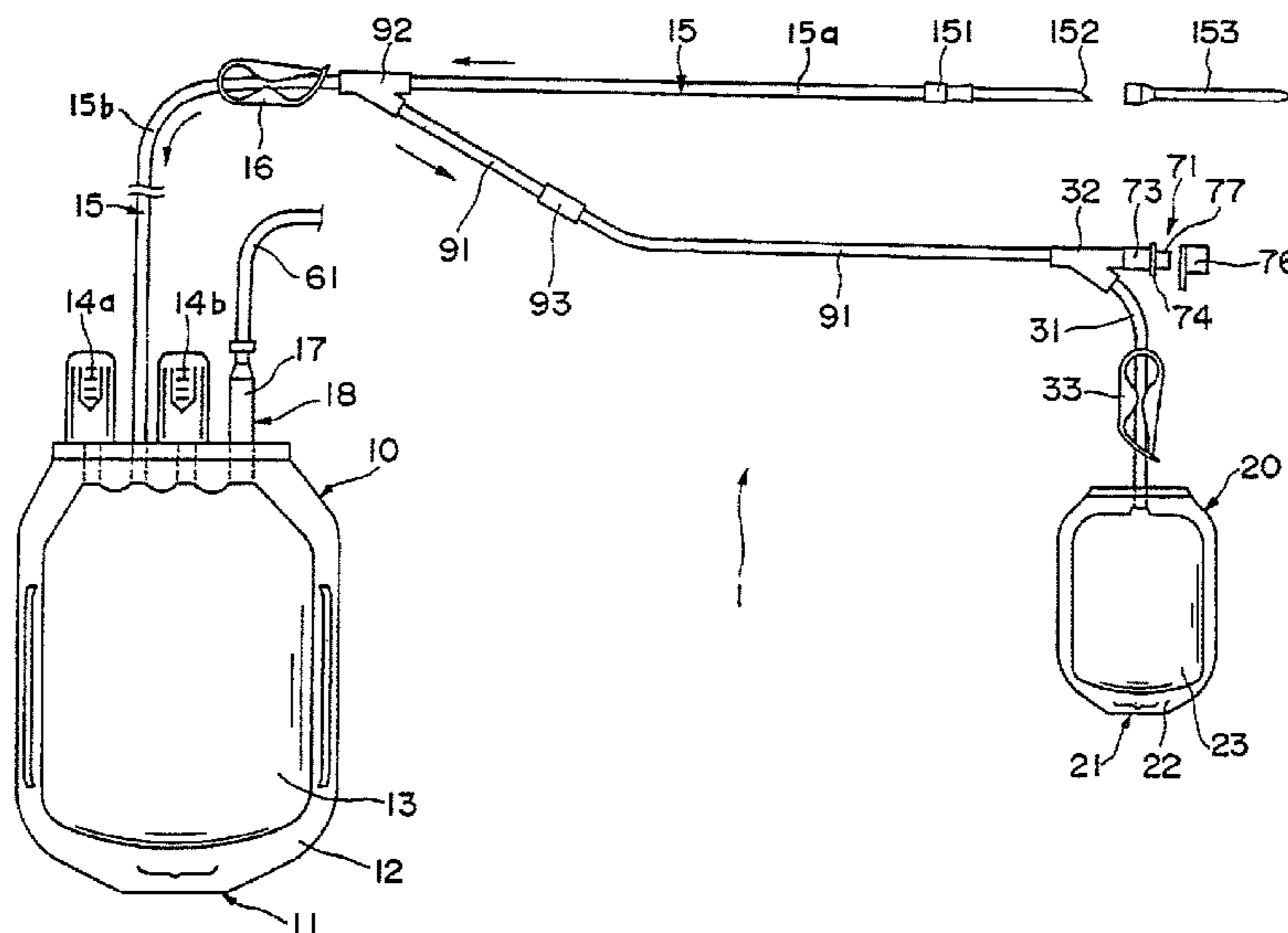

US RE43,310 E

Page 2

FOREIGN PATENT DOCUMENTS

JP	2-71728 A	3/1990
JP	2-167173 A	6/1990
JP	5-28341 U	4/1993
JP	8-173405 A	7/1996
WO	83/00813	3/1983
WO	WO 83/00813 A1	3/1983
WO	89/09025	10/1989
WO	WO 89/09025 A1	10/1989

OTHER PUBLICATIONS

“NIH Holds Microbial Contamination Workshop,” *Blood Bank Week*, Sep. 29, 1995, pp. 1-3. vol. 12, No. 36, American Association of Blood Banks.

“NIH Workshop Examines Bacterial Contamination of Blood Components,” *CCBC Newsletter*, Oct. 13, 1995, pp. 13-17, Council of Community Blood Centers.

* cited by examiner

FIG. 1

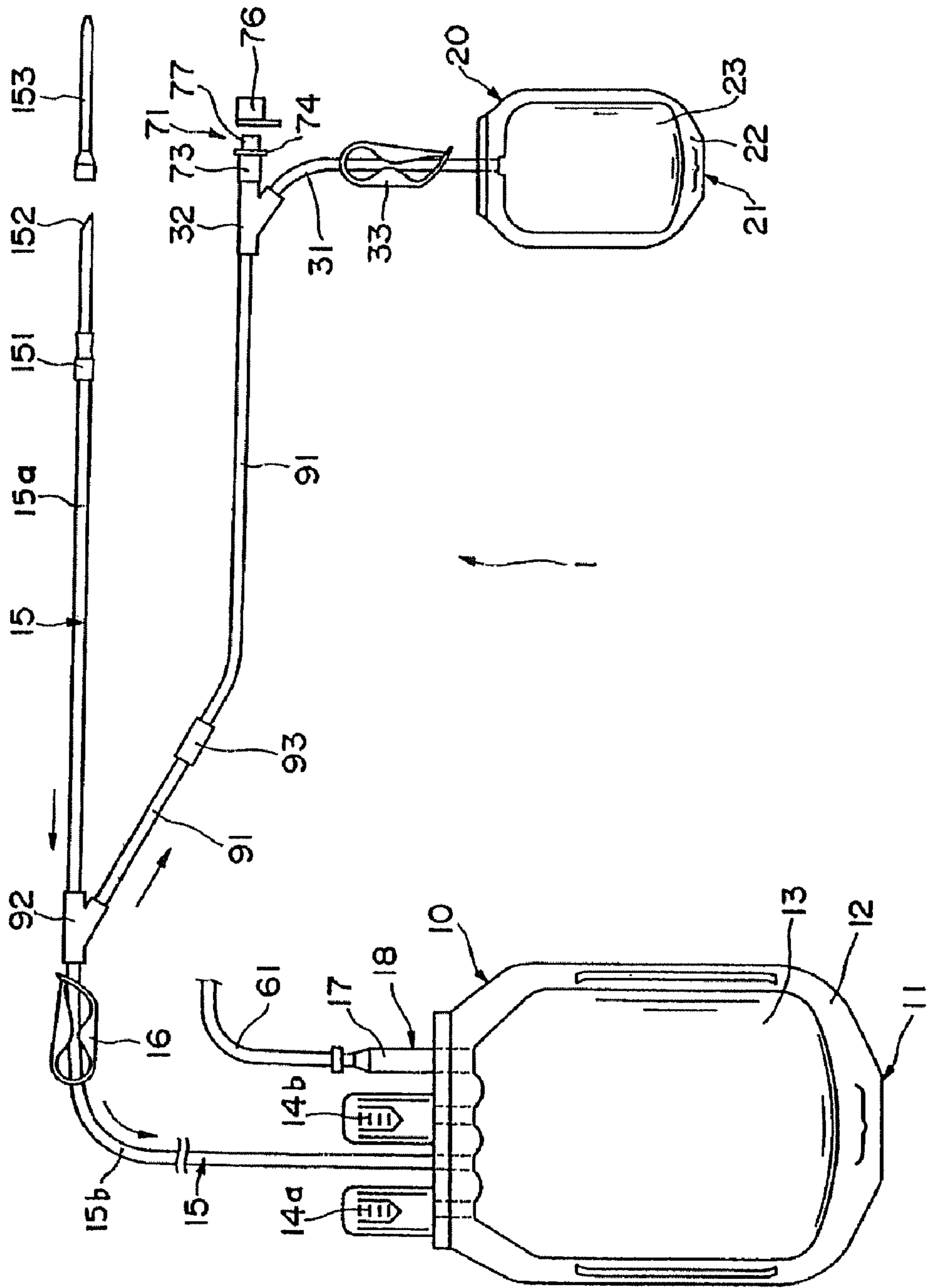

FIG. 2

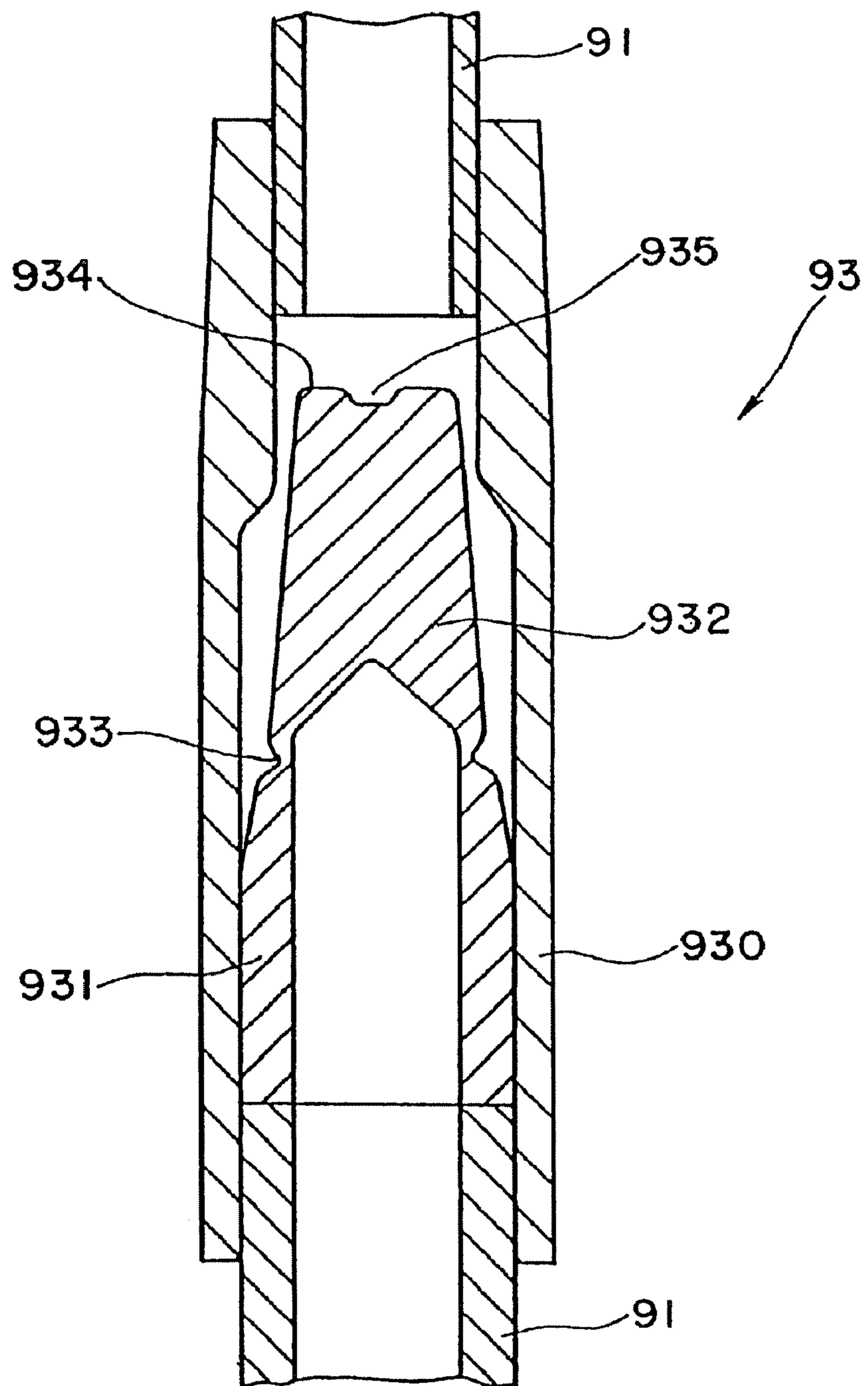

FIG. 3

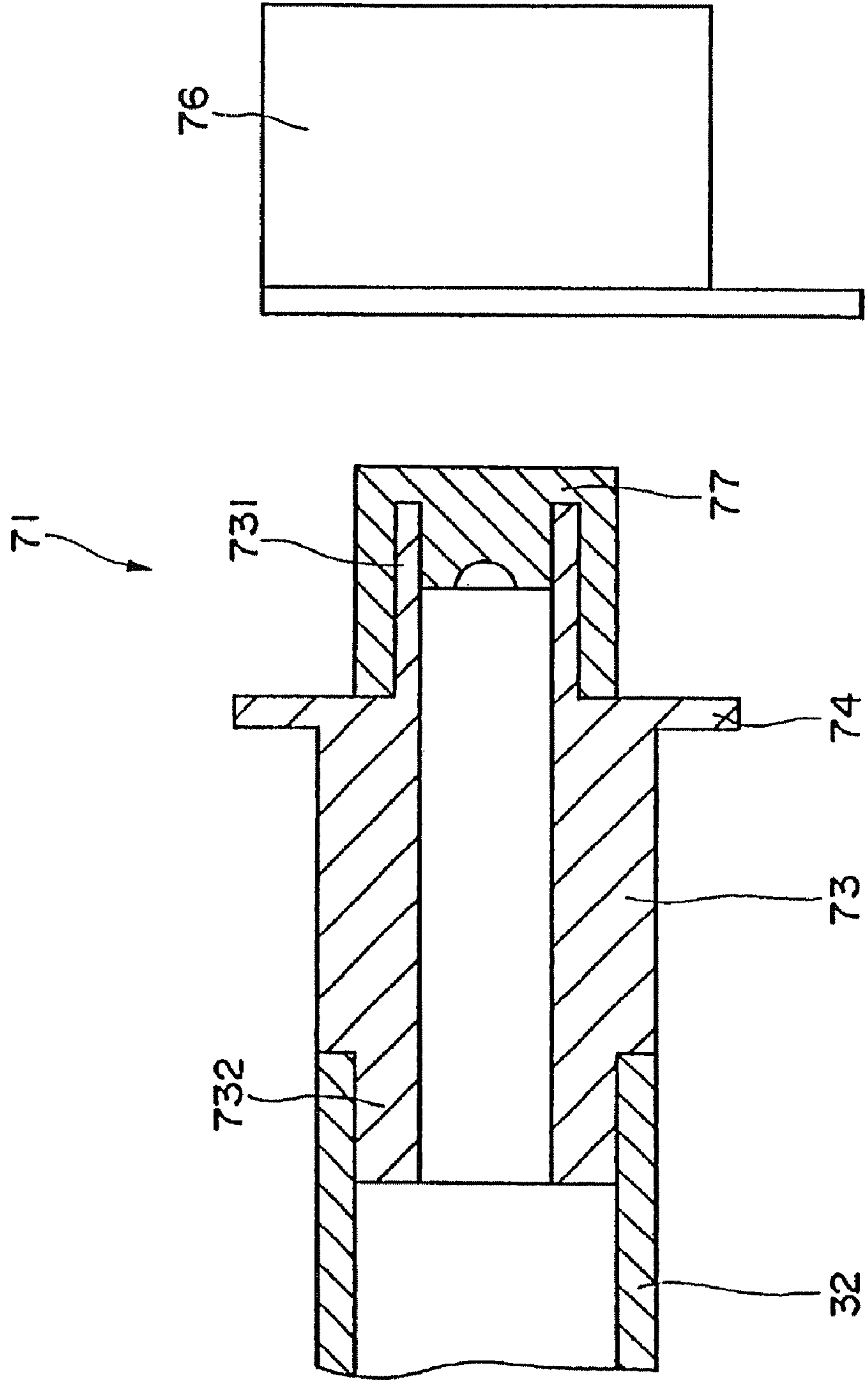

FIG. 4

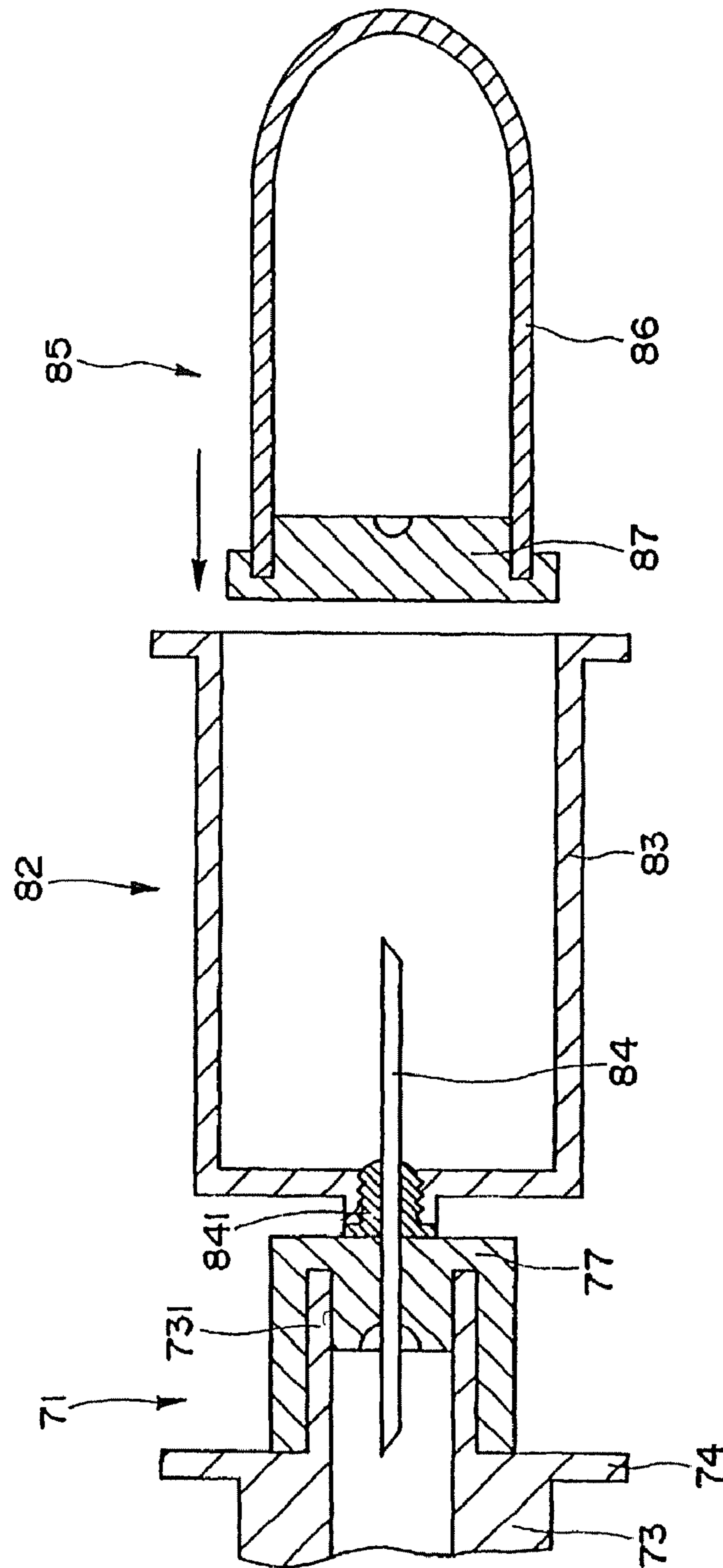

FIG. 5

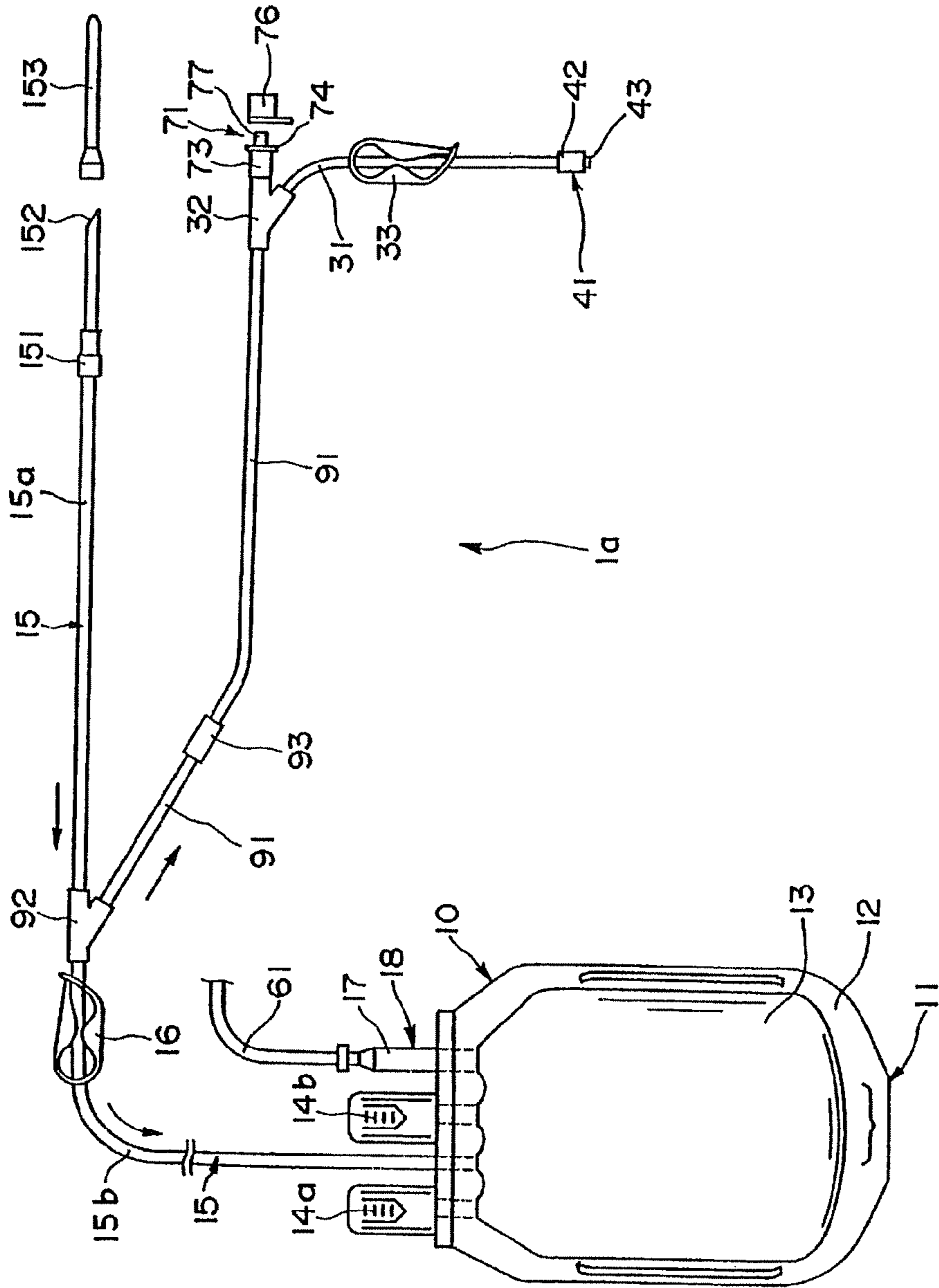

FIG. 6

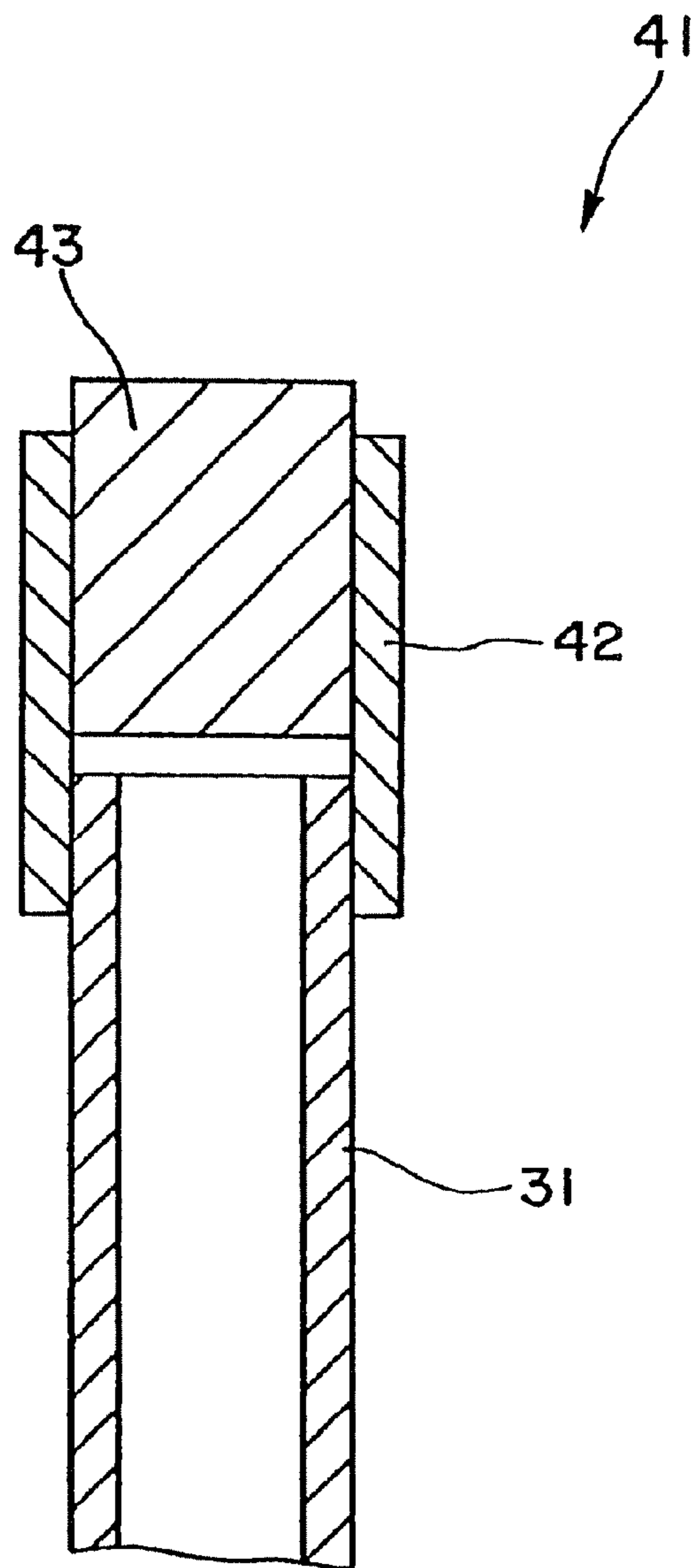

FIG. 7

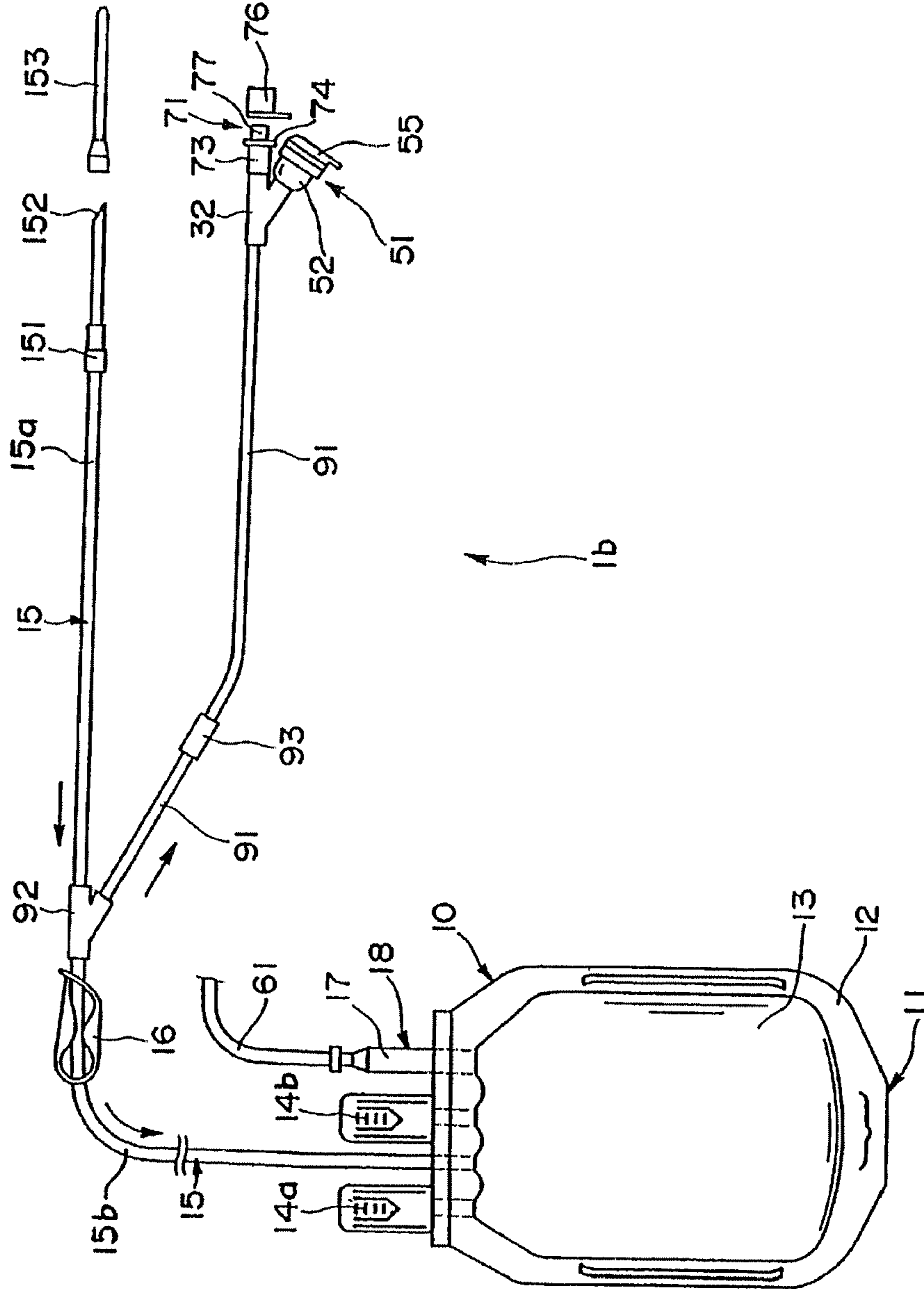

FIG. 8

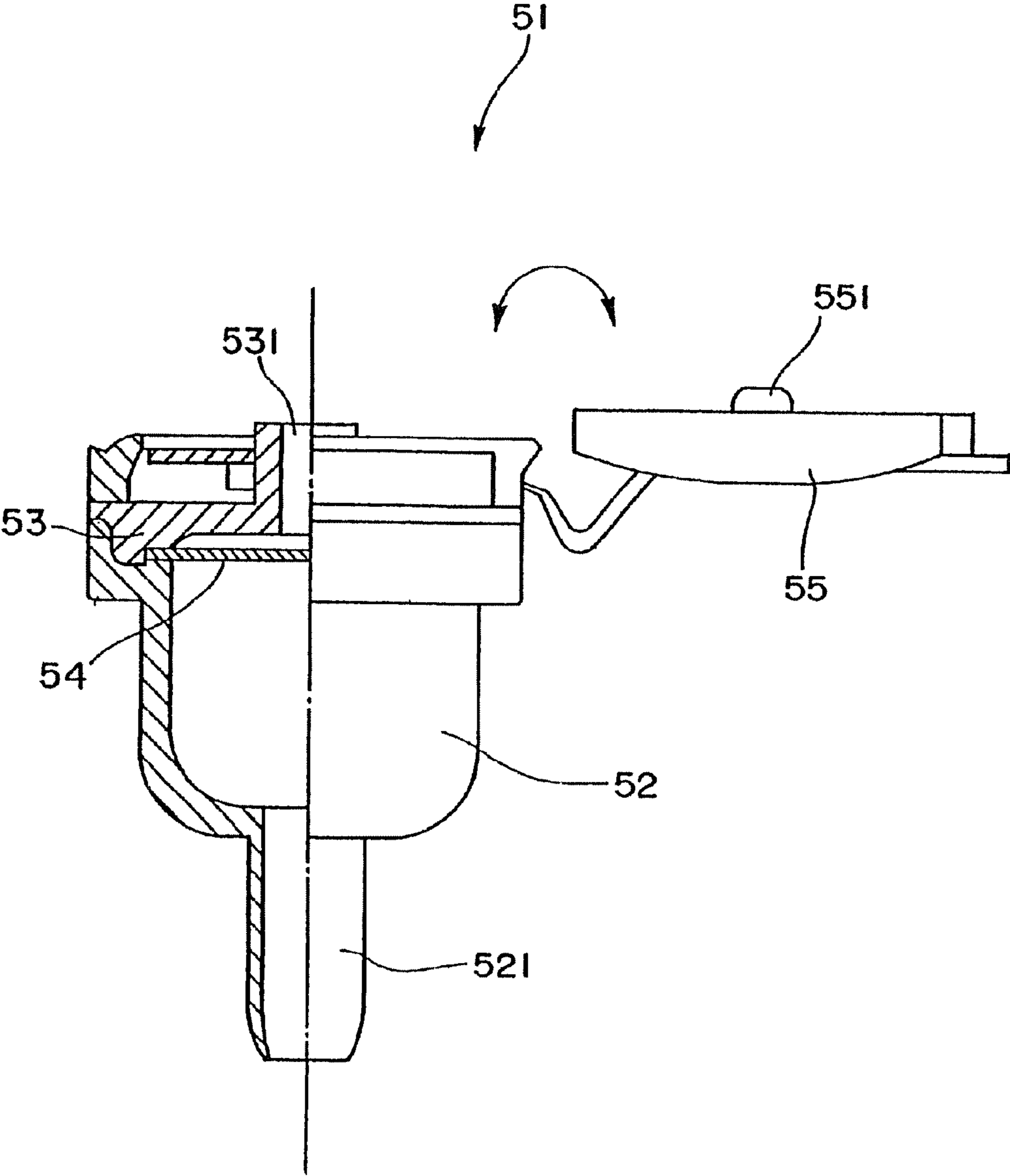

FIG. 9

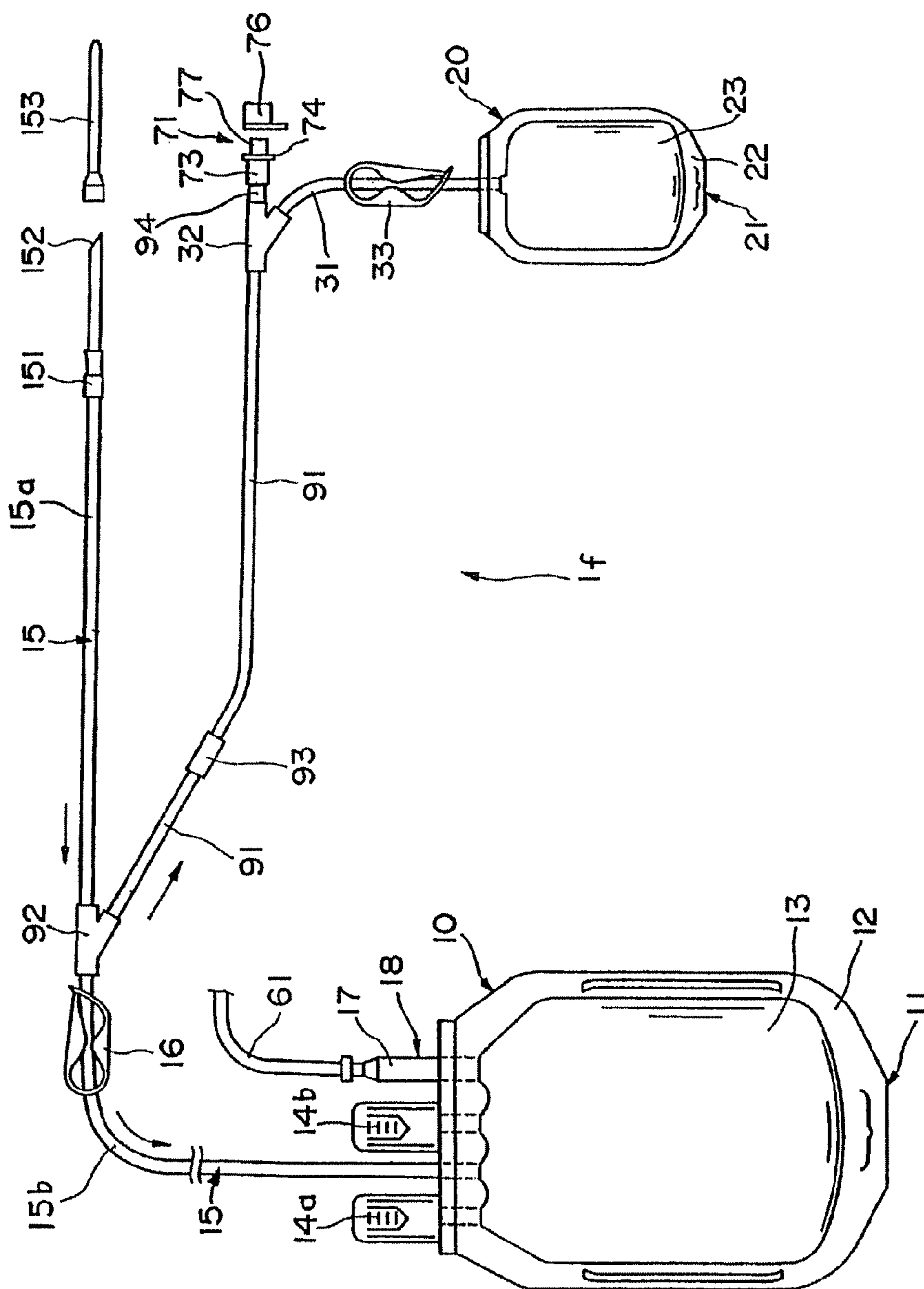

FIG. 10

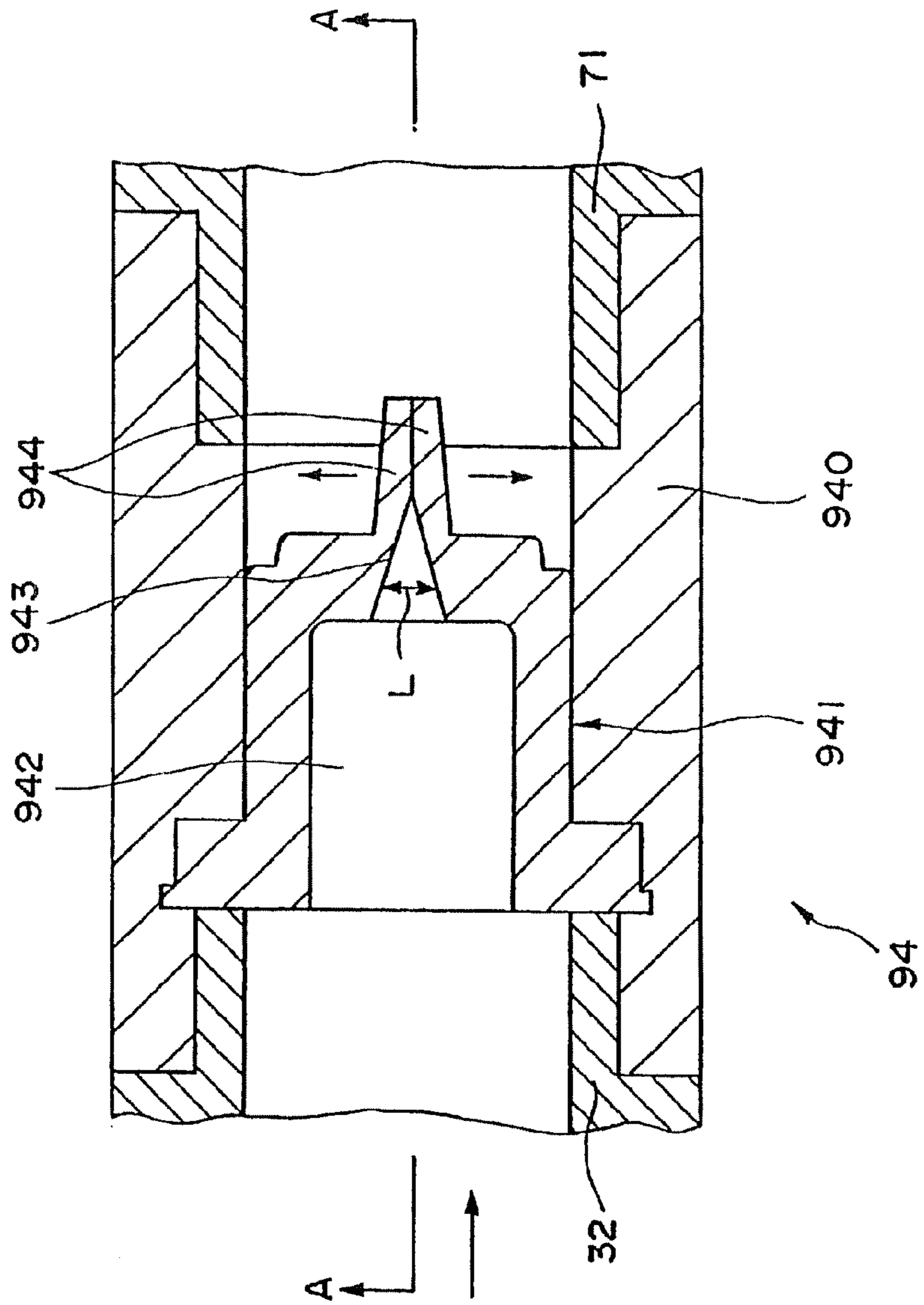

FIG. 11

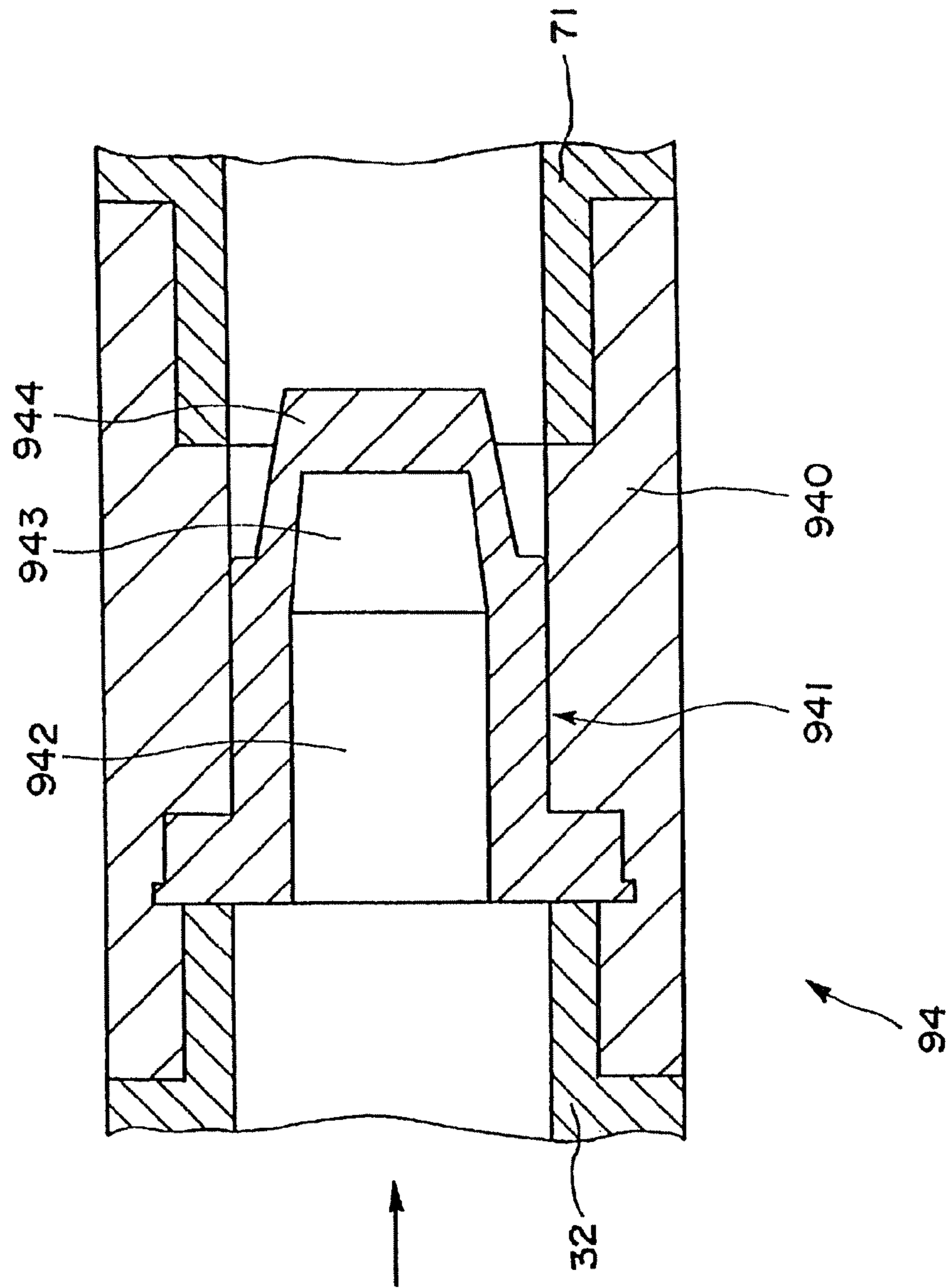

FIG. 12

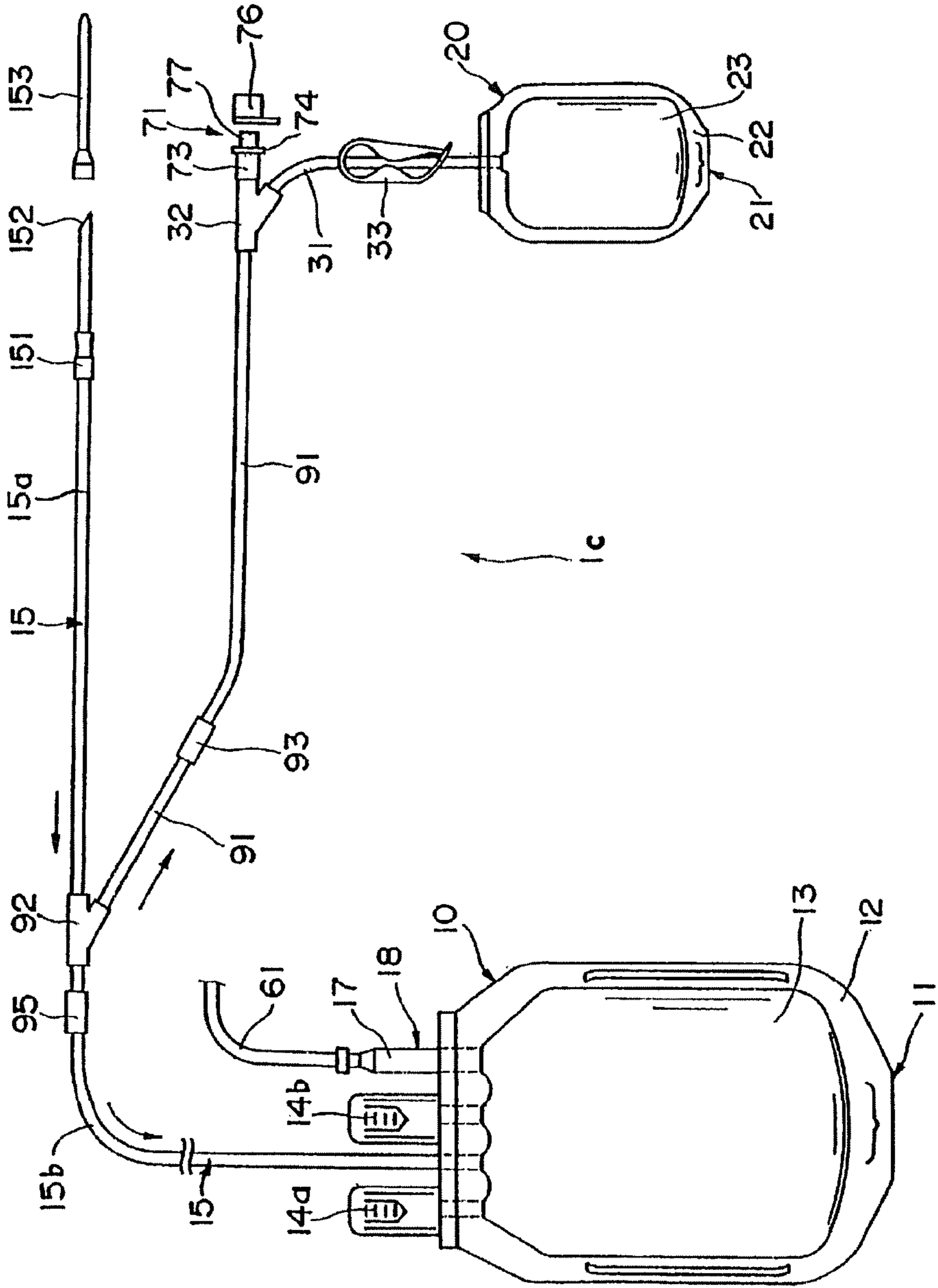

FIG. 13

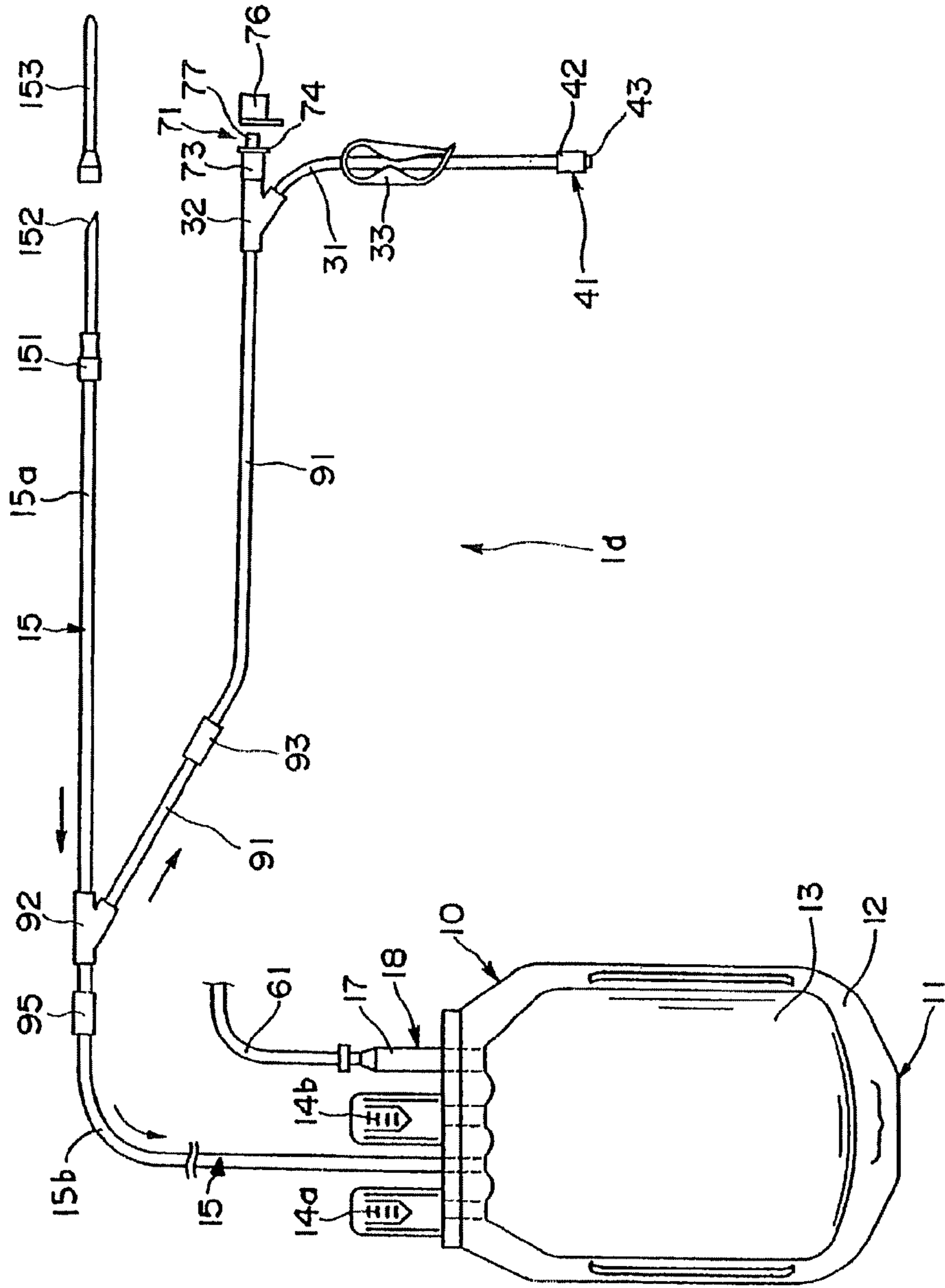
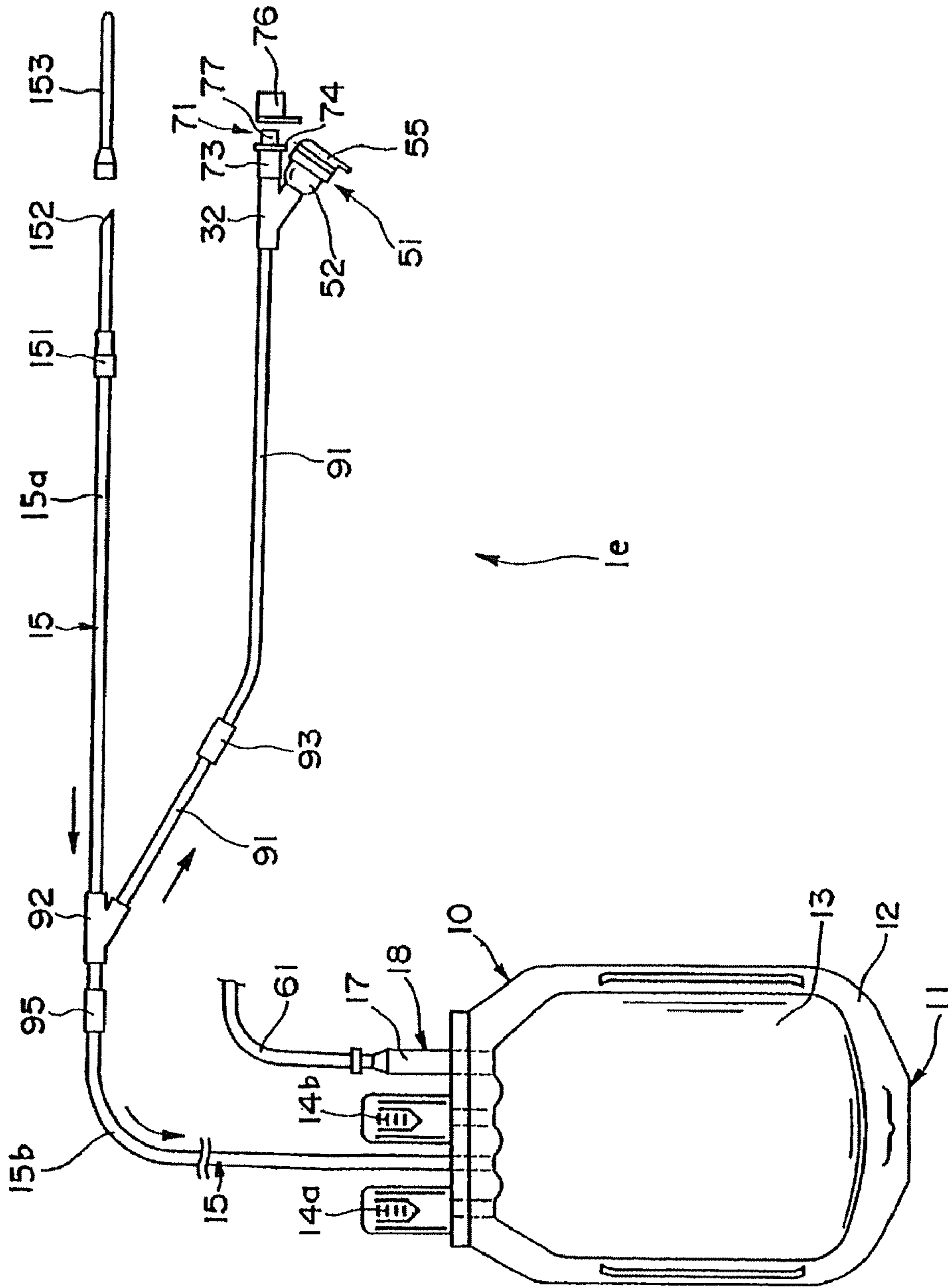

FIG. 14



1

**BLOOD COLLECTING APPARATUS AND
BLOOD COLLECTING METHOD USING
BLOOD COLLECTING APPARATUS**

Matter enclosed in heavy brackets [] appears in the original patent but forms no part of this reissue specification; matter printed in italics indicates the additions made by reissue.

BACKGROUND OF THE INVENTION

The present invention relates to a blood collecting apparatus and a blood-collecting method to be carried out by using the blood collecting apparatus.

In normal blood collecting (operation of introducing blood collected from a donor by a blood collecting needle into a blood collecting bag), a needle-piercing portion of the donor is sterilized with alcohol. But there is a possibility that bacteria present on or under the skin enters the blood collecting bag together with the blood.

The some kind of bacteria which have entered the blood collecting bag increase while the blood collecting bag is kept cold. When the blood is transfused into a patient, the patient may suffer from infectious disease or blood poisoning.

The pH of red blood cell conservation liquid (S.A.G.M. liquid, OPTISOL liquid, M.A.P. liquid, and the like) currently used is substantially neutral, unlike the conventional blood conservation liquid (anticoagulants such as ACD-A liquid and CPD liquid). Thus, in the red blood cell conservation liquid, bacteria increase in a high extent while the blood collecting bag is refrigerated.

Because the bacteria are present not only on the skin but also under the skin, only careful sterilization of the needle-piercing portion is not enough to prevent them from penetrating into blood.

It is experimentally known that bacteria penetrates into an initial flow of collected blood, together with fragments of skin. However, a blood collecting bag or a blood collecting apparatus capable of removing the initial flow of collected blood has not been developed.

It is an object of the present invention to provide a blood collecting apparatus and a blood-collecting method to be carried out by using the blood collecting apparatus capable of preventing blood from being contaminated with bacteria, improving safety, and collecting examination blood in a preferable state.

SUMMARY OF THE INVENTION

In order to achieve the object, there is provided a blood collecting apparatus comprising a blood collecting needle for collecting blood from a donor, a blood collecting bag for accommodating collected blood, a first tube whose one end communicates with said blood collecting bag and other end communicates with said blood collecting needle, a branch portion provided on a portion of said first tube, a second tube connected with said branch portion at one end thereof and having a blood take-out port, and a flexible resin bag and having a third tube communicating with said second tube.

In order to further achieve the object, there is provided a blood collecting apparatus comprising a blood collecting needle for collecting blood from a donor, a blood collecting bag for accommodating collected blood, a first tube whose one end communicates with said blood collecting bag and other end communicates with said blood collecting needle, a branch portion provided on a portion of said first tube, a

2

second tube connected with said branch portion at one end thereof and having a blood take-out port, and a filter gas-permeable and blood-unpermeable and communicable with an interior of said second tube.

In order to further achieve the object, there is provided a blood collecting apparatus comprising, a blood collecting needle for collecting blood from a donor, a blood collecting bag for accommodating collected blood, a first duct whose one end communicates with said blood collecting bag and other end communicates with said blood collecting needle, and introducing said collected blood into said blood collecting bag, a second duct branching from said first duct through a branch portion and having a blood take-out port, and a pressure buffering means for suppressing fluctuation of a pressure of said second duct.

In order to further achieve the object, there is provided a blood collecting method to be carried out by using a blood collecting apparatus comprising: a blood collecting needle for collecting blood from a donor; a blood collecting bag for accommodating collected blood; a first tube whose one end communicates with said blood collecting bag and other end communicates with said blood collecting needle; a branch portion provided on a portion of said first tube; a second tube connected with said branch portion at one end thereof and having a blood take-out port at the other end thereof; and a flexible resin bag and having a third tube communicating with said second tube, said blood collecting method comprising the steps of piercing a blood collecting needle into a donor when a portion of said first tube positioned between said branch portion and said blood collecting bag is sealed, removing air inside said first and second tubes by introducing an initial flow blood from said donor into a portion of said first tube between said blood collecting needle and said branch portion and into said second tube and by accommodating air inside said portion of the first tube positioned between said blood collecting needle and said branch portion and air inside said second tube in said flexible resin bag; and collecting a predetermined amount of blood from said donor in said blood collecting bag by intercepting communication between said first tube and said flexible resin bag and by communicating said portion of said first tube between said blood collecting needle and said branch portion with a portion of said first tube between said branch portion and said blood collecting bag.

In order to further achieve the object, there is provided a blood collecting method to be carried out by using a blood collecting apparatus comprising a blood collecting needle for collecting blood from a donor; a blood collecting bag for accommodating collected blood; a first tube whose one end communicates with said blood collecting bag and other end communicates with said blood collecting needle; a branch portion provided on a portion of said first tube; a second tube connected with said branch portion at one end thereof and having a blood take-out port at the other end thereof; and a filter gas-permeable and blood unpermeable and communicable with an interior of said second tube, said blood collecting method comprising the steps of piercing a blood collecting needle into a donor when a portion of said first tube positioned between said branch portion and said blood collecting bag is sealed, exhausting air inside said first and second tubes from said filter by introducing an initial flow blood from said donor into a portion of said first tube between said blood collecting needle and said branch portion and into said second tube, collecting a predetermined amount of blood from said donor in said blood collecting bag by intercepting communication between said first tube and said filter and by communicating said portion of said first tube between said

3

blood collecting needle and said branch portion with a portion of said first tube between said branch portion and said blood collecting bag.

BRIEF DESCRIPTION OF THE DRAWINGS

FIG. 1 is a plan view showing a first embodiment of the blood collecting apparatus of the present invention.

FIG. 2 is a vertical sectional view showing an example of the construction of a sealing member to be used for the blood collecting apparatus of the present invention.

FIG. 3 is a vertical sectional view showing an example of the construction of a sampling port to be used for the blood collecting apparatus of the present invention.

FIG. 4 is a vertical sectional view showing a front end of the sampling port of FIG. 3, a vacuum blood collecting tube and a holder for the blood collecting tube.

FIG. 5 is a plan view showing a second embodiment of the blood collecting apparatus of the present invention.

FIG. 6 is a sectional view showing an example of a filter for use in the blood collecting apparatus of the present invention.

FIG. 7 is a plan view showing a third embodiment of the blood collecting apparatus of the present invention.

FIG. 8 is a sectional view showing an example of a filter for use in the blood collecting apparatus of the present invention.

FIG. 9 is a plan view showing a fourth embodiment of the blood collecting apparatus of the present invention.

FIG. 10 is a vertical sectional view showing an example of a check valve for use in the blood collecting apparatus of the present invention.

FIG. 11 is a sectional view taken along a line A-A of FIG. 10.

FIG. 12 is a plan view showing the fifth embodiment of the blood collecting apparatus of the present invention.

FIG. 13 is a plan view showing a sixth embodiment of the blood collecting apparatus of the present invention.

FIG. 14 is a plan view showing a seventh embodiment of the blood collecting apparatus of the present invention.

DETAILED DESCRIPTION OF THE PREFERRED EMBODIMENTS

The preferred embodiments of the blood collecting apparatus of the present invention will be described in detail below.

Each of the blood collecting apparatus 1, 1a, 1b, 1c, 1d, 1e, and 1f of the present invention comprises a blood collecting needle 152 for collecting blood from a donor; a blood collecting bag 10 for accommodating collected blood; a first duct whose one end communicates with a blood collecting bag 10 and other end communicates with a blood collecting needle 152 and introducing collected blood into the blood collecting bag 10; a second duct branching from the first duct through a branching portion and having a take-out port of blood at an end thereof. Each of the blood collecting apparatus 1, 1a, 1b, 1c, 1d, 1e, and 1f comprises a pressure buffering means for suppressing the fluctuation of the pressure of the second duct.

More specifically, each of the blood collecting apparatus 1, 1c and 1f of the present invention comprises the blood collecting needle 152 for collecting blood from a donor; the blood collecting bag 10 for accommodating collected blood; a first tube 15 (15a, 15b) whose one end communicates with the blood collecting bag 10 and other end communicates with the blood collecting needle 152; the branch portion 92 provided on a portion of the first tube 15; a second tube 91 connected with the branch portion 92 at one end thereof and having a blood take-out port (sampling port) 71 at the other

4

end thereof; and a flexible resin bag 20 and having a third tube 31 communicating with the second tube 91. The flexible resin bag 20 including the third tube 31 is capable of accommodating air inside a part of the first tube 15 (first tube 15a at the side of the blood collecting needle 152) between the branch portion 92 and the blood collecting needle 152 and air inside the second tube 91 when the blood collecting apparatus is used.

FIG. 1 is a plan view showing a first embodiment of the blood collecting apparatus of the present invention. As shown in FIG. 1, the blood collecting apparatus 1 has a blood collecting bag 10 for accommodating collected blood.

The blood collecting bag 10 has a body 11 formed by fusing (heat fusion, high frequency fusion or the like) or bonding to each other the periphery of a sealing portion 12 of two sheet materials made of a flexible soft resin such as polyvinyl chloride and laminated on each other, as will be described later.

A blood-accommodating portion 13 accommodating collected blood is formed at an inner portion surrounded with the sealing portion 12 of the body 11. The blood collecting bag 10 may be used as a red blood cell bag for preserving red blood cells. In this case, the blood-accommodating portion 13 accommodates and stores red blood cell rich liquid.

Two openings 14a and 14b each sealed with a peel tab are formed at an upper portion of the body 11 such that they can be opened. An outlet port 18 is formed alongside of the opening 14b. The outlet port 18 is connected with one end of a tube 61 through a sealing member 17 (connection member). As the sealing member 17, it is possible to use a member having a construction similar to that of a sealing member 93 that will be described later.

Although not shown in FIG. 1, one or more bags such as a blood plasma bag, a buffy coat bag, a platelet bag (medical fluid-storing bag) may be provided at the other end of the tube 61. That is, the blood collecting apparatus 1 may constitute a bag-connected device.

In the present invention, it is possible to omit the provision of the sealing member 17, the outlet port 18, and the tube 61.

One end of the flexible first tube 15 communicating with the blood-accommodating portion 13 is connected with the body 11 at an upper portion thereof. A blood collecting needle 152 is installed at the other end of the first tube 15 through a hub 151. A cap 153 which is to cover the blood collecting needle 152 is installed on the hub 151. A main part of the first duct is composed of the lumen of the first tube 15.

The first branch connector 92 (branch portion) branching bifurcately is provided at a portion of the first tube 15. For example, the first branch connector 92 (branch portion) is located at an intermediate portion of the first tube 15 or at the side of the blood collecting bag 10 of the first tube 15. One end of the flexible second tube 91 is connected with the first branch connector 92. A main part of the second duct is composed of the lumen of the second tube 91. The first tube 15 comprises a first tube 15a which is positioned at the side of the blood collecting needle 152 with respect to the first branch connector 92 and a first tube 15b which is positioned at the side of the blood collecting bag 10 with respect to the first branch connector 92.

Although the first branch connector 92 shown in FIG. 1 consists of a y-shaped tube, the first branch connector 92 of the present invention may be Y-shaped, T-shaped or inverse y-shaped.

A clamp (first duct-sealing member) 16 is provided on a portion of the first tube 15 between the first branch connector 92 and the blood collecting bag 10. That is, the clamp 16 is provided on the first tube 15b located at the side of the blood

collecting bag **10** with respect to the first branch connector **92**. Preferably, the clamp **16** is positioned proximately to the first branch connector **92**.

A second branch connector (branch portion) **32** branching bifurcately is provided at the other end of the second tube **91**. The second branch connector **32** is connected with a sampling port (connector) **71** constituting a blood take-out port. The construction of the sampling port **71** will be described in detail later.

Although the second branch connector **32** shown in FIG. **1** consists of a y-shaped tube, the second branch connector **32** of the present invention may be Y-shaped, T-shaped or inverse y-shaped.

In the blood collecting apparatus **1**, the sampling port **71** is connected with the other end of the second tube **91** through the second branch connector **32**. It is possible to position the second branch connector **32** at a portion of the second tube **91** between both ends thereof and directly connect the sampling port **71** with the other end of the second tube **91**. The sampling port (blood take-out port) **71** may be provided at a portion of the second tube **91**. For example, the sampling port (blood take-out port) **71** may be provided at an intermediate portion of the second tube **91** or at the other end side of the second tube **91**.

A sealing member (second duct-sealing member) **93** is provided at a portion of the second tube **91**. In this case, preferably, the sealing member **93** is positioned proximately to the first branch connector **92**. The construction of the sealing member **93** will be described in detail later.

The blood collecting apparatus **1** has a flexible resin bag **20** for suppressing fluctuation of pressure.

The flexible resin bag **20** has a body **21** formed by fusing (heat fusion, high frequency fusion or the like) or bonding to each other the periphery of a sealing portion **22** of two sheet materials made of a flexible soft resin such as polyvinyl chloride and laminated on each other, as will be described later.

The body **21** has an accommodating portion **23** formed in an inner part thereof surrounded with a sealing portion **22** thereof.

One end (termination) of a flexible third tube **31** communicating with the accommodating portion **23** is connected with the body **21** at an upper portion thereof. The other end of the third tube **31** is connected with the second branch connector **32**. A main part of the third duct is composed of the lumen of the third tube **31**.

The capacity of the bag **20** is not limited to a specified one but determined in consideration of various conditions such as the spatial volume (capacity) of the lumen of the tubes forming the circuit. It is favorable to set the capacity of the bag **20** to 1-100 ml and more favorable to 5-30 ml. If the capacity of the bag **20** is less than the lower limit of the above-described range, the effect of the bag **20** which will be described later may not be obtained when the spatial volume of the lumen of the tube forming the circuit is comparatively large. On the other hand, if the capacity of the bag **20** is more than the upper limit of the above-described range, the blood collecting apparatus **1** is caused to be large.

The flexible resin bag **20** including the third tube **31** is capable of accommodating air inside the first tube **15a** at the side of the blood collecting needle **152** and air inside the second tube **91** when the blood collecting apparatus is used.

A clamp (third duct-sealing member) **33** is provided on the third tube **31**. Preferably, the clamp **33** is positioned proximately to the second branch connector **32** to prevent reduction of the amount of an initial flow of collected blood (hereinafter referred to as initial flow blood or initial introduced

blood) which can be introduced into a first vacuum blood collecting tube **85** which will be described later.

In the blood collecting apparatus **1**, a pressure buffering means for preventing fluctuation of the pressure in the second duct is constituted of the second branch connector **32**, the third tube **31**, the clamp **33**, and the bag **20**.

It is preferable to set the area of the sectional surface of the duct of the second tube **91** smaller than that of the sectional surface of the first tube **15**. That is, it is preferable to set the inner diameter of the second tube **91** smaller than that of the first tube **15** to allow collected blood to be left in a small amount in the second tube **91** in introducing collected blood into the blood collecting bag **10**, as will be described later.

It is preferable to put an anticoagulant agent in the blood collecting bag **10** in advance. Normally, the anticoagulant agent is a liquid. An ACD-A liquid, a CPD liquid, and a CPDA-1 liquid, and a heparin sodium liquid can be used as the anticoagulant agent. The amount of the anticoagulant agent is appropriately determined according to an amount of blood to be collected.

The sheet material composing the blood collecting bags **10** and **20** and the material composing the first tube **15**, the third tube **31**, the tube **61**, and the second tube **91** will be described below.

[1] Material of Blood Collecting Bag **10**

The composition, characteristic, and the like of the material of the sheet composing the body **11** of the blood collecting bag **10** are not limited to specified ones.

In this case, as the sheet material composing the blood collecting bag **10**, soft polyvinyl chloride or materials containing the soft polyvinyl chloride as their main component can be preferably used. For example, a copolymer containing the soft polyvinyl chloride as its main component and a small amount of macromolecular material, a polymer blend, a polymer alloy, and the like can be used.

As the plasticizer for the soft polyvinyl chloride, dioctylphthalate (DEHP, di(2-ethylhexyl)phthalate) and (DnDP, di(n-decyl)phthalate) can be preferably used.

It is favorable to contain the plasticizer in the sheet material at 25-50 wt % and more favorable at 30-40 wt %. The above-described sheet materials can be manufactured by a method described below.

Using a kneader, materials are kneaded sufficiently. Then, a kneaded material is extruded through a T-shaped die or a circular die. Then, a resulting flat sheet-shaped material is processed into a desired shape/form by sequentially performing the steps of thermoforming, blowing, drawing, cutting, and sealing (fusing) of the edge thereof.

In order to prevent blocking from occurring between sheets (base material), it is possible to roughen (emboss) the surface of each sheet or add or apply a blocking-preventing agent, a slip agent or the like to the materials.

[2] Material of Flexible Resin Bag **20**

The composition, characteristic, and the like of the sheet material composing the body **21** of the bag **20** are not limited to specified ones. For example, materials similar to the sheet material of the blood collecting bag **10** may be used to form the bag **20**. In this case, the kind of sheet material to be prepared can be reduced, which is advantageous in manufacturing the bag **20**.

[3] Materials of Tubes **15**, **31**, **61**, and **91**

As the material of the tubes **15**, **31**, **61**, and **91**, thermoplastic elastomers or thermoplastic flexible resin such as soft polyvinyl chloride, polyethylene, polypropylene, ethylene-vinyl acetate copolymer, styrene-butadiene-styrene copolymer, and materials containing the thermoplastic elastomers or the thermoplastic flexible resin. The soft polyvinyl chloride

and a material containing the soft polyvinyl chloride as its main component are preferable.

The tubes **15**, **31**, **61**, and **91** made of the soft polyvinyl chloride can be handled easily because they are flexible and pliable and can be suitably sealed with a clamp or the like. Further, because the soft polyvinyl chloride is compatible with the sheet material of the bags **10** and **20**, the tube made of the soft polyvinyl chloride and the sheet material of the bags **10** and **20** can be fused or bonded to each other at a high degree. Furthermore, the tube made of the soft polyvinyl chloride has a high degree of airtightness. In addition, the tube made of the soft polyvinyl chloride is durable for centrifuging operation and preferably maintains sterility. The kind of plasticizer to be used for the tubes is not specified. The content thereof is also not specified.

The sizes such as the inner and outer diameters of the second tube **91** are not specified. But if the inner diameter thereof is too large or the thickness thereof is too small (ratio of outer diameter to inner diameter is small), the second tube **91** is likely to be flatly deformed when high pressure-steam sterility is performed. This is because the second tube **91** is soft and sealed with the sealing member **93** and a cap **76** which will be described later.

If the inner diameter of the second tube **91** is comparatively large, the spatial volume (volume) of the lumen of the second tube **91** is large accordingly. Consequently, blood loss may occur because of the large spatial volume when collecting of an initial flow blood or an initial introduced blood (hereinafter referred to as initial blood collection) and subsequent (main) blood collection are performed.

As a measure to solve the problem of the volume inside the second tube **91**, it is conceivable to adopt a method of using the second tube **91** having small inner and outer diameters. But there is a limitation in the reduction of the outer diameter of the second tube **91** because it is necessary to connect (join) the second tube **91** with other members. Further, the method is incapable of preventing deformation of the second tube **91** sufficiently in the high pressure-steam sterilization.

Accordingly, to solve such a problem effectively, it is favorable to set the inner diameter of the second tube **91** to 0.5-2.0 mm and more favorable to 0.8-1.5 mm. it is also favorable to set the outer diameter thereof to 2-4 times as large as the inner diameter thereof and more favorable to 2.5-3.5 times as large as the inner diameter thereof.

If the inner diameter of the second tube **91** exceeds the upper limit of the above-described range, the amount of air to be exhausted from the second tube **91** increases in the initial blood collecting into the vacuum blood collecting tube **85** which will be described later. Thus, it is necessary to shorten the second tube **91** or increase the volume of the bag **20**.

If the inner diameter of the second tube **91** is less than the lower limit of the above-described range, blood is prevented from smoothly flowing in the initial blood collecting into the vacuum blood collecting tube **85**. That is, there is a possibility that the flow rate of the blood is insufficient. It is preferable that the flow rate of blood is in the range of 1-5 ml/sec.

The outer diameter of the second tube **91** most suitable in the connection thereof with other members is preferably in the range of 4.0-4.5 mm.

The construction of each of the sealing members **17** and **93** will be described below. The constructions of the sealing members **17** and **93** are similar to each other. Thus, the construction of the sealing member **93** will be described below representatively.

FIG. 2 is a longitudinal sectional view showing an example of the construction of the sealing member, **93**. As shown in FIG. 2, the sealing member **93** comprises a short tube **930**

made of a flexible resin such as soft polyvinyl chloride and a cylindrical body **931** which is liquid-tightly inserted into the short tube **930** and whose one end is sealed with a solid columnar portion **932**.

One end of the second tube **91** positioned at an upper side in FIG. 2 is liquid-tightly connected with the upper end of the short tube **930**. One end of the second tube **91** positioned at a lower side in FIG. 2 is liquid-tightly connected with the lower end of the short tube **930**.

A thin and frail breakable portion **933** is formed on the periphery of the cylindrical body **931**. The breakable portion **933** is broken by bending the solid columnar portion **932** together with the short tube **930** with fingers to separate the solid columnar portion **932** from the cylindrical body **931**. As a result, the duct of the sealing member **93** is opened.

The cylindrical body **931** is made of hard materials such as hard polyvinyl chloride, polycarbonate, polyester or the like.

Referring to FIG. 2, the upper portion of the solid columnar portion **932** is wedge-shaped. The upper end of the solid columnar portion **932** is widthwise smaller than the outer diameter of the cylindrical body **931** and widthwise larger than the inner diameter of the second tube **91**. This is because the solid columnar portion **932** does not seal the second tube **91** after the solid columnar portion **932** is broken and separated from the cylindrical body **931**. As shown in FIG. 2, a groove **935** may be formed on the upper end portion **934** of the solid columnar portion **932** to accelerate the flow of blood.

The construction of the sampling port **71** will be described below. FIG. 3 is a vertical sectional view showing an example of the construction of the sampling port **71**. In the description made below, the right side of the sampling port **71** in FIG. 3 is referred to as "front side" and the left side thereof is referred to as "rear side".

As shown in FIG. 3, the sampling port **71** comprises a body **73**, a plug **77**, and a cap **76**. The rear side **732** of the body **73** is liquid-tightly connected with the second branch connector **32**. The body **73** is substantially cylindrical and has a rib **74** erected from the peripheral surface thereof.

The plug **77** is fitted on a front end **731** of the body **73**. The cap **76** to cover the plug **77** is installed on the body **73** at its front side. A blood take-out port is formed at a front portion of the body **73** such that the blood take-out port is proximate to the plug **77**.

The body **73** and the rib **74** are made of hard a material such as hard polyvinyl chloride, polycarbonate, polyester or the like.

The material composing the plug **77** is selected from materials into which a blood collecting needle can be pierced comparatively easily. For example, rubber materials such as natural rubber, isoprene rubber, butyl rubber, silicone rubber, urethane rubber, acrylic rubber, and butadiene rubber, styrene-butadiene rubber can be preferably used.

As the material composing the cap **76**, rubber materials such as natural rubber, isoprene rubber, butyl rubber, silicone rubber, urethane rubber, acrylic rubber, and butadiene rubber, styrene-butadiene rubber can be preferably used.

As shown in FIG. 4, a holder **82** of the vacuum blood collecting tube (vessel) **85** is connected with the sampling port **71** to allow an initial flow blood or an initial introduced blood (initial flow of collected blood) to be collected by the vacuum blood collecting tube **85** through the holder **82**.

The vacuum blood collecting tube **85** comprises a body **86** and a rubber plug **87** fitted on the body **86**. The interior of the vacuum blood collecting tube **85** is vacuum or in a pressure-reduced state.

The holder **82** comprises a cylindrical body **83** having a bottom and a double ended needle **84** provided coaxially with the body **83**.

In this case, a member (lure adapter **841**) having a male screw formed thereon is fixed to the double-headed needle **84**. A female screw engaging the male screw is formed at the center of the bottom portion of the body **83** (left end of body **83** in FIG. 4). The double-headed needle **84** is removably fixed to the body **83** by engaging the male and female screws each other.

The length of the double-headed needle **84** at its left side in FIG. 4 is so set that it can be pierced sufficiently into the plug **77**. The length thereof at its right side is also so set that it can be pierced sufficiently into the rubber plug **87**.

Although not shown in FIG. 4, it is possible to form an elastic covering member covering the double-headed needle **84** at least one side of the lure adapter **841** to prevent blood from leaking from the double-headed needle **84**.

With reference to FIGS. 1 and 4, the operation of the blood collecting apparatus **1**, namely, the blood collecting method that is carried out by using the blood collecting apparatus **1** will be described below.

The blood collecting method is carried out by using a blood collecting apparatus **1** comprising a blood collecting needle **152**; a blood collecting bag **10** for accommodating collected blood; a first tube **15** whose one end communicates with the blood collecting bag **10** and other end communicates with the blood collecting needle **152**; a branch portion **92** provided on a portion of the first tube **15**; a second tube **91** connected with the branch portion **92** at one end thereof and having a blood take-out port **71**; and a flexible resin bag **20** having a third tube **31** communicating with the second tube.

The blood collecting method comprises the step of piercing a blood collecting needle into a donor when a portion of the first tube positioned between the branch portion and the blood collecting bag is sealed; the step of removing air inside the first and second tubes by introducing an initial flow blood (initial introduced blood) from the donor into a portion of the first tube between the blood collecting needle and the branch portion and into the second tube and by accommodating air inside the portion of the first tube positioned between the blood collecting needle and the branch portion and air inside the second tube in the flexible resin bag; the step of sampling a predetermined amount of blood from the initial flow blood by using the blood take-out port; and the step of collecting a predetermined amount of blood by intercepting communication between the first tube and the flexible resin bag and by communicating the portion of the first tube between the blood collecting needle and the branch portion with a portion of the first tube between the branch portion and the blood collecting bag.

Initially, the step of piercing the blood collecting needle **152** into a donor is performed in the condition that a portion of the first tube (first tube **15b** at the side of blood collecting bag **10**) positioned between the branch portion (first branch connector **92**) and the blood collecting bag **10** is sealed and the first tube **15a** is communicated to the flexible resin bag **20**.

More specifically, as shown in FIG. 1, the first tube **15** (first tube **15b** at the side of blood collecting bag **10**) is sealed with the clamp **16** to close (intercept) the duct thereof. The clamp **33** is opened to open the duct of the third tube **31**.

Then, the blood collecting needle **152** is pierced into the vein (blood vessel) of the donor. When it is confirmed that the blood collecting needle **152** is in the vein, the hub **151** is fixed with a tape. Then, to open the duct of the sealing member **93**,

the breakable portion **933** of the sealing member **93** is broken to separate the solid columnar body **932** from the cylindrical body **931**.

After completing the needle-piercing step, the step of removing air from the tubes is performed. That is, an initial flow blood from the donor is introduced into the portion of the first tube (first tube **15a** at the side of the blood collecting needle **152**) between the blood collecting needle **152** and the branch portion (the first branch connector **92**) and into the second tube **91** to accommodate the air inside the portion of the first tube (first tube **15a** at the side of the blood collecting needle **152**) positioned between the blood collecting needle **152** and the branch portion **92** and the air inside the second tube **91** in the flexible resin bag **20**.

More specifically, by carrying out the needle-piercing step, the initial flow of the collected blood is introduced into the second tube **91** through the blood collecting needle **152**, a part of the first tube **15** (the first tube **15a** at the side of the blood collecting needle **152**) and the first branch connector **92**, thus flowing toward the sampling port **71**. In this case, the duct of the first tube **15** is intercepted with the clamp **16**. Thus, the blood flows from the first tube **15** (the first tube **15a** at the side of the blood collecting needle **152**) to the second tube **91** through the first branch connector **92**. The blood is introduced into the second tube **91** by utilizing the pressure of the vein and locating the sampling port **71** and the bag **20** below the position at which the blood collecting needle **152** is pierced into the donor.

In introducing the collected blood into the second tube **91**, the air inside a part of the first tube **15** (the first tube **15a** at the side of the blood collecting needle **152**), the air inside the second tube **91**, and the air inside the first branch connector **92** flow into the third tube **31** through the second branch connector **32**, thus being exhausted from one end of the third tube **31** and collected by the bag **20**. In other words, decrease of the volume of the lumen of a part of the first tube **15** (first tube **15a** at the side of the blood collecting needle **152**) and the second tube **91** caused by the introduction of the blood thereinto, namely, increase in the pressure of the lumen of the first tube **15** and the second tube **91** can be suppressed (restrained) by the expansion of the bag **20**. That is, because the pressure inside the first tube **15** and the second tube **91** can be kept substantially constant, it is possible to prevent an excess load from being applied to blood cells. Thus, it is possible to prevent the blood from hemolyzing. Further, it never happens that the blood flows into the first branch connector **92** at the side of the clamp **16**.

After the step of removing the air from the tubes is performed, the step of sampling blood from the initial flow blood is performed. That is, the step of sampling a predetermined amount of blood from the blood take-out port (sampling port **71**) is performed. In the step of sampling blood, it may be sampled a part of the initial flow blood or blood including all of the initial flow blood.

More specifically, when the blood has reached proximately to the second branch connector **32**, the third tube **31** is sealed with the clamp **33** to close (intercept) the duct thereof thereby to stop the introduction of the blood.

Then, as shown in FIGS. 3 and 4, the cap **76** is removed from the body **73** of the sampling port **71**. Then, the double-headed needle **84** of the holder **82** is pierced into the plug **77** of the sampling port **71** and penetrated therethrough to install the holder **82** on the sampling port **71**.

Then, to sample or collect blood from the initial flow blood, the vacuum blood collecting tube **85** is inserted into the innermost portion of the holder **82** and pressed thereinto, and the double-headed needle **84** of the holder **82** is pierced through

the rubber plug **87**. As a result, the blood is sucked into the vacuum blood collecting tube **85** and collected thereby. In this case, the interior of the first tube **15** (the first tube **15a** at the side of the blood collecting needle **152**) and that of the second tube **91** both positioned between the blood collecting needle **152** and the sampling port **71** are mostly filled with the blood. Thus, when the double-headed needle **84** of the holder **82** is pierced through the rubber plug **87** of the vacuum blood collecting tube **85** to suck the blood into the vacuum blood collecting tube **85**, an excess load can be prevented from being applied to blood cells. Thus, it is possible to prevent the blood from hemolyzing, and further, it never happens that the blood flows into the first branch connector **92** at the side of the clamp **16**.

When the sampling of the initial flow blood into the first vacuum blood collecting tube **85** is completed, the vacuum blood collecting tube **85** is extracted from the holder **82**. Then, as necessary, the next vacuum blood collecting tube **85** is inserted through the holder **82** and pressed into the innermost portion of the holder **82**. Then, the double-headed needle **84** of the holder **82** is pierced into the rubber plug **87** and penetrated therethrough. As a result, the blood is sucked into the vacuum blood collecting tube **85** and collected thereby. This operation is repeated to collect the initial flow blood into a necessary number of the vacuum blood collecting tubes **85**.

After the blood collecting into the vacuum blood collecting tube **85**, i.e., after the collecting of the initial flow blood into the vacuum blood collecting tubes **85** terminates, the holder **82** is removed from the sampling port **71**, and then, the cap **76** is installed on the body **73** of the sampling port **71**.

Because the plug **77** is fitted on the body **73** of the sampling port **71**, the plug **77** prevents leak of the blood.

After the step of sampling blood from the initial flow blood terminates, the communication between the first tube **15** and the flexible resin bag **10** is intercepted, the main blood collecting step is performed. That is, a predetermined amount of blood is collected by communicating the first tube **15a** with the portion of the first tube (the first tube **15b** at the side of the blood collecting bag **10**) positioned between the first branch portion **92** and the blood collecting bag **10**.

More specifically, the step of collecting the blood into the blood collecting bag **10** is started. The blood collection is performed by using a blood collecting device of decompression type or by locating the blood collecting bag **10** at a position below the position at which the blood collecting needle **152** is pierced into the donor, namely, by utilizing the difference between the levels of the two positions.

In this case, the clamp **16** is opened to open the duct of the first tube **15**. Consequently, the blood of the donor flows through the first tube **15**, thus being introduced into the blood-accommodating portion **13** of the blood collecting bag **10**.

After a predetermined amount of blood is collected, the blood collecting needle **152** is removed from the blood vessel of the donor. Then, the cap **153** is installed on the hub **151**. If necessary, the second tube **91** and the first tube **15** are fused, respectively with tube sealer or the like. Then, sealed portions of the first and second tubes **15** and **91** are cut off to remove the portion thereof located at the side of the sampling port **71**. In this manner, it is possible to obtain the blood collecting bag **10** accommodating the blood not containing the initial flow blood.

in the case of the above-described bag-connected device, the blood accommodated in the blood collecting bag **10** is centrifuged to separate it into a plurality of blood components such as red blood cells, buffy coat, and blood plasma. Then, the obtained blood components are delivered to a predeter-

mined blood component bag connected with the blood collecting bag **10**, according to the normal procedure.

The initial flow blood collected in the vacuum blood collecting tube **85** is discarded or can be used for biochemical examinations of blood serum and examinations of the antibody for virus (for example, AIDS, hepatitis and the like) of infectious disease.

As described above, according to the blood collecting apparatus **1**, it is possible to collect not containing an initial part of the initial flow blood having a probability of microbism easily and reliably. Thus, the blood collecting apparatus **1** prevents inclusion of bacteria into collected blood or respective components separated from the collected blood, thus having a high degree of safety.

If the blood collecting apparatus **1** does not have the second branch connector **32**, the third tube **31**, the clamp **33**, and the bag **20**, there is a possibility that some of the initial flow blood flows into the first branch connector **92** at the side of the clamp **16** and is left therein. In this case, the blood remaining there may enter into the vacuum blood collecting tube **85** when the main blood collecting is carried out.

The main reason for the penetration of the blood into the first branch connector **92** at the side of the clamp **16** is as follows: Let it be supposed that the blood collecting apparatus **1** does not have the bag **20**. In this case, in the collecting of the initial flow blood into the vacuum blood collecting tube **85** by introducing it into the second tube **91**, the air inside the first tube **15a** and the second tube **91** has nowhere to escape and thus cannot be exhausted to the outside. Thus, the interior of the portion or the first tube **15** and the second tube **91** located between the blood collecting needle **152** and the sampling port **71** cannot be filled with the blood, which causes the interface between the air and the blood is stopped at a portion of the first tube **15** or the second tube **91**. When the vacuum blood collecting tube **85** is installed on the holder **82** in this state, the air inside the first tube **15** and the second tube **91** is sucked into the vacuum blood collecting tube **85** immediately after the vacuum blood collecting tube **85** and the sampling port **71** communicate with each other. As a result, the duct of the first tube **15** and that of the second tube **91** become decompressed rapidly. To restore the decompressed state inside the circuit to a normal pressure, the inside of the circuit is filled with the blood. At this time, the blood also flows into the first branch connector **92** at the side of the clamp **16**.

Because the blood collecting apparatus **1** has the second branch connector **32**, the third tube **31**, the clamp **33**, and the bag **20**, the blood is prevented from being introduced into the first branch connector **92** at the side of the clamp **16**, as described above. Thus, it is possible to eliminate the initial flow blood reliably.

If the blood collecting apparatus **1** does not have the second branch connector **32**, the third tube **31**, the clamp **33**, and the bag **20**, the blood introduced into the vacuum blood collecting tube **85** may be hemolyzed. The hemolysis may cause sodium and potassium contained in blood serum to be measured at a low accuracy.

The cause of the occurrence of the hemolysis is as follows: As described above, let it be supposed that the blood collecting apparatus **1** does not have the bag **20**. In this case, in the collecting of the initial flow blood into the vacuum blood collecting tube **85** by introducing it into the second tube **91**, the interior of the portion of the first tube **15** and the second tube **91** located between the blood collecting needle **152** and the sampling port **71** cannot be filled with the blood. When the vacuum blood-collecting tube **85** is installed on the holder **82** in this state, the air inside the first tube **15** and the air inside the second tube **91** are sucked into the vacuum blood collecting

13

tube **85** immediately after the vacuum blood collecting tube **85** and the sampling port **71** communicate with each other. As a result, the duct of the first tube **15** and that of the second tube **91** become decompressed rapidly. At this time, the first tube **15** and the second tube **91** are crushed, depending on the position of the blood collecting needle **152**, the degree of softness of blood vessel, and the like. As a result, the sectional area of the duct of the first tube **15** and that of the second tube **91** are reduced and negative pressure is comparatively large (sucking-caused moving speed of blood is comparatively large). Consequently, cells and in particular red blood cells of the collected initial flow blood are damaged.

Because the blood collecting apparatus **1** has the second branch connector **32**, the third tube **31**, the clamp **33**, and the bag **20**, the blood is prevented from being hemolyzed, as described above.

It is normal to collect the initial flow blood by sequentially providing the holder **82** with a plurality of the vacuum blood collecting tubes **85**. If the blood collecting apparatus **1** does not have the second branch connector **32**, the third tube **31**, the clamp **33**, and the bag **20**, the first vacuum blood collecting tubes **85** has a smaller amount of the initial flow blood than a predetermined collectible amount (maximum amount of initial flow blood to be collected by sucking in decompressed state). The shortage of the amount of the initial flow blood affects the number of items to be examined, examination accuracy, and workability in examination adversely.

The main reason for the shortage of the amount of the initial flow blood is as follows: Let it be supposed that the blood collecting apparatus **1** does not have the bag **20**. In this case, in the collecting of the initial flow blood into the vacuum blood collecting tube **85** by introducing it into the second tube **91**, the air inside the first tube **15a** and the second tube **91** cannot be exhausted to the outside. Thus, the interior of the portion of the first tube **15** and the second tube **91** located between the blood collecting needle **152** and the sampling port **71** cannot be filled with the blood. When the vacuum blood collecting tube **85** is installed on the holder **82** in this state, the air inside the first tube **15** and the air inside the second tube **91** are sucked into the vacuum blood collecting tube **95** and collected thereby.

The blood collecting apparatus **1** has the second branch connector **32**, the third tube **31**, the clamp **33**, and the bag **20**. Thus, as described previously, the initial flow blood can be introduced into the first vacuum blood collecting tube **85**, with the interior of the portion of the first tube and the second tube **91** located between the blood collecting needle **152** and the sampling port **71** being filled with blood. Further, when the vacuum blood collecting tube **85** is installed on the holder **82**, the third tube **31** is sealed with the clamp **33** to intercept the duct thereof. Therefore, it is possible to prevent the air inside the bag **20** and the air inside the portion of the third tube **31** located between the clamp **55** and the bag **20** from being introduced into the vacuum blood collecting tube **85** and thus allow the amount of the initial flow blood which is introduced into the first vacuum blood collecting tubes **85** to be substantially equal to that the predetermined collectable blood amount.

Further, because the blood collecting apparatus **1** has the sealing member **93** provided on the second tube **91**, it is possible to select the time at which a collected initial flow blood starts to flow toward the second tube **91**. Thus, according to an instrument to be connected with, installed on or inserted into the sampling port **71**, the collected initial flow blood can be flowed through the second tube **91** at an appropriate timing.

14

Further, the blood collecting apparatus **1** has the sealing member **93** serving as the second duct-sealing member. The sealing member **93** has a higher degree of operability than a clamp and a forceps.

Further, the blood collecting apparatus **1** has the clamp **16** serving as the first duct-sealing member. The clamp **16** has a higher degree of operability than other sealing members.

As described previously, the inner diameter of the second tube **91** is set comparatively small (0.5-2.0 mm), and the thickness thereof is set comparatively large (the outer diameter thereof to 2-4 times as large as the inner diameter thereof) to prevent the second tube **91** from being deformed (crushed) at the time of high pressure-steam sterility.

The second embodiment of the blood collecting apparatus of the present invention will be described below.

The blood collecting apparatus **1a** of the second embodiment comprises a blood collecting needle **152** for collecting blood from a donor; a blood collecting bag **10** for accommodating collected blood; a first tube **15** (**15a**, **15b**) whose one end communicates with the blood collecting bag **10** and other end communicates with the blood collecting needle **152**; a branch portion **92** provided on a portion of the first tube **15**; a second tube **91** connected with the branch portion **92** at one end thereof and having a blood take-out port at the other end thereof; and a filter **41** gas-permeable and blood-unpermeable and communicable with an interior of the second tube **91**.

FIG. **5** is a plan view showing the second embodiment of the blood collecting apparatus of the present invention. Description of constructions of the blood collecting apparatus of the second embodiment same as those of the blood collecting apparatus of the first embodiment is omitted herein. Thus, only the constructions of the blood collecting apparatus of the second embodiment different from those of the blood collecting apparatus of the first embodiment will be described below.

As shown in FIG. **5**, in a blood collecting apparatus **1a**, a filter **41** is provided at one end of the third tube **31**, instead of the flexible resin bag **20** of the blood collecting apparatus **1**. The filter **41**, gas-permeable and blood-unpermeable and communicable with the interior of the second tube **91**, is capable of exhausting air inside the first tube **15a** at the side the blood collecting needle **152** and air inside the second tube **91** when the blood collecting apparatus **1a** is used. Other constructions of the blood collecting apparatus **1a** are similar to those of the blood collecting apparatus **1**.

FIG. **6** is a sectional view showing an example of the construction of the filter **41** of the blood collecting apparatus **1a**.

As shown in FIG. **6**, the filter **41** comprises a tubular body **42** and a cylindrical filter member **43** gas-permeable (ventilative) and blood-unpermeable. An end of the third tube **31** is liquid-tightly connected with the lower side of the tubular body **42** in FIG. **6**. The filter member **43** is fitted into an upper portion of the tubular body **42** in FIG. **6**. The tubular body **42** is made of a hard material such as polycarbonate or the like. The filter member **43** can be made of a sintered material containing polyethylene, polypropylene or polyamide as its main component.

The operation (blood collecting method using the blood collecting apparatus) of the blood collecting apparatus **1a** is similar to that of the blood collecting apparatus **1** except that in the blood collecting apparatus **1a**, air is exhausted to the outside through the body **43** of the filter **41**. The effect of the blood collecting apparatus **1a** is also similar to that of the blood collecting apparatus **1**.

15

With reference to FIG. 5, the operation of the blood collecting apparatus 1a, namely, the blood collecting method to be carried out by using the blood collecting apparatus 1a will be described below.

The second blood collecting method is carried out by using a blood collecting apparatus 1a comprising a blood collecting needle 152 for collecting blood from a donor; a blood collecting bag 10 for accommodating collected blood; a first tube 15 whose one end communicates with the blood collecting bag 10 and other end communicates with the blood collecting needle 152; a branch portion 92 provided on a portion of the first tube 15; a second tube 91 connected with the branch portion 92 at one end thereof and having a blood take-out port 71; and a filter 41 gas-permeable and blood-unpermeable and a communicable with an interior of the second tube.

The second blood collecting method comprises the steps of piercing a blood collecting needle into a donor when a portion of the first tube positioned between the branch portion and the blood collecting bag is sealed; exhausting air inside the first and second tubes from the filter by introducing an initial flow blood from the donor into a portion of the first tube between the blood collecting needle and the branch portion and into the second; sampling blood from the initial flow blood by using the blood take-out port; and collecting a predetermined amount of blood by intercepting communication between the first tube and the filter and by communicating the portion of the first tube between the blood collecting needle and the branch portion with a portion of the first tube between the branch portion and the blood collecting bag.

The blood collecting needle-piercing step of the second embodiment is the same as that of the first embodiment. More specifically, as shown in FIG. 5, the first tube 15 (the first tube 15b at the side of the blood collecting bag 10) is sealed with the clamp 16 to close (intercept) the duct thereof. The clamp 33 is opened to open the duct of the third tube 31.

Then, the blood collecting needle 152 is pierced into the vein (blood vessel) of a donor. When it is confirmed that the blood collecting needle 152 is in the vein, the hub 151 is fixed with a tape. Then, to open the duct of the sealing member 93, the breakable portion 933 of the sealing member 93 is broken to separate the solid columnar body 932 from the cylindrical body 931.

After completing the needle-piercing step, the step of removing the air from the tubes is performed. That is, the blood (initial flow blood) of the donor is introduced into the portion of the first tube 15a and into the second tube 91 to exhaust air inside the first tube 15a and air inside the second tube 91 from the filter 41.

More specifically, the blood of the donor is introduced into the first tube (the first tube 15a at the side of the blood collecting needle) between the blood collecting needle 152 and the branch portion (first branch connector 92) and into the second tube 91 to exhaust the air inside the first tube (the first tube 15a at the side of the blood collecting needle 152) positioned between the blood collecting needle 152 and the branch portion 92 and the air inside the second tube 91 to the outside from the filter 41.

More specifically, by carrying out the needle-piercing step, the initial flow blood is introduced into the second tube 91 through the blood collecting needle 152, a part of the first tube 15 (the first tube 15a at the side of the blood collecting needle 152) and the first branch connector 92, thus flowing toward the sampling port 71. In this case, the duct of the first tube 15 is intercepted with the clamp 16. Thus, the blood flows from the first tube 15 (the first tube 15a at the side of the blood collecting needle 152) to the second tube 91 through the first branch connector 92. The blood is introduced into the second

16

tube 91 by utilizing the pressure of the vein and locating the sampling port 71 below the position at which the blood collecting needle 152 is pierced into the donor.

In introducing the initial flow blood into the second tube 91, the air inside a part of the first tube 15 (the first tube 15a at the side of the blood collecting needle), the second tube 91, and the first branch connector 92 flow into the third tube 31 through the second branch connector 32, thus being exhausted from the filter 41 positioned at the termination of the third tube. That is, because the air inside a part of the first tube 15 (the first tube 15a at the side of the blood collecting needle) and the air inside the second tube 91 are exhausted by the introduction of the blood thereinto, the pressure of the lumen of the first tube 15 and the second tube 91 do not increase. That is, because the pressure inside the first tube 15 and the second tube 91 can be kept substantially constant, it is possible to prevent an excess load from being applied to blood cells. Thus, it is possible to prevent the blood from hemolyzing. Further, it does not happen that the blood flows into the first branch connector 92 at the side of the clamp 16.

After the step of removing the air from the tubes is performed, step of sampling blood from the initial flow blood is performed. That is, the step of collecting a predetermined amount of blood from the blood take-out port (sampling port 71) is performed. In the step of sampling blood, it may be sampled a part of the initial flow blood or blood including all of the initial flow blood.

More specifically, when the blood has reached proximately to the second branch connector 32, the third tube 31 is sealed with the clamp 33 to close (intercept) the duct thereof thereby to stop the introduction of the blood.

Then, the cap 76 is removed from the body 73 of the sampling port 71. Then, the double-headed needle 84 of the holder 82 is pierced into the plug 77 of the sampling port 71 and penetrated therethrough to install the holder 82 on the sampling port 71.

Then, to collect an initial flow blood, the vacuum blood collecting tube 85 is inserted into the innermost portion of the holder 82 and pressed thereinto, and the double-headed needle 84 of the holder 82 is pierced through the rubber plug 87. As a result, the blood is sucked into the vacuum blood collecting tube 85 and collected thereby. In this case, the interior of the first tube 15 (the first tube 15a at the side of the blood collecting needle 152) and that of the second tube 91 both positioned between the blood collecting needle 152 and the sampling port 71 are mostly filled with the blood. Thus, when the double-headed needle 84 of the holder 82 is pierced through the rubber plug 87 of the vacuum blood collecting tube 85 to suck the blood into the vacuum blood collecting tube 85, an excess load can be prevented from being applied to blood cells. Thus, it is possible to prevent the blood from hemolyzing, and further, it never happens that the blood flows into the first branch connector 92 at the side of the clamp 16.

When the collecting of the initial flow blood into the first vacuum blood collecting tube 85 is completed, the vacuum blood collecting tube 85 is extracted from the holder 82. Then, as necessary, the next vacuum blood collecting tube 85 is inserted through the holder 82 and pressed into the innermost portion of the holder 82. Then, the double-headed needle 84 of the holder 82 is pierced into the rubber plug 87 and penetrated therethrough. As a result, the blood is sucked into the vacuum blood collecting tube 85 and collected thereby. This operation is repeated to collect the initial flow blood is introduced into a necessary number of the vacuum blood collecting tubes 85.

After the blood sampling into the vacuum blood collecting tube 85, i.e., after the collecting of the initial flow bloods into

the vacuum blood collecting tubes **85** terminates, the holder **82** is removed from the sampling port **71**, and then, the cap **76** is installed on the body **73** of the sampling port **71**.

Because the plug **77** is fitted on the body **73** of the sampling port **71**, the plug **77** prevents leak of the blood.

After the step of sampling blood from the initial flow blood terminates, the communication between the first tube **15** and the blood flexible resin bag **20** is intercepted and the blood collecting step is performed. That is, a predetermined amount of blood is collected by communicating the first tube **15a** with the portion of the fist tube (the first tube **15b** at the side of the blood collecting bag **10**) positioned between the branch portion and the blood collecting bag **10**.

More specifically, a main blood collecting into the blood collecting bag **10** is started. The blood collecting is performed by using a blood collecting device of decompression type or by locating the blood collecting bag **10** at a position below the position at which the blood collecting needle **152** is pierced into the donor, namely, by utilizing the difference between the levels of the two positions.

In this case, the clamp **16** is opened to open the duct of the first tube **15**. Consequently, the blood of the donor flows through the first tube **15**, thus being introduced into the blood-accommodating portion **13** of the blood collecting bag **10**.

After a predetermined amount of blood is collected, the blood collecting needle **152** is removed from the blood vessel of the donor. Then, the cap **153** is installed on the hub **151**. If necessary, the second tube **91** and the first tube **15** are fused, respectively with tube sealer or the like. Then, sealed portions of the first and second tubes **15** and **91** are cut off to remove the portion thereof located at the side of the sampling port **71**. In this manner, it is possible to obtain the blood collecting bag **10** accommodating the blood not containing the initial flow blood.

The third embodiment of the blood collecting apparatus of the present invention will be described below.

FIG. 7 is a plan view showing the third embodiment of the blood collecting apparatus of the present invention. Description of constructions of the blood collecting apparatus of the third embodiment same as those of the blood collecting apparatus of the first embodiment is omitted herein. Thus, only the constructions of the blood collecting apparatus of the third embodiment different from those of the blood collecting apparatus of the first embodiment will be described below.

As shown in FIG. 7, the blood collecting apparatus **1b** has a filter provided on the branch connector **32** and a sealable air vent **51** provided thereon. The blood collecting apparatus **1b** does not have the third tube **31**, the clamp **33**, and the flexible resin bag **20** unlike the blood collecting apparatus **1** of the first embodiment. The other constructions of the blood collecting apparatus **1b** of the third embodiment are similar to those of the blood collecting apparatus **1** of the first embodiment.

FIG. 8 is a sectional view showing an example of the sealable air vent **51** for use in the blood collecting apparatus **1b** of the present invention.

As shown in FIG. 8, the air vent (filter) **51** comprises a vent adapter **52**, an adapter cap **53**, a vent filter (filter body) **54** gas-permeable (ventilative) and blood-unpermeable, and a vent cap **55**.

The vent adapter **52** is cylindrical and has a projection **521** formed on a rotational shaft of the cylinder. The projection **521** is pressed into the second branch connector **32**.

The disk-shaped vent filter **54** is provided on the upper surface of the vent adapter **52** at the side (upper side in FIG. 8) not provided with the projection **521** such that the vent filter **54** seals the vent adapter **52**. The adapter cap **53** is installed on the periphery of the vent filter **54**.

The adapter cap **53** is disk-shaped and has an air-permeable hole **531** at its center to allow air to pass between the inner space of the second branch connector **32** and the outside through the vent filter **54**.

A projection **551** which engages the hole **531** when the vent cap **55** is installed on the vent adapter **52** is formed at the center of the vent cap **55**. When the projection **551** engages the hole **531**, a third duct (duct communicating with the inside of the second tube and the outside through the air vent **51**) is intercepted.

That is, when the vent cap **55** is installed on the vent adapter **52** (the vent cap **55** is closed), the third duct is intercepted. When the vent cap **55** is removed from the vent adapter **52** (the vent cap **55** is opened), the third duct is opened. The third duct is constituted of a hollow portion (duct) between the branch point of the second branch connector **32** and a position immediately prior to the vent cap **55** of the air vent **51**. The vent cap **55** constitutes a third duct-sealing member. The air vent (filter) **51** constitutes a main portion of the pressure buffering means.

As the vent filter **54**, it is possible to use various kinds of membrane filters such as a membrane filter consisting of a polyester resin coated with polyvinyl chloride, a membrane filter consisting of polytetrafluoroethylene laminated on or coating nonwoven cloth of polyethylene, a membrane filter consisting an acetate film coated with silicone resin, and the like.

The operation (blood collecting method using the blood collecting apparatus) of the blood collecting apparatus **1b** is similar to that of the blood collecting apparatus **1a** except that in the blood collecting apparatus **1b**, the vent cap **55** of the air vent (filter) **51** is opened and closed in the blood collecting apparatus **1b** whereas in the blood collecting apparatus **1a**, the clamp **33** of the blood collecting apparatus **1a** is opened and closed and that in the blood collecting apparatus **1b**, air is exhausted to the outside through the vent filter **54** of the air vent.

The effect of the blood collecting apparatus **1b** is also similar to that of the blood collecting apparatus **1**.

The blood collecting apparatus of the present invention and the blood collecting methods thereof using each blood collecting apparatus have been described with reference to the drawings. The present invention is not limited to the embodiments, but the construction of each part of the blood collecting apparatus of each embodiment can be replaced with a part having a desired construction provided that it has the same function as that of each part of the blood collecting apparatus of each embodiment.

For example, as shown in FIG. 9 showing a blood collecting apparatus of the fourth embodiment, the second duct may be provided with a check valve **94** (reverse flow prevention member).

FIG. 10 is a vertical sectional view showing an example of the construction of the **94**. FIG. 11 is a sectional view taken along a line A-A of FIG. 10. In the description made below, the right side in FIGS. 10 and 11 is referred to as "front side" and the left side therein is referred to as "rear side".

As shown in FIGS. 10 and 11, the check valve **94** comprises a short tube **940** composed of a flexible resin such as soft polyvinyl chloride and a body **941** made of an elastic material. The body **941** is liquid-tightly inserted into the short tube **940** and fixed thereto.

The front end of the short tube **940** is liquid-tightly connected with the sampling port **71**. The rear end of the short tube **940** is liquid-tightly connected with the second branch connector **32**.

The body **941** has a hollow portion **942** communicating with the second branch connector **32** and forming a part of the blood duct of the check valve **94**. A tapered surface **943** is formed on the front end of the hollow portion **942**. That is, the vertical length (L) of the front side of the hollow portion **942** decreases gradually from the rear side toward the front side.

A pair of plate-shaped opening/closing members **944** and **944** is formed at the front end of the body **941**. The opening/closing members **944** and **944** are in close contact with each other owing to their elastic and restoring forces, thus closing the duct of the check valve **94**. When blood flows from the front side to the rear side, the pressure of the blood is applied to the peripheral surface of the opening/closing members **944** and **944**, thus acting to bring them into contact each other closely. Thus, the blood does not flow from the front side to the rear side.

When blood flows from the rear side to the front side, a predetermined pressure of the blood is applied to the front end of the tapered surface **943**, thus acting to move the opening/closing members **944** and **944** away from each other. As a result, the duct of the check valve **94** is opened, thus flowing the blood from the rear side to the front side.

As the material composing the body **941**, rubber materials such as natural rubber, isoprene rubber, butyl rubber, silicone rubber, urethane rubber, acrylic rubber, and butadiene rubber, styrene-butadiene rubber can be preferably used.

The check valve **94** prevents a reverse flow blood. That is, the blood does not flow from the sampling port **71** toward the first branch connector **92**, but from the first branch connector **92** toward the sampling port **71**.

In the present invention, the position of the check valve **94** is not limited to a specified position as long as it is positioned on the second duct. As described above, it is favorable that the check valve **94** is positioned at the side of the sampling port **71** with respect to the second branch connector **32**. It is more favorable that the check valve **94** is positioned between the second branch connector **32** and the sampling port **71**.

When the check valve **94** is installed at the above-described position, the check valve **94** does not constitute a pressure drag when blood is flowed to a position proximate to the second branch connector **32**. Thus, the check valve **94** allows the introduction of the blood to the bag **20** to be accomplished smoothly.

As shown in FIGS. **12**, **13**, and **14**, the first duct-sealing member may be composed of a sealing member **95** which can be broken to open the first duct. That is, the clamp **16** shown in FIGS. **1**, **5**, and **7** may be replaced with the sealing member **95**. As the sealing member **95** of the blood collecting apparatus **1c**, **1d**, and **1e**, a member similar to the above-described sealing member **93** can be used.

In the present invention, the second tube **91** may be closed with a tube-closing member such as a clamp to intercept the duct (second duct). In this case, it is preferable that the tube-closing member is positioned between the first branch connector **92** and the sealing member **93**.

It is possible that the second tube **91** is not provided with the sealing member **93** when the second tube **91** is provided with the tube-closing member.

In the present invention, in the construction shown in FIGS. **1** and **5**, it is possible to connect the sampling port **71** and the third tube **31** to the end of each branch of the second branch connector **32** reversely. That is, the third tube **31** may be connected with the end of the upper branch of the second branch connector **32** in FIGS. **1** and **5** and the sampling port **71** may be connected with the end of the lower branch thereof in FIGS. **1** and **5**.

In the present invention, in the construction shown in FIG. **7**, it is possible to connect the sampling port **71** and the air vent **51** to the end of each branch of the second branch connector **32** reversely. That is, the air vent **51** may be connected with the end of the upper branch of the second branch connector **32** in FIG. **7** and the sampling port **71** may be connected with the end of the lower branch thereof in FIG. **7**.

In the present invention, the branch portions may be composed of a multi-plug such as a three-way plug instead of the branch connectors as shown in the drawings.

As described above, according to the blood collecting apparatus of the present invention and the blood collecting method thereof, air inside the first tube **15** (first tube **15a** at the side of the blood collecting needle **152**) between the branch portion **92** and the blood collecting needle **152** and air inside the second tube **91** can be accommodated in the flexible resin or exhausted to the outside. Thus, an initial flow blood is prevented from being left in the branch portion between the first tube and the second tube at the side of the blood collecting bag. That is, it is possible to collect blood not containing a initial part of the initial flow blood having a probability of microbism easily and reliably from blood collected from a donor. Thus, it is possible to prevent inclusion of bacteria into the collected blood or respective components separated from the collected blood, thus having a high degree of safety.

As described above, because the blood collecting apparatus of the present invention has the pressure buffering means for restraining fluctuation of the pressure in the second duct, the initial flow blood is prevented from being left in the branch portion between the first tube and the second tube at the side of the blood collecting bag. That is, it is possible to remove the initial flow blood having a probability of microbism easily and reliably from blood collected from a donor. Therefore, it is possible to prevent inclusion of bacteria into the collected blood or respective components separated from the collected blood, thus having a high degree of safety.

When the initial flow blood is collected (when examining blood is collected), the pressure buffering means prevents (prevents cells in blood from being damaged, for example, hemolysis) an excess load from being applied to the blood, thus allowing the initial flow blood to be collected in a preferable state and preventing a collecting amount of the initial flow blood from being reduced.

EXAMPLES

The examples of the blood collecting apparatus of the present invention will be described below.

Example 1

The blood collecting apparatus **1** shown in FIG. **1** was prepared. Two soft polyvinyl sheets were used as the material of the flexible resin bag **20**. They were laminated on each other and the peripheral edges thereof were fused to each other. The bag **20** had a capacity of 20 ml. Using the blood collecting apparatus **1** and the method previously described, air inside the first tube **15a** positioned at the side of the blood collecting needle and air inside the second tube **91** were introduced into the bag **20** by introducing an initial flow blood. Then, an initial part of the initial flow blood was collected in the vacuum blood collecting tube **85**. Then, 200 ml of blood was collected in the blood collecting bags **10**. The blood sampling capacity of each vacuum blood collecting tube **85** was 10 ml.

Example 2

The blood collecting apparatus **1a** shown in FIG. **5** was prepared. The body **43** of the filter **41** provided on the third

21

tube **31** was made of a sintered material containing polypropylene as its main component. Using the blood collecting apparatus **1a** and the method previously described, air inside the first tube **15a** positioned at the side of the blood collecting needle and air inside the second tube **91** were discharged from the filter by introducing an initial flow blood. Then, a initial part of the initial flow blood was collected in the vacuum blood collecting tube **85**. Then, 200 ml of blood was collected by the blood collecting bag **10**. The blood sampling capacity of each vacuum blood collecting tube **85** was 10 ml.

Example 3

The blood collecting apparatus **1b** shown in FIG. **7** was prepared. As the vent filter **54** of the air vent (filter) **51** provided at the second branch portion **32**, a membrane filter made of polytetrafluoroethylene was used. Using the blood collecting apparatus **1b** and the method previously described, air inside the first tube **15a** positioned at the side of the blood collecting needle and air inside the second tube **91** were discharged through the vent filter **54** by introducing an initial flow blood. Then, a initial part of the initial flow blood was collected in the vacuum blood collecting tube **85**. Then, 200 ml of blood was collected by the blood collecting bag **10**. The blood sampling capacity of each vacuum blood collecting tube **85** was 10 ml.

Comparison Example 1

Except that a blood collecting apparatus did not have the second branch connector **32**, the third tube **31**, the clamp **33**, and the flexible resin bag **20**, the blood collecting apparatus had a construction similar to that of the embodiment 1. Using the blood collecting apparatus and a method similar to that of the embodiment 1 except the operation of clamp **33**, an initial part of an initial flow blood was collected in the vacuum blood collecting tube **85**. Then, 200 ml of blood was collected by the blood collecting bag **10**. The blood sampling capacity of each vacuum blood collecting tube **85** was 10 ml.

Comparison Example 2

Except that a blood collecting apparatus did not have the second branch connector **92**, the second tube **91**, the sealing member **93**, the branch connector **32**, the third tube **31**, the clamp **33**, and the flexible resin bag **20**, the blood collecting apparatus had a construction similar to that of the embodiment 1. Using the blood collecting apparatus and a conventional method, 200 ml of blood was collected by the blood collecting bag **10**.

[Test]

In any of the first-third embodiments and comparison examples 1 and 2, a bacterium fluid of *Yersinia enterocolitica* (buffer and suspension of phosphoric acid, concentration: 100 cfu/ml.) was applied to a donor at a predetermined piercing portion thereof with swabs once a day for a week before blood was collected from them. The piercing portions of the donors were not washed for a week before blood was collected therefrom.

The following bacteria culture tests were conducted by using the blood collected in the blood collecting bags used in the first-third embodiments and comparison examples 1 and 2.

(Bacterium-culturing Test)

200 ml of blood accommodated in the blood collecting bag **10** was mixed with a blood conservation liquid accommodated therein. Then, an operation adapter was pierced into an

22

opening **14** of the blood collecting bag **10**. Using a syringe and a needle installed thereon, about 50 ml of blood was aseptically collected from a rubber plug of the operation adapter. The blood was injected into glass containers accommodating a culture medium described below to culture it.

After culturing 25 bloods (25 donors) in a condition described below, the number of the bloods having bacteria was examined. The culture medium and the culture condition were as follows:

Culture medium: Brain Heart Infusion w/PAB and CO₂, Under Vacuum (manufactured by Difco Corp.)

Culture amount: 50 ml

Culture temperature: 25-30° C.

Observation time period (culture time period): 10 days

The result of the bacterium culture test is shown in table 1 below.

TABLE 1

	Number of bloods (Number of donors)	Number of Bacterium Deleted Bloods
Example 1	25	0
Example 2	25	0
Example 3	25	0
Comparison example 1	25	5
Comparison example 2	25	5

In the first-third embodiments, in the introduction of an initial flow blood into each vacuum blood collecting tube, the tube in the range from the blood collecting needle to the sampling port was substantially filled with blood. Because the initial flow blood was collected into each vacuum blood collecting tube installed on the holder, it did not occur that the blood flowed to the first branch connector **92** at the side of the clamp **16**. Thus, blood collected from the donor did not contain the initial flow blood. Therefore, as indicated in table 1, the number of bacterium-detected bloods was zero.

On the other hand, because in comparison example 2, collected blood contained the initial flow blood, many collected bloods contained bacteria.

In comparison example 1, because air inside the tube could not be exhausted to the outside when an initial flow blood was introduced into a vacuum blood collecting tube, the tube in the range from the blood collecting needle to the sampling port could not be filled with the blood. Thus, immediately after the vacuum blood collecting tube was installed on the holder, the inside of the circuit was filled with blood to restore a decompressed state to a normal pressure state. At that time, in some cases, the initial flow blood flowed into the first branch connector **92** at the side of the clamp **16**, thus mixing with collected blood. Therefore, it was impossible to make the number of bacterium-detected bloods zero.

[Hemolysis Test]

Table 2 indicates the degree of hemolysis (number of detected hemolysis) of each collected blood introduced into each vacuum blood collecting tube **85** and average values of the amounts of the initial flow blood introduced into the vacuum blood collecting tubes **85**.

The degree of hemolysis of the initial flow of each collected blood was examined as follows: After blood coagulated, blood serum was centrifuged at 300 rpm for 10 minutes to visually observe the tone of each blood serum. According to the tone of red, the degree of hemolysis of the initial flow of each collected blood was determined by using the following three levels, namely, not hemolyzed (level 0), slightly hemolyzed (level 1), and hemolyzed (level 2).

23

Not hemolyzed (level 0): Tone of red was not observed.

Slightly hemolyzed (level 1): Tone of red was observed in a slight degree.

Hemolyzed (level 2): Tone of red was observed.

“Slightly hemolyzed” (level 1) was also regarded as “hemolyzed” cases. The number of detected “hemolyzed” cases was determined.

TABLE 2

	Number of Bloods (Donors)	Number of Hemolysis (Visual)	Sampling Blood Volume Average (Graduated Cylinder)
Example 1	25	0	9.8 ml
Example 2	25	0	9.8 ml
Example 3	25	0	9.8 ml
Comparison Example 1	25	2	6.5 ml

In the first-third embodiments, the introduction of an initial flow blood into each vacuum blood collecting tube, the tube in the range from the blood collecting needle to the sampling port was substantially filled with blood. Because the initial flow blood was collected into each vacuum blood collecting tube installed on the holder, an excess load was not applied to blood. Thus, the blood did not hemolyze as indicated in table 2 below. That is, in the first-third embodiments, slight degree of hemolysis (level 1) and hemolysis (level 2) were not observed.

In the first-third embodiments, in the introduction of the initial flow blood into each vacuum blood collecting tube, each vacuum blood collecting tube was installed on the holder, with the tube in the range from the blood collecting needle to the sampling port being substantially filled with blood. Thus, as indicated in table 2 below, the amount of the initial flow blood was not reduced.

On the other hand, in comparison example 1, hemolysis was observed. That is, slight hemolysis (level 1) was observed in two glass containers. In the comparison example 1, the inside of the tube in the range from the blood collecting needle to the sampling port could not be filled with blood. Thus, immediately after the vacuum blood collecting tube was installed on the holder, air inside the tube was sucked thereinto. Consequently, the interior of the tube was decompressed and thus the tube was crushed. Thus, it is assumed that when blood flowed through the tube, red blood cells were damaged.

In comparison example 1, the initial flow blood was introduced into the vacuum blood collecting tube, without the inside of the tube in the range from the blood collecting needle to the sampling port being filled with blood. Thus, air inside the tube was sucked into the vacuum blood collecting tube and collected therein. Consequently, the amount of the initial flow of collected blood was reduced by 3.5 ml corresponding to the spatial volume of the length (35 cm) of the tube.

What is claimed is:

[1. A blood collecting apparatus comprising:

a blood collecting needle for collecting blood from a donor;

a blood collecting bag for accommodating collected blood; a first tube whose one end communicates with said blood collecting bag and other end communicates with said blood collecting needle;

a first branch portion provided on a portion of said first tube,

24

a second tube connected with said first branch portion at one end thereof and having a second branch portion provided on a portion of said second tube;

a blood take-out port communicating to one branch port of said second branch portion;

a filter gas-permeable and blood-unpermeable and communicable with an interior of another branch port of said second branch portion; and

a cap for opening and closing said filter.]

[2. A blood collecting apparatus according to claim 1, further comprising a duct-sealing member positioned between said first branch portion and said blood collecting bag and capable of intercepting a duct inside said first tube.]

[3. A blood collecting apparatus according to claim 1, further comprising a duct-sealing member capable of intercepting a duct inside said second tube.]

[4. A blood collecting apparatus according to claim 2, wherein said duct-sealing member consists of a breakable sealing member which opens said duct of each of said first and second tubes when said breakable sealing member is broken or a clamp member which can be opened and closed.]

[5. A blood collecting apparatus according to claim 1, wherein said filter is installed on said one branch port of said second branch portion.]

[6. A blood collecting apparatus according to claim 1, further comprising a reverse flow prevention member allowing a flow from said first branch portion provided on said first tube to said blood take-out port and preventing a flow reverse to said flow from said first branch portion to said blood take-out port.]

[7. A blood collecting apparatus according to claim 1, wherein an area of a sectional surface of said duct inside said second tube is smaller than an area of a sectional surface of said duct inside said first tube.]

[8. A blood collecting apparatus according to claim 1, wherein a needle of a blood collecting tool for a vacuum blood collecting tube can be pierced into said blood take-out port.]

9. In a blood collecting apparatus comprising:

a blood collecting needle for collecting blood from a donor;

a blood collecting bag for accommodating collected blood; a first duct whose one end communicates with said blood collecting bag and other end communicates with said blood collecting needle, and introducing said collected blood into said blood collecting bag;

a second duct branching from said first duct through a branch portion and having a blood take-out port; and a pressure buffering means for suppressing fluctuation of a pressure of said second duct;

wherein said pressure buffering means has a flexible resin bag;

wherein said pressure buffering means has a third duct branching from said second duct through a branch portion; and said flexible resin bag is provided at an end of said third duct.

[10. A blood collecting apparatus according to claim 9, wherein said pressure buffering means has a flexible resin bag.]

11. A blood collecting apparatus according to claim [10] 9, wherein a capacity of said *flexible resin* bag member is in the range of 1-100 ml.

[12. A blood collecting apparatus according to claim 10, wherein said pressure buffering means has a third duct branching from said second duct through a branch portion; and said bag member is provided at an end of said third duct.]

25

[13. A blood collecting apparatus according to claim 9, wherein said pressure buffering means has a filter gas-permeable and blood-unpermeable.]

[14. A blood collecting apparatus according to claim 13, wherein said pressure buffering means has a third duct branching from said second duct through a branch portion; and said filter is provided to said third duct.]

15. A blood collecting apparatus according to claim [12] 9, further comprising a third duct-sealing member capable of intercepting said third duct.

16. A blood collecting apparatus according to claim 9, further comprising a reverse flow prevention member allowing a flow from a branch portion from which said first duct and said second duct branch each other to said blood take-out port and preventing a flow reverse to said flow from said branch portion to said blood take-out port.

[17. A blood collecting apparatus according to claim 9, further comprising a first duct-sealing member capable of intercepting a portion of said first duct between a branch portion from which said first duct and said second duct branch each other and said blood collecting bag.]

[18. A blood collecting apparatus according to claim 17, wherein said first duct-sealing member consists of a breakable sealing member which opens said first duct when said breakable sealing member is broken.]

19. A blood collecting apparatus according to claim 9, further comprising a second duct-sealing member capable of intercepting said second duct.

20. A blood collecting apparatus according to claim 19, wherein said second duct-sealing member has a breakable sealing member which opens said second duct when said breakable sealing member is broken.

21. A blood collecting apparatus according to claim 9, wherein an area of a sectional surface of said second duct is smaller than an area of a sectional surface of said first duct.

22. A blood collecting method to be carried out by using a blood collecting apparatus comprising: a blood collecting needle for collecting blood from a donor; a blood collecting bag for accommodating collected blood; a first tube whose one end communicates with said blood collecting bag and other end communicates with said blood collecting needle; a branch portion provided on a portion of said first tube; a second tube connected with said branch portion at one end thereof and having a blood take-out port at the other end thereof; and a flexible resin bag and having a third tube communicating with said second tube,

said blood collecting method comprising the steps of:

piercing a blood collecting needle into a donor when a portion of said first tube positioned between said branch portion and said blood collecting bag is sealed; removing air inside said first and second tubes by introducing an initial flow blood from said donor into a portion of said first tube between said blood collecting needle and said branch portion and into said second tube and by accommodating air inside said portion of the first tube positioned between said blood collecting needle and said branch portion and air inside said second tube in said flexible resin bag; and

collecting a predetermined amount of blood from said donor in said blood collecting bag by intercepting communication between said first tube and said flexible resin bag and by communicating said portion of said first tube between said blood collecting needle and said branch portion with a portion of said first tube between said branch portion and said blood collecting bag.

26

23. A blood collecting method according to claim 22, further comprises the step of sampling blood from said initial flow blood by using said blood take-out port after the step of removing air and before the step of collecting a predetermined amount of blood.

24. A blood cell collecting method according to claim 23, wherein the step of sampling blood from said initial flow blood is performed by connecting a vacuum blood collecting tool with said blood take-out port.

25. A blood collecting method according to claim 23, wherein the step of sampling blood from said initial flow blood is performed by intercepting communication between said second tube and said flexible resin bag.

[26. A blood collecting method to be carried out by using a blood collecting apparatus comprising a blood collecting needle for collecting blood from a donor; a blood collecting bag for accommodating collected blood; a first tube whose one end communicates with said blood collecting bag and other end communicates with said blood collecting needle; a branch portion provided on a portion of said first tube; a second tube connected with said branch portion at one end thereof and having a blood take-out port at the other end thereof; and a filter gas-permeable and blood-unpermeable and communicable with an interior of said second tube,

said blood collecting method comprising the steps of:

piercing a blood collecting needle into a donor when a portion of said first tube positioned between said branch portion and said blood collecting bag is sealed; exhausting air inside said first and second tubes from said filter by introducing an initial flow blood from said donor into a portion of said first tube between said blood collecting needle and said branch portion and into said second tube;

collecting a predetermined amount of blood from said donor in said blood collecting bag by intercepting communication between said first tube and said filter and by communicating said portion of said first tube between said blood collecting needle and said branch portion with a portion of said first tube between said branch portion and said blood collecting bag.]

[27. A blood collecting method according to claim 26, further comprises the step of sampling blood from said initial flow blood by using said blood take-out port after the step of removing air and before the step of collecting a predetermined amount of blood.]

[28. A blood collecting method according to claim 27, wherein the step of sampling blood from said initial flow blood is performed by connecting a vacuum blood collecting tool with said blood take-out port.]

[29. A blood collecting method according to claim 25, wherein the step of sampling blood from said initial flow blood is performed by intercepting communication between said second tube and said filter.]

[30. A blood collecting apparatus comprising:

a blood collecting needle for collecting blood from a donor;
a blood collecting bag for accommodating collected blood;
a first tube having one end communicating with said blood collecting bag and another end communicating with said blood collecting needle;
a first branch portion provided on a portion of said first tube;
a second tube having one end connected with said first branch portion and having a second branch portion provided on a portion of said second tube,
a blood take-out port communicating to one branch port of the second branch portion;

a third tube having one end connected with another branch port of said second branch portion,
 a filter gas-permeable and blood-unpermeable and provided on said third tube; and
 a duct-sealing member provided on said third tube and positioned in a region between said second branch portion and said filter and adapted to intercept a duct inside said third tube.]

[31. A blood collecting apparatus according to claim 30, wherein said duct-sealing member is an openable and closable clamp member.]

[32. A blood collecting apparatus according to claim 30, further comprising a second duct-sealing member positioned between said first branch portion and said blood collecting bag and adapted to intercept a duct inside said first tube.]

[33. A blood collecting apparatus according to claim 30, further comprising a second duct-sealing member adapted to intercept a duct inside said second tube.]

[34. A blood collecting apparatus according to claim 33, wherein said second duct-sealing member includes a breakable sealing member which opens said duct of each of said first and second tubes when said breakable sealing member is broken or an openable and closable clamp member.]

[35. A blood collecting apparatus according to claim 30, further comprising a reverse flow prevention member allowing a flow from said first branch portion to said blood take-out port and preventing a flow reverse to said flow from said branch portion to said blood take-out port.]

[36. A blood collecting apparatus according to claim 30, wherein a needle of a blood collecting tool for a vacuum blood collecting tube can be pierced into said blood take-out port.]

37. *A blood collecting apparatus comprising:*
a blood collecting needle for collecting blood from a donor, said blood including initial flow blood obtained from the donor;
a blood collecting bag for accommodating collected blood not containing said initial flow blood;
a first duct whose one end communicates with said blood collecting bag and other end communicates with said blood collecting needle, and introducing said collected blood into said blood collecting bag;
a second duct branching from said first duct through a branch portion provided on said first duct and having a blood take-out port for sampling blood from said initial flow blood introduced into said second duct;
a first duct-sealing member capable of intercepting a portion of said first duct between said branch portion and said blood collecting bag and having a breakable sealing member which opens said first duct when said breakable sealing member is broken; and
a pressure buffering means for suppressing fluctuation of a pressure of said second duct, said pressure buffering means having a flexible resin bag communicating to said second duct and accommodating air received from

inside a portion of the first duct positioned between said blood collecting needle and said branch portion and air received from inside said second duct by said initial flow blood introduced into said portion of the first duct positioned between said blood collecting needle and said branch portion.

38. *A blood collecting apparatus according to claim 37, wherein a capacity of said flexible resin bag is in the range of 1-100 ml.*

39. *A blood collecting apparatus according to claim 37, further comprising a reverse flow prevention member allowing a flow from said branch portion from which said first duct and said second duct branch each other to said blood take-out port and preventing a flow reverse to said flow from said branch portion to said blood take-out port.*

40. *A blood collecting apparatus according to claim 37, further comprising a second duct-sealing member for intercepting said second duct.*

41. *A blood collecting apparatus according to claim 37, wherein said second duct-sealing member has a breakable sealing member which opens said second duct when said breakable sealing member is broken.*

42. *A blood collecting apparatus according to claim 37, wherein an area of a sectional surface of said second duct is smaller than an area of a sectional surface of said first duct.*

43. *A blood collecting apparatus comprising:*
a blood collecting needle for collecting blood from a donor, said blood including initial flow blood obtained from the donor;

a blood collecting bag for accommodating collected blood not containing said initial flow blood;

a first duct whose one end communicates with said blood collecting bag and other end communicates with said blood collecting needle, and introducing said collected blood into said blood collecting bag;

a second duct branching from said first duct through a branch portion provided on said first duct and having a blood take-out port for collecting at least some of said initial flow blood;

a pressure buffering means for suppressing fluctuation of a pressure of said second duct; and

a first duct-sealing member for intercepting a portion of said first duct between said branch portion and said blood collecting bag;

wherein said pressure buffering means includes a flexible resin bag for accommodating air received from inside a portion of the first duct positioned between said blood collecting needle and said branch portion and air received from inside said second duct, while said first duct is connected between said blood collecting bag and said blood collecting needle; and

said first duct-sealing member has a breakable sealing member which opens said first duct when said breakable sealing member is broken.