

US00RE43143E

(19) **United States**
(12) **Reissued Patent**
Hayhurst

(10) **Patent Number:** **US RE43,143 E**
(45) **Date of Reissued Patent:** **Jan. 24, 2012**

(54) **TISSUE MANIPULATION**
(76) Inventor: **John O. Hayhurst**, Wilsonville, OR
(US)
(21) Appl. No.: **11/292,385**
(22) Filed: **Dec. 2, 2005**

2,065,659 A 12/1936 Cullen
2,069,878 A 2/1937 Flood
2,075,508 A 3/1937 Davidson
2,108,206 A 2/1938 Meeker
2,302,986 A 11/1942 Vollrath
2,381,050 A 8/1945 Hardinge
2,397,545 A 4/1946 Hardinge
2,562,419 A 7/1951 Ferris
2,581,564 A 1/1952 Villegas
2,669,774 A 1/1954 Livingston
2,685,877 A 8/1954 Dobelle
2,699,774 A 1/1955 Livingston
2,745,308 A 5/1956 Gisondi
2,833,284 A 5/1958 Springer
2,883,096 A 4/1959 Dawson

Related U.S. Patent Documents

Reissue of:
(64) Patent No.: **6,656,182**
Issued: **Dec. 2, 2003**
Appl. No.: **08/423,963**
Filed: **Apr. 18, 1995**

U.S. Applications:
(63) Continuation of application No. 08/048,922, filed on Apr. 15, 1993, now Pat. No. 5,417,691, which is a continuation of application No. 07/192,813, filed on Apr. 20, 1988, now abandoned, which is a continuation-in-part of application No. 06/848,341, filed on Apr. 4, 1986, now Pat. No. 4,741,330, which is a continuation of application No. 06/496,116, filed on May 19, 1983, now abandoned, which is a continuation-in-part of application No. 06/380,043, filed on May 20, 1982, now abandoned.

(51) **Int. Cl.**
A61B 17/04 (2006.01)
(52) **U.S. Cl.** **606/232**; 606/233
(58) **Field of Classification Search** 606/72-75,
606/88, 90, 103, 144, 146, 148-153, 155-157,
606/232-233
See application file for complete search history.

(56) **References Cited**

U.S. PATENT DOCUMENTS

1,131,155 A 3/1915 Murphy
1,153,450 A 9/1915 Schaff

(Continued)

FOREIGN PATENT DOCUMENTS

CH 632 922 11/1982

(Continued)

OTHER PUBLICATIONS

Smith & Nephew, Inc. v. Biomet, Inc. and Arthrotek, Inc., Civil No. CV 05-611 JE, Plaintiffs' Amended Claim Chart in Support of Motion for Preliminary Injunction, Jul. 7, 2005, 9 pages.

(Continued)

Primary Examiner — Michael A. Brown
(74) *Attorney, Agent, or Firm* — Fish & Richardson P.C.

(57) **ABSTRACT**

An apparatus and method for manipulating and anchoring tissue is provided. The invention is directed to solving the problem of manipulating and anchoring tissue within a joint when access to that tissue is limited, for example, during arthroscopic surgery.

47 Claims, 3 Drawing Sheets

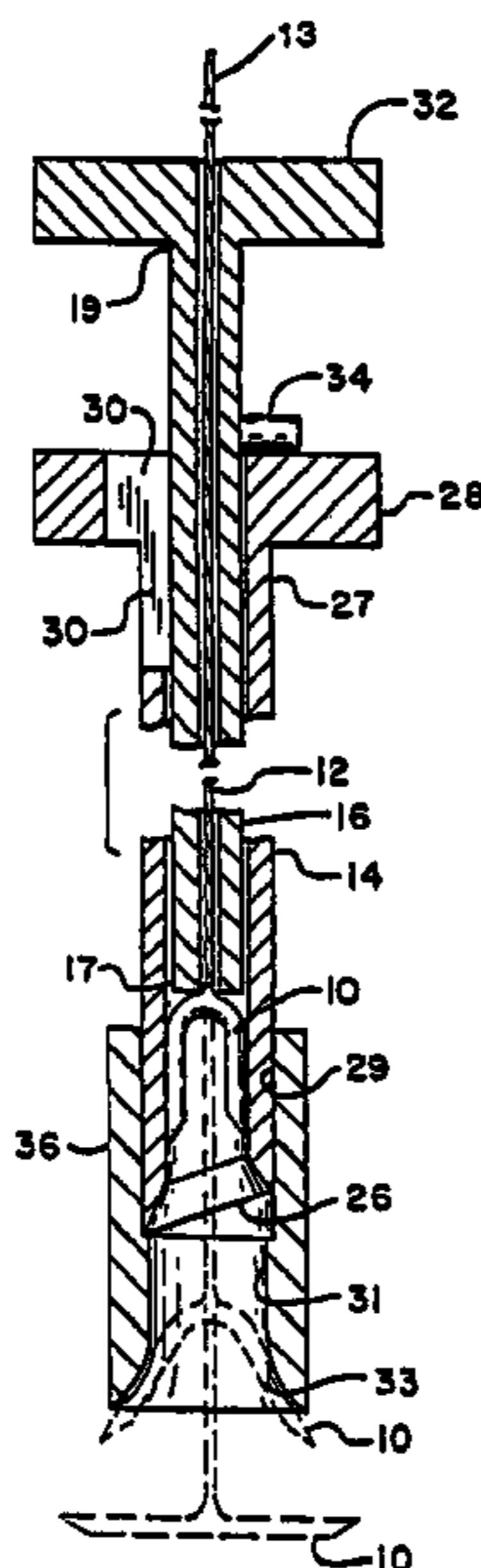

US RE43,143 E

U.S. PATENT DOCUMENTS							
2,901,796	A	9/1959	Hope	4,326,531	A	4/1982	Shimonaka
3,003,155	A	10/1961	Mielzynski et al.	4,400,833	A	8/1983	Kurland
3,028,646	A	4/1962	Janes	4,402,445	A	9/1983	Green
3,090,386	A	5/1963	Curtis	4,409,974	A	10/1983	Freedland
3,103,666	A	9/1963	Bone	4,414,967	A	11/1983	Shapiro
3,123,077	A	3/1964	Alcamo	4,438,769	A	3/1984	Pratt et al.
3,176,316	A	4/1965	Bodell	4,447,915	A	5/1984	Weber
3,209,422	A	10/1965	Dritz	4,450,591	A	5/1984	Rappaport
3,312,139	A	4/1967	DiCristina	4,454,875	A	6/1984	Pratt
3,399,432	A	9/1968	Merser	4,456,006	A	6/1984	Wevers et al.
3,470,834	A	10/1969	Bone	4,462,395	A	7/1984	Johnson
3,470,875	A	10/1969	Johnson	4,462,402	A	7/1984	Burgio et al.
3,494,004	A	2/1970	Bone	4,467,478	A	8/1984	Jurgutis
3,500,820	A	3/1970	Almén	4,469,101	A	9/1984	Coleman et al.
3,515,132	A	6/1970	McKnight	4,473,984	A	10/1984	Lopez
3,518,729	A	7/1970	Merser	4,483,678	A	11/1984	Nishio et al.
3,527,223	A	9/1970	Shein	4,487,210	A	12/1984	Knudsen et al.
3,541,591	A	11/1970	Hoegerman	4,493,323	A	1/1985	Albright et al.
3,547,389	A	12/1970	Mitchell	4,505,274	A	3/1985	Speelman
3,570,497	A	3/1971	Lemole	4,519,392	A	5/1985	Lingua
3,618,447	A	11/1971	Goins	4,523,587	A	6/1985	Frey
3,664,345	A	5/1972	Dabbs et al.	4,532,926	A	8/1985	O'Holla
3,675,639	A	7/1972	Cimber	4,537,185	A	8/1985	Stednitz
3,695,271	A	10/1972	Chodorow	4,545,875	A	10/1985	Riley
3,699,969	A	10/1972	Allen	4,548,202	A	10/1985	Duncan
3,707,006	A	12/1972	Bokros et al.	4,570,623	A	2/1986	Ellison et al.
3,708,883	A	1/1973	Flander	4,584,722	A	4/1986	Levy et al.
3,716,058	A	2/1973	Tanner, Jr.	4,590,928	A	5/1986	Hunt et al.
3,739,773	A	6/1973	Schmitt et al.	4,592,356	A	6/1986	Gutierrez
3,745,590	A	7/1973	Stubstad	4,602,635	A	7/1986	Mulhollan et al.
3,757,629	A	9/1973	Schneider	4,602,636	A	7/1986	Noiles
3,845,772	A	11/1974	Smith	4,620,541	A	11/1986	Gertzman et al.
3,871,368	A	3/1975	Johnson et al.	4,621,640	A	11/1986	Mulhollan et al.
3,875,648	A	4/1975	Bone	4,627,437	A	12/1986	Bedi et al.
3,894,467	A	7/1975	Brescia	4,632,100	A	12/1986	Somers et al.
3,896,504	A	7/1975	Fischer	4,635,637	A	1/1987	Schreiber
3,910,281	A	10/1975	Kletschka et al.	4,653,486	A	3/1987	Coker
3,924,276	A	12/1975	Eaton	4,662,886	A	5/1987	Moorse et al.
3,931,667	A	1/1976	Merser et al.	4,667,675	A	5/1987	Davis
3,943,932	A	3/1976	Woo	4,669,473	A	6/1987	Richards et al.
3,953,896	A	5/1976	Treace	4,696,300	A	9/1987	Anderson
3,954,103	A	5/1976	Garcia-Roel et al.	4,705,040	A	11/1987	Mueller et al.
3,973,277	A	8/1976	Semple et al.	4,708,132	A	11/1987	Silvestrini
3,973,299	A	8/1976	Keefe	4,738,255	A	4/1988	Goble et al.
3,976,079	A	8/1976	Samuels et al.	4,741,330	A	5/1988	Hayhurst
3,977,050	A	8/1976	Perez	4,750,492	A	6/1988	Jacobs
3,979,799	A	9/1976	Merser et al.	4,754,749	A	7/1988	Tsou
3,981,051	A	9/1976	Brumlik	4,772,286	A	9/1988	Goble et al.
3,988,783	A	11/1976	Treace	4,776,328	A	10/1988	Frey et al.
3,990,619	A	11/1976	Russell	4,781,190	A	11/1988	Lee
4,006,747	A	2/1977	Kronenthal et al.	4,790,303	A	12/1988	Steffee
4,011,602	A	3/1977	Rybicki et al.	4,804,383	A	2/1989	Rey et al.
4,013,071	A	3/1977	Rosenberg	4,834,757	A	5/1989	Brantigan
4,039,078	A	8/1977	Bone	4,841,960	A	6/1989	Garner
4,091,806	A	5/1978	Aginsky	4,870,957	A	10/1989	Goble et al.
4,094,313	A	6/1978	Komamura et al.	4,871,289	A	10/1989	Choiniere
4,103,690	A	8/1978	Harris	4,873,976	A	10/1989	Schreiber
4,121,487	A	10/1978	Bone	4,887,601	A	12/1989	Richards
4,144,876	A	3/1979	DeLeo	4,895,148	A	1/1990	Bays et al.
4,149,277	A	4/1979	Bokros	4,898,156	A	2/1990	Gattorna et al.
4,160,453	A	7/1979	Miller	4,899,743	A	2/1990	Nicholson et al.
4,185,636	A	1/1980	Gabbay et al.	4,968,315	A	11/1990	Gattorna
4,235,161	A	11/1980	Kunreuther	4,976,715	A	12/1990	Bays et al.
4,235,238	A	11/1980	Ogiu et al.	5,013,316	A	5/1991	Goble et al.
4,237,779	A	12/1980	Kunreuther	5,037,422	A	8/1991	Hayhurst
4,243,037	A	1/1981	Smith	5,049,155	A	9/1991	Bruchman et al.
4,255,820	A	3/1981	Rothermel et al.	5,084,050	A	1/1992	Draenert
4,259,072	A	3/1981	Hirabayashi et al.	5,100,417	A	3/1992	Cerier et al.
4,259,959	A	4/1981	Walker	5,224,946	A	7/1993	Hayhurst et al.
4,263,903	A	4/1981	Griggs	5,261,914	A	11/1993	Warren
4,275,490	A	6/1981	Bivins	5,400,805	A	3/1995	Warren
4,275,717	A	6/1981	Bolesky	5,417,691	A	5/1995	Hayhurst
4,279,249	A	7/1981	Vert et al.	5,437,680	A	8/1995	Yoon
4,287,807	A	9/1981	Pacharis et al.	5,601,557	A	2/1997	Hayhurst
4,289,124	A	9/1981	Zickel	5,647,874	A	7/1997	Hayhurst
4,291,698	A	9/1981	Fuchs et al.	5,690,676	A	11/1997	DiPoto et al.
4,301,551	A	11/1981	Dore et al.	6,656,182	B1	12/2003	Hayhurst
4,316,469	A	2/1982	Kapitanov				606/232

FOREIGN PATENT DOCUMENTS

DE	3 146 634	A1	11/1981
DE	31 36 083		3/1983
DE	233 303		2/1986
DE	3 710 587		3/1987
EP	0 040 884		12/1981
EP	0 083 028		7/1983
EP	0129422	*	12/1984
EP	0241240	*	10/1987
EP	A-0241240		10/1987
EP	0 317 406		5/1989
EP	88904139		11/1991
FR	2 422 386		4/1978
FR	2 590 792		6/1987
FR	2 606 270		5/1988
FR	2 622 790		5/1989
GB	284898		2/1928
GB	1 602 834		11/1981
GB	A-2118474		11/1983
GB	2118474	*	11/1991
WO	WO8603666	*	7/1986
WO	WO-A-8603666		7/1986
WO	WO8701270	*	3/1987
WO	WO-A-8701270		3/1987

OTHER PUBLICATIONS

Smith & Nephew, Inc. v. Arthrex, Inc., Civil No. 04-0029 ST, Deposition of John O. Hayhurst, MD, Jan. 24, 2007, including exhibits, A-234, A-241 through 245, A-249, DDX004 (Confidential Material Redacted).

Deposition excerpt: John O. Hayhurst; US District Court, Oregon, Case No. CV04-0029ST pp. 1, 13-18; 77-86; 93-99; Errata Sheet (1 page) and Exhibit 15 (1 page) Nov. 4, 2004.

Smith & Nephew, Inc. v. Arthrex, Inc., Civil No. CV 04-0029 MO, Smith & Nephew's Opening Claim Construction Brief, Nov. 30, 2006, 41 pages.

Smith & Nephew, Inc. v. Arthrex, Inc., Civil No. CV 04-0029 MO, Smith & Nephew's Opening Brief in Support of its Motion for Summary Judgment, Nov. 30, 2006, 79 pages (Confidential Material Redacted).

Smith & Nephew, Inc. v. Arthrex, Inc., Civil No. CV 04-0029 MO, Omnibus Declaration of Brenna K. Legaard in Support of Smith & Nephew's Opening Claim Construction and Summary Judgment Briefs, 10 pages, with Exhibits 1-25, 48-56, 58-69 and 71-80, Nov. 30, 2006 (Confidential Material Redacted).

Smith & Nephew, Inc. v. Arthrex, Inc., Civil No. CV 04-0029 MO, Arthrex's Memorandum in Support of its Motion for Summary Judgment of Invalidity Over Prior Art, Nov. 30, 2006, 21 pages.

Smith & Nephew, Inc. v. Arthrex, Inc., Case No. CV 04-0029 MO, Declaration of Anthony P. Cho in Support of Arthrex Inc.'s Motion for Summary Judgment of Invalidity, 3 pages, with Exhibits A-F, Nov. 30, 2006.

Smith & Nephew, Inc. v. Arthrex, Inc., Case No. CV 04-0029 MO, Arthrex, Inc.'s Memorandum in Support of its Motion for Summary Judgment of Invalidity for Double Patenting, Nov. 30, 2006, 15 pages.

Smith & Nephew, Inc. v. Arthrex, Inc., Case No. CV 04-0029 MO, Declaration of Anthony P. Cho in Support of Arthrex, Inc.'s Motion for Summary Judgment of Invalidity for Double Patenting, 3 pages, with Exhibits A-G, Nov. 30, 2006.

Smith & Nephew, Inc. v. Arthrex, Inc., Case No. CV 04-0029 MO, Declaration of Anthony P. Cho in Support of Arthrex, Inc.'s Markman Brief, 6 pages, with Exhibits A-FF, Nov. 30, 2006.

Smith & Nephew, Inc. v. Arthrex, Inc., Case No. CV 04-0029 MO, Arthrex, Inc.'s Corrected Markman Brief, Request for Oral Argument, Jan. 4, 2007, 48 pages.

Smith & Nephew, Inc. v. Arthrex, Inc., Civil No. CV 04-0029 MO, Smith & Nephew's Response to Arthrex's Markman Brief, Jan. 5, 2007, 53 pages.

Smith & Nephew, Inc. v. Arthrex, Inc., Civil No. CV 04-0029 MO, Smith & Nephew's Opposition to Arthrex's Motion for Summary Judgment of Invalidity Over Prior Art, Jan. 5, 2007 (document dated 2006), 19 pages.

Smith & Nephew, Inc. v. Arthrex, Inc., Civil No. CV 04-0029 MO, Smith & Nephew's Opposition to Arthrex's Motion for summary Judgment of Invalidity for Double Patenting, Jan. 5, 2007, 19 pages.

Smith & Nephew, Inc. v. Arthrex, Inc., Civil No. CV 04-0029 MO, Supplemental Omnibus Declaration of Brenna K. Legaard in Support of Plaintiff's Response to Defendant's Markman Brief and Opposition to Defendant's Motions for Summary Judgment, 6 pages, with Exhibits 81-94, 96, 97 and 99-102, and 112, Jan. 5, 2007.

Smith & Nephew, Inc. v. Arthrex, Inc., Case No. CV 04-0029 MO, Arthrex, Inc.'s Response to Smith & Nephew's Opening Claim Construction Brief, Jan. 5, 2007, 41 pages.

Smith & Nephew, Inc. v. Arthrex, Inc., Case No. CV 04-0029 MO, Arthrex, Inc.'s Memorandum in Opposition to Smith and Nephew's Motion for Summary Judgment, pp. 1 and 11-61, Jan. 5, 2007, 51 pages (Confidential Material Redacted).

Smith & Nephew, Inc. v. Arthrex, Inc., Case No. CV 04-0029 MO, Declaration of Anthony P. Cho in Support of Arthrex, Inc.'s Response in Opposition to Smith & Nephew's Opening Claim Construction and Summary Judgment Briefs, 5 pages, with Exhibits A-W, Jan. 5, 2007.

Smith & Nephew, Inc. v. Arthrex, Inc., Civil No. CV 04-0029 MO, Smith & Nephew's Reply Brief in Support of its Motion for Summary Judgment, Jan. 19, 2007, 57 pages (Confidential Material Redacted).

Smith & Nephew, Inc. v. Arthrex, Inc., Civil No. CV 04-0029 MO, Smith & Nephew's Reply to Arthrex's Response to Smith & Nephew's Opening Claim Construction Brief, Jan. 19, 2007, 47 pages.

Smith & Nephew, Inc. v. Arthrex, Inc., Civil No. CV 04-0029 MO, Second Supplemental Omnibus Declaration of Brenna K. Legaard in Support of Smith & Nephew's Claim Construction and Summary Judgment Reply Briefs, 2 pages, with Exhibits 117-120, Jan. 19, 2007 (Confidential Material Redacted).

Smith & Nephew, Inc. v. Arthrex, Inc., Case No. CV 04-0029 MO, Arthrex, Inc.'s Reply to Smith & Nephew's Opening Claim Construction Brief, Jan. 19, 2007, 33 pages.

Smith & Nephew, Inc. v. Arthrex, Inc., Case No. CV 04-0029 MO, Arthrex, Inc.'s Reply to Smith & Nephew's Opposition to Arthrex's Motion for Summary Judgment of Invalidity for Double Patenting, Jan. 19, 2007, 15 pages.

Smith & Nephew, Inc. v. Arthrex, Inc., Case No. CV 04-0029 MO, Arthrex, Inc.'s Reply Brief in Support of its Motion for Summary Judgment of Invalidity Based upon Prior Art, Jan. 19, 2007, 12 pages.

Smith & Nephew, Inc. v. Arthrex, Inc., Case No. CV 04-0029 MO, Declaration in Support of Anthony P. Cho in Support of Arthrex, Inc.'s Reply to Opposition to Arthrex's Motion for Summary Judgment of Invalidity for Double Patenting, 2 pages, with Exhibits A-B, Jan. 19, 2007.

Smith & Nephew, Inc. v. Arthrex, Inc., Case No. CV 04-0029 MO, Markman Hearing Transcript of Proceedings Before the Honorable Michael W. Mosman United States District Court Judge, Feb. 26, 2007, 140 pages.

Smith & Nephew, Inc. v. Arthrex, Inc., Civil No. CV 04-0029 MO, Minutes of Proceedings, Feb. 27, 2007, 2 pages.

Smith & Nephew, Inc. v. Arthrex, Inc., Civil No. CV 04-0029 MO, Order, Mar. 1, 2007, 2 pages.

Smith & Nephew, Inc. v. Arthrex, Inc., Civil No. CV 04-0029 MO, Opinion Re: Claim Construction Issue Preclusion, Apr. 12, 2007, 8 pages.

Smith & Nephew, Inc. v. Arthrex, Inc., Civil No. CV 04-0029 MO, Opinion & Order Re: Summary Judgment, May 17, 2007, 25 pages.

Hayhurst, U.S. Appl. No. 11/292,385, Protest Under 37 CFR 1.291 of Reissue Patent Application, 33 pages, with Exhibits E-G, Apr. 20, 2007.

Smith & Nephew, Inc. v. Arthrex, Inc., Civil No. CV04-0029ST, Defendant's Supplemental Response to Plaintiff's First Set of Interrogatories, Jan. 20, 2006, 41 pages.

Smith & Nephew, Inc. v. Arthrex, Inc., Case No. CV04-0029ST, Expert Report of Dr. Wayne Burkhead, May 17, 2006, 27 pages.

Smith & Nephew, Inc. v. Arthrex, Inc., Case No. CV04-0029ST, Expert Report of Mr. David Carlson, May 19, 2006, 27 pages.

Smith & Nephew, Inc. v. Arthrex, Inc., Case No. CV04-0029ST, Expert Report of Dr. Allan Tencer, 41 pages.

- Smith & Nephew, Inc. v. Ethicon, Inc.*, Case No. CV98-76HU, Deposition of John O. Hayhurst, M.D., Oct. 9, 1998, 14 pages.
- Smith & Nephew, Inc. v. Ethicon, Inc.*, Smith & Nephew's Summary of Proposed Testimony for Markman Hearing, Sep. 20, 1998, 8 pages.
- Smith & Nephew, Inc. v. Arthrex*, Expert Rebuttal Report of Lisa A. Pruitt, Ph.D., Jul. 20, 2006, 35 pages.
- Smith & Nephew, Inc. v. Arthrex, Inc.*, Rebuttal Expert Report of David Randall Diduch, M.D., M.S., Jul. 21, 2006, 114 pages.
- Smith & Nephew, Inc. v. Arthrex, Inc.*, Rebuttal Expert Report of Wilson C. Hayes, Ph.D. Regarding the Issues of Validity, Jul. 21, 2006, 101 pages.
- Clancy, Jr. et al., "Anterior Cruciate Ligament Reconstruction using One-Third of the Patellar Ligament, Augmented by Extra-Articular Tendon Transfers", *The Journal of Bone and Joint Surgery*, 1982, pp. 352-359.
- Furnas et al., "A Teflon Toggle for Fastening Soft Tissue to Bone", *British Journal of Plastic Surgery*, 1976, pp. 104-105.
- Broström, "Sprained Ankles", *Acta Chir. Scand.*, vol. 132, 1966, pp. 551-565.
- Gibson et al., "Bankart Repairs Utilizing the Mitek Anchor System", 2 pages.
- Perthes, "Über Operationen bei habitueller Schulterluxation", *Deutsche Zeitschrift für Chirurgie*, vol. 85, 1906, pp. 199-227, with translation.
- "Medizinische Gesellschaft zu Leipzig: Offzielles Protokoll", *Muenchener Medizinische Wochenschrift*, Mar. 1905, pp. 481-482, with translation.
- Perthes, "Über Ergebnisse der Operationene bei habitueller Schulterluxation, mit besonderere Berücksichtigung unseres Verfaahrens", *Chir. Univ.-Klinik Tubingen*, Jul. 25, 1925, pp. 1-24, with translation.
- McLaughlin, "Repair of Major Tendon Ruptures by Buried Removable Suture", *American Journal of Surgery*, Nov. 1947, pp. 758-764.
- Augustine et al., "Boat-Nail Fixation of Tendons and Ligaments to Cancellous Bone", *Journal of Bone and Joint Surgery*, vol. 38-A, No. 5, Oct. 1956, pp. 1156-1158.
- Du Toit et al., "Recurrent Dislocation of the Shoulder", *Journal of Bone and Joint Surgery*, vol. 38-A, No. 1, Jan. 1956, pp. 1-12.
- Augustine, "The Unstable Knee", *American Journal of Surgery*, vol. 92, Sep. 1956, pp. 380-388.
- Perthes, "On therapy for habitual shoulder luxation", *Leipzig Medical Society*, 1905, 5 pages.
- Smith & Nephew, Inc. v. Ethicon, Inc.*, Civil No. CV98-76-MA, Declaration of Vicki Margolis in Support of Ethicon's Motion for Summary Judgment, Oct. 15, 1999, 800 pages. (Confidential Material Redacted).
- Smith & Nephew, Inc. v. Mitek Surgical Products, Inc.*, Civil No. CV 98-76 HA, Plaintiffs' Claim Infringement Chart, May 12, 1998, 11 pages.
- Smith & Nephew, Inc. v. Ethicon, Inc.*, Civil No. CV98-76HU, Defendant's Claim Construction Chart, Jul. 2, 1998, 33 pages.
- Smith & Nephew, Inc. v. Ethicon, Inc.*, Civil No. CV 98-76 HU, Smith & Nephew's Claim Interpretation Chart, Aug. 3, 1998, 11 pages.
- Smith & Nephew, Inc. v. Ethicon, Inc.*, Civil No. CV 98-76 HA, Ethicon's Supplemental Responses to Plaintiffs' First Set of Interrogatories (Interrogatory No. 6), Aug. 12, 1998, 7 pages.
- Smith & Nephew, Inc. v. Ethicon, Inc.*, Civil No. CV 98-76 HA, Ethicon's Supplemental Response to Plaintiffs' First Set of Interrogatories (Interrogatory No. 5), Aug. 12, 1998, 16 pages.
- Smith & Nephew, Inc. v. Ethicon, Inc.*, Civil No. CV98-76HU, Ethicon's Claim Construction Memorandum, Aug. 21, 1998, 33 pages.
- Smith & Nephew, Inc. v. Ethicon, Inc.*, Civil No. CV-98-76-HA, Smith & Nephew's Memorandum of Law Regarding Ethicon's Claim Interpretation Errors, Aug. 1998, 9 pages.
- Smith & Nephew, Inc. v. Ethicon, Inc.*, Civil Action No. CV-98-76-HU, Smith & Nephew's "Markman" Brief, Sep. 4, 1998, 31 pages.
- Smith & Nephew, Inc. v. Ethicon, Inc.*, Civil Action No. CV-98-76-HU, Declaration of Mark J. Herbert, Sep. 4, 1998, 87 pages.
- Smith & Nephew, Inc. v. Ethicon, Inc.*, Civil No. CV98-76HU, Ethicon, Inc.'s Claim Construction Brief, Sep. 4, 1998, 41 pages.
- Smith & Nephew, Inc. v. Ethicon, Inc.*, Civil No. CV98-76HU, Declaration of Michael P. Leary, Esq. In Support of Defendant Ethicon, Inc.'s Claim Construction Brief, Sep. 2, 1998, 310 pages.
- Smith & Nephew, Inc. v. Ethicon, Inc.*, Civil No. CV98-76HU, Reply to Plaintiffs' Opposition to Ethicon's Motion for Summary Judgment of Invalidity, Feb. 2, 1999, 18 pages.
- Smith & Nephew, Inc. v. Ethicon, Inc.*, Civil No. CV98-76HU, Ethicon, Inc.'s Supplemental Memo on Claim Construction to Bring to the Court's Attention New Case Authority, Mar. 17, 1999, 4 pages.
- Smith & Nephew, Inc. v. Ethicon, Inc.*, Civil No. 98-76-HU, Findings and Recommendations, May 24, 1999, 10 pages.
- Smith & Nephew, Inc. v. Ethicon, Inc.*, Civil No. 98-76-HU, Amended Findings and Recommendations, Jun. 11, 1999, 10 pages.
- Smith & Nephew, Inc. v. Ethicon, Inc.*, Civil No. 98-76-HU, Order, Aug. 5, 1999, 3 pages.
- Smith & Nephew, Inc. v. Ethicon, Inc.*, Civil No. CV98-76-MA, Ethicon's Motion for Summary Judgment, Request for Oral Argument, Oct. 15, 1999, 3 pages. (Confidential Material Redacted).
- Smith & Nephew, Inc. v. Ethicon, Inc.*, Civil No. CV98-76-MA, Ethicon's Memorandum of Law in Support of its Motion for Summary Judgment, Request for Oral Argument, Oct. 15, 1999, 56 pages. (Confidential Material Redacted).
- Smith & Nephew, Inc. v. Ethicon, Inc.*, CV. No. 98-76-HU, Transcript of Markman Hearing Before the Honorable Dennis J. Hubel, Nov. 18, 1998, pp. 1-235.
- Smith & Nephew, Inc. v. Ethicon, Inc.*, Civil No. CV98-76HU, Memorandum in Support of Defendant Ethicon Inc's Motion for Summary Judgment of Unenforceability, Dec. 18, 1998, 22 pages.
- Smith & Nephew, Inc. v. Ethicon, Inc.*, Civil No. CV98-76HU, Concise Statement of Material Facts in Support of Defendant Ethicon Inc.'s Motion for Summary Judgment of Unenforceability, Dec. 18, 1998, 6 pages.
- Smith & Nephew, Inc. v. Ethicon, Inc.*, Civil No. CV98-76HU, Declaration of Michael P. Leary, Esq. in Support of Defendant Ethicon, Inc.'s Summary Judgment Motion of Unenforceability, Dec. 17, 1998, 89 pages.
- Smith & Nephew, Inc. v. Ethicon, Inc.*, Civil No. CV98-76HU, Ethicon Inc.'s Motion for Summary Judgment of Invalidity, Dec. 18, 1998.
- Smith & Nephew, Inc. v. Ethicon, Inc.*, Civil No. CV98-76HU, Memorandum in Support of Defendant Ethicon's Motion for Summary Judgment of Invalidity, Dec. 18, 1998, 18 pages.
- Smith & Nephew, Inc. v. Ethicon, Inc.*, Civil No. CV98-76HU, Errata to Ethicon's Memorandum in Support of Ethicon's Motion for Summary Judgment of Invalidity, Jan. 19, 1999, 5 pages.
- Smith & Nephew, Inc. v. Ethicon, Inc.*, Civil No. CV98-76HU, Concise Statement of Material Facts in Support of Defendant Ethicon Inc.'s Motion for Summary Judgment of Invalidity, Dec. 18, 1998, 6 pages.
- Smith & Nephew, Inc. v. Ethicon, Inc.*, Civil No. CV98-76HU, Declaration of Michael P. Leary, Esq. in Support of Defendant Ethicon, Inc.'s Summary Judgment Motion of Invalidity, Dec. 17, 1998, 165 pages.
- Smith & Nephew, Inc. v. Ethicon, Inc.*, Civil No. CV98-76HU, Declaration of Michael P. Leary in Support of the Reply to Plaintiffs' Opposition to Ethicon Motion for Summary Judgment of Invalidity, Feb. 1, 1999, 8 pages.
- Smith & Nephew, Inc. v. Ethicon, Inc.*, Civil Action No. CV-98-76-HU, Smith & Nephew's Opposition to Ethicon, Inc.'s Motion for Summary Judgment of Invalidity, Jan. 19, 1999, 36 pages.
- Smith & Nephew, Inc. v. Ethicon, Inc.*, Civil Action No. CV-98-76-HU, Smith & Nephew's Response to Ethicon's Concise Statement of Facts Regarding Ethicon's Motion for Summary Judgment of Invalidity, Jan. 19, 1999, 25 pages.
- Smith & Nephew, Inc. v. Ethicon, Inc.*, Civil Action No. CV-98-76-HU, Declaration of John M. Skenyon in Support of Smith & Nephew's Opposition to Ethicon's Summary Judgment Motion of Invalidity, Jan. 19, 1999, 42 pages.
- Smith & Nephew, Inc. v. Ethicon, Inc.*, Civil Action No. CV-98-76-HU, Smith & Nephew's Opposition to Ethicon's Motion for Summary Judgment of Unenforceability, Jan. 19, 1999, 8 pages.
- Smith & Nephew, Inc. v. Ethicon, Inc.*, Civil Action No. CV-98-76-HU, Smith & Nephew's Response to Ethicon's Separate Concise

- Statement of Facts Regarding Ethicon's Motion for Summary Judgment of Unenforceability, Jan. 19, 1999, 18 pages.
- Smith & Nephew, Inc. v. Ethicon, Inc.*, Civil No. CV98-76HU, Reply to Plaintiffs' Opposition to Ethicon's Motion for Summary Judgment of Unenforceability, Feb. 2, 1999, 7 pages.
- McLaughlin, Harrison, "Repair of Ruptures Through The Larger Tendons By Removable Staple Suture: A Preliminary Report", *Archives of Surgery*, 1946, pp. 547-556.
- McLaughlin, Harrison, "Repair of Major Tendon Ruptures By Buried Removable Suture", *American Journal of Surgery*, vol. 74, No. 5, Nov. 1947, pp. 758-764.
- Perthes, "Über Operationen bei habitueller Schulterluxation", *Deutsch Ztschr Chir*, 1906, pp. 199-227.
- Boyd, et al., "Recurrent Dislocation of the Shoulder", *The Journal of Bone and Joint Surgery*, vol. 47-A, No. 8, Dec. 1965, pp. 1514-1520.
- Sisk et al., "Management of Recurrent Anterior Dislocation of the Shoulder", *Clinical Orthopaedics and Related Research*, No. 103, Sep. 1974, pp. 150-156.
- Palmer et al., "Supracondylar Fracture of the Humerus in Children", *The Journal of Bone and Joint Surgery*, Vol. 60-, No. 5, Jul. 1978, pp. 653-656.
- Wright, "Dislocations", *Campbell's Operative Orthopaedics*, vol. 1, 6th edition, Chapter 4, 1980, pp. 418, 474-499.
- Goth et al., "Die operative Behandlung der ulnaren Seitenbandruptur des Daumengrundgelenkes", *Handchirurgie: Zeitschrift der Deutschsprachigen Arbeitsgemeinschaft für Handchirurgie*, 1979.
- Noyes, M.D. et al., "Intra-articular Cruciate Reconstruction: 1: Perspectives on Graft Strength, Vascularization, and Immediate Motion after Replacement", *Clinical Orthopaedics and Related Research*, No. 172, Jan.-Feb. 1983, pp. 71-77.
- Murphy et al., "Displaced Olecranon Fractures in Adults", *Clinical Orthopaedics and Related Research*, No. 224, Nov. 1987, pp. 210-214.
- Hendler, "A unitunnel technique for arthroscopic anterior cruciate ligament reconstruction", *Techniques In Orthopaedics*, vol. 2, No. 4, Jan. 1988, pp. 52-59.
- Downing, "A Simplification of Bankart's Capsulorrhaphy for Recurrent Dislocation of the Shoulder" *The Journal of Bone and Joint Surgery*, vol. 28, No. 2, Apr. 1946, pp. 250-252.
- Robertson et al., "Soft Tissue Fixation to Bone", *The American Journal of Sports Medicine*, vol. 14, No. 5, 1986, pp. 398-403.
- Ogilvie, "Recurrent Dislocation of the Shoulder", *British Medical Journal*, Mar. 9, 1946, p. 362.
- Swanson, "Silicone Rubber Implants for Replacement of Arthritic or Destroyed Joints in the Hand", *Surgical Clinics of North America*, vol. 48, No. 5, Oct. 1968, pp. 1113-1127.
- Nikolaou et al., "Anterior cruciate ligament allograft transplantation," *The American Journal of Sports Medicine*, vol. 14, No. 5, 1986, pp. 348-360.
- Jackson et al., "Freeze dried anterior cruciate ligament allografts", *The American Journal of Sports Medicine*, vol. 15, No. 4, 1987, pp. 295-302.
- Jackson et al., "Cruciate reconstruction using freeze dried anterior cruciate ligament allograft and a ligament augmentation device (LAD)", *The American Journal of Sports Medicine*, vol. 15, No. 6, 1987, pp. 528-538.
- Ward et al., "Tensile Strength Comparison of Dowel Plug Technique to Standard Techniques of Tendon-Bone Attachment", *The Official Journal of the American Orthopaedic Foot and Ankle Society*, vol. 8, No. 5, 1988, pp. 248-253.
- Magnuson, et al., "Recurrent Dislocation of the Shoulder", *The Journal A.M.A.*, vol. 123, No. 14, 1943, pp. 889-892.
- Gomes et al., "Anterior cruciate ligament reconstruction with a loop or double thickness of semitendinosus tendon", *The American Journal of Sports Medicine*, vol. 12, No. 3, 1984, pp. 199-203.
- May, "A Modified Bristow Operation for Anterior Recurrent Dislocation of the Shoulder", *The Journal of Bone and Joint Surgery*, vol. 52-A, No. 5, 1970, pp. 1010-1016.
- Artz et al., "A Major Complication of the Modified Bristow Procedure for Recurrent Dislocation of the Shoulder", *The Journal of Bone and Joint Surgery*, vol. 54-A., No. 6, 1972, pp. 1293-1296.
- Ormandy, "Olecranon Screw for Skeletal Traction of the Humerus", *The American Journal of Surgery*, vol. 127, 1974, pp. 615-616.
- Lombardo et al., "The Modified Bristow Procedure for Recurrent Dislocation of the Shoulder", vol. 58-A, No. 2, 1976, pp. 256-261.
- Hill et al., "The modified Bristow-Helfet procedure for recurrent anterior shoulder subluxations and dislocations", *The American Journal of Sports Medicine*, vol. 9, No. 5, 1981, pp. 283-287.
- Lambert, "Vascularized Patellar Tendon Graft with Rigid Internal Fixation for Anterior Cruciate Ligament Insufficiency", *Clinical Orthopaedics and Related Research*, No. 172, 1983, pp. 85-89.
- Helfet, "Coracoid Transplantation For Recurring dislocation Of The Shoulder", *The Journal of Bone and Joint Surgery*, vol. 40-B, No. 2, 1958, pp. 198-202.
- Smith & Nephew, Inc. v. Ethicon, Inc.*, 276 F.3d 1304 (Fed. Cir. 2001), 15 pages.
- Smith & Nephew, Inc. v. Ethicon, Inc.*, Briefs for Plaintiffs-Appellants, CAFC Appeal Nos. 00-1160, -127, Apr. 27, 2000, 124 pages.
- Smith & Nephew, Inc. v. Ethicon, Inc.*, Brief for Defendant-Cross Appellant, CAFC Appeal Nos. 00-1160, Jul. 19, 2000, 73 pages.
- Smith & Nephew, Inc. v. Ethicon, Inc.*, Reply Brief for Plaintiffs-Appellants, CAFC Appeal No. 00-1160, Aug. 2, 2000, 32 pages.
- Smith & Nephew, Inc. v. Ethicon, Inc.*, Defendant-Appellee Ethicon Inc.'s Petition for Rehearing En Banc, CAFC Appeal No. 00-1160, Jan. 9, 2002, 52 pages.
- Smith & Nephew, Inc. v. Ethicon, Inc.*, Plaintiffs-Appellants' Response to Defendant-Appellee Ethicon, Inc.'s Petition for Rehearing En Banc, CAFC Appeal No. 00-1160, Jan. 28, 2002, 23 pages.
- Smith & Nephew, Inc. v. Arthrex, Inc.*, Declaration of Steven Susser in Support of Arthrex Inc.'s Renewed Motion for Judgment as a Matter of Law, or in the Alternative, for a New Trial, USDC CV04-0029ST, Exhibits 1-6, and 10-13, Jul. 28, 2008, 121 pages, confidential material redacted.
- Smith & Nephew, Inc. v. Arthrex, Inc.*, Memorandum in Support of Arthrex, Inc.'s Renewed Motion for Judgment as a Matter of Law, or in the Alternative, for a New Trial, USDC CV04-0029-MO, Jul. 28, 2008, 32 pages, confidential material redacted.
- Smith & Nephew, Inc. v. Arthrex, Inc.*, Defendant's Second Amended Response to Plaintiffs' First Set of Interrogatories, USDC CV04-0029ST, Apr. 29, 2006, 8 pages.
- Smith & Nephew, Inc. v. Arthrex, Inc.*, Plaintiffs' Opposition to Arthrex's Motion for Stay of Judicial Proceedings Pending Reexamination of U.S. Patent No. 5,601,557, USDC CV04-0029-MO, Jul. 22, 2008, 15 pages.
- Smith & Nephew, Inc. v. Arthrex, Inc.*, Memorandum in Support of Arthrex, Inc.'s Motion to Stay Judicial Proceedings Pending Reexamination Proceeding of U.S. Patent No. 5,601,557, USDC CV04-0029-MO, Jul. 11, 2008, 8 pages.
- Smith & Nephew, Inc. v. Arthrex, Inc.*, Motion to Stay Judicial Proceedings Pending Reexamination Proceeding of U.S. Patent No. 5,601,557, USDC CV04-0029-ST, Jul. 11, 2008, 2 pages.
- Smith & Nephew, Inc. v. Arthrex, Inc.*, Complaint for Patent Infringement, USDC CV08-714-PK, Jun. 11, 2008, 4 pages.
- Smith & Nephew, Inc. v. Arthrex, Inc.*, Jury Verdict, USDC CV04-029-MO, Jun. 11, 2008, 3 pages.
- Smith & Nephew, Inc. v. Ethicon, Inc.*, Stipulated Consent Judgment, USDC CV-98-76-MA, Dec. 11, 2002, 3 pages.
- Smith & Nephew, Inc. v. Arthrex, Inc.*, CV04-0029ST, Confidential Deposition of John O. Hayhurst, MD, pp. 1, 10-21, 50-53, 66-101, Errata Sheet, Exhibit 15, Nov. 4, 2004, 16 pages.
- Ex Parte Reexamination Communication in U.S. Appl. No. 90/009,307, mailed Sep. 24, 2009, 10 pages.
- Fish & Richardson P.C., Amendment in Reply to Action dated Sep. 24, 2009, in U.S. Appl. No. 90/009,307, filed Oct. 22, 2008, 24 pages.
- U.S. Court of Appeals for the Federal Circuit, *Smith & Nephew, Inc. and John O. Hayhurst v. Arthrex, Inc.*, Case No. 2009-1091,-1192, Disposition, dated Dec. 2, 2009, 9 pages.
- Smith & Nephew, Inc. v. Ethicon, Inc.*, Civil No. CV98-76-MA, Declaration of Edward S. Grood, Ph.D. In Support of Ethicon's Motion for Summary Judgment, Oct. 18, 1999, 51 pages.
- Smith & Nephew, Inc. v. Ethicon, Inc.*, Civil Action No. CV-98-76-MA, *Smith & Nephew's* Opposition to Ethicon's Motion for Summary Judgment, Oct. 29, 1999, 49 pages. (Confidential Material Redacted).
- Smith & Nephew, Inc. v. Ethicon, Inc.*, Civil Action No. CV-98-76-MA, *Smith & Nephew's* Revised Response to Ethicon's Five Sepa-

rate Concise Statements of Facts Regarding Ethicon's Motion for Summary Judgment, Oct. 29, 1999, 51 pages. (Confidential Material Redacted).

Smith & Nephew, Inc. v. Ethicon, Inc., Civil No. 98-76-MA, Opinion and Order, Dec. 17, 1999, 18 pages.

Smith & Nephew, Inc. v. Ethicon, Inc., Civil No. 98-76-MA, Amended Judgment, Feb. 16, 2000, 5 pages.

Smith & Nephew, Inc. v. Ethicon, Inc., Civil No. 98-76-MA, Order, Feb. 16, 2000, 4 pages.

Smith & Nephew, Inc. v. Ethicon, Inc., Civil Case No. 98-CV-76-MA, Judgment, Dec. 12, 2001, 29 pages.

Smith & Nephew, Inc. v. Biomet, Inc., Case No. 3:05-CV-611-JE, Declaration of Laura Caldera Taylor in Support of Defendants Biomet, Inc.'s and Arthrotek, Inc.'s Memorandum in Response to Plaintiffs' Motion for Preliminary Injunction, Aug. 5, 2005, 174 pages. (Confidential Material Redacted).

Smith & Nephew, Inc. v. Biomet, Inc. and Arthrotek, Inc., Case No., CV05-611-JE, Plaintiffs' Claim Chart in Support of Motion for Preliminary Injunction, 8 pages.

Smith & Nephew, Inc. v. Biomet, Inc., Case No. CV05-611, Defendants Biomet, Inc.'s and Arthrotek, Inc.'s Memorandum in Response

to Plaintiffs' Motion for Preliminary Injunction, Aug. 5, 2005, 37 pages. (Confidential Material Redacted).

Smith & Nephew, Inc. v. Biomet, Inc., Case No. CV05-611-JE, Plaintiffs' Corrected Reply Brief in Support of Their Motion for Preliminary Injunction, Aug. 18, 2005 39 pages. (Confidential Material Redacted).

Smith & Nephew, Inc. v. Biomet, Inc., Case No. 05-611-K1, Opinion and Order, Nov. 21, 2005, 35 pages.

Smith & Nephew, Inc. v. Arthrotek, Inc., Case No. CV04-0029ST, Confidential Deposition of John O. Hayhurst, M.D., Nov. 4, 2004, 16 pages.

Smith & Nephew, Inc. v. Arthrotek, Inc., Case No. CV04-0029ST, Defendant's Response to Plaintiffs' First Set of Interrogatories, 4 pages.

Smith & Nephew, Inc. v. Arthrotek, Inc., Case No. CV04-0029ST, Smith & Nephew v. Arthrotek Claim Construction Chart, 3 pages.

Smith & Nephew, Inc. v. Arthrotek, Inc., Case No. CV04-0029ST, Arthrotek's Proposed Claim Construction '557 patent, 3 pages.

* cited by examiner

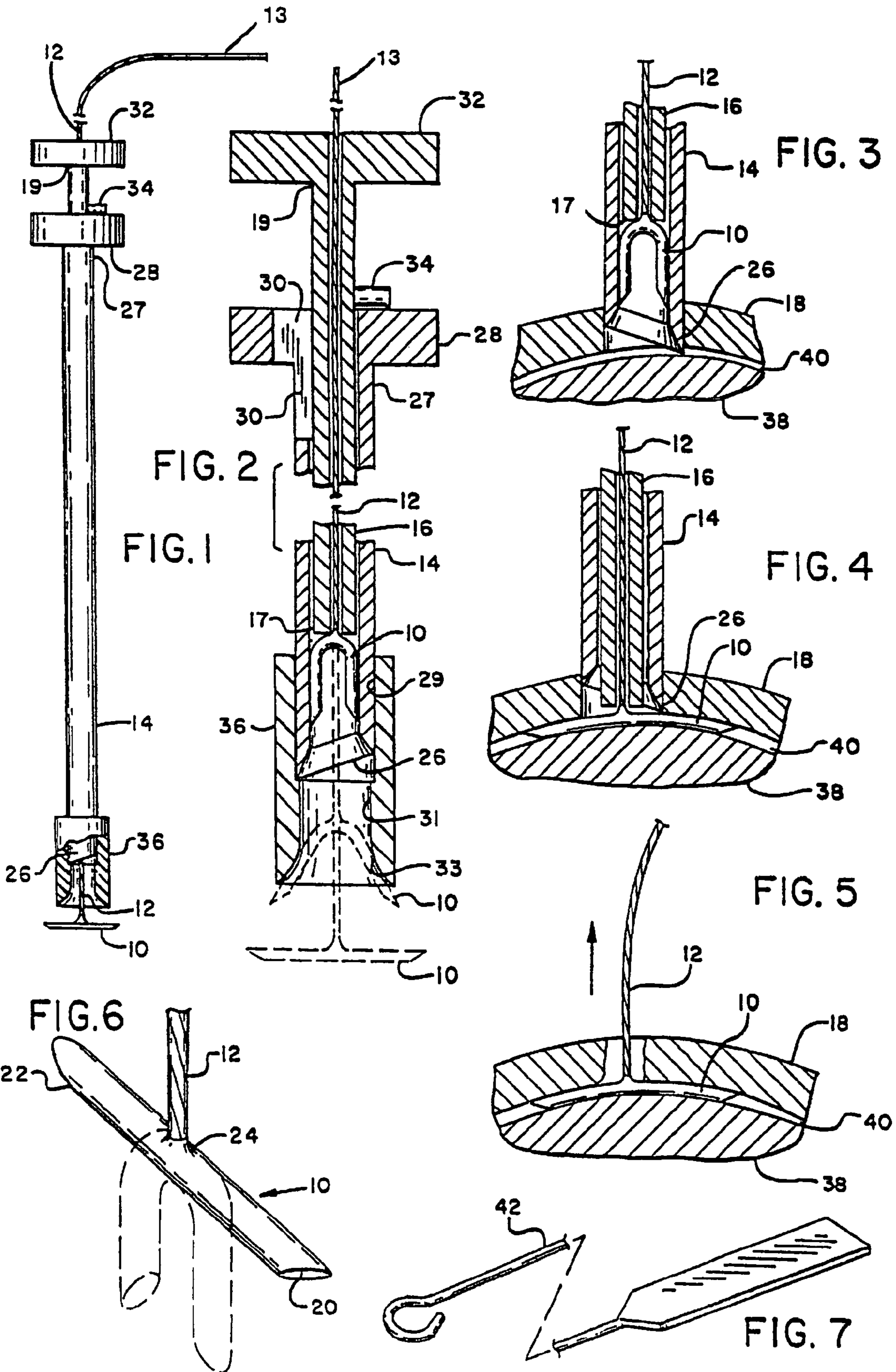

FIG. 8

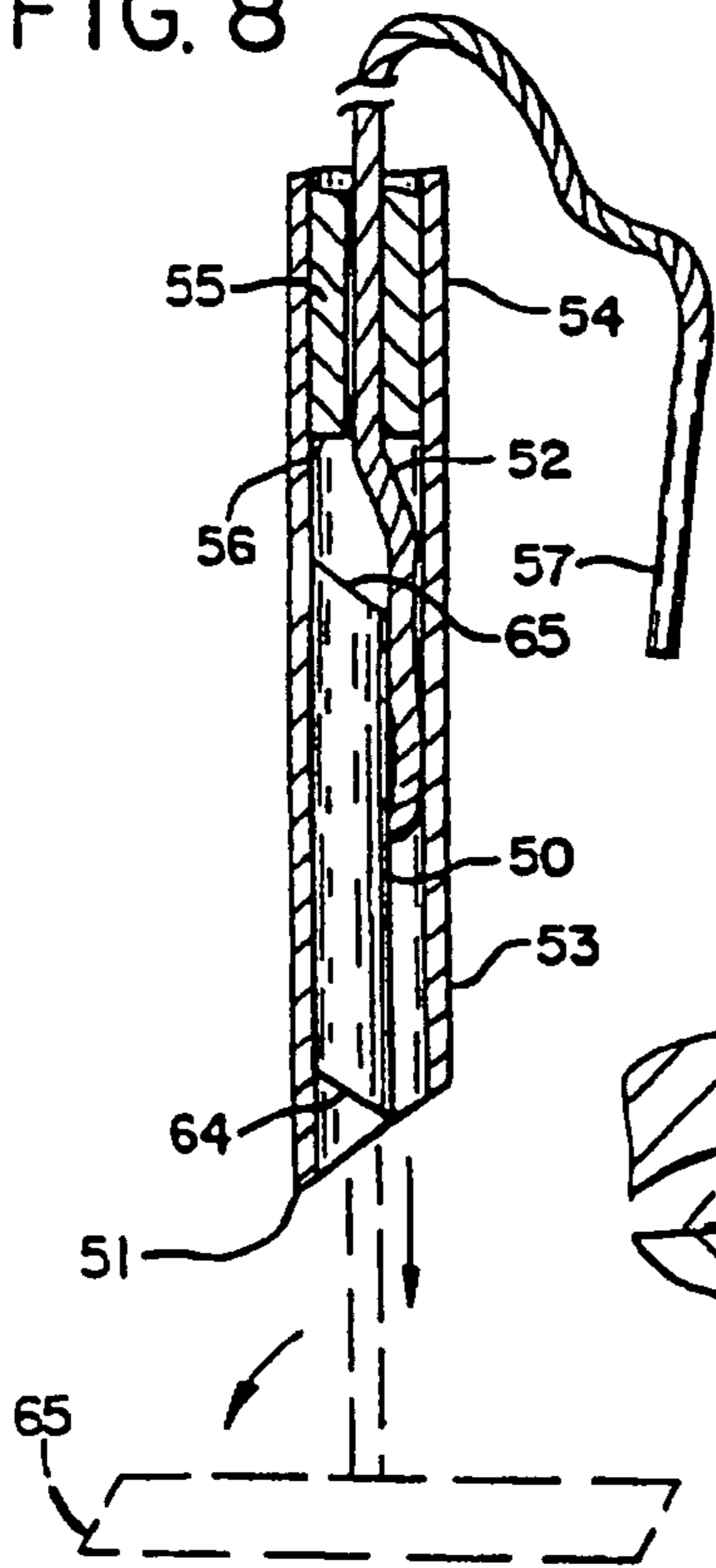

FIG. 9

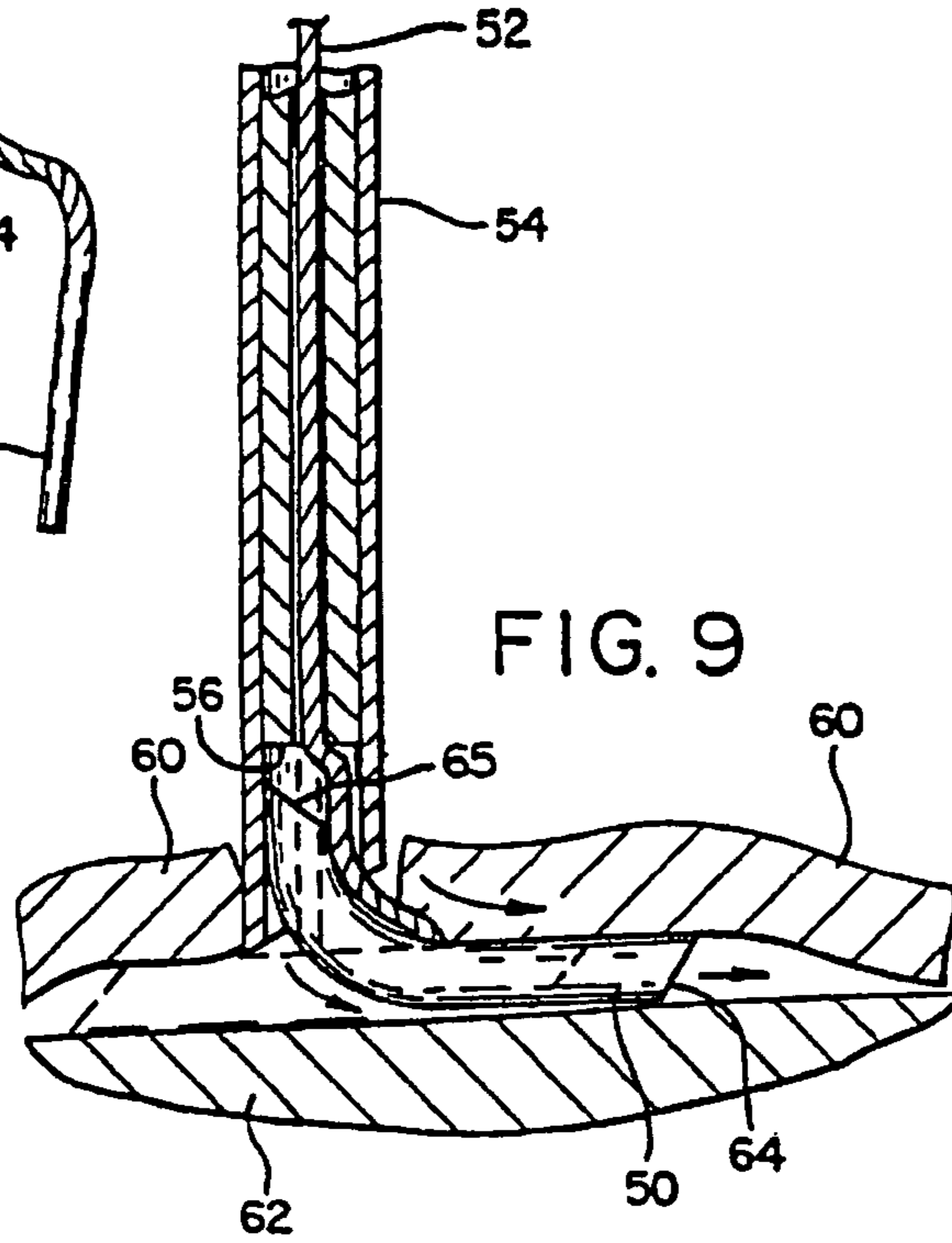

FIG. 12

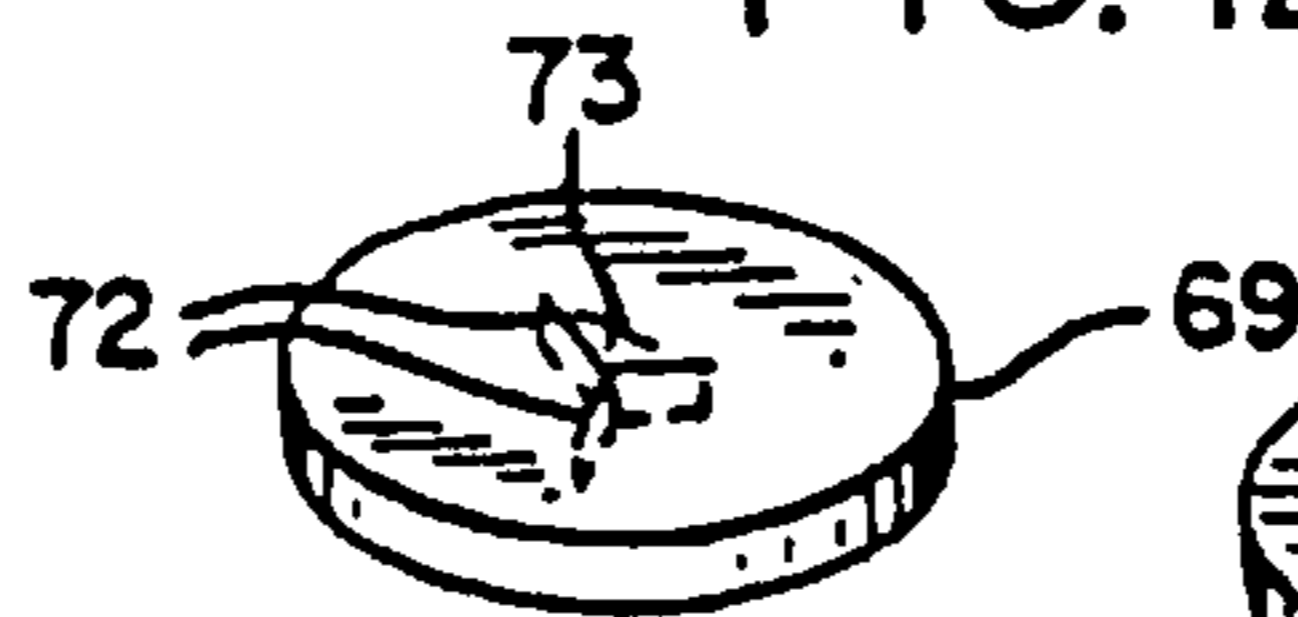

FIG. 11

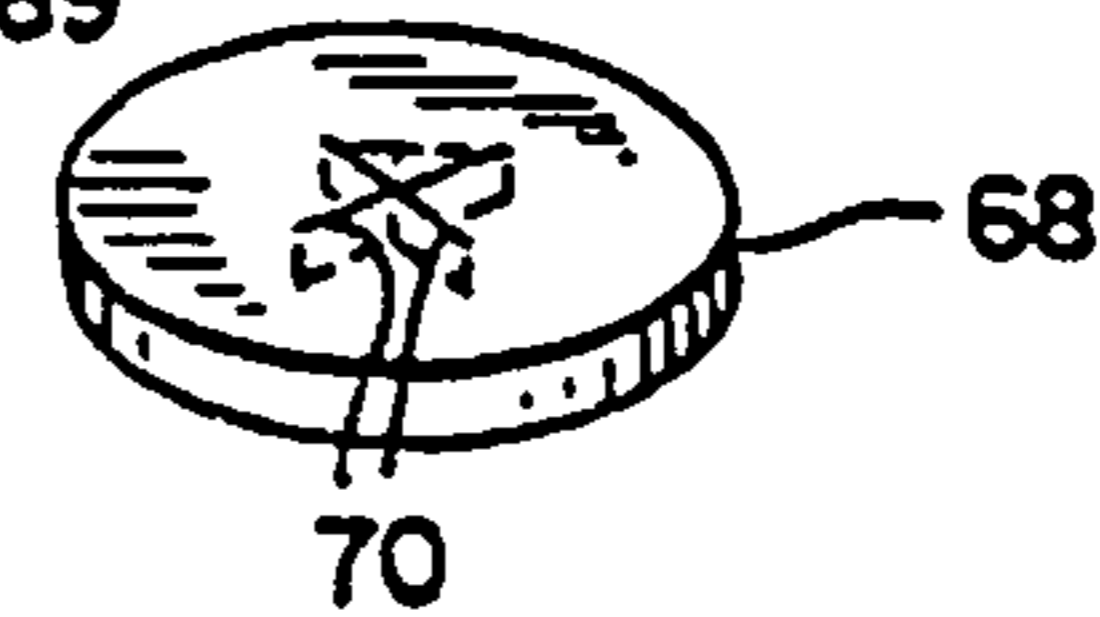

FIG. 10

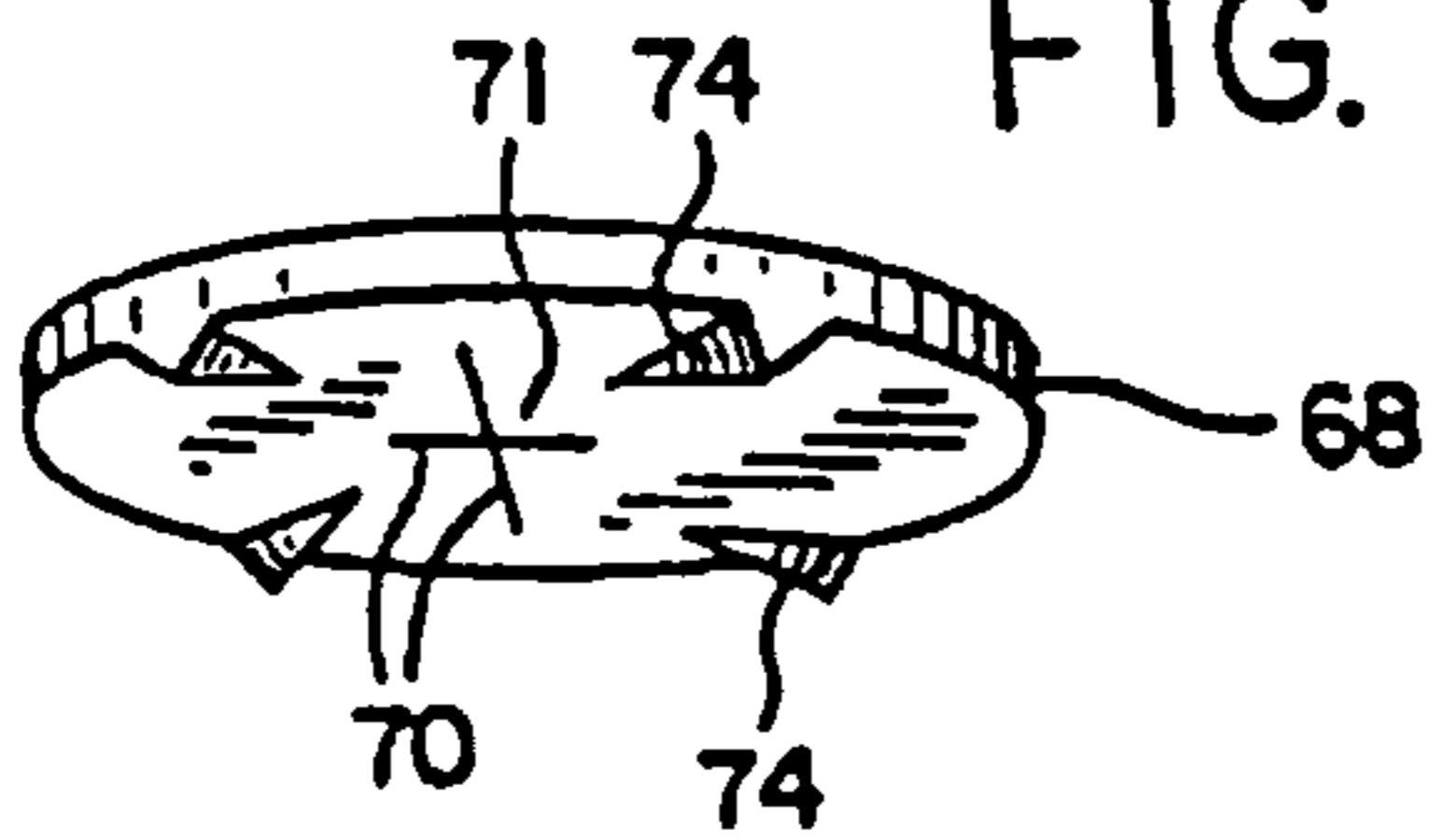

FIG. 13

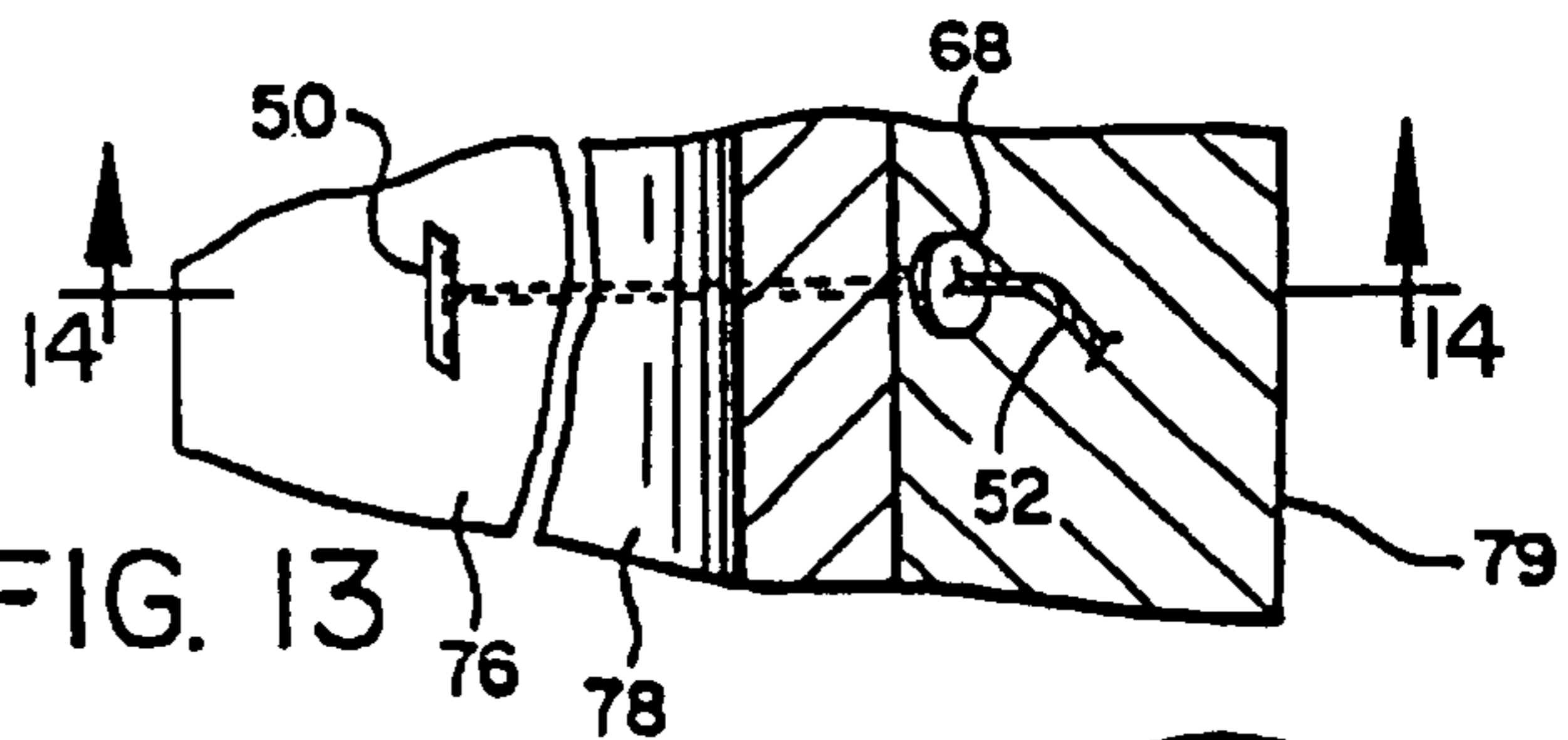
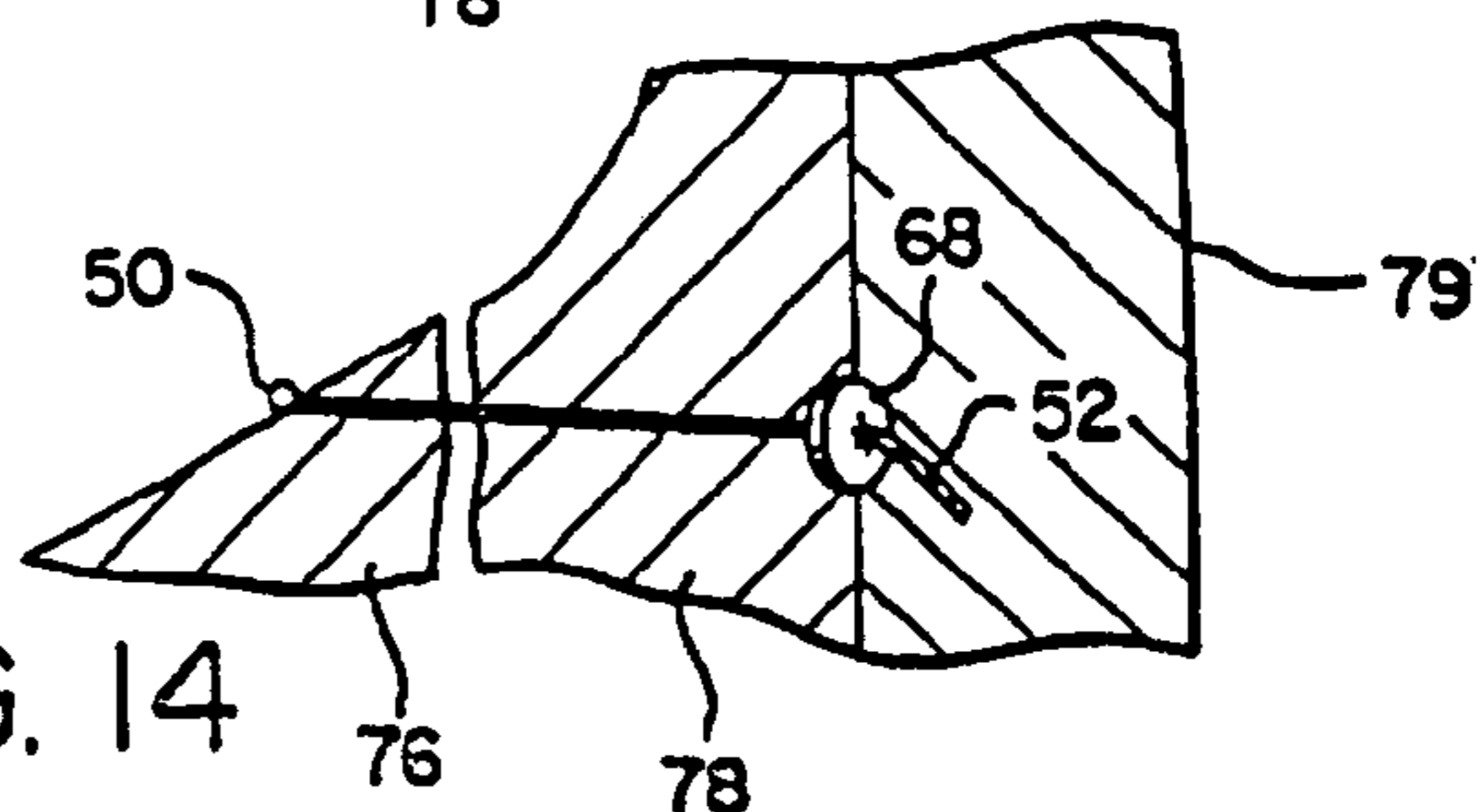
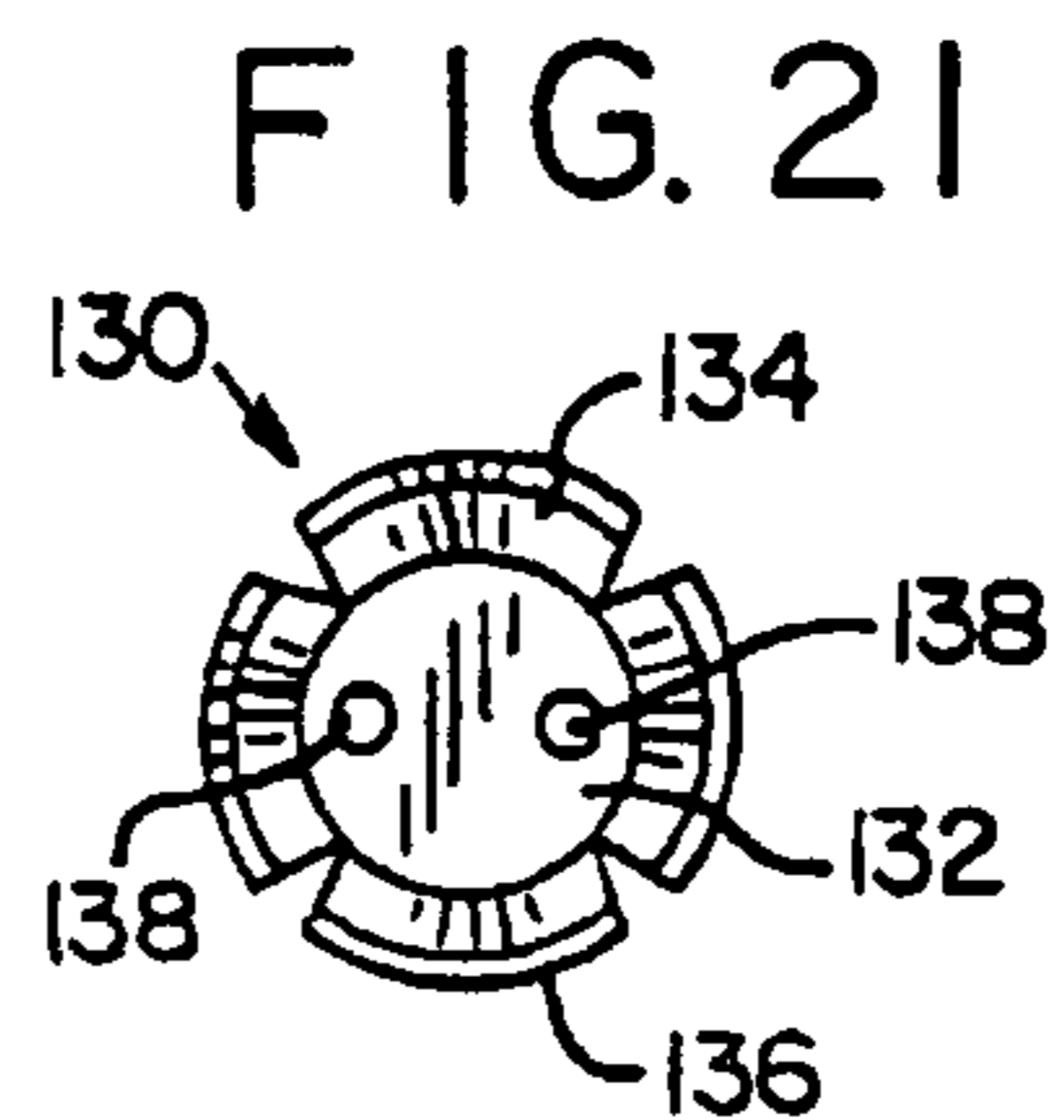
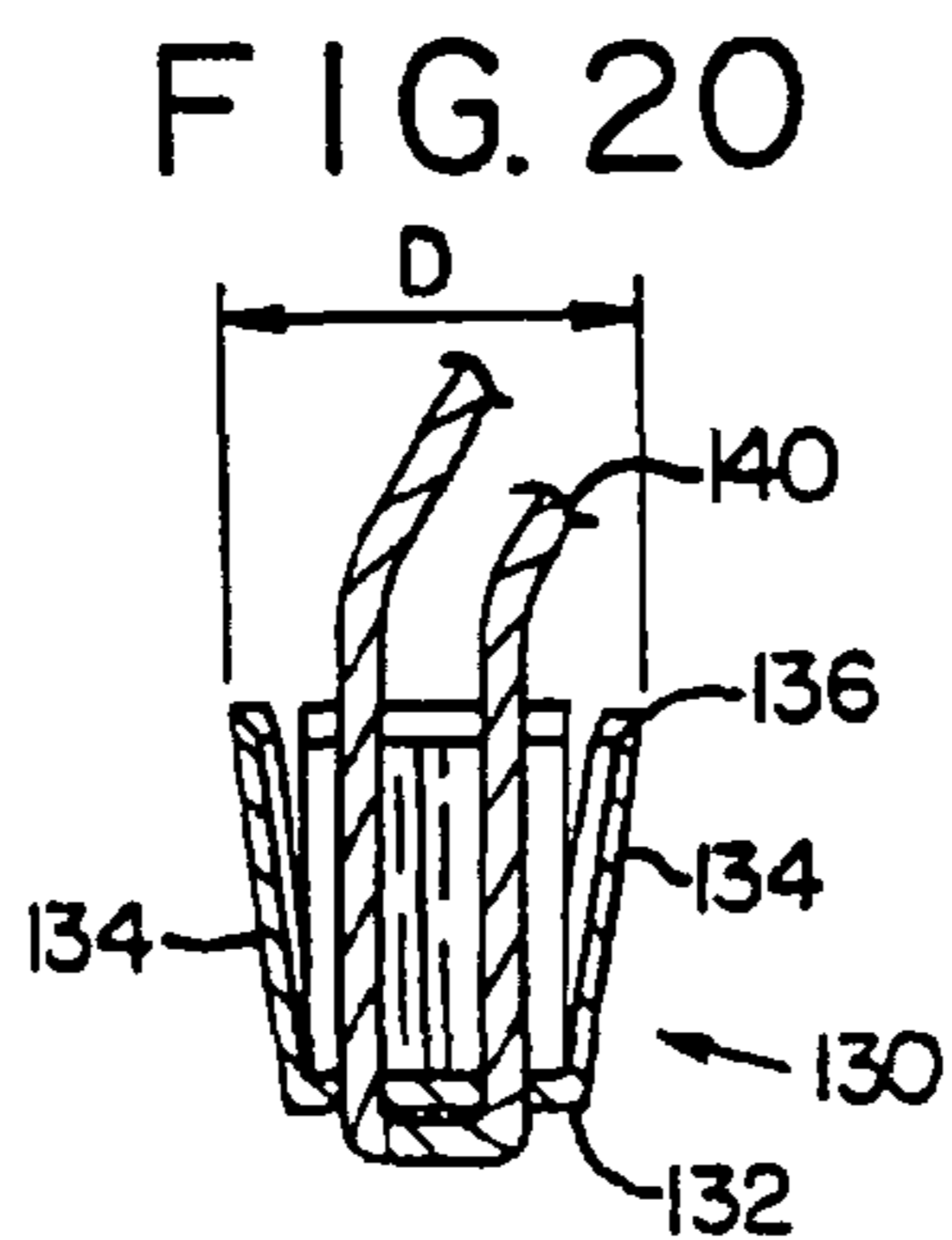
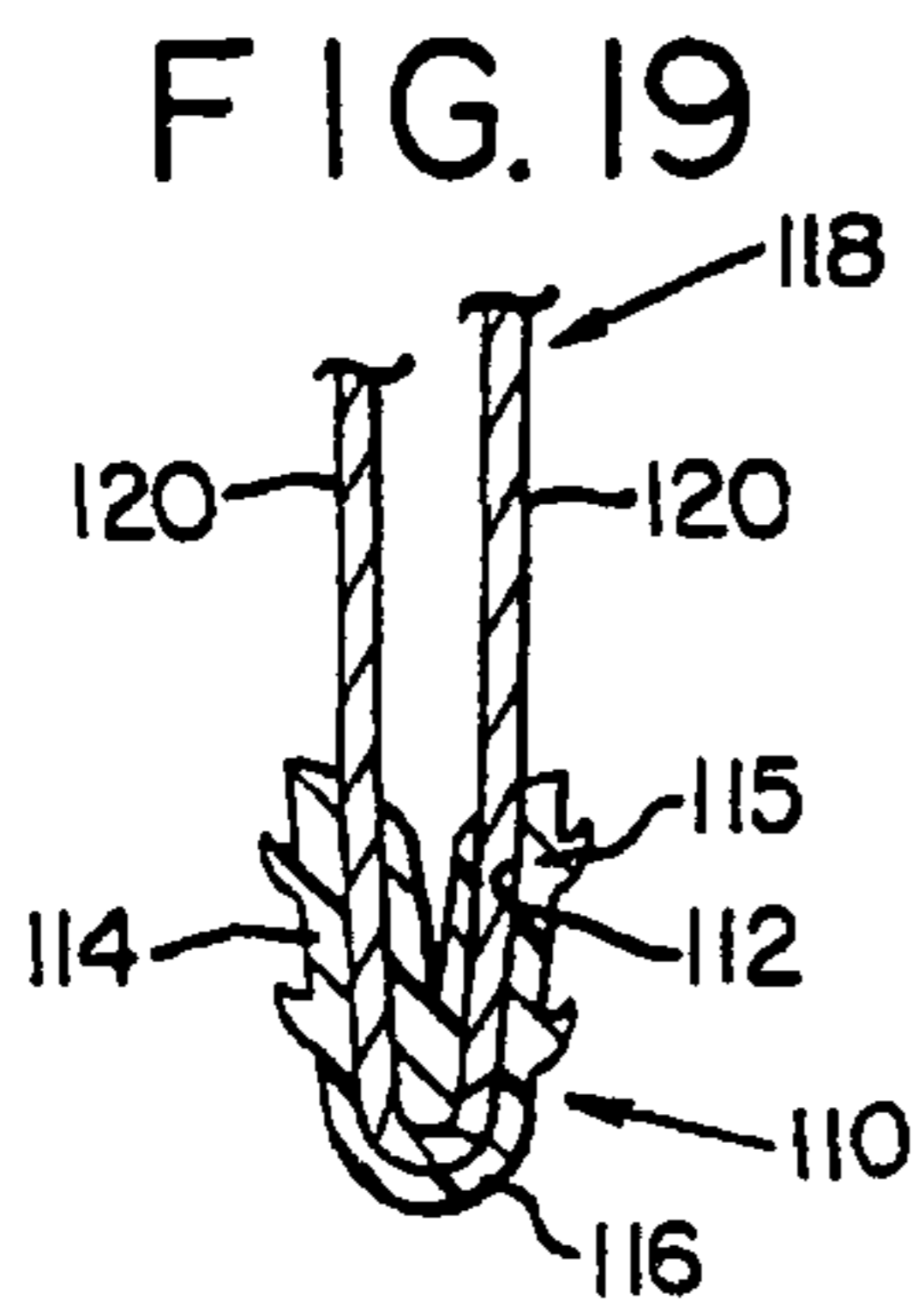
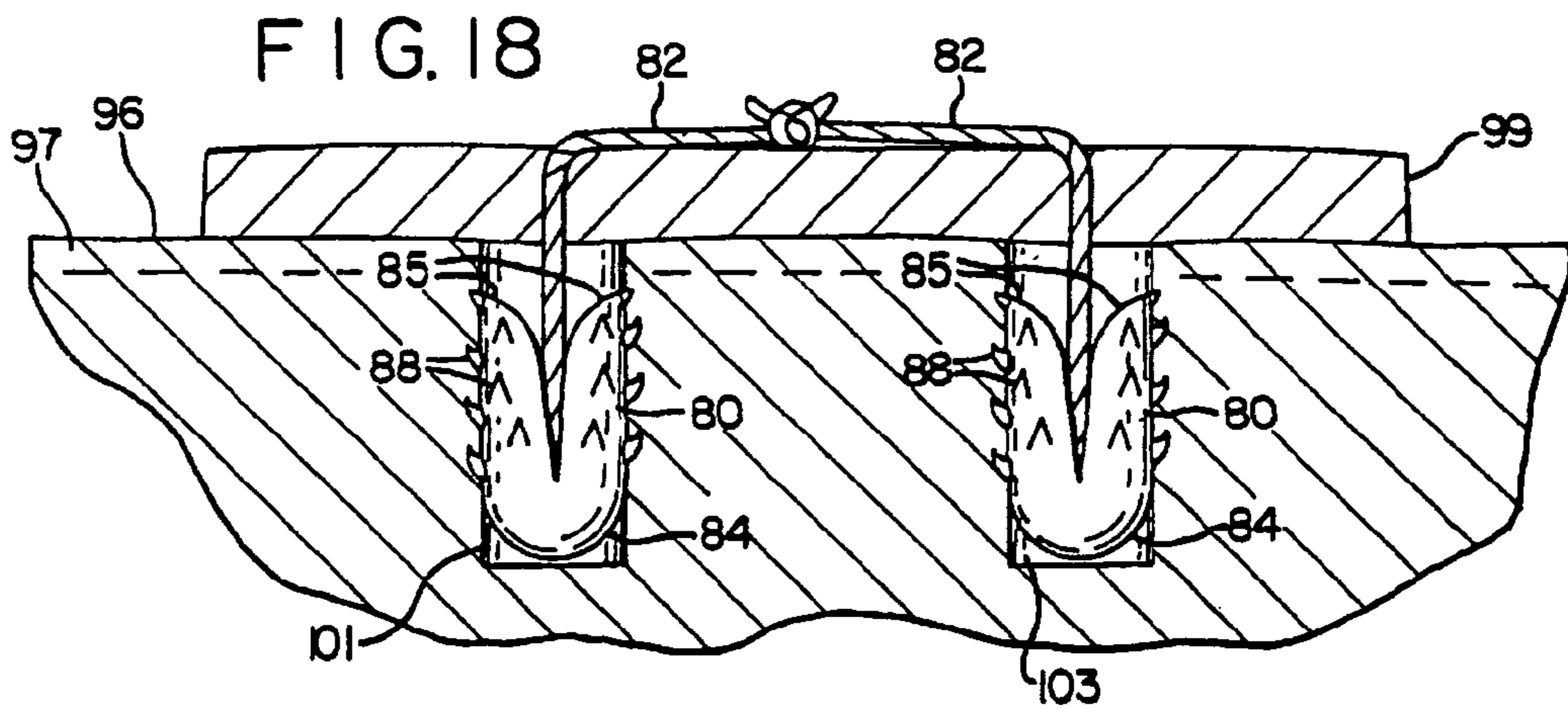
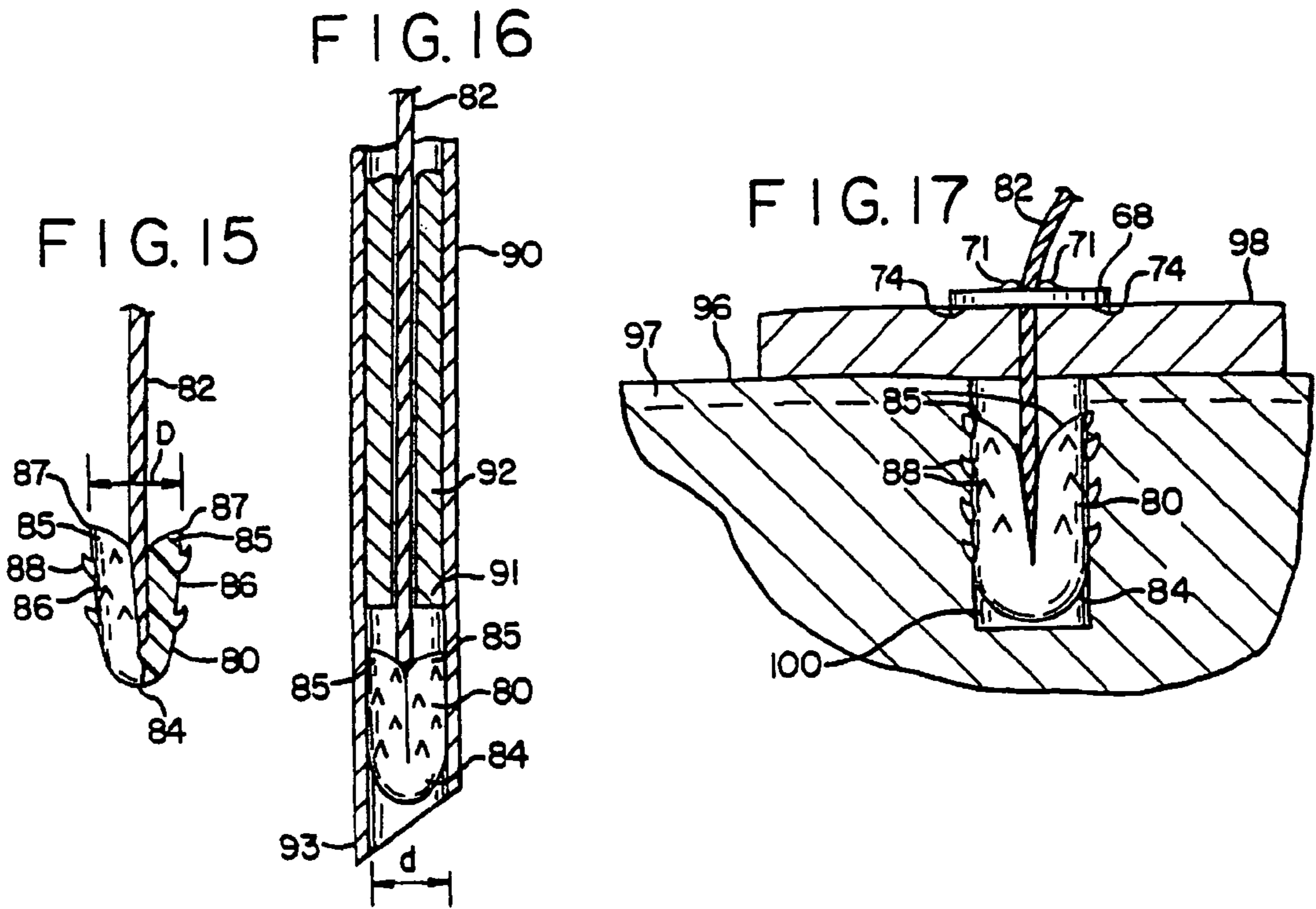

FIG. 14





TISSUE MANIPULATION

Matter enclosed in heavy brackets [] appears in the original patent but forms no part of this reissue specification; matter printed in italics indicates the additions made by reissue.

This application is a continuation of application Ser. No. 08/048,922, filed Apr. 15, 1993, now U.S. Pat. Ser. No. 5,417,691, hereby incorporated by reference, which is a continuation of application Ser. No. 07/192,813, filed Apr. 20, 1988, abandoned, which is a continuation-in-part of application Ser. No. 06/848,341, filed Apr. 4, 1986, now U.S. Pat. Ser. No. 4,741,330, which is a continuation of application Ser. No. 06/496,116, filed May 19, 1983, abandoned, which is a continuation-in-part of application Ser. No. 06/380,043, filed May 20, 1982, now abandoned.

TECHNICAL FILED

This invention relates to an apparatus and method for manipulating and anchoring cartilage and similar fibrous tissue within a joint.

BACKGROUND ART

Conventional medical clamps have certain disadvantages when used for manipulating cartilage or other tissue within a joint during arthroscopic surgery. Primarily, the clamps have a tendency to slip off the cartilage. Additionally, the size of the clamps in relation to the relatively small space within the joint makes it difficult to maneuver other surgical instruments, such as a scalpel or arthroscope, within the confined space of the joint. Such clamps can also interfere with the view of the inside of the joint afforded by the arthroscope. Since the clamps must be introduced into the joint through an incision, they are limited in their range of manipulation by the location of the incision. In order to apply a desired directional traction to the cartilage, it may be necessary to release the clamp from the cartilage, reintroduce the clamp through another incision, and reclamp the cartilage.

It is often necessary to repair torn fibrous tissue, such as a ligament or tendon, or reattach such tissue to bone. While in some instances it is possible to insert two needles into the joint and then thread both of them with a suture to form a loop to reattach torn parts of fibrous tissue, that procedure is undesirable because it is complex and time-consuming. The alternative of more radical arthrotomy is also undesirable because of the increased amount of trauma and resultant increased morbidity encountered in the use of such a procedure.

As is explained in the following summary and description, the present invention provides a relatively compact and easy to use apparatus for manipulating cartilage and other fibrous tissue, and for anchoring the tissue to other tissue or to bone. Some technical references that may be of general interest are as follows: Allen, U.S. Pat. 3,699,969; Shein, U.S. Pat. 3,527,223; Woo, U.S. Pat. 3,943,932; Almen, U.S. Pat. 3,500,820; Johnson et al., U.S. Pat. 3,871,368; and Smith, U.S. Pat. 4,243,037. None of these references discloses a method or apparatus suitable for manipulating fibrous tissue during arthroscopic surgery, or for effectively reattaching fibrous tissue to bone or to other fibrous tissue.

Disclosure of Invention

The aforementioned problems associated with use of conventional medical clamps for manipulating tissue are over-

come by the present invention, which provides an apparatus and an associated method for manipulating and anchoring tissue during arthroscopic surgery. The apparatus provides adequate fixation of the tissue during such surgery and minimally interferes with the use of other instruments within the joint.

The apparatus particularly comprises an elongated anchor member having a suture attached proximate the midpoint of its length. The anchor member is inserted through the tissue with the suture extending therefrom to provide a mechanism for manipulating the tissue within the joint. The end faces of the anchor member may be slanted to facilitate movement of the anchor member through the tissue.

The preferred means of inserting the anchor member includes a hollow needle having a sharp tip and an open butt. A hollow tube of equal or greater length than the needle slides within the needle. A limiting mechanism is provided at the butt of the needle and at the corresponding portion of the hollow tube to selectively position the tube within the needle so that the tube does not extend outwardly beyond the tip of the needle.

The anchor member is located within the tip of the hollow needle in either a deformed U shape, or in its normal, substantially straight shape. The suture extends from the anchor member through the bore of the tube.

A removable shield fits over the tip of the needle to prevent the sharp tip from cutting the suture or the anchor member during the process of inserting the anchor member into the hollow needle.

With the anchor member located within the tip of the needle, the needle tip is inserted into a joint during a surgical procedure. The needle tip pierces the tissue to be anchored and passes substantially through the tissue. The limiting mechanism is manipulated so that the tube may be pushed forward to the tip of the needle, thereby expelling the anchor member from the tip of the needle into or behind the piece of tissue to be anchored. As the anchor member is expelled from the tip of the needle it assumes an orientation generally perpendicular to the length of the suture. The needle and tube are then removed from the joint, leaving the suture extending through the tissue and out of the joint. The tissue is manipulated by the application of tension on the suture.

If it is desirable to push the tissue, the suture may be rethreaded or left threaded in the tube and the tissue may then be securely held between the tube and the anchor member by applying tension to the suture. If it is desirable to control the tissue from a different angle, or through a different incision, a hook-ended instrument may be passed through another incision to hook the suture and pull the tissue. It will be apparent that moving the tissue in this manner is possible without detaching the anchor member from the tissue. If necessary, the tissue may be removed from the joint by tension on the suture once the tissue has been surgically freed from the joint.

It is often desirable to permanently reattach to bone fibrous tissue, such as tendons or ligaments. An alternative embodiment of a tissue anchoring apparatus is provided for that purpose. More particularly, the apparatus of this embodiment includes a deformable anchor member that has a base and at least two legs. Each leg is attached to the base and extends therefrom to terminate in an outer end. A suture is attached to the base of the anchor member. The anchor member is formed of resilient material for urging the anchor member into a relaxed position wherein the ends of the legs are spaced apart a maximum distance. The anchor member is deformable into a deformed position wherein the ends of the legs are spaced apart a minimum distance that is less than the maximum distance.

While in the deformed position, the anchor member is insertable into a hole that is drilled into the bone at the location the tissue is to be attached to the bone. The hole has a diameter that is less than the maximum distance between the ends of the anchor member legs. Consequently, upon insertion of the anchor member into the hole, the ends of the anchor member legs bear, upon the bone within the hole, and the suture extends from the hole. Whenever tension is applied to the suture, the ends of the legs dig into the bone and resist removal of the anchor member from the hole.

With the anchor member anchored in the hole, the suture is available for securing the tissue to the bone. One way of using the suture to secure the tissue to the bone is to attach a retainer to the suture for pressing the tissue against the bone. The retainer includes resilient suture-engaging edges and corners, and is slidable along the suture in one direction, but grips the suture to resist sliding in the opposite direction. The retainer thereby holds tissue against the bone during healing so that the tissue will properly reattach to the bone.

To avoid prolonged irritation of surrounding tissues, the anchor member, suture, and retainer of the present invention may be made of material that is gradually absorbable by the body.

The foregoing and other features of the invention will be more readily understood upon consideration of the following detailed description of the invention, taken in conjunction with the accompanying drawings.

BRIEF DESCRIPTION OF THE DRAWINGS

FIG. 1 is an elevational view of an apparatus for manipulating and anchoring tissue according to the present invention, with a portion of the apparatus sectionally cut away.

FIG. 2 is a sectional elevational view of the apparatus shown in FIG. 1, illustrating the manner of deformably lodging an anchor member within the tip of a hollow needle.

FIG. 3 is a fragmentary, sectional elevational view of the apparatus of FIG. 1, showing the apparatus piercing cartilage.

FIG. 4 is a fragmentary, sectional elevational view of the apparatus of FIG. 1, illustrating the manner of expelling the anchor member between cartilage and bone.

FIG. 5 is a sectional elevational view of the apparatus of FIG. 1, showing cartilage secured by the anchor member and suture components of the apparatus.

FIG. 6 is an enlarged perspective view of the anchor member and suture, showing the normal and deformed configuration of the anchor member.

FIG. 7 is a foreshortened perspective view of a hook-ended instrument usable with the apparatus of FIG. 1.

FIG. 8 is a sectional elevational view of an apparatus for manipulating and anchoring tissue, illustrating an alternative manner of lodging the anchor member within the tip of the needle.

FIG. 9 is a sectional elevational view of the apparatus shown in FIG. 8, illustrating expulsion of the anchor member from the tip of the needle.

FIG. 10 is a perspective view of the inner surface and an edge of a retainer used in association with the suture and the anchor member for securing tissue to bone or to other tissue.

FIG. 11 is a perspective view of the outer surface and an edge of the retainer shown in FIG. 10.

FIG. 12 is a perspective view of an alternative retainer.

FIG. 13 illustrates a portion of a joint in which the anchor member, suture, and retainer are used to connect and retain a piece of cartilage in position against another piece of cartilage from which it had been torn.

FIG. 14 is a sectional view taken along line 14-14 of FIG. 13.

FIG. 15 is a side elevational view, partly in section, of an anchor member and suture that can be anchored to a bone.

FIG. 16 is a sectional elevational view of the anchor member and suture of FIG. 15, positioned within the preferred mechanism for inserting the anchor member into a hole in a bone.

FIG. 17 is a sectional elevational view showing the anchor member of FIG. 16 anchored within a hole in a bone and used, in conjunction with the suture and a retainer, to hold tissue against the bone.

FIG. 18 is a sectional elevational view showing an alternative method of using an anchor member and suture to hold tissue against the bone.

FIG. 19 is a side cross-sectional view of an alternative embodiment of an anchor member that has a hole formed therethrough to permit a suture to be looped through it.

FIG. 20 is a cross-sectional view of another alternative embodiment of an anchor member that can be anchored to a bone.

FIG. 21 is a top view of the anchor member of FIG. 20.

Modes for Carrying out the Invention

One preferred embodiment of the present invention, shown assembled in FIGS. 1 and 2, provides a resiliently deformable anchor member 10, which is attached to a suture 12 and adapted to fit deformably within the tip 26 of a hollow needle 14. A hollow tube 16, also adapted to fit within the needle 14, is used to expel the anchor member from the tip 26 of the needle after the needle has pierced a piece of fibrous tissue, such as the cartilage 18, as shown in FIGS. 3 and 4. Once expelled between the cartilage 18 and bone 38, the anchor member resiliently resumes its normal shape, as shown in FIG. 5. The anchor member of the invention might also be used to secure ligament or tendon, as will be described hereinafter, and the term tissue will be broadly used herein to encompass cartilage, tendons, ligaments and similar tissue.

The anchor member 10, shown in perspective view in FIG. 6, is an elongated cylindrical member. The anchor member 10 has end faces 20 and 22, at the respective extremities thereof. The end faces 20 and 22 are slanted relative to the longitudinal axis of the anchor member and preferably lie in respective planes that intersect one another. The suture 12 is attached to the anchor member 10 at a location 24 between the end faces 20 and 22. The suture 12 may be attached to the anchor member 10 during formation of the anchor member.

The anchor member 10 is preferably comprised of a resilient material such as a plastic. As a result, the anchor member is capable of being deformed from its relaxed, straight shape into a U-shape as shown in broken line in FIG. 6. Although the anchor member is shown to have a circular cross-section, other cross-sectional shapes could be utilized without departing from the principles of this invention.

The anchor member 10 is formed with sufficient rigidity to cause it to resist deformation under moderate pressure, but not so rigid as to prohibit the U-shaped deformation when the anchor member is lodged within the needle as shown in FIGS. 2 and 3. The material comprising the anchor member has sufficient elasticity to restore the anchor member substantially to its relaxed, straight configuration shown in FIGS. 1, 4, 5 and 6.

The needle 14 shown in FIGS. 1 and 2 has a hollow cylindrical shape with a sharp-edged open tip 26, an open butt 27, and a bore extending longitudinally therethrough from the tip 26 to the butt 27. The sharp tip 26 is beveled to create a sharp

5

edge at its outer circumference and is thereby adapted to pierce and penetrate tissue. Alternatively, the sharp tip 26 could be beveled to create a sharp edge at its inner circumference.

An annular collar 28, which includes an open keyway 30 formed therein, encircles the butt of the needle. The keyway extends a short distance toward the needle tip through the cylindrical wall of the needle as shown in FIG. 2.

The hollow tube 16, which is at least as long as the needle 14, and has an elongate cylindrical shape with an open tip 17 and an open butt 19, is adapted to slide within the hollow needle. The tube 16 has an interior bore diameter large enough to receive the suture 12 therethrough so that the free end 13 of the suture extends from the open butt 19 of the tube. The tube 16 has an annular flange 32 encircling the butt 19 thereof to prevent the tube, when pushed toward the needle tip 26, from protruding more than a predetermined distance beyond the tip. The tube is preferably such a length that when the flange 32 is positioned immediately adjacent the collar 28, the tip 17 of the tube is proximate the needle tip 26, as shown in FIG. 4.

A limiting mechanism for controlling movement of the tube 16 is provided in the form of a key 34 that is mounted on the outer cylindrical wall of the tube 16. The key 34 is adapted to mate with the keyway 30 associated with the needle 14. The key 34 will prevent, the tip 17 of the tube 16 from moving proximal to the tip 26 of the needle 14 unless the key 34 is aligned with the keyway 30. This alignment is accomplished by rotation of the tube 16 within the needle 14. If the tube 16 is of the aforementioned preferred length, the key 34 should be located close enough to the tip 17 of the tube 16 to permit the anchor member 10 to be fully drawn into the needle tip 26 when the tube is positioned inside the needle with the key and keyway out of alignment, as shown in FIGS. 2 and 3. As will be apparent, the keyway 30 should be of sufficient length to allow the flange 32 to contact the collar 28 when the key 34 is positioned in the keyway 30. It should be recognized that, while the aforescribed key and keyway arrangement is believed to be particularly suitable, other mechanisms for limiting the movement of the tube 16 within the needle 14 could be utilized without departing from the principles of this invention.

As shown in FIGS. 1 and 2, a shield 36 having a generally cylindrical shape with open ends is adapted to fit removably on the sharp needle tip 26. The inner walls of the shield have three distinct sections: an upper section 29, an intermediate section 31, and a lower section 33. The upper section 29 is cylindrical and has an inner diameter substantially equal to the outer diameter of the needle tip 26 so as to permit the shield to be mounted over the tip 26. The intermediate section 31 is cylindrical and has an inner diameter slightly smaller than the outer diameter of the needle tip 26, to shield the anchor member from the sharp edge of the needle tip 26. The lower section 33 has a bell-like flared shape to encourage appropriate deformation of the anchor member 10 as it is drawn into the needle tip 26 as shown in FIG. 2.

Prior to use, the apparatus is first assembled as shown in FIGS. 1 and 2, the shield 36 being mounted upon the tip 26 prior to the suture 12 being threaded through the tube 16 so that the free end 13 protrudes out the butt end 19 of the tube. Tension on the free end 13 of the suture 12 will pull the anchor member 10 into the needle tip 26 as shown in FIG. 2, the inner surface of the bell-shaped lower section 31 of the shield guiding the anchor member into the appropriate U-shape, the anchor member being protected from the sharp tip by the shield 36.

6

The tube 16 is axially positioned within the needle with the key 34 abutting the collar 28 so that there is appropriate space for the anchor member to lodge deformably within the needle tip 26. Positioning the tube 16 within the needle as shown in FIGS. 1 and 2 is not necessary prior to introducing the free end 13 of the suture 12 into and through the bore of the needle 14, but having the tube so positioned when the anchor member 10 is drawn into the tip 26 is helpful to ensure that the anchor member 10 is not positioned an unnecessary distance from the needle tip 26. Once the anchor member 10 is deformably lodged in the tip 26, the shield 36 may be removed.

The assembled apparatus may then be introduced into the joint of a patient, either through an incision or by using the needle tip 26 to pierce the skin and surrounding tissue. The tip 26 of the needle 14 is thereafter used to pierce the cartilage 18 which is to be manipulated or anchored, as shown in FIG. 3.

Once the tip 26 has pierced the cartilage 18, the tube 16 may be axially rotated within the needle 14 so that the key 34 aligns with the keyway 30. The tube 16 may then be pushed toward the tip 26 of the needle 14, the key 34 entering the keyway 30, and the tip 17 of the tube 16 expelling the anchor member 10 from the needle tip 26 as shown in FIG. 4. As the anchor member 10 is pushed from the needle tip 26, it resumes its normal elongated shape. Where the cartilage 18 is very near bone 38, the slanted end faces 20, 22 of the anchor member facilitate movement of the longitudinal extremities of the anchor member through the space 40 between the bone 38 and cartilage 18.

Once the anchor member 10 has generally resumed its normal elongate shape behind the cartilage 18, the needle 14 and the tube 16 may be withdrawn from the joint, allowing the cartilage 18 to partially collapse around the anchor member 10 and suture 12 as shown in FIG. 5. The suture 12 is now anchored to the cartilage 18, and the cartilage may be securely held and manipulated by tension on the suture 12 to facilitate further surgical procedures on and around the cartilage.

The relatively small size of the suture 12 allows virtually unobstructed vision of the interior of the joint through an arthroscope, and also permits the insertion of other surgical instruments, such as an arthroscope or scalpel, through the same incision as the suture. Due to the flexibility of the suture 12, tension may be applied from many directions as dictated by the needs of the surgical process. Further control of the cartilage 18 is available by rethreading the suture 12 through the tube 16 and applying tension to the suture, thereby effectively clamping the cartilage 18 between the anchor member 10 and the tip 17 of the tube 16, and allowing the cartilage to be pushed, rather than pulled, into a desired position.

A hook-ended instrument 42, shown in FIG. 7, may be used to achieve even greater maneuverability of the anchored cartilage 18 by introducing the instrument 42 into the joint through a separate incision, capturing the suture 12 in the hooked end of the instrument, and drawing the suture 12 out of the joint through such other incision. The cartilage may then be manipulated and controlled in the manner described above, through a different incision, without detaching the anchor member 10 from the anchored cartilage 18.

If necessary, the anchored cartilage 18 may be surgically freed, and removed from the joint by tension on the suture 12.

Referring now to FIGS. 8 and 9, an anchor member 50, which is similar to the anchor member 10 described above, has fixedly attached thereto a suture 52. The anchor member 50 is held within the tip 53 of a hollow needle 54, ahead of the tip 56 of a hollow tube 55. The edge of the hollow needle 54 at the tip 53 is formed in a plane that is slanted relative to the longitudinal axis of the needle, thereby to form a sharp lead-

ing edge 51 for piercing tissue. The free end 57 of the suture 52 extends from the hollow tube 55.

As shown in FIGS. 8 and 9, the anchor member 50 may be used in essentially the same fashion as is the anchor member 10, with the hollow needle 54 piercing a piece of fibrous tissue, such as cartilage 60. The anchor member 50 is expelled from the tip 53 of the hollow needle 54 as the hollow tube 55 is slid toward the tip 53 of the hollow needle 54. The anchor member 50 thereafter assumes a position between the cartilage 60 and a bone 62, where it extends generally perpendicular to the suture 52. The slanted end faces 64, 65 of the anchor member 50 assist in directing the anchor member 50 to this position. Once the anchor member 50 has been expelled from the needle 54, the suture 52 is pulled outwardly to move the anchor member 50 to the position shown in broken line in FIG. 9, where it extends laterally along the lower surface of the cartilage 60.

It is noteworthy that the anchor member 50 depicted in FIGS. 8 and 9 may be formed of substantially rigid material. A rigid anchor member can be inserted into the space between the cartilage and bone by moving the needle 54 so that it is inclined to the bone surface and then expelling the anchor member from the needle.

A rigid anchor member may be lodged within cartilage or other tissue (i.e., as opposed to being inserted between cartilage and bone) by expelling the anchor member substantially straight into the tissue and pulling on the suture. Because the suture is attached between the ends of the anchor member, tension on the suture tends to rotate the anchor member into a position substantially perpendicular to the suture, thereby causing the anchor member to become firmly lodged within the tissue. In this regard, rotational movement of the anchor member 50 into a position substantially perpendicular to the suture 52 most readily occurs when the end face 65 that last enters the tissue is slanted so that a force applied perpendicular to that surface (that force being a component of the reaction force of the tissue against the surface 65 as tension is applied to the suture of the expelled anchor member) tends to move that face 65 of the anchor member 50 away from the suture 52. This preferred slanting of the end face 65 is shown in FIGS. 8 and 9.

Referring now to FIGS. 10-14, retainer devices 68 and 69, each having a pair of generally parallel surfaces, are made of resilient material and have slits 70 and 72, respectively, which intersect near the central points of the parallel surfaces, defining pointed corner flaps 71 and 73, respectively. The retainers 68 and 69 are preferably circular because the circular shape may reduce the possibility of irritation of surrounding tissue. It will be understood, however, that this shape is a matter of choice and that other shapes would also be acceptable.

Raised points 74 are provided on the inner surface of the retainer 68 to bear against tissue, and to assist in immobilizing the tissue while the anchor member is in use. In many instances, however, the raised points 74 will not be required and a flat inner surface will suffice. The following discussion of retainer use is directed to the anchor member 50 of FIG. 8; however, it is understood that the discussion applies to all embodiments of the anchor member described herein.

The retainer 68 (or retainer 69) may be used in conjunction with the anchor member 50 by inserting the free end 57 of the suture through the retainer at the intersection of the slits 70 after the hollow needle and hollow tube have been withdrawn from around the suture. When the suture 52 is inserted through the retainer 68, the flaps 71 that are defined between adjacent slits 70 are resiliently deformed toward the direction of movement of the suture therethrough. Thereafter, the flaps wedge against the suture 52 and resist withdrawal of the

suture through the slits. By applying tension to the suture 52 (see FIGS. 13 and 14) and urging the retainer 68 along the suture to the surface of cartilage 76 from which the suture extends, the retainer may be used to maintain tension in the suture, thereby holding a loose piece of cartilage 76 against the stable piece of cartilage 78 from which the loose piece of cartilage 76 had been torn or fractured.

The anchor member 50, suture 52, and retainer 68 may be left permanently in the joint to retain the torn cartilage 76 in its proper location against the stable cartilage 78, with the retainer 68 resting against the outside of the stable cartilage 78, between the surface of the stable cartilage 78 and muscle tissue 79 adjacent thereto.

It is noteworthy that in many instances the needle 54 may be inserted into a joint from opposing directions. For example, the anchor member 50 was deposited in the position shown in FIGS. 13 and 14 by a needle that penetrated the muscle tissue 79. The needle could have been inserted from the opposing side of the joint (and not through muscle tissue 79) to deposit the anchor member 50 in the position occupied by the retainer 68 in FIGS. 13 and 14. Accordingly, the positions of the anchor member 50 and the retainer 68 would be reversed from those shown in FIGS. 13 and 14, but the loose cartilage 76 would still be held against the secure cartilage 78. One reason for inserting the needle from the opposing side of the joint, as just explained, would be to avoid damaging any nerves or blood vessels that are present in the region of the muscle tissue 79.

To prevent prolonged irritation of the surrounding tissue by the presence of the anchor member 50 and retainer 68, it is particularly desirable to form the anchor member and retainer of material that can be gradually absorbed by the body of the patient as healing occurs. Resilient, synthetic materials that are gradually absorbable by the body are known for use in sutures and are desirable as materials for the anchor member and retainers of the present invention. One such material is an absorbable polymer known as poly-dioxanone (PDS), which is available from Ethicon, Inc., of Summerville, New Jersey.

Referring now to FIGS. 15-17, an anchor member 80 is particularly adapted for use in anchoring a suture 82 to bone 96 so that the suture 82 may be used to reattach tissue 98 to the bone. The anchor member 80 is generally bullet-shaped having a rounded convex base 84 with two attached legs 86 extending from the base. The outer ends 85 of the legs are tapered and terminate in sharp outer edges 87. The anchor member 80 is formed of resilient material, and whenever the anchor member is in its relaxed state (FIG. 15), the legs 86 diverge outwardly so that the outer edges 87 of the legs are spaced apart a maximum distance D. One end of a suture 82 is embedded within, or otherwise attached to, the base 84 of the anchor member 80. Suture 82 extends outwardly from the base 84 between the legs 86.

Preferably, the outer surface of the anchor member 80 carries a plurality of barbs 88. The barbs 88 point outwardly, and away from the rounded convex base 84. As a result, the exposed sharp point of each barb 88 is directed generally toward the direction in which the suture 82 extends away from the base 84 of the anchor member 80.

As shown in FIG. 16, the anchor member 80 is inserted within the tip 93 of a hollow needle 90 ahead of the tip 91 of a tube 92 that is used to expel the anchor member 80 from the needle. The suture 82 extends through the bore of the tube 92.

The anchor member 80 and the bore of the needle 90 are sized so that the anchor member is in a deformed position whenever it is lodged within the tip 93 of the needle. In the deformed position, the legs 86 of the anchor member are pressed together with the outer edges 87 of the legs being

spaced apart a minimum distance d corresponding to the needle bore diameter. This distance d is less than the maximum distance D between the outer edges **87** as measured when the anchor member is in the relaxed position (FIG. **15**).

As noted, the anchor member **80** is formed of resilient material. Consequently, whenever the anchor member **80** is expelled from the needle **90**, the intrinsic resilience of the anchor member urges it into the relaxed position. As will now be explained, the tendency of the anchor member **80** to move from the deformed into the relaxed position provides a simple mechanism for anchoring the anchor member **80** in bone so that, in conjunction with the attached suture, there is provided a means for reattaching tissue to the bone to promote healing.

More particularly, with reference to FIG. **17**, a hole **100** is drilled into the bone **96** in the region where the tissue **98** is to be reattached to the bone. The hole diameter is less than the maximum distance D between the outer edges **87** of the anchor member, but greater than or equal to the bore diameter of the needle **90**. With the anchor member **80** within the tip **93** of the needle **90**, the tissue **98** is pierced by the needle in a manner as described earlier. The tip **93** of the needle is forced through the tissue **98** and then aligned with the hole **100**. Next, the anchor member **80** is expelled from the needle into the hole **100** by sliding the tube **92** toward the tip **93** of the needle **90** as described earlier with respect to FIGS. **3-5**.

Once expelled from the needle **90** into the hole **100**, the resilience of the anchor member **80** urges the outer edges **87** of the legs **86** to bear upon the bone within the hole **100**. With the outer edges **87** of the legs bearing upon the bone, any tension applied to the suture **82** causes the sharp edges **87** to dig into the bone to secure the anchor member within the hole. The barbs **88** also dig into the bone to supplement the anchoring effect of the legs **86**.

Preferably, the anchor member **80** is sized so that when it is positioned within the hole **100**, the outer edges **87** of the legs **86** are beneath a relatively dense bone layer **97** that is located at the surface of the bone **96**, and is known as the cortical layer **97**. As a result, tension in the suture (in conjunction with the intrinsic resilient force of the anchor member **80** that forces the leg edges **87** apart) tends to lodge the edges **87** of the anchor member beneath the cortical layer **97**, rendering the anchor member substantially irremovable from the hole **100**.

As shown in FIG. **17**, a retainer **68**, as described earlier, may be employed with the suture **82** to secure the tissue **98** to the bone **96**.

FIG. **18** illustrates another technique for securing tissue **99** to the bone **96**, wherein two anchor members **80** are anchored in holes **101**, **103**, and the free ends of the sutures **82** are tied together over the tissue.

It is noted that it may not be necessary to first pierce the tissue **99** before depositing the anchor member **80** into the hole **101**, **103**. For instance, the anchor member **80** may be deposited within the hole **101**, **103** in the manner described above, and the free end of the suture **82** may be threaded through a conventional surgical needle that is used to pierce the tissue. The surgical needle is then removed and the free ends of the sutures **82** are secured as described above.

FIG. **19** depicts an alternative embodiment of an anchor member **110** suitable for anchoring in bone. The anchor member **110** is substantially similar to the anchor member **80** described earlier, except that it includes a continuous passage **112** formed therein to pass into one leg **114**, through the base **116**, and out the other leg **115**. The suture **118** is threaded through the hole passage **112** so that two suture segments **120** extend from the anchor member. This configuration of the anchor member **110** allows the user to select any type of suture for use with the anchor member **110**, depending upon

the particular surgical needs. Further, having two suture segments **120** available for securing the tissue to the bone is often desirable. For example, whenever an odd number of anchor members **116** is used, the resulting even number of available suture segments **120** permits each segment of one anchor member to be tied to a corresponding segment of an adjacent anchor member, without the need for tying more than two suture segments together.

FIGS. **20** and **21** illustrate a side sectional view and top view, respectively, of another alternative embodiment of an anchor member **130** formed in accordance with this invention. This embodiment is a generally cup-shaped piece of resilient material, such as plastic, having a base **132** with four legs **134** extending upwardly therefrom. The sharp outer edge **136** of each leg is spaced apart from an opposing edge **136** by a maximum distance D whenever the anchor member is in the relaxed position as shown in FIG. **20**. As noted earlier, distance D is greater than the diameter of the hole into which the anchor member **130** is deposited. Preferably, two holes **138** are formed in the base **132** of the anchor member **130**. A suture **140** is threaded through the holes **138**.

The anchor member **130** is deposited within a hole in a bone in a manner similar to that explained with respect to the apparatus of FIG. **16**. Specifically, the anchor member **130** is positioned within the tip of a hollow needle (not shown) where it assumes a deformed position. In the deformed position, the outer edge **136** of each leg is held near the outer edge **136** of the opposing leg a distance d that is less than the "relaxed" distance D and corresponds to the diameter of the needle bore in which the anchor member is lodged. When the anchor member **130** is expelled from the needle and deposited within the hole in the bone, the intrinsic resilience of the anchor member **130** forces the outer edges **136** against the bone, thereby anchoring the anchor member within the hole. The suture **140** is thereafter available to secure tissue against the bone as discussed above.

The anchor members **80**, **110**, **130** just described may be formed of material that is absorbable by the body. Alternatively, the anchor members may be formed of non-absorbable material (e.g., stainless steel of suitable resilience) that remains in the bone indefinitely.

The terms and expressions that have been employed in the foregoing specification are used herein as terms of description and not of limitation, and there is no intention, in the use of such terms and expressions, of excluding equivalents of the features shown and described or portions thereof, it being recognized that the scope of the invention is defined and limited only by the claims that follow.

I claim:

1. An apparatus for insertion into and through tissue to provide a mechanism for manipulating and anchoring tissue within a patient, the apparatus comprising:

an elongated anchor member having opposite ends that are tapered to be insertable into and through the tissue to be manipulated, the member being shaped to normally assume a substantially straight configuration; and
a suture irremovably attached to the anchor member between the opposite ends of the anchor member, the suture having an end free for manipulating the tissue into which the anchor member is inserted, the suture being flaccid in the vicinity of the anchor member so that the suture and anchor member do not assume a predetermined relative orientation.

2. The apparatus of claim **1** wherein the suture is a flexible, non-stiffened member in the vicinity of the anchor member.

3. The apparatus of claim **1** wherein the anchor member is resiliently deformable.

11

4. The apparatus of claim 1 wherein the tapered ends of the anchor member define slanted end faces.

5. The apparatus of claim 1 wherein the suture is attached to facilitate substantially perpendicular extension of the suture from the anchor member.

6. The apparatus of claim 1 wherein the suture is attached to the anchor member medially thereof and extends laterally away from said elongated anchor member.

7. The apparatus of claim 1 wherein the anchor member is insertable through the tissue to be manipulated by the suture to a position underneath the tissue and the suture extends therefrom to outside of the tissue.

8. The apparatus of claim 1 wherein the suture and anchor member are configured such that the end of the suture is free for manipulating the anchor member to thereby manipulate the tissue.

9. The apparatus of claim 1 wherein the free end of the suture is a first end and the suture also has a second end, which second end is fixed to the anchor member, and wherein the anchor member is insertable to a manipulation position underneath the tissue that is thereafter to be manipulated, and wherein in the manipulation position, the first end is outside the tissue and the second end is underneath the tissue.

10. The apparatus of claim 1 wherein the suture and anchor member have a manipulation position in which the anchor member is substantially entirely underneath the tissue to be manipulated.

11. The apparatus of claim 1 wherein the anchor member is attached to the suture near the longitudinal midpoint of the anchor member and the suture extends laterally therefrom.

12. *The apparatus of claim 1 further comprising a second anchor member attached to the suture.*

13. *The apparatus of claim 12 wherein the second anchor member is slidingly attached to the suture.*

14. *The apparatus of claim 12 wherein the anchor members have different shapes.*

15. *The apparatus of claim 12 wherein the suture is flaccid in the vicinity of the second anchor member so that the suture and the second anchor member do not assume a predetermined orientation.*

16. *The apparatus of claim 12 wherein the suture is attached to facilitate substantially perpendicular extension of the suture from each anchor member.*

17. *A method, comprising:*

advancing an elongate member to place the elongate member relative to a first body structure of a patient,

placing a flat, circular member relative to a second body structure of the patient with a flat surface of the circular member against the second body structure, the two members being coupled by a flexible member, the circular member being slidable along the flexible member,

applying tension to the flexible member while sliding the circular member along the flexible member, the circular member acting to maintain tension on the flexible member, and

rotating the elongate member from a position substantially parallel to the flexible member during advancement of the elongate member to a position substantially perpendicular to the flexible member.

18. *The method of claim 17 wherein the elongate member is rotated by pulling the flexible member.*

19. *The method of claim 17 wherein the two members are coupled by suture.*

20. *The method of claim 17 wherein the circular member is slid by urging the circular member along the flexible member.*

21. *The method of claim 17 wherein the flexible member is received through an opening in the circular member.*

12

22. *An apparatus for insertion into and through tissue to provide a mechanism for manipulating and anchoring tissue within a patient, the apparatus comprising:*

an elongated anchor member having a substantially cylindrical shape with opposite ends, the member having a first length along a first side and second length that is shorter than the first length along a second side that is opposite to the first side such that ends of the second side are axially spaced from ends of the first side, the member being shaped to normally assume a substantially straight configuration; and

a suture irremovably attached to the anchor member between the opposite ends of the anchor member, the suture having an end free for manipulating the tissue into which the anchor member is inserted, the suture being flaccid in the vicinity of the anchor member so that the suture and anchor member do not assume a predetermined relative orientation.

23. *The apparatus of claim 22 wherein the suture is a flexible, non-stiffened member in the vicinity of the anchor member.*

24. *The apparatus of claim 22 wherein the anchor member is resiliently deformable.*

25. *The apparatus of claim 22 wherein the ends of the anchor member are tapered and define slanted end faces.*

26. *The apparatus of claim 22 wherein the suture is attached to facilitate substantially perpendicular extension of the suture from the anchor member.*

27. *The apparatus of claim 22 wherein the suture is attached to the anchor member medially thereof and extends laterally away from said elongated anchor member.*

28. *The apparatus of claim 22 wherein the anchor member is insertable through the tissue to be manipulated by the suture to a position underneath the tissue and the suture extends therefrom to outside of the tissue.*

29. *The apparatus of claim 22 wherein the suture and anchor member are configured such that the end of the suture is free for manipulating the anchor member to thereby manipulate the tissue.*

30. *The apparatus of claim 22 wherein the free end of the suture is a first end and the suture also has a second end, which second end is fixed to the anchor member, and wherein the anchor member is insertable to a manipulation position underneath the tissue that is thereafter to be manipulated, and wherein in the manipulation position, the first end is outside the tissue and the second end is underneath the tissue.*

31. *The apparatus of claim 22 wherein the suture and anchor member have a manipulation position in which the anchor member is substantially entirely underneath the tissue to be manipulated.*

32. *The apparatus of claim 22 wherein the anchor member is attached to the suture near the longitudinal midpoint of the anchor member and the suture extends laterally therefrom.*

33. *The apparatus of claim 22 further comprising a second anchor member attached to the suture.*

34. *The apparatus of claim 33 wherein the second anchor member is slidingly attached to the suture.*

35. *The apparatus of claim 33 wherein the anchor members have different shapes.*

36. *The apparatus of claim 33 wherein the suture is flaccid in the vicinity of the second anchor member so that the suture and the second anchor member do not assume a predetermined orientation.*

37. *The apparatus of claim 33 wherein the suture is attached to facilitate substantially perpendicular extension of the suture from each anchor member.*

38. *A method, comprising:*

13

advancing a first member into and through tissue in a
 patient, the first member being elongated and shaped to
 normally assume a substantially straight configuration
 and having a suture attached thereto between the oppo-
 site ends of the first member, the suture having an end
 free for manipulating the tissue into which the first mem-
 ber is inserted, the suture being flaccid in the vicinity of
 the first member so that the suture and member do not
 assume a predetermined relative orientation,
 rotating the first member from a position substantially par-
 allel to the suture during advancement of the first mem-
 ber to a position substantially perpendicular to the
 suture,
 placing the first member at a first location within the
 patient,
 placing a second member at a second location within the
 patient, the two members being coupled by the suture,
 the second member being slidable along the suture, and
 applying tension to the free end of the suture, the length of
 the suture between the first and second members being
 shortened with the first and second members tending to
 be drawn together.
 39. The method of claim 38 wherein the tissue comprises
 stable cartilage and torn cartilage, and further comprising:
 advancing the first member such that the suture extends
 from the stable cartilage to the torn cartilage, and
 applying sufficient tension to the suture to retain the torn
 cartilage against the stable cartilage.
 40. The method of claim 38 wherein the free end of the
 suture is a first end and the suture also has a second end,
 which second end is fixed to the first member, and further

14

comprising inserting the first member to a manipulation posi-
 tion underneath the tissue that is thereafter to be manipu-
 lated.
 41. The method of claim 38 wherein the first member is
 rotated by pulling the suture.
 42. The method of claim 38 wherein the second member is
 placed after the first member.
 43. A method, comprising:
 advancing an elongate member to place the elongate mem-
 ber relative to a first body structure of a patient,
 placing a flat member relative to a second body structure of
 the patient, the two members being coupled by a flexible
 member, the flat member being slidable along the flex-
 ible member,
 applying tension to the flexible member while sliding the
 flat member along the flexible member, the flat member
 acting to maintain tension on the flexible member, and
 rotating the elongate member from a position substantially
 parallel to the flexible member during advancement of
 the elongate member to a position substantially perpen-
 dicular to the flexible member.
 44. The method of claim 43 wherein the elongate member is
 rotated by pulling the flexible member.
 45. The method of claim 43 wherein the two members are
 coupled by suture.
 46. The method of claim 43 wherein the flat member is slid
 by urging the flat member along the flexible member.
 47. The method of claim 43 wherein the flexible member is
 received through an opening in the flat member.

* * * * *